

8-CH CAPACITIVE TOUCH SENSOR SPECIFICATIONS

1. REVISION HISTORY

Rev	CONTETNS	DATE
1.0	First Creation	May 3 th , 2008
2.0	Major Updated	Jun 1 th , 2008

CONTENTS

1.	REVISION HISTORY.....	1
2.	FEATURES	3
	2.1 Package	3
	2.2 General Features	3
	2.3 Applications	3
3.	BLOCK DIAGRAM	4
4.	ELECTRICAL CHARACTERISTICS	5
	4.1 Absolute Maximum Ratings	5
	4.2 DC Characteristics	5
5.	PIN DESCRIPTION	6
	5.1. Power Supply Pins	6
	5.2. Sensing OSC Sensitivity Control Pins.....	6
	5.3. System Control Pins	6
	5.4. MPU Interface Pins	6
	5.5. Sensor Input Pins	6
	5.6. Parallel Output Pins.....	6
6.	FUNCTIONAL DESCRIPTION	7
	6.1. MCU Interface	7
	- I ² C- Bus Timing Start/Stop.....	7
	- I ² C- Bus Timing Data.....	7
	- I ² C Write Function.....	7
	- I ² C Read Function.....	7
	6.2. Parameter Data Write/Read Sequence.....	8
	6.3. Sensor Output Data Read Sequence.....	8
	6.4. Output hold time.....	8
	6.5. Self Calibration.....	8
	6.6. Touch Decision.....	9
	6.7. Detection Level Control.....	10
	6.8. Frequency Adjustment for System Clock.....	10
	6.9. Concurrent Touch Handling	11
	6.10. Power Save.....	11
	6.11. Reset	11
	6.12. E ² PROM	11
7.	COMMAND LIST	17
	7.1. System Control Mode	17
	7.2. Soft Reset	17
	7.3. Parallel Interface Selection	17
	7.4. Touch Key Enable.....	17
	7.5. Sleep Mode Selection.....	18
	7.6. Scan Speed for Burst & Sleep Mode, Reference Average Operation Mode.....	18
	7.7. Channel Count Enable.....	18
	7.8. Touch Duration Time	18
	7.9. Global Touch Sensitivity Setting.....	19
	7.10. Local Touch Sensitivity Setting.....	19
8.	CHIP MARKING	20
9.	PACKAGE PIN CONFIGURATION	20
10.	PKG INFORMATION	23

2. FEATURES**2.1 General Feature**

- 8-ch capacitive sensor with auto sensitivity calibration
- Package type : MLF2-24[4*4], ML2-32[5*5], SOP28[300mil]
- I2C serial interface
- Auto-Sleep mode(Burst and Sleep mode)
- Global/Local channel adjustable sensitivity
- Touchoutput Mode for parallel operation
- Touch intensity can be detectable
- Adjustable internal frequency by REXT resistor
- 8ch Open-drain digital output
- Embedded high frequency noise elimination circuit

2.2 Application

- Mobile application(mobile phone / PDA / MP3 player etc)
- Membrane switch replacement
- Sealed control panels, keypads
- Door key-lock matrix application
- Touch screen replacement application

3. BLOCK DIAGRAM

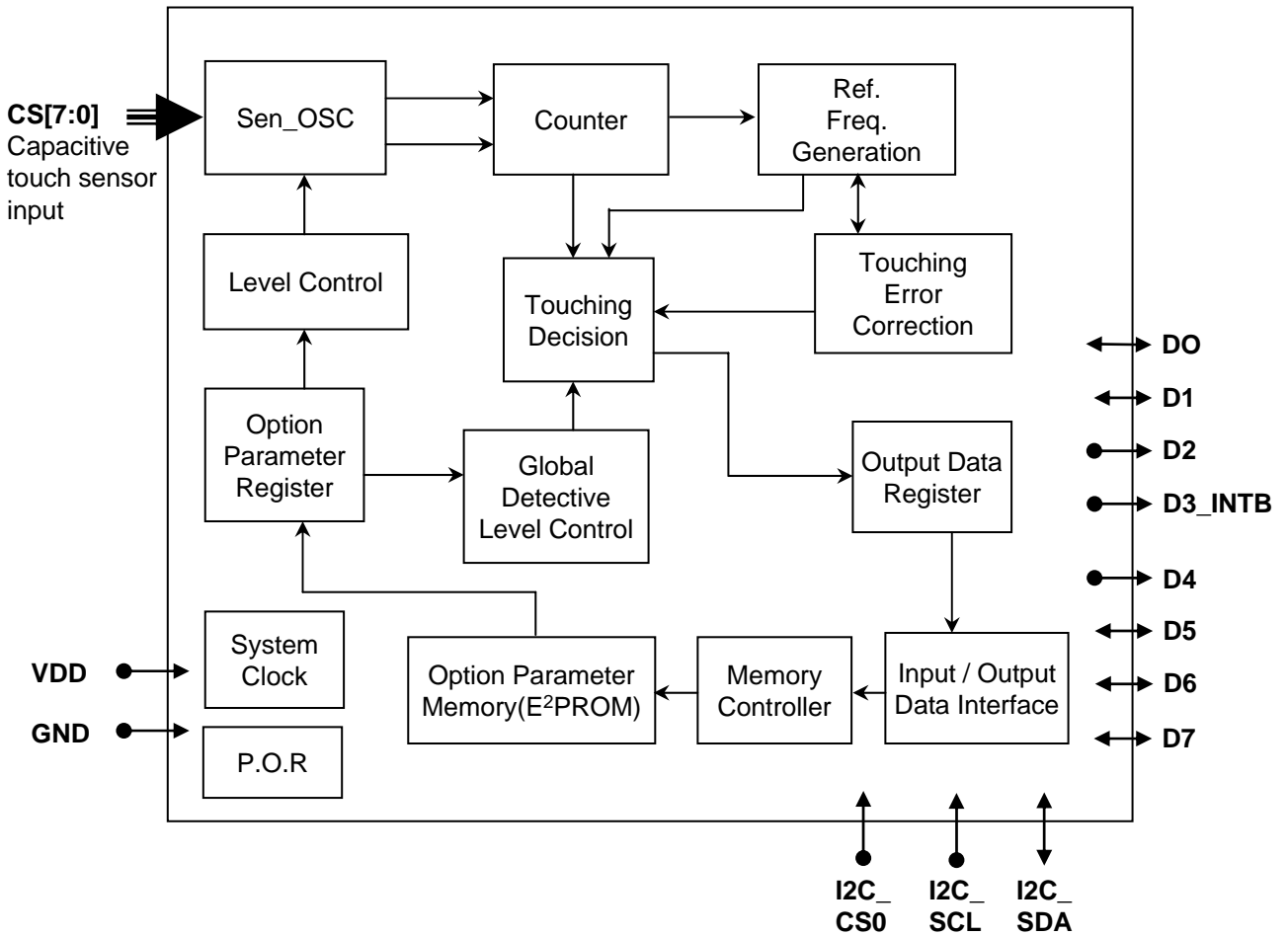

- Common Pin : VDD, GND
- Serial Interface Pin : I2C_SCL, I2C_SDA
- I2C Slave Address : B8h[10111000₂], 54h[01010100₂]
- Reset : Internal POR[VDD Active Voltage : 1.5V]

4. ELECTRICAL CHARACTERISTICS

4.1 Absolute Maximum Ratings

Symbol	ITEM	Value	Unit
V_{DD}	Supply Voltage	3.0 ~ 5.5	V
V_{IN}	Input Voltage Range	- 0.3 ~ $V_{DD}+0.3$	
V_{OUT}	Output Voltage Range	- 0.3 ~ $V_{DD}+0.3$	
V_{PPH}	External VPP for EEPROM	$V_{PPL} + 3.5$	
V_{PPL}	External VPP for EEPROM	12.8 ~ 13.6	
I_{max}	Maximum Current	300uA @ Vdd = 3.3V	A
P_{max}	Maximum Power Dissipation	800mW	W
ESD Stress V	ESD protection	H.B.M 8000	V
T_{OPR}	Operating Temperature Range	- 40 ~ +85	°C
T_{STG}	Storage temperature Range	- 50 ~ +125	°C

4.2. DC Characteristics

($V_{DD}=3.3V$, $T_a = -40 \sim 85^\circ C$)

Symbol	ITEM	Conditions	Related Pins	MIN	TYP	MAX	UNIT
V_{DD}	Operating Voltage	-	V_{DD}	3.0	-	5.5	V
V_{IH}	High Logic Input Level	$I_{out} = 100\mu A$	Logical Input	$0.7 \cdot V_{DD}$	-	V_{DD}	V
V_{IL}	Low Logic Input Level	$I_{out} = 100\mu A$	Logical Input	0	-	$0.3 \cdot V_{DD}$	
V_{OH}	High Logic Output Level	$I_{out} = 10\mu A$	Logical Output	$0.9 \cdot V_{DD}$	-	V_{DD}	
V_{OL}	Low Logic Output Level	$I_{out} = 100\mu A$	Logical Output	0	-	$0.1 \cdot V_{DD}$	
I_{IL}	Input Leakage Current			- 1.0	-	+1.0	
I_{DD}	Current consumption	VDD=3.3V, BF mode VDD=3.3V, Sleep mode			240 100	300 150	uA
I_{SNK}	Output maximum sink current	$V_{DD} = 3.3V$, $R_{bias}=500K$		-	-	4.0	mA
C_{IN}	Input capacitance range			-	4	-	pF
ΔC	Minmum detective cap. diff.	$C_S = 4pF$		-	0.1	-	pF

5. PIN DESCRIPTION

5.1. Power Supply Pins

Signal	Quantity	TYPE	Function
VDD	1	POWER	DV _{DD} /AV _{DD} [Double Bonding]
GND	1	GND	DGND/AGND [Double Bonding]

5.2. System Control Pins

Signal	Quantity	TYPE	Function
SYNC_INT	1	I/O	- Multi-Chip Mode Control Pin - Normal Operation : INTERRUPT Out for touch output status - LDO Power Control

5.3. MPU Interface Pins

Signal	Quantity	TYPE	Function
I2C_CS0	1	I	I ² C Chip Select Pin, Default : Low
I2C_SCL	1	I	I ² C Clock Input Pin
I2C_SDA	1	I/O	I ² C Data In/Output Pin

5.4. Sensor Input Pins

Signal	Quantity	TYPE	Function
CS [7:0]	8	I/O	Analog sensor input

5.5. Parallel Output Pins

Signal	Quantity	TYPE	Function
D[7:0]	8	I/O	- Digital Touch Output Pins[Open Drain I/O Port] - D3_INTB : INTERRUPT Out for touch output status - D7 : IR Input Port

6. FUNCTIONAL DESCRIPTION

6.1 MPU Interface

6.1.1 I²C (Inter-Integrated Chip) – Bus Timing Start/Stop

FIGURE 1-1: BUS TIMING START/STOP

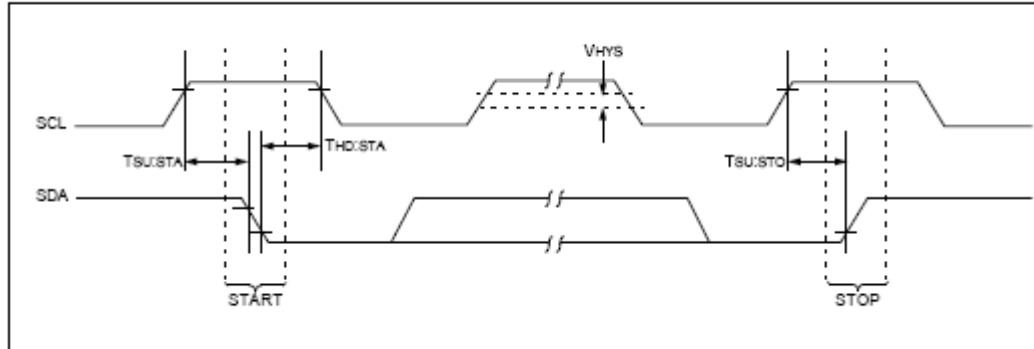

6.1.2 I²C (Inter-Integrated Chip) – Bus Timing Data

FIGURE 1-2: BUS TIMING DATA

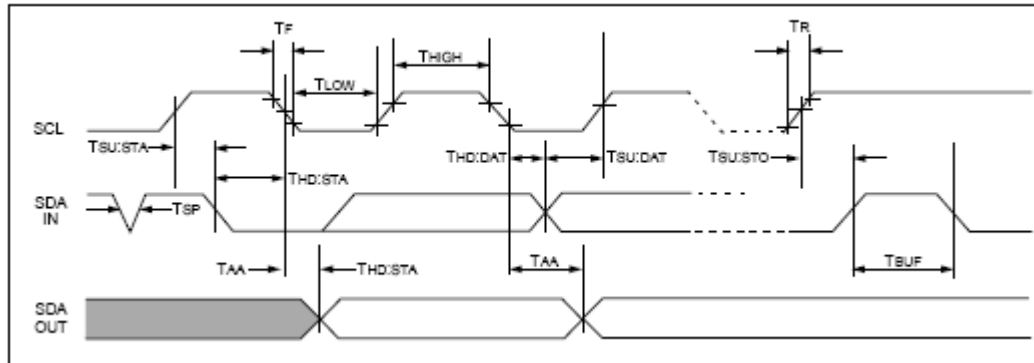

6.1.3 I²C Write Function

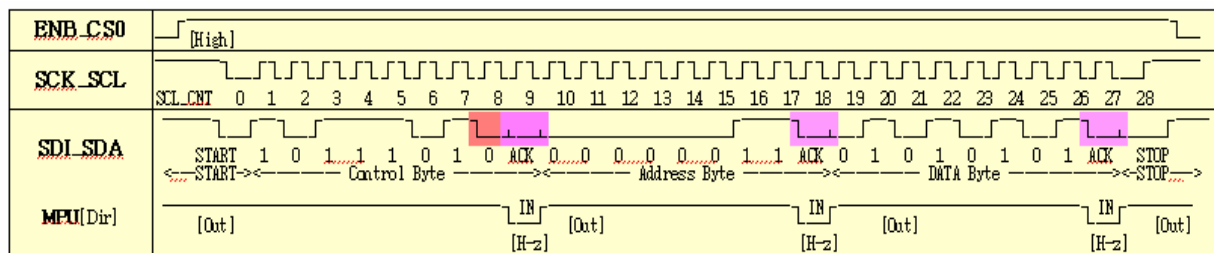

6.1.4 I²C Read Function

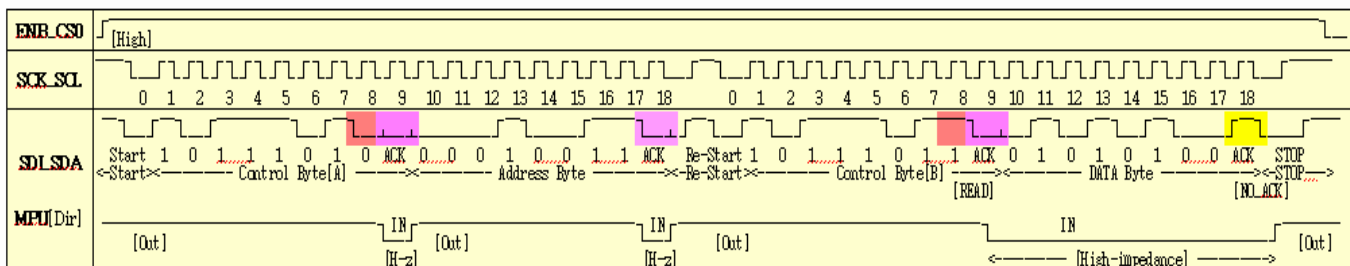

6.2 Parameter Data Write / Read Sequence

Parameter Data Write

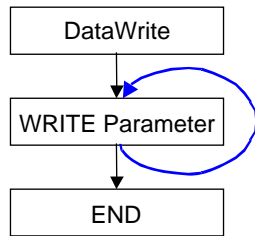

Parameter Data Read

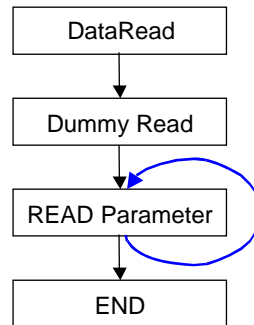

6.3 Sensor Output Data Read Sequence

▣ Touch output data (8bits) are sent to output register. To complete the touch data output, these two registers must be read out sequentially.

D7	D6	D5	D4	D3	D2	D1	D0	← output register
ch7	ch6	ch5	ch4	ch3	ch2	ch1	ch0	

6.4 Output hold time

▣ If it keeps touch-on state, the output holds “1” or touch-on till 10 sec. At 10 sec it resets and do self-calibration.

Output hold time (Thold)	~ 10 sec	@ 10 sec	
Input Touch	Keeps touch-on	Keeps touch-on	
Output	Holds “1”	Do self-calibration	

6.5 Self Calibration

▣ After the system resets, it does self-calibration.

▣ It calibrates base line and threshold automatically for each touch channel.

action	time	Etc.
Self-calibration time (TCAL)	3.9 ms	

6.6 Touch Decision

6.6.1 Basic Touch Decision

- ▣ To decide it is touched or not, reference and threshold are needed.
 If the sensor signal goes below the threshold and stays for required duration time, the touch output goes “1” which means “touched”
- ▣ Sensor signal :
 It is the output of the counter of sensor oscillator. It varies with real time touch sensor capacitance.
- ▣ Reference signal :
 It is the average of the previous N scan counts for each channel. While touch output is “1”(touched), it is not updated. And the status goes to non-touch, it updates.
- ▣ Threshold signal :
 Threshold is for protection against weak noise. It is subtracted by constant number from reference.
 The value is parameterized.
- ▣ Touch on duration :
 Touch on duration time is also for short time noise protection. It is parameterized.

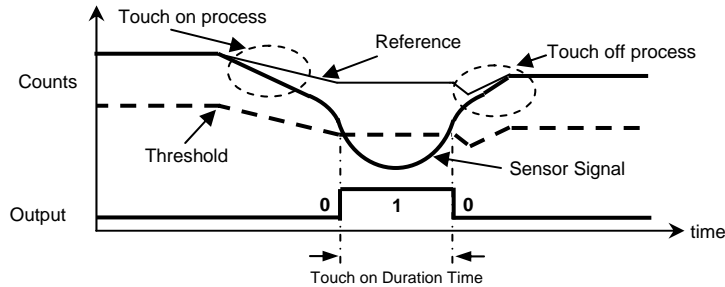

6.7 Detection Level Control

6.7.1 Description

It has 3 ways of controlling the touch detection level (local oscillator control, local touch threshold, global touch threshold).

6.7.2 Local Detection Level Control at Oscillator

- ▮ To adjust the oscillator frequency the *C* and *R* values are selectable using option parameters.
- ▮ When a touch channel is selected by mux, the register values for this channel are set to oscillator.
- ▮ The number of possible oscillator combinations is FSEN0 ~ FSEN7.

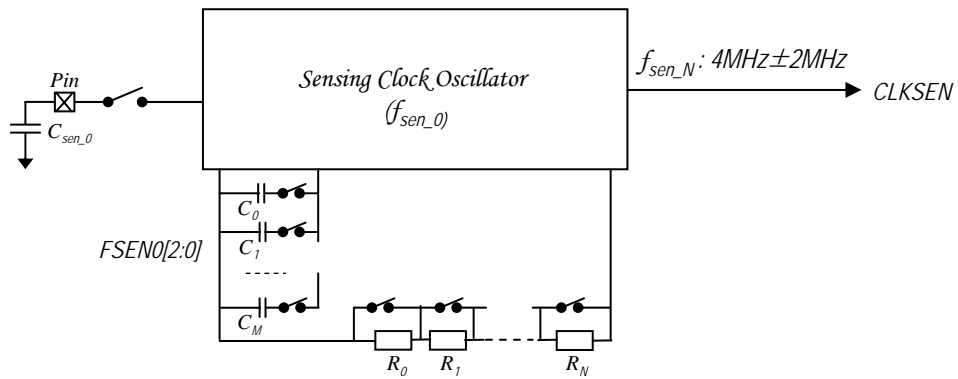

6.7.3 Local Detection Level Control by Touch Threshold of Each Channel.

We can set local threshold factor for each channel.

6.7.4 Global Detection Level Control by Global Touch Threshold

We can set global threshold.

6.8 Frequency Adjustment for System Clock

- ▮ To adjust the system clock frequency the *C* and *R* values are selectable using option parameters.
- ▮ The number of possible oscillator combinations is FSYS[2:0].

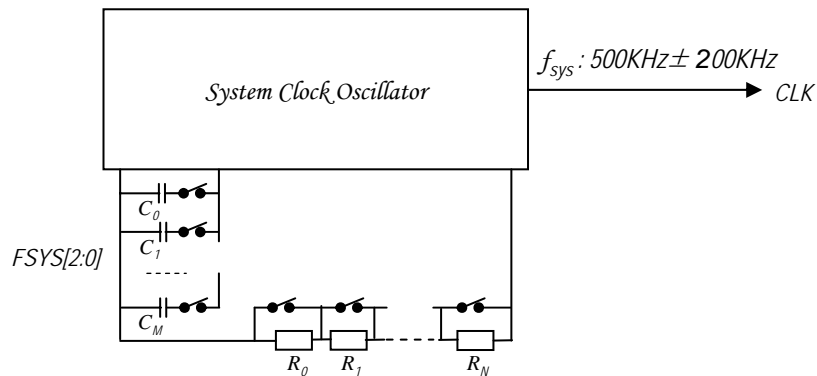

6.9 Concurrent Touch Handling

It has concurrent touch handling function which can distinguish the intended key(s) from concurrently touched keys. There are the following four cases, first touched, last touched, both and deeply touched, according to the option parameter. Please refer 0Ah.

6.10 Power Save

Function	Sleep	Soft Reset	
Command	SLEEPON/OFF	SOFTRES	
Function	- OSC Start/Stop	- Register Clear - SLEEPON	

6.11 Reset

We use the internal reset circuit, which reset the entire chip when the power (VDD) is on [POR], It reset the chip when VDD go over 1,5V automatically. When SOFTRES command is inputted, All Registers are set Default

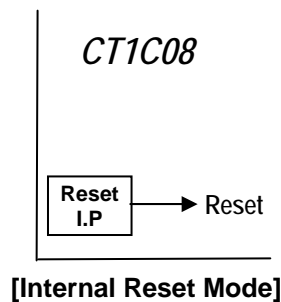

6.12 E²PROM

In power-on mode, when the Register EEP Mode is 'H', the register values in E²PROM are got and set to registers. But when the Register EEP Mode is 'L', the default register values are set to the registers.

In programming mode you can use E²PROM as the register memory or not. When Register EEP Mode is 'H', E²PROM is used. The register values from host are saved in E²PROM and at the same time set to registers. When EEP is 'L', the register values from host are set to registers directly.

6.12.1 Power-up mode

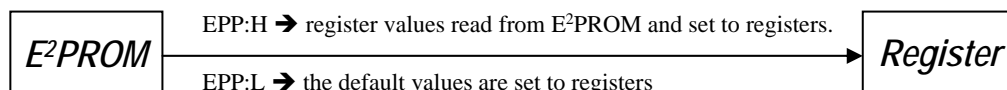

6.12.2 Programming mode

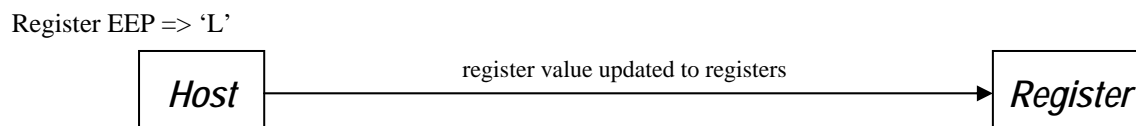
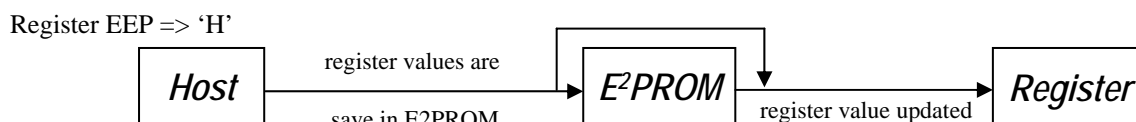

6.12.5 E²PROM Programming Mode

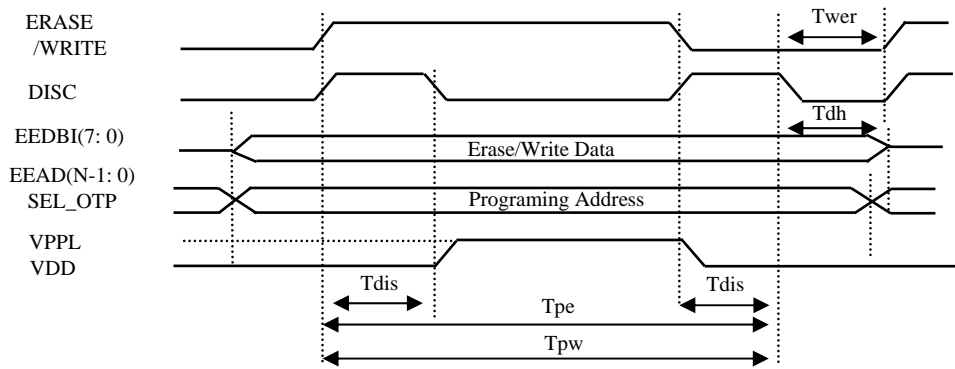

Figure4-2 Programming mode

Parameter	Symbol	Conditions	Min	Typ	Max	Unit
Erase Pulse Width	Tpe		1.4	-	3.6	ms
Write Pulse Width	Tpw		1.4	-	3.6	ms
Write/Erase reset Time	Twer		500	-		ms
Address setup Time	Taddr _s		0	-		ms
Address hole Time	Taddr _h		0	-		ms
Data setup Time	Tds		0	-		ms
Data hole Time	Tdh		0	-		ms
Discharge width	Tdis		3			ms

6.12.6 E²PROM Test Mode (ION Check)

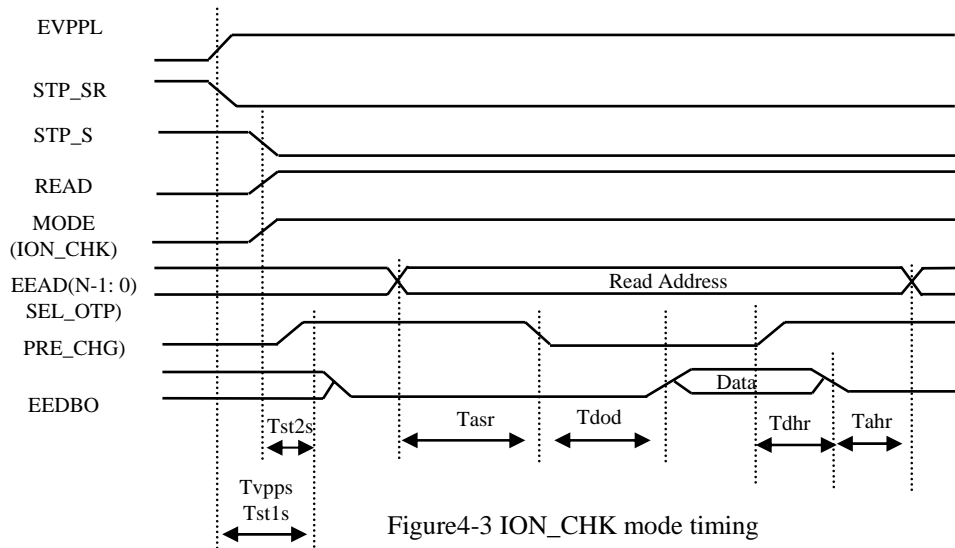

Figure4-3 ION_CHK mode timing

Table4-6 Test mode → ION_CHK

Parameter	Symbol	Conditions	Min	Typ	Max	Unit
STP setup Time	Tst1s		100			ms
	Tst2s		0			ms
Address setup Time	Tahr		0			ms
Address hole Time	Tasr	VDD ≥ 2.7V	75			ms
		VDD ≥ 4.5V	45			ms
Data output delay	Tdod	VDD ≥ 2.7V	1			ms
		VDD ≥ 4.5V	1			ms
Data output hold Time	Tdhr		0			ms
EVPP setup Time	Tvpps		100			ms

. When SEL_OPL=H and EEAD(N-1:3)=00H, OTP Area is selected.

6.12.7 E²PROM Test Mode (CP Test)

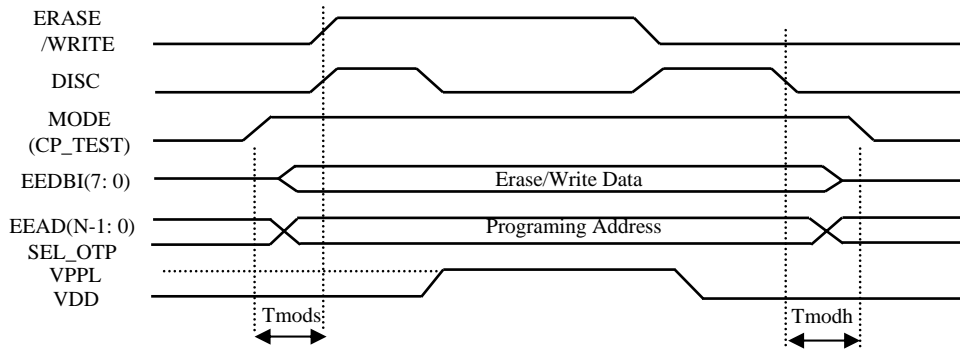

Figure4-4 CP_TEST mode timing

Table4-7 Test mode→CP_TEST

Parameter	Symbol	Conditions	Min	Typ	Max	Unit
CP TEST setup Time	Tmods		0			ms
CP TEST hold Time	Tmodh		0			ms

. Please refer to Table 4-5 for the parameters not included in Table 4-7

6.12.8 E²PROM Test Mode (EXT_VPP)

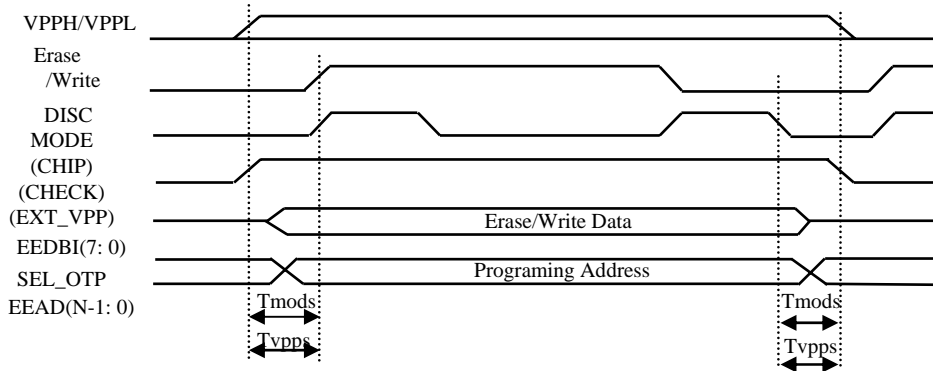

Figure4-5 EXT_VPP (CHIP/CHECKER) mode timing

Table4-8 Test mode→EXT_VPP

Parameter	Symbol	Conditions	Min	Typ	Max	Unit
VPP setup time	tvpps		0			ms
VPP hold time	tvpph		0			ms
EXT_VPP hold time	texh		0			ms
EXT_VPP setup time	texs		0			ms
MODE setup time	tmods		0			ms
MODE hold time	tmodh		0			ms

. Please refer to Table 4-5 for the parameters not included in Table 4-7

. Internal VPP mode is also allowed in chip mode and checker mode.

7. COMMAND LIST

7.1 System Control Mode

INSTRUCTION	Command	Parameter								Parameter Definition	Default	
	A[7:0]	D7	D6	D5	D4	D3	D2	D1	D0			
EEPSET	00h	-	-	-	-	-	-	-	-	D0	EEPROM Reset Update Mode [EEP Pin] D0 : 0 -> Disable D0 : 1 -> Enable	1
		-	-	-	-	-	-	-	-	D1	EEPROM Data Write Mode D1 : 0 -> Disable D1 : 1 -> Enable	1
		-	-	-	-	-	-	D2	-	-	EEPROM Erase/Write Delay Time Setting Mode D2 : 0 -> 2ms D2 : 1 -> 3ms	0
		-	-	-	-	-	D3	-	-	-	D3 : Null	0
		-	-	-	-	D4	-	-	-	-	D4 : 0 -> I2C_SDA PIN Pull Up D4 : 1 -> I2C_SDA PIN Open-drain	0
		-	-	-	D5	-	-	-	-	-	D5 : 1 -> SYNC_INT PIN Pull Up D5 : 0 -> SYNC_INT PIN Open-drain	0

7.2 Soft Reset

INSTRUCTION	Command	Parameter								Parameter Definition	Default
	A[7:0]	D7	D6	D5	D4	D3	D2	D1	D0		
SOFTRES	01h	x	x	x	x	x	x	x	x	Software Reset	-

□ Software reset command

7.3 Parallel Interface Selection

INSTRUCTION	Command	Parameter								Parameter Definition	Default	
	A[7:0]	D7	D6	D5	D4	D3	D2	D1	D0			
ICPSEL	02h	-	-	-	-	-	-	-	-	D0	Parallel interface Output D0 : 0 -> Disable [Test Signal & Interrupt Output] D0 : 1 -> Enable	1
		-	-	-	-	-	-	-	-	D1	Parallel Output Polarity D1 : 0 -> Default Direct [TOUCH -> Low] D1 : 1 -> Reverse Direct [TOUCH -> High]	0
		-	-	-	-	-	-	D2	-	-	Interrupt Output Mode [INTB] D2 : 0 -> Touch On Mode [Low Active] D2 : 1 -> Touch On/Off Edge Mode [Low Active : 6us]	0
		-	-	-	-	-	D3	-	-	-	Interrupt Output Pin Select [INTB] -> Only Single Chip Mode D3 : 0 -> INTB Out Pin [D3_INTB] D3 : 1 -> INTB Out Pin [SYNC_INT]	0
		-	-	-	-	D4	-	-	-	-	LED Output Mode -> LED Data Bit Register : LEDCTRL[07h] D4 : 0 -> LED Output Mode Disable D4 : 1 -> LED Output Mode Enable	0

□ Interrupt Mode & Test Output Mode : D0 -> 0

7.4 Touch Key Enable

INSTRUCTION	Command	Parameter								Parameter Definition	Default	
	A[7:0]	D7	D6	D5	D4	D3	D2	D1	D0			
KEYENABLE0	03h										D0 : 0 -> disabled, 1 -> enabled for 1 st channel	1
											D1 : 0 -> disabled, 1 -> enabled for 2 nd channel	1
											1
											D6 : 0 -> disabled, 1 -> enabled for 6 th channel	1
											D7 : 0 -> disabled, 1 -> enabled for 7 th channel	1

□ Each key can be specified to use or not to use(or enabled / disabled)

□ Disabled key has the same time sharing to enabled key, almost no activity with disabled key.

7.5 Noise Key Setting

INSTRUCTION	Command	Parameter								Parameter Definition	Default
	A[7:0]	D7	D6	D5	D4	D3	D2	D1	D0		
NOISEKEY	04h	D7	D6	D5	D4	D3	D2	D1	D0	D0 : 0 -> disabled, 1 -> enabled for 1 st channel	0
										D1 : 0 -> disabled, 1 -> enabled for 2 nd channel	0
										0
										D6 : 0 -> disabled, 1 -> enabled for 6 th channel	0
										D7 : 0 -> disabled, 1 -> enabled for 7 th channel	0

□ Each key can be specified to use or not to use(or enabled / disabled)

7.6 Sleep Mode Selection

INSTRUCTION	Command	Parameter								Parameter Definition	Default								
	A[7:0]	D7	D6	D5	D4	D3	D2	D1	D0										
SLEEPSEL	05h	-	-	-	-	-	-	-	D0	D0 : 0 -> Stay in Burst Mode	0								
										D0 : 1 -> go to sleep mode 500ms after touched or power-up automatically.									
NSCANBF										-	-	-	D4	-	-	-	-	D1 : 0 -> Sleep Mode Delay Time Select : 1s.	0
																		D1 : 1 -> Sleep Mode Delay Time Select : 2s.	
NSCANSLP	-	-	D5	-	-	-	-	-	D4 : 0 -> 100 Hz [10.0ms/8ch, 1.250ms/1ch]	0									
									D4 : 1 -> 60 Hz [16.6ms/8ch, 2.083ms/1ch]										
										D5 : 0 -> 16 Hz [63ms/8ch, 7.813ms/1ch]	0								
										D5 : 1 -> 8 Hz [125ms/8ch, 15.625ms/1ch]									

□ When any key is touched, it goes to Burst mode.

□ LDO Power Off Mode : Address[0x05]/Data[0x08] -> SYNC_INT Out State : Low
(Register Address 0x02[ICPSEL] -> Data[0b111x xxxx])

7.7 I2C Device ID Setting

INSTRUCTION	Command	Parameter								Parameter Definition	Default
	A[7:0]	D7	D6	D5	D4	D3	D2	D1	D0		
I2CDEVICEID	06h	D7	D6	D5	D4	D3	D2	-	-	D[7:2] -> I2C_Device_ID Setting D[1:0] -> Default : 00, I2C_CS0 -> Low	10111000

□ Default Slave Address : 54h

7.8 LED Control Mode

INSTRUCTION	Command	Parameter								Parameter Definition	Default
	A[7:0]	D7	D6	D5	D4	D3	D2	D1	D0		
LEDCTRL	07h	D7	D6	D5	D4	D3	D2	D1	D0	D0 : 0 -> Port D[0] -> Low[0], D0 : 1 -> Port D[0] -> High[1] D1 : 0 -> Port D[1] -> Low[0], D1 : 1 -> Port D[1] -> High[1] D7 : 0 -> Port D[1] -> Low[0], D7 : 1 -> Port D[7] -> High[1]	00000000

7.10 Channel Count Enable Time

INSTRUCTION	Command	Parameter								Parameter Definition	Default	
	A[7:0]	D7	D6	D5	D4	D3	D2	D1	D0			
T1CHCNT	09h	-	-	-	-	D3	D2	D1	D0	0000 : 150 us	Scan Count Enable Time : (D[3:0] +3) × 50us	
										0001 : 200 us		
										0010 : 250 us		
											
										1001 : 600 us		0
											
										1110 : 850 us		
1111 : 900 us												

7.11 Touch Duration Time

INSTRUCTION	Command	Parameter								Parameter Definition	Default
	A[7:0]	D7	D6	D5	D4	D3	D2	D1	D0		
TCHDR	0Ah [10]	-	-	-	-	-	D2	D1	D0	000 : More Than 0_Period of Burst Fast Mode	
										001 : More Than 1_Period of Burst Fast Mode	
										010 : More Than 2_Period of Burst Fast Mode	O
										
										110 : More Than 6_Period of Burst Fast Mode	
										111 : More Than 7_Period of Burst Fast Mode	
		-	-	D5	D4	-	-	-	-	00 ~ 11 : Touch Output Delay	01

7.12 Reference Update Guard (Threshold) Setting

INSTRUCTION	Command	Parameter								Parameter Definition	Default
	A[7:0]	D7	D6	D5	D4	D3	D2	D1	D0		
REFGUARD	0Bh[11]	D7	D6	D5	D4	D3	D2	D1	D0	00000000 ~ 11111111 : [Threshold] + [0 ~ 255] Count	00100100

- Reference Guard Level : D[4:0] : 0~31 -> Threshold + REFGUARD[4:0] : Reference Update Stop Level
- Chatter Prevent Level : D[7:4] : 0~31 -> Touch On -> Threshold + REFGUARD[7:4] + 3 -> Threshold level up

7.13 Global Touch Sensitivity (Threshold) Setting

INSTRUCTION	Command	Parameter								Parameter Definition	Default
	A[7:0]	D7	D6	D5	D4	D3	D2	D1	D0		
THRGL	0Ch [12]						D2	D1	D0	D[2:0] -> 000 : 0.0 % # of count deviation for 1st global threshold	
										D[2:0] -> 001 : 0.4 % # of count deviation for 1st global threshold	
										D[2:0] -> 010 : 0.8 % # of count deviation for 1st global threshold	O
										D[2:0] -> 011 : 1.5 % # of count deviation for 1st global threshold	
										D[2:0] -> 100 : 3.1 % # of count deviation for 1st global threshold	
				D7	D6	D5	D4	D3	-	-	-

- Global touch sensitivity level setting.
- It controls the sensitivity of all keys simultaneously by digital algorithm.

7.14 Local Touch Sensitivity (Threshold) Setting

INSTRUCTION	Command	Parameter								Parameter Definition	Default
	A[7:0]	D7	D6	D5	D4	D3	D2	D1	D0		
THRLC0	0Dh[13]	-	D6	D5	D4	D3	D2	D1	D0	0000000 ~ 1111111 : [THRGL] + [0 ~ 127] Count	0000010
THRLC1	0Eh[14]	-	D6	D5	D4	D3	D2	D1	D0	0000000 ~ 1111111 : [THRGL] + [0 ~ 127] Count	0000010
THRLC2	0Fh[15]	-	D6	D5	D4	D3	D2	D1	D0	0000000 ~ 1111111 : [THRGL] + [0 ~ 127] Count	0000010
THRLC3	10h[16]	-	D6	D5	D4	D3	D2	D1	D0	0000000 ~ 1111111 : [THRGL] + [0 ~ 127] Count	0000010
THRLC4	11h[17]	-	D6	D5	D4	D3	D2	D1	D0	0000000 ~ 1111111 : [THRGL] + [0 ~ 127] Count	0000010
THRLC5	12h[18]	-	D6	D5	D4	D3	D2	D1	D0	0000000 ~ 1111111 : [THRGL] + [0 ~ 127] Count	0000010
THRLC6	13h[19]	-	D6	D5	D4	D3	D2	D1	D0	0000000 ~ 1111111 : [THRGL] + [0 ~ 127] Count	0000010
THRLC7	14h[20]	-	D6	D5	D4	D3	D2	D1	D0	0000000 ~ 1111111 : [THRGL] + [0 ~ 127] Count	0000010

- Local touch sensitivity level setting for each key.
- It controls the sensitivity of each key individually by changing the threshold.
- 12 parameters must follow command '0Ch consecutively. It overwrite the parameters from 1st channel to 12th channel.
- Parameter definition

D[5:0]	comments
0000000	0 counts for local threshold
0000001	1 counts for local threshold
0000010	2 counts for local threshold
.....
0001000	8 counts for local threshold
.....
1111110	126 counts for local threshold
1111111	127 counts for local threshold

7.15 Reference Count Generation for Touch On Process

INSTRUCTION	Command	Parameter								Parameter Definition	Default
	A[7:0]	D7	D6	D5	D4	D3	D2	D1	D0		
REFGENON	1Ah [26]	-	D6	D5	D4	D3	D2	D1	D0	D[6:0] -> 0000000(0) ~ 1111111(127) : Reference On Count Period	1000000 (64)

□ D[6:0] : the number of period for catching each count data for touch on process.

7.16 Concurrent Touch Handling

INSTRUCTION	Command	Parameter								Parameter Definition	Default
	A[7:0]	D7	D6	D5	D4	D3	D2	D1	D0		
CONCTCH	23h [35]	-	-	-	-	-	-	D1	D0	00 : First touched	
		-	-	-	-	-	-	D1	D0	11 : Basic(all) touched	O

7.17 Read Only Register

INSTRUCTION	Command	Parameter								Parameter Definition	Default
	A[7:0]	D7	D6	D5	D4	D3	D2	D1	D0		
REG_2Ah	2Ah [42]	D7	D6	D5	D4	D3	D2	D1	D0	D[7:0] : Touch Output Data[7:0]	Read
REG_2Bh	2Bh [43]	D7	D6	D5	D4	D3	D2	D1	D0	D[7:0] : Scan Count Data Low Byte[7:0]	Read
REG_2Ch	2Ch [44]	-	-	-	-	D3	D2	D1	D0	D[3:0] : Scan Count Data High Byte[11:8]	Read

8. CHIP MARKING

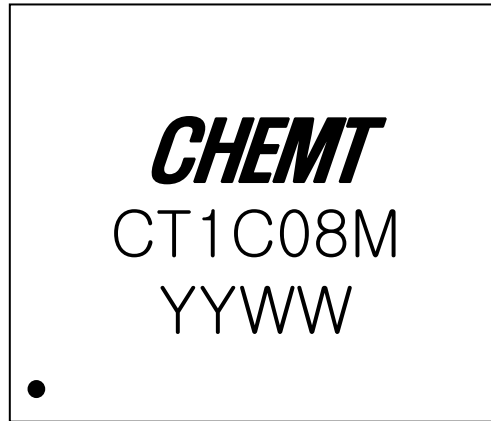

9. PACKAGE PIN CONFIGURATION

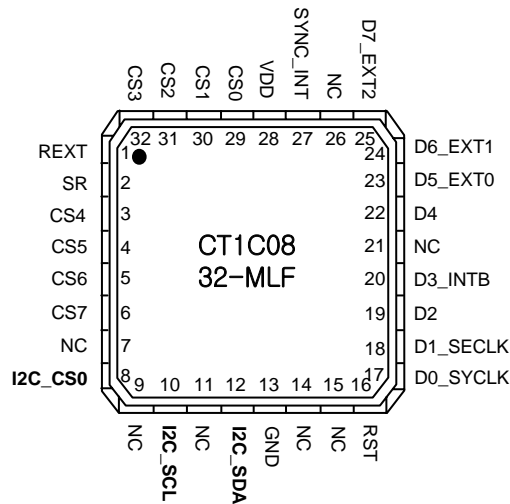

Package Type : MLF2-32[5×5]

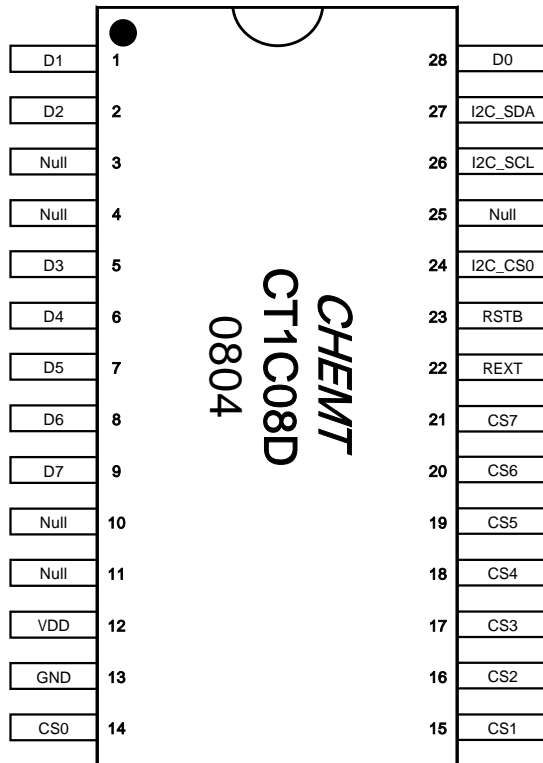

Package Type : SO28P[300mil]

CHIP MARKING

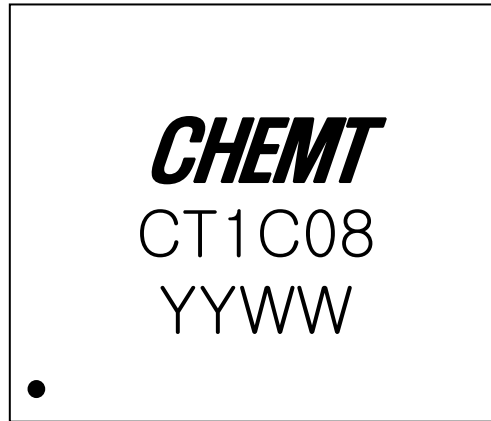

PACKAGE PIN CONFIGURATION

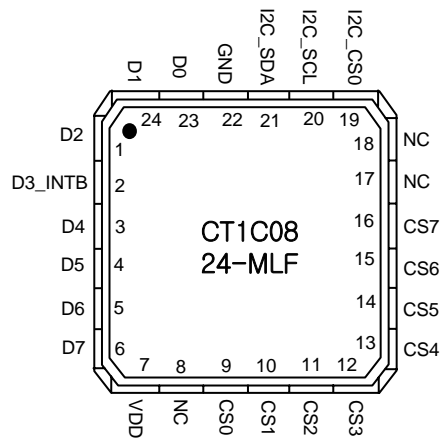

Package Type : MLF2-24[4×4]

PACKAGE INFORMATION

Package Type : MLF2-32[5×5]

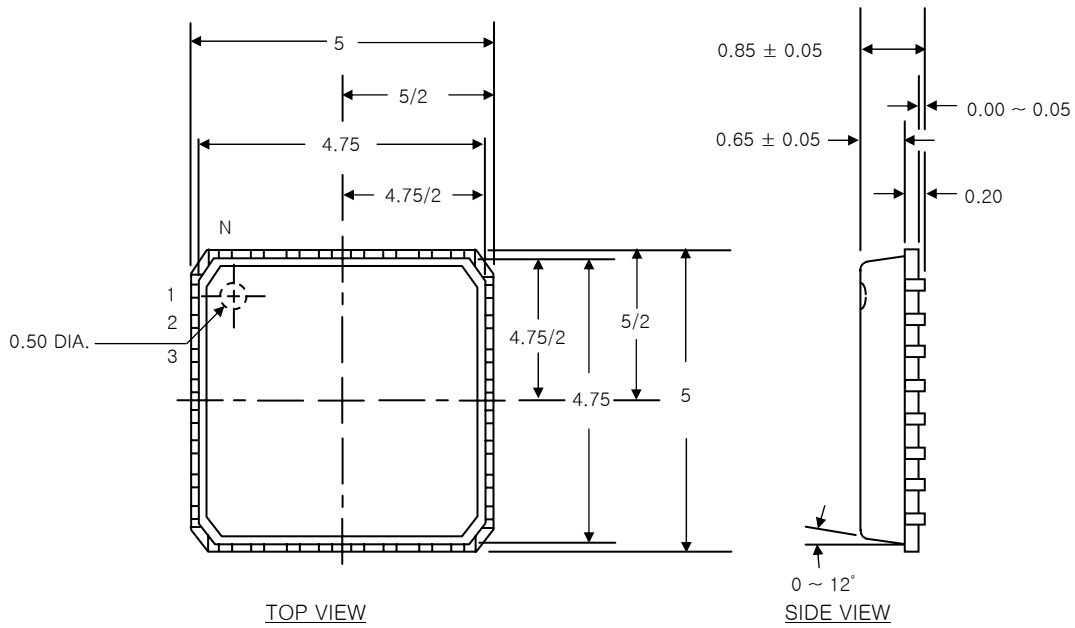

TOP VIEW

SIDE VIEW

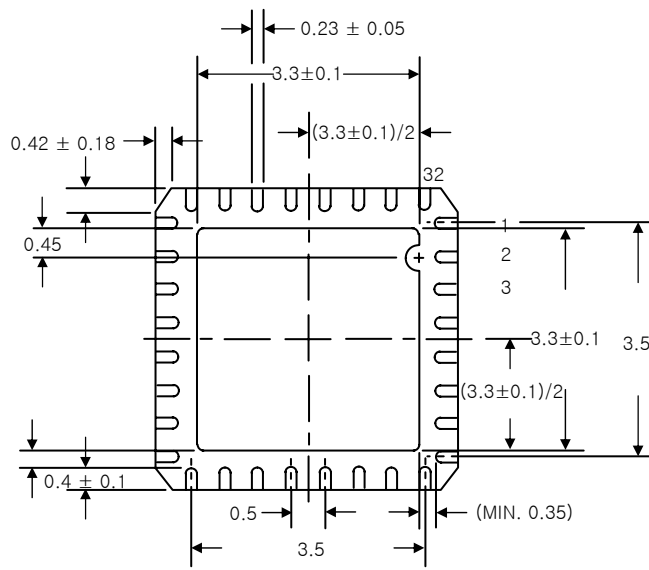

BOTTOM VIEW

PACKAGE INFORMATION

Package Type : MLF2-24[4×4]

