

## 12. ELECTRICAL CHARACTERISTICS

### Absolute maximum ratings over specified temperature range

Supply voltage range, VCC	-0.3 V to 6 V
Input voltage range	-0.3 V to 6 V
Operating free-air temperature range	0°C to 70°C
Storage temperature range	-55°C to 150°C

### Recommended operating conditions

PARAMETERS	MIN	TYP	MAX	UNIT
V <sub>CC</sub> supply voltage	4.5	5	5.5	V
V <sub>SS</sub> supply voltage		0		V
V <sub>IH</sub> high-level input voltage (all digital input pins except RESET)	2			V
V <sub>IL</sub> low-level input voltage (all digital input pins except RESET)			0.8	V
VT+ positive going RESET threshold (at VCC = 5.0 v)		3.35	4.6	V
VT- negative going RESET threshold	1.3	1.9		V
I <sub>OH</sub> high level output current			+4	mA
I <sub>OL</sub> low level output current			-4	mA
Oscillator crystal (100 ppm) Note the 3.8912 MHz crystal frequency is required only if the CT8020 is to operate in codec master mode and generate a SCLK signal at exactly 2.048 MHz. Otherwise use of a 4.0 MHz crystal is recommended. Operation at 4.0 MHz provides an SCLK at 2.000 MHz.		3.8912	4.000	MHz
T <sub>A</sub> operating free-air temperature	0		70	°C

The following circuit is recommended for driving the CT8020 RESET pin in order to meet the V<sub>IH</sub> spec for this pin:

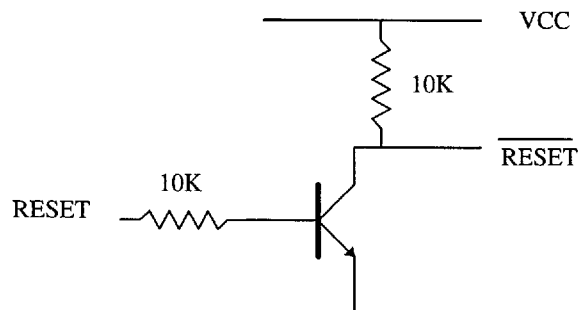

**Electrical characteristics over recommended operating free-air temperature range  
(unless otherwise noted)**

PARAMETER	TEST CONDITIONS	MIN	TYP	MAX	UNIT
V <sub>OH</sub> high level output voltage	VCC = 5V	2.4			V
V <sub>OL</sub> low level output voltage				0.6	V
I <sub>OZ</sub> off state output current	VCC = Max			20	μA
I <sub>I</sub> input current (pins without pull down resistors)				±20	μA
I <sub>I</sub> input current (pins with pull down resistors)				+20 -60	μA
ICC Supply Current	Operating Mode	f = 40 Mips	260	280	mA
	Stop Device Mode	VCC = 5V	0.5	2	mA
	No Clock 25 °C all inputs GND all outputs NC	VCC = 5V	50		uA
CI Input capacitance				20	pF

**DTMF & Tone Generation Characteristics**

PARAMETER	MIN	TYP	MAX	UNIT
DTMF twist (high/low tone)		2	±8	dB
Tone generator frequency accuracy	-0.1		+0.1	%fc
Tone generator level*	-24		+6	dB0
Tone generator level accuracy	-0.5		+0.5	dB

\* 0 dB0 is 0.707 Vrms programmable with 2 dB resolution. Assumes FSYNC = 8.000 KHz

**Acoustic echo cancellor performance**

PARAMETER		NOTE
Acoustic Echo Cancellation	30 dB	1
Max echo delay	10 ms	2,3

Notes:

1. The acoustic echo cancellor acheives 30 dB of cancellation for white noise in less than 1.0 seconds with the speaker codec output connected to the microphone codec input via a 2:1 attenuator and an output level equivalent to -10 dBm0.
2. The acoustic echo cancellor can cancel echos up to 10 ms (approximately 3.4 meters or 11 feet in sound propagation).
3. Assumes operation of codec at 8.0 KHz sample rate

**Electrical echo cancellor performance**

<b>PARAMETER</b>		<b>NOTE</b>
Training pulse duration	16ms	1
Echo duration	23.25ms	1
Canceler length	7.38 ms	1,2
Training pulse peak amplitude	350 mV	3
Training pulse average peak amplitude	250 mV	3
Electrical echo cancellation	34 dB	4

## Notes:

1. Assumes operation of codec at 8.0 KHz sample rate.
2. The electrical echo cancellor will model the impulse response of the attached line curcuit for an impulse response up to this duration.
3. Measured at the codec output pin using a TP3054 Texas Instruments mu-law codec.
4. The electrical echo cancellor will acheive 34 dB cancellation for white noise with the line codec output short circuit connected to the line codec input.

### 13. Mechanical Data - CT8020

