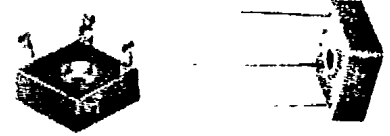

CENTER TAP RECTIFIERS

T-23-07

OPERATING TEMPERATURE RANGE: -55°C to +125°C
 STORAGE TEMPERATURE RANGE: -55°C to +150°C

TYPE	Maximum Peak Reverse Voltage	Maximum Average Rectified Current @ Half-Wave Resistive Load 60Hz		Maximum Forward Peak Surge Current @ 8.3 ms Superimposed	Maximum Reverse Current @ PRV @ 25°C TA	Maximum Forward Voltage @ 25°C TA	
	PRV	I _o @ TA		I _{FM} (Surge)	I _R	I _{FM}	V _{FM}
	V _{PK}	AAV	°C	APK	μA _{dc}	APK	V _{PK}

25 AMPERES/CT-25**CTP: POSITIVE CENTER-TAP; CTN: NEGATIVE CENTER-TAP**

CTP2505/CTN2505	50	25	50	400	10.0	6.0	1.0
CTP251/CTN251	100	25	50	400	10.0	6.0	1.0
CTP252/CTN252	200	25	50	400	10.0	6.0	1.0
CTP254/CTN254	400	25	50	400	10.0	6.0	1.0
CTP256/CTN256	600	25	50	400	10.0	6.0	1.0
CTP258/CTN258	800	25	50	400	10.0	6.0	1.0
CTP2510/CTN2510	1000	25	50	400	10.0	6.0	1.0

35 AMPERES/CT-25**CTP: POSITIVE CENTER-TAP; CTN: NEGATIVE CENTER-TAP**

CTP3505/CTN3505	50	35	50	400	10.0	6.0	1.0
CTP351/CTN351	100	35	50	400	10.0	6.0	1.0
CTP352/CTN352	200	35	50	400	10.0	6.0	1.0
CTP354/CTN354	400	35	50	400	10.0	6.0	1.0
CTP356/CTN356	600	35	50	400	10.0	6.0	1.0
CTP358/CTN358	800	35	50	400	10.0	6.0	1.0
CTP3510/CTN3510	1000	35	50	400	10.0	6.0	1.0

OUTLINE OF RECTIFIERS

Unit: Inch (mm)

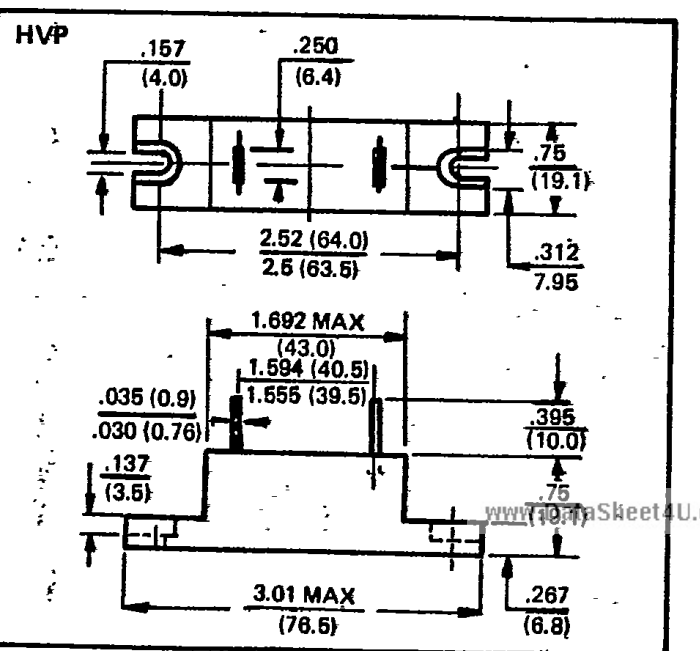
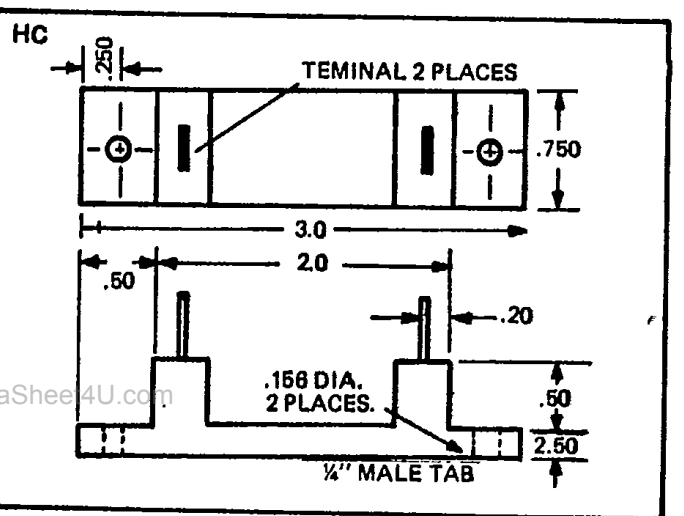
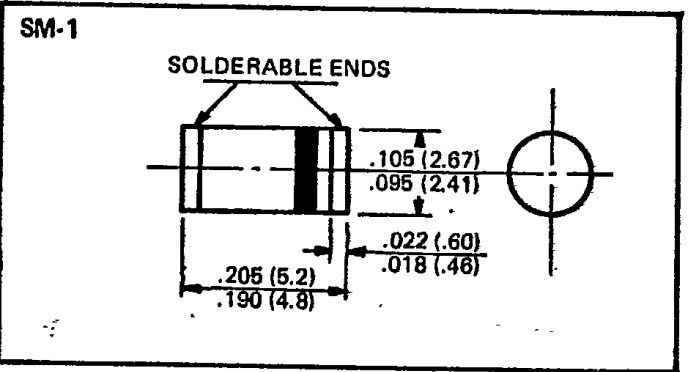
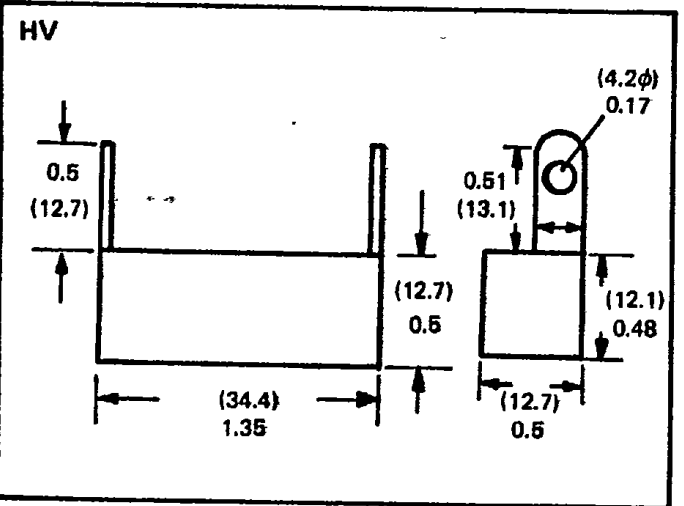
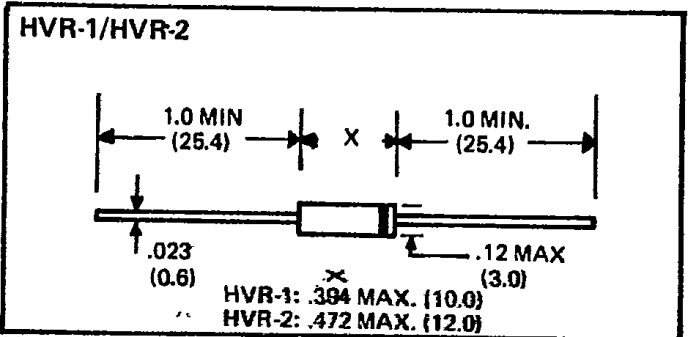
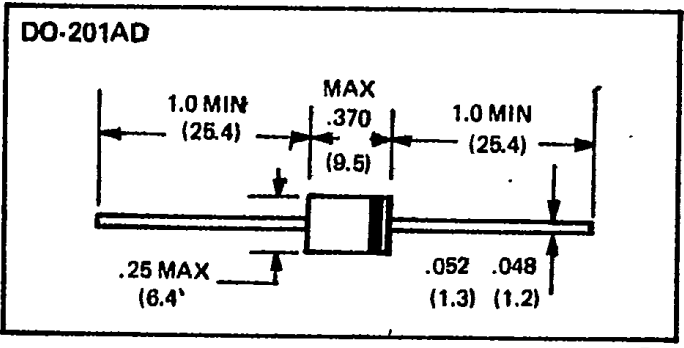
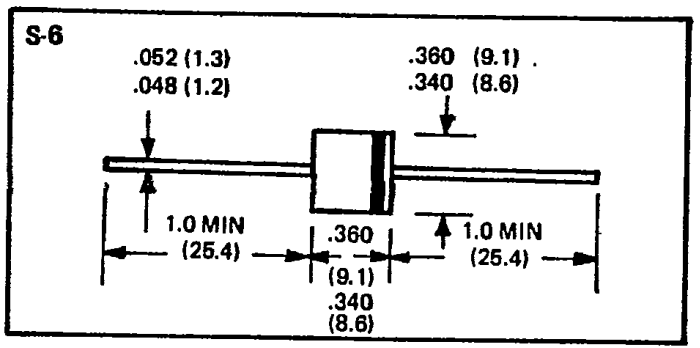
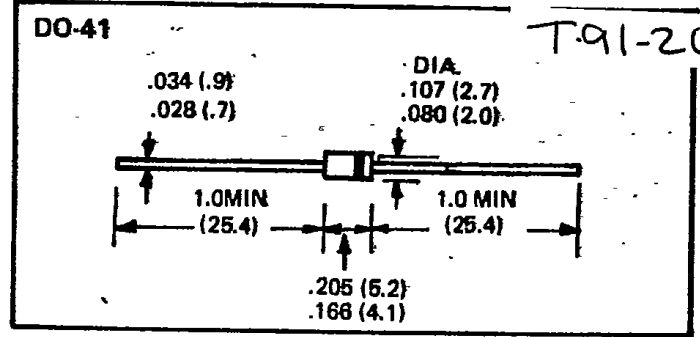
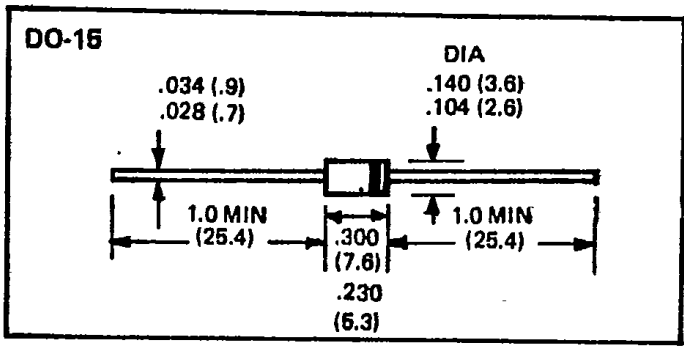

OUTLINE OF BRIDGE RECTIFIERS

Unit: Inch (mm)

DB-1

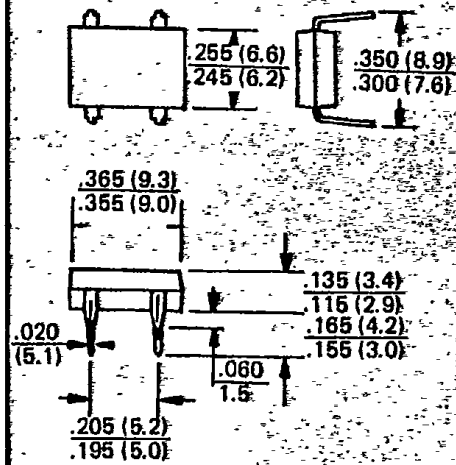

RS1

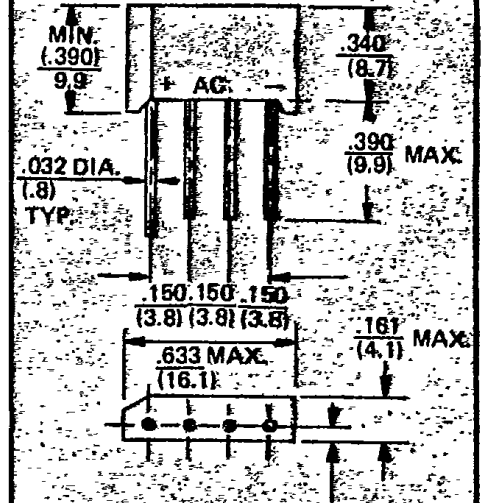

RB-15/WOL

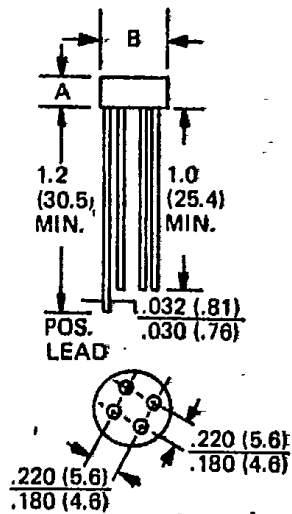

NOTE:

	A	B
RB 15	.138 (3.5)	.358 (9.1)
WOL	.280 (7.1)	.378 (9.6)

WOM/RC-2

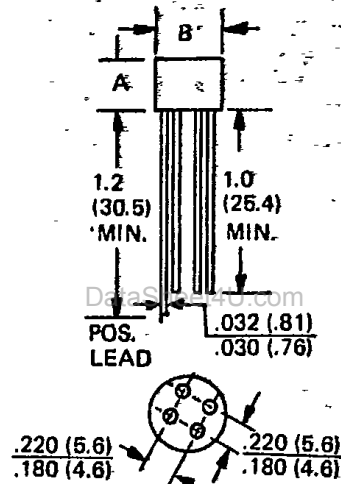

NOTE:

	A	B
WOM	.220 (5.6)	.340 (8.6)
RC-2	.210 (5.1)	.300 (7.6)
RC-2	.280 (7.1)	.394 (10.0)

RS2

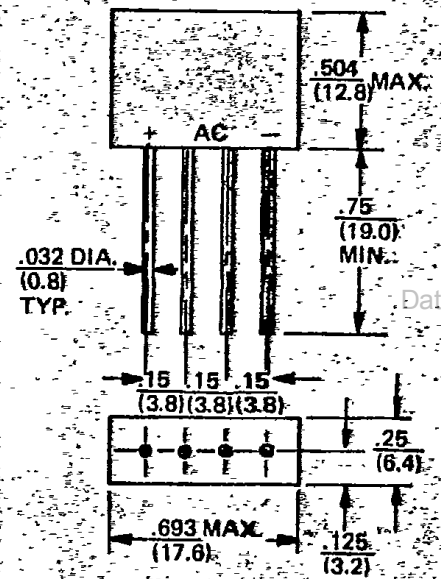

BR-3

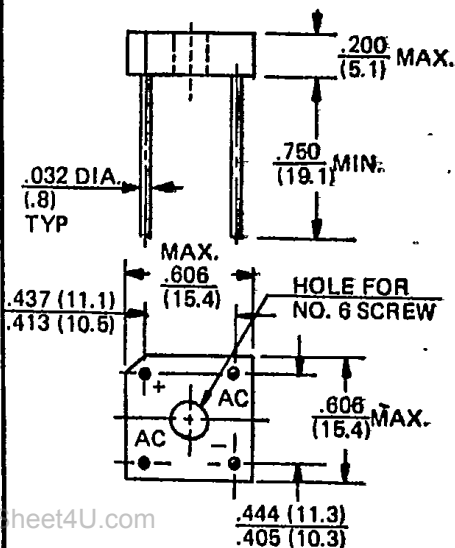

RS-4

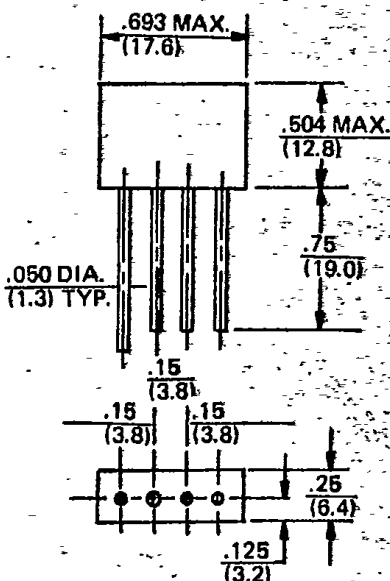

RS-4L

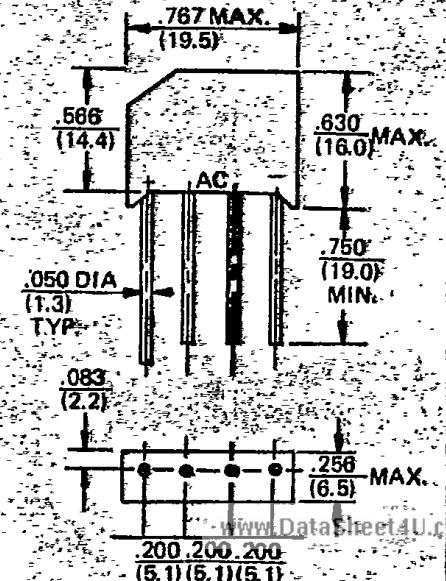

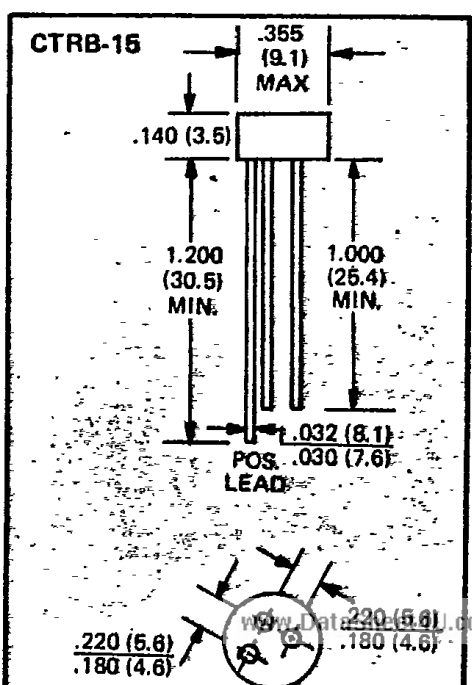
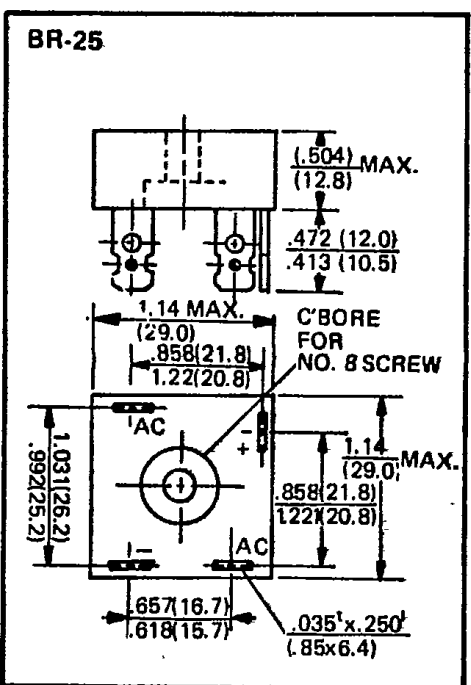
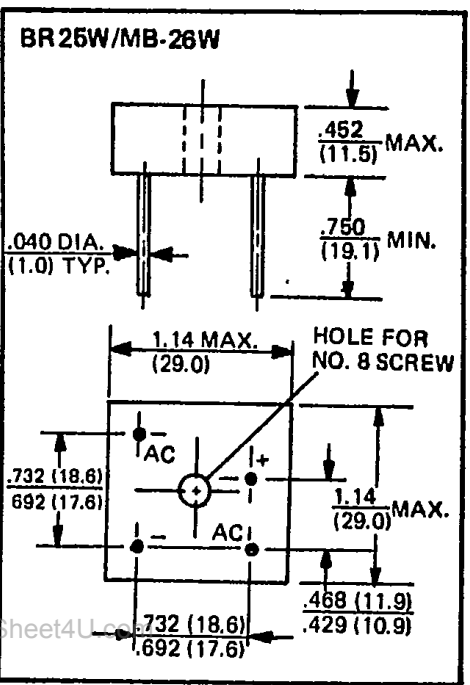
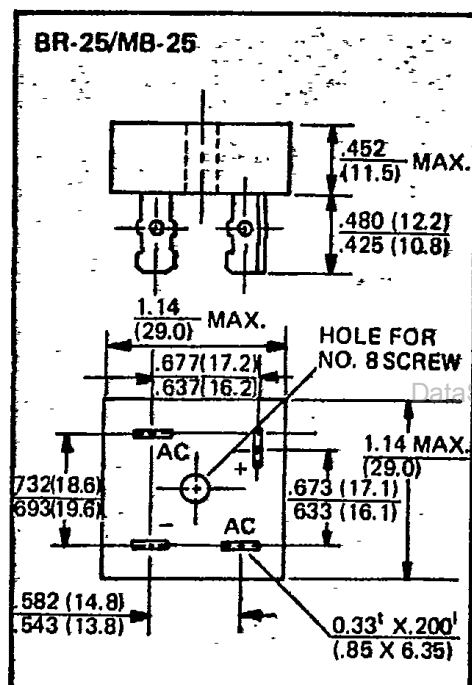
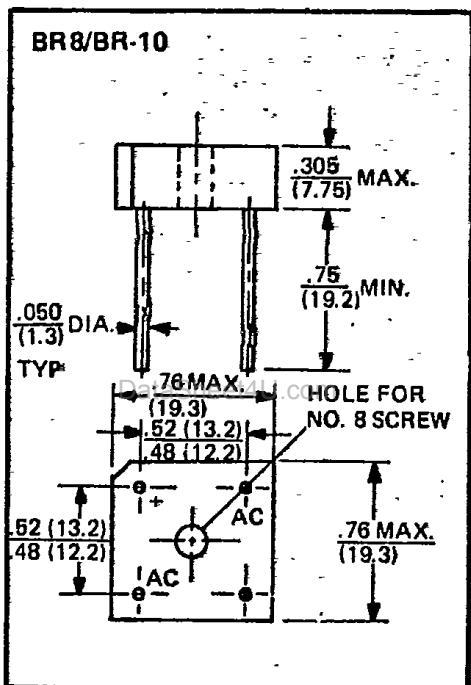
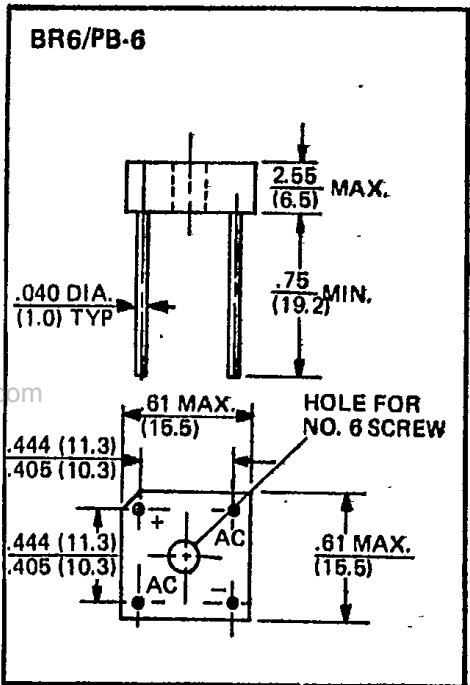
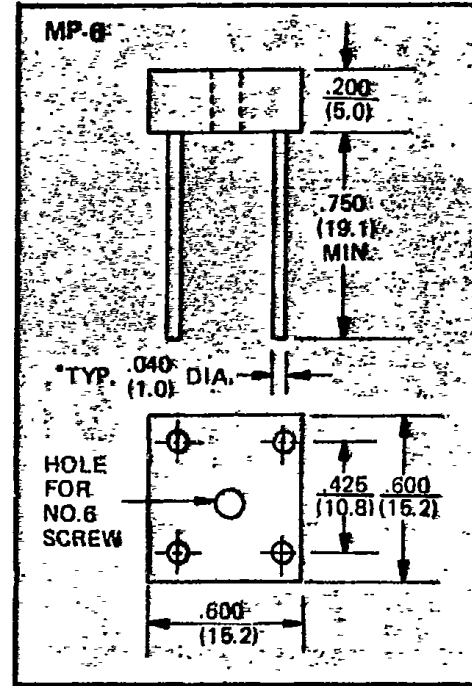
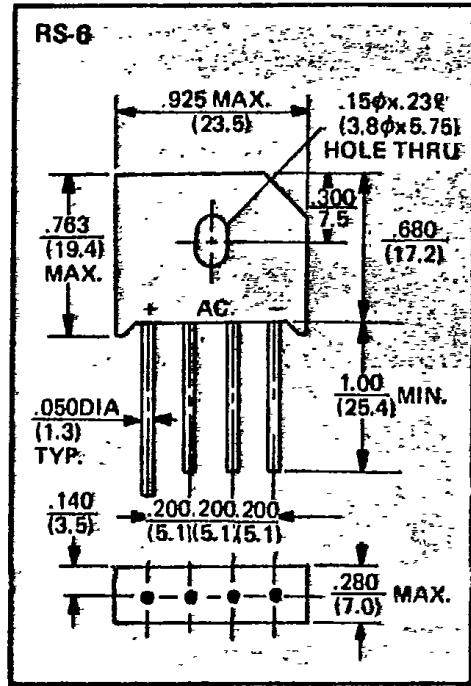
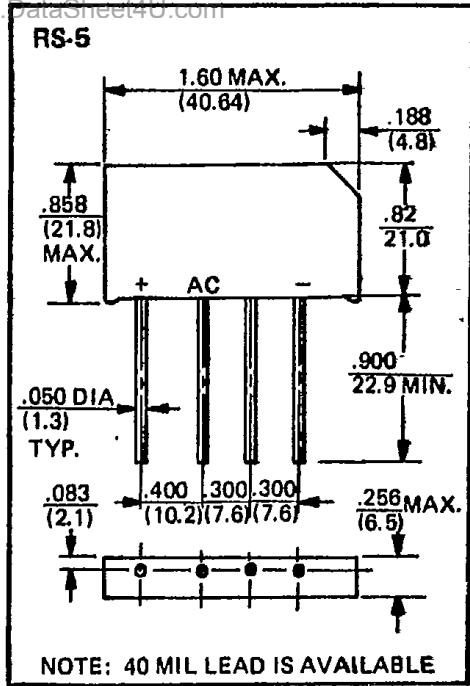

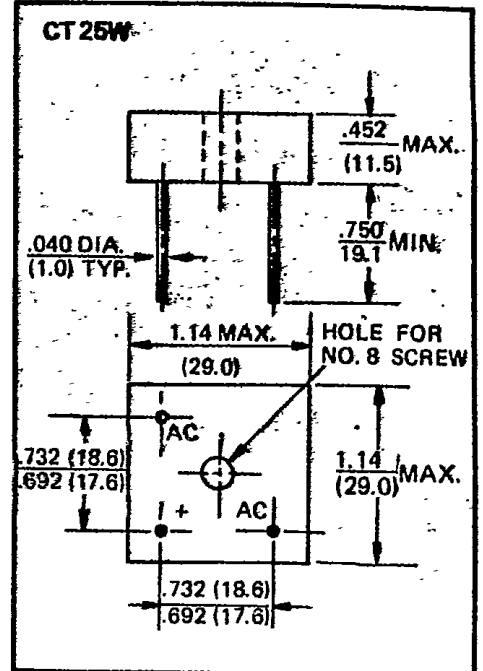
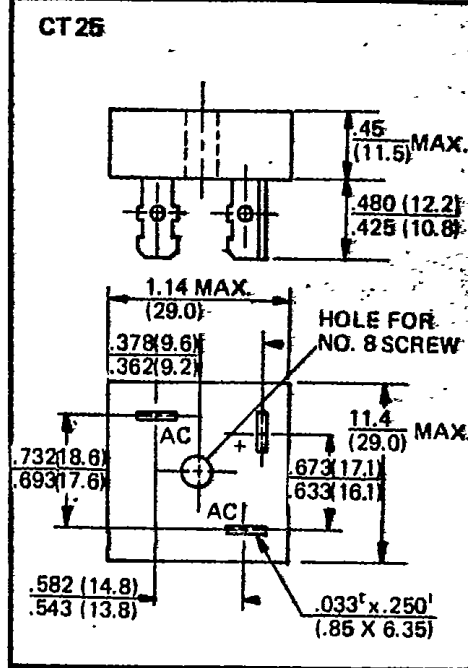
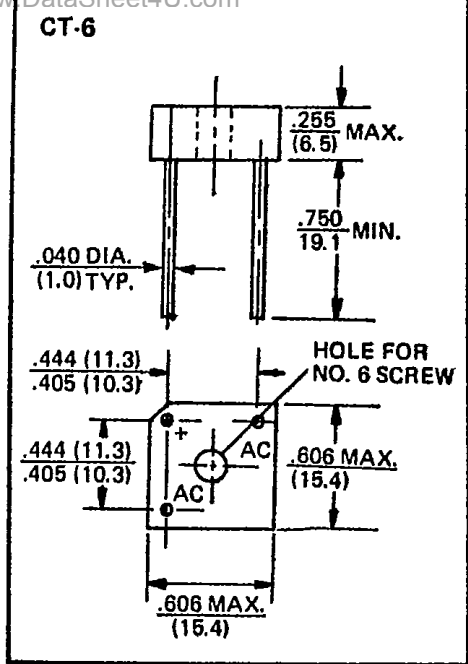

BULK PACK

Device	INNER SIZE (m/m)	BOX (EA)	CARTON SIZE (m/m)	CARTON (KEA)	APPROX. GROSS WEIGHT (Kg)
DO-41	200x84x21	1,000	451x205x254	50,000	19.8
DO-15	200x84x21	500	451x205x254	25,000	13.0
HVR-1/HVR-2	200x84x21	500	451x205x254	25,000	23.8
DO-201AD	303x73x40	500	330x310x268	12,000	17.2
S-6 (6A)	303x73x40	200	330x310x268	4,800	12.8
RS-1	255x168x61	1,000	330x310x268	10,000	19.1
RS-2	160x208x51	400	457x215x258	4,000	13.2
BR-3	207x207x53	200	457x215x258	1,600	7.15
RB-15	255x168x61	1,000	330x310x268	10,000	18.7
RS-4	237x237x43	400	494x245x285	4,000	17.34
RS-4L	237x237x43	400	494x245x285	4,000	21.37
RS-5	237x237x43	200	494x245x285	2,000	21.5
BR-6/PB-6	207x207x53	200	457x215x258	1,600	8.865
RS-6	237x237x43	200	494x245x285	2,000	13.315
BR-8/BR-10	224x224x48	200	494x245x285	2,400	20.3
BR-15 BR-25 BR-35	207x207x53	50	457x215x258	400	18.2
BR-15W BR-25W BR-35W	207x207x53	50	457x215x258	400	11.63
RB15/WOM	250x160x57	1,000	343x322x267	10,000	13.7
MP6	207x207x53	200	451x205x254	16,000	7.0
DB-1	490x145x85	2,500	510x365x310	20,000	14.4
WOL	250x160x57	600	343x322x267	6,000	13
HV	225x225x40	100	451x205x254	1,000	11.6
HC	207x207x53	40	451x205x254	320	10.2
HVP	207x207x53	40	451x205x254	320	11.8
ZENER	200x84x21	1,000	451x205x254	50,000	13.1

REEL PACK

DEVICE	REEL (EA)	COMPONENT SPACE (m/m)	TAPE SPACE (m/m)	REEL DIA (m/m)	CARTON SIZE (m/m)	APPROX GROSS WEIGHT (Kg)
DO-41	5,000	5.0	51	330	350x350x345	10.5
DO-15	4,000	5.0	51	330	350x350x345	10.0
HVR-1/HVR-2	3,000	5.0	51	330	350x350x345	14.2
DO-201AD	1,200	9.5	51	330	350x350x345	9.2
S-6	500	9.5	51	330	350x350x345	7.3

AMMUNITION PACK

DEVICE	BOX (EA)	COMPONENT SPACE (m/m)	TAPE SPACE (m/m)	BOX SIZE (m/m)	CARTON SIZE (m/m)	CARTON (EA)	APPROX GROSS WEIGHT (Kg)
DO-41	3,000	5.0	51	255x78x95	350x350x345	4,800	18.3
DO-15	2,200	5.0	51	255x78x95	350x350x345	33,000	18.3
HVR-1/HVR-2	2,000	5.0	51	255x78x95	350x350x345	30,000	27.2
DO-201AD	800	9.5	51	255x78x95	350x350x345	12,000	17.4
S-6	300	9.5	51	255x78x95	350x350x345	4,500	11.9
DO-41	3,000	5.0	26	255x51x95	330x310x268	42,000	15.1
DO-15	2,200	5.0	26	255x51x95	330x310x268	37,400	13.6