

Vacuum Fluorescent Display Module Specification

Model: CU20027-Y1A

Specification No:	DS-1557-0001-02
Date of Issue:	December 5, 2008 (00)
Revision:	December 17, 2008 (01) February 19, 2010 (02)

Published by
NORITAKE ITRON CORP. / Japan
<http://www.noritake-itron.jp>

This specification is subject to change without prior notice.

This product complies with RoHS Directive 2002/95/EC

Index

1	General Description	4
1.1	Scope.....	4
1.2	Features.....	4
1.3	Hardware Configuration.....	5
2	Electrical Specifications	5
2.1	Absolute Maximum Ratings.....	5
2.2	Electrical Ratings.....	5
2.3	Electrical Characteristics	6
3	Environmental Specifications	6
4	Optical Specifications	7
5	Physical Specifications.....	7
6	Applicable Specifications	7
7	Interface.....	7
7.1	Parallel Interface.....	8
7.1.1	Basic Operation	8
7.1.2	Flowchart.....	8
7.1.3	Interface Timing.....	9
7.2	Serial Interface.....	10
7.2.1	Basic Operation	10
7.2.2	Flowchart.....	10
7.2.3	Asynchronous Serial Interface Timing.....	11
7.2.3.1	Data write.....	11
7.2.3.2	Data read	11
7.2.4	Synchronous Serial Interface Timing.....	12
7.3	Reset Timing.....	12
8	Jumper Setting.....	13
8.1	Jumper location	13
8.1.2	Serial Synchronous / Asynchronous Interface Select.....	13
8.1.3	Test Mode	13
9	Operating Mode	14
9.1	Direct Command Mode.....	14
9.2	User Set up Mode.....	14
9.3	Diagnostic Serial OUT Mode.....	14
9.4	Test mode	14
10	Font Table Configuration	15
11	Character Fonts specification	16
11.1	Common Font Set (20h – 7Fh).....	16
11.2	Alternative 5x7 Matrix font.....	16
11.3	Alternative Magnified font (20h – 7Fh)	17
11.4	International Font Set	18

11.5	<i>Character Table Type (80h – FFh)</i>	19
12	Display Area End-of-Line Behavior	22
13	Initial settings	23
14	Commands	23
14.1	<i>Command Configuration</i>	23
14.2	<i>Command Set</i>	24
14.3	<i>Detail of Command Set</i>	25
14.3.1	Character display	25
14.3.2	Standard Ascii control codes	26
14.3.2.1	Back Space	26
14.3.2.2	Horizontal Tab	26
14.3.2.3	Line Feed	27
14.3.2.4	Home Position	27
14.3.2.5	Display Clear.....	27
14.3.2.6	Carriage Return	27
14.3.3	Insert/Delete commands	27
14.3.3.1	Character Insert	27
14.3.3.2	Character Delete.....	27
14.3.3.3	Line Insert	28
14.3.3.4	Line Delete.....	28
14.3.4	Cursor commands	28
14.3.4.1	Cursor set	28
14.3.4.2	Cursor Underline.....	28
14.3.4.3	Cursor Underline Blink.....	28
14.3.4.4	Cursor Block	28
14.3.4.5	Cursor Off	29
14.3.5	Character format commands	29
14.3.5.1	Underline ON	29
14.3.5.2	Underline OFF	29
14.3.5.3	Blink ON.....	29
14.3.5.4	Blink OFF	29
14.3.5.5	Brightness (character)	29
14.3.5.6	International Font set.....	30
14.3.5.7	Character Table type.....	30
14.3.5.8	5x8 Matrix font.....	31
14.3.5.9	Font Magnification	31
14.3.5.10	Alternative Magnified Font	31
14.3.6	Custom font commands	32
14.3.6.1	RAM user font.....	32
14.3.6.2	RAM user font Define	32
14.3.6.3	RAM user font Delete	33

14.3.7	Screen Action Commands	33
14.3.7.1	Brightness (screen).....	33
14.3.7.2	Blink (screen).....	33
14.3.7.3	Blink speed	34
14.3.7.4	Wait.....	34
14.3.7.5	Screen saver.....	34
14.3.8	Display Mode Commands	35
14.3.8.1	Over-write mode	35
14.3.8.2	Vertical scroll mode.....	35
14.3.8.3	Horizontal scroll mode	35
14.3.8.4	Horizontal scroll speed	35
14.3.8.5	Write Mode - Quick.....	35
14.3.8.6	Write Mode - Flickerless	35
14.3.8.7	Initialize Display	36
14.3.8.8	Reset.....	36
14.3.9	User setup mode Commands	36
14.3.9.1	User set up mode start	36
14.3.9.2	FROM user font Define.....	36
14.3.9.3	Status information Display	37
14.3.9.4	User set up mode end	37
14.3.10	Diagnostic Serial OUT mode commands	38
14.3.10.1	Diagnostic Serial OUT mode start	38
14.3.10.2	Diagnostic Status information Read.....	38
14.3.10.3	Diagnostic Serial OUT mode end	38
15	Connectors	39
15.1	<i>Parallel interface connector (Fourteen through-holes / CN1)</i>	39
15.2	<i>Serial interface connector (Six through-holes / CN3)</i>	39
15.2.1	If Asynchronous serial interface is selected.	39
15.2.2	If Synchronous serial interface is selected.	39
16	Firmware Version Notation	39
17	Physical Dimensions	40
	Notice for the Cautious Handling of VFD Modules	41
	Revision history	42

1 General Description

1.1 Scope

This specification covers the operation and operating requirements of the Vacuum Fluorescent Display (VFD) module CU20027-Y1A.

This specification is applicable for firmware version F095 or later.

1.2 Features

- Functions
 - Character highlight
 - Easy-to-use ASCII commands and fonts
 - Character magnification
 - Screen saver
 - Blink display (character or screen)
- Display
 - Vivid green indication
 - Wide viewing angle
 - High brightness (Typ. 2000 cd/m² – up to 2 times higher than previous displays)
 - Brightness levels: 8 levels of overall display brightness with 8 relative levels for each individual 5×8 matrix
- Font
 - New 5×8 matrix character font
 - Many international font sets
 - RAM user-definable characters (16 characters)
 - FROM user-definable characters (224 characters)
 - 40 (20×2) characters on the compact display area
- Interface
 - CMOS signal level
 - Parallel Interface: i80 type 8-bit bus
 - Serial interface: Synchronous or Asynchronous, selected by jumper setting
- Operation
 - DC 5V input
 - Wide operating temperature range (-40 to +85 °C)

1.3 Hardware Configuration

The module consists of:

- 20x2 character display (VFD)
- Refresh RAM
- Character generator
- DC/DC converter (supplies all necessary power for VFD)
- Display controller
- All necessary control logic circuits

1.3.1 Block Diagram

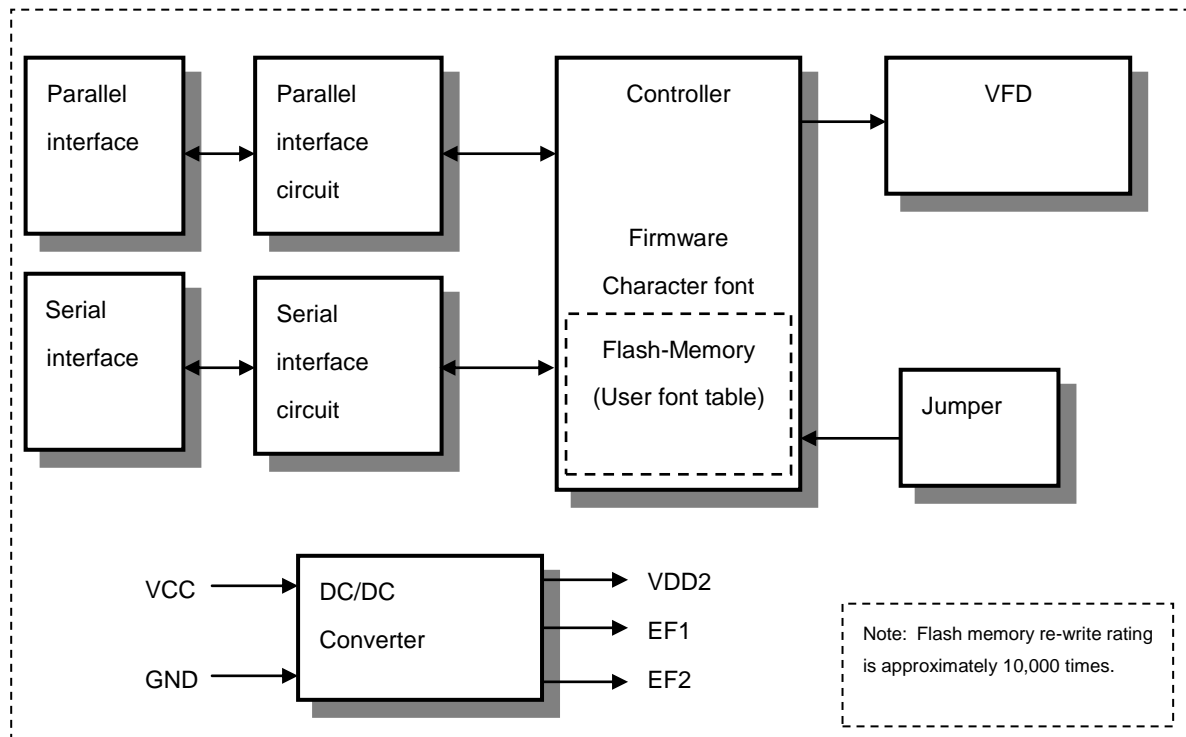

2 Electrical Specifications

2.1 Absolute Maximum Ratings

Parameter	Symbol	Min.	Typ.	Max.	Unit
Power Supply Voltage	V_{CC}	-0.3	-	+6.0	V_{DC}
Logic Input Voltage D0-D7, /WR, SIN, SCK, /RESET	V_{IN}	-0.3	-	$V_{CC}+0.3$	V_{DC}

2.2 Electrical Ratings

Parameter	Symbol	Min.	Typ.	Max.	Unit
Power Supply Voltage	V_{CC}	4.75	5.0	5.25	V_{DC}

2.3 Electrical Characteristics

Measuring Conditions: Ambient temperature = 25 °C, $V_{CC} = 5.0 V_{DC}$

Parameter		Symbol	Min.	Typ.	Max.	Unit	Condition	Note
'L' Level Logic Input Current	D0-D7, /WR, /RESET	I_{IL1}	-	-	-0.15	mA	$V_{IN} = 0V$	-
	SIN, SCK	I_{IL2}	-	-	-0.55	mA	$V_{IN} = 0V$	-
'H' Level Logic Input Current	D0-D7, SIN, SCK	I_{IH1}	-	-	5.0	μA	$V_{IN} = 5V$	-
	/WR, /RESET	I_{IH2}	-	-	0.25	μA	$V_{IN} = 5V$	-
'L' Level Logic Input Voltage	D0-D7, /WR, SIN, SCK	V_{IL1}	0	-	$0.2 \times V_{CC}$	V_{DC}	-	-
	/RESET	V_{IL2}	0	-	0.8	V_{DC}	-	-
'H' Level Logic Input Voltage	D0-D7, /WR, /RESET, SIN, SCK	V_{IH}	$0.8 \times V_{CC}$	-	V_{CC}	V_{DC}	-	-
'L' Level Logic Output Voltage	PBUSY	V_{OL1}	-	-	0.1	V_{DC}	$I_{OL} = 50\mu A$	-
	SBUSY	V_{OL2}	-	-	0.45	V_{DC}	$I_{OL} = 200\mu A$	-
'H' Level Logic Output Voltage	PBUSY	V_{OH1}	$V_{CC}-0.1$	-	-	V_{DC}	$I_{OH} = -50\mu A$	-
	SBUSY	V_{OH2}	$V_{CC}-0.5$	-	V_{CC}	V_{DC}	$I_{OH} = -200\mu A$	-
Power Supply Current		I_{CC1-1}	-	240	300	mA_{DC}	Brightness 100%	(1)
		I_{CC2-1}	-	200	250	mA_{DC}	Brightness 100%	(2)
		I_{CC1-2}	-	320	400	mA_{DC}	Brightness 200%	(1)
		I_{CC2-2}	-	250	310	mA_{DC}	Brightness 200%	(2)
		I_{CC3}	-	25	35	mA_{DC}	Power Save Mode	(3)
Power Consumption			-	1.2	1.5	W	Brightness 100%	(1)
			-	1.6	2.0	W	Brightness 200%	(1)

(1) I_{CC1} is the current when all dots in the display are on.

(2) I_{CC2} is the current when all dots in the display are off.

(3) I_{CC3} is the current in Power Save Mode (refer to 14.3.7.5 Screen saver command, page 34).

Note: A slow start power supply may cause erroneous operation. I_{CC} can be approximately twice the specified supply current at power on.

3 Environmental Specifications

Operating temperature: -40 to +85 °C

Storage temperature: -40 to +85 °C

Operating humidity: 20 to 80 % R.H (non-condensing)

Storage humidity: 20 to 80 % R.H (non-condensing)

Vibration: 10-55-10Hz, all amplitude 1mm, 30 minutes, X-Y-Z (non-operating)

Shock: 392m/s² (40G) 9ms X-Y-Z, 3 times each direction (non-operating)

4 Optical Specifications

Luminance:	Minimum:	350 cd/m ²
	Typically:	1000 cd/m ² (100% brightness)
		2000 cd/m ² (200% brightness)

Color of illumination: Green (Blue Green)

5 Physical Specifications

Number of characters:	40 (20 characters×2 lines)
Matrix format:	5×8 dots
Display area:	73.4×15.0 mm (X×Y)
Character size:	2.72×7.19 mm (X×Y)
Character pitch:	3.72 mm
Line pitch:	7.81 mm
Dot size:	0.44×0.785 mm (X×Y)
Dot pitch:	0.57×0.915 mm (X×Y)
Weight:	Approximately 48g

6 Applicable Specifications

Applicable reliability spec.:	TT-99-3102
Applicable production spec.:	TT-98-3413

7 Interface

CMOS signal level

Parallel Interface: i80 type 8-bit bus

Serial Interface: Synchronous or Asynchronous, selected by jumper setting

The module cannot receive both serial and parallel data at the same time.

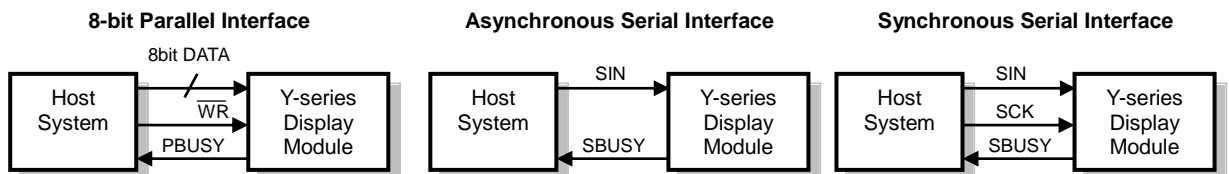

Monitoring the busy line is recommended, to prevent data loss, and to minimize the delay time for processing subsequent commands / data.

7.1 Parallel Interface

7.1.1 Basic Operation

Data (D0-D7) has to be set prior to a rising edge of \overline{WR} line, and the data is clocked in on the rising edge of \overline{WR} line.

During data execution, the parallel busy line is high (PBUSY=1).

Writing data when PBUSY=1 causes data loss, so data must be written when PBUSY=0.

7.1.2 Flowchart

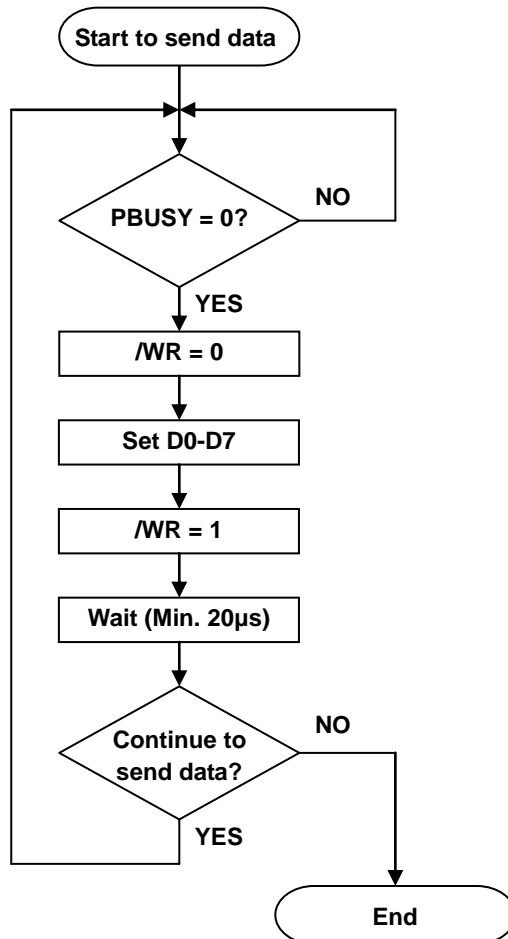

7.1.3 Interface Timing

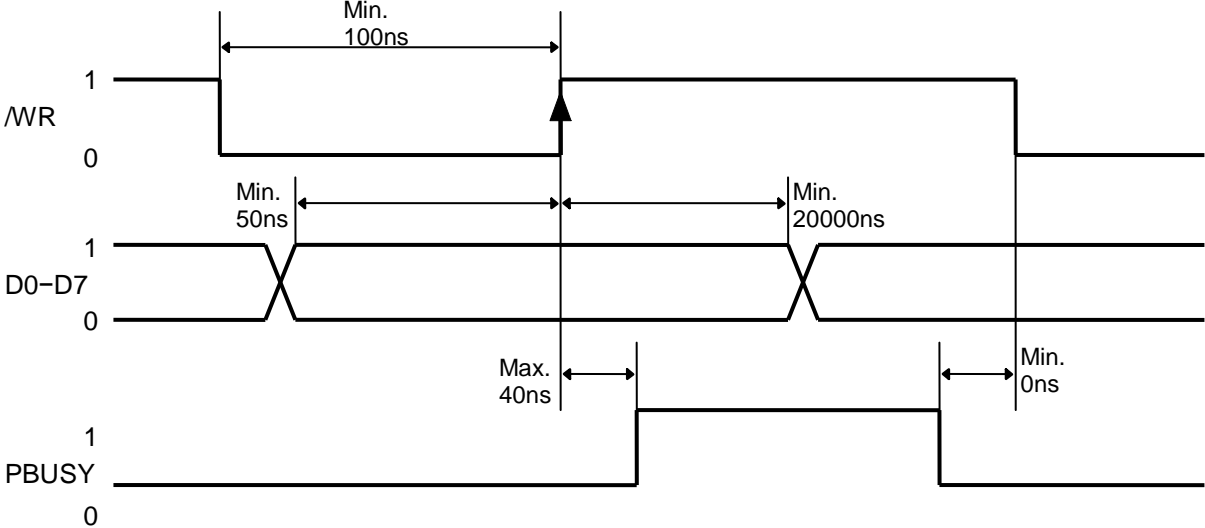

Note: Data must be written when PBUSY=0 to prevent data loss.

7.2 Serial Interface

7.2.1 Basic Operation

Default setting: Asynchronous (Baud rate = 38,400bps)

Synchronous or Asynchronous is selected by jumper setting (refer to 8 Jumper Setting, page 13). The capacity of the receive buffer is 64 bytes. The relationship between SBUSY and the state of the receive buffer is as follows:

	Remaining space in receive buffer
SBUSY 0→1	24 bytes or less
SBUSY 1→0	32 bytes or more

Writing data when SBUSY=1 may cause data loss, so data should be written when SBUSY=0.

7.2.2 Flowchart

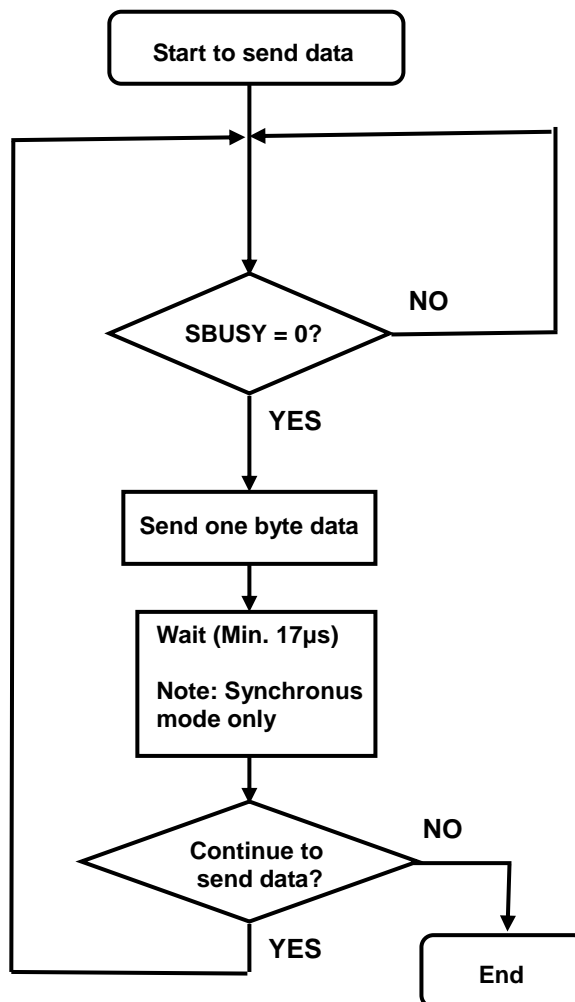

7.2.3 Asynchronous Serial Interface Timing

7.2.3.1 Data write

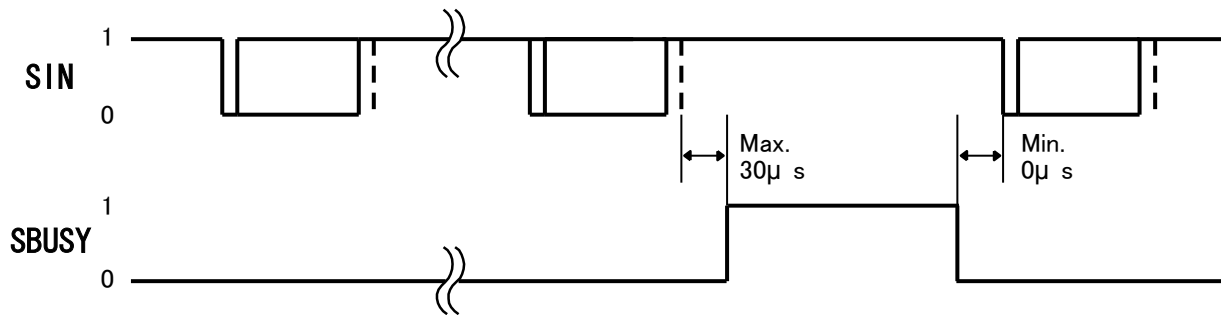

Protocol:

Baud rate	9,600 – 115,200bps (Selected by jumper) Default: 38,400bps
Parity	None
Format	Start(1bit) + Data(8bit) + Stop(1bit)
Handshake	SBUSY

Note: Monitoring the serial busy line (SBUSY) is recommended, to prevent data loss, and to minimize the delay time for processing subsequent commands / data. Data should be written when SBUSY=0.

7.2.3.2 Data read

This is used for “Diagnostic Status information Read” command only.

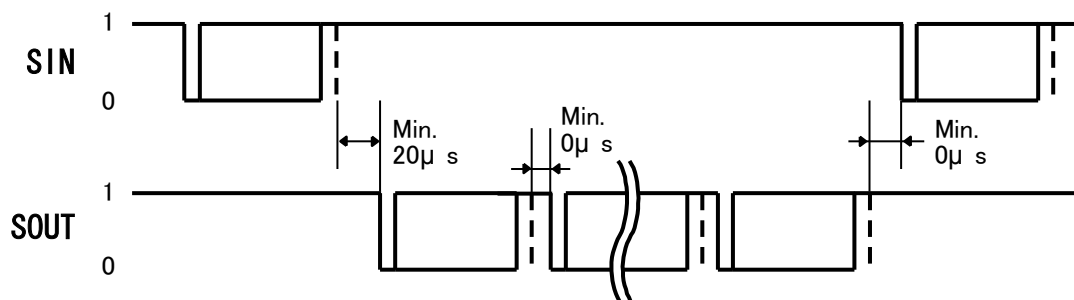

Protocol:

Baud rate	9,600 – 115,200bps (Selected by jumper) Default: 38,400bps
Parity	None
Format	Start(1bit) + Data(8bit) + Stop(1bit)
Handshake	None

Note: Output data is transferred immediately from the VFD module, so a receive buffer may be required on the host system to prevent data loss.

7.2.4 Synchronous Serial Interface Timing

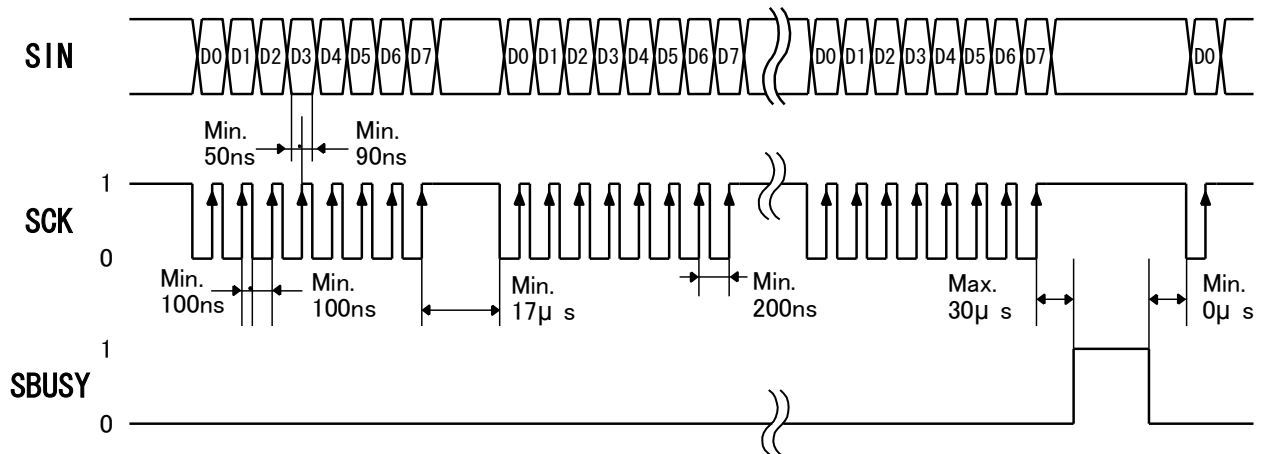

Note: Monitoring the serial busy line (SBUSY) is recommended, to prevent data loss, and to minimize the delay time for processing subsequent commands / data. Data should be written when SBUSY=0.

7.3 Reset Timing

Reset pulse (active low) should be at least 1ms.

The module sets the SBUSY/PBUSY line upon receipt of Reset signal and clears the line when ready to receive data.

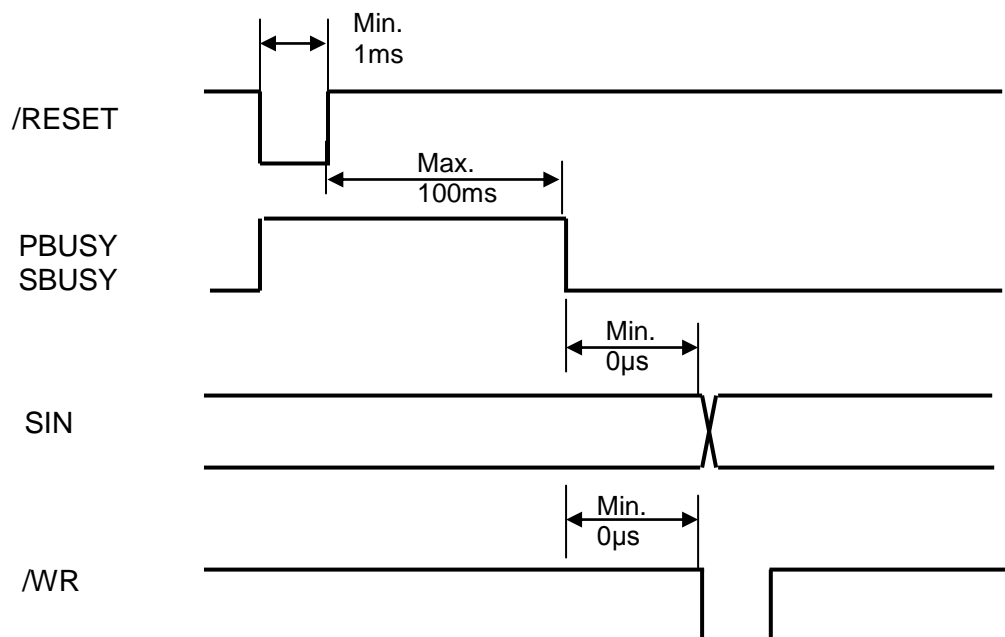

8 Jumper Setting

8.1 Jumper location

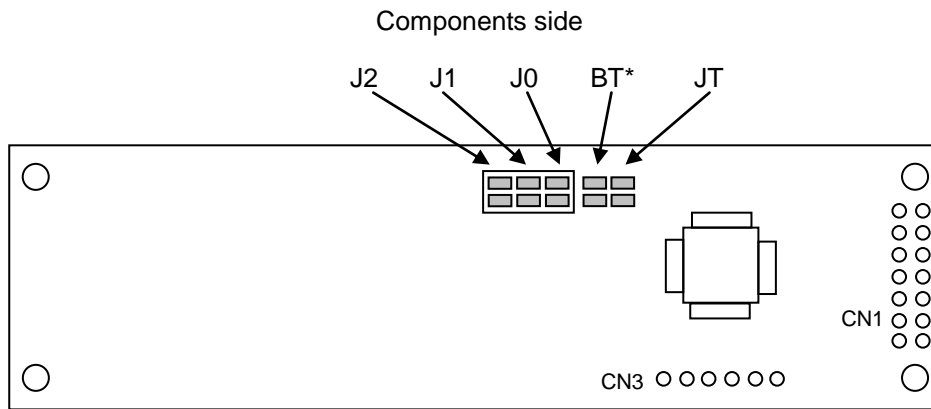

Note: Jumper “BT” is for factory use only. **Do not use.**

8.1.1 Baud Rate Setting (for Asynchronous Serial Interface only)

Baud Rate	J0	J1
38,400bps (default)	OPEN	OPEN
19,200bps	SHORT	OPEN
9,600bps	OPEN	SHORT
115,200bps	SHORT	SHORT

8.1.2 Serial Synchronous / Asynchronous Interface Select

Serial Interface	J2
Asynchronous (default)	OPEN
Synchronous	SHORT

8.1.3 Test Mode

Refer to 9.4 Test mode.

Mode	JT
Direct Command Mode (default)	OPEN
Test Mode	SHORT

9 Operating Mode

This module has the following operating modes, selected by commands or jumper settings.

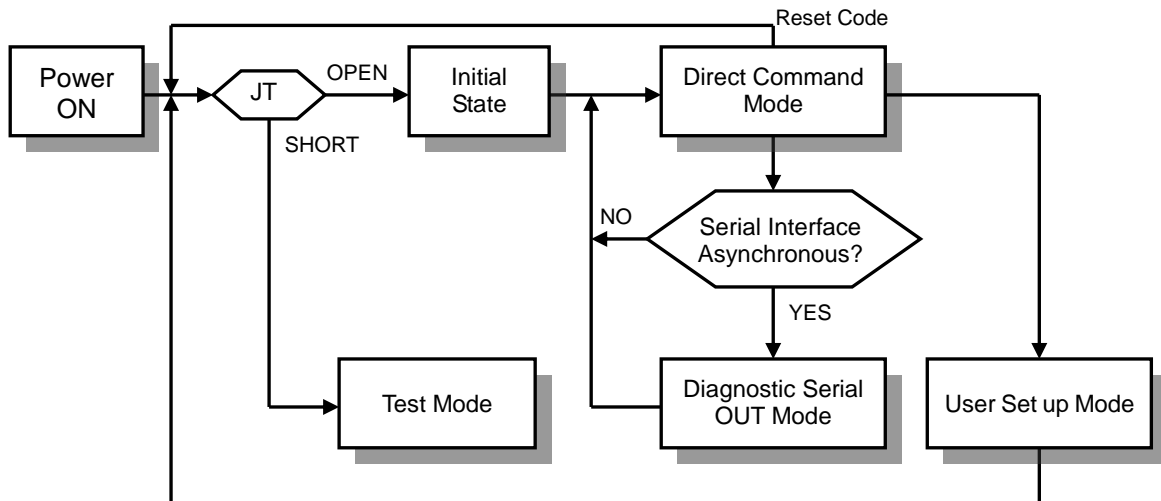

9.1 Direct Command Mode

The module accepts data and all commands except 14.3.9.2 FROM user font Define, 14.3.9.3 Status information Display, 14.3.9.4 User set up mode end, 14.3.10.2 Diagnostic Status information Read, and 14.3.10.3 Diagnostic Serial OUT mode end.

9.2 User Set up Mode

In this mode, the on-board flash memory can be written to.

The module accepts only three commands: 14.3.9.2 FROM user font Define, 14.3.9.3 Status information Display, and 14.3.9.4 User set up mode end.

9.3 Diagnostic Serial OUT Mode

In this mode, status information can be read via the Asynchronous Serial Interface.

The module accepts only two commands: 14.3.10.2 Diagnostic Status information Read and 14.3.10.3 Diagnostic Serial OUT mode end.

9.4 Test mode

The module does not accept any commands but displays test patterns. For test purpose only.

10 Font Table Configuration

This display's Font Table (20h–FFh) is configured as follows. The configuration can be changed by command.

The Font Table used in the default state is as follows.

	2 x H	3 x H	4 x H	5 x H	6 x H	7 x H	8 x H	9 x H	A x H	B x H	C x H	D x H	E x H	F x H
x0H		0	1	P	p									
x1H	!	1	A	a	q									
x2H	"	2	B	b	r									
x3H	⊗	3	C	c	s									
x4H	⊗	4	D	d	t									
x5H	%	5	E	e	u									
x6H	&	6	F	f	v									
x7H	^	7	G	g	w									
x8H	<	8	H	h	x									
x9H	>	9	I	i	y									
xAH	*	:	J	j	z									
xBH	+	;	K	k	ç									
xCH	,	<	L	l	ö									
xDH	-	=	M	m	ö									
xEH	.	>	N	n	ö									
xFH	/	?	O	o										

14.3.5.6 International Font set. 1Bh 52h n	14.3.5.7 Character Table type 1Bh 74h n
---	--

For font pattern details, refer to 11 Character Fonts specification, page 16.

11 Character Fonts specification

11.1 Common Font Set (20h – 7Fh)

This font set is selected after initial turn on, and its character codes are based on ASCII codes. Most characters are displayed in a 5x7 Matrix font, but the five characters 'g', 'j', 'p', 'q' and 'y' are displayed in a 5x8 Matrix font which gives a more natural appearance, similar to printed text. Refer to 14.3.5.8 5x8 Matrix font, page 31.

	2	3	4	5	6	7
	x	x	x	x	x	x
	H	H	H	H	H	H
x0H		0	0	P	^	p
x1H	!	1	A	Q	a	q
x2H	"	2	B	R	b	r
x3H	#	3	C	S	c	s
x4H	\$	4	D	T	d	t
x5H	%	5	E	U	e	u
x6H	&	6	F	V	f	v
x7H	'	7	G	W	g	w
x8H	<	8	H	X	h	x
x9H	>	9	I	Y	i	y
xAH	*	:	J	Z	j	z
xBH	+	:	K	L	k	l
xCH	,	<	L	N	l	n
xDH	-	=	M	I	m	i
xEH	.	>	N	^	n	^
xFH	/	?	O	_	o	_

11.2 Alternative 5x7 Matrix font

The five characters 'g', 'j', 'p', 'q' and 'y' can also be displayed in Alternative 5x7 Matrix font instead of Common font.

Refer to 14.3.5.8 5x8 Matrix font, page 31.

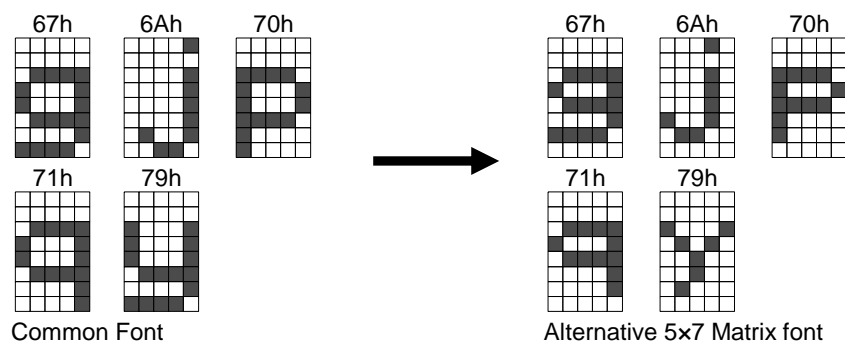

11.3 Alternative Magnified font (20h – 7Fh)

In 2x2 Font Magnification mode, the following 28 characters, such as '!', '1', '(, etc. can optionally be displayed in an Alternative Magnified font instead of the Common font.
Refer to 14.3.5.10 Alternative Magnified Font, page 31.

Details of Alternative Magnified font pattern

Character code	21h	27h	28h	29h	2Ch	2Dh
Alternative Magnified font Pattern						
Common font Pattern						

Character code	2Eh	31h	33h	34h	39h	3Ah
Alternative Magnified font Pattern						
Common font Pattern						

Character code	3Bh	3Dh	3Fh	47h	49h	4Ah
Alternative Magnified font Pattern						
Common font Pattern						

Character code	51h	52h	53h	59h	66h	69h
Alternative Magnified font Pattern						
Common font Pattern						

Character code	6Ch	74h	79h*	7Ch		
Alternative Magnified font Pattern						
Common font pattern						

* Alternative 5x7 Matrix font selected

11.4 International Font Set

One of the following international font sets is selected using the "International Font set" command (1Bh 52h n), and its characters replace the corresponding code characters in Common font set. Refer to 10 Font Table Configuration, page 15.

n	00H	01H	02H	03H	04H	05H	06H	07H	08H	09H	0AH	0BH	0CH	0DH
23H	#	#	#	E	#	#	#	R	#	#	#	#	#	#
24H	\$	\$	\$	\$	\$	\$	\$	\$	\$	\$	\$	\$	\$	\$
40H	à	á	â	ã	ä	å	æ	ç	è	é	ê	ë	ä	å
5BH	í	°	ñ	ê	ñ	°	í	í	í	í	í	í	í	í
5CH	\	ö	\	ö	\	ö	\	ö	\	ö	\	ö	\	ö
5DH	ı	ş	ı	ş	ı	ş	ı	ş	ı	ş	ı	ş	ı	ş
5EH	^	^	^	^	^	^	^	^	^	^	^	^	^	^
60H	\	\	\	\	\	\	\	\	\	\	\	\	\	\
7BH	ç	é	ä	ç	æ	ä	ç	æ	ä	ç	æ	ä	ç	æ
7CH	ı	ö	ı	ö	ı	ö	ı	ö	ı	ö	ı	ö	ı	ö
7DH	ö	é	ü	ö	ä	ä	ö	ö	ä	ä	ö	ö	ä	ä
7EH	ı	ı	ö	ı	ı	ı	ı	ı	ı	ı	ı	ı	ı	ı

11.5 Character Table Type (80h – FFh)

One of the following character table types is selected using the “Character Table type” command (1Bh 74h n), and the characters are added to Common Font set.

Refer to 14.3.5.7 Character Table type, page 30.

n = 00h

	8 x H	9 x H	A x H	B x H	C x H	D x H	E x H	F x H
x0H	0	1	2	3	4	5	6	7
x1H	8	9	A	B	C	D	E	F
x2H	G	H	I	J	K	L	M	N
x3H	O	P	Q	R	S	T	U	V
x4H	W	X	Y	Z	[\]	^
x5H	_	`	a	b	c	d	e	f
x6H	g	h	i	j	k	l	m	n
x7H	o	p	q	r	s	t	u	v
x8H	w	x	y	z	{		}	~
x9H								
xAH								
xBH		¡	¢	£	¤	¥	¦	§
xCH	¨	©	ª	«	¬	­	®	¯
xDH	°	±	²	³	´	µ	¶	·
xEH	¸	¹	º	»	¼	½	¾	¿
xFH								

n = 01h

	8 x H	9 x H	A x H	B x H	C x H	D x H	E x H	F x H
x0H	0	1	2	3	4	5	6	7
x1H	8	9	A	B	C	D	E	F
x2H	G	H	I	J	K	L	M	N
x3H	O	P	Q	R	S	T	U	V
x4H	W	X	Y	Z	[\]	^
x5H	_	`	a	b	c	d	e	f
x6H	g	h	i	j	k	l	m	n
x7H	o	p	q	r	s	t	u	v
x8H	w	x	y	z	{		}	~
x9H								
xAH								
xBH		¡	¢	£	¤	¥	¦	§
xCH	¨	©	ª	«	¬	­	®	¯
xDH	°	±	²	³	´	µ	¶	·
xEH	¸	¹	º	»	¼	½	¾	¿
xFH								

n = 02h

	8 x H	9 x H	A x H	B x H	C x H	D x H	E x H	F x H
x0H	0	1	2	3	4	5	6	7
x1H	8	9	A	B	C	D	E	F
x2H	G	H	I	J	K	L	M	N
x3H	O	P	Q	R	S	T	U	V
x4H	W	X	Y	Z	[\]	^
x5H	_	`	a	b	c	d	e	f
x6H	g	h	i	j	k	l	m	n
x7H	o	p	q	r	s	t	u	v
x8H	w	x	y	z	{		}	~
x9H								
xAH								
xBH		¡	¢	£	¤	¥	¦	§
xCH	¨	©	ª	«	¬	­	®	¯
xDH	°	±	²	³	´	µ	¶	·
xEH	¸	¹	º	»	¼	½	¾	¿
xFH								

n = 03h

	8 x H	9 x H	A x H	B x H	C x H	D x H	E x H	F x H
x0H	0	1	2	3	4	5	6	7
x1H	8	9	A	B	C	D	E	F
x2H	G	H	I	J	K	L	M	N
x3H	O	P	Q	R	S	T	U	V
x4H	W	X	Y	Z	[\]	^
x5H	_	`	a	b	c	d	e	f
x6H	g	h	i	j	k	l	m	n
x7H	o	p	q	r	s	t	u	v
x8H	w	x	y	z	{		}	~
x9H								
xAH								
xBH		¡	¢	£	¤	¥	¦	§
xCH	¨	©	ª	«	¬	­	®	¯
xDH	°	±	²	³	´	µ	¶	·
xEH	¸	¹	º	»	¼	½	¾	¿
xFH								

n = 04h

	8xH	9xH	AxH	BxH	CxH	DxH	ExH	FxH
x0H	0	1	2	3	4	5	6	7
x1H	8	9	A	B	C	D	E	F
x2H	10	11	12	13	14	15	16	17
x3H	18	19	1A	1B	1C	1D	1E	1F
x4H	20	21	22	23	24	25	26	27
x5H	28	29	2A	2B	2C	2D	2E	2F
x6H	30	31	32	33	34	35	36	37
x7H	38	39	3A	3B	3C	3D	3E	3F
x8H	40	41	42	43	44	45	46	47
x9H	48	49	4A	4B	4C	4D	4E	4F
xAH	50	51	52	53	54	55	56	57
xBH	58	59	5A	5B	5C	5D	5E	5F
xCH	60	61	62	63	64	65	66	67
xDH	68	69	6A	6B	6C	6D	6E	6F
xEH	70	71	72	73	74	75	76	77
xFH	78	79	7A	7B	7C	7D	7E	7F

n = 05h

	8xH	9xH	AxH	BxH	CxH	DxH	ExH	FxH
x0H	0	1	2	3	4	5	6	7
x1H	8	9	A	B	C	D	E	F
x2H	10	11	12	13	14	15	16	17
x3H	18	19	1A	1B	1C	1D	1E	1F
x4H	20	21	22	23	24	25	26	27
x5H	28	29	2A	2B	2C	2D	2E	2F
x6H	30	31	32	33	34	35	36	37
x7H	38	39	3A	3B	3C	3D	3E	3F
x8H	40	41	42	43	44	45	46	47
x9H	48	49	4A	4B	4C	4D	4E	4F
xAH	50	51	52	53	54	55	56	57
xBH	58	59	5A	5B	5C	5D	5E	5F
xCH	60	61	62	63	64	65	66	67
xDH	68	69	6A	6B	6C	6D	6E	6F
xEH	70	71	72	73	74	75	76	77
xFH	78	79	7A	7B	7C	7D	7E	7F

n = 10h

	8xH	9xH	AxH	BxH	CxH	DxH	ExH	FxH
x0H	0	1	2	3	4	5	6	7
x1H	8	9	A	B	C	D	E	F
x2H	10	11	12	13	14	15	16	17
x3H	18	19	1A	1B	1C	1D	1E	1F
x4H	20	21	22	23	24	25	26	27
x5H	28	29	2A	2B	2C	2D	2E	2F
x6H	30	31	32	33	34	35	36	37
x7H	38	39	3A	3B	3C	3D	3E	3F
x8H	40	41	42	43	44	45	46	47
x9H	48	49	4A	4B	4C	4D	4E	4F
xAH	50	51	52	53	54	55	56	57
xBH	58	59	5A	5B	5C	5D	5E	5F
xCH	60	61	62	63	64	65	66	67
xDH	68	69	6A	6B	6C	6D	6E	6F
xEH	70	71	72	73	74	75	76	77
xFH	78	79	7A	7B	7C	7D	7E	7F

n = 11h

	8xH	9xH	AxH	BxH	CxH	DxH	ExH	FxH
x0H	0	1	2	3	4	5	6	7
x1H	8	9	A	B	C	D	E	F
x2H	10	11	12	13	14	15	16	17
x3H	18	19	1A	1B	1C	1D	1E	1F
x4H	20	21	22	23	24	25	26	27
x5H	28	29	2A	2B	2C	2D	2E	2F
x6H	30	31	32	33	34	35	36	37
x7H	38	39	3A	3B	3C	3D	3E	3F
x8H	40	41	42	43	44	45	46	47
x9H	48	49	4A	4B	4C	4D	4E	4F
xAH	50	51	52	53	54	55	56	57
xBH	58	59	5A	5B	5C	5D	5E	5F
xCH	60	61	62	63	64	65	66	67
xDH	68	69	6A	6B	6C	6D	6E	6F
xEH	70	71	72	73	74	75	76	77
xFH	78	79	7A	7B	7C	7D	7E	7F

n = 12h

	8 x H	9 x H	A x H	B x H	C x H	D x H	E x H	F x H
x0H	☐	☐	☐	☐	☐	☐	☐	-
x1H	☐	☐	☐	☐	☐	☐	☐	☐
x2H	☐	☐	☐	☐	☐	☐	☐	☐
x3H	☐	☐	☐	☐	☐	☐	☐	☐
x4H	☐	☐	☐	☐	☐	☐	☐	☐
x5H	☐	☐	☐	☐	☐	☐	☐	☐
x6H	☐	☐	☐	☐	☐	☐	☐	☐
x7H	☐	☐	☐	☐	☐	☐	☐	☐
x8H	☐	☐	☐	☐	☐	☐	☐	☐
x9H	☐	☐	☐	☐	☐	☐	☐	☐
xAH	☐	☐	☐	☐	☐	☐	☐	☐
xBH	☐	☐	☐	☐	☐	☐	☐	☐
xCH	☐	☐	☐	☐	☐	☐	☐	☐
xDH	☐	☐	☐	☐	☐	☐	☐	☐
xEH	☐	☐	☐	☐	☐	☐	☐	☐
xFH	☐	☐	☐	☐	☐	☐	☐	☐

n = 13h

	8 x H	9 x H	A x H	B x H	C x H	D x H	E x H	F x H
x0H	☐	☐	☐	☐	☐	☐	☐	-
x1H	☐	☐	☐	☐	☐	☐	☐	☐
x2H	☐	☐	☐	☐	☐	☐	☐	☐
x3H	☐	☐	☐	☐	☐	☐	☐	☐
x4H	☐	☐	☐	☐	☐	☐	☐	☐
x5H	☐	☐	☐	☐	☐	☐	☐	☐
x6H	☐	☐	☐	☐	☐	☐	☐	☐
x7H	☐	☐	☐	☐	☐	☐	☐	☐
x8H	☐	☐	☐	☐	☐	☐	☐	☐
x9H	☐	☐	☐	☐	☐	☐	☐	☐
xAH	☐	☐	☐	☐	☐	☐	☐	☐
xBH	☐	☐	☐	☐	☐	☐	☐	☐
xCH	☐	☐	☐	☐	☐	☐	☐	☐
xDH	☐	☐	☐	☐	☐	☐	☐	☐
xEH	☐	☐	☐	☐	☐	☐	☐	☐
xFH	☐	☐	☐	☐	☐	☐	☐	☐

12 Display Area End-of-Line Behavior

In most cases, the cursor moves to the right by one character after a character is displayed at the current cursor position. However, at end of line, the behavior depends on the current cursor position, the currently-selected character size, and the display mode. Some examples follow:

Regular size (1x1) characters (Over-write mode)

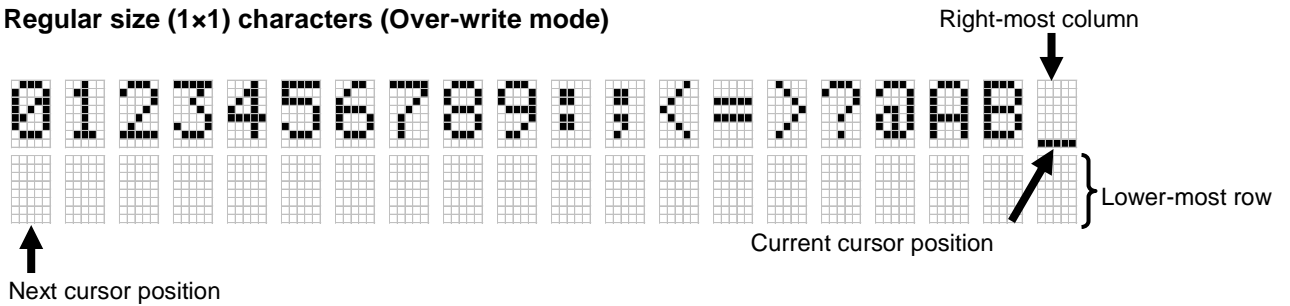

1x2 Magnified characters (Over-write mode)

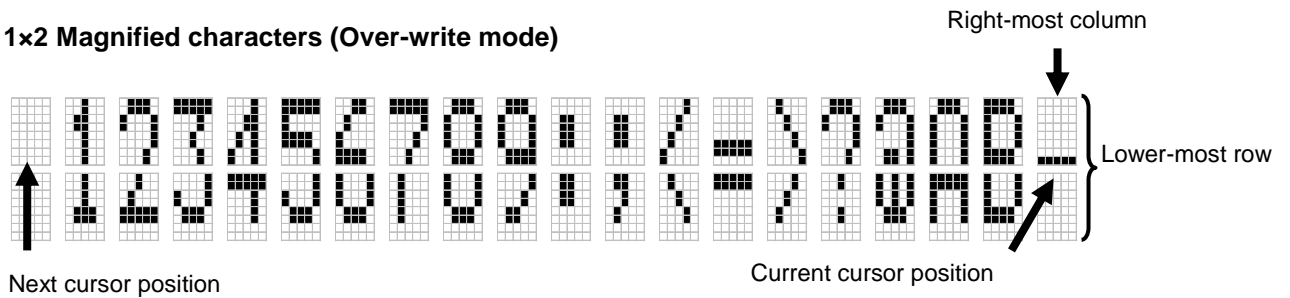

2x2 Magnified characters (Over-write mode)

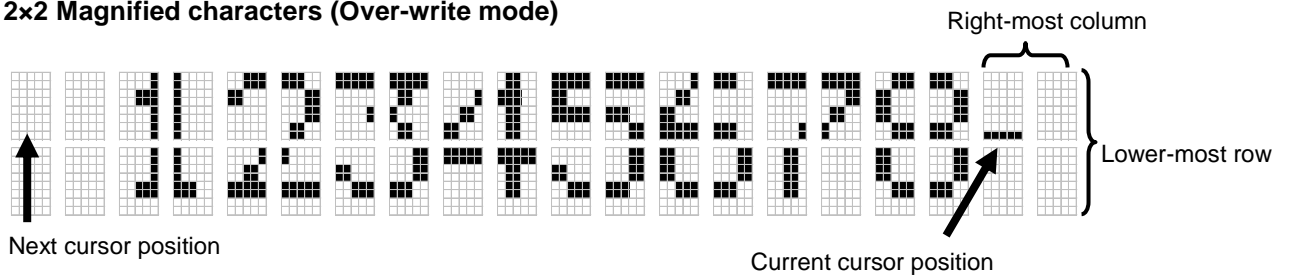

2x2 Magnified characters (Over-write mode)

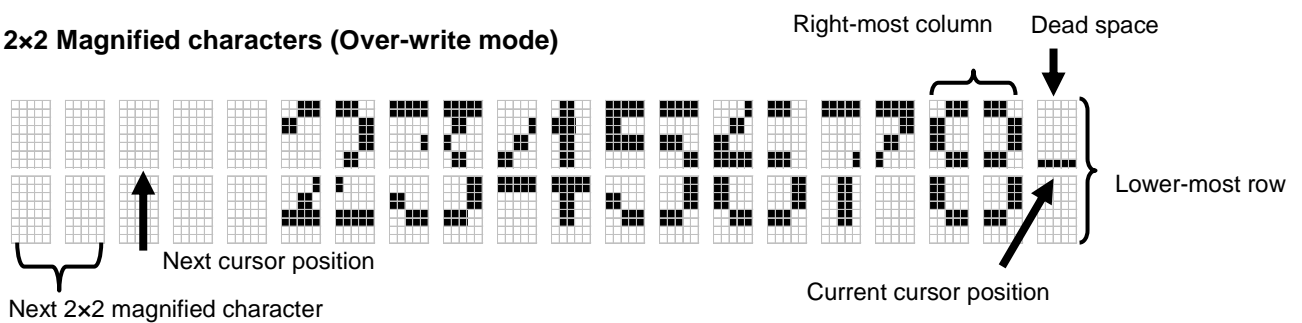

Note: Dead space in the above situation is cleared. It is possible to display a regular-width character (1x1 or 1x2) in the dead space.

13 Initial settings

Initial states are set as follows.

	Power on	"Initialize display" command	External reset or "Reset" command	"User set up mode end" command
Cursor position	Home position			
RAM user font	Disabled			
Cursor display	Underline cursor			
Display mode	Over-write mode			
Write mode	Quick write mode			
International font set	America			
Character Table type	PC437(USA – Euro std)			
Blink	OFF			
Underline	OFF			
Brightness (character)	Level 8 (100%)			
Brightness (screen)	100%			
Blink speed	40h			
Horizontal scroll speed	Instantaneous (n=00h)			
RAM User font data	Cleared			
Blink display action (at c=00h)	–	Stopped		
5x8 Matrix font	ON (5x8 Matrix font)			
Alternative Magnified Font	OFF (Normal font)			
Font Magnification	x=1, y=1			
Baud rate (J0, J1)	Re-loaded	Not re-loaded	Re-loaded	Re-loaded
Serial interface (J2)	Re-loaded	Not re-loaded	Re-loaded	Re-loaded
Test mode (JT)	Re-loaded	Not re-loaded	Re-loaded	Re-loaded

14 Commands

This display's commands are arranged as follows.

14.1 Command Configuration

08h–16h	Control command
1Bh ...	ESC command
1Fh ...	User Setup command
– 1Fh 28h 61h ...	– Action command
– 1Fh 28h 65h ...	– Operation mode-related command
– 1Fh 28h 67h ...	– Character-related command
20h–FFh	Character code

14.2 Command Set

Command Name	Hex Code				
	BYTE1	BYTE2	BYTE3	BYTE4	Parameter
Back Space	08h	–	–	–	–
Horizontal Tab	09h	–	–	–	–
Line Feed	0Ah	–	–	–	–
Home Position	0Bh	–	–	–	–
Display Clear	0Ch	–	–	–	–
Carriage Return	0Dh	–	–	–	–
Cursor Underline	13h	–	–	–	–
Cursor Off	14h	–	–	–	–
Cursor Block	15h	–	–	–	–
Cursor Underline Blink	16h	–	–	–	–
RAM user font	1Bh	25h	–	–	n
RAM user font Define		26h	01h	–	c1 c2 [x1 d1...d(a x x1)]... [xk d1...d(a x xk)]
RAM user font Delete		3Fh	01h	–	c
Initialize display		40h	–	–	–
Blink OFF		41h	–	–	–
Blink ON		42h	–	–	–
Write Mode – Quick		45h	–	–	–
International font set		52h	–	–	n
Write Mode – Flickerless		53h	–	–	–
Blink speed		54h	–	–	s
Underline ON		55h	–	–	–
Underline OFF		57h	–	–	–
Character Insert		58h	F3h	–	–
Character Delete			F4h	–	–
Line Insert			F5h	–	–
Line Delete			F6h	–	–
Reset			FFh	–	–
Character Table type	74h	–	–	n	
Over-write mode	1Fh	01h	–	–	
Vertical scroll mode		02h	–	–	–
Horizontal scroll mode		03h	–	–	–
Cursor set		24h	–	–	xL 00h yL 00h
Wait		61h	01h	t	
Blink (screen)			11h	p t1 t2 c	
Screen saver			40h	p	
User set up mode start		28h	01h	d1 d2	
User set up mode end			02h	d1 d2 d3	
FROM user font Define			14h	P(20h-1) P(20h-2)...P(FFh-5)	
Diagnostic Status information Read			40h	a [b c d e]	
Status information Display			41h	a	
Diagnostic Serial OUT mode start			83h	d1 d2	
Diagnostic Serial OUT mode end			84h	d1 d2 d3	
5x8 Matrix font			67h	04h	d
Alternative Magnified Font		06h		s	
Font Magnification		40h		x y	
Brightness (character)	50h	d1 d2 d3			
Brightness (screen)	58h	–	n		
Horizontal scroll speed	73h	–	n		
Character display	20–FFh	–	–	–	

14.3 Detail of Command Set

14.3.1 Character display

Code: 20h – FFh

Note: Refer also to “12 Display Area End-of-Line Behavior”, page 22.

Function: Display a character on the current cursor position. The details of operation are as follows:

Over-write mode

Cursor position		Operation
X(column)	Y(row)	
Not right-most column	-	Display character at cursor position. Cursor moves to the right by one character.
Right-most column	Not lower-most row	Display character at cursor position. Cursor moves to left end of next lower row.
	Lower-most row	Display character at cursor position. Cursor moves to the home position (left end, top row)

Vertical scroll mode

Cursor position		Operation
X(column)	Y(row)	
Not right-most column	-	Display character at cursor position. Cursor moves to the right by one character.
Right-most column	Not lower-most row	Display character at cursor position. Cursor moves to left-most column, next lower row.
	Lower-most row	Display character at cursor position. Display contents shift up by one line, lower-most row is cleared. Cursor moves to left end of lower-most row.

Horizontal scroll mode

Cursor position		Operation
X(column)	Y(row)	
Not right-most column	-	Display character at cursor position. Cursor moves to the right by one character.
Right-most column	-	Display character at cursor position. Transition to Scroll ON mode. Note: Cursor does not move.

	Operation
Scroll ON mode	Current line display contents shift left by one column. Display character at cursor position. Note: Cursor does not move.

Note: Scroll ON mode is cancelled if any of the following commands are executed: “Back Space”, “Line Feed”, “Home Position”, “Display Clear”, “Carriage Return”, “Cursor Set”, “Over-write mode”, “Vertical scroll mode”, “Horizontal scroll mode”, “Insert character”, “Delete character”, “Insert line” and “Delete line”.

14.3.2 Standard Ascii control codes

14.3.2.1 Back Space

Code: 08h

Note: Refer also to “12 Display Area End-of-Line Behavior”, page 22.

Function: The cursor moves to the left by one character. The details of operation are as follows:

Over-write mode or Vertical scroll mode

Cursor position		Operation
X(column)	Y(row)	
Not left-most column	-	Cursor moves to the left by one character.
Left-most column	Not upper-most row	Cursor moves to right-most column of next upper row.
	Upper-most row	No operation

Horizontal scroll mode

Cursor position		Operation
X(column)	Y(row)	
Not left-most column	-	Cursor moves to the left by one character.
Left-most column	-	No operation

14.3.2.2 Horizontal Tab

Code: 09h

Note: Refer also to “12 Display Area End-of-Line Behavior”, page 22.

Function: The cursor moves to the right by one character. The details of operation are as follows:

Over-write mode

Cursor position		Operation
X(column)	Y(row)	
Not right-most column	-	Cursor moves to the right by one character.
Right-most column	Not lower-most row	Cursor moves to left end of next lower row.
	Lower-most row	Cursor moves to the home position (left end, top row).

Vertical scroll mode

Cursor position		Operation
X(column)	Y(row)	
Not right-most column	-	Cursor moves to the right by one character.
Right-most column	Not lower-most row	Cursor moves to left end of next lower row.
	Lower-most row	Display contents shift up by one line, lower-most row is cleared. Cursor moves to left end of lower-most row.

Horizontal scroll mode

Cursor position		Operation
X(column)	Y(row)	
Not right-most column	-	Cursor moves to the right by one character.
Right-most column	-	Current line display contents shift left by one character and display is cleared at cursor position. Transition to (or remain in) Scroll ON mode. Note: Cursor does not move.

Note: Scroll ON mode is cancelled if any of the following commands are executed: “Back Space”, “Line Feed”, “Home Position”, “Display Clear”, “Carriage Return”, “Cursor Set”, “Over-write mode”, “Vertical scroll mode”, “Horizontal scroll mode”, “Insert character”, “Delete character”, “Insert line” and “Delete line”.

14.3.2.3 Line Feed

Code: 0Ah

Note: Refer also to “12 Display Area End-of-Line Behavior”, page 22.

Function: The cursor moves to next lower line. The details of operation are as follows:

Over-write mode

Cursor position		Operation
X(column)	Y(row)	
-	Not lower-most row	Cursor moves to next lower row (same column).
	Lower-most row	Cursor moves to the home position (left end, top row).

Vertical scroll mode

Cursor position		Operation
X(column)	Y(row)	
-	Not lower-most row	Cursor moves to next lower row (same column).
	Lower-most row	Display contents shift up by one line, lower-most row is cleared. Note: Cursor does not move.

Horizontal scroll mode

Cursor position		Operation
X(column)	Y(row)	
-	-	No operation

14.3.2.4 Home Position

Code: 0Bh

Function: Cursor moves to the home position (left end of top line).

14.3.2.5 Display Clear

Code: 0Ch

Function: Display is cleared and cursor moves to home position.

14.3.2.6 Carriage Return

Code: 0Dh

Function: Cursor moves to left end of same line.

14.3.3 Insert/Delete commands

14.3.3.1 Character Insert

Code: 1Bh 58h F3h

Function: Characters from cursor position to right end of same line move to the right by one character. The right-most character is discarded. One-character blank (space) is set at cursor position. Cursor does not move.

Command is ignored if there is insufficient space in the x and/or y direction for one character at the current cursor position.

14.3.3.2 Character Delete

Code: 1Bh 58h F4h

Function: Character at cursor position is deleted, and display from there to right end of same line moves to the left by one character. One-character blank (space) is set at right end of same line. Cursor does not move.

Command is ignored if there is insufficient space in the x and/or y direction for one character at the current cursor position.

14.3.3.3 Line Insert

Code: 1Bh 58h F5h

Function: Display contents for the line of the current cursor position, and all lower lines, are shifted down by one line. The line of the current cursor position is blanked (space), and cursor position is set to left end of same line. Display contents in the bottom line are discarded. Command is ignored if there is insufficient space in the x and/or y direction for one character at the current cursor position.

14.3.3.4 Line Delete

Code: 1Bh 58h F6h

Function: The line of the current cursor position is deleted, and the below display is moved up by one line. Cursor position does not change. Bottom line is blanked (space). Command is ignored if there is insufficient space in the x and/or y direction for one character at the current cursor position.

14.3.4 Cursor commands

14.3.4.1 Cursor set

Code: 1Fh 24h xL 00h yL 00h

xL: Cursor position x Lower byte (1 char / unit)

yL: Cursor position y Lower byte (1 line / unit)

Definable area: $0 (00h) \leq xL \leq 19 (13h)$

$0 (00h) \leq yL \leq 1 (01h)$

Function: The cursor moves to the specified X, Y position. If the specified X, Y position (X, Y, either or both) is outside the definable area, the command is ignored, and the cursor remains in the same position.

		x:					
		00h	01h	---	12h	13h	
y:	00h	□□□□ □□□□ □□□□ □□□□ □□□□ □□□□ □□□□ □□□□	□□□□ □□□□ □□□□ □□□□ □□□□ □□□□ □□□□ □□□□	---		□□□□ □□□□ □□□□ □□□□ □□□□ □□□□ □□□□ □□□□	□□□□ □□□□ □□□□ □□□□ □□□□ □□□□ □□□□ □□□□
	01h	□□□□ □□□□ □□□□ □□□□ □□□□ □□□□ □□□□ □□□□	□□□□ □□□□ □□□□ □□□□ □□□□ □□□□ □□□□ □□□□	---		□□□□ □□□□ □□□□ □□□□ □□□□ □□□□ □□□□ □□□□	□□□□ □□□□ □□□□ □□□□ □□□□ □□□□ □□□□ □□□□

14.3.4.2 Cursor Underline

Code: 13h

Function: Cursor is displayed as underline.

14.3.4.3 Cursor Underline Blink

Code: 16h

Function: Cursor is displayed as underline, blinking.
Blinking speed can be varied by 14.3.7.3 Blink speed.

14.3.4.4 Cursor Block

Code: 15h

Function: Cursor is displayed as a block, blinking.
Blinking speed can be varied by 14.3.7.3 Blink speed.

14.3.4.5 Cursor Off

Code: 14h

Function: Cursor display is OFF.

14.3.5 Character format commands

14.3.5.1 Underline ON

Code: 1Bh 55h

Function: Specifies underline display mode.

Characters written after this command are displayed with underline. Characters already displayed are not affected.

Note: The underline changes the appearance of characters. Refer to the following examples.

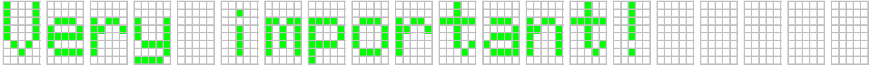
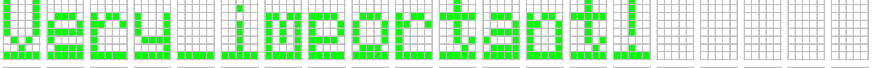
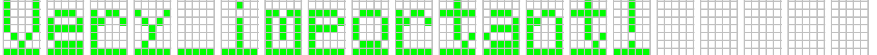
5×8 font without underline	
5×8 font with underline	
5×7 font with underline	

14.3.5.2 Underline OFF

Code: 1Bh 57h

Function: Cancel underline display mode.

Characters written after this command are displayed with no underline.

Characters already displayed are not affected.

14.3.5.3 Blink ON

Code: 1Bh 42h

Function: Specifies character blink mode.

Blinking starts for characters written after this command is executed.

Characters already displayed are not affected.

Blinking speed can be varied by 14.3.7.3 Blink speed.

14.3.5.4 Blink OFF

Code: 1Bh 41h

Function: Cancel character blink mode.

Blinking stops for characters written after this command is executed.

Characters already displayed are not affected.

14.3.5.5 Brightness (character)

Code: 1Fh 28h 67h 50h d1 d2 d3

d1: Gray-shade level

d2: Reserved

d3: Reserved

Definable area: 1 (01h) ≤ d1 ≤ 8 (08h), 49 (31h) ≤ d1 ≤ 54 (38h)

d1	Level
01h or 31h	Level 1 (0%)
02h or 32h	Level 2 (14%)
03h or 33h	Level 3 (29%)
04h or 34h	Level 4 (43%)
05h or 35h	Level 5 (57%)
06h or 36h	Level 6 (71%)
07h or 37h	Level 7 (86%)
08h or 38h	Level 8 (100%)

0 (00h) ≤ d2 ≤ 255 (FFh)

0 (00h) ≤ d3 ≤ 255 (FFh)

Default: d1 = 8 (08h)

Function: Specify gray-shade level of characters.

This setting is effective for characters written after this command is executed. Characters already displayed are not affected.

Note: The character brightness is relative to the screen brightness. If the screen brightness level and the character brightness level are 200% and Level 5 (57%) respectively, the actual brightness of the character is 200% × 57% = 114%. To set the screen brightness, refer to 14.3.7.1 Brightness (screen), page 33.

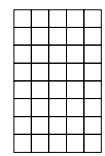
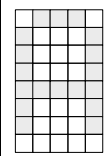
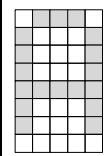
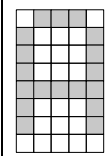
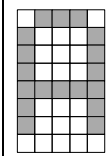
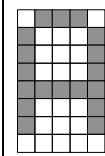
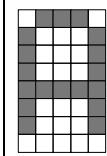
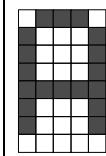
Level 1 (0%)	Level 2 (14%)	Level 3 (29%)	Level 4 (43%)	Level 5 (57%)	Level 6 (71%)	Level 7 (86%)	Level 8 (100%)
							

14.3.5.6 International Font set

Code: 1Bh 52h n

Definable area: 0 (00h) ≤ n ≤ 13 (0Dh)

Default: n = 0 (00h)

Function: Select international font set.

Characters already displayed are not affected.

Note: Refer to 10 Font Table Configuration, page 15.

n	Font set
00h	America
01h	France
02h	Germany
03h	England
04h	Denmark 1
05h	Sweden
06h	Italy
07h	Spain1
08h	Japan
09h	Norway
0Ah	Denmark2
0Bh	Spain2
0Ch	Latin America
0Dh	Korea

14.3.5.7 Character Table type

Code: 1Bh 74h n

Definable area: n = 0 (00h), 1 (01h), 2 (02h), 3 (03h), 4 (04h),
5 (05h), 16 (10h), 17 (11h), 18 (12h),
19 (13h), 255 (FFh)

Default: n = 0 (00h)

Function: Selects font code

Characters already displayed are not affected.

Note: Refer to 10 Font Table Configuration, page 15.

n	Font code type
00h	PC437(USA – Euro std)
01h	Katakana – Japanese
02h	PC850 (Multilingual)
03h	PC860 (Portuguese)
04h	PC863 (Canadian-French)
05h	PC865 (Nordic)
10h	WPC1252
11h	PC866 (Cyrillic #2)
12h	PC852 (Latin 2)
13h	PC858
FFh	FROM User font table

14.3.5.8 5x8 Matrix font

Code: 1Fh 28h 67h 04h d

d: Select / Deselect 5x8 Matrix font

Definable area: 128 (80h) ≤ d ≤ 129 (81h)

d = 80h: Deselect 5x8 Matrix font

d = 81h: Select 5x8 Matrix font

Default: d = 81h (Select 5x8 Matrix font)

Function: Select / Deselect 5x8 Matrix font

Selecting 5x8 Matrix font gives descender to only these five characters: 'g' (67h), 'j' (6Ah), 'p' (70h), 'q' (71h) and 'y' (79h).

Both 5x8 font and 5x7 font give the same style fonts to the other characters.

d=81h: The five characters are displayed in 5x8 font after this command.

Characters already displayed are not affected.

For details of each pattern, refer to 11 Character Fonts specification, page 16.

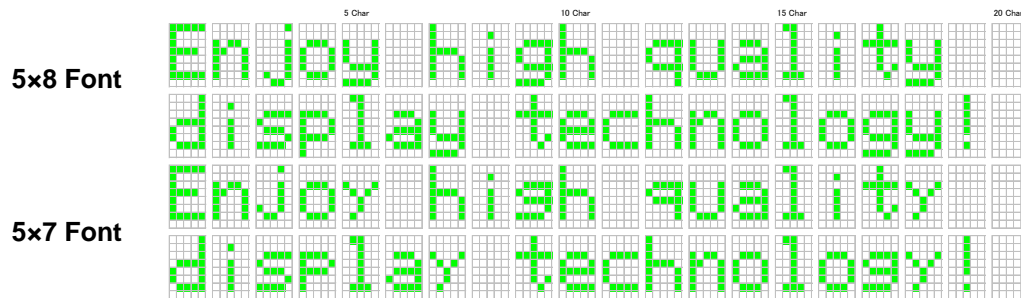

14.3.5.9 Font Magnification

Code: 1Fh 28h 67h 40h x y

x: Specify the size of magnification X

y: Specify the size of magnification Y

Definable area: 1 (01h) ≤ x ≤ 2 (02h)

1 (01h) ≤ y ≤ 2 (02h)

Default: x = 01h

y = 01h

Function: Magnify the character by x times on the right, y times downward.

This setting is effective for characters written after this command is executed.

Characters already displayed are not affected.

x=2, y=1 is not supported (command will be ignored).

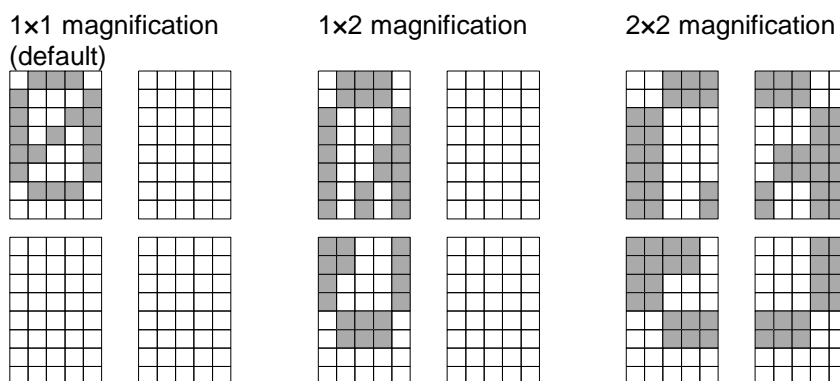

14.3.5.10 Alternative Magnified Font

Code: 1Fh 28h 67h 06h s

s: Select/Deselect Alternative Magnified Font

Definable area: 0 (00h) ≤ s ≤ 1 (01h)

s = 00h: Normal font

s = 01h: Alternative Magnified font

Default: s = 0 (00h)

Function: Select Alternative Magnified font to improve legibility for Font magnified display.

This setting is effective for characters written after this command is executed. Characters already displayed are not affected.

Alternative Magnified font is only used when magnification is $x=2x$, $y=2x$. At all other times, normal font is used regardless of this setting.

Applicable characters are only for International font set "America" ($n=00h$). For all other fonts, normal font is used regardless of this setting.

When FROM user font table ("Character Table type" command) is selected, user font characters have priority, regardless of this setting.

Note: For details of each pattern, refer to 11 Character Fonts specification, page 16.

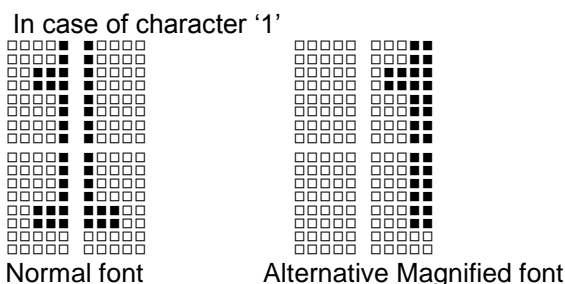

14.3.6 Custom font commands

This section describes the RAM user font. For FROM user font, refer to 14.3.9.2 FROM user font Define, page 36.

14.3.6.1 RAM user font

Code: 1Bh 25h n

Function: Enable or disable for RAM user font.

n = 01h, 31h: Enable (If RAM user font is not defined for a character code, built-in character is displayed)

n = 00h, 30h: Disable (RAM user font already defined are not affected)

Initial value: n = 00h

Characters already displayed are not affected.

When RAM user font is enabled ($n=01h$, $31h$), RAM user font is used for character codes defined using "RAM user font Define" command, regardless of the state of various other settings.

14.3.6.2 RAM user font Define

Code: 1Bh 26h a c1 c2 [x1 d1...d(axx1)]...[xk d1...d(axxk)]

a: Select character type

c1: Start character code

c2: End character code

x: Number of dot for X direction

d: Defined data

Definable area: a = 1 (01h)
 $32 (20h) \leq c1 \leq c2 \leq 255 (FFh)$
 $x = 5 (05h)$
 $0 (00h) \leq d \leq 255 (FFh)$
 $k = c2 - c1 + 1$

Function: Define user font into RAM.

A maximum of 16 characters may be defined.

After the first 16 are defined, any additional user font characters required must replace one already defined.

To display RAM user font characters, execution of "RAM user font Define" and "RAM user font" (enable) command is required. If a RAM user font character that is currently being displayed is re-defined, the currently-displayed character also changes to the new RAM user font character.

RAM User font data format 5x8 dot assignment

P1	P2	P3	P4	P5
P6	P7	P8	P9	P10
P11	P12	P13	P14	P15
P16	P17	P18	P19	P20
P21	P22	P23	P24	P25
P26	P27	P28	P29	P30
P31	P32	P33	P34	P35
P36	P37	P38	P39	P40

	B7(MSB)	B6	B5	B4	B3	B2	B1	B0(LSB)
1st byte	P8	P7	P6	P5	P4	P3	P2	P1
2nd byte	P16	P15	P14	P13	P12	P11	P10	P9
3rd byte	P24	P23	P22	P21	P20	P19	P18	P17
4th byte	P32	P31	P30	P29	P28	P27	P26	P25
5th byte	P40	P39	P38	P37	P36	P35	P34	P33

14.3.6.3 RAM user font Delete**Code: 1Bh 3Fh a c**

a: Select character

c: Character code to delete

Definable area: a = 1 (01h)
 32 (20h) ≤ c ≤ 255 (FFh)

Function: Delete defined RAM user font character.

The built-in character is displayed after this command is executed.

If the RAM user font character is currently being displayed, the display changes to built-in character (according to the current settings for "International Font set" and "Character Table type" commands).

This command is ignored if RAM user font is not defined for the character code.

14.3.7 Screen Action Commands**14.3.7.1 Brightness (screen)****Code: 1Fh 58h n**

n: Brightness level setting

Definable area: 1 (01h) ≤ n ≤ 8 (08h), 49 (31h) ≤ n ≤ 56 (38h)

Default: n = 4 (04h)

Function: Specify display brightness level.

n	Brightness level
01h or 31h	25 %
02h or 32h	50 %
03h or 33h	75 %
04h or 34h	100 %
05h or 35h	125 %
06h or 36h	150 %
07h or 37h	175 %
08h or 38h	200 %

14.3.7.2 Blink (screen)**Code: 1Fh 28h 61h 11h p t1 t2 c**

p: Blink pattern

t1: Normal display time

t2: Blank display time

c: Number of cycles

Definable area: 0 ≤ p ≤ 1

p=0: Display is not affected

p=1: Alternating normal and blank display

1 (01h) ≤ t1 ≤ 255 (FFh)

1 (01h) ≤ t2 ≤ 255 (FFh)

0 (00h) ≤ c ≤ 255 (FFh)

Function: Blink display action

Blink pattern specified by p.

Time specified by t1, t2, and repeat count by c.

A: t1×13.5 ms (Typ.) Normal display time

B: t2×13.5 ms (Typ.) Blank display time

This command does not affect the display memory.

If c=0 is specified, blinking continues during subsequent command/data processing, until c=1 – 255 or Initialize command is specified.

If c=1 – 255 is specified, blink display is repeated 1 – 255 times while command/data execution is stopped. After display blinking is completed, normal display and command/data execution is resumed.

During display blinking, Block cursor, Underline blink cursor, and Character blink stops.

After blink action, blinking speed for Block cursor, Underline blink cursor, and Character blink change to t1 and t2 as set in this command.

14.3.7.3 Blink speed

Code: 1Bh 54h s

s: Blinking speed

Definable area: 0 (00h) ≤ s ≤ 255 (FFh)
 00h, FFh: 128×13.5ms (Typ.)
 FEh, FDh: 127×13.5ms (Typ.)
 :
 :
 02h, 01h: 1×13.5ms (Typ.)

Default: s = 64 (40h) (32×13.5ms)

Function: Specifies blinking speed for Block cursor, Underline blink cursor, and character blink.

14.3.7.4 Wait

Code: 1Fh 28h 61h 01h t

t: Wait time

Definable area: 0 (00h) ≤ t ≤ 255 (FFh)

Function: Wait for the specified period of time. Command and data processing is suspended.

Wait time = t×0.5s approx.

14.3.7.5 Screen saver

Code: 1Fh 28h 61h 40h p

p: Screen saver mode

Definable area: 0 (00h) ≤ p ≤ 3 (03h), 48 (30h) ≤ p ≤ 51 (33h)
 p=00h or 30h: Power OFF (display OFF, Power save mode)
 p=01h or 31h: Power ON (display ON)
 p=02h or 32h: All dots OFF
 p=03h or 33h: All dots ON

Function: Control power ON or OFF, and start screen saver mode.

p=00h, 01h, 30h, 31h: Control power ON or OFF. Setting is effective until this command is re-specified, external reset, "Reset" command, or "User set up mode end" command.

p=02h, 03h, 32h, 33h: Start screen saver mode. When next command or data is received, screen saver is cancelled, and previous display condition is resumed.

All dots ON is at gray-shade level 8 (100%), regardless of the setting before Screen saver action.

14.3.8 Display Mode Commands

14.3.8.1 Over-write mode

Code: 1Fh 01h

Function: Display mode set to Over-write mode.

14.3.8.2 Vertical scroll mode

Code: 1Fh 02h

Function: Display mode set to Vertical scroll mode.

14.3.8.3 Horizontal scroll mode

Code: 1Fh 03h

Function: Display mode set to Horizontal scroll mode.

14.3.8.4 Horizontal scroll speed

Code: 1Fh 73h n

Definable area: 0 (00h) \leq n \leq 31 (1Fh)

Default: n = 0 (00h)

n	Scroll speed (time per character)
00h	Instantaneous
01h – 1Fh	n \times 13.5ms (Typ.)

Note: Next command is not executed until scrolling action is finished.

14.3.8.5 Write Mode - Quick

Code: 1Bh 45h

Function: Specifies quick write mode.

Quick data write with minimum BUSY time will be provided by this mode because data acceptance is given priority over refreshing of the screen.

Note: Within this mode, continuous high speed data write may cause display to flicker. Blinking speed may deviate from set speed.

The figure in 14.3.8.6 Write Mode - Flickerless shows the difference between Flickerless Mode and Quick Write Mode.

14.3.8.6 Write Mode - Flickerless

Code: 1Bh 53h

Function: Specifies flickerless write mode.

Within flickerless mode, although BUSY might become longer, flicker-less high-speed continuous data write can be achieved since refreshing of screen is given priority over data acceptance.

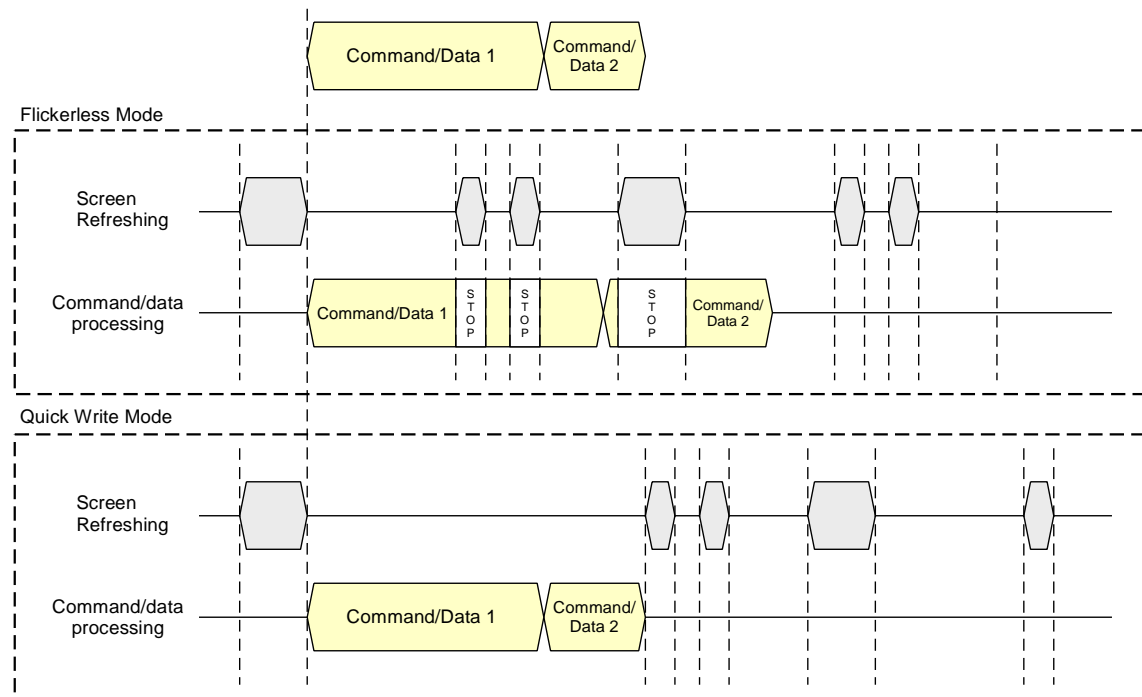

14.3.8.7 Initialize Display

Code: 1Bh 40h

Function: Clear display and return settings to initial state.
Software settings return to power-on state.
Jumper settings are not re-loaded.

14.3.8.8 Reset

Code: 1Bh 58h FFh

Function: Transition to state immediately after power-on.
Jumper settings are re-loaded – baud rate (for asynchronous serial), serial interface (synchronous / asynchronous) and test mode settings. Receive buffer is also cleared.

14.3.9 User setup mode Commands

14.3.9.1 User set up mode start

Code: 1Fh 28h 65h 01h 49h 4Eh

Definable area: d1 = 49h (Character 'I')
d2 = 4Eh (Character 'N')

Function: Start user set up mode.

This command is only valid in Direct Command mode.

Display screen is cleared and normal commands stop being accepted.

14.3.9.2 FROM user font Define

Code: 1Fh 28h 65h 14h P(20h-1) P(20h-2)...P(FFh-5)

P: Definition data

Definable area: 0 (00h) ≤ P ≤ 255 (FFh)

(20h-1)...P(20h-5)...P(FFh-5) 5 Bytes / font x224 characters (1120 bytes)

Function: Define the 1 byte user font to the user font table in FROM.

All 224 characters must be defined at once; it is not possible to only define some part of the FROM user font address space. Contents of FROM user font table are not defined when shipped.

This command is only valid in user setup mode.

Data defined by this command is retained even if power is turned off.
 Display power is switched OFF during processing of this command.
 The display screen is cleared and display power is turned on again after this command is executed.

To display FROM user font characters, "Character Table type" command (n=FFh) must be executed.

To define and display FROM user font characters:

- | | |
|--------------------------------------|--|
| (1) "User set up mode start" command | Code: 1Fh 28h 65h 01h 49h 4Eh |
| (2) "FROM user font Define" command | Code: 1Fh 28h 65h 14h P(20h-1) P(20h-2)...P(FFh-5) |
| (3) "User set up mode end" command | Code: 1Fh 28h 65h 02h 4Fh 55h 54h |
| (4) "Character Table type" command | Code: 1Bh 74h FFh |

FROM User font data format 5x8 dot assignment

P1	P2	P3	P4	P5
P6	P7	P8	P9	P10
P11	P12	P13	P14	P15
P16	P17	P18	P19	P20
P21	P22	P23	P24	P25
P26	P27	P28	P29	P30
P31	P32	P33	P34	P35
P36	P37	P38	P39	P40

	B7(MSB)	B6	B5	B4	B3	B2	B1	B0(LSB)
P(XXh-1)	P8	P7	P6	P5	P4	P3	P2	P1
P(XXh-2)	P16	P15	P14	P13	P12	P11	P10	P9
P(XXh-3)	P24	P23	P22	P21	P20	P19	P18	P17
P(XXh-4)	P32	P31	P30	P29	P28	P27	P26	P25
P(XXh-5)	P40	P39	P38	P37	P36	P35	P34	P33

14.3.9.3 Status information Display

Code: 1Fh 28h 65h 41h a

Definable area: a = 2 (02h), 32 (20h), 33 (21h)
 a = 02h: Firmware version
 a = 20h: Firmware checksum
 a = 30h: User font table checksum
 [P(20h-1)...P(FFh-5)]

Function: Display on home position the requested status information.

This command is only valid in user setup mode.

14.3.9.4 User set up mode end

Code: 1Fh 28h 65h 02h 4Fh 55h 54h

Definable area: d1 = 4Fh (Character 'O')
 d2 = 55h (Character 'U')
 d3 = 54h (Character 'T')

Function: End user set up mode, and software reset of display is executed.

This command is only valid in user setup mode.

After this command is executed, software reset is executed, the receiving buffer is cleared, and all settings and display are reset to a power-on condition.

Jumper settings are re-loaded – baud rate (for asynchronous serial), serial interface (synchronous / asynchronous) and test mode settings.

14.3.10 Diagnostic Serial OUT mode commands

Diagnostic Serial OUT mode can be used, if necessary, to read internal status information via the asynchronous serial interface. In this mode, the SBUSY pin functions as SOUT (transmission of response data). There is no flow control (handshaking) in this mode.

In order to avoid complications due to SBUSY changing function during operation, this mode is best used, if necessary, immediately after power-on.

14.3.10.1 Diagnostic Serial OUT mode start

Code: 1Fh 28h 65h 83h d1 d2

Definable area: d1 = 49h (Character 'I')
d2 = 4Eh (Character 'N')

Function: Switch SBUSY to Serial OUT and start "Diagnostic Serial OUT mode".

This command is only valid when Asynchronous serial interface is selected and mode is Direct Command mode.

Display screen is not changed and normal commands stop being accepted.

During Diagnostic Serial OUT mode, do not use SBUSY for communication flow control (SBUSY functions as SOUT in this mode).

14.3.10.2 Diagnostic Status information Read

Code: 1Fh 28h 65h 40h a [b c d e]

Definable area: a = 2 (02h), 32 (20h), 48 (30h), 128 (80h)

a = 02h: Firmware version information (b, c, d, e are not used)

a = 20h: Memory checksum information

0000h ≤ (b + cx100h) ≤ FFFFh: Start address

0000h ≤ (d + ex100h) ≤ FFFFh: Data length

a = 30h: Product type information (b, c, d, e are not used)

a = 80h: User font information (c, d, e are not used)

20h ≤ b ≤ FFh: Character code

Function: Respond with the requested display status information.

The following data are sent from the Asynchronous serial interface

This command is only valid in Diagnostic Serial OUT mode.

Response data	Hex	Data length
1: Header	28h	1 byte
2: Identifier 1	65h	1 byte
3: Identifier 2	40h	1 byte
4: Data	00h - FFh	a = 02h: 4 bytes a = 20h: 4 bytes a = 30h: 11 bytes a = 80h: 5 bytes

14.3.10.3 Diagnostic Serial OUT mode end

Code: 1Fh 28h 65h 84h d1 d2 d3

Definable area: d1 = 4Fh (Character 'O')
d2 = 55h (Character 'U')
d3 = 54h (Character 'T')

Function: Switch Serial OUT to SBUSY and start "Direct Command mode".

This command is only valid in Diagnostic Serial OUT mode.

After "Diagnostic Serial OUT mode end" command is executed, SBUSY=0 (READY) until receipt of next data.

15 Connectors

CN1 and CN3 are positioned as follows:

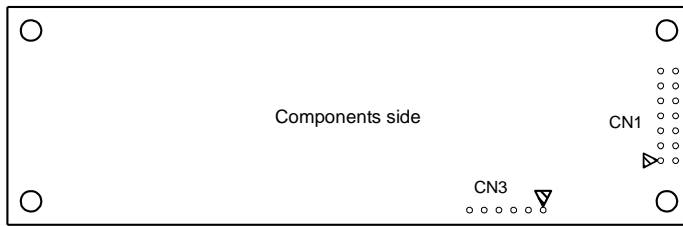

15.1 Parallel interface connector (Fourteen through-holes / CN1)

Pin No.	Signal name	Function	Direction	Pin No.	Signal name	Function	Direction
1	GND	Ground	-	8	D1	Data input	Input
2	VCC	Power supply	-	9	D2	Data input	Input
3	PBUSY	Display busy	Output	10	D3	Data input	Input
4	/RESET	Reset	Input	11	D4	Data input	Input
5	/WR	Data write	Input	12	D5	Data input	Input
6	NC	Not connected	-	13	D6	Data input	Input
7	D0	Data input (LSB)	Input	14	D7	Data input (MSB)	Input

15.2 Serial interface connector (Six through-holes / CN3)

15.2.1 If Asynchronous serial interface is selected.

Pin No.	Signal name	Function	Direction
1	VCC	Power supply	-
2	SIN	Data receive	Input
3	GND	Ground	-
4	SBUSY	Display busy	Output
5	NC	No connection	-
6	/RESET	Reset	Input

15.2.2 If Synchronous serial interface is selected.

Pin No.	Signal name	Function	Direction
1	VCC	Power supply	-
2	SIN	Data receive	Input
3	GND	Ground	-
4	SBUSY	Display busy	Output
5	SCK	Display clock	Input
6	/RESET	Reset	Input

16 Firmware Version Notation

The firmware version is shown in the following position.

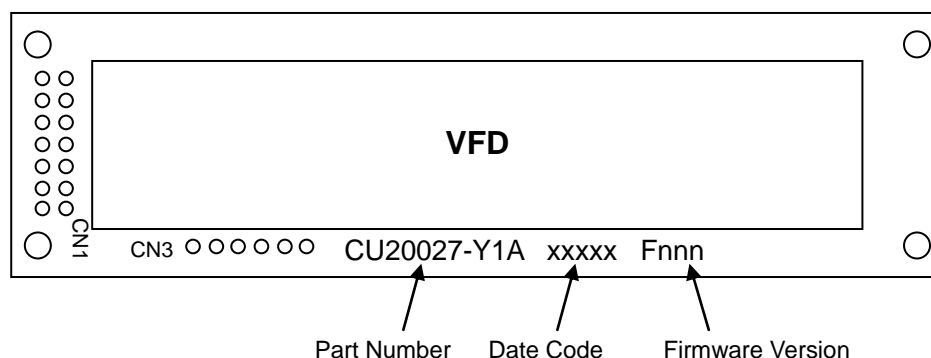

Notice for the Cautious Handling of VFD Modules

Handling and Usage Precautions:

Please carefully follow the appropriate product application notes and operation standards for proper usage, safe handling, and maximum performance.

[VFD tubes are made of glass]

- The edges of the VFD glass envelope are not smooth, so it is necessary to handle carefully to avoid injuries to hands.
- Use caution to avoid breaking the VFD glass envelope, to prevent injury from sharp glass particles.
- The tip of the exhaust pipe is fragile so avoid shock from impact.
- It is recommended to allow sufficient open space surrounding the exhaust pipe to avoid possible damage.
- Please design the PCB for the VFD module within 0.3 mm warping tolerance to avoid any forces that may damage the display due to PCB distortion causing a breakdown of the electrical circuit leading to VFD failure.

[High voltage]

- Avoid touching conductive electrical parts, because the VFD module uses high voltage exceeding 30 – 100 volts.
- Even when electric power is turned off, it may take more than one minute for the electrical current to discharge.

[Cable connection]

- Do not unplug the power and/or data cables of VFD modules during operation, because unrecoverable damage may result.
- Sending input signals to the VFD module when not powered can cause I/O port damage.
- It is recommended to use a 30cm or shorter signal cable to prevent functional failures.

[Electrostatic charge]

- VFD modules need electrostatic-free packaging and protection from electrostatic charges during handling and usage.

[Structure]

- During operation, VFD and VFD modules generate heat. Please consider sufficient heat radiation dissipation using heat sink solutions.
- Preferably, use UL-grade materials or components in conjunction with VFD modules.
- Warp and twist movement causes stress and may break VFDs and VFD modules. Please adhere to allowances within 0.3mm at the point of attachment.

[Power]

- Apply regulated power to the VFD module within specified voltages to protect from failures.
- VFD modules may draw in-rush current exceeding twice the typical current at power-on, so a power supply with sufficient capacity and quick starting of the power regulator is recommended.
- VFD module needs a specified voltage at the point of connection. Please use an adequate power cable to avoid a decrease in voltage. As a safety measure, a fuse or other over-current protection is recommended.

[Operating consideration]

- Illuminating phosphor will decrease in brightness during extended operation. If a fixed pattern illuminates for an extended period (several hours), the phosphor efficiency will decrease compared to the non-operating phosphor, causing non-uniform brightness. Please consider programming the display patterns to use all phosphor segments evenly. Scrolling may be a consideration for a period of time to refresh the phosphor condition and improve even illumination of the pixels.
- A signal cable 30cm or less is recommended to avoid possible disturbances to the signal.

[Storage and operating environment]

- Please use VFD modules under the recommended specified environmental conditions. Salty, sulfuric and dusty environments may damage the VFD module even during storage.

[Disposal]

- VFD uses lead-containing materials (RoHS directive exempts these lead compounds in the glass for electronic devices). When discarding VFDs or VFD modules, please adhere to applicable laws and regulations.

[Other cautions]

- Although the VFD module is designed to be protected from electrical noise, please plan your circuitry to exclude as much noise as possible.
- Do not reconstruct or repair the VFD module without our authorization. We cannot assure the quality or reliability of unauthorized reconstructed VFD modules.

Notice:

- We do not authorize the use of any patents that may be inherent in these specifications.
- Neither whole nor partial copying of these specifications is permitted without our approval. If necessary, please ask for assistance from our sales consultant.
- This product is not designed for military, aerospace, medical or other life-critical applications. If you choose to use this product for these applications, please ask us for prior consultation or we cannot accept responsibility for problems that may occur.

Revision history

Spec. number	Date	Revision
DS-1557-0001-00	Dec. 5, 2008	Initial Issue
DS-1557-0001-01	Dec. 17, 2008	13.3.1 Character display “Horizontal scroll mode” Operation has been corrected. 14.2 Serial interface connector Direction of SIN has been corrected.
DS-1557-0001-02	Feb. 19, 2010	Font specification included Command names simplified Order of command details re-arranged by function 14.3.10.1 Diagnostic Serial OUT mode start Correction: “Display screen is cleared”→“Display screen is not changed” 15 Connectors CN1 and CN3 position added. Minor spelling, grammar, and typographic corrections.