



CW3003 CW3004

Dual-Channel USB Charging Controller

Features

- D+/D- DCP Mode per USB Battery Charging Specification 1.2
- D+/D- Short Mode per Telecommunication Industry Standard YD/T1591-2009 (Chinese)
- Supports non-BC1.2 Charging Modes by Automatic Selection
 - D+/D- Option for Apple Device
 - D+/D- Option for Samsung Device
- Supports one Channel Applying 2.0V on D+ and 2.7V on D-, another Channel Applying 2.7V on both D+ and D- (CW3003)
- Supports Both Channels Applying 2.7V on both D+ and D- (CW3004)
- Operating Voltage Range: 4.5V to 5.5V
- Each Channel Power Consumption
 - 10uA When VDD<POR threshold
 - 360uA When VDD>POR threshold
- Lead(Pb)-Free, Halogen-Free, SOT23-6L Package
- 8kV HBM ESD Rating on DP/DM Pins

Applications

- Power bank
- USB Ports (Hosts and Hubs)
- MID OTG Port
- Wall Charging Adapters

Order Information

Name	Operation Temperature	Package	Parameter	Package Mark
CW3003AAAS	-30°C to 80°C	SOT23-6L	2.4A+1A	3003A
CW3004AAAS	-30°C to 80°C	SOT23-6L	2.4A+2.4A	3004A

General Description

CW3003 and CW3004 are the USB dedicated charging controller ICs, which are fully compatible with BC1.2 and other non-BC1.2 standards like YT/D1591-2009, Apple charging specification (for i-Pad & i-Phones) and specs from Samsung Galaxy family.

The IC is used to facilitate charging procedure when most of the mainstream handheld devices are detected.

The CW3003 and CW3004 are suitable for all the charger products using USB interface like power bank and wall adapter. ICs are provided with enhanced ESD protection up to +/-8kV with application on DP/DM Pins.

CW3003 and CW3004 are both available in tiny SOT23-6L package.

Notice: CellWise reserves the rights to change the datasheet and products without notification.

Type number

CW3003/4 X X X X

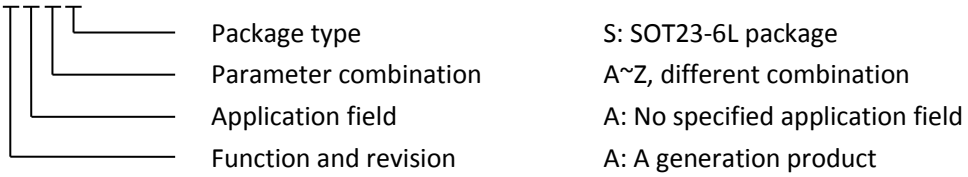

Absolute Maximum Ratings

Voltage on VCC Pin Relative to GND	GND-0.3 to GND+6V
Voltage on DPx, DMx Relative to GND	GND-0.3 to VCC+0.3V
Operating Temperature Range	-30°C to 80°C
Junction Temperature	150°C
Store Temperature Range	-55°C to 125°C

Caution:

Stresses beyond "Absolute Maximum Ratings" condition may cause permanent damage to the device. These are stress ratings only and functional operation of the device at these or any other beyond those indicated in the operational sections of the specifications is not implied. Exposure to absolute maximum rating conditions for extended periods may affect device reliability.

Pin Arrangement and Description

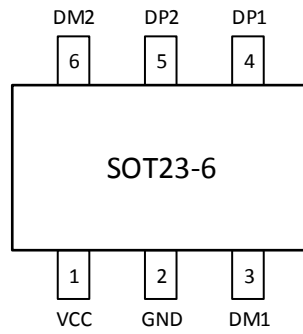

Fig1. Pin arrangement

Pin No.	Pin Name	Description
1	VCC	USB port VBUS power input
2	GND	Ground
3	DM1	USB negative data-channel to external USB device, port 1
4	DP1	USB positive data-channel to external USB device, port 1
5	DP2	USB positive data-channel to external USB device, port 2
6	DM2	USB negative data-channel to external USB device, port 2

Table1. Pin Description

Electrical Characteristics Recommended DC Operating Conditions

($4.5 \leq V_{CC} \leq 5.5$, $T_A = -40 \sim 80^\circ\text{C}$, unless otherwise specified.)

PARAMETER	SYMBOL	CONDITIONS	Min.	Typ.	Max.	UNITS
VCC Voltage			4.5		5.5	V
VCC POR Voltage	$V_{CC_{POR}}$		3.5		3.9	V
VCC POR Hysteresis	$V_{CC_{POR_HYS}}$			250		mV

Table2. Electrical Operating Parameters

DC Electrical Characteristics

($4.5 \leq V_{CC} \leq 5.5$, $T_A = -40 \sim 80^\circ\text{C}$, unless otherwise specified.)

PARAMETER	SYMBOL	CONDITIONS	Min.	Typ.	Max.	UNITS
DC Current Consumption	I_{VCC}			360	480	μA
Output Resistance on DPx/DMx pin	R_{OUT}	Output voltage=2.7		23		$\text{k}\Omega$
		Output voltage=2.0		30		$\text{k}\Omega$
Default Voltage on DPx/DMx pin	V_{OUT}	Output voltage=2.7, VCC=5V	2.6	2.7	2.8	V
		Output voltage=2.0, VCC=5V	1.9	2.0	2.1	V
Short Condition Resistance	R_{DMDP}			50		Ω

Table3. DC Electrical Characteristics

Function

CW3003 (CW3004) is a specified dual-channel USB charger controller IC for external device charging. CW3003 (CW3004), integrated with intelligent USB detection circuits, can identify most of the handheld equipment in market, such as Apple, Samsung, HTC mobile phones and other USB supplied devices.

IC monitors the DP/DM voltage all the time, and automatically emulates the corresponding USB type for the attached device. Then, the attached device can employ a big current as MAX as 2.4A to charge itself.

Controller IC only changes the DP/DM voltage to suitable value for different devices; it does not control the charging current loop. The actual charge current is determined by the power supply and the charge management IC in attached device.

USB Charge Scheme

CW3003 and CW3004 contain the entire popular USB charge modes. However, for Apple device charging, CW3003 supports 2.4A+1A mode, and CW3004 supports 2.4A+2.4A mode.

IC Type	Channel	DP Voltage	DM Voltage	Current
CW3003	1*	2.7V	2.7V	2.4A
	2**	2.0V	2.7V	1.0A
CW3004	1	2.7V	2.7V	2.4A
	2	2.7V	2.7V	2.4A

Table4. Charging Schemes

*Signal lines of Channel 1 are DP1 and DM1

**Signal lines of Channel 2 are DP2 and DM2

Application Circuits

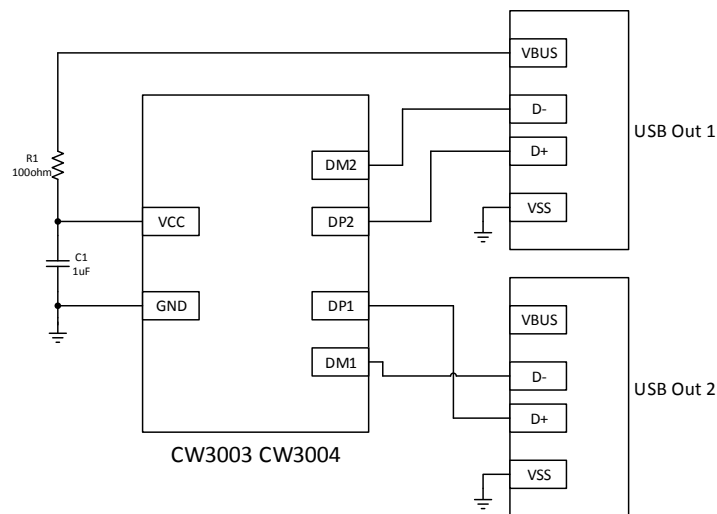

Fig2. Typical application circuits