

Ordering Information

Ordering Number	Part Number	Features	Package
DSAC-L762-11CH	CX20762-11Z	USB interface	48-pin QFN
The device is lead-free (Pb Free) and RoHS compliant.			

Revision History

Revision	Date	Description
A	July 19, 2011	Initial release
B	June 29, 2012	Revision B release

© 2011, 2012, Conexant Systems, Inc.
All Rights Reserved.

Information in this document is provided in connection with Conexant Systems, Inc. ("Conexant") products. These materials are provided by Conexant as a service to its customers and may be used for informational purposes only. Conexant assumes no responsibility for errors or omissions in these materials. Conexant may make changes to this document at any time, without notice. Conexant advises all customers to ensure that they have the latest version of this document and to verify, before placing orders, that information being relied on is current and complete. Conexant makes no commitment to update the information and shall have no responsibility whatsoever for conflicts or incompatibilities arising from future changes to its specifications and product descriptions.

No license, express or implied, by estoppel or otherwise, to any intellectual property rights is granted by this document. Except as provided in Conexant's Terms and Conditions of Sale for such products, Conexant assumes no liability whatsoever.

THESE MATERIALS ARE PROVIDED "AS IS" WITHOUT WARRANTY OF ANY KIND, EITHER EXPRESS OR IMPLIED, RELATING TO SALE AND/OR USE OF CONEXANT PRODUCTS INCLUDING LIABILITY OR WARRANTIES RELATING TO FITNESS FOR A PARTICULAR PURPOSE, CONSEQUENTIAL OR INCIDENTAL DAMAGES, MERCHANTABILITY, OR INFRINGEMENT OF ANY PATENT, COPYRIGHT OR OTHER INTELLECTUAL PROPERTY RIGHT. CONEXANT FURTHER DOES NOT WARRANT THE ACCURACY OR COMPLETENESS OF THE INFORMATION, TEXT, GRAPHICS OR OTHER ITEMS CONTAINED WITHIN THESE MATERIALS. CONEXANT SHALL NOT BE LIABLE FOR ANY SPECIAL, INDIRECT, INCIDENTAL, OR CONSEQUENTIAL DAMAGES, INCLUDING WITHOUT LIMITATION, LOST REVENUES OR LOST PROFITS, WHICH MAY RESULT FROM THE USE OF THESE MATERIALS.

Conexant products are not intended for use in medical, lifesaving or life sustaining applications. Conexant customers using or selling Conexant products for use in such applications do so at their own risk and agree to fully indemnify Conexant for any damages resulting from such improper use or sale.

The following are trademarks of Conexant Systems, Inc.: Conexant® and the Conexant C symbol. Product names or services listed in this publication are for identification purposes only, and may be trademarks of third parties. Third-party brands and names are the property of their respective owners.

For additional disclaimer information, please consult Conexant's Legal Information posted at www.conexant.com which is incorporated by reference.

Conexant Lead-free products are China RoHS Compliant: 

Reader Response: Conexant strives to produce quality documentation and welcomes your feedback. Please send comments and suggestions to tech.pubs@conexant.com. For technical questions, contact your local Conexant sales office or field applications engineer.

Contents

Figures	5
Tables	7
1 Introduction	9
1.1 Summary	9
1.2 Features	9
1.2.1 Codec Features	9
1.2.2 Package and Ordering Information	10
1.2.3 CX20762 Interface Diagram	10
1.3 Applications	10
2 Hardware Interface	11
2.1 General	11
2.1.1 USB Interface	11
2.1.2 Audio Signals	11
2.1.3 Keypad Interface	11
2.1.4 Crystal Signals	11
2.1.5 LED Control Signals	11
2.1.6 Additional Control Signals	11
2.2 Block Diagram	12
2.3 Pin Assignments and Signal Definitions	13
2.4 Electrical Characteristics	18
2.5 Crystal Specifications Requirements	21
2.6 CX20762 Package Dimensions	22
3 Reference Design and Application Information	23
3.1 CX20762 Reference Schematic	23
3.2 Application Information	23
3.2.1 Digital Volume, Playback Mute, and Microphone Mute Buttons	23
3.2.2 LED Functionality	23
3.2.3 Inrush Current Circuit	23
3.2.4 Microphone Input	23
3.2.5 Cable Recommendations	23

Figures

- Figure 1. CX20762 Interface Diagram 10
- Figure 2. CX20762 Block Diagram 12
- Figure 3. CX20762 Hardware Interface Signals 14
- Figure 4. CX20762 48-Pin QFN Pin Signals 15
- Figure 5. Microphone Input Frequency Response (44.1k Sampling Rate) 19
- Figure 6. Headphone Output Frequency Response (44.1k Sampling Rate) 20
- Figure 7. Package Dimensions 48-Pin QFN 22

Tables

Table 1.	Package and Ordering Information	10
Table 2.	CX20762 Pin List.	13
Table 3.	CX20762 Hardware Signal Definitions	16
Table 4.	CX20762 DC Supply Voltages	18
Table 5.	CX20762 Amplifier Characteristics	18
Table 6.	CX20762 DC Characteristics – TTL Compatible (GPIOs, Keypad Interface, LCD Interface)	18
Table 7.	CX20762 Analog Performance Characteristics	18
Table 8.	Power Measurements	20
Table 9.	Crystal Specifications	21

Introduction

1.1 Summary

The Conexant CX20762 is a low-cost USB audio codec with on-chip configurable hardware equalizer feature in the USB Audio solutions family. The device is optimized with 16-bit DAC and 16-bit ADC for music and voice communication applications. CX20762 features 4 bands parametric EQ for playback and 2 bands for recording, Zipper Noise Filter, Side tone, microphone boost, and headphone driver. The entire reference design can fit on a small PCB, ideal for USB headset, headphone, handset, and microphone designs. This solution is a full-speed compliant USB codec with on-chip configurable equalizer in a low cost effective 48-pin QFN package

1.2 Features

1.2.1 Codec Features

- ◆ Stereo DAC, 16-bit
 - 44.1 kHz sampling rate
- ◆ Stereo ADC, 16-bit
 - 44.1 kHz sampling rate
- ◆ USB 2.0 full-speed compliant
- ◆ Headphone driver
 - 4 bands digital equalizer for playback
- ◆ Microphone Boost, 10, 20, 30, 40 dB
 - 2 bands digital equalizer for recording
- ◆ Microphone Bias
- ◆ Side tone
- ◆ Digital volume up/down control
- ◆ Mic Mute with LED
- ◆ Playback mute with LED GPIO
- ◆ USB bus powered 5 V, 500 mA
- ◆ 48-pin QFN package

1.2.2 Package and Ordering Information

Table 1 provides the package and ordering information

Table 1. Package and Ordering Information

Ordering Number	Part Number	Features	Package
DSAC-L762-11CH	CX20762-11Z	USB interface	48-pin QFN
The device is lead-free (Pb Free) and RoHS compliant.			

1.2.3 CX20762 Interface Diagram

Figure 1 provides a diagram of the CX20762 interface.

Figure 1. CX20762 Interface Diagram

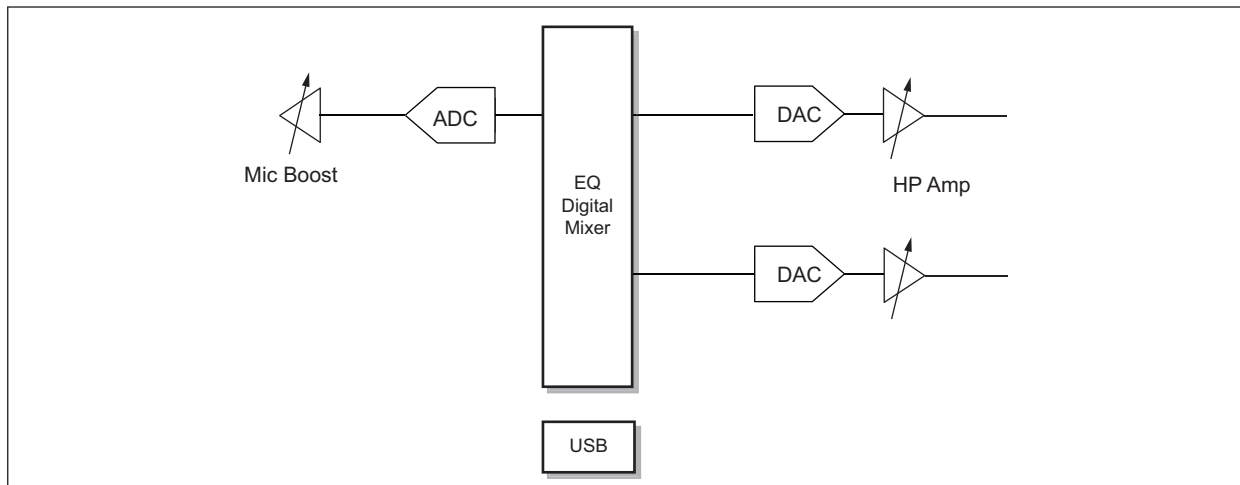

1.3 Applications

- ◆ USB Headset
- ◆ USB headphone
- ◆ USB Handset
- ◆ USB Microphone

Hardware Interface

2.1 General

2.1.1 USB Interface

The USB interface conforms to the USB specification version 2.0

The USB signals are:

- ◆ USB_DP, Serial data plus
- ◆ USB_DM, Serial data minus

2.1.2 Audio Signals

Audio interface signals supported are:

- ◆ Stereo Headphone (HP_L and HP_R)
- ◆ Microphone (MIC_L)
- ◆ Microphone Bias (MICBIAS)
- ◆ Headphone Jack Sense (HP_SENSE)

2.1.3 Keypad Interface

- ◆ Key Scan IN [0:3] Keypad interface
- ◆ Key Scan OUT Keypad interface

2.1.4 Crystal Signals

- ◆ XTALI, 24.0 MHz crystal in
- ◆ XTALO, 24.0 MHz crystal out

2.1.5 LED Control Signals

- ◆ Microphone Mute LED
- ◆ General LED

2.1.6 Additional Control Signals

- ◆ Reset
- ◆ USB 5V Detect
- ◆ Configuration Selection Pins

2.2 Block Diagram

Figure 2. CX20762 Block Diagram

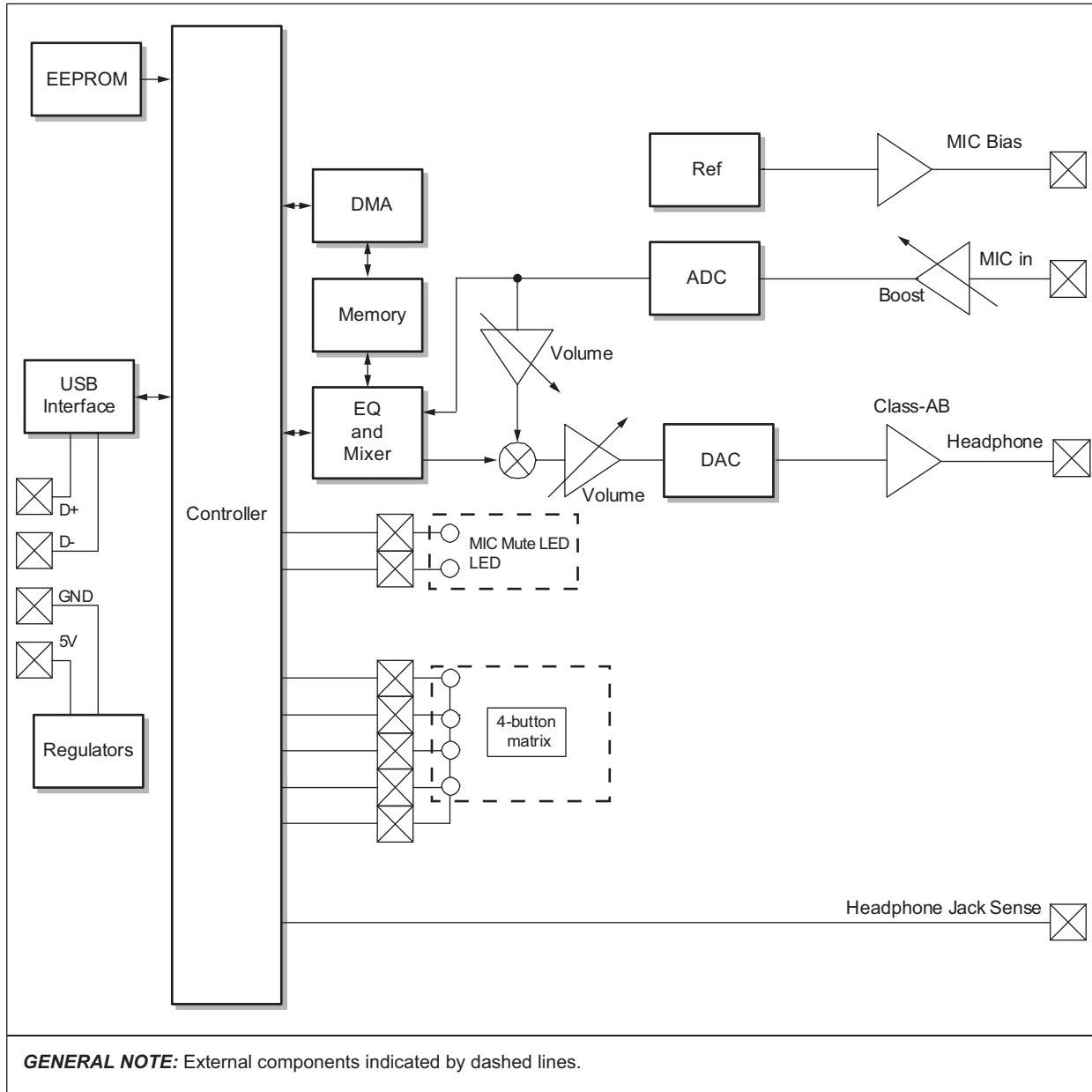

2.3 Pin Assignments and Signal Definitions

The CX20762 pins are listed in [Table 2](#), and the pinout is shown in [Figure 3](#). The CX20762 48-pin QFN hardware interface signals are shown by major interface in [Figure 3](#) and by pin number in [Figure 4](#).

Table 2. CX20762 Pin List

Pin No.	CX20762 Signal Name
1	RSVD
2	NVCLK
3	NVDATA
4	RSVD
5	USB_DP
6	USB_DM
7	VDDO
8	XTALO
9	XTALI
10	VDD
11	V5REG
12	V3.3ANA
13	HP_R
14	HP_L
15	RSVD
16	RSVD
17	RSVD
18	MIC_L
19	RSVD
20	MICBIAS
21	VREF
22	KSIN0
23	KSIN1
24	KSIN2
25	RSVD
26	RSVD
27	RSVD
28	VBUS_R
29	RSVD
30	VBUS_L
31	RSVD
32	TEST
33	VDDO
34	5V_USB_DET

Table 2. CX20762 Pin List

Pin No.	CX20762 Signal Name
35	RSVD
36	RSVD
37	KSOUT
38	KSIN3
39	LED0
40	SELECT0
41	SELECT1
42	EQ_SEL
43	SELECT2
44	RSVD
45	RSVD
46	LED1
47	RST#
48	RSVD
49	Ground Paddle

Figure 3. CX20762 Hardware Interface Signals

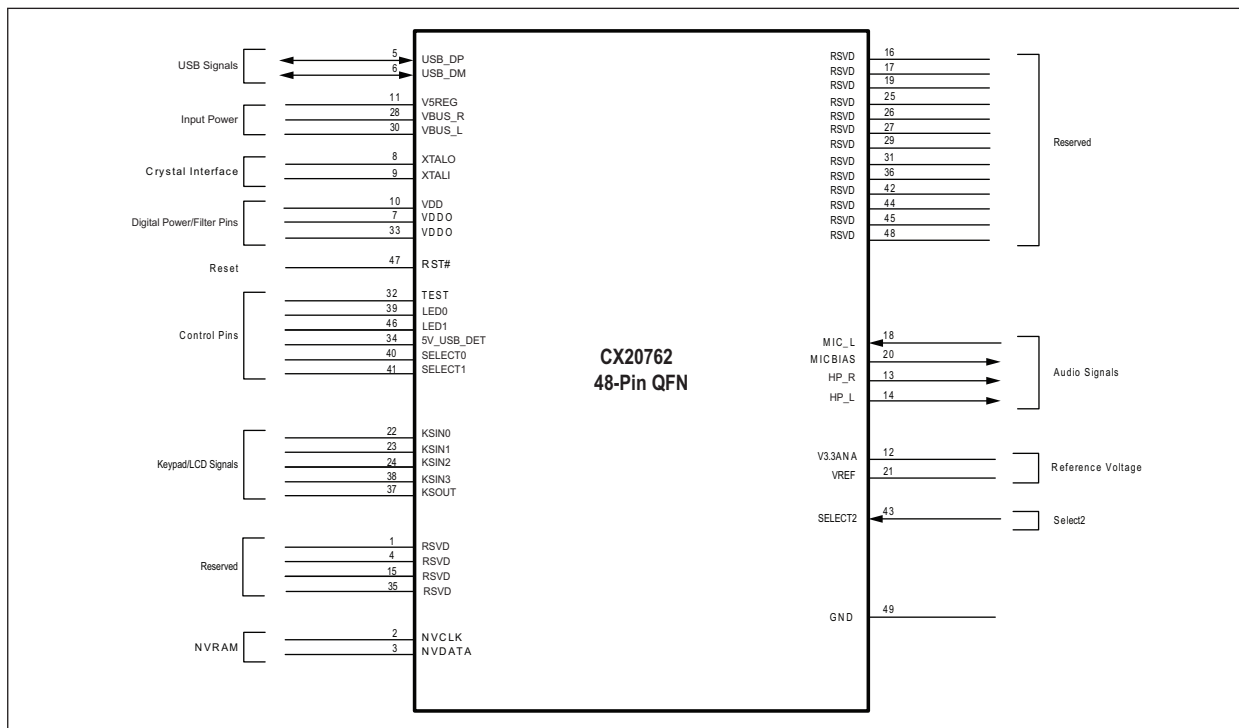

Figure 4. CX20762 48-Pin QFN Pin Signals

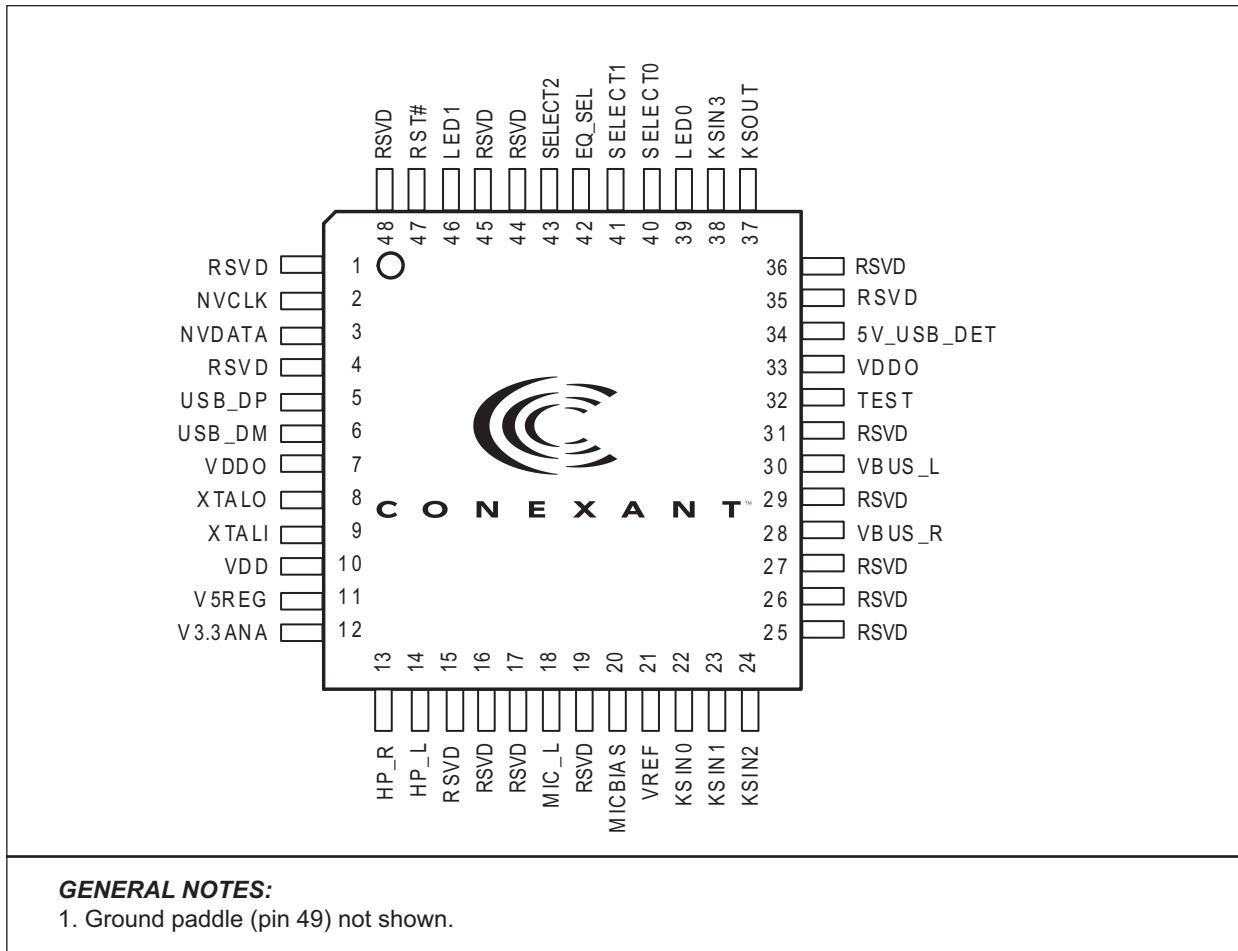

Table 3. CX20762 Hardware Signal Definitions (1 of 2)

Label	Pin	I/O Type	Signal Name/Description															
Crystal Signals																		
XTALI	9	Digital In	Crystal In. Connect XTALI to a 24.0 MHz crystal circuit.															
XTALO	8	Digital Out	Crystal Out. Connect XTALO to the crystal circuit return.															
USB Signals																		
USB_DP	5	Digital In	USB Data Plus															
USB_DM	6	Digital In	USB Data Minus															
Digital Power and Filter Pins																		
V5REG	11	PWR	+5V Input power. Connect to USB 5V or external 5V supply.															
VBUS_R	28	PWR	+5V power. Connect to USB 5V or external 5V supply.															
VBUS_L	30																	
VDD	10	PWR	Internal 1.8V core power. Connect to ground through 0.1 μ F capacitor.															
VDDO	7, 33	PWR	Internal 3.3V power. Connect each pin to ground through 0.1 μ F capacitor.															
Control Signals																		
RST#	47	Digital In	Reset. Active low input asserted to initialize registers, sequencers, and signals to a consistent reset state.															
LED0	39	Digital Out	MUTE_LED. Turns external LED on when microphone mute button pushed. Connect to anode of LED.															
LED1	46	Digital Out	GENERAL_LED. Turns external LED on as defined by designer. Connect to anode of LED. Default is playback mute LED.															
TEST	32	Digital In	TEST. Connect to ground through 0 Ω resistor. Include test point on this pin for One Time Programmable programming.															
5V_USB_DET	34	Digital In	5V_USB_DETECT. Connect this pin to USB 5V through external resistor divider.															
SELECT0, SELECT1	40, 41	Digital In	<p>CX20762 can be configured to support 4 different terminal types by using Control Signals section pins:</p> <table border="1" style="width: 100%; border-collapse: collapse;"> <thead> <tr> <th></th> <th>SELECT1</th> <th>SELECT0</th> </tr> </thead> <tbody> <tr> <td> Option 1 (Default-headset, Stereo headphone and mono mic) Playback terminal type: Headset stereo earphone Record terminal type: Headset mono microphone </td> <td style="text-align: center;">0</td> <td style="text-align: center;">0</td> </tr> <tr> <td> Option 2 (Microphone, mono mic) Record terminal type: Mono microphone </td> <td style="text-align: center;">0</td> <td style="text-align: center;">1</td> </tr> <tr> <td> Option 3 (Speakers and mono mic) Playback terminal type: Speakers Record terminal type: Mono microphone </td> <td style="text-align: center;">1</td> <td style="text-align: center;">0</td> </tr> <tr> <td> Option 4 (headset, mono headphone and mono mic) Playback terminal type: Headset mono earphone Record terminal type: Headset mono microphone </td> <td style="text-align: center;">1</td> <td style="text-align: center;">1</td> </tr> </tbody> </table> <p>Note: 0 = 10k pull-down resistor to ground. 1 = 10k pull-up resistor to 3.3VD.</p>		SELECT1	SELECT0	Option 1 (Default-headset, Stereo headphone and mono mic) Playback terminal type: Headset stereo earphone Record terminal type: Headset mono microphone	0	0	Option 2 (Microphone, mono mic) Record terminal type: Mono microphone	0	1	Option 3 (Speakers and mono mic) Playback terminal type: Speakers Record terminal type: Mono microphone	1	0	Option 4 (headset, mono headphone and mono mic) Playback terminal type: Headset mono earphone Record terminal type: Headset mono microphone	1	1
	SELECT1	SELECT0																
Option 1 (Default-headset, Stereo headphone and mono mic) Playback terminal type: Headset stereo earphone Record terminal type: Headset mono microphone	0	0																
Option 2 (Microphone, mono mic) Record terminal type: Mono microphone	0	1																
Option 3 (Speakers and mono mic) Playback terminal type: Speakers Record terminal type: Mono microphone	1	0																
Option 4 (headset, mono headphone and mono mic) Playback terminal type: Headset mono earphone Record terminal type: Headset mono microphone	1	1																

Table 3. CX20762 Hardware Signal Definitions (2 of 2)

Label	Pin	I/O Type	Signal Name/Description
Keypad/LCD Signals			
KSIN[0:3]	22, 23, 24, 38	Digital In	Keypad Scan Inputs. Assignment for standard 4 buttons: KSIN0: Volume Up KSIN1: Volume Down KSIN2: Playback Mute KSIN3: Microphone Mute
KSOUT	37	Digital Out	Keypad Scan Output. Outputs a strobe signal as part of the process to detect if volume up, volume down, microphone mute, or playback mute buttons have been pushed.
NVRAM Signals			
NVCLK	2	Digital Out	NVRAM Clock. Connect to clock pin of external EEPROM.
NVDATA	3	Digital I/O	NVRAM Data. Connect to data pin of external EEPROM.
Audio I/O Signals			
MIC_L	18	Analog In	Left Microphone. Connect to internal microphone or jack.
MICBIAS	20	PWR	Microphone Bias.
HP_L	14	Analog Out	Left Headphone.
HP_R	13	Analog Out	Right Headphone.
SELECT2	43	Digital In	Headphone sense. If asserted (low), headphone output is enabled.
Analog Power and Filter Signals			
V3.3ANA	12	PWR	Internal Analog 3.3V Power. Connect to ground through 10 μ F and 0.1 μ F capacitor.
VREF	21	PWR	Internal 1.65 VREF Power. Connect to ground through 1 μ F capacitor.
Ground Signal			
GROUND	49	Power	Ground Paddle.
Reserved			
RVSD	1, 4, 15, 16, 17, 19, 25, 26, 27, 29, 31, 35, 36, 44, 45, 48	—	Reserved.

2.4 Electrical Characteristics

Table 4. CX20762 DC Supply Voltages

Parameter	Symbol	Min.	Typ.	Max.	Units	Notes
Digital Power Supply	V5REG	4.5	5.0	5.25	V	
Core Voltage	VDD	1.71	1.8	1.89	V	
Digital 3.3 V	VDDO	3.0	3.3	3.6	V	
Analog 3.3 V	V3.3ANA	3.0	3.3	3.6	V	
VREF	VREF	1.575	1.65	1.7325	V	

Table 5. CX20762 Amplifier Characteristics

Parameter	Symbol	Min.	Typ.	Max.	Units	Notes
Headphone Amp Power	P _{STEREO}	—	30	—	mW (RMS)	

Table 6. CX20762 DC Characteristics – TTL Compatible (GPIOs, Keypad Interface, LCD Interface)

Parameter	Symbol	Min	Typ	Max	Units	Notes
Input Voltage Low	V _{IL}	-0.5	—	0.8	V	
Input Voltage High	V _{IH}	2.0	—	VDDO+0.5	V	
Output Voltage Low	V _{OL}	0	—	0.4	V	
Output Voltage High	V _{OH}	2.4	—	VDDO	V	
GPIO Output sink current at 0.4 V maximum	-	—	—	12	mA	
GPIO Output source current at 2.97 V minimum	-	—	—	12	mA	
GPIO rise/fall time	-	—	—	4	ns	25% to 75%

GENERAL NOTES: Test Conditions unless otherwise stated: VDDO=+3.3±0.3 VDC; T_A = 0°C to 70°C; external load = 50 pF

Table 7. CX20762 Analog Performance Characteristics (1 of 2)

Parameter	Minimum	Typical	Maximum	Units
Full Scale Input Voltage				
MIC (+20 dB Boost on)	—	0.1	—	V _{rms}
MIC (+20 dB Boost off)	—	1.0	—	V _{rms}
Full Scale Output Voltage				
Headphone	—	1.0	—	V _{rms}
Analog Dynamic Range				
DAC (Class AB Headphone)	—	-90	—	dB FSA
ADC	—	-87	—	dB FSA
Analog Frequency Response (±1 dB limits)	20	—	20,000	Hz
Total Harmonic Distortion + Noise (THD+N)				
DAC (Class AB Headphone)	—	0.005	—	%
ADC	—	0.006	—	%
D/A and A/D Frequency Response (±0.25 dB limits)	20	—	20,000	Hz
Attenuation, Gain Step Size	—	1	—	dB
Interchannel Gain Mismatch (Difference between errors)	—	0.2	—	dB

Table 7. CX20762 Analog Performance Characteristics (2 of 2)

Parameter	Minimum	Typical	Maximum	Units
Absolute Gain Step Error at any given setting	—	—	0.2	dB
Microphone Input Resistance	—	5	—	kΩ
Input Capacitance	—	5	—	pF
Vrefout				
50%	—	1.65	—	V
80%	—	2.64	—	V
DC Offset				
ADC	—		10	mV
DAC	—		20	mV

GENERAL NOTES:

1. The ratio of the rms output level with 997 Hz full scale input to the rms output level with all zeros into the digital input. Measured “A wtd” over a 20 Hz to a 20 kHz bandwidth. (AES17-1991 Idle Channel Noise or EIAJ CP-307 Signal-to-noise Ratio).
2. Stop Band rejection determines filter requirements. Out-of-Band rejection determines audible noise.
3. The integrated Out-of-Band noise generated by the DAC process, during normal PCM audio playback, over a bandwidth 28.8 to 100 kHz, with respect to a 1 VRMS DAC output.
4. Standard test conditions unless otherwise noted:
5. Temperature 25 °C
6. Analog Supply (V3.3ANA) 3.3 V ±0.3 V
7. Digital Supply (VDDO) 3.3 V ±0.3 V
8. Input Voltage Levels: VDD = +3.3 V
9. Logic Low 0.8 V
10. Logic High 2.4 V
11. Input signal 1 kHz sine wave
12. 0 dBV = 1 Vrms
13. Headphone test load = 32 Ω.
14. Test bench Characterization BW:
15. Pass Band 20 Hz - 20 kHz
16. Attenuation 0 dB
17. Gain on inputs 0 dB

Figure 5. Microphone Input Frequency Response (44.1k Sampling Rate)

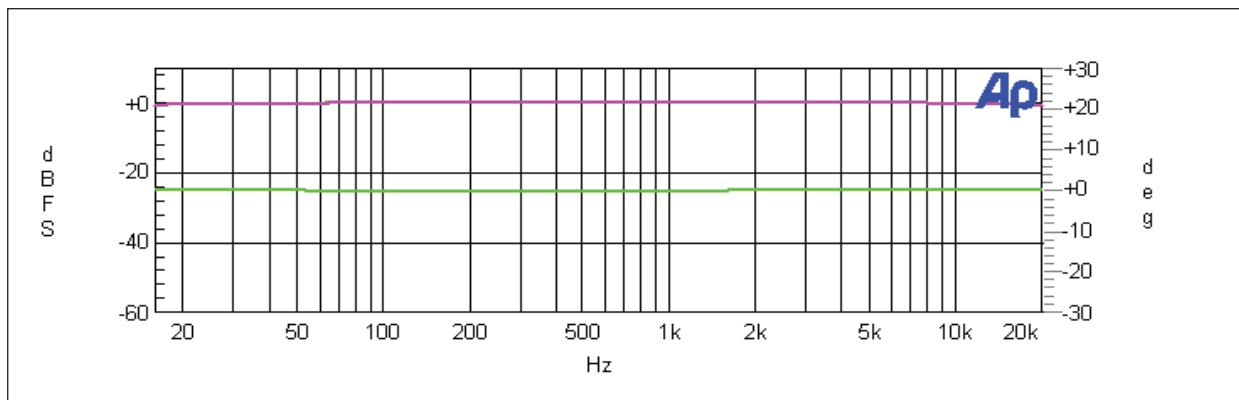
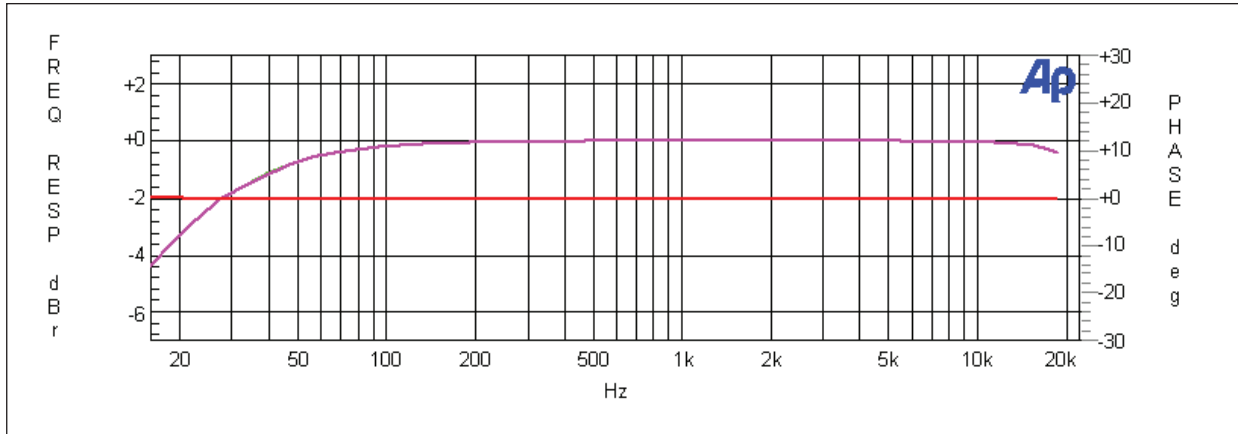

Figure 6. Headphone Output Frequency Response (44.1k Sampling Rate)



NOTE:

1. 220 μ F capacitor installed on headphone outputs. Using larger capacitors will improve the low frequency response.

Table 8. Power Measurements

Configuration	Current (mA)	Power (mW)
Boot-Up driver not loaded	86	430
Headphone plugged in, audio playing, Volume = 0dB	136	680
S1 Suspend State	1.3	6.5
S3 Suspend State	1.3	6.5
Hibernate	0	0
GENERAL NOTES:		
1. Audio: 1000 Hz tone, 0 dB, 44.1k sample rate, 16-bit		
2. Headphones: 32 Ω		

2.5 Crystal Specifications Requirements

Crystal Specifications are listed in [Table 9](#).

Table 9. Crystal Specifications

Characteristic	Value
Frequency	24.000 MHz nominal
Calibration Tolerance	±50 ppm at 25°C
Frequency Stability vs. Temperature	±50 ppm (0°C to 70°C)
Frequency Stability vs. Aging	±5 ppm/year
Oscillation Mode	Fundamental
Calibration Mode	Parallel resonant
Load Capacitance, C_L	18 pF nom.
Shunt Capacitance, C_O	7 pF max.
Series Resistance, R_1	50 Ω max.
Drive Level	100 μ W correlation; 1 mW max.
Operating Temperature	0°C to 70°C
Storage Temperature	-40°C to 85°C

2.6 CX20762 Package Dimensions

Figure 7. Package Dimensions 48-Pin QFN

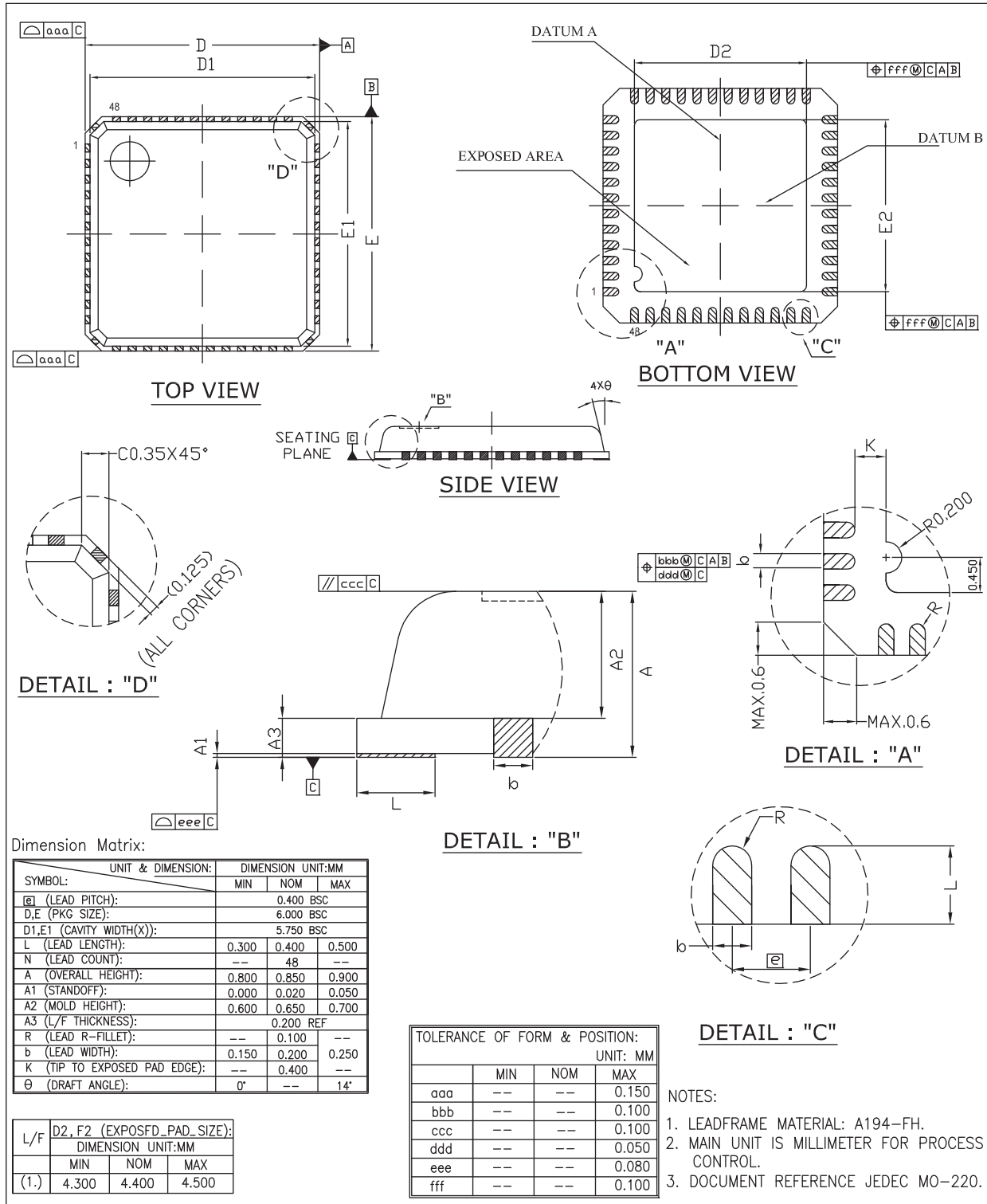

Reference Design and Application Information

3.1 CX20762 Reference Schematic

The Orcad schematic, AVL, and Allegro layout files are available as part of the CX20762 evaluation kit. Please contact your local Conexant sales office for the CX20762 evaluation kit.

3.2 Application Information

3.2.1 Digital Volume, Playback Mute, and Microphone Mute Buttons

The button scan works as follows:

- ◆ Set KSOUT scan output to 1.
- ◆ Read KSIN0, KSIN1, KSIN2, and KSIN3. If any of these are 1, then the corresponding button has been pressed.

3.2.2 LED Functionality

There are 2 pins for driving LEDs, MUTE_LED and GENERAL_LED. Connect these pins the anode of the LED. The MUTE_LED output will default to 0 and will switch states each time the mute button is pushed.

3.2.3 Inrush Current Circuit

The reference design includes an inrush current circuit. This allows for using larger bulk decoupling capacitors on the CX20762 +5V power pins without violating the USB specification for inrush current.

3.2.4 Microphone Input

The microphone input should be connected to the MICBIAS pin via a 2.2k resistor and DC isolated from the CX20762 device via a 2.2 μ F capacitor. See the reference design for details.

3.2.5 Cable Recommendations

To minimize noise and emissions, it is recommended that all cables connecting to the CX20762 board be twisted pair and shielded.

www.conexant.com
General Information:
U.S. and Canada: (800) 854-8099
International: (949) 483-6996
Headquarters – Newport Beach
4000 MacArthur Blvd.
Newport Beach, CA 92660

