



Digital Satellite Tuner RF IC

CX24113

Highly Integrated, Worldwide Broadband Satellite Front-End Solution

Conexant's portfolio includes a comprehensive suite of semiconductor solutions for broadband communications, enterprise networks and the digital home. The CX24113 is Conexant's third generation direct down-conversion satellite tuner RF IC intended for operator-based digital satellite networks and free-to-air systems. The CX24113 is a highly integrated satellite tuner solution that incorporates an advanced Fractional-N synthesizer, I2C serial interface, a fully integrated local oscillator, and variable baseband filters. It has a standalone low-noise amplifier (LNA) that can be used for a loop-through design or can provide enhanced sensitivity for free-to-air applications. The device has an improved power supply rejection ratio (PSRR), requires a single +3.3V supply, and features very low power consumption.

The CX24113 has a built-in auto-tuning machine that eliminates the need for software calibration and accelerates the calibration time. The on-chip fractional synthesizer enables fine frequency step size without adversely affecting lock time. The CX24113 does not require a balun, thus reducing external bill of materials (BOM) cost. Its highly integrated design saves valuable board space and simplifies RF layout.

The company's broad portfolio of semiconductor products also includes client-side xDSL and cable modem solutions, home network processors, broadcast video encoders and decoders, digital set-top box components and systems solutions, and dial-up modems. In addition to its IEEE 802.11a/b/g-compliant WLAN chipsets, software and reference designs, Conexant offers a suite of networking components that includes solutions for applications based on HomePlug® and HomePNA™. Additional products include a complete line of asymmetric and symmetric DSL central office solutions, which are used by service providers worldwide to deliver broadband data, voice, and video over copper telephone lines.

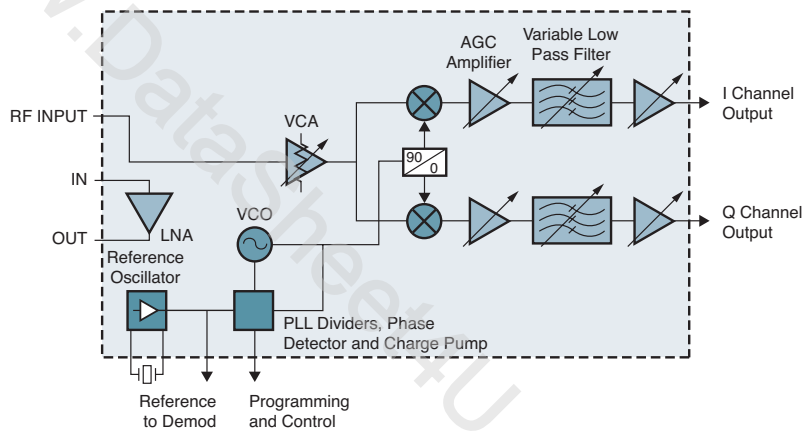

CX24113 Block Diagram



Distinguishing Features

- Single-chip RF-to-baseband satellite receiver, integrates LNA for FTA applications
- Zero-IF architecture eliminates the need for image reject filtering
- Variable baseband filters for optimal interference rejection
- Auto-tuning machine eliminates the need for software calibration
- Very low power consumption
- Small (6 mm x 6 mm) footprint
- Lead-free package

Part Number CX24113

Description Digital Satellite Tuner RF IC



CX24113 Features

- RF input: 925–2175 MHz
- Input power range: -20 to -90 dBm
- Symbol rate: 1–45 MSps
- Noise figure: 10 dB, typical
- Input IP3 at minimum gain: 10 dBm, typical
- Baseband filter bandwidth: 3–40 MHz
- Output voltage: 0.5 Vp-p @ RL > 1 k_Ω
- Operating temperature: 0–85° C
- Package type: 36-pin, Pb-free, QFN

Applications

- DSS/DVB set-top boxes
- Digital VCR (DVR)
- Commercial digital video, audio, and data receivers

© 2004, Conexant Systems, Inc. All Rights Reserved. Conexant and the Conexant logo are trademarks of Conexant Systems, Inc. All other trademarks are owned by their respective owners. Although Conexant strives for accuracy in all its publications, this material may contain errors or omissions and is subject to change without notice. **THIS MATERIAL IS PROVIDED AS IS AND WITHOUT ANY EXPRESS OR IMPLIED WARRANTIES, INCLUDING MERCHANTABILITY, FITNESS FOR A PARTICULAR PURPOSE AND NON-INFRINGEMENT.** Conexant shall not be liable for any special, indirect, incidental or consequential damages as a result of its use.

www.conexant.com
General Information:
U.S. and Canada: (888) 855-4562
International: (732) 345-7500
Headquarters
100 Schultz Drive
Red Bank, NJ 07701
Order# 102435B

