



深圳市诚芯微科技有限公司

SHENZHEN CHENGXINWEI TECHNOLOGY CO., LTD.

CX2905

Constant Voltage and Constant Current Controller(Preliminary)

产

品

说

明

书

Description

CX2905 is a highly integrated solution for SMPS applications requiring CV (constant voltage) and CC (constant current) modes.

CX2905 integrates one voltage reference, two operational amplifiers (the outputs are OR'ed together, common collectors), and a current sensing circuit.

The voltage reference, together with one operational amplifier, makes it an ideal voltage controller. The other low voltage reference, together with another operational amplifier, makes it an ideal current limiter for low side output current sensing. The current threshold is fixed, and precise. The CX2905, housed in space-saving SOT23-6L package, is ideal for space sensitive applications such as adapters, cellphone chargers, Digital Camera chargers, and other battery chargers.

Pin Configuration

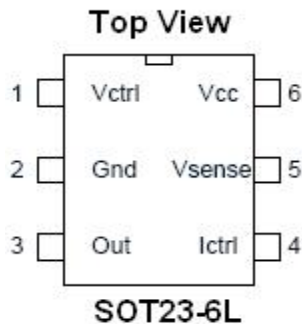

Features

- Constant Voltage and Constant Current Control
- Low Voltage Operation at 3V
- Precision Internal Voltage Reference
- Low External Component Count
- Current Sink Output Stage
- Easy Compensation
- Low AC Mains Voltage Rejection
- Rugged 2KV ESD withstand capability.
- Available in SOT-23-6L Package.
- RoHS Compliant and 100% Lead (Pb)-Free

Application

- Adapters
- Digital Camera Chargers.
- Cellphone Chargers.
- Other Battery Chargers

Ordering Information/Making Information

Device	Package	V _{OUT}
CX2905	SOT-23-6L (Lead-free)	Fixed output voltages 1.21V

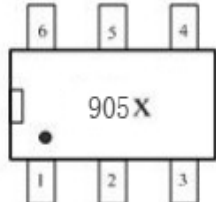
Package	Making Information
	PIN1 is down in the left-hand corner. The last character is the batch number. A dot on top right corner is for lead-free process.

Pin Description

Name	Pin#	Type	Function
V _{CTRL}	1	Analog Input	Input Pin of the Voltage Control Loop
GND	2	Power Supply	Ground Line. 0V Reference For All Voltages
V _{OUT}	3	Current Sink Output	Output Pin. Sinking Current Only
I _{CTRL}	4	Analog Input	Input Pin of the Current Control Loop
V _{SENSE}	5	Analog Input	Input Pin of the Current Control Loop
V _{CC}	6	Power Supply	Positive Power Supply Line



Absolute Maximum Rating

Symbol	Parameter	Maximum	Units
V_{CC}	DC Supply Voltage	14	V
V_{IN}	Input Supply Voltage	-0.3~ V_{CC}	V
θ_{JA}	Thermal Resistance Junction to Ambient	250	°C/W
T_J	Operating Junction Temperature Range	0 to 125	°C
T_{STG}	Storage Temperature Range	-40 to 150	°C
T_{LEAD}	Lead Temperature (Soldering 10 Sec)	260	°C

Electrical Characteristic

$V_{CC} = 5.0V$, $T_A = 25^\circ C$, unless otherwise specified.

Symbol	Parameter	Test Condition	Min	Typ	Max	Unit
Total Current Consumption						
I_{CC}	Total Supply Current - not taking the output sinking current into account			0.4		mA
		$0 < T_A < 85^\circ C$		0.5		
Voltage Control Loop						
G_{mv}	Transconduction Gain (V_{CTRL}). Sink Current Only ¹⁾			1.0		mA/mV
		$0 < T_A < 85^\circ C$		2.0		
V_{REF}	Voltage Control Loop Reference ²⁾		1.186	1.21	1.234	V
		$0 < T_A < 85^\circ C$				
I_{IBV}	Input Bias Current (V_{CTRL})			50		nA
		$0 < T_A < 85^\circ C$		100		
Current Control Loop						
G_{mi}	Transconduction Gain (I_{CTRL}). Sink Current Only ³⁾	$0 < T_A < 85^\circ C$		2.5		mA/mV
V_{SENSE}	Current Control Loop Reference ⁴⁾	$I_{OUT} = 2.5mA$		200		mV
		$0 < T_A < 85^\circ C$				
I_{IBI}	Current out of pin I_{CTRL} at -200mV			25		μA
		$0 < T_A < 85^\circ C$		50		
Output Stage						
V_{OL}	Low output voltage at 10 mA sinking current	$0 < T_A < 85^\circ C$		350		mV
I_{OS}	Output Short Circuit Current. Output to V_{CC} . Sink Current Only			22		mA
		$0 < T_A < 85^\circ C$		35		

1. If the voltage on V_{CTRL} (the negative input of the amplifier) is higher than the positive amplifier input ($V_{REF}=1.210V$), and it is increased by 1mV, the sinking current at the output OUT will be increased by 1.0mA.
2. The internal Voltage Reference is set at 1.210V. The internal Voltage Reference is fixed by bandgap, and trimmed to 0.5% accuracy at room temperature.
3. When the positive input at I_{CTRL} is lower than -200mV, and the voltage is decreased by 1mV, the sinking current at the output OUT will be increased by 2.5mA.
4. The internal current sense threshold is set to -200mV. The current control loop precision takes into account the cumulative effects of the internal voltage reference deviation as well as the input offset voltage of the trans-conduction operational amplifier.

Block Diagram

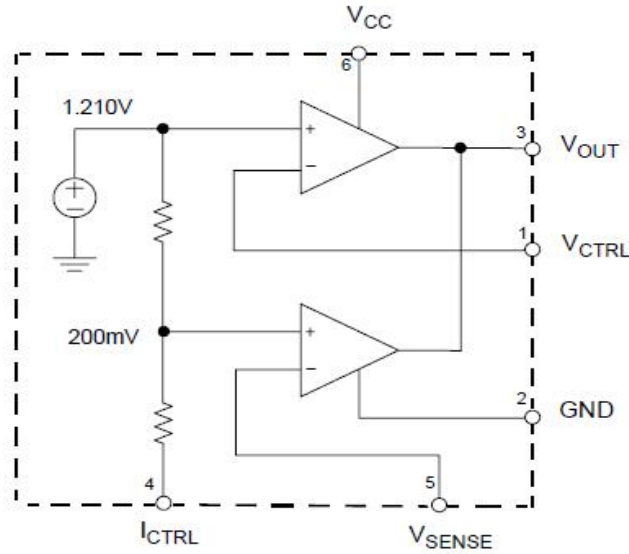

Typical Application

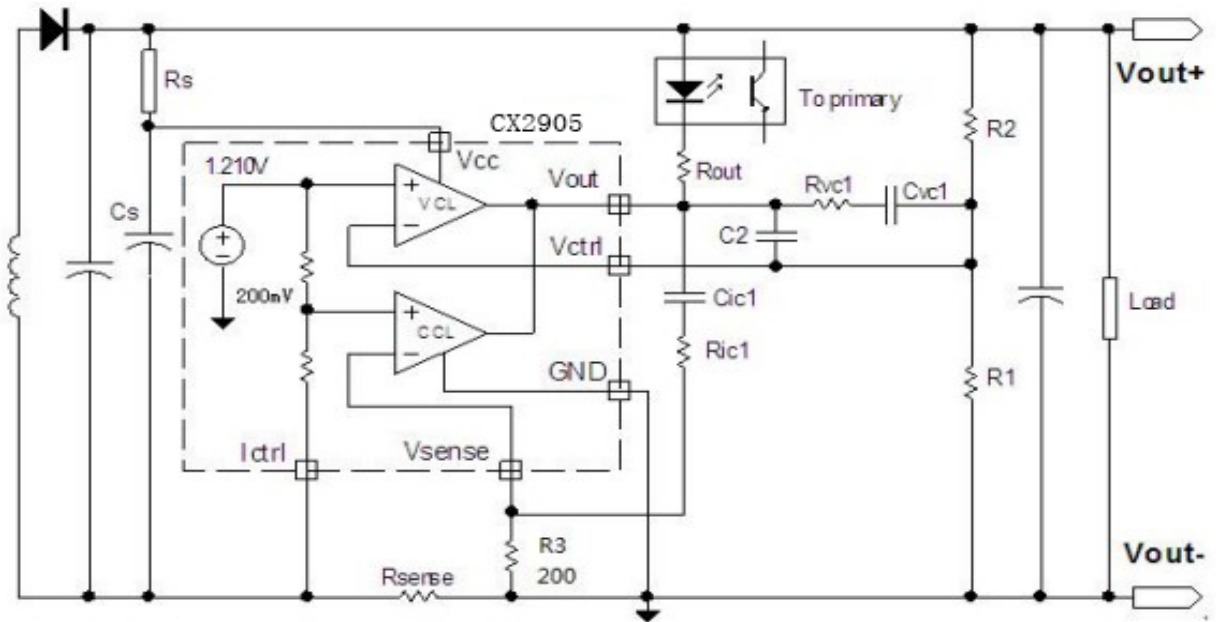

Fig.1 Typical Adapter or Battery Charger Application Using CX2905

In the above application schematic, the CX2905 is used on the secondary side of a flyback adapter (or battery charger) to provide an accurate control of voltage and current. The above feedback loop is made with an optocoupler.

$$V_{OUT} = V_{REF} \times \frac{R1 + R2}{R1}$$

$$I_{LIMIT} = \frac{V_{SENSE}}{R_{SENSE}}$$

Application Hints

Voltage Control

The voltage loop is controlled via a first transconductance operational amplifier, the resistor bridge R1, R2, and the optocoupler which is directly connected to the output.

The relation between the values of R1 and R2 should be chosen as written in Equation 1.

$$R1 = R2 \times V_{ref} / (V_{out} - V_{ref}) \quad Eq1$$

Where V_{out} is the desired output voltage. To avoid the discharge of the load, the resistor bridge R1, R2 should be highly resistive. For this type of application, a total value of 100KΩ (or more) would be appropriate for the resistors R1 and R2. As an example, with $R2 = 100K\Omega$, $V_{out} = 4.10V$, $V_{ref} = 1.210V$, then $R1 = 41.9K\Omega$.

Note that if the low drop diode should be inserted between the load and the voltage regulation resistor bridge to avoid current flowing from the load through the resistor bridge, this drop should be taken into account in the above calculations by replacing V_{out} by $(V_{out} + V_{drop})$.

Current Control

The current loop is controlled via the second trans-conductance operational amplifier, the sense resistor R_{sense} , and the optocoupler.

The control equation is:

$$R_{sense} \times I_{limit} = V_{sense} \quad Eq2$$

$$R_{sense} = V_{sense} / I_{limit} \quad Eq3$$

where I_{limit} is the desired current limit, and V_{sense} is the threshold voltage for the current control loop.

As an example, with $I_{limit} = 1A$, $V_{sense} = -200mV$, then $R_{sense} = 200m\Omega$.

Note that the R_{sense} resistor should be selected with the consideration of the Maximum Power in full load operations (P-limit).

$$P_{limit} = V_{sense} \times I_{limit} \quad Eq4$$

As an example, with $I_{limit} = 1A$, and $V_{sense} = -200mV$, $P_{limit} = 200mW$.

Consequently, for most adapter and battery charger applications, a quarter-watt resistor to make the current sensing function is sufficient.

V_{sense} threshold is achieved internally by a resistor bridge tied to the V_{ref} voltage reference. Its middle point is tied to the positive input of the current control operational amplifier, and its foot is to be connected to lower potential point of the sense resistor as shown on the following figure. The resistors of this bridge are matched in layout to provide the best precision possible.

The current sinking outputs of the two trans-conductance operational amplifiers are connected together. This makes an ORing function which ensures that whenever the current or the voltage reaches too high values, the optocoupler is activated.

The relation between the controlled current and the controlled output voltage can be described with a square characteristic as shown in the following V/I output-power graph.

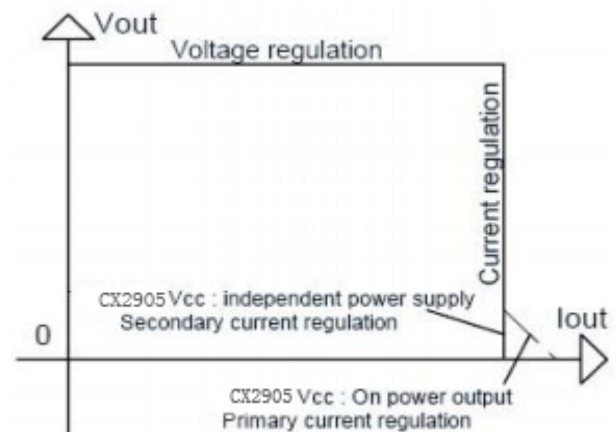

Fig.2 Output voltage versus output current

Compensation

The voltage-control trans-conductance operational amplifier can be fully compensated. Both of its output and negative input are directly accessible for external compensation components.

An example of a suitable compensation network is shown in Fig.1. It consists of a capacitor $C_{vc1}=2.2nF$ and a resistor $R_{cv1}=470K\Omega$ in series, connected in parallel with another capacitor $C_{vc2}=22pF$.

The current-control trans-conductance operational amplifier can also be fully compensated. Both of its output and negative input are directly accessible for external compensation components.

An example of a suitable compensation network is shown in Fig.1. It consists of a capacitor $C_{ic1}=2.2nF$ and a resistor $R_{ic1}=22K\Omega$ in series. When the V_{cc} voltage reaches 12V it could be interesting to limit the current coming through the output in the aim to reduce the dissipation of the device and increase the stability performances of the whole application.

An example of a suitable R_{out} value could be 330Ω in series with the opto-coupler in case $V_{cc}=12V$.

Start Up and Short Circuit Conditions

Under start-up or short-circuit conditions the CX2905 does not have a high enough supply voltage. This is due to the fact that the chip has its power supply line in common with the power supply line of the charger system. Consequently, the current limitation can only be ensured by the primary PWM module, which should be designed accordingly.

If the primary current limitation is considered not to be precise enough for the application, then a sufficient supply for the CX2905 has to be ensured under any condition. It would then be necessary to add some circuitry to supply the chip with a separate power line. This can be achieved in numerous ways, including an additional winding on the transformer.

The following schematic shows how to realize a low-cost power supply for the CX2905 (with no additional windings).

Please pay attention to the fact that in the particular case presented here, this low-cost power supply can reach voltages as high as twice the voltage of the regulated line. Since the Absolute Maximum Rating of the CX2905 supply voltage is 18V, this low-cost auxiliary power supply can only be used in applications where the regulated line voltage does not exceed 9V.

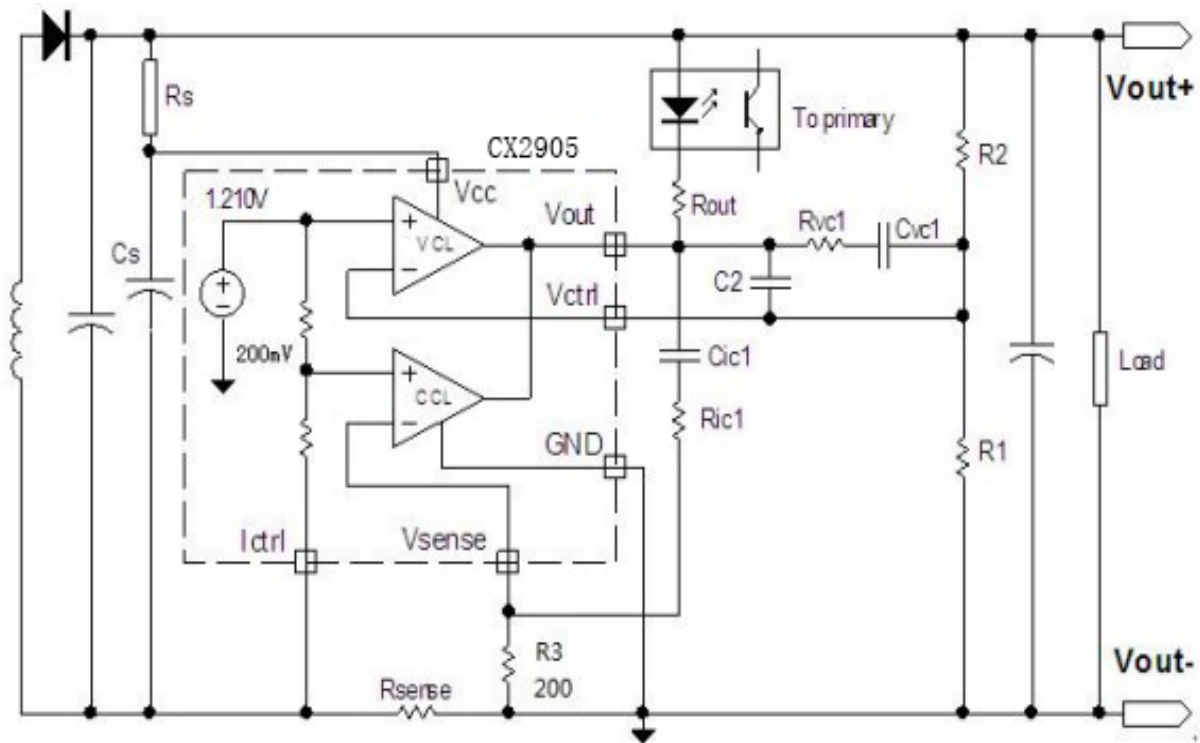
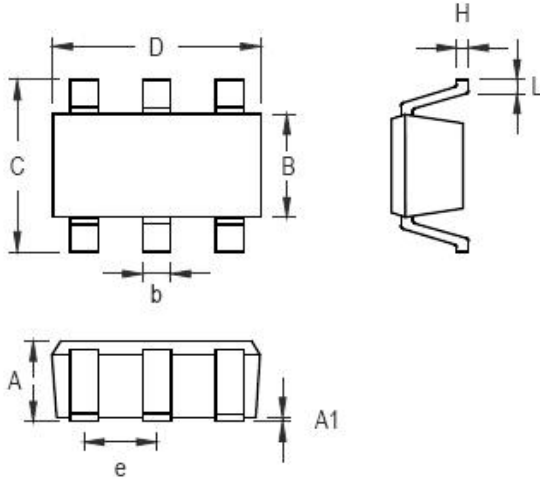

Fig. 3

OUTLINE DRAWING SOT-23-6L



Symbol	Dimensions In Millimeters		Dimensions In Inches	
	Min	Max	Min	Max
A	0.889	1.295	0.031	0.051
A1	0.000	0.152	0.000	0.006
B	1.397	1.803	0.055	0.071
b	0.250	0.560	0.010	0.022
C	2.591	2.997	0.102	0.118
D	2.692	3.099	0.106	0.122
e	0.838	1.041	0.033	0.041
H	0.080	0.254	0.003	0.010
L	0.300	0.610	0.012	0.024