

On-board type, Non-dimming, 6W, For 1 and 2 bulbs

TDK DC-AC Inverter

# CXA-M10A-L/-M10L-L/-M10M-L

## FEATURES

- The CXA-M10 series inverters for 2-cold cathode fluorescent lamps support a wide range of CCFL devices and are characterized by highly stable output current.
- Employing a resonance-type push-pull circuit, these inverters deliver sine wave output with very low noise levels.
- Through the use of four different connection methods and combinations of 1 and 2 lamps, different output currents can be selected.
- Compact, lightweight printed circuit board design.
- High efficiency (typically 80%).

## APPLICATIONS

Industrial and other equipment employing LCD panels, products employing small lamps, information terminal devices.

## TEMPERATURE AND HUMIDITY RANGES

Temperature range	Operating	-10 to +60
(°C)	Storage	-20 to +85
Humidity range(%)RH		95max. [Maximum wet-bulb temperature 38°C]

## SHAPES AND DIMENSIONS

### CXA-M10A-L/-M10L-L/-M10M-L

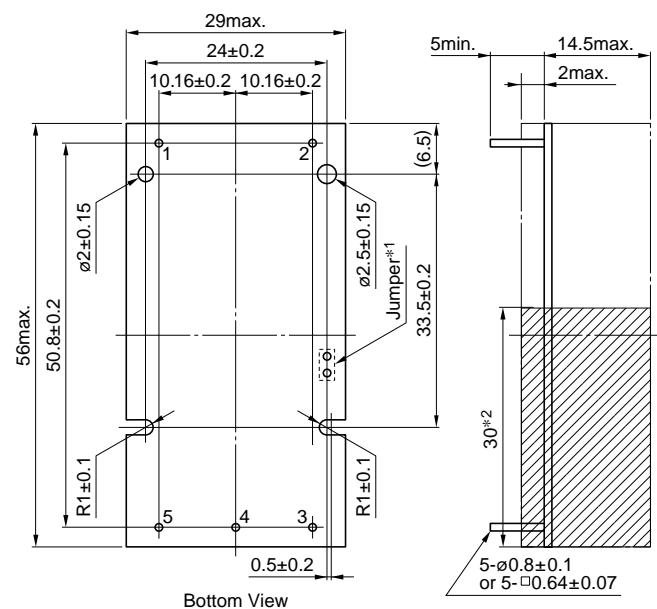

Bottom View

\*1 Terminal numbers 2 and 5 are connected by the jumper.  
Cut this jumper to let the secondary side float with respect to the primary side.

Weight: 21g typ.

\*2 High-voltage generator (The entire surface within a range of 30mm away from the end of the base in the output)

Dimensions in mm

## CIRCUIT DIAGRAMS

### CONNECTION A

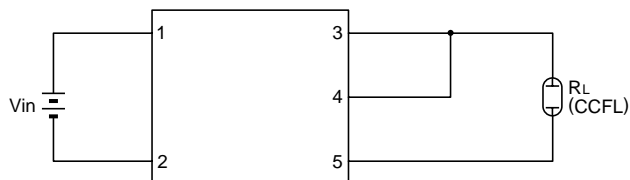

### CONNECTION B

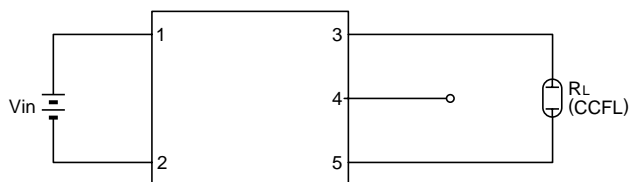

### CONNECTION C

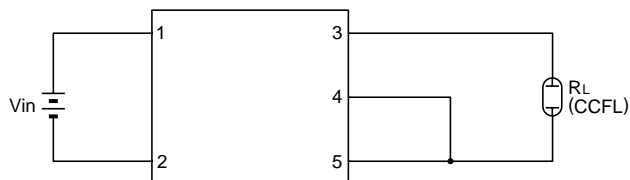

### CONNECTION D

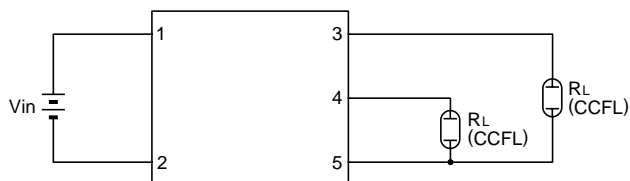

## TERMINAL NUMBERS AND FUNCTIONS

Terminal No.	Functions	CXA-M10A-L	CXA-M10L-L	CXA-M10M-L	Symbol
1	Input voltage Edc	0 to 6V 5V[nom.]	0 to 14.4V 12V[nom.]	0 to 28.8V 24V[nom.]	Vin
2		0V	0V	0V	GND
3	Output 1[High voltage] Irms	5mA	5mA	5mA	VHIGH1
4	Output 2[High voltage] Irms	5mA	5mA	5mA	VHIGH2
5	Output[Low voltage]	0V	0V	0V	VLOW

All specifications are subject to change without notice.

On-board type, Non-dimming, 6W, For 1 and 2 bulbs

TDK DC-AC Inverter

# CXA-M10A-L/-M10L-L/-M10M-L

## ELECTRICAL CHARACTERISTICS

### 5V INPUT TYPE/CXA-M10A-L

Connections	Items	Unit	Symbol	Specifications			Conditions		
				min.	typ.	max.	V <sub>in</sub> (V)	T <sub>a</sub> (°C)	R <sub>L</sub> (kΩ)
A	Output current I <sub>rms</sub>	mA	I <sub>out</sub>	9	10	11	5±1%	23±5	40
				8	10	12	5±5%	-10 to +60	30 to 50
	Input current I <sub>dc</sub>	A	I <sub>in</sub>	—	1	1.5	5±5%	-10 to +60	30 to 50
	Oscillation frequency	kHz	F <sub>L</sub>	23	28	33	5±5%	-10 to +60	30 to 50
	Open circuit output voltage E <sub>rms</sub>	V	V <sub>open</sub>	1000	1200	—	5±5%	-10 to +60	∞
Output power	W	P <sub>out</sub>	—	—	6	5±5%	-10 to +60	—	
B	Output current I <sub>rms</sub>	mA	I <sub>out</sub>	5.1	6	6.5	5±1%	23±5	67
				4.5	6	7.1	5±5%	-10 to +60	50 to 84
	Input current I <sub>dc</sub>	A	I <sub>in</sub>	—	0.6	1	5±5%	-10 to +60	50 to 84
	Oscillation frequency	kHz	F <sub>L</sub>	27	32	37	5±5%	-10 to +60	50 to 84
	Open circuit output voltage E <sub>rms</sub>	V	V <sub>open</sub>	1000	1200	—	5±5%	-10 to +60	∞
Output power	W	P <sub>out</sub>	—	—	3.6	5±5%	-10 to +60	—	
C	Output current I <sub>rms</sub>	mA	I <sub>out</sub>	4.2	5	5.4	5±1%	23±5	80
				3.7	5	5.9	5±5%	-10 to +60	60 to 100
	Input current I <sub>dc</sub>	A	I <sub>in</sub>	—	0.6	0.9	5±5%	-10 to +60	60 to 100
	Oscillation frequency	kHz	F <sub>L</sub>	23	28	33	5±5%	-10 to +60	60 to 100
	Open circuit output voltage E <sub>rms</sub>	V	V <sub>open</sub>	1000	1200	—	5±5%	-10 to +60	∞
Output power	W	P <sub>out</sub>	—	—	3	5±5%	-10 to +60	—	
D	Output current I <sub>rms</sub>	mA	I <sub>out1</sub>	4.5	5	5.5	5±1%	23±5	80
			I <sub>out2</sub>	4.5	5	5.5	5±1%	23±5	80
			I <sub>out1</sub>	4	5	6	5±5%	-10 to +60	60 to 100
			I <sub>out2</sub>	4	5	6	5±5%	-10 to +60	60 to 100
	Input current I <sub>dc</sub>	A	I <sub>in</sub>	—	1	1.5	5±5%	-10 to +60	60 to 100
	Oscillation frequency	kHz	F <sub>L</sub>	23	28	33	5±5%	-10 to +60	60 to 100
	Open circuit output voltage E <sub>rms</sub>	V	V <sub>open</sub>	1000	1200	—	5±5%	-10 to +60	∞
Output power	W	P <sub>out</sub>	—	—	3×2	5±5%	-10 to +60	—	

On-board type, Non-dimming, 6W, For 1 and 2 bulbs

TDK DC-AC Inverter

# CXA-M10A-L/-M10L-L/-M10M-L

## ELECTRICAL CHARACTERISTICS

### 12V INPUT TYPE/CXA-M10L-L

Connections	Items	Unit	Symbol	Specifications			Conditions		
				min.	typ.	max.	V <sub>in</sub> (V)	T <sub>a</sub> (°C)	R <sub>L</sub> (kΩ)
A	Output current I <sub>rms</sub>	mA	I <sub>out</sub>	9	10	11	12±1%	23±5	40
				8	10	12	12±5%	-10 to +60	30 to 50
	Input current I <sub>dc</sub>	A	I <sub>in</sub>	—	0.42	0.63	12±5%	-10 to +60	30 to 50
	Oscillation frequency	kHz	F <sub>L</sub>	23	28	33	12±5%	-10 to +60	30 to 50
	Open circuit output voltage E <sub>rms</sub>	V	V <sub>open</sub>	1000	1200	—	12±5%	-10 to +60	∞
	Output power	W	P <sub>out</sub>	—	—	6	12±5%	-10 to +60	—
B	Output current I <sub>rms</sub>	mA	I <sub>out</sub>	5.1	6	6.5	12±1%	23±5	67
				4.5	6	7.1	12±5%	-10 to +60	50 to 84
	Input current I <sub>dc</sub>	A	I <sub>in</sub>	—	0.27	0.41	12±5%	-10 to +60	50 to 84
	Oscillation frequency	kHz	F <sub>L</sub>	26	31	36	12±5%	-10 to +60	50 to 84
	Open circuit output voltage E <sub>rms</sub>	V	V <sub>open</sub>	1000	1200	—	12±5%	-10 to +60	∞
	Output power	W	P <sub>out</sub>	—	—	3.6	12±5%	-10 to +60	—
C	Output current I <sub>rms</sub>	mA	I <sub>out</sub>	4.3	5	5.5	12±1%	23±5	80
				3.8	5	6	12±5%	-10 to +60	60 to 100
	Input current I <sub>dc</sub>	A	I <sub>in</sub>	—	0.23	0.35	12±5%	-10 to +60	60 to 100
	Oscillation frequency	kHz	F <sub>L</sub>	23	28	33	12±5%	-10 to +60	60 to 100
	Open circuit output voltage E <sub>rms</sub>	V	V <sub>open</sub>	1000	1200	—	12±5%	-10 to +60	∞
	Output power	W	P <sub>out</sub>	—	—	3	12±5%	-10 to +60	—
D	Output current I <sub>rms</sub>	mA	I <sub>out1</sub>	4.5	5	5.5	12±1%	23±5	80
			I <sub>out2</sub>	4.5	5	5.5	12±1%	23±5	80
			I <sub>out1</sub>	4	5	6	12±5%	-10 to +60	60 to 100
			I <sub>out2</sub>	4	5	6	12±5%	-10 to +60	60 to 100
	Input current I <sub>dc</sub>	A	I <sub>in</sub>	—	0.42	0.63	12±5%	-10 to +60	60 to 100
	Oscillation frequency	kHz	F <sub>L</sub>	23	28	33	12±5%	-10 to +60	60 to 100
	Open circuit output voltage E <sub>rms</sub>	V	V <sub>open</sub>	1000	1200	—	12±5%	-10 to +60	∞
	Output power	W	P <sub>out</sub>	—	—	3×2	12±5%	-10 to +60	—

On-board type, Non-dimming, 6W, For 1 and 2 bulbs

TDK DC-AC Inverter

# CXA-M10A-L/-M10L-L/-M10M-L

## ELECTRICAL CHARACTERISTICS

### 24V INPUT TYPE/CXA-M10M-L

Connections	Items	Unit	Symbol	Specifications			Conditions		
				min.	typ.	max.	V <sub>in</sub> (V)	T <sub>a</sub> (°C)	R <sub>L</sub> (kΩ)
A	Output current I <sub>rms</sub>	mA	I <sub>out</sub>	9	10	11	24±1%	23±5	40
				8	10	12	24±5%	-10 to +60	30 to 50
	Input current I <sub>dc</sub>	A	I <sub>in</sub>	—	0.21	0.33	24±5%	-10 to +60	30 to 50
	Oscillation frequency	kHz	F <sub>L</sub>	23	28	33	24±5%	-10 to +60	30 to 50
	Open circuit output voltage E <sub>rms</sub>	V	V <sub>open</sub>	1000	1200	—	24±5%	-10 to +60	∞
Output power	W	P <sub>out</sub>	—	—	6	24±5%	-10 to +60	—	
B	Output current I <sub>rms</sub>	mA	I <sub>out</sub>	5	6	6.4	24±1%	23±5	67
				4.4	6	7	24±5%	-10 to +60	50 to 84
	Input current I <sub>dc</sub>	A	I <sub>in</sub>	—	0.14	0.21	24±5%	-10 to +60	50 to 84
	Oscillation frequency	kHz	F <sub>L</sub>	26	31	36	24±5%	-10 to +60	50 to 84
	Open circuit output voltage E <sub>rms</sub>	V	V <sub>open</sub>	1000	1200	—	24±5%	-10 to +60	∞
Output power	W	P <sub>out</sub>	—	—	3.6	24±5%	-10 to +60	—	
C	Output current I <sub>rms</sub>	mA	I <sub>out</sub>	4.3	5	5.5	24±1%	23±5	80
				3.8	5	6	24±5%	-10 to +60	60 to 100
	Input current I <sub>dc</sub>	A	I <sub>in</sub>	—	0.12	0.19	24±5%	-10 to +60	60 to 100
	Oscillation frequency	kHz	F <sub>L</sub>	23	28	33	24±5%	-10 to +60	60 to 100
	Open circuit output voltage E <sub>rms</sub>	V	V <sub>open</sub>	1000	1200	—	24±5%	-10 to +60	∞
Output power	W	P <sub>out</sub>	—	—	3	24±5%	-10 to +60	—	
D	Output current I <sub>rms</sub>	mA	I <sub>out1</sub>	4.5	5	5.5	24±1%	23±5	80
			I <sub>out2</sub>	4.5	5	5.5	24±1%	23±5	80
			I <sub>out1</sub>	4	5	6	24±5%	-10 to +60	60 to 100
			I <sub>out2</sub>	4	5	6	24±5%	-10 to +60	60 to 100
	Input current I <sub>dc</sub>	A	I <sub>in</sub>	-	0.21	0.33	24±5%	-10 to +60	60 to 100
	Oscillation frequency	kHz	F <sub>L</sub>	23	28	33	24±5%	-10 to +60	60 to 100
	Open circuit output voltage E <sub>rms</sub>	V	V <sub>open</sub>	1000	1200	—	24±5%	-10 to +60	∞
Output power	W	P <sub>out</sub>	—	—	3×2	24±5%	-10 to +60	—	

