

Wideband Differential Amplifier (DC to 180 MHz)

Description

The CXA1077M is a bipolar IC which has been developed as a reproducing preamplifier for digital VTR. It is a 2-channel wideband differential amplifier which incorporates an output enable logic circuit.

Features

- Ultra wideband frequency characteristics: DC to 180 MHz (-3 dB down point) with differential gain 47.5 dB
- Low output offset voltage: Within ± 100 mV
- Low noise: Input short-circuit; input conversion noise in 10 kHz to 10 MHz is $2.5 \mu V_{rms}$.

Function

2-channel wideband differential amplifier (Incorporates output enable logic circuit)

Structure

Bipolar silicon monolithic IC

Application

Reproducing preamplifier for VTR and other wideband amplifiers

Absolute Maximum Rating (Ta=25°C)

- Supply voltage V_{cc} 7 V
- Operating temperature T_{opr} -25 to +75 °C
- Storage temperature T_{stg} -55 to +150 °C
- Allowable power dissipation P_d 515 mW

Recommended Operating Condition

- Supply voltage V_{cc} 4.5 to 5.5 V

Block Diagram and Pin Configuration

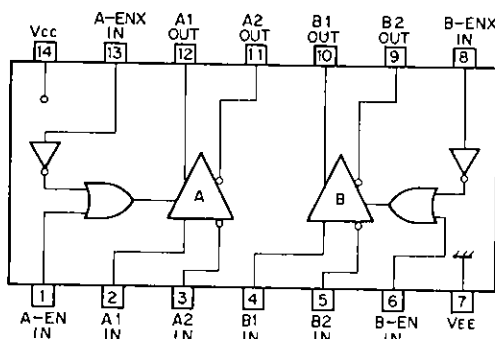

Package Outline

Unit: mm

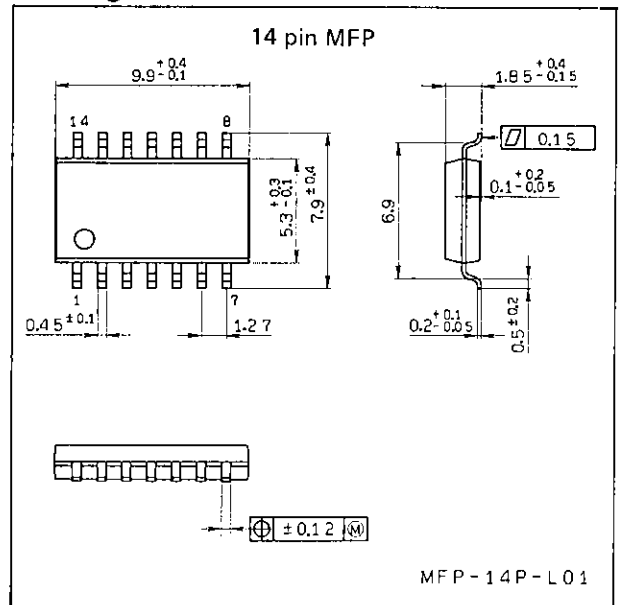

Function Table

EN \ ENX	L	H
L	OUT	OUT
H	High Z	OUT

L = Low Level (Input)
 H = High Level (Input)
 OUT = Amplifier Output
 Z = High Impedance

Pin Description

No.	Symbol	Voltage	Equivalent circuit	Description
1 6	EN IN	2.5V		Output control input pin
2 3 4 5	V _{IN}	2.2V		Signal input pin
8 13	ENX IN	2.5V		Output control input pin
9 10 11 12	V _{OUT}	2.4V		Signal output pin

Electrical Characteristics

(Ta=25°C, Vcc=5V, VEE=GND, VEN and VENX: OPEN)

Item	Symbol	Condition	Min.	Typ.	Max.	Unit
Differential amplifier voltage gain	AvD	f=100kHz	50	47.5	50	dB
Frequency bandwidth	BW	-3db down point	-	180	-	MHz
Input resistance	RIN		-	3	-	kΩ
Input capacity	CIN		-	17	-	pF
Output resistance	RO (ON)	VEN: OPEN f=100kHz	-	40	-	Ω
Output capacity	CO (OFF)	VEN: GND f=1MHz	-	8	-	pF
Output offset voltage	ΔVo		-100		100	mV
Crosstalk between channels	XTALK	f=30MHz	-	-60	-	dB
In-phase voltage elimination ratio	CMRR	f=30MHz	-	60	-	dB
Supply voltage fluctuation elimination ratio	SVRR	f=30MHz	-	50	-	dB
Circuit current	Icc	When outputting both channels	30	40	50	mA
		When outputting a single channel	24	30	36	mA
		When both channel outputs are OFF	15	19	25	mA
Input conversion noise	En	Input short-circuit	-	0.77	-	nV/√Hz
	In	Input open	-	1.6	-	PA/√Hz
Controlling voltage	VL	Low level		-	0.6	V
	VH	High level	1.6	-		V
Controlling current	IL	VL=0.6V	-330	-190	-	μA
	IH	VH=1.6V	-	-90	100	μA
ON-OFF time	TON EN	VH=5V, VL=0V	-	35	350	ns
	TOFF EN	VH=5V, VL=0V	-	80	350	ns

Description of Operation

The circuit structure of the built-in preamplifier (2 channels) is differential input system and the bias is self-bias.

The input signal is input to the input pins (A: pins 2 and 3, and B: pins 4 and 5) and the output signal can be taken out from the output pins (A: pins 11 and 12, and B: pins 9 and 10). The output impedance of the differential amplifier is approximately 40Ω and the structure of the amplifier is emitter follower.

The output signal of this differential amplifier can be controlled by the control signal of the TTL. Its truth table is shown below.

EN A : (1) B : (6)		L	H
		ENX A : (13) B : (8)	
L	OUT	OUT	
H	High Z	OUT	

L : Input Low Level
 H : Input High Level
 Out : Amp Output
 High Z : High Impedance

The built-in 2-channel circuit is completely separated except for the power supply unit consequently, it can be operated independently including its output control section.

Application Circuit

Three application circuit examples of this IC are as shown below.

1. Head amplifier of VTR, etc. (The output enable logic circuit has not yet been used)

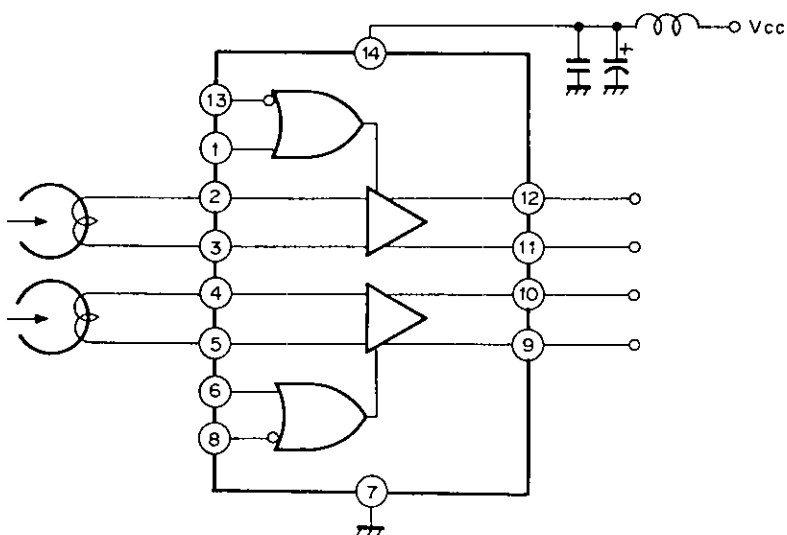

2. Wideband amplifier when control circuit has been used.

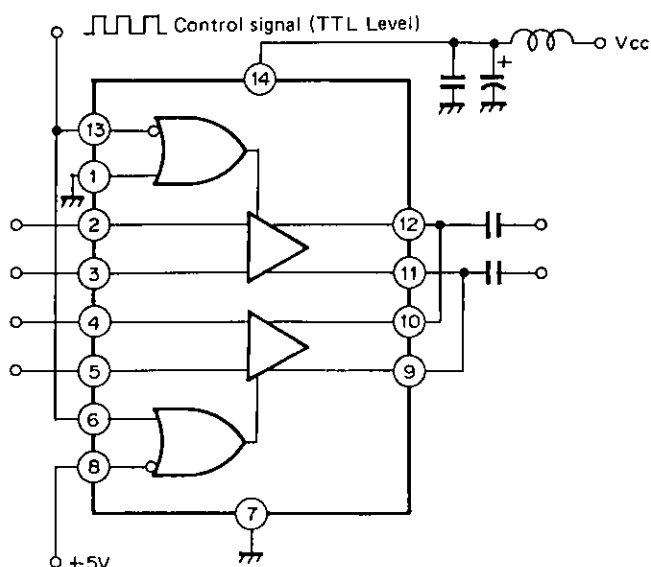

3. Wideband amplifier when it is used with a single input and a single output.

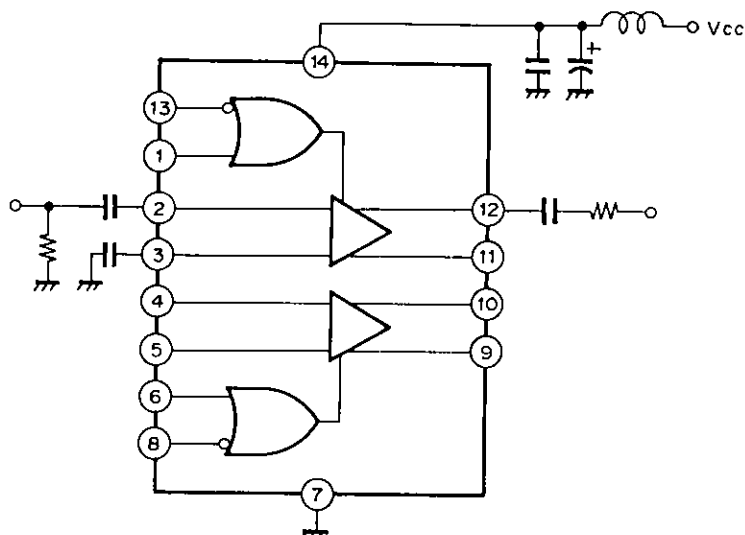
**Notes on Application**

The CXA1077M has a high voltage gain (approx. 46 dB), so that it should be used by taking special care from the following circuit structural standpoints.

1. The power supply should be decoupled by the coil capacitor.
2. Oscillation may occur when a capacitive load is applied to the output circuit.
3. Using of regulated-DC power supply is recommended.
4. There may be cases in which the effect of crosstalk between channels (Within the IC $f=30\text{ MHz}-60\text{ dB min}$) cannot be fully exercised depending on the pattern layout.

Circuit current vs. Supply voltage

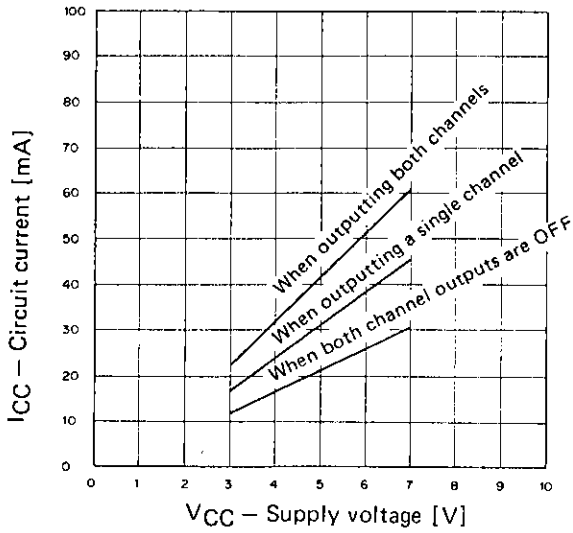

Frequency characteristics

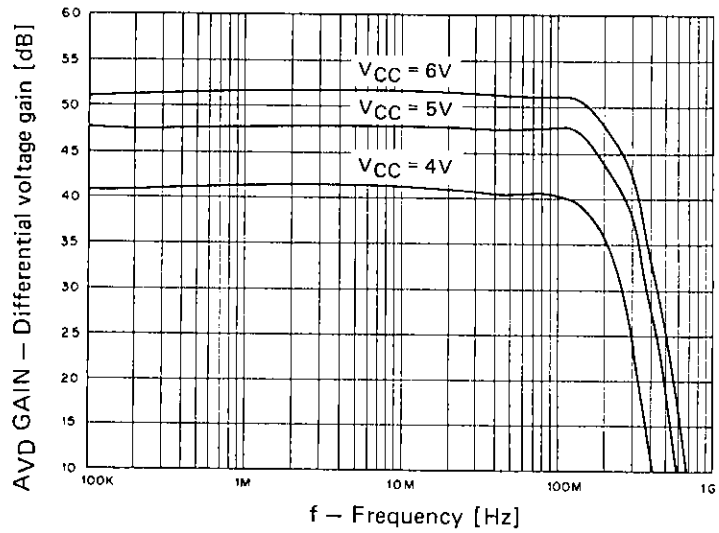

Temperature dependability of frequency characteristics

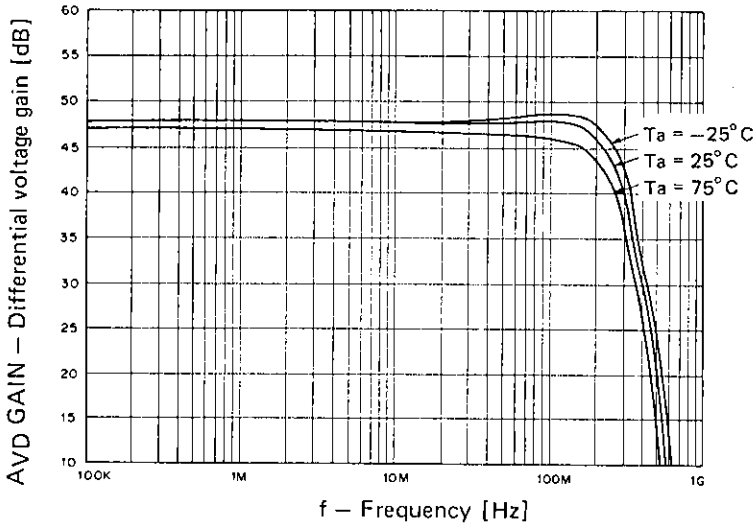

Output voltage swing vs. Supply voltage

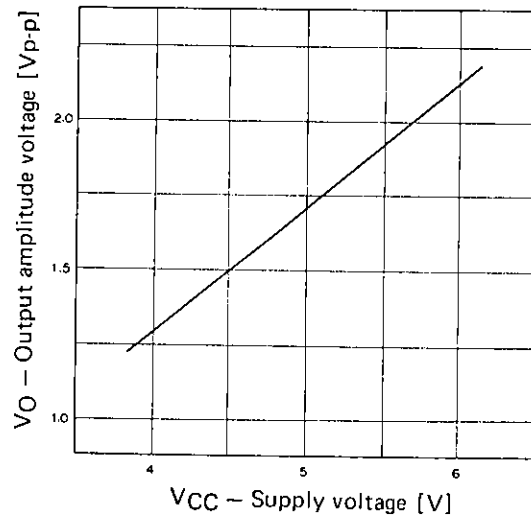

Switching Characteristics

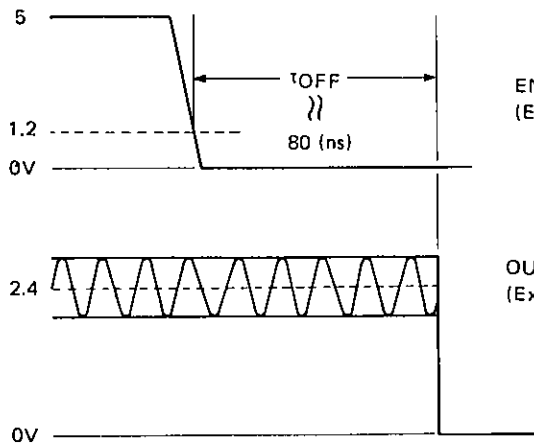
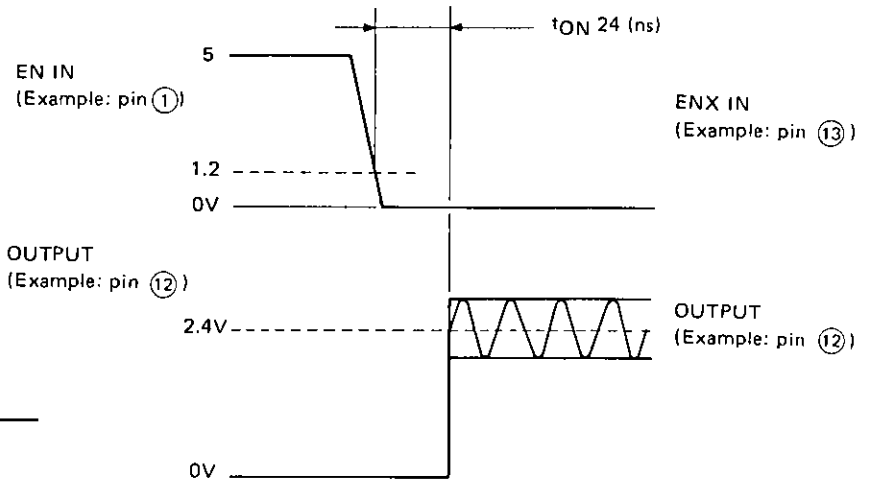
(a) Switching time t_{OFF} (b) Switching time t_{ON}