

**SONY****CXA3328TN/EN****Analog Signal Processor RX-IF IC for W-CDMA Cellular Phones****Description**

The CXA3328TN/EN is an analog signal processor RX-IF IC for W-CDMA cellular phones. This IC contains a gain control amplifier and quadrature demodulator.

**Features**

- Wide gain control range
- Linear gain slope
- Wide band (100 to 600MHz)
- Small package
  - 16-pin TSSOP (CXA3328TN)
  - 16-pin VSON (CXA3328EN)
- Low voltage operation (2.7 to 3.3V)

**Absolute Maximum Ratings**

|                         |           |             |    |
|-------------------------|-----------|-------------|----|
| • Supply voltage        | $V_{CC}$  | -0.3 to 5.5 | V  |
| • Operating temperature | $T_{opr}$ | -55 to +125 | °C |
| • Storage temperature   | $T_{stg}$ | -65 to +150 | °C |

**Operating Conditions**

|                         |          |            |    |
|-------------------------|----------|------------|----|
| • Supply voltage        | $V_{CC}$ | 2.7 to 3.3 | V  |
| • Operating temperature | $T_a$    | -25 to +85 | °C |

**Structure**

Bipolar silicon monolithic IC

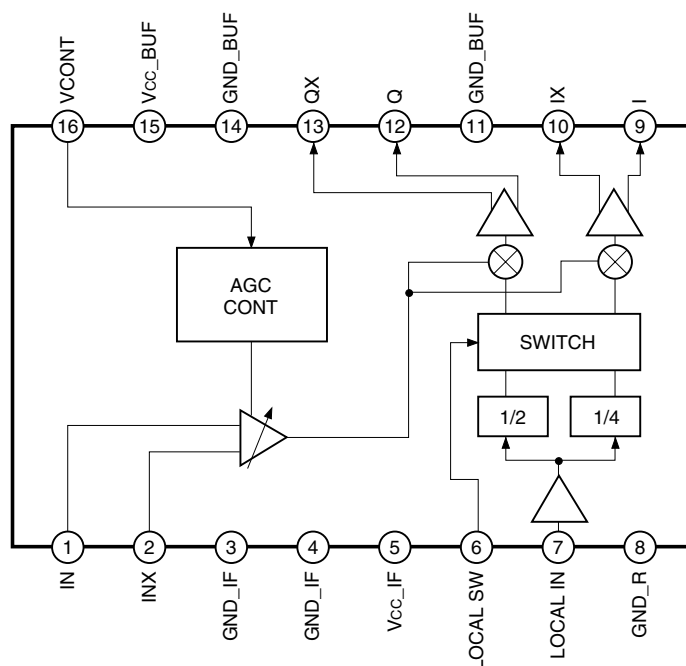
**Block Diagram**

Sony reserves the right to change products and specifications without prior notice. This information does not convey any license by any implication or otherwise under any patents or other right. Application circuits shown, if any, are typical examples illustrating the operation of the devices. Sony cannot assume responsibility for any problems arising out of the use of these circuits.

Pin Description

| Pin No.       | Symbol       | Typical pin voltage [V] | Equivalent Circuit | Pin Description  |
|---------------|--------------|-------------------------|--------------------|--|
| 1, 2          | IN, INX      | 2.85                    |                    | IF differential input.   |
| 3, 4          | GND_IF       | 0                       |                    | GCA, quadrature demodulator block ground.  |
| 5             | Vcc_IF       | 2.85                    |                    | GCA, quadrature demodulator block Vcc.   |
| 6             | LOCAL SW     | —                       |                    | Local frequency division ratio setting.<br>High: 1/4 frequency division<br>Low: 1/2 frequency division |
| 7             | LOCAL IN     | —                       |                    | Local input.   |
| 8             | GND_R        | 0                       |                    | Local signal GND.  |
| 9, 10, 12, 13 | I, IX, Q, QX | 1.5                     |                    | Baseband I, Q outputs.   |

| Pin No. | Symbol  | Typical pin voltage [V] | Equivalent Circuit | Pin Description             |
|---------|---------|-------------------------|--------------------|-----------------------------|
| 11, 14  | GND_BUF | 0                       |                    | Output buffer block ground. |
| 15      | Vcc_BUF | 2.85                    |                    | Output buffer block Vcc.    |
| 16      | VCONT   | —                       |                    | Gain control voltage input. |

**Electrical Characteristics**

**Current Consumption**

(V<sub>CC</sub> = 2.85V, Ta = 27°C)

| Item                | Symbol          | Conditions               | Measurement circuit | Measurement point | Min. | Typ. | Max. | Unit |
|---------------------|-----------------|--------------------------|---------------------|-------------------|------|------|------|------|
| Current Consumption | I <sub>CC</sub> | V <sub>cont</sub> = 1.3V | 1                   | A                 | 8    | 11   | 15   | mA   |

**I/O Resistance**

(V<sub>CC</sub> = 2.85V, Ta = 27°C)

| Item                                | Symbol           | Conditions                                  | Measurement circuit | Measurement point | Min. | Typ. | Max. | Unit |
|-------------------------------------|------------------|---|---------------------|-------------------|------|------|------|------|
| Input resistance VCONT pin          | R <sub>IVC</sub> | DC measurement:<br>V <sub>IN</sub> = 2.85V  | 1                   | B                 | 10   | —    | —    | kΩ   |
| LO input resistance                 | R <sub>ILO</sub> | DC measurement:<br>I <sub>IN</sub> = 2mA    | 1                   | C                 | 37.5 | 50   | 62.5 | Ω    |
| Output resistance I, IX, Q, QX pins | Z <sub>OUT</sub> | DC measurement:<br>I <sub>OUT</sub> = 100μA | 1                   | D, E<br>F, G      | 80   | 250  | 550  | Ω    |

**IF I/O Resistance (Design Values)**

(V<sub>CC</sub> = 2.85V, Ta = 27°C)

| Item                 | Symbol           | Conditions                                  | Min. | Typ. | Max. | Unit |
|----------------------|------------------|---|------|------|------|------|
| IF input resistance  | R <sub>IIF</sub> | Differential between Pins 1 and 2<br>380MHz | —    | 2.6  | —    | kΩ   |
| IF input capacitance | C <sub>IIF</sub> | Differential between Pins 1 and 2<br>380MHz | —    | 2    | —    | pF   |

**Input Conditions**

(V<sub>CC</sub> = 2.85V, Ta = 27°C)

| Item                 | Symbol             | Conditions     | Min. | Typ. | Max. | Unit |
|----------------------|--------------------|----------------|------|------|------|------|
| IF input frequency 1 | F <sub>RXIF1</sub> | LOCAL SW = "L" | —    | 380  | —    | MHz  |
| IF input frequency 2 | F <sub>RXIF2</sub> | LOCAL SW = "H" | —    | 190  | —    | MHz  |
| LO input frequency   | F <sub>LO</sub>    |                | —    | 760  | —    | MHz  |
| LO input level       | V <sub>LO</sub>    |                | -18  | -15  | -12  | dBm  |

## GCA Block

(V<sub>CC</sub> = 2.85V, T<sub>a</sub> = 27°C)

| Item                                 | Symbol           | Conditions   | Measurement circuit | Measurement point | Min.  | Typ.  | Max.  | Unit |
|--------------------------------------|------------------|--|---------------------|-------------------|-------|-------|-------|------|
| Input conversion noise figure        | NF               | Gain = +65dB   | 3                   | A, B<br>C, D      | —     | —     | 10    | dB   |
| Input conversion 3rd intercept point | IIP3_1           | Gain = +65dB<br>F <sub>RXIF</sub> = 382MHz<br>F <sub>LO</sub> = 760MHz<br>LOCAL SW = "L"   | 2                   | A, B<br>C, D      | -58   | —     | —     | dBm  |
|                                      | IIP3_2           | Gain = -10dB<br>F <sub>RXIF</sub> = 382MHz<br>F <sub>LO</sub> = 760MHz<br>LOCAL SW = "L"   | 2                   | A, B<br>C, D      | -10   | —     | —     | dBm  |
| Gain flatness                        | G <sub>F</sub>   | F <sub>RXIF</sub> = 382 ± 2.5MHz<br>LOCAL SW = "L"<br>F <sub>LO</sub> = 2 × (F <sub>RXIF</sub> + 2) MHz                                  | 2                   | A, B<br>C, D      | -0.25 | —     | 0.25  | dB   |
| Minimum gain                         | G <sub>MIN</sub> | V <sub>cont</sub> = 0.3 [V],<br>30mVp-p differential output<br>F <sub>RXIF</sub> = 382MHz<br>F <sub>LO</sub> = 760MHz<br>LOCAL SW = "L"  | 2                   | A, B<br>C, D      | —     | -25.5 | -20.5 | dB   |
| Maximum gain                         | G <sub>MAX</sub> | V <sub>cont</sub> = 2.3 [V],<br>100mVp-p differential output<br>F <sub>RXIF</sub> = 382MHz<br>F <sub>LO</sub> = 760MHz<br>LOCAL SW = "L" | 2                   | A, B<br>C, D      | 67.5  | 72.5  | —     | dB   |
| Gain temperature error               | G <sub>ERR</sub> | T <sub>a</sub> = -25 to +85°C  | 2                   | A, B<br>C, D      | -4    | —     | 4     | dB   |

**Quadrature Demodulator Block**(V<sub>CC</sub> = 2.85V, T<sub>a</sub> = 27°C)

| Item                         | Symbol            | Conditions   | Measurement circuit | Measurement point | Min. | Typ. | Max. | Unit  |
|------------------------------|-------------------|--|---------------------|-------------------|------|------|------|-------|
| I/Q maximum output amplitude | V <sub>MAX</sub>  | R <sub>L</sub> = 10kΩ, C <sub>L</sub> = 10pF<br>F <sub>RXIF</sub> = 382MHz<br>F <sub>LO</sub> = 760MHz<br>LOCAL SW = "L" | 2                   | A, B<br>C, D      | 500  | —    | —    | mVp-p |
| I/Q output band width        | V <sub>BW</sub>   | -3dB band width  | 2                   | A, B<br>C, D      | 5    | 13   | —    | MHz   |
| I/Q phase error              | P <sub>ERR</sub>  | F <sub>RXIF</sub> = 382MHz<br>F <sub>LO</sub> = 760MHz<br>LOCAL SW = "L"   | 2                   | A, B<br>C, D      | -4   | —    | 4    | deg   |
| I/Q output amplitude balance | V <sub>BL</sub>   | F <sub>RXIF</sub> = 382MHz<br>F <sub>LO</sub> = 760MHz<br>LOCAL SW = "L"   | 2                   | A, B<br>C, D      | -1.5 | —    | 1.5  | dB    |
| I-IX/Q-QX DC offset          | V <sub>OFST</sub> | DC measurement   | 2                   | A, B<br>C, D      | -200 | —    | 200  | mV    |

**Local Frequency Division Ratio**

| LOCAL SW (Pin 6) | Frequency division ratio |
|------------------|--------------------------|
| L                | 1/2                      |
| H                | 1/4                      |

Electrical Characteristics Measurement Circuit 1

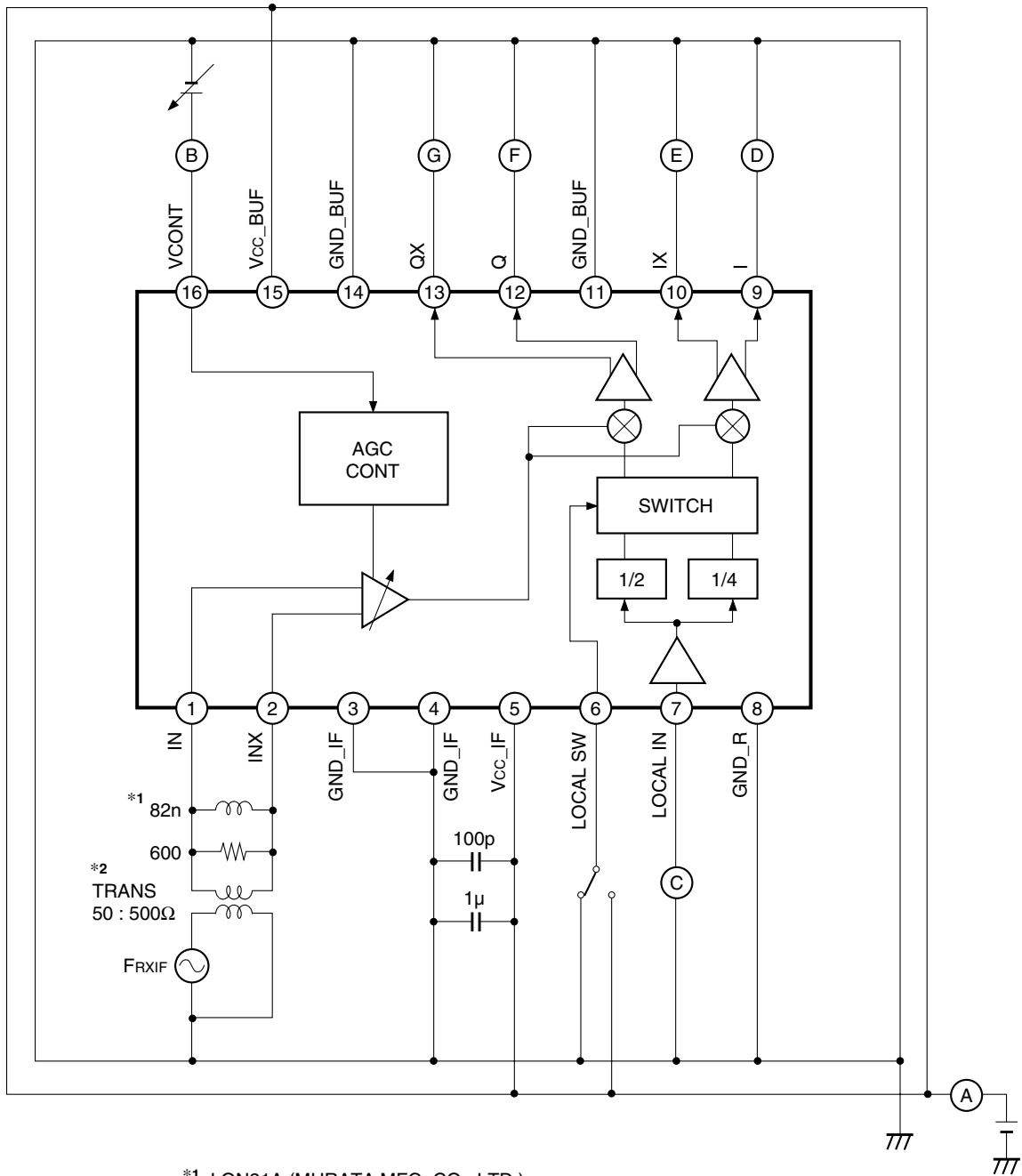

\*1 LQN21A (MURATA MFG. CO., LTD.)  
 \*2 616DS-1135 (TOKO, Inc.)

Electrical Characteristics Measurement Circuit 2

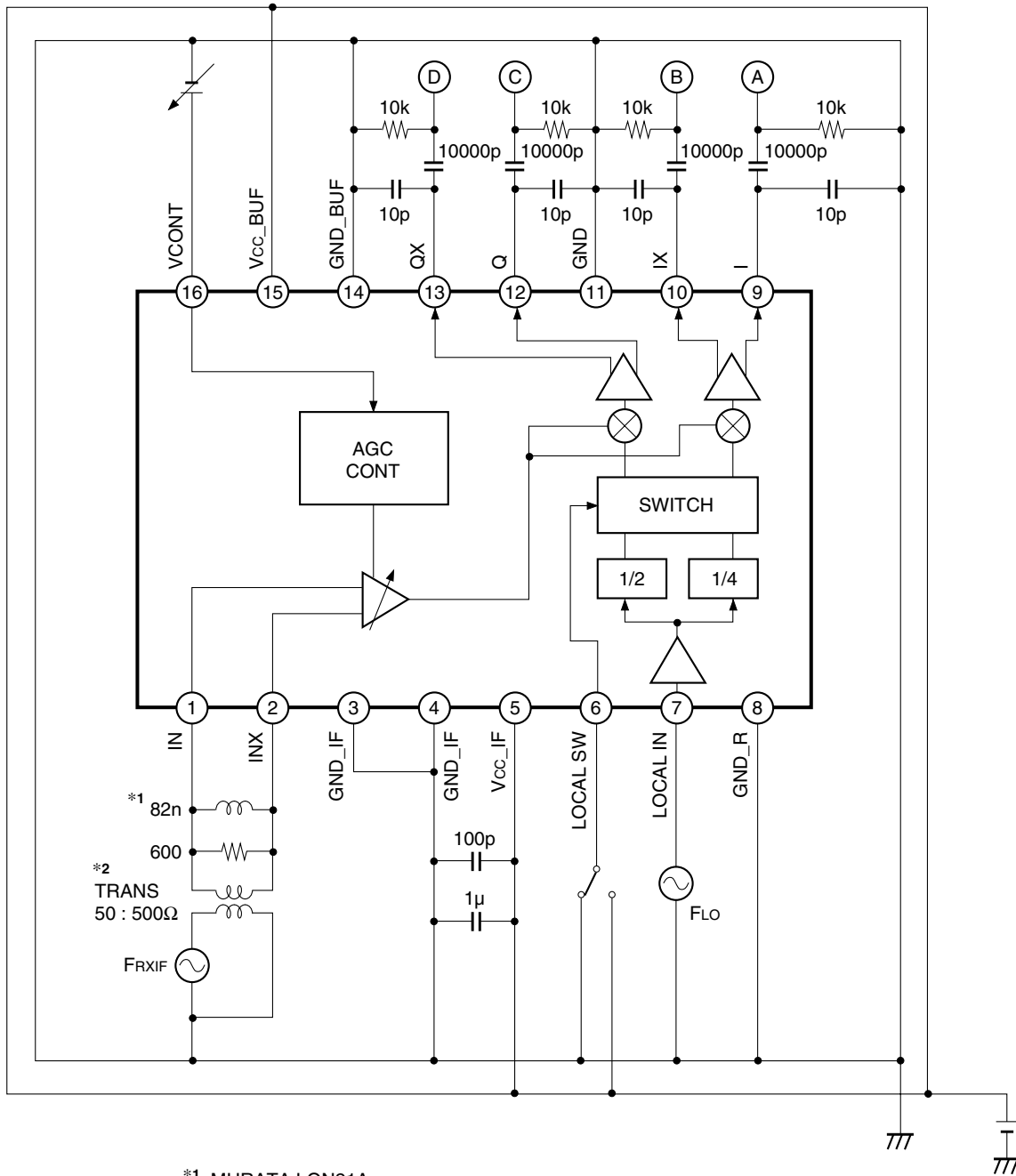

\*1 MURATA LQN21A  
 \*2 TOKO 616DS-1135



Electrical Characteristics Measurement Circuit 3

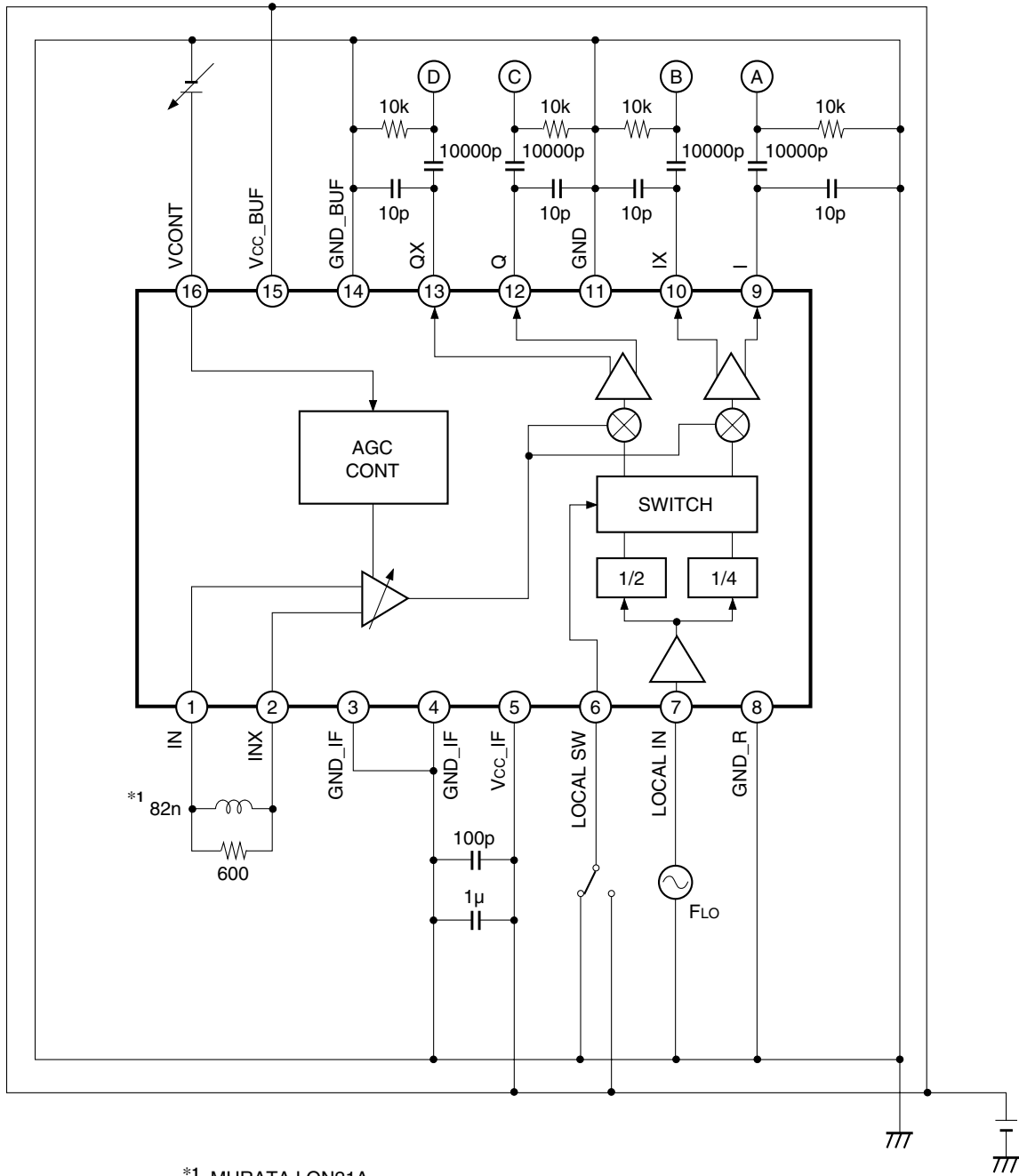

\*1 MURATA LQN21A

Application Circuit

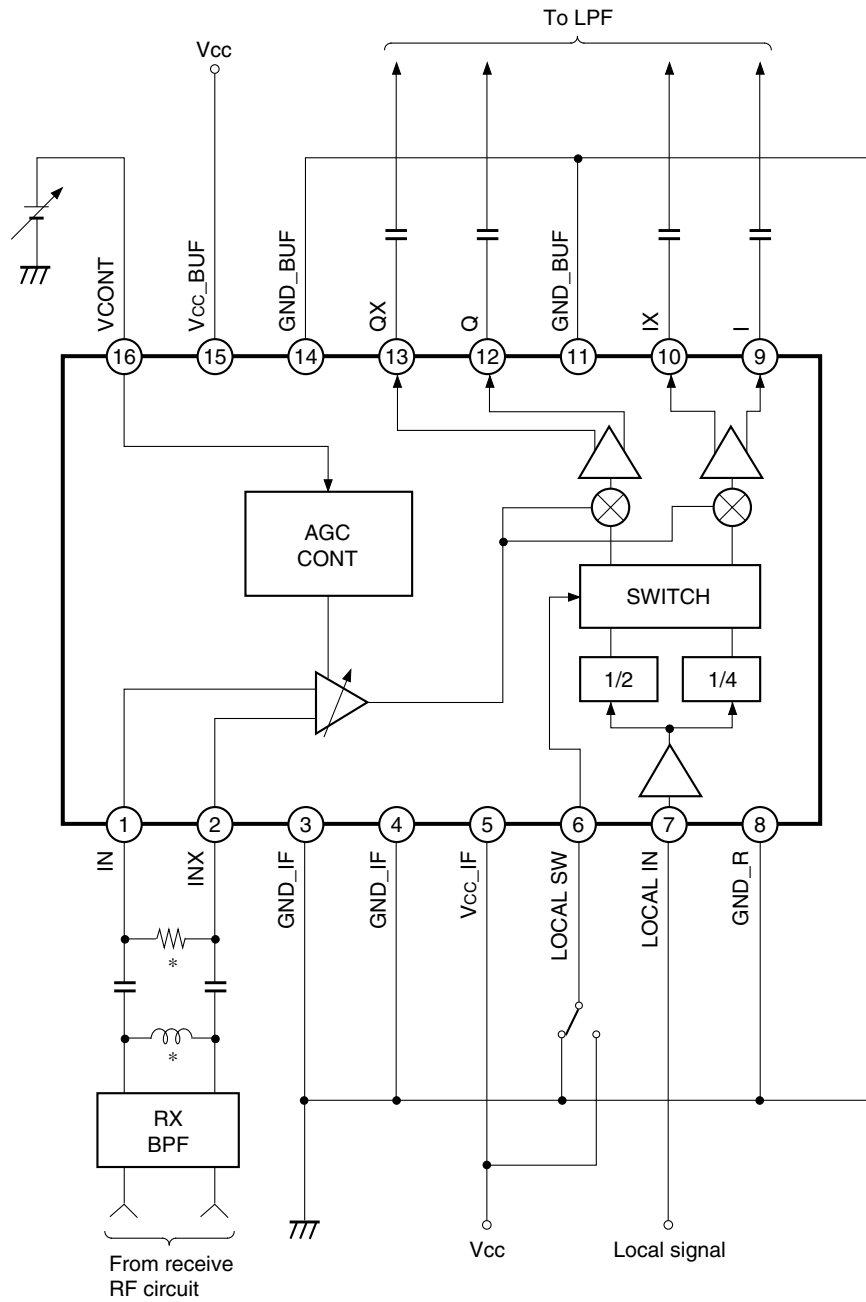

\* Adjust this value so that the impedance matching with this IC is optimum.

Application circuits shown are typical examples illustrating the operation of the devices. Sony cannot assume responsibility for any problems arising out of the use of these circuits or for any infringement of third party patent and other right due to same.

**Description of Operation**

**1. Outline of Operation**

This IC performs the signal processing between the analog transmit baseband processing block and the analog transmit RF processing block of the cellular phone. The figure below shows the general circuit block diagram for the portable cellular phone using this IC. The input of this IC is connected to the analog RF processing block; the output is connected to the baseband signal processing block.

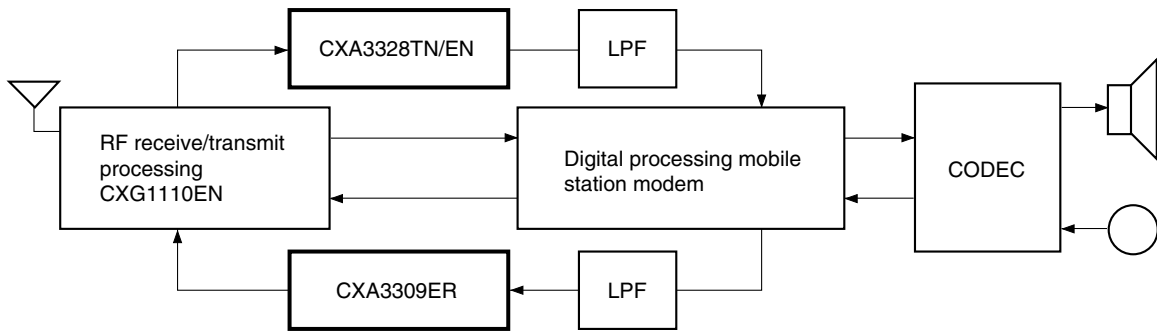

**2. IC Internal Signal Flow**

An IF signal and a local signal are input to this IC as shown in the figure below. The IF signal is gain-controlled to the necessary level by the gain control amplifier and is input to the quadrature demodulator block. The local signal is 1/2 or 1/4 frequency-divided. Also, that signal becomes the quadrature I/Q local signal via the FF phase shifter and quadrature-demodulated with the IF signal to become the baseband signal.

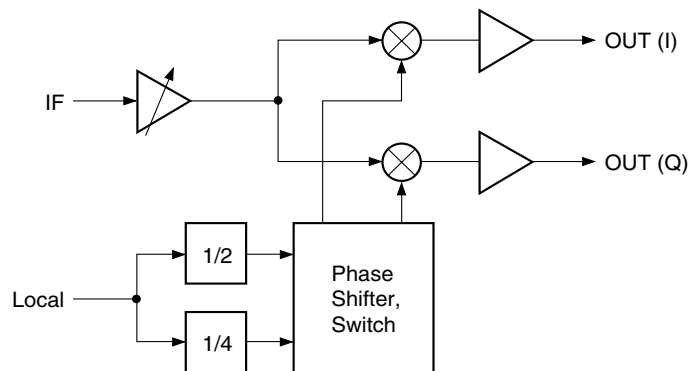

## Notes on Operation

### 1. IF Input

The IF signal is differentially input to the IN pin and INX pin of this IC. IF is input to the input pin by AC coupling. The value of the AC coupling is selected so that the transfer power from the receive RF circuit is maximum.

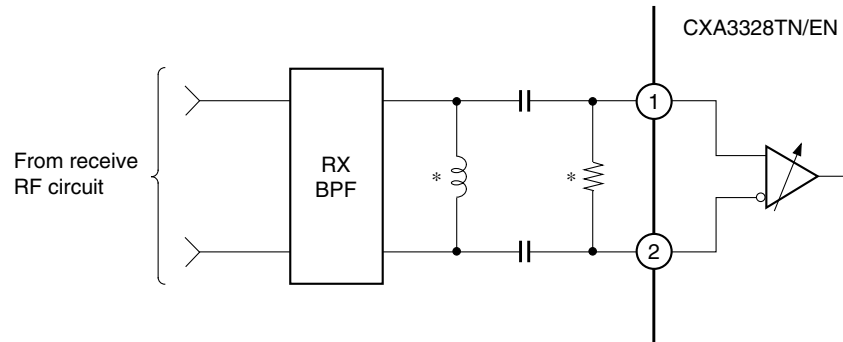

\* This value must be the value taken for the optimum impedance matching between the BPF filter and this IC.

### 2. Notes on Power Supplies

The CXA3328TN/EN is designed to operate by a 2.85V stabilized power supply to allow use with the battery driven portable phones. Using multiple voltage regulators throughout the phone is recommended to minimize the power supply noise in the CXA3328TN/EN power supply input. The recommended power supply range for the CXA3328TN/EN is 2.7 to 3.3V. Decouple the power supplies around the CXA3328TN/EN using 1 $\mu$ F capacitor for each Vcc pin. Locate this capacitor as close to the pins as possible, and minimize the series inductance for the pin connections. Using an additional 1nF decoupling capacitor in parallel to the 1 $\mu$ F capacitor is recommended to further reduce the high frequency noise in the power supply input to the CXA3328TN/EN.

Example of Representative Characteristics

Voltage gain vs. Control voltage Vcont

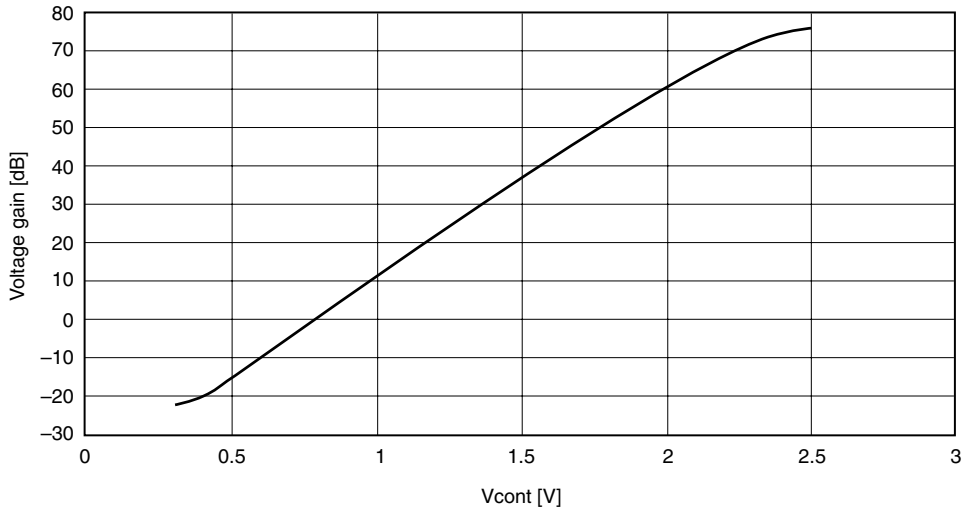

Noise figure vs. Voltage gain

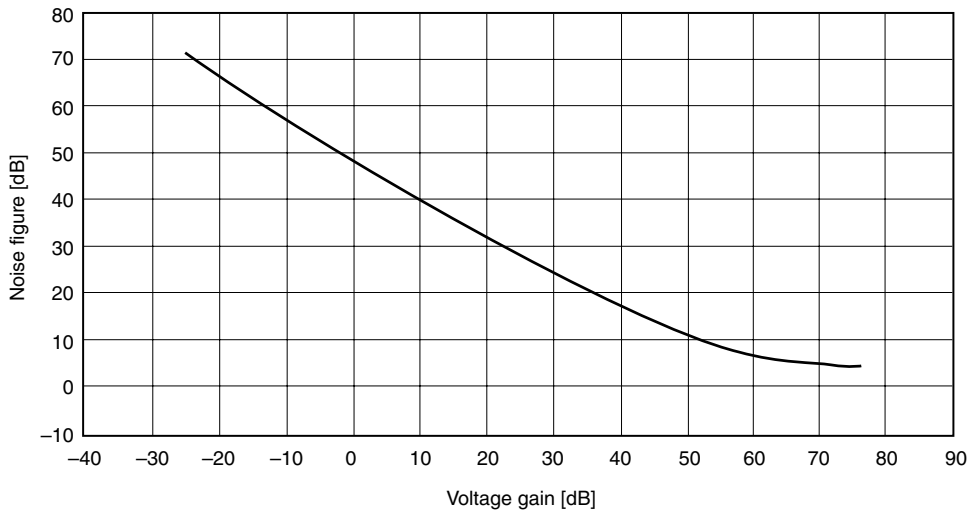

IIP3 vs. Voltage gain

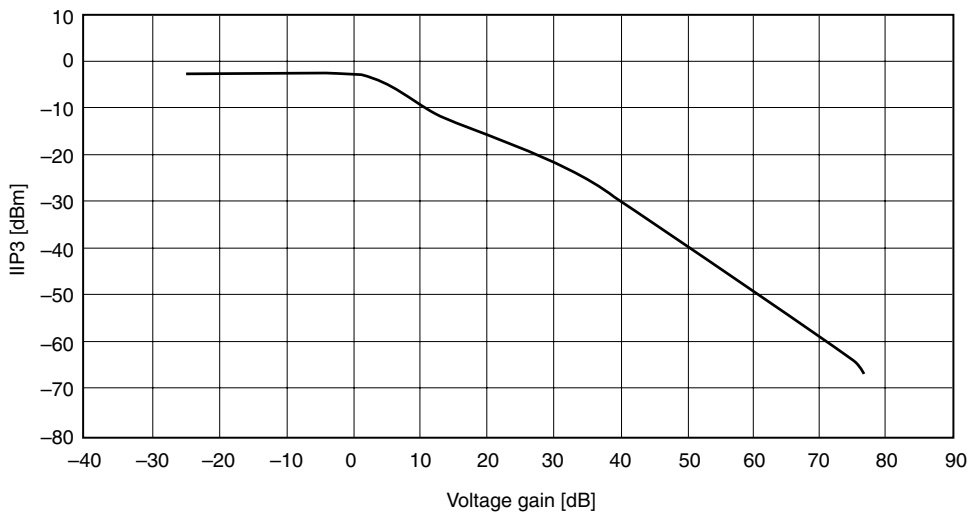

Package Outline

Unit: mm

CXA3328TN

16PIN TSSOP (PLASTIC)

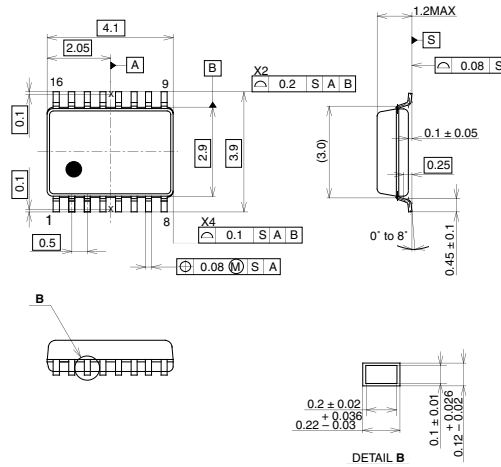

|            |               |
|------------|---------------|
| SONY CODE  | TSSOP-16P-L01 |
| EIAJ CODE  | _____         |
| JEDEC CODE | _____         |

| PACKAGE STRUCTURE |                |
|-------------------|----------------|
| PACKAGE MATERIAL  | EPOXY RESIN    |
| LEAD TREATMENT    | SOLDER PLATING |
| LEAD MATERIAL     | COPPER ALLOY   |
| PACKAGE MASS      | 0.03g          |

SCT & Kokubu Ass'y

16PIN TSSOP (PLASTIC)

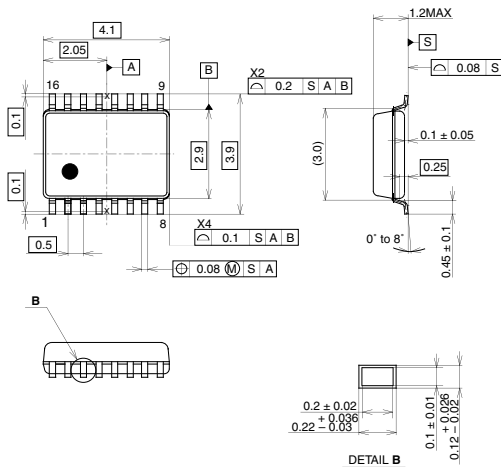

|            |               |
|------------|---------------|
| SONY CODE  | TSSOP-16P-L01 |
| EIAJ CODE  | _____         |
| JEDEC CODE | _____         |

| PACKAGE STRUCTURE |                |
|-------------------|----------------|
| PACKAGE MATERIAL  | EPOXY RESIN    |
| LEAD TREATMENT    | SOLDER PLATING |
| LEAD MATERIAL     | COPPER ALLOY   |
| PACKAGE MASS      | 0.03g          |

LEAD PLATING SPECIFICATIONS

| ITEM               | SPEC.           |
|--------------------|-----------------|
| LEAD MATERIAL      | COPPER ALLOY    |
| SOLDER COMPOSITION | Sn-Bi Bi:1-4wt% |
| PLATING THICKNESS  | 5-18µm          |

Package Outline  
CXA3328EN

Unit: mm

16PIN VSON (PLASTIC)

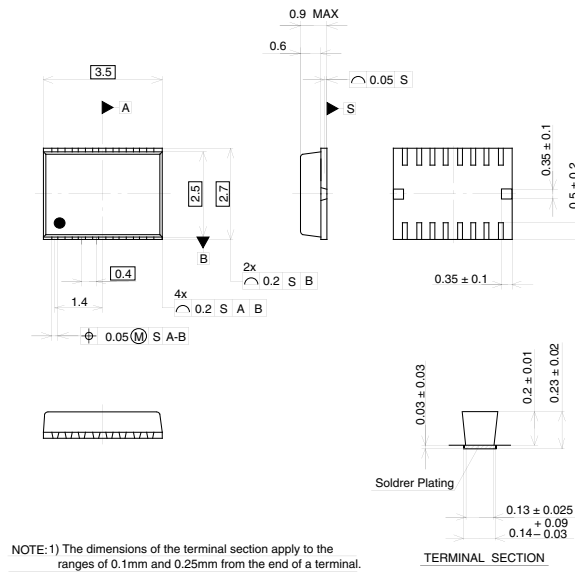

NOTE: 1) The dimensions of the terminal section apply to the ranges of 0.1mm and 0.25mm from the end of a terminal.

PACKAGE STRUCTURE

|            |             |
|------------|-------------|
| SONY CODE  | VSON-16P-01 |
| EIAJ CODE  |             |
| JEDEC CODE |             |

|                  |                |
|------------------|----------------|
| PACKAGE MATERIAL | EPOXY RESIN    |
| LEAD TREATMENT   | SOLDER PLATING |
| LEAD MATERIAL    | COPPER ALLOY   |
| PACKAGE MASS     | 0.02 g         |

SCT & Kokubu Ass'y

16PIN VSON (PLASTIC)

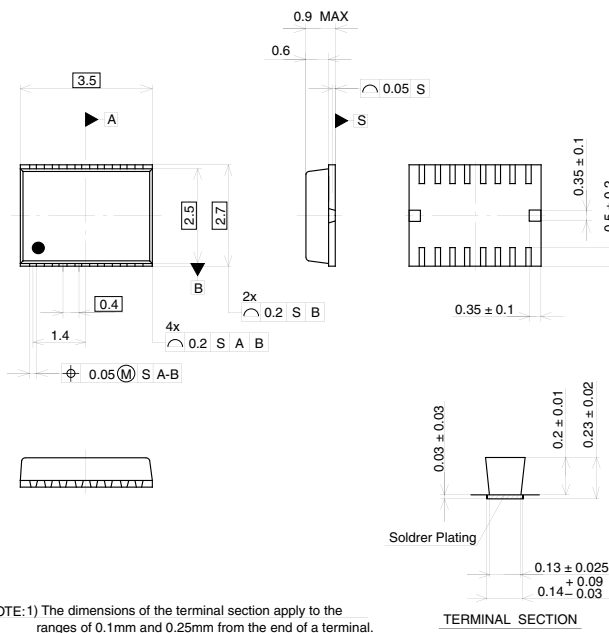

NOTE: 1) The dimensions of the terminal section apply to the ranges of 0.1mm and 0.25mm from the end of a terminal.

PACKAGE STRUCTURE

|            |             |
|------------|-------------|
| SONY CODE  | VSON-16P-01 |
| EIAJ CODE  |             |
| JEDEC CODE |             |

|                  |                |
|------------------|----------------|
| PACKAGE MATERIAL | EPOXY RESIN    |
| LEAD TREATMENT   | SOLDER PLATING |
| LEAD MATERIAL    | COPPER ALLOY   |
| PACKAGE MASS     | 0.02 g         |

LEAD PLATING SPECIFICATIONS

|                    |                 |
|--------------------|-----------------|
| ITEM               | SPEC.           |
| LEAD MATERIAL      | COPPER ALLOY    |
| SOLDER COMPOSITION | Sn-Bi Bi:1-4wt% |
| PLATING THICKNESS  | 5-18µm          |