Description

The CXA3822M is a secondary controller IC used for AC-DC power supply series resonance converter.
(Applications: Power supply circuits)

Features

< 5V, 12V control block >

- ◆ 5V/12V voltage control circuit
- ◆ OTP (Detection of abnormal temperature) function
- ◆ LVP/OVP (Detection of abnormal voltage)
- ◆ Mode transition timer function

< Common >

- ◆ 16-pin SOP package
- ◆ TSD protection function
- ◆ UVLO function

Structure

CMOS silicon monolithic IC

Sony reserves the right to change products and specifications without prior notice. This information does not convey any license by any implication or otherwise under any patents or other right. Application circuits shown, if any, are typical examples illustrating the operation of the devices. Sony cannot assume responsibility for any problems arising out of the use of these circuits.

Absolute Maximum Ratings

Item	Symbol	Rating	Unit	Remarks
Maximum supply voltage1	VCC_12V	24	V	VIN5, VIN12
Maximum supply voltage2	VDD5	7.5	V	VDD5
12V pin voltage	VCCIN	-0.3 to +24	V	AMPO12, AMPIN12, AMPO5, AMPIN5
VDD pin voltage	VDDIN	-0.3 to +7.5	V	TEST, TEMP, xACDC_STBY, xPFCOK, xACDET, MAINON, LATCH5, ACIN_DET
Allowable power dissipation	Pd	*1	mW	(See the thermal derating curve.)
Operating ambient temperature range	Topt	-30 to +125	°C	—
Junction temperature	Tjmax	+150	°C	—
Storage temperature	Tstg	-55 to +150	°C	—

*1 Allowable power dissipation reduction characteristics

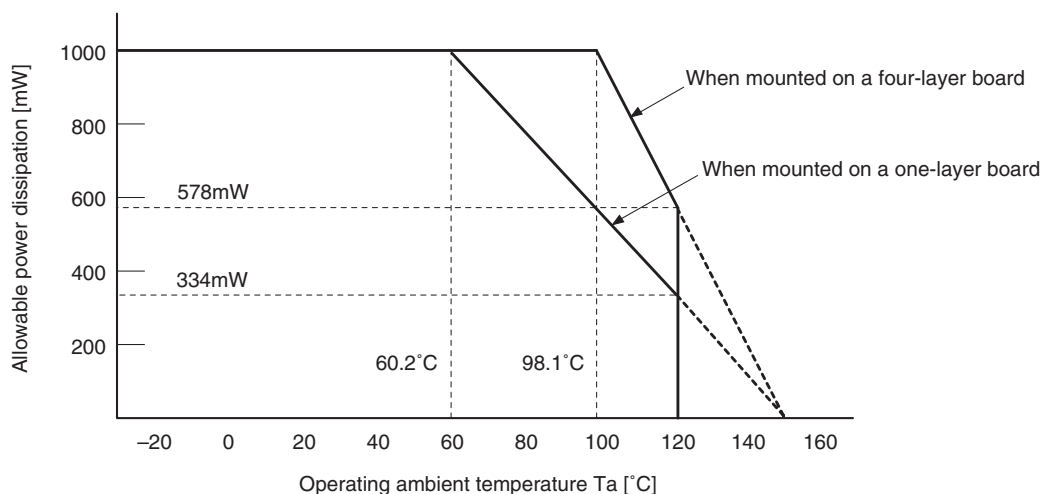

Glass fabric base epoxy board, 76mm × 114mm, t = 1.6mm

Recommended Operating Conditions

Item	Symbol	Rating	Unit	Remarks
Supply voltage1	VCC_12V	7.6 to 14.79	V	Protection function operates outside of VIN12 rating.
Supply voltage2	VCC_5V	3.8 to 6.12	V	Protection function operates outside of VIN5 rating.
Supply voltage3	VDD5	4.0 to 6.0	V	VDD5
Operating ambient temperature range	Topt	-25 to +85	°C	—
Junction temperature	Tj	-25 to +125	°C	—

Block Diagram

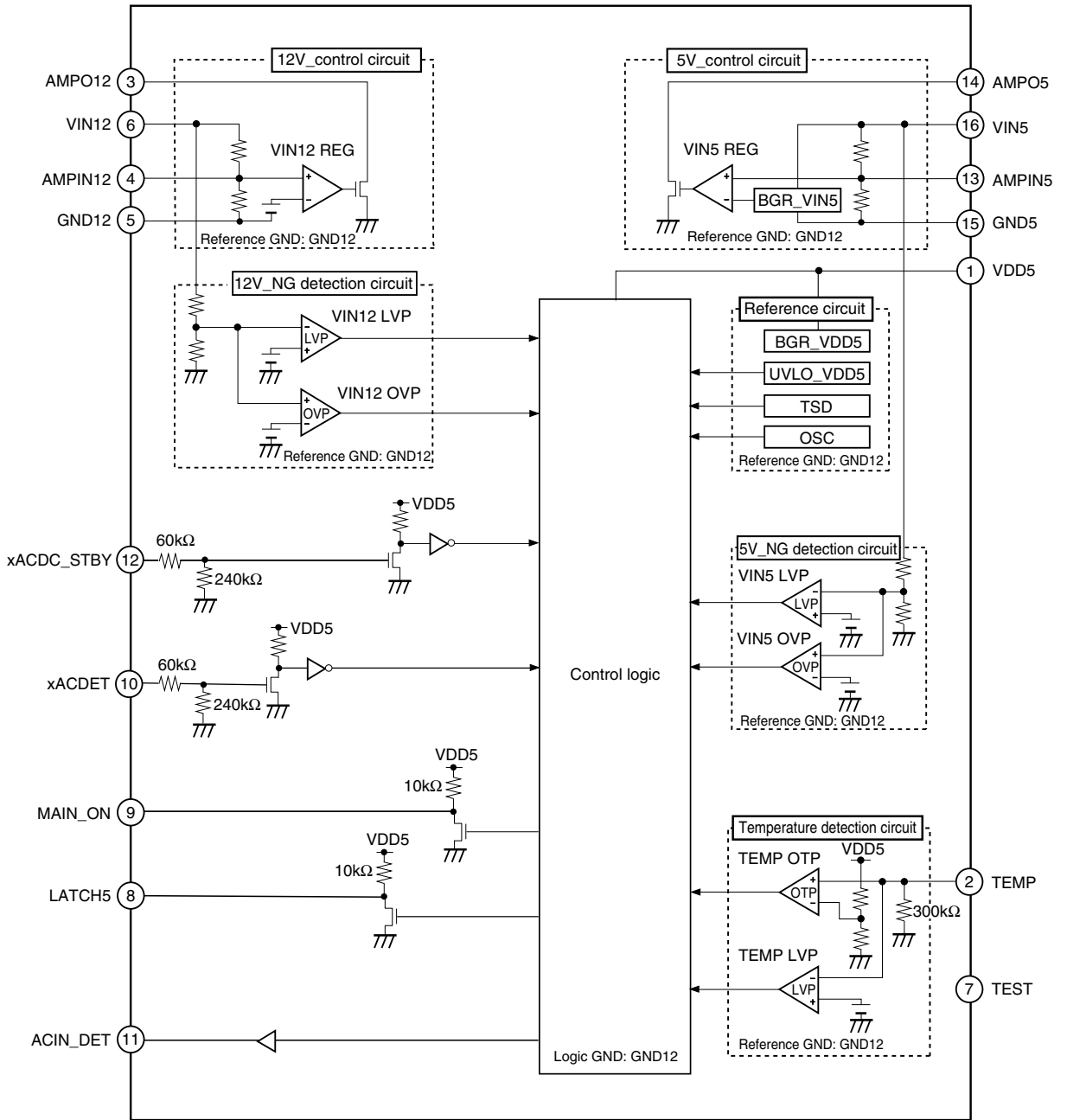

Pin Configuration

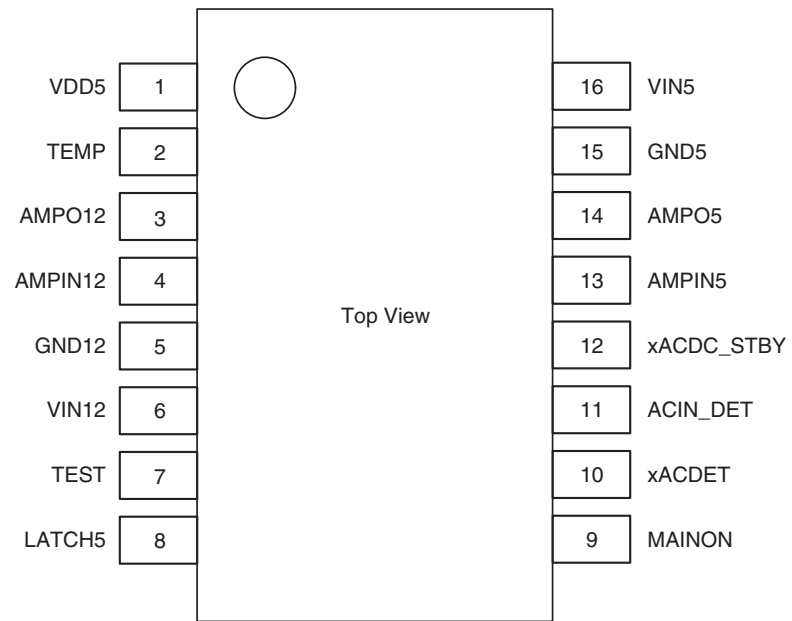

Pin Table

Pin No.	Pin name	IN/OUT	Function
1	VDD5	—	V _{DD} power supply output
2	TEMP	IN	Temperature monitor input for overheat protection
3	AMPO12	OUT	12V control output
4	AMPIN12	IN	12V control input
5	GND12	—	12V control GND, Internal reference GND, Logic GND
6	VIN12	—	12V input
7	TEST	—	NC
8	LATCH5	OUT	Signal for latch stop of 5V output
9	MAINON	OUT	Power supply main 12V output ON/OFF signal
10	xACDET	IN	AC/+B detection signal from power supply upstream
11	ACIN_DET	OUT	AC detection signal
12	xACDC_STBY	IN	ON/standby switching signal for power supply (12V)
13	AMPIN5	IN	5V control input
14	AMPO5	OUT	5V control output
15	GND5	—	GND for 5V control
16	VIN5	—	5V input

Input logic

Input signal	L	H
xACDC_STBY	Standby mode (12V = OFF)	Operating mode (12V = ON)
xACDET	No upstream AC	Upstream AC

Output logic

Output signal	L	H
MAINON	Main output ON	Main output OFF
ACIN_DET	Abnormal (No AC)	Normal (AC)
LATCH5	Abnormal (5V off latch)	Normal

Pin Description

Pin No.	Symbol	I/O	Standard pin voltage	Equivalent circuit	Description
1	VDD5	—	—	—	VDD power supply input
2	TEMP	I	GND to VDD5		Temperature monitor input for overheat protection
3	AMPO12	O	GND to VIN12		12V control output
4	AMPIN12	I	GND to VIN12		12V control input
5	GND12	—	—	—	GND for 12V control
6	VIN12	—	—	—	12V input
7	TEST	—	—	—	NC
8	LATCH5	O	GND to VDD5		Signal for latch stop of 5V output
9	MAINON				Power supply main 12V output ON/OFF signal

Pin No.	Symbol	I/O	Standard pin voltage	Equivalent circuit	Description
10	xACDET	I	GND to VDD5		AC/+B detection signal from power supply upstream
11	ACIN_DET	O	GND to VDD5		AC detection signal
12	xACDC_STBY	I	GND to VDD5		ON/standby switching signal for power supply (ACDC)
13	AMPIN5	I	GND to VIN5		5V control input
14	AMPO5	O	GND to VIN5		5V control output
15	GND5	—	—	—	GND for 5V control
16	VIN5	—	—	—	5V input

Electrical Characteristics

Circuit current

(Unless otherwise specified, the conditions are VIN5 = 5.5V, VDD5 = 5.0V, VIN12 = 12V, Ta = 25°C)

Item	Symbol	Conditions	Min.	Typ.	Max.	Unit
Standby current	ISTBY1	Power supply: VIN5, VDD5 xACDC_STBY = L (12V = OFF)	—	0.7	1.0	mA
Operating current1	ICC1	Power supply: VIN5, VDD5 xACDC_STBY = H (12V = ON)	—	1.7	3.0	mA
Operating current2	ICC2	Power supply: VIN12 xACDC_STBY = H (12V = ON)	—	0.2	0.4	mA

Note) Co indicates capacitance connected to OUT pin.

Logic pin

(Unless otherwise specified, the conditions are VIN5 = 5.5V, VDD5 = 5.0V, VIN12 = 12V, Ta = 25°C)

Item	Symbol	Conditions	Min.	Typ.	Max.	Unit
Logic pin Input High voltage	VIH	xACDC_STBY, xACDET pin	2.0	—	VDD	V
Logic pin Input Low voltage	VIL	xACDC_STBY, xACDET pin	0	—	0.5	V
Logic input Inflow current1	IIN1	xACDC_STB, xACDET pin VIN = 5V	10	17	25	μA
Logic output High voltage	VOH	ACIN_DET, Io = -5mA	VDD - 0.3	—	VDD	V
Logic output Low voltage	VOL	ACIN_DET, Io = 5mA	0	—	0.3	V
Output voltage during Low (Open drain pin)	VLI	Io = 5mA MAINON, LATCH5 pin	—	—	0.3	V
Logic output High side on resistance	ROH	ACIN_DET, Io = -5mA	0	15	60	Ω
Logic output Low side on resistance	ROL1	ACIN_DET, Io = 5mA	0	15	60	Ω
Output on resistance during Low (Open drain pin)	ROL2	Io = 5mA MAINON, LATCH5 pin	0	15	60	Ω

5V,12V control block

(Unless otherwise specified, the conditions are VIN5 = 5.5V, VDD5 = 5.0V, VIN12 = 12V, Ta = 25°C)

Item	Symbol	Conditions	Min.	Typ.	Max.	Unit
5V control voltage	V5	Voltage between VIN5 and GND5 VDD5 = 4 to 6V	5.47	5.53	5.59	V
5V input LVP detection voltage	LVP5	Voltage between VIN5 and GND5 VDD5 = 4 to 6V	3.8	4.0	4.2	V
5V input OVP detection voltage	OVP5	Voltage between VIN5 and GND5 VDD5 = 4 to 6V	5.88	6.0	6.12	V
AMPO5 output voltage during Low	VLI_5V	Io = 5mA	—	—	0.3	V
12V control voltage	V12	Voltage between VIN12 and GND12 VDD5 = 4 to 6V	11.88	12	12.12	V
12V input LVP detection voltage	LVP12	Voltage between VIN12 and GND12 VDD5 = 4 to 6V	7.6	8	8.4	V
12V input OVP detection voltage	OVP12	Voltage between VIN12 and GND12 VDD5 = 4 to 6V	14.21	14.5	14.79	V
AMPO12 output voltage during Low	VLI_12V	Io = 5mA	—	—	0.3	V
Temperature abnormality detection ratio *1	OTP	OTP = TEMP/VDD VDD5 = 4 to 6V	0.68	0.692	0.704	—
TEMP pin LVP detection	LTP	—	0.05	0.1	0.2	V
VDD5 operation start voltage	ACT_VDD	VDD5 = L → H	3.1	3.3	3.5	V
VDD5 operation stop voltage	UVLO_VDD	VDD5 = H → L	2.5	2.7	2.9	V
Hysteresis width	HYS_VDD	HYS_VDD = ACT_VDD – UVLO_VDD	0.2	0.5	1.0	V

*1 Detects temperature abnormality when TEMP/VDD5 ≥ 0.692.

Example of calculation: Detects temperature abnormality when TEMP/VDD5 = TEMP/5V ≥ 0.692,
that is TEMP ≥ 0.692 × 5 = 3.46V.

Description of Operation

1. 5V Control Circuit and 12V Control Circuit

Fig.1 shows the equivalent circuit for the 5V and 12V control block.

When the VIN5 voltage exceeds 5.5V, the internal AMP output switches and current is drawn from AMPO5. This enables control of VIN5 at 5.5V in combination with the primary side via a photocoupler connected to the AMPO5 pin.

The 12V control operates in like manner; current is drawn from the AMPO12 pin when the VIN12 voltage exceeds 12V. This enables control of VIN12 at 12V in combination with the primary side via a photocoupler connected to AMPO12.

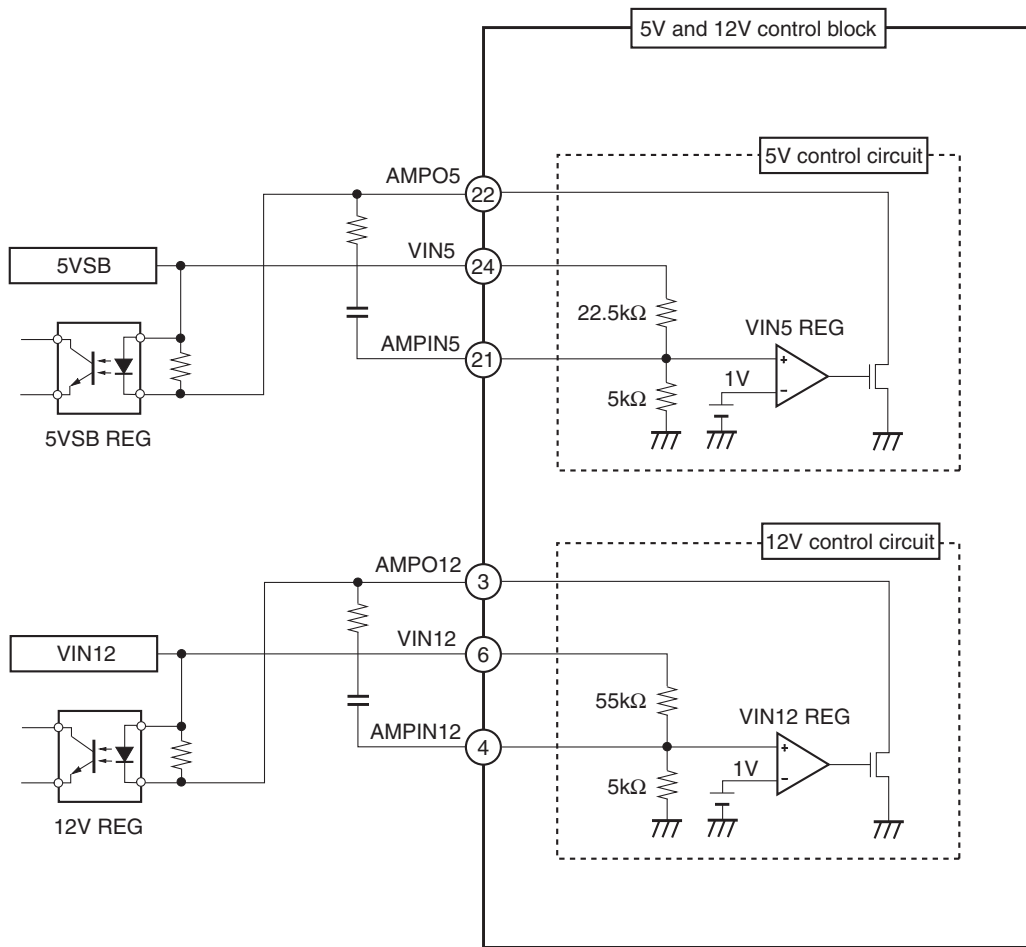

Fig.1. 5V and 12V Control Equivalent Circuit

2. 5V and 12V Control Abnormality Detection

Fig.2 shows the equivalent circuits for the 5V and 12V control voltage abnormality detection block.

When an abnormal 5V and 12V control REG voltage occurs during operation, the device detects the abnormality and transitions to the “latch stop” state. (For the states following abnormality detection, see the state transition diagram on page 19.)

The abnormality detection voltages are as follows.

5V control abnormality detection----- LVP: 4V or lower
 OVP: 6V or higher

12V control abnormality detection-----LVP: 8V or lower
 OVP: 14.5V or higher

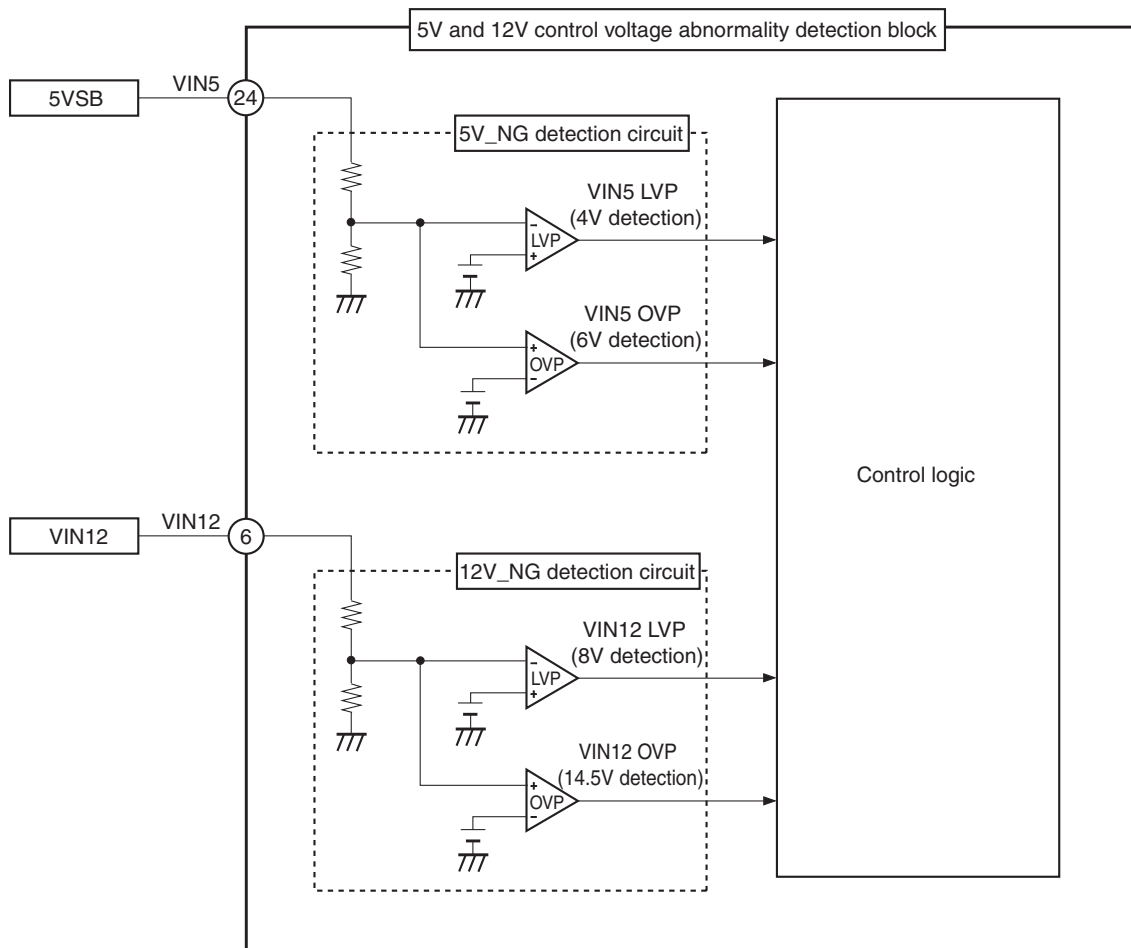

Fig.2. 5V and 12V Control Abnormality Detection Equivalent Circuit

3. Temperature Abnormality Detection Circuit

Fig.3 shows the equivalent circuit for the temperature abnormality detection block.

As shown in the figure, a thermistor connected between the TEMP and VDD5 pins enables detection of abnormal board temperatures. A temperature error is detected when the voltage ratio of the TEMP and VDD5 pins is 0.692 or more ($TEMP/VDD5 \geq 0.692$).

A temperature abnormality is defined when the abnormal temperature continues for 1.1 seconds.

When a temperature abnormality is detected, the device transitions to the “abnormality detection” or “latch stop” state.

(For the states following abnormality detection, see the state transition diagram on page 14.)

In addition, as a pin protection function, the same abnormality is detected when the voltage of the TEMP pins falls to 0.1V or lower.

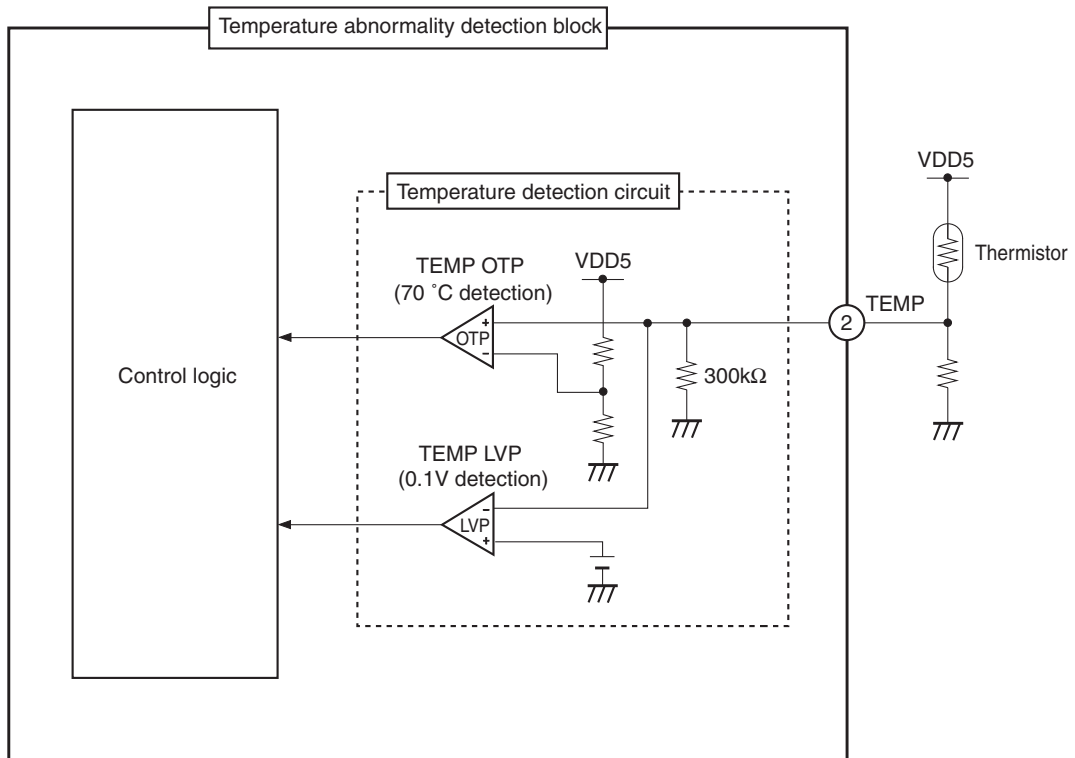

Fig.3. Temperature Abnormality Detection Equivalent Circuit

5. State Transition Diagram

Fig.4 shows a state transition diagram (main state).

Transitions between states occur in response to input signals from external sources or the condition of the 5V and 12V outputs.

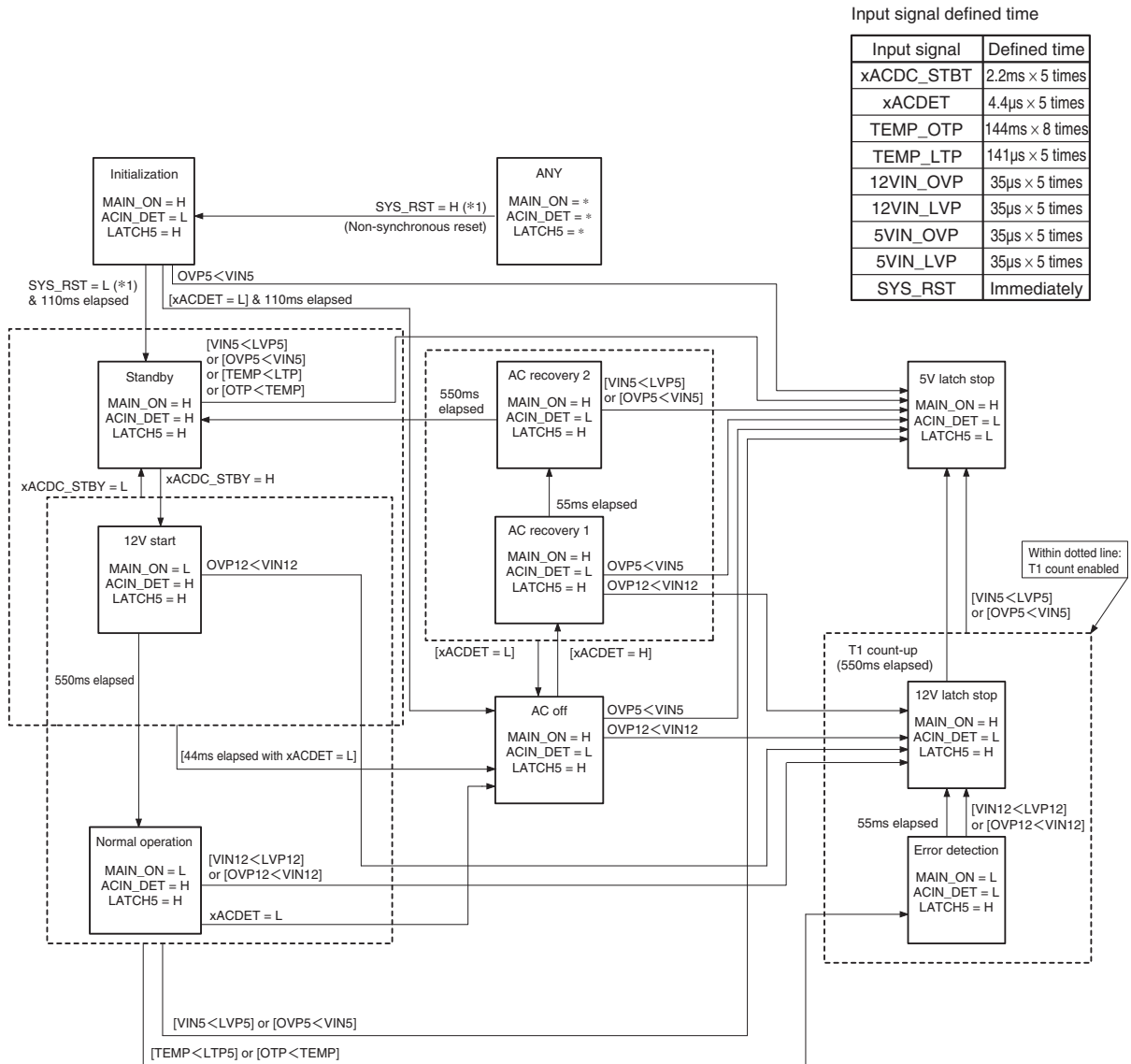

Fig.4. State Transition Diagram

Input Signal Descriptions

No.	Input signal name	Signal description
*1	SYS_RST	Reset signal based on logic power supply (VDD5 pin) High: Reset (VDD5 ≤ 2.7V), Low: Reset canceled (VDD5 ≥ 3.3V)

AC Off Timing Chart

When AC input stops while in the “standby” or “12V start” state, the device transitions to the “AC off” state after a minimum of 44ms has elapsed.

The conditions for a transition from the “standby” or “12V start” state to the “AC off” state are as follows:

Conditions for transition to “AC off”: xACDET = Low for 44ms duration

When the AC input returns within 44ms, no transition to the “AC off” state occurs and the current state is maintained.

A timing chart for the transition from “standby” to “AC off” is shown below.

Transition from "standby" or "12V start" to "AC Off"

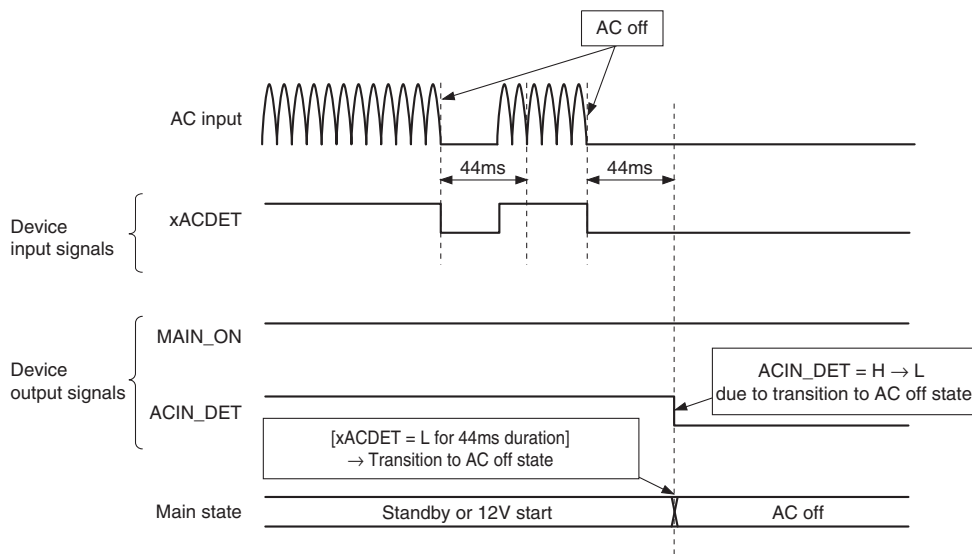

A timing chart for the transition from “normal operation” to “AC off” is shown below.

When AC input stops while in a state other than “standby” or “12V start,” the transition to the “AC off” state occurs the moment the xACDET pin goes Low, regardless of whether or not 44ms have elapsed.

Transition from "Normal Operation" to "AC Off"

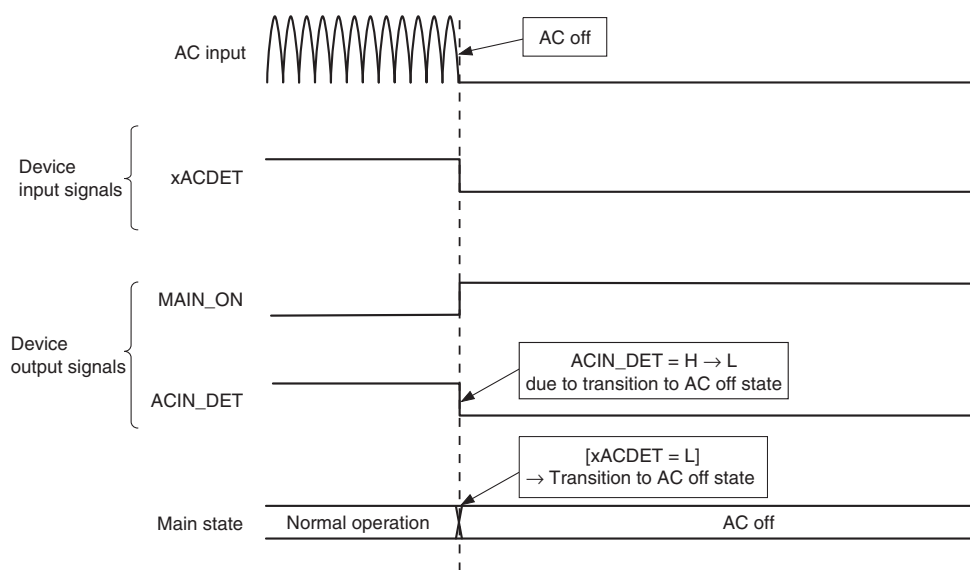

Start Timing Chart

Fig.5 shows a timing chart for the start of operation.

The device is in the “initialization” state until 110ms have elapsed after the rising edge of VIN5 and VDD5 exceeds 3.3V.

In the “initialization” state, 5V LVP detection, temperature detection, and AC off detection are all disabled as the device waits for 5V supply to start. After this, it transitions to the “standby” state and waits for the 12V start instruction (xACDC_STBY) from the system. Abnormal voltage detection, temperature detection, and AC off detection are enabled from the “standby” state onward.

When the 12V start instruction is received, the device enters the “12V start”, 12V abnormal voltage detection is disabled for a maximum of 550ms. After that, if the device enters the “normal operation” state 12V abnormal voltage detection is enabled.

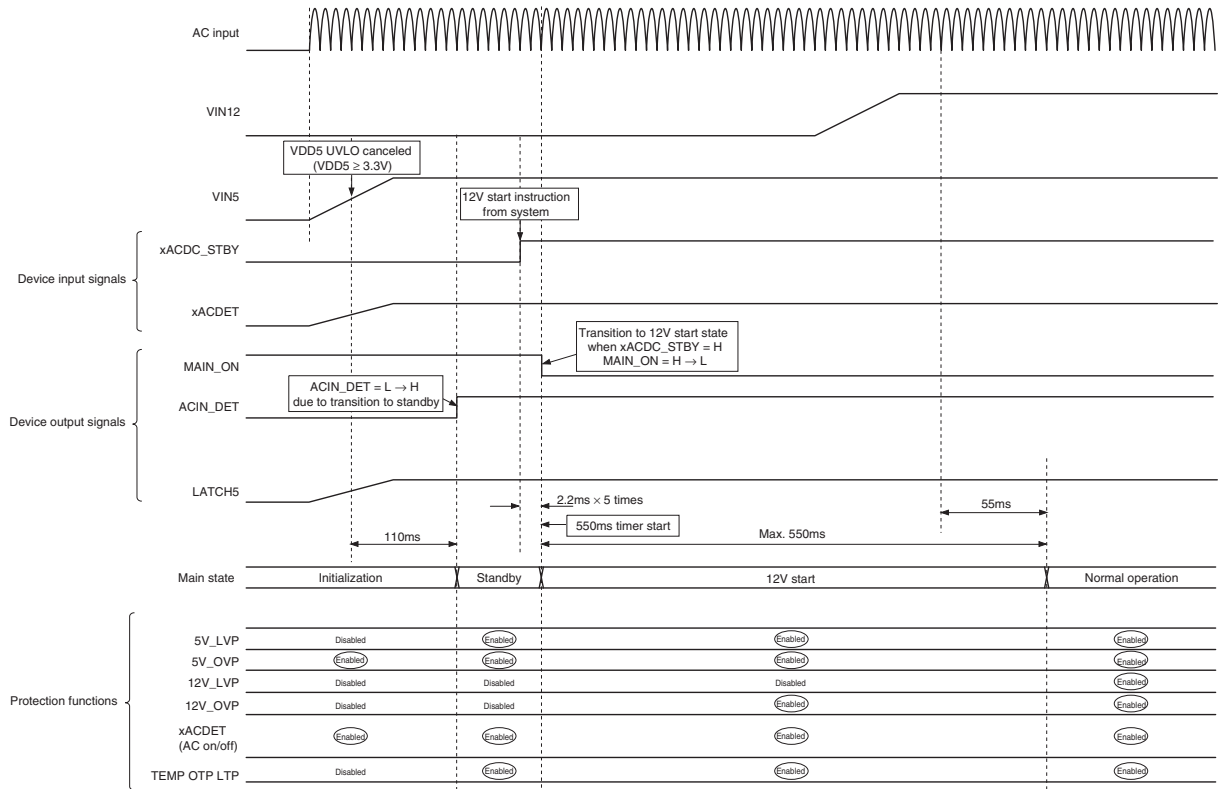

Fig.5. Start Timing Chart

Stop Timing Chart 1

Fig.6 shows a timing chart for the transition from “normal operation” to “latch stop”.

When a 12V stop instruction (xACDC_STBY = L) is received from the system during normal operation, the device transitions to the “standby” approximately 11ms later.

In the “standby” state 12V LVP and OVP detection are disabled.

When AC input stops while in “standby”, input from the primary side causes the xACDET pin to change from High to Low, and the device enters the “AC off” state 44ms later. When in the “AC off” state, 5V LVP detection is disabled.

With no AC input, the device enters the ANY state (reset condition) when 5V input drops and $VDD \leq 2.7V$.

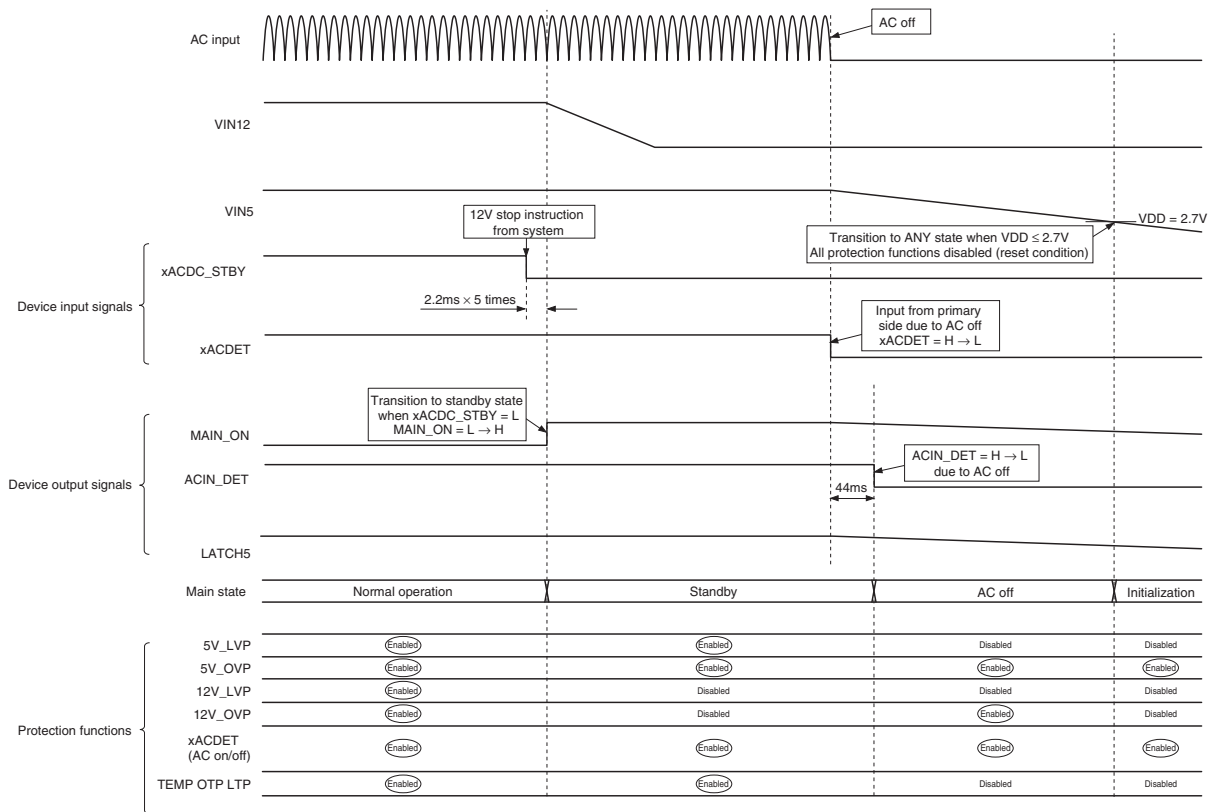

Fig.6. Stop Timing Chart 1

Stop Timing Chart 2

Fig.7 shows a timing chart for the transition from “AC off” to “stop” in the “normal operation” state. When AC input stops while in “normal operation”, input from the primary side causes the xACDET pin to change from High to Low, and the device enters the “AC off” state. When in the “AC off” state, 5V LVP detection is disabled.

With no AC input, the device enters the ANY state (reset condition) when 5V input drops and $VDD \leq 2.7V$.

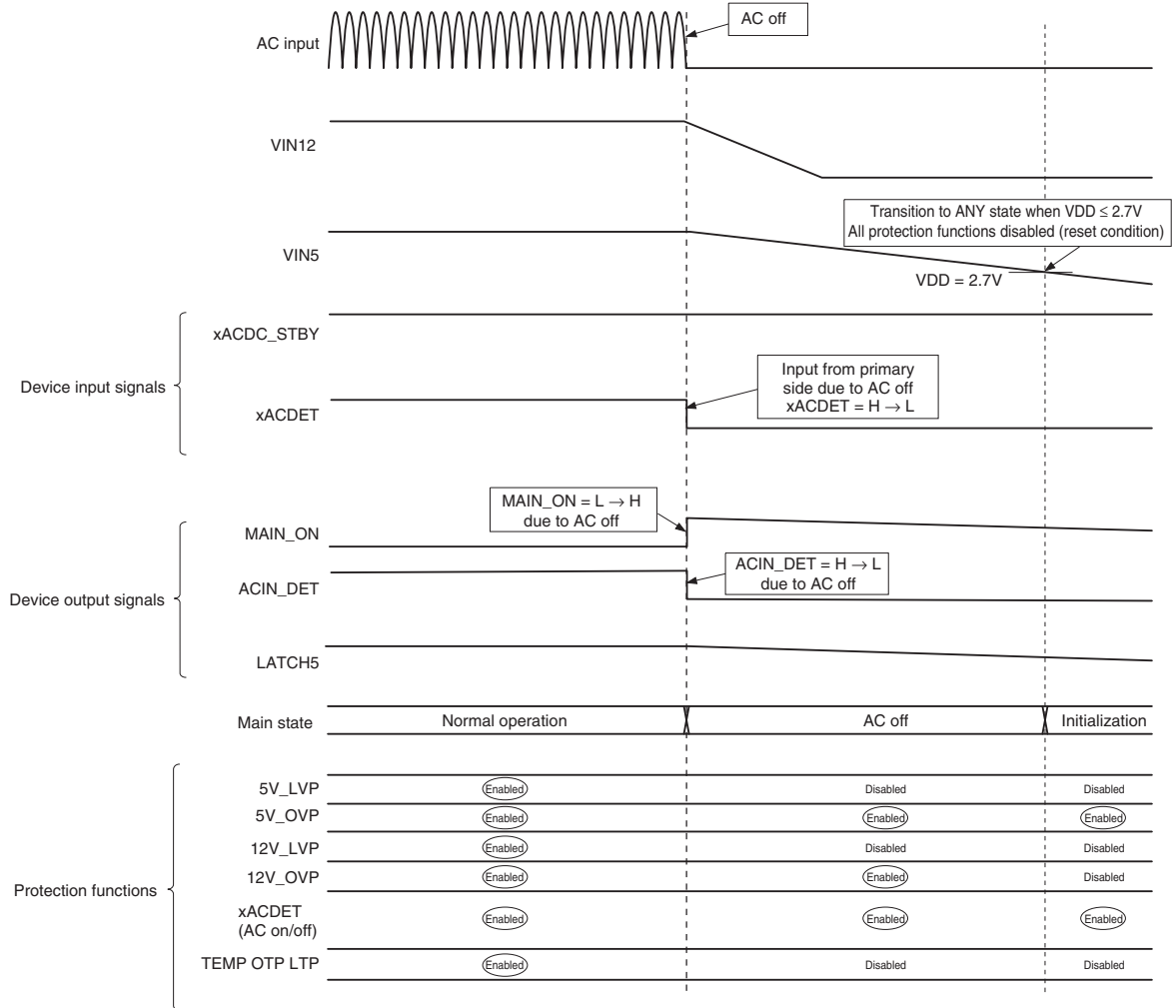

Fig.7. Stop Timing Chart 2

Emergency Stop Timing Chart 1

Fig.8 shows a timing chart for a temperature abnormality during “normal operation”. When a temperature abnormality occurs while in the “normal operation” state, the device transitions to the “error detection” state, then 55ms later to “12V latch stop” and 550ms later to “5V latch stop”.

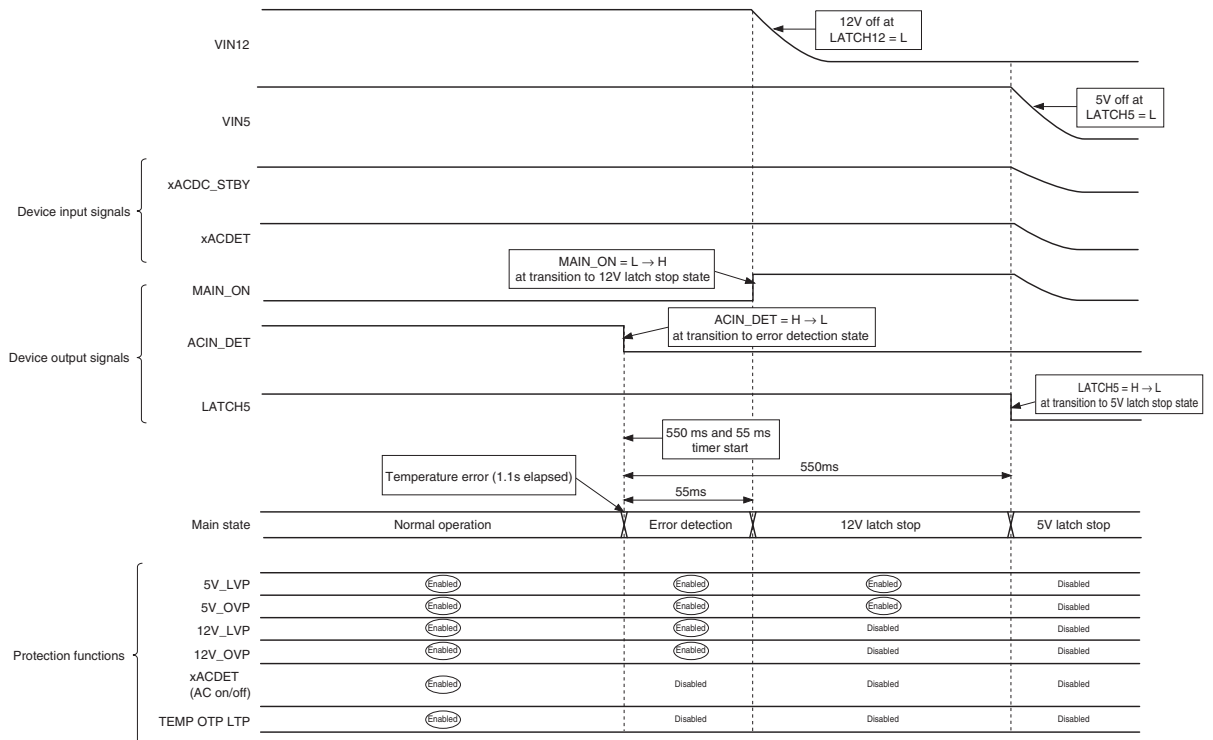

Fig.8. Temperature Abnormality during 12V Operation

Emergency Stop Timing Chart 2

Fig.9 shows a timing chart when detecting 12V voltage abnormality during “normal operation”. When 12V voltage abnormality occurs while in the “normal operation” state, the device transitions to the “12V latch stop” state, then 550ms later to “5V latch stop” state.

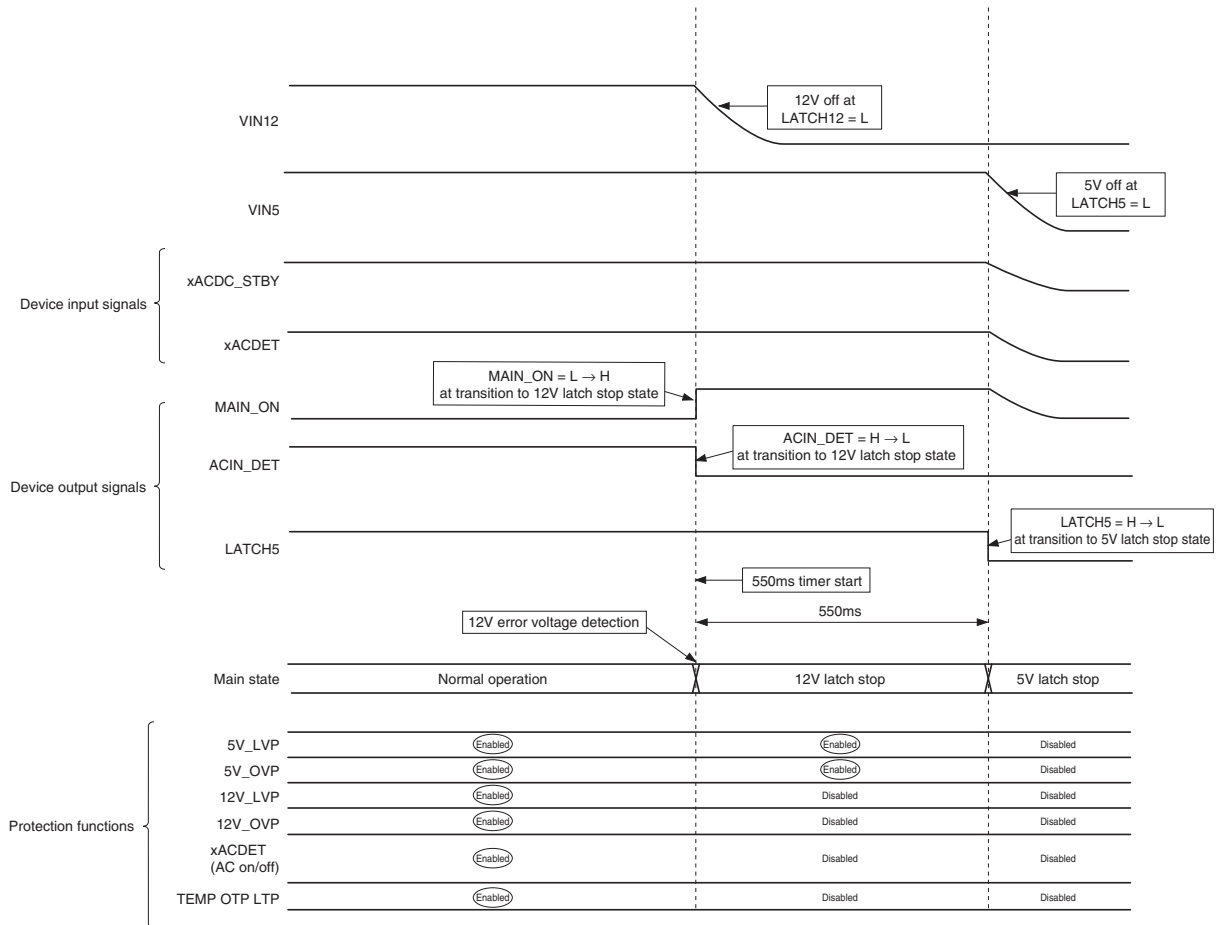

Fig.9. 12V Voltage Abnormality during 12V Operation

Emergency Stop Timing Chart 3

Fig.10 shows a timing chart when detecting 5V voltage abnormality during “normal operation”. When 5V voltage abnormality occurs while in the “normal operation” state, the device transitions to the “5V latch stop” state.

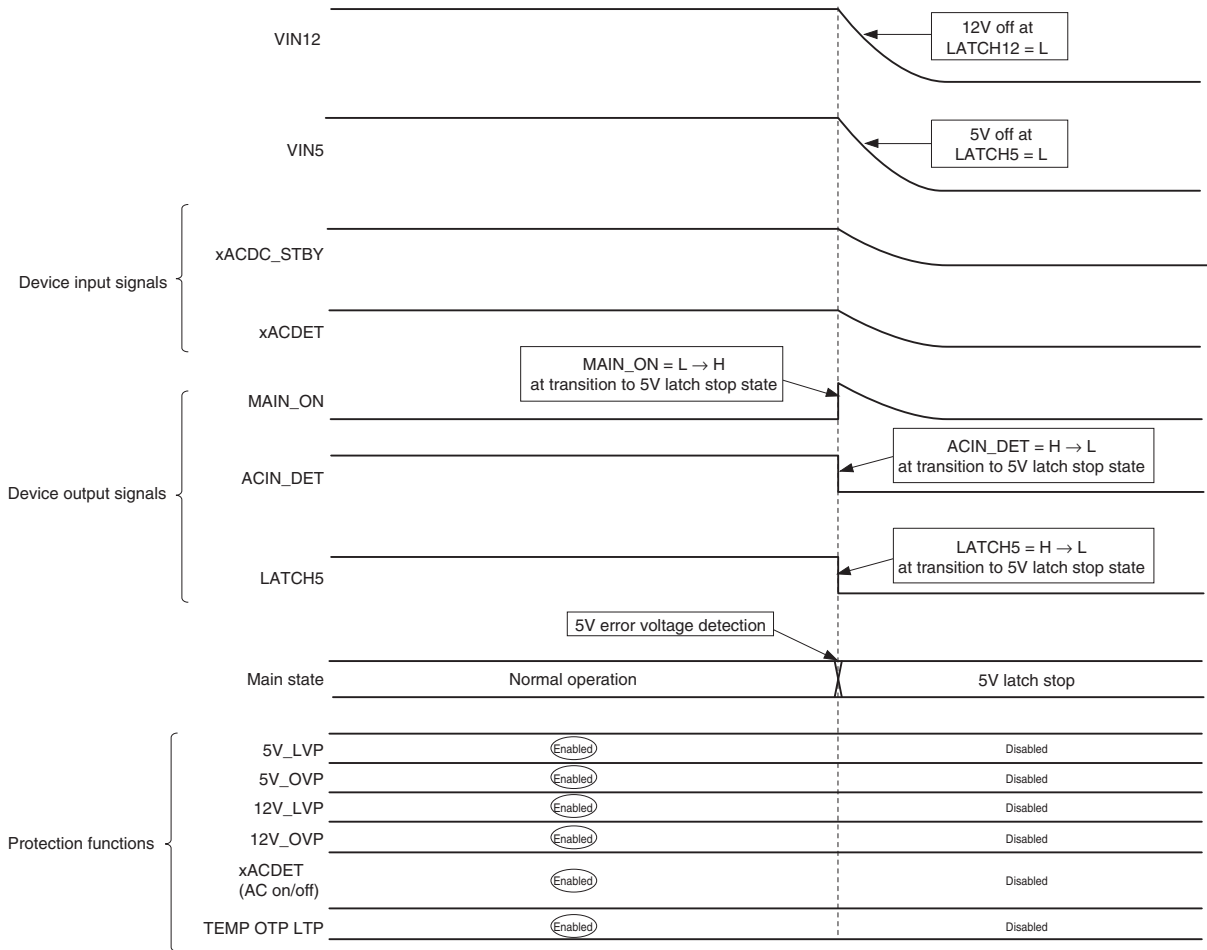

Fig.10. 5V Voltage Abnormality during 12V Operation

Emergency Stop Timing Chart 4

Fig.11 shows a timing chart when detecting 5V voltage abnormality or temperature abnormality during “standby”.

When 5V voltage abnormality or temperature abnormality occurs while in the “standby” state, the device transitions to the “5V latch stop” state.

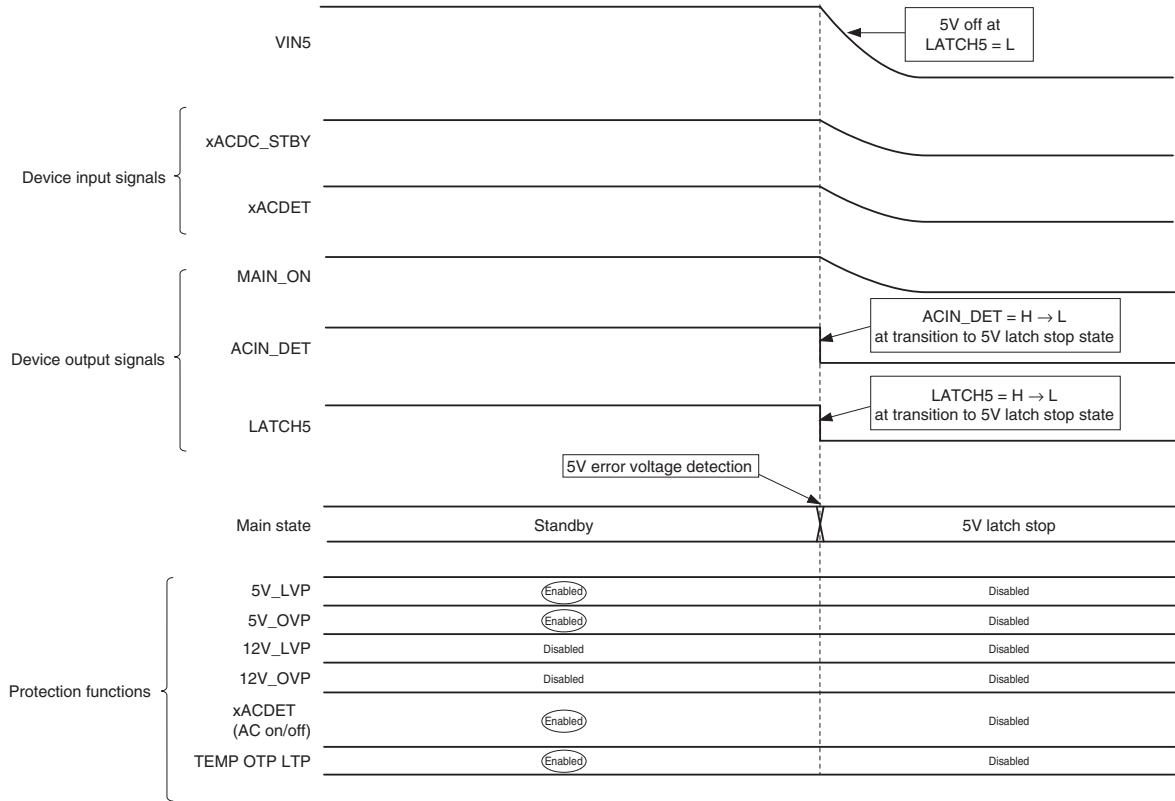

Fig.11. 5V Voltage Abnormality or Temperature Abnormality during Standby

AC Return Timing Chart 1

Fig.162 shows a timing chart for the period from AC off to return during “normal operation”. When primary side AC input stops while in the “normal operation” state, the xACDET pin, which is the secondary side input, goes Low and the device transitions to the “AC off” state. (See page 15 for details.) When AC input subsequently returns, the device transitions to the “AC return 1” state for 55ms, then to the “AC return 2” state for 550ms, and finally enters the “standby” state. If an AC off condition is detected while in an “AC return” state, the device again transitions to the “AC off” state.

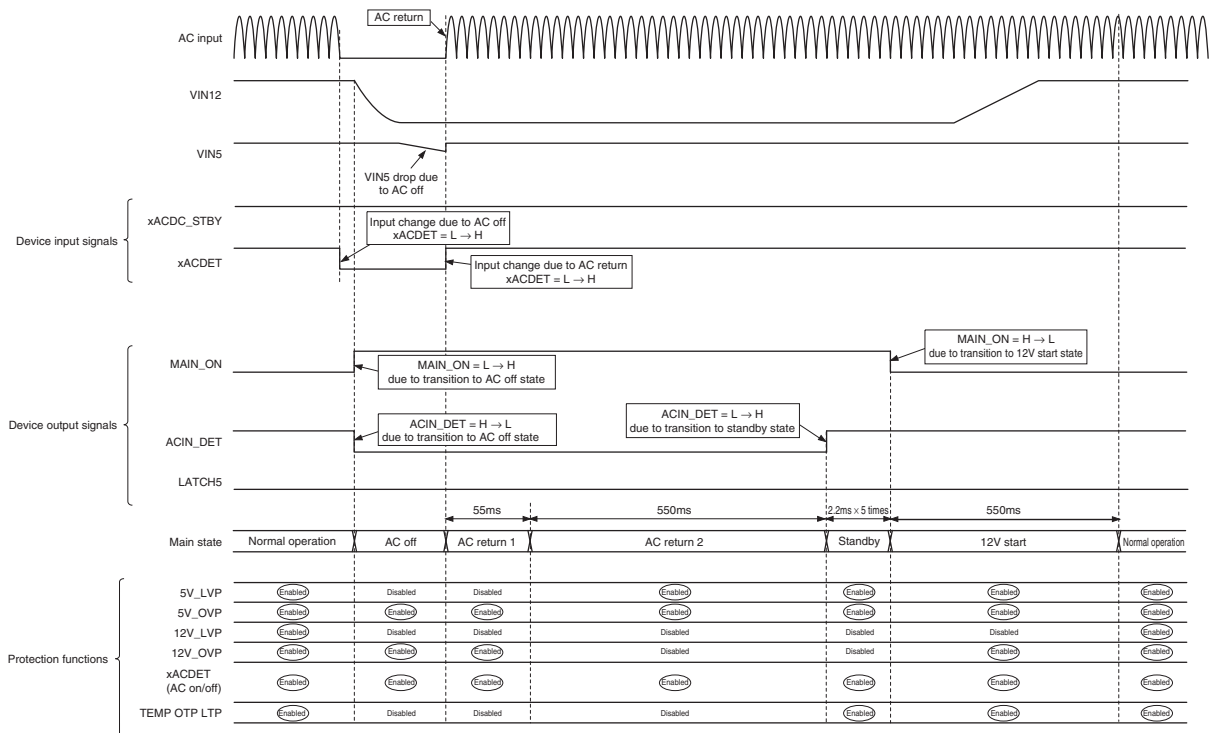

Fig.12. AC Off to Return during 12V Normal Operation

AC Return Timing Chart 2

Fig.13 shows a timing chart for the period from AC off to return during “standby”. When primary side AC input stops while in the “standby” state, the xACDET pin, which is the secondary side input, goes Low and the device transitions to the “AC off” state. (See page 15 for details.) When AC input subsequently returns, the device transitions to the “AC return 1” state for 55ms, then to the “AC return 2” state for 550ms, and finally enters the “standby” state. If an AC off condition is detected while in an “AC return” state, the device again transitions to the “AC off” state.

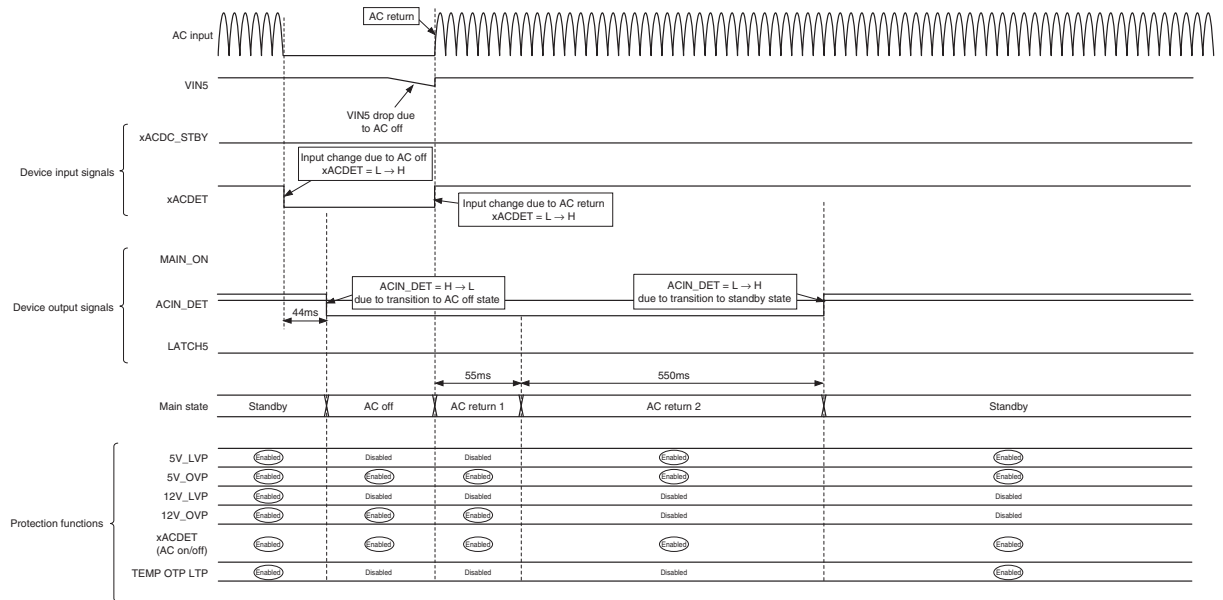
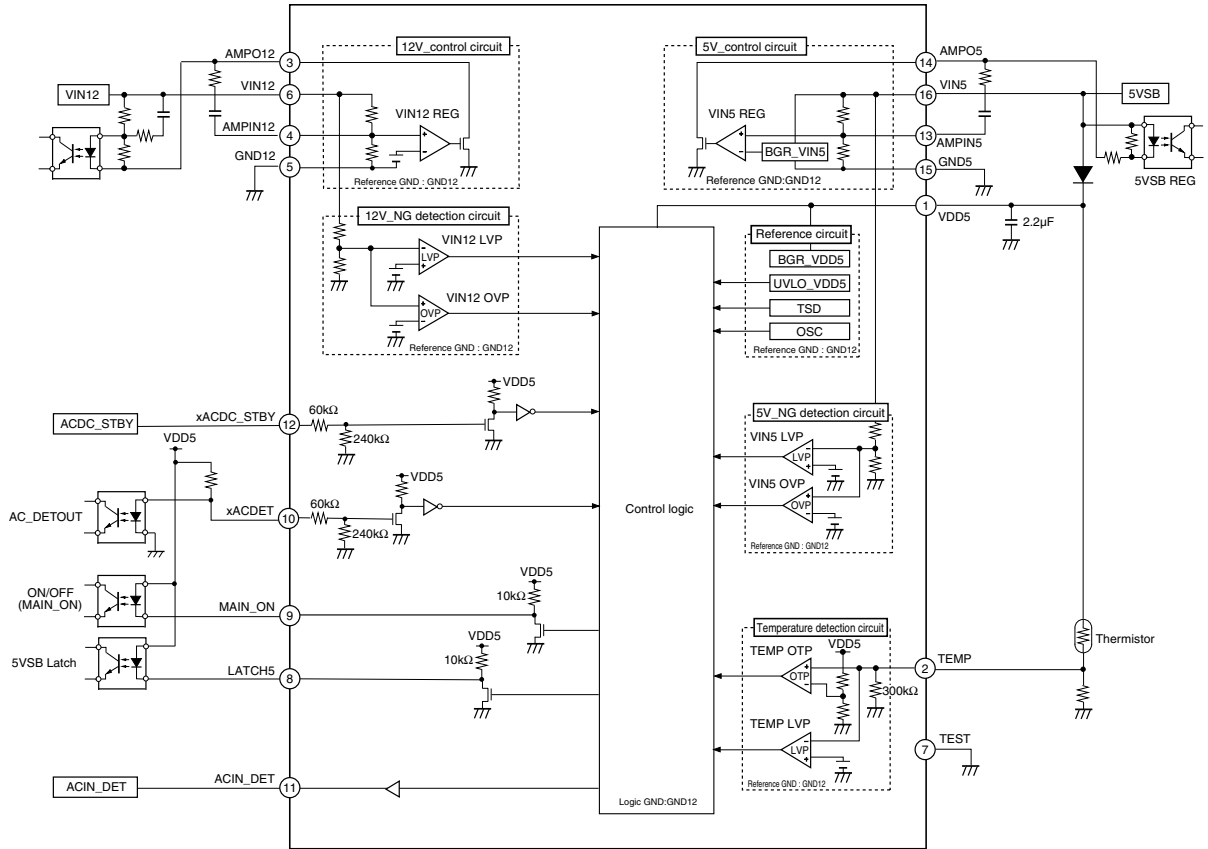

Fig.13. AC Off to Return during Standby

Application Circuit



Application circuits shown are typical examples illustrating the operation of the devices. Sony cannot assume responsibility for any problems arising out of the use of these circuits or for any infringement of third party patent and other right due to same.

Package Outline

(Unit: mm)

16PIN SOP (PLASTIC)

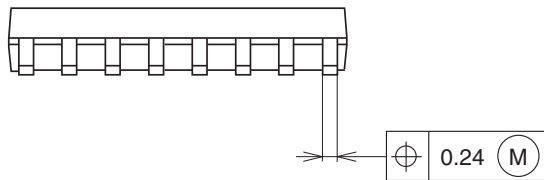
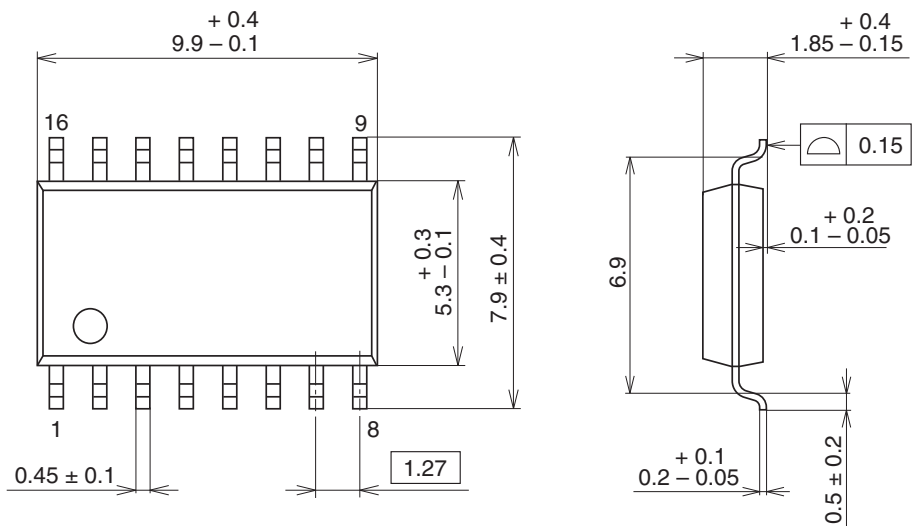

SONY CODE	SOP-16P-L01
EIAJ CODE	SOP016-P-0300
JEDEC CODE	—

PACKAGE STRUCTURE

PACKAGE MATERIAL	EPOXY RESIN
LEAD TREATMENT	SOLDER PLATING
LEAD MATERIAL	COPPER ALLOY
PACKAGE MASS	0.2g

LEAD PLATING SPECIFICATIONS

ITEM	SPEC.
LEAD MATERIAL	COPPER ALLOY
SOLDER COMPOSITION	Sn-Bi Bi:1-4wt%
PLATING THICKNESS	5-18 μ m