



- High Performance, 1-Axis and 3-Axis Accelerometers
- Small, Low-Cost
- Reliable Packaging with Screw-Down Mounting
- Factory Calibrated



GP Series

Applications

- Automotive Testing
- Instrumentation
- Equipment Monitoring

The GP Series accelerometers are low cost, general purpose, linear acceleration and/or vibration sensors available in ranges of $\pm 4g$, $\pm 10g$, and $\pm 25g$.

Common applications are automotive testing, instrumentation, and equipment monitoring. The GP Series sensing element is a silicon micro-machined capacitive beam. The capacitive beam is held in force balance for full scale non-linearity of less than 0.2%.

The GP Series sensors provide a direct high-level analog voltage output. The output requires no external signal conditioning electronics and may be directly interfaced to an A/D or other data acquisition hardware.

Compared to traditional piezoelectric and piezoresistive accelerometer technologies, the silicon micromachined sensors offer equivalent performance at a significantly lower cost.

The GP Series offers wide dynamic range, has excellent frequency response, operates on a single 4.9 to 5.5 VDC power supply, and is easy to interface to standard data acquisition systems. The 3-axis version (GP3) can be specified with an internal regulator (-R option) for use with a 5.5 to 36 V unregulated power supply.

The GP Series is offered with a standard 5-pin female connector. The highly flexible, low-mass cable prevents disruption of the measurement.

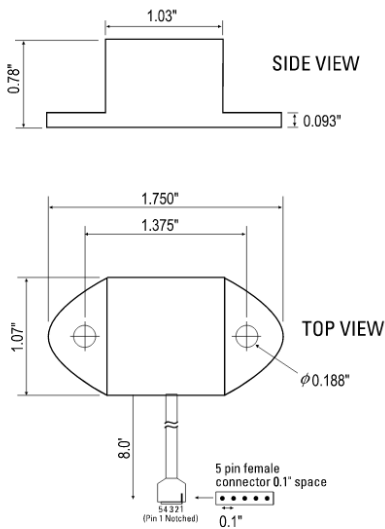

Standard Package Dimensions

Specifications	CXL04GP1 CXL04GP3	CXL10GP1 CXL10GP3	CXL25GP1 CXL25GP3	Remarks
Performance				
Input Range (g)	± 4	± 10	± 25	± 5%
Zero g Drift (g)	± 0.1	± 0.3	± 0.5	0°C to 70°C
Sensitivity (mV/g)	500 ± 15	200 ± 5	80 ± 2	
Transverse Sensitivity (% Span)	± 5	± 5	± 5	
Non-Linearity (% FS)	± 0.2	± 0.2	± 0.2	typical
Alignment Error (deg)	± 2	± 2	± 2	typical
Noise (mg rms)	10	25	25	typical
Bandwidth (Hz)	DC -100	DC -100	DC -100	
Environment				
Operating Temp. Range (°C)	-40 to +85	-40 to +85	-40 to +85	
Operating Temp. Range - AL (°C)	-40 to +105	-40 to +105	-40 to +105	
Shock (g)	2000	2000	2000	
Electrical				
Supply Voltage (Volts)	+ 4.9 to 5.5	+ 4.9 to 5.5	+ 4.9 to 5.5	
Supply Voltage -R option (Volts)	+ 5.5 to 36	+ 5.5 to 36	+ 5.5 to 36	
Supply Current (mA)	1/axis	3/axis	3/axis	typical
Zero g Output (Volts)	+ 2.375 ± 0.1	+ 2.375 ± 0.1	+ 2.375 ± 0.1	@25°C
Span Output (Volts)	± 2.0 ± 0.1	± 2.0 ± 0.1	± 2.0 ± 0.1	
Output Loading	> 2.0 < 2 nF	> 2.0 < 2 nF	> 2.0 < 2 nF	
Physical				
Standard package				
Size (in)	0.78 x 1.75 x 1.07	0.78 x 1.75 x 1.07	0.78 x 1.75 x 1.07	
(cm)	1.98 x 4.45 x 2.72	1.98 x 4.45 x 2.72	1.98 x 4.45 x 2.72	
Weight	1.62 oz (46 gm)	1.62 oz (46 gm)	1.62 oz (46 gm)	
Aluminum package (-AL option)				
Size (in)	0.95 x 2.00 x 1.20	0.95 x 2.00 x 1.20	0.95 x 2.00 x 1.20	
(cm)	2.41 x 5.08 x 3.05	2.41 x 5.08 x 3.05	2.41 x 5.08 x 3.05	
Weight	2.40 oz (68 gm)	2.40 oz (68 gm)	2.40 oz (68 gm)	

Notes: 1 -3dB, DC coupled sensor

Non-linearity is the deviation from a best fit straight line at full scale. Transverse sensitivity is error measured in the primary axis output created by forces induced in the orthogonal axis. Transverse sensitivity error is primarily due to the effects of misalignment. Zero g drift is specified as the typical change in 0 g level from its initial value at +25°C to its worst case value at Tmin or Tmax. Specifications subject to change without notice.

Pin	Color	Function
1	Red	Power In
2	Black	Ground
3	White	X-axis Out
4	Yellow	Y-axis Out
5	Green	Z-axis Out

Pin Diagram

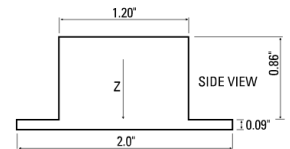
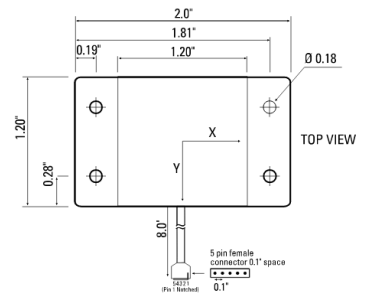

High Temperature Package Dimensions

Ordering Information

Model	Axes	Span (g)	Sensitivity (m V/g)	Noise (mg rms)	Bandwidth (Hz)
CXL04GP1	X	± 4	500	10	DC-100
CXL04GP3	TRI	± 4	500	10	DC-100
CXL10GP1	X	± 10	200	25	DC-100
CXL10GP3	TRI	± 10	200	25	DC-100
CXL25GP3	TRI	± 25	80	25	DC-100
OPTIONS					
-R	Voltage Regulator, 5.5 – 36 VDC input. (Available in GP3 models only.)				
-AL	High Temperature Package. Operating Temperature Range (°C): -40 to +105. (Available in GP3 models only.)				



High Temperature Package