

Bluetooth® Module

Description

The CXN1010 is a fully integrated Class 2 radio and baseband module conforming to ver. 1.1 of the Bluetooth® specification.

Features

- UART, USB, PCM codec, PIO, and AIO interfaces, enabling a wide range of applications.
- Small package: 10 × 14 × 1.5mm
- 8M-bit on-module flash memory
- Voltage regulator options: either on-module or external 1.8V regulator supported
- Based on the CXD3251GL, fully compatible with the Bluecore2-EXT from CSR
- Support for up to 7 slaves from a single master
- Channel quality driven data rate

General Specifications

- Product name: Bluetooth® module
- Antenna connector impedance: 50Ω
- External interfaces: UART, USB, PCM, PIO, AIO
- Supply voltage: 2.3 to 3.6V*
- Package dimensions: 10.0 × 14.0 × 1.5mm

* An external 1.75^{+0.15}_{-0.05} V power supply is required for modules without internal voltage regulator (customer option).

Bluetooth® is a trademark owned by Bluetooth SIG, Inc. and licensed to Sony.

Sony reserves the right to change products and specifications without prior notice. This information does not convey any license by any implication or otherwise under any patents or other right. Application circuits shown, if any, are typical examples illustrating the operation of the devices. Sony cannot assume responsibility for any problems arising out of the use of these circuits.

Block Diagram

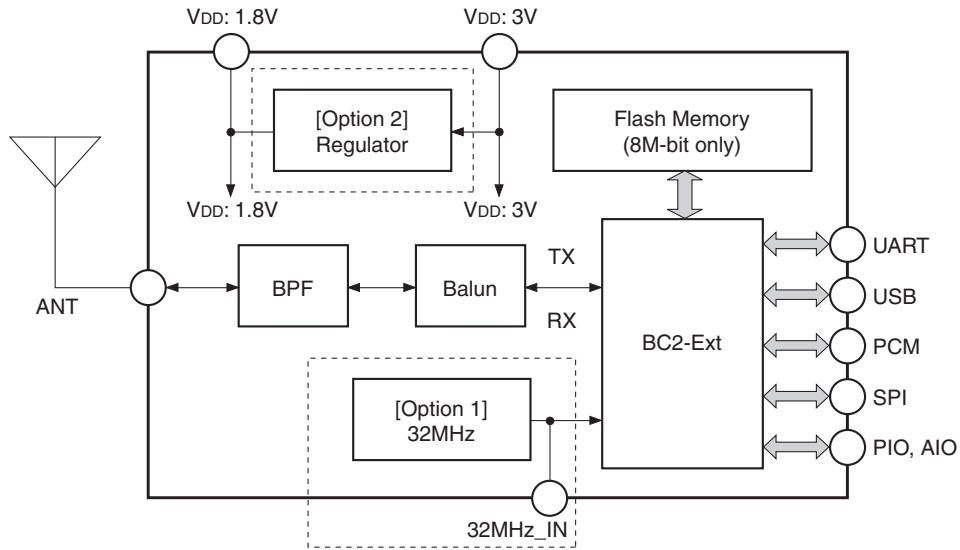

Module type	[Option 1] X'tal	[Option 2] Regulator	Supply V _{DD}
CXN1010-3AAL	Mount	Mount	3V only
CXN1010-2BAL	Mount	No mount	1.8V only
CXN1010-3BAL	Mount	No mount	1.8V & 3V
CXN1010-3CAL	No mount	Mount	3V only
CXN1010-2DAL	No mount	No mount	1.8V only
CXN1010-3DAL	No mount	No mount	1.8V & 3V

Pin Configuration (Top View)

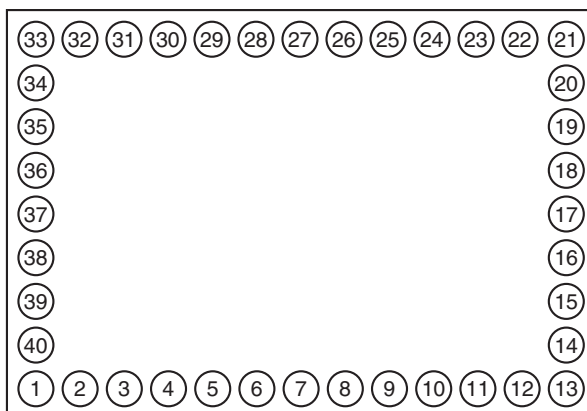

Pin Description

No.	Name	Type	Description
1	GND	GND	Ground.
2	RF	Analog	RF input/output.
3	GND	GND	Ground.
4	PIO_4/ USB_ON	Bi-directional with programmable weak internal pull-up/down	Programmable I/O line or USB on.
5	PIO_3/ USB_WAKE_UP	Bi-directional with programmable weak internal pull-up/down	Programmable I/O line or output goes high to wake up PC when in USB mode.
6	PIO_6	Bi-directional with programmable weak internal pull-up/down	Programmable I/O line.
7	PIO_8	Bi-directional with programmable weak internal pull-up/down	Programmable I/O line.
8	32MHz_IN	External clock input. (Internal clock type is NC.)	External clock input. A coupled capacitor is needed.
9	PIO_7	Bi-directional with programmable weak internal pull-up/down	Programmable I/O line.
10	SPI_MISO	CMOS output, tristatable with weak internal pull-down	Serial Peripheral Interface data output.
11	PIO_9	Bi-directional with programmable weak internal pull-up/down	Programmable I/O line.
12	CE	CMOS input	1.8V regulator control. Regulator on at high.
13	GND	GND	Ground.
14	SPI_CLK	CMOS input with weak internal pull-down	Serial Peripheral Interface clock.
15	V _{DD} 3.0	V _{DD}	Supply voltage 3.0V. This pin need a decoupling capacitor that more than 2.2μF.

No.	Name	Type	Description
16	PIO_10	Bi-directional with programmable weak internal pull-up/down	Programmable I/O line.
17	AIO_0	Bi-directional	Programmable I/O line.
18	USB-	Bi-directional	USB data minus.
19	AIO_1	Bi-directional	Programmable I/O line.
20	USB+	Bi-directional	USB data plus.
21	GND	GND	Ground.
22	AIO_2	Bi-directional	Programmable I/O line.
23	PIO_2	Bi-directional with programmable weak internal pull-up/down	Programmable I/O line.
24	PIO_1	Bi-directional with programmable weak internal pull-up/down	Programmable I/O line.
25	PD-RST	CMOS input with 1k Ω pull-down	Reset at high. Input is debounced, so this pin should be high for 5ms or more to cause a reset.
26	PIO_0	Bi-directional with programmable weak internal pull-up/down	Programmable I/O line.
27	PIO_11	Bi-directional with programmable weak internal pull-up/down	Programmable I/O line.
28	UART_RTS	CMOS output, tristatable with weak internal pull-up	Weak internal pull-up UART request to send, active low.
29	UART_TX	CMOS output	UART data output, active high.
30	UART_RX	CMOS input with weak internal pull-down	UART data input, active high.
31	PCM_IN	CMOS input with weak internal pull-down	PCM data input.
32	PCM_SYNC	Bi-directional with 100k Ω pull-down	PCM data sync.
33	GND	GND	Ground.
34	PCM_OUT	CMOS output, tristatable with weak internal pull-down	PCM data output.
35	PCM_CLK	Bi-directional with weak internal pull-down	PCM data clock.
36	UART_CTS	CMOS input with weak internal pull-down	UART clear to send, active low.
37	SPI_MOSI	Bi-directional with programmable weak internal pull-up/down	Serial Peripheral Interface data input.
38	PIO_5/ USB_DETACH	CMOS input with weak internal pull-up	Programmable I/O line or chip detaches from USB when this input is high.
39	SPI_CSB	CMOS input with weak internal pull-down	Chip select for Serial Peripheral Interface, active low.
40	V _{DD} 1.8	V _{DD}	Supply voltage 1.8V. This pin need a decoupling capacitor that more than 2.2 μ F.

Electrical Characteristics

Absolute Maximum Ratings

Item		Min.	Max.	Unit
Storage temperature		-20	+85	°C
Supply voltage	V _{DD1.8}	-0.40	1.90	V
	V _{DD3.0}	-0.40	3.60	V

Recommended Operating Conditions

Item		Min.	Max.	Unit
Operating temperature range		-20	+85	°C
Supply voltage	V _{DD1.8}	1.70	1.90	V
	V _{DD3.0}	2.30	3.60	V

Input/Output Terminal Characteristics

(Temperature: -20 to +85°C)

This I/O pin characteristics is the Bluetooth® IC specifications used internally of the CXN1010.

Digital Terminals		Min.	Typ.	Max.	Unit
Input Voltage					
V _{IL} input logic level low	V _{DD3.0} = 3.0V	-0.4		0.8	V
	V _{DD1.8} = 1.8V	-0.4		0.4	V
V _{IH} input logic level high		0.7 × V _{DD3.0}		V _{DD3.0} + 0.4	V
Output Voltage					
V _{OL} output logic level low (I _O = 4.0mA)	V _{DD3.0} = 3.0V	—	—	0.2	V
	V _{DD1.8} = 1.8V	—	—	0.4	V
V _{OH} output logic level high (I _O = 4.0mA)	V _{DD3.0} = 3.0V	V _{DD3.0} - 0.2	—	—	V
	V _{DD1.8} = 1.8V	V _{DD1.8} - 0.4	—	—	V
Input and Tristate Current with:					
Weak pull-up		-5	-1	0	μA
Weak pull-down		0	1	5	μA
I/O pad leakage current		-1	0	1	μA
C _i input capacitance		2.5	—	10	pF

Input/Output Terminal Characteristics (continued)

USB Terminals	Min.	Typ.	Max.	Unit
Input Threshold				
V _{IL} input logic level low	—	—	0.3 × V _{DD3.0}	V
V _{IH} input logic level high	0.7 × V _{DD3.0}	—	—	V
Input Leakage Current				
GND < V _{IN} < V _{DD3.0}	−1	—	1	μA
C _i input capacitance	2.5	—	10	pF
Output Levels to Correctly Terminated USB Cable				
V _{OL} input logic level low	0	—	0.2	V
V _{OH} input logic level high	2.8	—	V _{DD3.0}	V

Auxiliary DAC, 8-bit Resolution	Min.	Typ.	Max.	Unit
Resolution	—	—	8	Bits
Average output step size	12.5	14.5	17	mV
Output Voltage	Monotonic: 0.2 to V _{DD3.0} − 0.2V			
Voltage range (I _o = 0)	GND	—	V _{DD3.0}	V
Current range	−10	—	0.1	mA
Minimum output voltage (I _o = 100μA)	0	—	0.2	V
Maximum output voltage (I _o = 10mA)	V _{DD3.0} − 0.3	—	V _{DD3.0}	V
High impedance leakage current	−1	—	1	μA
Offset	−220	—	120	mV
Integral non-linearity	−2	—	2	LSB
Starting time (50pF load)	—	—	10	μs
Setting time (50pF load)	—	—	5	μs

PD-RST Terminal	Min.	Typ.	Max.	Unit
V _{DD} falling threshold	1.40	1.50	1.60	V
V _{DD} rising threshold	1.50	1.60	1.70	V
Hysteresis	0.05	0.10	0.15	V

Input/Output Terminal Characteristics (continued)

CE Terminal	Min.	Typ.	Max.	Unit
Input Voltage				
V _{IL} input logic level low	—	—	0.2	V
V _{IH} input logic level high	1.7	—	V _{DD3.0}	V
Input Current				
I _{IL} input logic level low	-0.15	—	0.15	μA
I _{IH} input logic level high	-0.15	—	0.15	μA

Radio Characteristics

(Temperature: -20 to +85°C)

Transmitter		Condition	Min.	Typ.	Max.	Unit	Remark
Output power (Average)		N & ETC	-6	0	4	dBm	Internal PA = 46
Modulation characteristics	delta-f1 avg	N & ETC	140	165	175	kHz	11110000 mod.
	delta-f2 max	N & ETC	115	140		kHz	1010 mod.
Initial carrier frequency tolerance		N & ETC		10	75	kHz	
Carrier frequency drift	DH1	N & ETC		12	25	kHz	
	DH3	N & ETC		12	40	kHz	
	DH5	N & ETC		15	40	kHz	
Drift rate	DH1	N & ETC		8	20	kHz/ 50μs	
	DH3	N & ETC		10	20	kHz/ 50μs	
	DH5	N & ETC		12	20	kHz/ 50μs	
20dB bandwidth		N & ETC		900	1000	kHz	
Adjacent channel power	M-N = 2	N & ETC		-40	-20	dBm	
	M-N ≥3	N & ETC		-50	-40	dBm	
Out-of-band spurious emissions	30M-1G	N & ETC		-65	-36	dBm	
	1G-12.75G	N & ETC		-55	-30	dBm	
	1.8G-1.9G	N & ETC		-75	-47	dBm	
	5.15G-5.3G	N & ETC		-75	-47	dBm	

NTC: Normal Test Conditions +15 to +35°C, N & ETC: Normal & Extreme Test Conditions -20 to +85°C

Radio Characteristics (Continued)

Receiver		Condition	Min.	Typ.	Max.	Unit	Remark
Sensitivity (single slot packets)		N & ETC		-85	-78	dBm	BER < 0.1%
C/I performance	co-ch.	NTC		9	11	dB	
	1MHz	NTC		-2	0	dB	
	2MHz	NTC		-34	-30	dB	
	≥3MHz	NTC		-43	-40	dB	
	Image	NTC		-18	-9	dB	
	Image ± 1MHz	NTC		-23	-20	dB	
Blocking performance	30-2000M	NTC	-10			dBm	
	800M-1000M	NTC		10		dBm	
	1800M-1900M	NTC		10		dBm	
	2000-2399M	NTC	-27			dBm	
	2498-3000M	NTC	-27			dBm	
	3G-12.75G	NTC	-10			dBm	
Inter modulation performance		NTC	-39	-30		dBm	
Spurious emissions	30M-1G	N & ETC		-78	-57	dBm	
	1G-12.75G	N & ETC		-55	-47	dBm	
Maximum input level		NTC	-20	2	5	dBm	

NTC: Normal Test Conditions, N & ETC: Normal & Extreme Test Conditions

Current Consumption

(Temperature: -20 to +85°C)

Mode		Average	Peak	Unit	Remark
SCO connection HV3 (1s interval sniff mode)		26		mA	Master or Slave
SCO connection HV1 (Master or Slave)		53		mA	
ACL data transfer 115.2Kbps UART (Master)		15.5		mA	
ACL data transfer 720Kbps USB		53		mA	Master or Slave
ACL connection, Sniff Mode 40ms interval		4		mA	38.4Kbps BCSP
ACL connection, Sniff Mode 1.28s interval		0.5		mA	38.4Kbps BCSP
Parked Slave, 1.28s beacon interval		0.6		mA	38.4Kbps BCSP
Deep sleep mode		0.06	20	mA	38.4Kbps BCSP
Sleep mode		2.2	22	mA	115.2Kbps H4
Peak RF current during RF burst	(0dBm Tx)	57	68	mA	
	(Rx)	47	70	mA	

Marking Contents

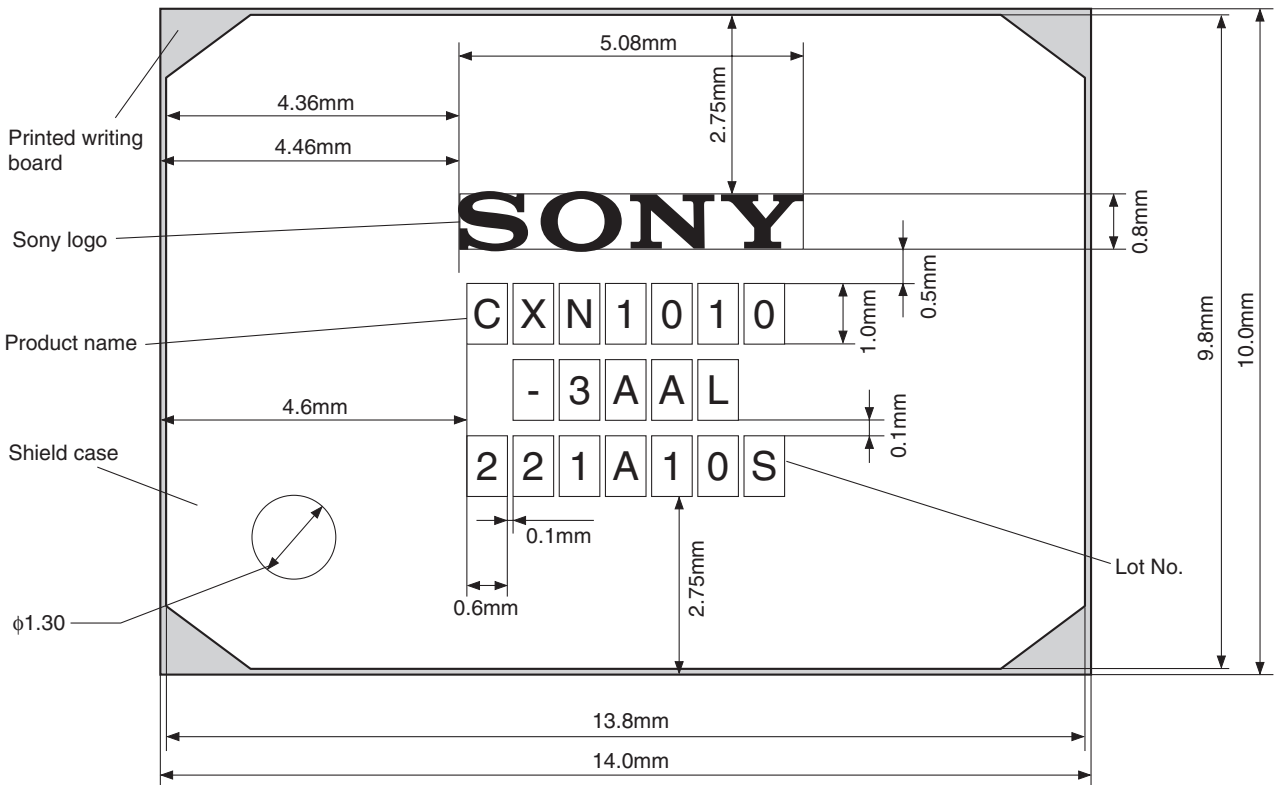

- Sony logo: Fixed
- Product name: The string of alphanumerics "-3AAL" on the second line differs according to the module contents.
- Lot No.: It is displayed according to "The change-control marking rule of IC Lot No." (QR-3007-001). (ex. "221A10S" on the third line means "20th, May, 2002. Lot No.10 produced in Senmaya").

Recommended Temperature Profile for Unleaded Reflow Soldering

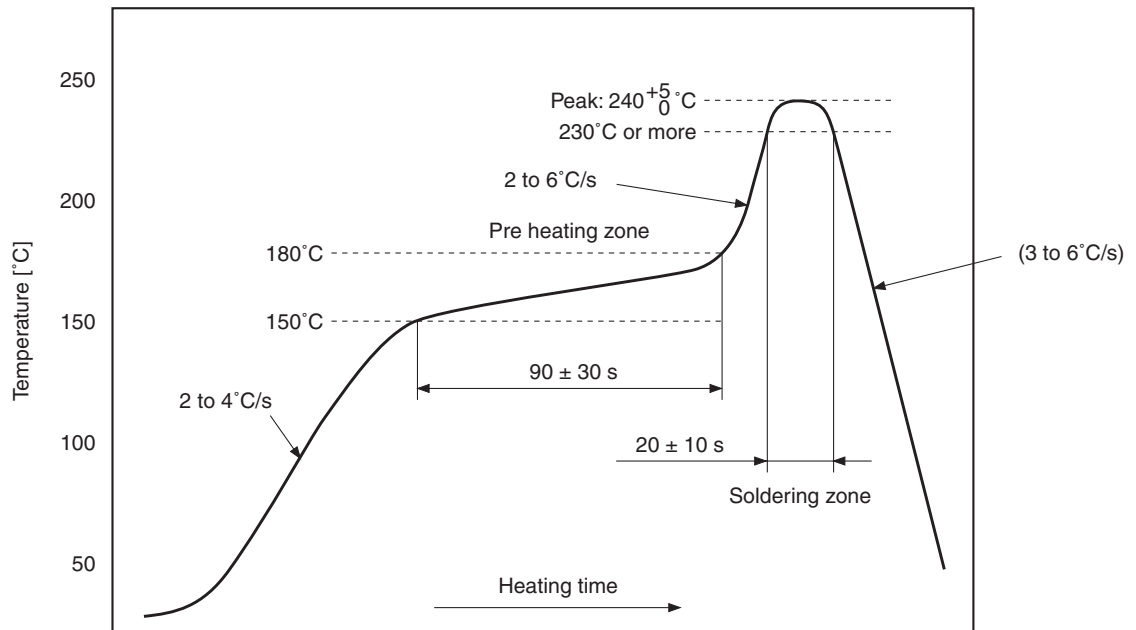

Radio Characteristics Measurement System Block Diagram (Application System Block Diagram)

System A

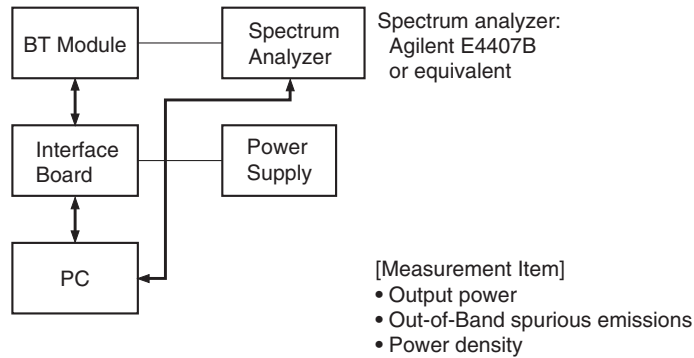

System B

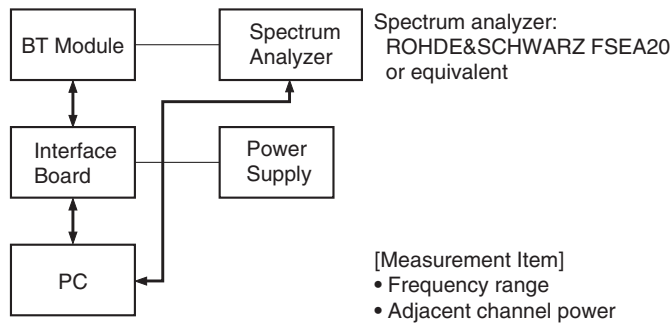

System C

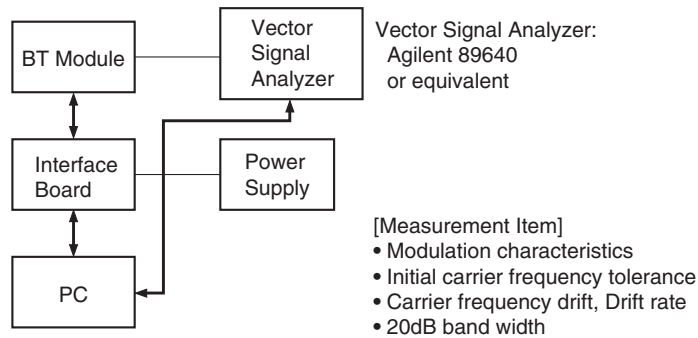

System D

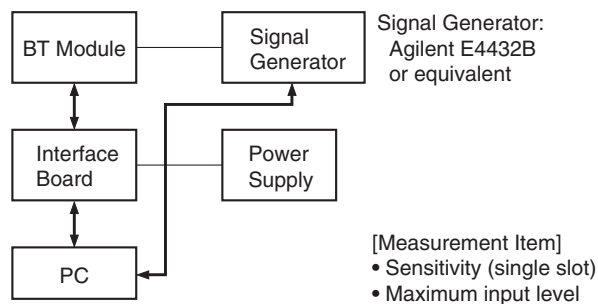

System E

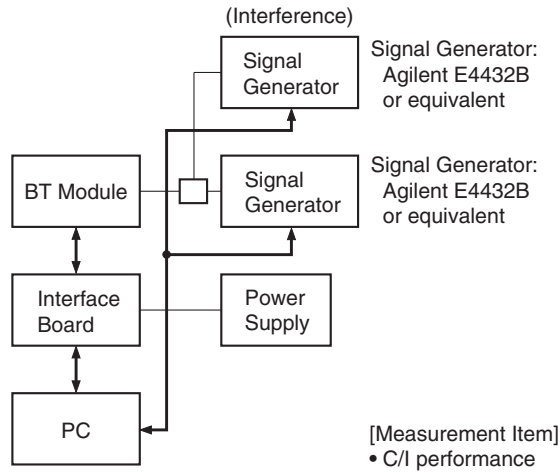

System F

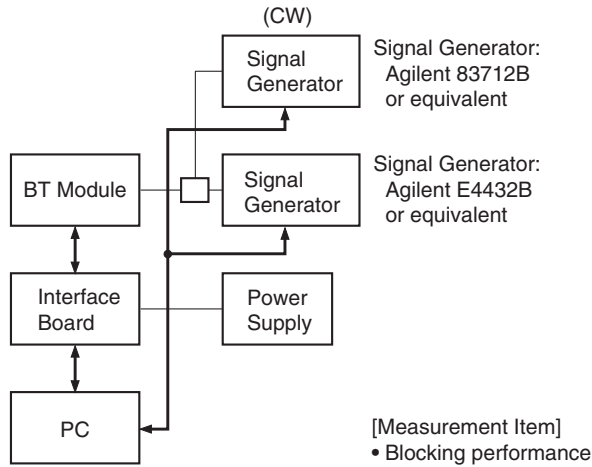

System G

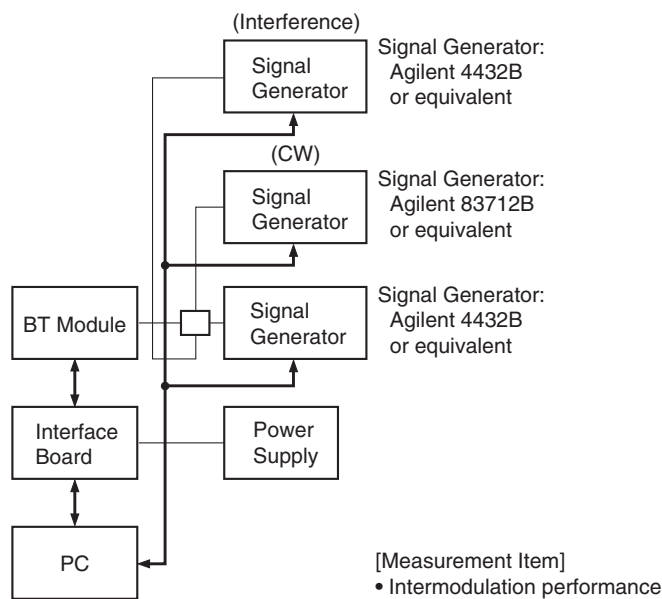

* For details of the contents below, see the specifications of the BlueCore 2-External (equivalent to the CXD3251GL) made by CSR.

Software Stack

The CXN1010 features a 16-bit RISC microcontroller which runs a software stack complying with Bluetooth specifications ver. 1.1.

The following are the three software stack options to integrate into the CXN1010.

1) HCI Stack

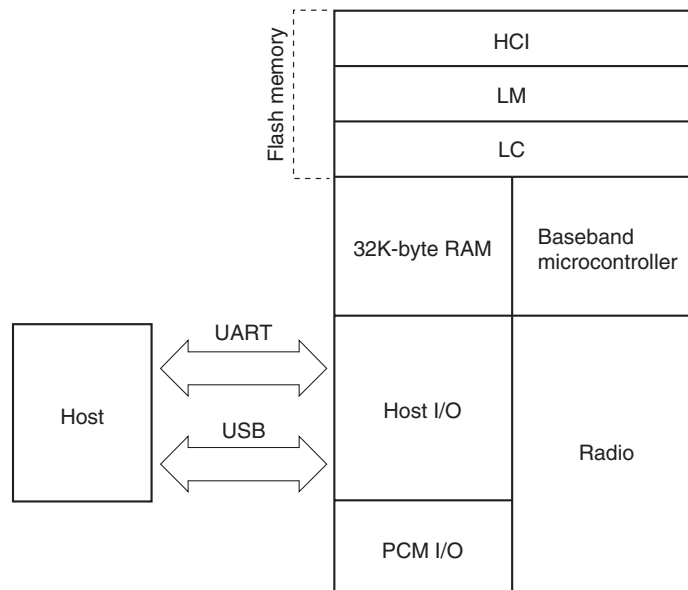

HCI Stack Configuration

The HCI stack enables the layers up to the host controller interface (HCI) to be executed by the on-module RISC microcontroller. It is considered to be the most common stack configuration with general-purpose capabilities. All layers above HCI are handled by the host processor.

2) RFCOMM Stack

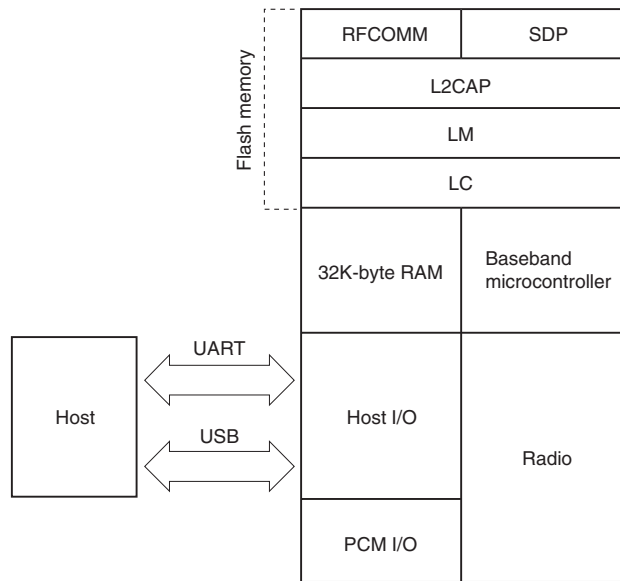

RFCOMM Stack Configuration

The RFCOMM stack enables the layers up to RFCOMM to be executed by the on-module RISC microcontroller. Then, the amount of processing is reduced on the host processor.

3) Virtual Machine Stack

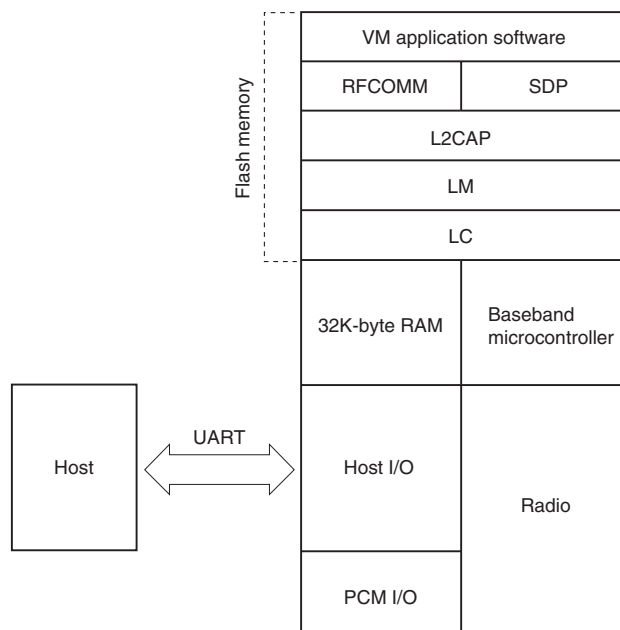

Virtual Machine Stack Configuration

The Virtual Machine stack eliminates the need for a host processor. The applications and Bluetooth stack can be run on the integrated RISC microprocessor using an application execution environment called Virtual Machine (VM).

In order to develop applications, the BlueLab[®] software development environment (SDK) and Casira development kit supplied by CSR are required. Inquire for further details.

• External Interfaces

UART Interface

The UART interface makes it easy to communicate with other serial devices using the RS-232 standard*1.

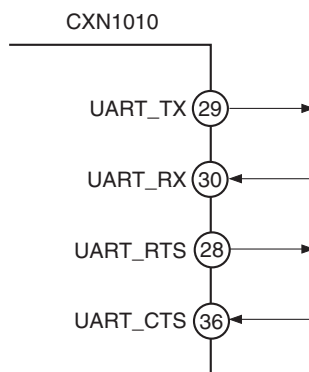

UART Pins

As shown in the figure above, four signals are used to execute the UART function. When the CXN1010 is connected to another digital device, data is transmitted between the two devices using the UART_RX and UART_TX signals. The remaining two low active signals, UART_CTS and UART_RTS, can be used for RS-232 hardware flow control. All the UART pins are configured as CMOS I/O pins. Their signal levels are 0V and V_{DD}3.0. The baud rate, packet format and other UART configuration parameters are set using PS Tool or other BlueCore software.

Note: In order to communicate with UART at the maximum data rate using a standard PC, a serial port adapter card with acceleration must be installed in the PC.

*1 The RS-232 protocol is used, but the voltage level is from 0V to V_{DD}3.0. (An RS-232 transceiver IC must be externally attached.)

Parameter		Possible values
Baud rate	Minimum	1200 baud (≤2% error) 9600 baud (≤1% error)
	Maximum	1.5M baud (≤1% error)
Flow control		RTS/CTS or none
Parity		None, odd or even
Number of stop bits		1 or 2
Bits per channel		8

UART Settings

With the UART interface, the CXN1010 can be reset as soon as a break signal is received. As shown in the figure below, the break is identified by the continuous low logic level in the UART_RX pin. Resetting occurs if t_{BRK} is longer than the value defined by PSKEY_HOST_IO_UART_RESET_TIMEOUT (0x1A4) persistent store key. The system can be initialized to a known status from the host using this function. The CXN1010 can also send break characters that can be used for starting the host.

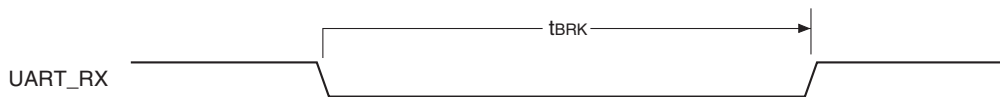

Break Signal

The frequently used baud rates and the values of the PSKEY_UART_BAUD_RATE (0x204) persistent store key linked to those rates are shown in the table below. These standard values are not necessarily required conditions, and all baud rates within the range supported can be set by the persistent store key with the following equation.

$$\text{Baud Rate} = \frac{\text{PSKEY_UART_BAUD_RATE}}{0.004096}$$

Baud rate	Persistent store value		Error
	Hex	Dec	
1200	0x0005	5	1.73%
2400	0x000A	10	1.73%
4800	0x0014	20	1.73%
9600	0x0027	39	-0.82%
19200	0x004F	79	0.45%
38400	0x009D	157	-0.18%
57600	0x00EC	236	0.03%
76800	0x013B	315	0.14%
115200	0x01D8	472	0.03%
230400	0x03B0	944	0.03%
460800	0x075F	1887	-0.02%
921600	0x0EBF	3775	0.00%
1382400	0x161E	5662	-0.01%

Standard Baud Rates

USB Interface

The USB pins of the CXN1010 support a full speed (12Mbps) USB interface. They enable direct drive of the USB cable, thereby obviating the need for an external USB transceiver. With this interface, the CXN1010 can operate as a USB unit and respond to requests from a PC or other master host controller. The interface supports both OHCI and UHCI standards. It also complies with Bluetooth specifications Ver.1.1 and part H2. Although USB is a system that is capable of both master and slave operations, the CXN1010 supports USB slave operations only.

Serial Peripheral Interface (SPI)

When data is sent or received through the SPI pins, the CXN1010 uses 16-bit data and 16-bit addresses. Through these pins, data is transmitted and received while the internal processor is operating and not operating. Data is written or read one word at a time unless the auto increment function is used to access blocks.

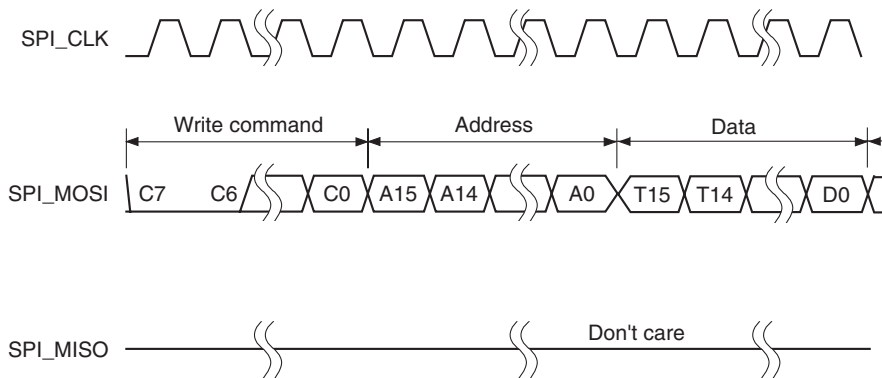

Write Operation A

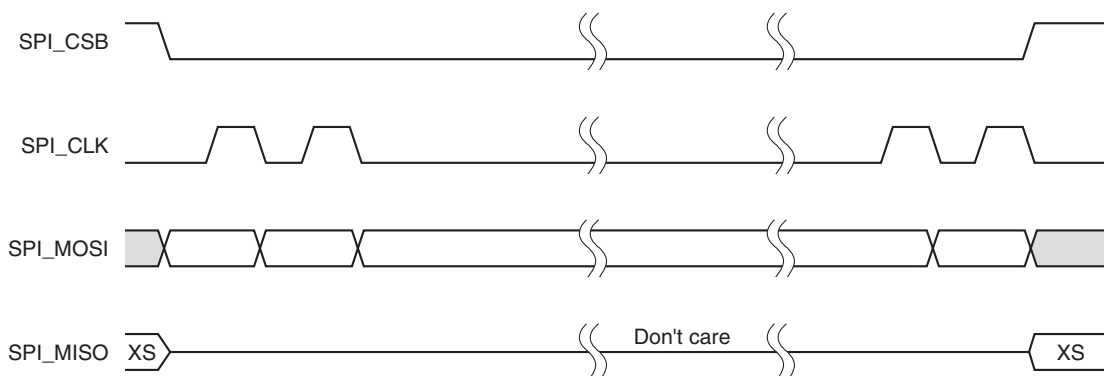

Write Operation B

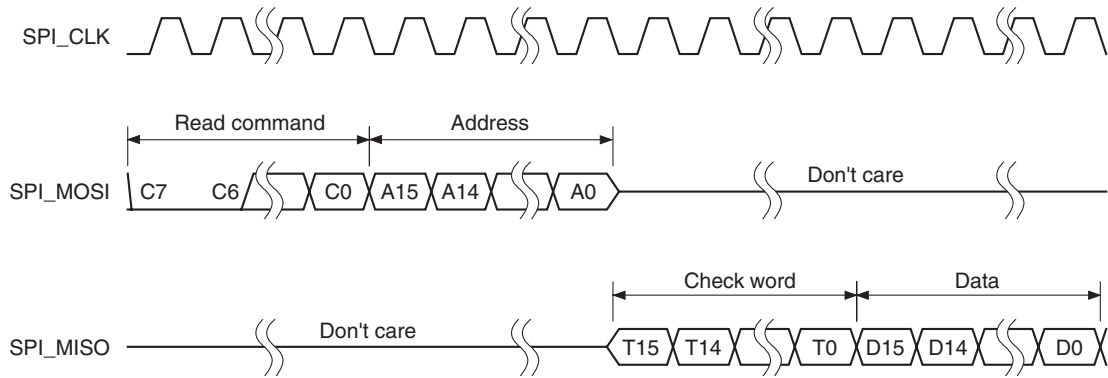

Read Operation A

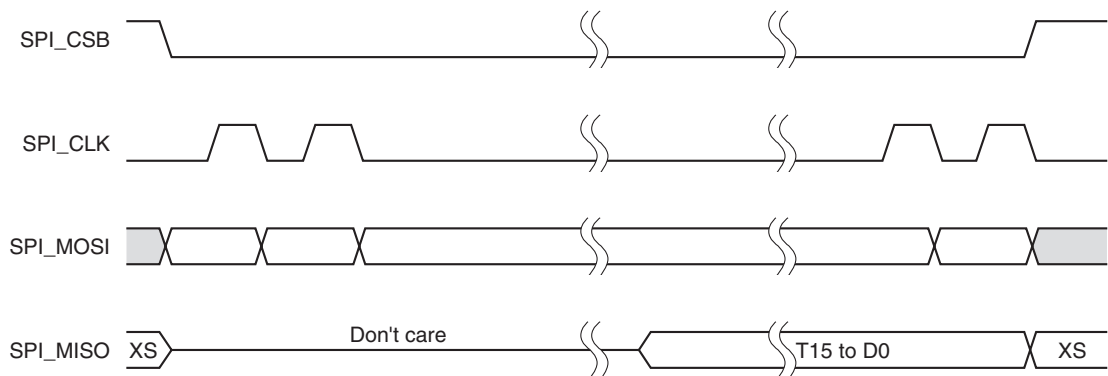

Read Operation B

PCM Interface

The PCM interface of the CXN1010 supports the continuous transmission and reception of PCM data using hardware. This reduces the overhead of processors for wireless headset applications. The CXN1010 provides a bidirectional digital audio interface that is connected directly to the baseband layer of the on-chip firmware. The bidirectional digital audio interface does not pass the HCI protocol layer.

Data can be transmitted and received with one or more SCO connections using the hardware of the CXN1010. The PCM interface supports up to three SCO connections at a time.

The CXN1010 can operate as the PCM interface master for generating an output clock of 128, 256 or 512kHz. Alternatively, when it is set to serve as the PCM interface slave, it can operate using an input clock up to 2048kHz. The CXN1010 can support many different clock types including long frame sync, short frame sync and GCI timings.

In terms of 8k per second sampling, the CXN1010 supports 13- or 16-bit linear, 8-bit μ -Law and 8-bit A-Law companding sample formats. The PCM settings can be performed using the PSKEY_PCM_CONFIG (0x1B3) persistent store key.

PCM Interface Master/Slave

When the CXN1010 is set as the PCM interface master, PCM_CLK and PCM_SYNC are generated.

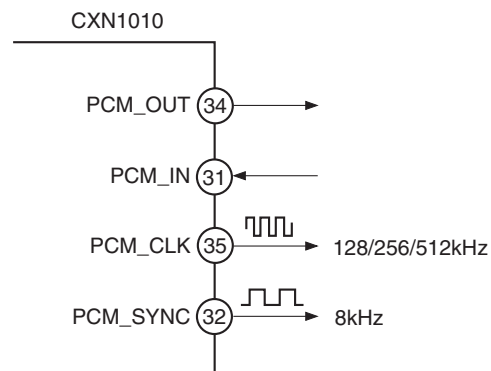

PCM Interface Master

When the CXN1010 is configured as the PCM interface slave, PCM_CLK rates up to 2048kHz are accepted.

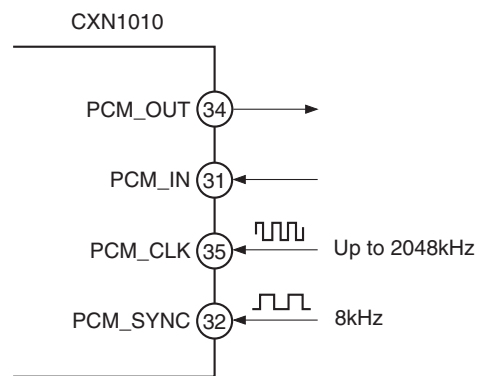

PCM Interface Slave

PIO Port

The parallel input/output (PIO) port serves as the general-purpose I/O interface of the CXN1010. It consists of nine programmable bidirectional I/O lines.

These programmable I/O lines can be accessed via either the installed application run by the CXN1010 or the private channel or manufacturer-designated HCI commands.

PIO[0]/RXEN

This multi-functional terminal is a programmable I/O line. Either the programmable I/O or control output for external LNA (if fitted).

PIO[1]/TXEN

This multi-functional terminal is a programmable I/O line. Either the programmable I/O or control output for external PA Class1 applications only.

PIO[2]/USB_PULL_UP*1

This multi-functional terminal is a programmable I/O line. Either the programmable I/O or PIO or USB pull-up (via 1.5kΩ resistor to USB_D+).

PIO[3]/USB_WAKE_UP*1

This multi-functional terminal is a programmable I/O line. Either the programmable I/O or USB_WAKE_UP function can be selected with the PSKEY_USB_PIO_WAKEUP (0x2CF) persistent store key setting.

PIO[4]/USB_ON*1

This multi-functional terminal is a programmable I/O line. It can also be used as the USB_ON function.

PIO[5]/USB_DETACH*1

This multi-functional terminal is a programmable I/O line. It can also be used as the USB_DETACH function.

PIO[6]/CLK_REQ

This is a multi-functional terminal whose function is determined by the persistent store keys. Using PSKEY_CLOCK_REQUEST_ENABLE (0x246), it can be set to low when the CXN1010 is in deep sleep and to high when a clock is requested. If a shift in the timing in certain operation modes is to be avoided, the clock must be supplied within 4ms from the PIO[6] rising edge.

PIO[7]

Programmable I/O terminal

PIO[8]

Programmable I/O terminal

PIO[9]

Programmable I/O terminal

PIO[10]

Programmable I/O terminal

PIO[11]

Programmable I/O terminal

*1 The USB function can be mapped in the software to any of the PIO terminals.

AIO[0]

Programmable I/O line

AIO[1]

Programmable I/O line

AIO[2]

Programmable I/O line