



CXTILT02EC

HIGH ACCURACY, DIGITAL SERIES

The CXTILT-Series two-axis inclinometers offer an outstanding combination of resolution, dynamic response and measurement accuracy. The integration of MEMS sensing elements and digital signal processing yields a system that requires no user calibration. Resolution and settling time are programmable, allowing the performance to be optimized for a variety of applications.



Platform Leveling



Precision Tilt Measurements

The CXTILT-Series inclinometers measure the tilt angle (roll and pitch) of an object with respect to the horizontal axis in a static environment. These high performance sensors incorporate two micro-machined low-g accelerometers, one oriented along the X-axis and one along the Y-axis.

The CXTILT02EC provides superior performance in demanding measurement applications, where high accuracy must be maintained over a wide temperature range. The CXTILT02E offers a cost effective solution for limited temperature range applications.

Features

- Roll and Pitch Angle Output
- Accuracy <0.2 deg
- User Programmable Resolution and Settling Time
- RS-232 Serial Digital Interface
- Input Voltage 8-30 VDC
- Rugged Aluminum Package

Certifications

- RoHS Compliant

Applications

- Platform Leveling
- Precision Tilt Measurements
- Geo-mechanical Leveling
- Lab Instrumentation

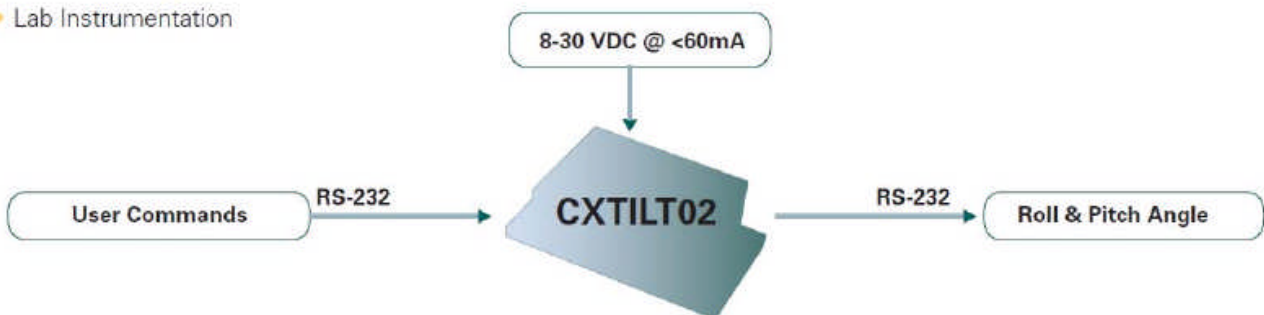



CXTILT02EC

HIGH ACCURACY, DIGITAL SERIES

Performance

CXTILT02EC

Sensor	
Accuracy (°)	± 0.2
Angular Range (°)	± 75
Angular Drift w/Temp (°)	0.7
Angular Resolution (°)	See Filter Settings
Settling Time (s)	See Filter Settings
Null Angular Offset (°)	< 0.5
Non-Linearity (%)	< 0.3
Transverse Sensitivity (%)	1

Specifications

Environment	
Temperature Range (°C)	-40 to +85

Electrical	
RS-232 Interface (Baud)	9600
Supply Voltage (VDC)	8-30
Supply Current (mA)	60

Physical	
Size (in)	4.02 x 2.25 x 1.24
(cm)	10.21 x 5.74 x 3.15
Weight (oz)	5.9
(kg)	0.166
Connector	15 pin sub-miniature high density, male

Standard Package

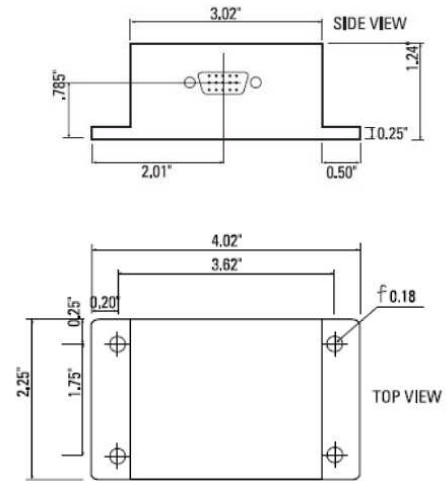

Connector Pin Diagram

Pin	Function
4	Transmit Data
3	Receive Data
1	Ground
11	Input Power

Serial Commands

Command	Function Description/Response
R	Reset. Resets the CXTILT firmware to default settings. An ASCII 'H' (72) is sent in response.
G	Get Angle Data Packet. The CXTILT returns its current angular position. The data is in a 6 byte packet (see content of data packet table).
N<0-9>	Set Resolution Level. A 2byte command sequence that configures the CXTILT's internal digital filter. The second byte, an integer of value 0-9, sets the level of filtering (see filter settings table).
C	Continuous Mode: Transfers packet continuously at maximum rate.
S	Stop Continuous Mode

Content of Data Packet

Byte	Description
0	Header (always 255)
1	Pitch MSB (0-255)
2	Pitch LSB (0-255)
3	Roll MSB (0-255)
4	Roll LSB (0-255)
5	Checksum (8-bit sum of bytes 1-4)

Note: Angles are represented as two's complement 16 bit numbers. +90° corresponds to 32,767. -90° corresponds to -32,768. The 16-bit signed angle can be obtained by this simple 'C' expression: (int) Roll LSB + (int) 256 * Roll MSB

Filter Settings

Filter	Fc(Hz)	Tc(s)	Typical Resolution (°)
0	none	none	0.320
1	10.0	0.016	0.101
2	8.0	0.02	0.091
3	4.0	0.04	0.064
4	2.0	0.08	0.045
5	1.0	0.16	0.032
6	.5	0.32	0.023
7*	0.25	0.64	0.016
8	0.125	1.27	0.012
9	0.0625	2.55	0.009

Ordering Information

Model	Description
CXTILT02EC	Digital Tilt Sensor (-40 to +85°C)

This product has been developed exclusively for commercial applications. It has not been tested for, and makes no representation or warranty as to conformance with, any military specifications or its suitability for any military application or end-use. Additionally, any use of this product for nuclear, chemical or biological weapons, or weapons research, or for any use in missiles, rockets, and/or UAV's of 300km or greater range, or any other activity prohibited by the Export Administration Regulations, is expressly prohibited without the written consent and without obtaining appropriate US export license(s) when required by US law. Diversion contrary to U.S. law is prohibited. Specifications are subject to change without notice.