

Frequency Multiplier and Zero Delay Buffer

Features

- 90 ps typical jitter OUT2
- 200 ps typical jitter OUT1
- 65 ps typical output-to-output skew
- 90 ps typical propagation delay
- Voltage range: 3.3 V ± 5%, or 5 V ± 10%
- Output frequency range: 5 MHz to 133 MHz
- Two outputs
- Configuration options allow various multiplications of the reference frequency – refer to [Configuration Options](#) to determine the specific option which meets your multiplication needs
- Available in 8-pin SOIC package

Configuration Options

FBIN	FS0	FS1	OUT1	OUT2
OUT1	0	0	2 × REF	REF
OUT1	1	0	4 × REF	2 × REF
OUT1	0	1	REF	REF/2
OUT1	1	1	8 × REF	4 × REF
OUT2	0	0	4 × REF	2 × REF
OUT2	1	0	8 × REF	4 × REF
OUT2	0	1	2 × REF	REF
OUT2	1	1	16 × REF	8 × REF

Functional Description

For a complete list of related documentation, click [here](#).

Logic Block Diagram

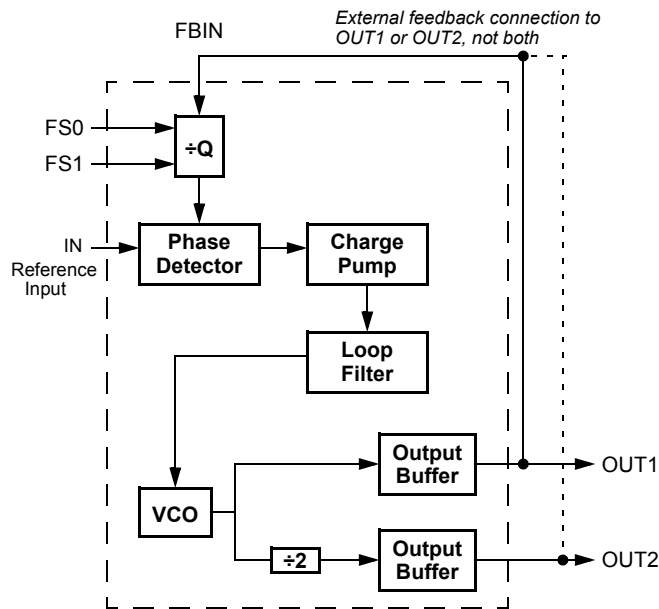

Contents

Pinouts	3	Package Diagram	9
Pin Definitions	3	Acronyms	10
Functional Overview	4	Document Conventions	10
How to Implement Zero Delay	4	Units of Measure	10
Inserting Other Devices in Feedback Path	4	Document History Page	11
Phase Alignment	4	Sales, Solutions, and Legal Information	12
Absolute Maximum Ratings	5	Worldwide Sales and Design Support	12
DC Electrical Characteristics	5	Products	12
DC Electrical Characteristics	5	PSoC® Solutions	12
Thermal Resistance	5	Cypress Developer Community	12
AC Electrical Characteristics	6	Technical Support	12
AC Electrical Characteristics	7		
Ordering Information	8		
Ordering Code Definitions	8		

Pinouts

Figure 1. 8-pin SOIC pinout

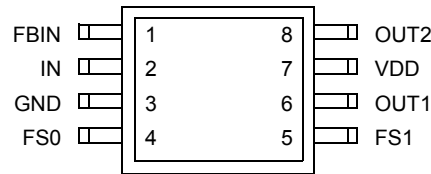

Pin Definitions

Pin Name	Pin No.	Pin Type	Pin Description
IN	2	I	Reference Input: The output signals are synchronized to this signal.
FBIN	1	I	Feedback Input: This input must be fed by one of the outputs (OUT1 or OUT2) to ensure proper functionality. If the trace between FBIN and the output pin being used for feedback is equal in length to the traces between the outputs and the signal destinations, then the signals received at the destinations are synchronized to the REF signal input (IN).
OUT1	6	O	Output 1: The frequency of the signal provided by this pin is determined by the feedback signal connected to FBIN, and the FS0:1 inputs (see Configuration Options on page 1).
OUT2	8	O	Output 2: The frequency of the signal provided by this pin is one-half of the frequency of OUT1. See Configuration Options on page 1 .
VDD	7	P	Power Connections: Connect to 3.3 V or 5 V. This pin should be bypassed with a 0.1- μ F decoupling capacitor. Use ferrite beads to help reduce noise for optimal jitter performance.
GND	3	P	Ground Connection: Connect all grounds to the common system ground plane.
FS0:1	4, 5	I	Function Select Inputs: Tie to V_{DD} (HIGH, 1) or GND (LOW, 0) as desired per Configuration Options on page 1 .

Functional Overview

The CY2302 is a two-output zero delay buffer and frequency multiplier. It provides an external feedback path allowing maximum flexibility when implementing the Zero Delay feature. This is explained further in the sections of this datasheet titled, [How to Implement Zero Delay](#), and [Inserting Other Devices in Feedback Path](#).

The CY2302 is a pin-compatible upgrade of the Cypress W42C70-01. The CY2302 addresses some application dependent problems experienced by users of the older device.

Figure 2. Schematic/Suggested Layout

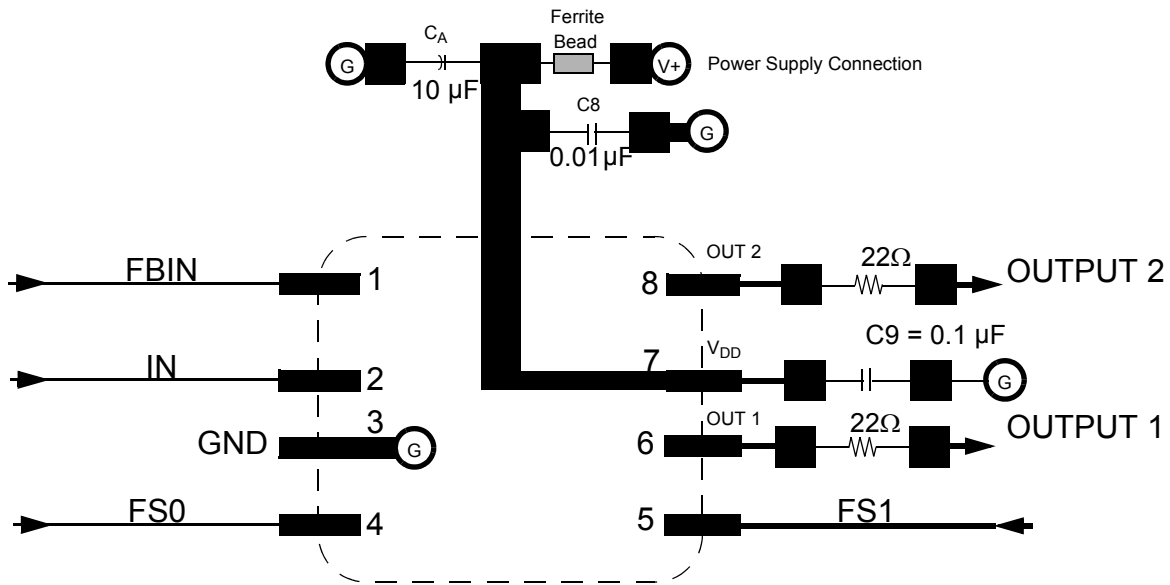

How to Implement Zero Delay

Typically, Zero Delay Buffers (ZDBs) are used because a designer wants to provide multiple copies of a clock signal in phase with each other. The whole concept behind ZDBs is that the signals at the destination chips are all going HIGH at the same time as the input to the ZDB. In order to achieve this, layout must compensate for trace length between the ZDB and the target devices. The method of compensation is described as follows.

External feedback is the trait that allows for this compensation. The PLL on the ZDB causes the feedback signal to be in phase with the reference signal. When laying out the board, match the trace lengths between the output being used for feedback and the FBIN input to the PLL.

If it is desirable to either add a little delay, or slightly precede the input signal, this may also be implemented by either making the trace to the FBIN pin a little shorter or a little longer than the traces to the devices being clocked.

Inserting Other Devices in Feedback Path

Another nice feature available due to the external feedback is the ability to synchronize signals to the signal coming from some other device. This implementation can be applied to any device (ASIC, multiple output clock buffer/driver, etc.) that is put into the feedback path.

Referring to [Figure 2](#), if the traces between the ASIC/Buffer and the destination of the clock signal(s) (A) are equal in length to the

trace between the buffer and the FBIN pin, the signals at the destination(s) device is driven HIGH at the same time when the Reference clock provided to the ZDB goes HIGH. Synchronizing the other outputs of the ZDB to the outputs from the ASIC/Buffer is more complex however, as any propagation delay from the ZDB output to the ASIC/Buffer output must be accounted for.

Figure 3. Six Output Buffer in the Feedback Path

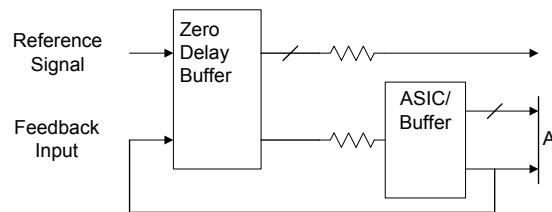

Phase Alignment

In cases where OUT1 (i.e., the higher frequency output) is connected to FBIN input pin the output OUT2 rising edges may be either 0 or 180° phase aligned to the IN input waveform (as set randomly when the input and/or power is supplied). If OUT2 is desired to be rising-edge aligned to the IN input's rising edge, then connect the OUT2 (i.e., the lowest frequency output) to the FBIN pin. This set-up provides a consistent input-output phase relationship.

Absolute Maximum Ratings

Exceeding maximum ratings may shorten the useful life of the device. User guidelines are not tested.

Parameter	Description	Rating	Unit
V_{DD}, V_{IN}	Voltage on any pin with respect to GND	-0.5 to +7.0	V
T_{STG}	Storage temperature	-65 to +150	°C
T_A	Ambient operating temperature, commercial	0 to +70	°C
	Ambient operating temperature, industrial	-40 to +85	°C
T_B	Ambient temperature under bias	-55 to +125	°C
P_D	Power dissipation	0.5	W

DC Electrical Characteristics

$T_A = 0\text{ °C to }70\text{ °C or }-40\text{ °C to }85\text{ °C}, V_{DD} = 3.3\text{ V} \pm 5\%$

Parameter	Description	Test Condition	Min	Typ	Max	Unit
I_{DD}	Supply current	Unloaded, 100 MHz	-	17	35	mA
V_{IL}	Input low voltage	-	-	-	0.8	V
V_{IH}	Input high voltage	-	2.0	-	-	V
V_{OL}	Output low voltage	$I_{OL} = 12\text{ mA}$	-	-	0.4	V
V_{OH}	Output high voltage	$I_{OH} = -12\text{ mA}$	2.4	-	-	V
I_{IL}	Input low current	$V_{IN} = 0\text{ V}$	-40	-	5	μA
I_{IH}	Input high current	$V_{IN} = V_{DD}$	-	-	5	μA

DC Electrical Characteristics

$T_A = 0\text{ °C to }70\text{ °C or }-40\text{ °C to }85\text{ °C}, V_{DD} = 5\text{ V} \pm 10\%$

Parameter	Description	Test Condition	Min	Typ	Max	Unit
I_{DD}	Supply current	Unloaded, 100 MHz	-	37	50	mA
V_{IL}	Input low voltage	-	-	-	0.8	V
V_{IH}	Input high voltage	-	2.0	-	-	V
V_{OL}	Output low voltage	$I_{OL} = 12\text{ mA}$	-	-	0.4	V
V_{OH}	Output high voltage	$I_{OH} = -12\text{ mA}$	2.4	-	-	V
I_{IL}	Input low current	$V_{IN} = 0\text{ V}$	-80	-	5	μA
I_{IH}	Input high current	$V_{IN} = V_{DD}$	-	-	5	μA

Thermal Resistance

Parameter ^[1]	Description	Test Conditions	8-pin SOIC	Unit
θ_{JA}	Thermal resistance (junction to ambient)	Test conditions follow standard test methods and procedures for measuring thermal impedance, in accordance with EIA/JESD51.	132	°C/W
θ_{JC}	Thermal resistance (junction to case)		43	°C/W

Note

- These parameters are guaranteed by design and are not tested.

AC Electrical Characteristics

 $T_A = 0\text{ }^{\circ}\text{C to }+70\text{ }^{\circ}\text{C or }-40\text{ }^{\circ}\text{C to }85\text{ }^{\circ}\text{C, }V_{DD} = 3.3\text{ V} \pm 5\%$ [2]

Parameter	Description	Test Condition	Min	Typ	Max	Unit
f_{IN}	Input Frequency [3]	–	5	–	133	MHz
f_{OUT}	Output Frequency	OUT1 15 pF load	10	–	133	MHz
t_R	Output Rise Time	0.8 V to 2.0 V, 15 pF load	–	–	3.5	ns
t_F	Output Fall Time	2.0 V to 0.8 V, 15 pF load	–	–	2.5	ns
t_{ICKR}	Input Clock Rise Time [4]	–	–	–	10	ns
t_{ICLF}	Input Clock Fall Time [4]	–	–	–	10	ns
t_D	Duty Cycle	15-pF load[5]	40	50	60	%
t_{LOCK}	PLL Lock Time	Power supply stable	–	–	1.0	ms
t_{JC}	Jitter, Cycle-to-Cycle	OUT1, $f_{OUT} > 30$ MHz	–	200	300	ps
		OUT2, $f_{OUT} > 30$ MHz	–	90	300	ps
t_{DC}	Die Out Time[6]	–	100	–	–	Clock Cycles
t_{SKEW}	Output-output Skew[7]	–	–	65	250	ps
t_{PD}	Propagation Delay[7]	–	–350	90	350	ps

Notes

2. All AC specifications are measured with a 50 Ω transmission line, load terminated with 50 Ω to 1.4 V.
3. Input frequency is limited by output frequency range and input to output frequency multiplication factor (which is determined by circuit configuration).
4. Longer input rise and fall time degrades skew and jitter performance.
5. Duty cycle is measured at 1.4 V.
6. 33 MHz reference input suddenly stopped (0 MHz). Number of cycles provided prior to output falling to <16 MHz.
7. Skew is measured at 1.4 V on rising edges.

AC Electrical Characteristics

 $T_A = 0\text{ }^{\circ}\text{C to }+70\text{ }^{\circ}\text{C or }-40\text{ }^{\circ}\text{C to }85\text{ }^{\circ}\text{C, }V_{DD} = 5.0\text{ V } \pm 10\% \text{ [8]}$

Parameter	Description	Test Condition	Min	Typ	Max	Unit
f_{IN}	Input Frequency [9]	–	5	–	133	MHz
f_{OUT}	Output Frequency	OUT1 15 pF load	10	–	133	MHz
t_R	Output Rise Time	0.8 V to 2.0 V, 15 pF load	–	–	2.5	ns
t_F	Output Fall Time	2.0 V to 0.8 V, 15 pF load	–	–	1.5	ns
t_{ICKR}	Input Clock Rise Time [10]	–	–	–	10	ns
t_{ICLF}	Input Clock Fall Time [10]	–	–	–	10	ns
t_D	Duty Cycle	15-pF load [11, 12]	40	50	60	%
t_{LOCK}	PLL Lock Time	Power supply stable	–	–	1.0	ms
t_{JC}	Jitter, Cycle-to-Cycle	OUT1, $f_{OUT} > 30$ MHz	–	200	300	ps
		OUT2, $f_{OUT} > 30$ MHz	–	90	300	ps
t_{DC}	Die out time [13]	–	100	–	–	Clock cycles
t_{SKEW}	Output-output Skew [14]	–	–	65	250	ps
t_{PD}	Propagation Delay [14]	–	–350	90	350	ps

Notes

8. All AC specifications are measured with a 50 Ω transmission line, load terminated with 50 Ω to 1.4 V.
9. Input frequency is limited by output frequency range and input to output frequency multiplication factor (which is determined by circuit configuration).
10. Longer input rise and fall time degrades skew and jitter performance.
11. Duty cycle is measured at 1.4 V.
12. Duty Cycle measured at 120 MHz. For 133 MHz, degrades to 35/65 worst case.
13. 33 MHz reference input suddenly stopped (0 MHz). Number of cycles provided prior to output falling to <16 MHz.
14. Skew is measured at 1.4 V on rising edges.

Ordering Information

Ordering Code	Package Type	Temperature Grade
Pb-free		
CY2302SXC-1	8-pin SOIC	Commercial (0 °C to 70 °C)
CY2302SXC-1T	8-pin SOIC – Tape and Reel	Commercial (0 °C to 70 °C)
CY2302SXI-1	8-pin SOIC	Industrial (–40 °C to 85 °C)
CY2302SXI-1T	8-pin SOIC – Tape and Reel	Industrial (–40 °C to 85 °C)

Ordering Code Definitions

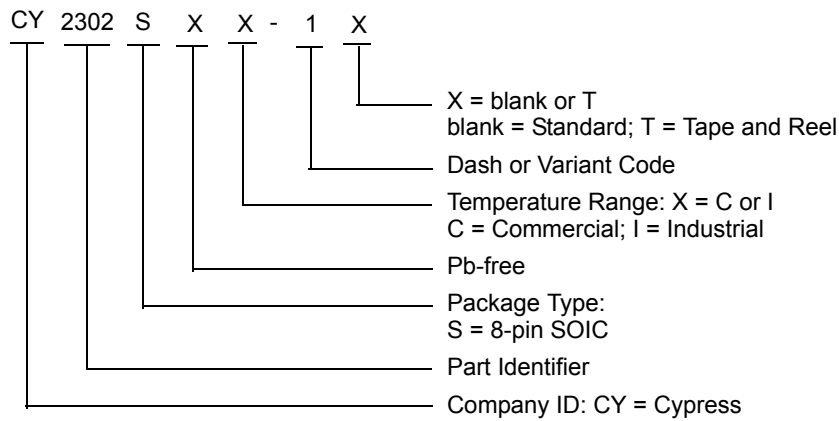

Package Diagram

Figure 4. 8-pin SOIC (150 Mils) S0815/SZ815/SW815 Package Outline, 51-85066

1. DIMENSIONS IN INCHES[MM] MIN. MAX.
2. PIN 1 IS OPTIONAL, ROUND ON SINGLE LEADFRAME RECTANGULAR ON MATRIX LEADFRAME
3. REFERENCE JEDEC MS-012
4. PACKAGE WEIGHT 0.07gms

PART #	
S08.15	STANDARD PKG
SZ08.15	LEAD FREE PKG
SW8.15	LEAD FREE PKG

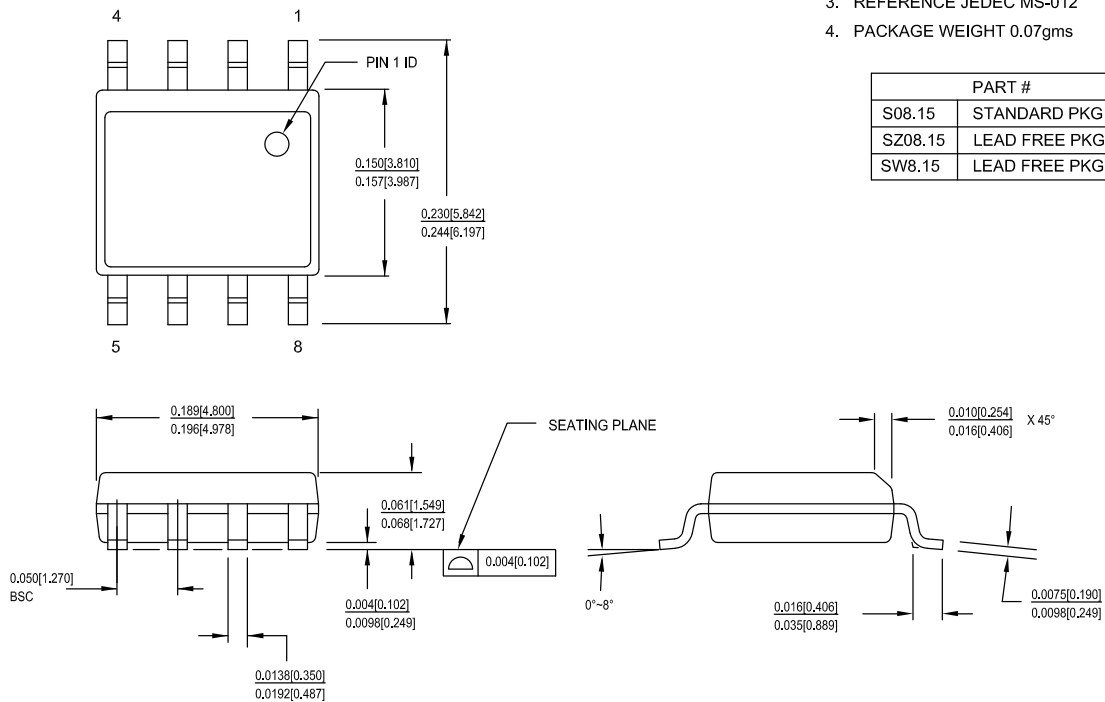

51-85066 *H

Acronyms

Acronym	Description
FBK	Feedback
PLL	Phase Locked Loop
MUX	Multiplexer

Document Conventions

Units of Measure

Symbol	Unit of Measure	Symbol	Unit of Measure
°C	degree Celsius	μW	microwatt
dB	decibel	mA	milliampere
fC	femtocoulomb	mm	millimeter
fF	femtofarad	ms	millisecond
Hz	hertz	mV	millivolt
KB	1024 bytes	nA	nanoampere
Kbit	1024 bits	ns	nanosecond
kHz	kilohertz	nV	nanovolt
kΩ	kilohm	Ω	ohm
MHz	megahertz	ppm	parts per million
MΩ	megaohm	pA	picoampere
μA	microampere	pF	picofarad
μF	microfarad	pp	peak-to-peak
μH	microhenry	ps	picosecond
μs	microsecond	sps	samples per second
μV	microvolt	σ	sigma: one standard deviation
μVrms	microvolts root-mean-square		

Document History Page

Document Title: CY2302, Frequency Multiplier and Zero Delay Buffer Document Number: 38-07154				
Revision	ECN	Orig. of Change	Submission Date	Description of Change
**	110264	SZV	12/18/01	Change from Spec number: 38-00794 to 38-07154
*A	394695	RGL	See ECN	Updated Features : Added typical char data. Updated Functional Overview : Added Phase Alignment . Updated AC Electrical Characteristics . Updated AC Electrical Characteristics . Updated Ordering Information : Updated part numbers.
*B	2761988	KVM	09/10/09	Updated Absolute Maximum Ratings : Updated details in "Description" column corresponding to T _A parameter. Updated Ordering Information : Updated part numbers. Updated details in "Temperature Grade" column (Added temperature values).
*C	2894970	KVM	03/23/2010	Updated Ordering Information : Removed inactive parts. Updated Package Diagram .
*D	2907904	KVM	04/08/2010	Updated Ordering Information : Removed inactive parts.
*E	3204657	BASH	03/24/2011	Added Ordering Code Definitions under Ordering Information . Added Acronyms and Units of Measure .
*F	4348705	CINM	04/16/2014	Updated Package Diagram : spec 51-85066 – Changed revision from *D to *F. Updated to new template. Completing Sunset Review.
*G	4578443	AJU	11/25/2014	Updated Functional Description : Added "For a complete list of related documentation, click here ." at the end.
*H	5275750	PSR	05/18/2016	Added Thermal Resistance . Updated Package Diagram : spec 51-85066 – Changed revision from *F to *H. Updated to new template.
*I	5730303	TAVA	05/08/2017	Updated to new template. Completing Sunset Review.

Sales, Solutions, and Legal Information

Worldwide Sales and Design Support

Cypress maintains a worldwide network of offices, solution centers, manufacturer's representatives, and distributors. To find the office closest to you, visit us at [Cypress Locations](#).

Products

ARM® Cortex® Microcontrollers	cypress.com/arm
Automotive	cypress.com/automotive
Clocks & Buffers	cypress.com/clocks
Interface	cypress.com/interface
Internet of Things	cypress.com/iot
Memory	cypress.com/memory
Microcontrollers	cypress.com/mcu
PSoC	cypress.com/psoc
Power Management ICs	cypress.com/pmic
Touch Sensing	cypress.com/touch
USB Controllers	cypress.com/usb
Wireless Connectivity	cypress.com/wireless

PSoC® Solutions

[PSoC 1](#) | [PSoC 3](#) | [PSoC 4](#) | [PSoC 5LP](#)

Cypress Developer Community

[Forums](#) | [WICED IOT Forums](#) | [Projects](#) | [Video](#) | [Blogs](#) | [Training](#) | [Components](#)

Technical Support

cypress.com/support

© Cypress Semiconductor Corporation, 2001–2017. This document is the property of Cypress Semiconductor Corporation and its subsidiaries, including Spansion LLC ("Cypress"). This document, including any software or firmware included or referenced in this document ("Software"), is owned by Cypress under the intellectual property laws and treaties of the United States and other countries worldwide. Cypress reserves all rights under such laws and treaties and does not, except as specifically stated in this paragraph, grant any license under its patents, copyrights, trademarks, or other intellectual property rights. If the Software is not accompanied by a license agreement and you do not otherwise have a written agreement with Cypress governing the use of the Software, then Cypress hereby grants you a personal, non-exclusive, nontransferable license (without the right to sublicense) (1) under its copyright rights in the Software (a) for Software provided in source code form, to modify and reproduce the Software solely for use with Cypress hardware products, only internally within your organization, and (b) to distribute the Software in binary code form externally to end users (either directly or indirectly through resellers and distributors), solely for use on Cypress hardware product units, and (2) under those claims of Cypress's patents that are infringed by the Software (as provided by Cypress, unmodified) to make, use, distribute, and import the Software solely for use with Cypress hardware products. Any other use, reproduction, modification, translation, or compilation of the Software is prohibited.

TO THE EXTENT PERMITTED BY APPLICABLE LAW, CYPRESS MAKES NO WARRANTY OF ANY KIND, EXPRESS OR IMPLIED, WITH REGARD TO THIS DOCUMENT OR ANY SOFTWARE OR ACCOMPANYING HARDWARE, INCLUDING, BUT NOT LIMITED TO, THE IMPLIED WARRANTIES OF MERCHANTABILITY AND FITNESS FOR A PARTICULAR PURPOSE. To the extent permitted by applicable law, Cypress reserves the right to make changes to this document without further notice. Cypress does not assume any liability arising out of the application or use of any product or circuit described in this document. Any information provided in this document, including any sample design information or programming code, is provided only for reference purposes. It is the responsibility of the user of this document to properly design, program, and test the functionality and safety of any application made of this information and any resulting product. Cypress products are not designed, intended, or authorized for use as critical components in systems designed or intended for the operation of weapons, weapons systems, nuclear installations, life-support devices or systems, other medical devices or systems (including resuscitation equipment and surgical implants), pollution control or hazardous substances management, or other uses where the failure of the device or system could cause personal injury, death, or property damage ("Unintended Uses"). A critical component is any component of a device or system whose failure to perform can be reasonably expected to cause the failure of the device or system, or to affect its safety or effectiveness. Cypress is not liable, in whole or in part, and you shall and hereby do release Cypress from any claim, damage, or other liability arising from or related to all Unintended Uses of Cypress products. You shall indemnify and hold Cypress harmless from and against all claims, costs, damages, and other liabilities, including claims for personal injury or death, arising from or related to any Unintended Uses of Cypress products.

Cypress, the Cypress logo, Spansion, the Spansion logo, and combinations thereof, WICED, PSoC, CapSense, EZ-USB, F-RAM, and Traveo are trademarks or registered trademarks of Cypress in the United States and other countries. For a more complete list of Cypress trademarks, visit cypress.com. Other names and brands may be claimed as property of their respective owners.