

Clock Generator for Intel® Alviso Chipset

Features

- Compliant to Intel® CK410M
- Supports Intel Pentium-M CPU
- Selectable CPU frequencies
- Differential CPU clock pairs
- 100 MHz differential SRC clocks
- 96 MHz differential dot clock
- 48 MHz USB clocks

- 33 MHz PCI clock
- Low-voltage frequency select input
- I²C support with readback capabilities
- Ideal Lexmark Spread Spectrum profile for maximum electromagnetic interference (EMI) reduction
- 3.3V power supply
- 56-pin SSOP and TSSOP packages

CPU	SRC	PCI	REF	DOT96	USB_48
x2 / x3	x7 / x8	x 6	x 1	x 1	x 1

Block Diagram

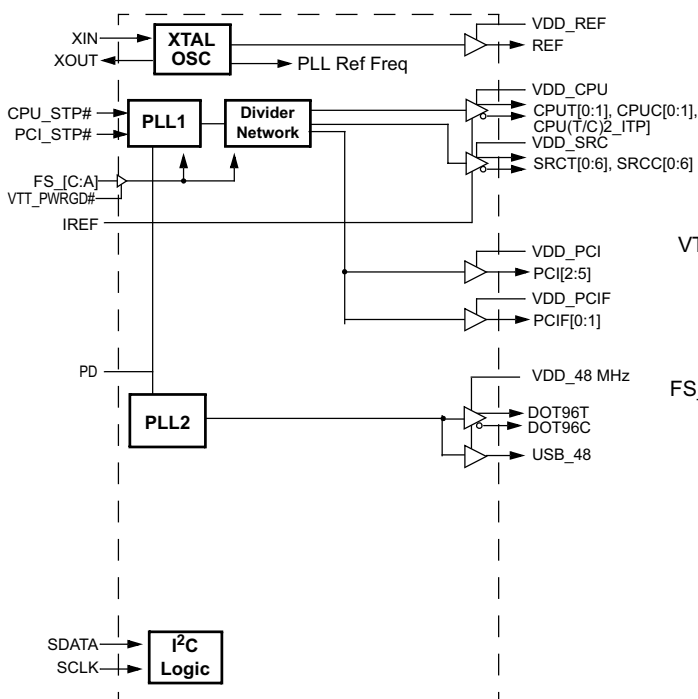

Pin Configuration

VDD_PCI	1	56	PCI2
VSS_PCI	2	55	PCI_STP#
PCI3	3	54	CPU_STP#
PCI4	4	53	FS_C/TEST_SEL
PCI5	5	52	REF
VSS_PCI	6	51	VSS_REF
VDD_PCI	7	50	XIN
PCIF0/ITP_EN	8	49	XOUT
PCIF1	9	48	VDD_REF
VTT_PWRGD#/PD	10	47	SDATA
VDD_48	11	46	SCLK
USB_48/FS_A	12	45	VSS_CPU
VSS_48	13	44	CPUT0
DOT96T	14	43	CPUC0
DOT96C	15	42	VDD_CPU
FS_B/TEST_MODE	16	41	CPUT1
SRCT0	17	40	CPUC1
SRCC0	18	39	IREF
SRCT1	19	38	VSSA
SRCC1	20	37	VDDA
VDD_SRC	21	36	CPUT2_ITP/SRCT7
SRCT2	22	35	CPUC2_ITP/SRCC7
SRCC2	23	34	VDD_SRC
SRCT3	24	33	SRCT6
SRCC3	25	32	SRCC6
SRC4_SATAT	26	31	SRCT5
SRC4_SATAC	27	30	SRCC5
VDD_SRC	28	29	VSS_SRC

56 SSOP/TSSOP

Pin Definitions

Pin No.	Name	Type	Description
54	CPU_STP#	I, PU	3.3V LVTTTL input for CPU_STP# active low.
44,43,41,40	CPUT/C	O, DIF	Differential CPU clock outputs.

Pin Definitions

Pin No.	Name	Type	Description
36,35	CPUT2_ITP/SRCT7, CPUC2_ITP/SRCC7	O, DIF	Selectable differential CPU or SRC clock output. ITP_EN = 0 @ VTT_PWRGD# assertion = SRC7 ITP_EN = 1 @ VTT_PWRGD# assertion = CPU2
14,15	DOT96T, DOT96C	O, DIF	Fixed 96-MHz clock output.
12	FS_A/USB_48	I/O, SE	3.3V-tolerant input for CPU frequency selection/fixed 48-MHz clock output. <i>Refer to DC Electrical Specifications table for V_{il_FS} and V_{ih_FS} specifications.</i>
16	FS_B/TEST_MODE	I	3.3V-tolerant input for CPU frequency selection. Selects Ref/N or Hi-Z when in test mode 0 = Hi-Z, 1 = Ref/N <i>Refer to DC Electrical Specifications table for V_{il_FS} and V_{ih_FS} specifications.</i>
53	FS_C/TEST_SEL	I	3.3V-tolerant input for CPU frequency selection. Selects test mode if pulled to V_{IMFS_C} when VTT_PWRGD# is asserted low. <i>Refer to DC Electrical Specifications table for V_{ILFS_C}, V_{IMFS_C}, V_{IHFS_C} specifications.</i>
39	IREF	I	A precision resistor is attached to this pin, which is connected to the internal current reference.
56,3,4,5	PCI	O, SE	33-MHz clocks.
55	PCI_STP#	I, PU	3.3V LVTTTL input for PCI_STP# active low.
8	PCIF0/ITP_EN	I/O, SE	33-MHz clock/CPU2 select (sampled on the VTT_PWRGD# assertion). 1 = CPU2_ITP, 0 = SRC7
9	PCIF1	O, SE	33-MHz clocks.
52	REF	O, SE	Reference clock. 3.3V 14.318-MHz clock output.
46	SCLK	I	SMBus-compatible SCLOCK.
47	SDATA	I/O	SMBus-compatible SDATA.
26,27	SRC4_SATAT, SRC4_SATAC	O, DIF	Differential serial reference clock. Recommended output for SATA.
24,25,22,23, 19,20,17,18, 33,32,31,30	SRCT/C	O, DIF	Differential serial reference clocks.
11	VDD_48	PWR	3.3V power supply for outputs.
42	VDD_CPU	PWR	3.3V power supply for outputs.
1,7	VDD_PCI	PWR	3.3V power supply for outputs.
48	VDD_REF	PWR	3.3V power supply for outputs.
21,28,34	VDD_SRC	PWR	3.3V power supply for outputs.
37	VDDA	PWR	3.3V power supply for PLL.
13	VSS_48	GND	Ground for outputs.
45	VSS_CPU	GND	Ground for outputs.
2,6	VSS_PCI	GND	Ground for outputs.
51	VSS_REF	GND	Ground for outputs.
29	VSS_SRC	GND	Ground for outputs.
38	VSSA	GND	Ground for PLL.
10	VTT_PWRGD#/PD	I, PU	3.3V LVTTTL input is a level sensitive strobe used to latch the USB_48/FS_A, FS_B, FS_C/TEST_SEL and PCIF0/ITP_EN inputs. After VTT_PWRGD# (active low) assertion, this pin becomes a real-time input for asserting power down (active high).
50	XIN	I	14.318-MHz crystal input.
49	XOUT	O, SE	14.318-MHz crystal output.

Frequency Select Pins (FS_A, FS_B and FS_C)

Host clock frequency selection is achieved by applying the appropriate logic levels to FS_A, FS_B, FS_C inputs prior to VTT_PWRGD# assertion (as seen by the clock synthesizer). Upon VTT_PWRGD# being sampled low by the clock chip (indicating processor VTT voltage is stable), the clock chip samples the FS_A, FS_B and FS_C input values. For all logic levels of FS_A, FS_B and FS_C, VTT_PWRGD# employs a one-shot functionality in that once a valid low on VTT_PWRGD# has been sampled, all further VTT_PWRGD#, FS_A, FS_B and FS_C transitions will be ignored, except in test mode.

Table 1. Frequency Select Table FS_A, FS_B and FS_C

FS_C	FS_B	FS_A	CPU	SRC	PCIF/PCI	REF0	DOT96	USB
MID	0	1	100 MHz	100 MHz	33 MHz	14.318 MHz	96 MHz	48 MHz
0	0	1	133 MHz	100 MHz	33 MHz	14.318 MHz	96 MHz	48 MHz
0	1	1	RESERVED					
0	1	0	200 MHz	100 MHz	33 MHz	14.318 MHz	96 MHz	48 MHz
0	0	0	266 MHz	100 MHz	33 MHz	14.318 MHz	96 MHz	48 MHz
MID	0	0	RESERVED					
MID	1	0						
MID	1	1						
1	0	x	Hi-Z	Hi-Z	Hi-Z	Hi-Z	Hi-Z	Hi-Z
1	1	0	REF/2	REF/8	REF/24	REF	REF	REF
1	1	1	REF/2	REF/8	REF/24	REF	REF	REF

Serial Data Interface

To enhance the flexibility and function of the clock synthesizer, a two-signal serial interface is provided. Through the Serial Data Interface, various device functions, such as individual clock output buffers, can be individually enabled or disabled. The registers associated with the Serial Data Interface initialize to their default setting upon power-up, and therefore use of this interface is optional. Clock device register changes are normally made upon system initialization, if any are required. The interface cannot be used during system operation for power management functions.

Data Protocol

The clock driver serial protocol accepts byte write, byte read, block write, and block read operations from the controller. For block write/read operation, the bytes must be accessed in sequential order from lowest to highest byte (most significant bit first) with the ability to stop after any complete byte has been transferred. For byte write and byte read operations, the system controller can access individually indexed bytes. The offset of the indexed byte is encoded in the command code, as described in *Table 2*.

The block write and block read protocol is outlined in *Table 3* while *Table 4* outlines the corresponding byte write and byte read protocol. The slave receiver address is 11010010 (D2h).

Table 2. Command Code Definition

Bit	Description
7	0 = Block read or block write operation, 1 = Byte read or byte write operation
(6:0)	Byte offset for byte read or byte write operation. For block read or block write operations, these bits should be '0000000'

Table 3. Block Read and Block Write Protocol

Block Write Protocol		Block Read Protocol	
Bit	Description	Bit	Description
1	Start	1	Start
8:2	Slave address – 7 bits	8:2	Slave address – 7 bits
9	Write	9	Write
10	Acknowledge from slave	10	Acknowledge from slave
18:11	Command Code – 8 bits	18:11	Command Code – 8 bits
19	Acknowledge from slave	19	Acknowledge from slave
27:20	Byte Count – 8 bits (Skip this step if I ² C_EN bit set)	20	Repeat start

Table 3. Block Read and Block Write Protocol (continued)

Block Write Protocol		Block Read Protocol	
Bit	Description	Bit	Description
28	Acknowledge from slave	27:21	Slave address – 7 bits
36:29	Data byte 1 – 8 bits	28	Read = 1
37	Acknowledge from slave	29	Acknowledge from slave
45:38	Data byte 2 – 8 bits	37:30	Byte Count from slave – 8 bits
46	Acknowledge from slave	38	Acknowledge
....	Data Byte /Slave Acknowledges	46:39	Data byte 1 from slave – 8 bits
....	Data Byte N –8 bits	47	Acknowledge
....	Acknowledge from slave	55:48	Data byte 2 from slave – 8 bits
....	Stop	56	Acknowledge
		Data bytes from slave / Acknowledge
		Data Byte N from slave – 8 bits
		NOT Acknowledge
		Stop

Table 4. Byte Read and Byte Write Protocol

Byte Write Protocol		Byte Read Protocol	
Bit	Description	Bit	Description
1	Start	1	Start
8:2	Slave address – 7 bits	8:2	Slave address – 7 bits
9	Write	9	Write
10	Acknowledge from slave	10	Acknowledge from slave
18:11	Command Code – 8 bits	18:11	Command Code – 8 bits
19	Acknowledge from slave	19	Acknowledge from slave
27:20	Data byte – 8 bits	20	Repeated start
28	Acknowledge from slave	27:21	Slave address – 7 bits
29	Stop	28	Read
		29	Acknowledge from slave
		37:30	Data from slave – 8 bits
		38	NOT Acknowledge
		39	Stop

Control Registers

Byte 0:Control Register 0

Bit	@Pup	Name	Description
7	1	CPU[T/C]2_ITP/SRCT7 CPUC2_ITP/SRCC7	CPU[T/C]2_ITP/SRC[T/C]7 Output Enable 0 = Disable (Hi-Z), 1 = Enable
6	1	SRC[T/C]6	SRC[T/C]6 Output Enable 0 = Disable (Hi-Z), 1 = Enable
5	1	SRC[T/C]5	SRC[T/C]5 Output Enable 0 = Disable (Hi-Z), 1 = Enable
4	1	SRC[T/C]4	SRC[T/C]4 Output Enable 0 = Disable (Hi-Z), 1 = Enable
3	1	SRC[T/C]3	SRC[T/C]3 Output Enable 0 = Disable (Hi-Z), 1 = Enable

Byte 0: Control Register 0 (continued)

Bit	@Pup	Name	Description
2	1	SRC[T/C]2	SRC[T/C]2 Output Enable 0 = Disable (Hi-Z), 1 = Enable
1	1	SRC[T/C]1	SRC[T/C]1 Output Enable 0 = Disable (Hi-Z), 1 = Enable
0	1	SRC[T/C]0	SRC[T/C]0 Output Enable 0 = Disable (Hi-Z), 1 = Enable

Byte 1: Control Register 1

Bit	@Pup	Name	Description
7	1	PCIF0	PCIF0 Output Enable 0 = Disabled, 1 = Enabled
6	1	DOT_96T/C	DOT_96 MHz Output Enable 0 = Disable (Hi-Z), 1 = Enabled
5	1	USB_48	USB_48 MHz Output Enable 0 = Disabled, 1 = Enabled
4	1	REF	REF Output Enable 0 = Disabled, 1 = Enabled
3	0	Reserved	Reserved
2	1	CPU[T/C]1	CPU[T/C]1 Output Enable 0 = Disable (Hi-Z), 1 = Enabled
1	1	CPU[T/C]0	CPU[T/C]0 Output Enable 0 = Disable (Hi-Z), 1 = Enabled
0	0	CPU/T/C SRCT/C PCIF PCI	Spread Spectrum Enable 0 = Spread off, 1 = Spread on

Byte 2: Control Register 2

Bit	@Pup	Name	Description
7	1	PCI5	PCI5 Output Enable 0 = Disabled, 1 = Enabled
6	1	PCI4	PCI4 Output Enable 0 = Disabled, 1 = Enabled
5	1	PCI3	PCI3 Output Enable 0 = Disabled, 1 = Enabled
4	1	PCI2	PCI2 Output Enable 0 = Disabled, 1 = Enabled
3	1	Reserved	Reserved, Set = 1
2	1	Reserved	Reserved, Set = 1
1	1	Reserved	Reserved, Set = 1
0	1	PCIF1	PCIF1 Output Enable 0 = Disabled, 1 = Enabled

Byte 3: Control Register 3

Bit	@Pup	Name	Description
7	0	SRC7	Allow control of SRC[T/C]7 with assertion of PCI_STP# or SW PCI_STP# 0 = Free running, 1 = Stopped with PCI_STP#
6	0	SRC6	Allow control of SRC[T/C]6 with assertion of PCI_STP# or SW PCI_STP# 0 = Free running, 1 = Stopped with PCI_STP#
5	0	SRC5	Allow control of SRC[T/C]5 with assertion of PCI_STP# or SW PCI_STP# 0 = Free running, 1 = Stopped with PCI_STP#

Byte 3: Control Register 3 (continued)

Bit	@Pup	Name	Description
4	0	SRC4	Allow control of SRC[T/C]4 with assertion of PCI_STP# or SW PCI_STP# 0 = Free running, 1 = Stopped with PCI_STP#
3	0	SRC3	Allow control of SRC[T/C]3 with assertion of PCI_STP# or SW PCI_STP# 0 = Free running, 1 = Stopped with PCI_STP#
2	0	SRC2	Allow control of SRC[T/C]2 with assertion of PCI_STP# or SW PCI_STP# 0 = Free running, 1 = Stopped with PCI_STP#
1	0	SRC1	Allow control of SRC[T/C]1 with assertion of PCI_STP# or SW PCI_STP# 0 = Free running, 1 = Stopped with PCI_STP#
0	0	SRC0	Allow control of SRC[T/C]0 with assertion of PCI_STP# 0 = Free running, 1 = Stopped with PCI_STP#

Byte 4: Control Register 4

Bit	@Pup	Name	Description
7	0	Reserved	Reserved, Set = 0
6	0	DOT96T/C	DOT_PWRDWN Drive Mode 0 = Driven in PWRDWN, 1 = Hi-Z
5	0	Reserved	Reserved, Set = 0
4	0	PCIF1	Allow control of PCIF1 with assertion of PCI_STP# or SW PCI_STP# 0 = Free running, 1 = Stopped with PCI_STP#
3	0	PCIF0	Allow control of PCIF0 with assertion of PCI_STP# or SW PCI_STP# 0 = Free running, 1 = Stopped with PCI_STP#
2	1	CPU[T/C]2	Allow control of CPU[T/C]2 with assertion of CPU_STP# 0 = Free running, 1 = Stopped with CPU_STP#
1	1	CPU[T/C]1	Allow control of CPU[T/C]1 with assertion of CPU_STP# 0 = Free running, 1 = Stopped with CPU_STP#
0	1	CPU[T/C]0	Allow control of CPU[T/C]0 with assertion of CPU_STP# 0 = Free running, 1 = Stopped with CPU_STP#

Byte 5: Control Register 5

Bit	@Pup	Name	Description
7	0	SRC[T/C][7:0]	SRC[T/C] Stop Drive Mode 0 = Driven when PCI_STP# asserted, 1 = Hi-Z when PCI_STP# asserted
6	0	CPU[T/C]2	CPU[T/C]2 Stop Drive Mode 0 = Driven when CPU_STP# asserted, 1 = Hi-Z when CPU_STP# asserted
5	0	CPU[T/C]1	CPU[T/C]1 Stop Drive Mode 0 = Driven when CPU_STP# asserted, 1 = Hi-Z when CPU_STP# asserted
4	0	CPU[T/C]0	CPU[T/C]0 Stop Drive Mode 0 = Driven when CPU_STP# asserted, 1 = Hi-Z when CPU_STP# asserted
3	0	SRC[T/C][7:0]	SRC[T/C] PWRDWN Drive Mode 0 = Driven when PD asserted, 1 = Hi-Z when PD asserted
2	0	CPU[T/C]2	CPU[T/C]2 PWRDWN Drive Mode 0 = Driven when PD asserted, 1 = Hi-Z when PD asserted
1	0	CPU[T/C]1	CPU[T/C]1 PWRDWN Drive Mode 0 = Driven when PD asserted, 1 = Hi-Z when PD asserted
0	0	CPU[T/C]0	CPU[T/C]0 PWRDWN Drive Mode 0 = Driven when PD asserted, 1 = Hi-Z when PD asserted

Byte 6: Control Register 6

Bit	@Pup	Name	Description
7	0		REF/N or Hi-Z Select 0 = Hi-Z, 1 = REF/N Clock
6	0		Test Clock Mode Entry Control 0 = Normal operation, 1 = REF/N or Hi-Z mode,
5	0	Reserved	Reserved, Set = 0
4	1	REF	REF Output Drive Strength 0 = Low, 1 = High
3	1	PCIF, SRC, PCI	SW PCI_STP Function 0=SW PCI_STP assert, 1= SW PCI_STP deassert When this bit is set to 0, all STOPPABLE PCI, PCIF and SRC outputs will be stopped in a synchronous manner with no short pulses. When this bit is set to 1, all STOPPED PCI, PCIF and SRC outputs will resume in a synchronous manner with no short pulses.
2	Externally selected	CPUT/C	FS_C Reflects the value of the FS_C pin sampled on power up 0 = FS_C was low during VTT_PWRGD# assertion
1	Externally selected	CPUT/C	FS_B Reflects the value of the FS_B pin sampled on power up 0 = FS_B was low during VTT_PWRGD# assertion
0	Externally selected	CPUT/C	FS_A Reflects the value of the FS_A pin sampled on power up 0 = FS_A was low during VTT_PWRGD# assertion

Byte 7: Vendor ID

Bit	@Pup	Name	Description
7	0	Revision Code Bit 3	Revision Code Bit 3
6	0	Revision Code Bit 2	Revision Code Bit 2
5	1	Revision Code Bit 1	Revision Code Bit 1
4	0	Revision Code Bit 0	Revision Code Bit 0
3	1	Vendor ID Bit 3	Vendor ID Bit 3
2	0	Vendor ID Bit 2	Vendor ID Bit 2
1	0	Vendor ID Bit 1	Vendor ID Bit 1
0	0	Vendor ID Bit 0	Vendor ID Bit 0

Crystal Recommendations

The CY28411-1 requires a Parallel Resonance Crystal. Substituting a series resonance crystal will cause the CY28411-1 to operate at the wrong frequency and violate the ppm specification. For most applications there is a 300-ppm frequency shift between series and parallel crystals due to incorrect loading.

Crystal Loading

Crystal loading plays a critical role in achieving low ppm performance. To realize low ppm performance, the total capacitance the crystal will see must be considered to calculate the appropriate capacitive loading (CL).

The following diagram shows a typical crystal configuration using the two trim capacitors. An important clarification for the following discussion is that the trim capacitors are in series with the crystal not parallel. It's a common misconception that load capacitors are in parallel with the crystal and should be approximately equal to the load capacitance of the crystal. This is not true.

Table 5. Crystal Recommendations

Frequency (Fund)	Cut	Loading	Load Cap	Drive (max.)	Shunt Cap (max.)	Motional (max.)	Tolerance (max.)	Stability (max.)	Aging (max.)
14.31818 MHz	AT	Parallel	20 pF	0.1 mW	5 pF	0.016 pF	35 ppm	30 ppm	5 ppm

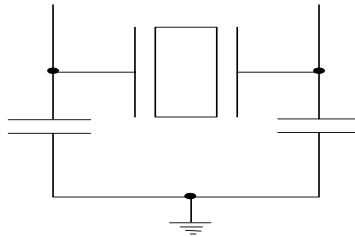
Figure 1. Crystal Capacitive Clarification

Calculating Load Capacitors

In addition to the standard external trim capacitors, trace capacitance and pin capacitance must also be considered to correctly calculate crystal loading. As mentioned previously, the capacitance on each side of the crystal is in series with the

crystal. This means the total capacitance on each side of the crystal must be twice the specified crystal load capacitance (CL). While the capacitance on each side of the crystal is in series with the crystal, trim capacitors (Ce1,Ce2) should be calculated to provide equal capacitive loading on both sides.

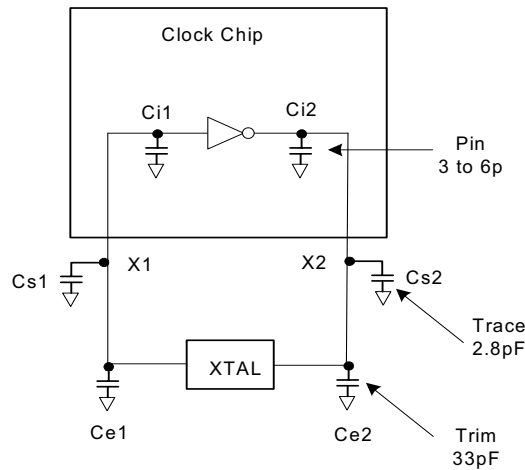
Figure 2. Crystal Loading Example

As mentioned previously, the capacitance on each side of the crystal is in series with the crystal. This mean the total capacitance on each side of the crystal must be twice the specified load capacitance (CL). While the capacitance on each side of the crystal is in series with the crystal, trim capacitors (Ce1,Ce2) should be calculated to provide equal capacitance loading on both sides.

Use the following formulas to calculate the trim capacitor values for Ce1 and Ce2.

Load Capacitance (each side)

$$C_e = 2 * CL - (C_s + C_i)$$

Total Capacitance (as seen by the crystal)

$$CL_e = \frac{1}{\left(\frac{1}{C_{e1} + C_{s1} + C_{i1}} + \frac{1}{C_{e2} + C_{s2} + C_{i2}} \right)}$$

- CL.....Crystal load capacitance
- CL_e..... Actual loading seen by crystal using standard value trim capacitors
- C_e..... External trim capacitors
- C_s..... Stray capacitance (terraced)
- C_i Internal capacitance (lead frame, bond wires etc.)
- CL.....Crystal load capacitance
- CL_e..... Actual loading seen by crystal using standard value trim capacitors
- C_e..... External trim capacitors
- C_s..... Stray capacitance (terraced)
- C_i Internal capacitance (lead frame, bond wires etc.)

PD (Power-down) Clarification

The VTT_PWRGD#/PD pin is a dual function pin. During initial power-up, the pin functions as VTT_PWRGD#. Once VTT_PWRGD# has been sampled low by the clock chip, the pin assumes PD functionality. The PD pin is an asynchronous active high input used to shut off all clocks cleanly prior to shutting off power to the device. This signal is synchronized internal to the device prior to powering down the clock synthesizer. PD is also an asynchronous input for powering up the system. When PD is asserted high, all clocks need to be driven to a low value and held prior to turning off the VCOs and the crystal oscillator.

PD (Power-down) – Assertion

When PD is sampled high by two consecutive rising edges of CPUC, all single-ended outputs will be held low on their next

high to low transition and differential clocks must held high or Hi-Zd (depending on the state of the control register drive mode bit) on the next diff clock# high to low transition within four clock periods. When the SMBus PD drive mode bit corresponding to the differential (CPU, SRC, and DOT) clock output of interest is programmed to '0', the clock output are held with "Diff clock" pin driven high at 2 x Iref, and "Diff clock#" tri-state. If the control register PD drive mode bit corresponding to the output of interest is programmed to "1", then both the "Diff clock" and the "Diff clock#" are tristate. Note the example below shows CPUT = 133 MHz and PD drive mode = '1' for all differential outputs. This diagram and description is applicable to valid CPU frequencies 100,133,166,200,266,333 and 400MHz. In the event that PD mode is desired as the initial power-on state, PD must be asserted high in less than 10 μ S after asserting Vtt_PwrGd#.

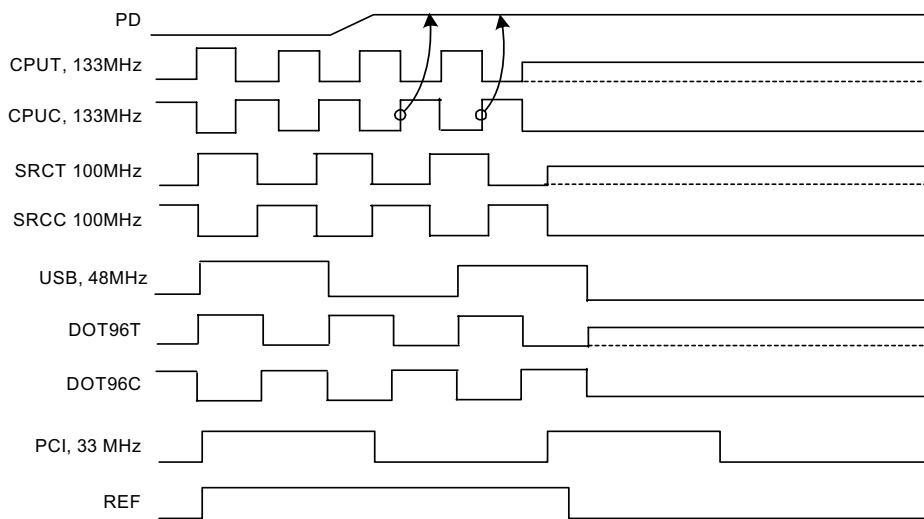

Figure 3. Power-down Assertion Timing Waveform

PD Deassertion

The power-up latency is less than 1.8 ms. This is the time from the deassertion of the PD pin or the ramping of the power supply until the time that stable clocks are output from the clock chip. All differential outputs stopped in a three-state

condition resulting from power down will be driven high in less than 300 μ S of PD deassertion to a voltage greater than 200 mV. After the clock chip's internal PLL is powered up and locked, all outputs will be enabled within a few clock cycles of each other. Below is an example showing the relationship of clocks coming up.

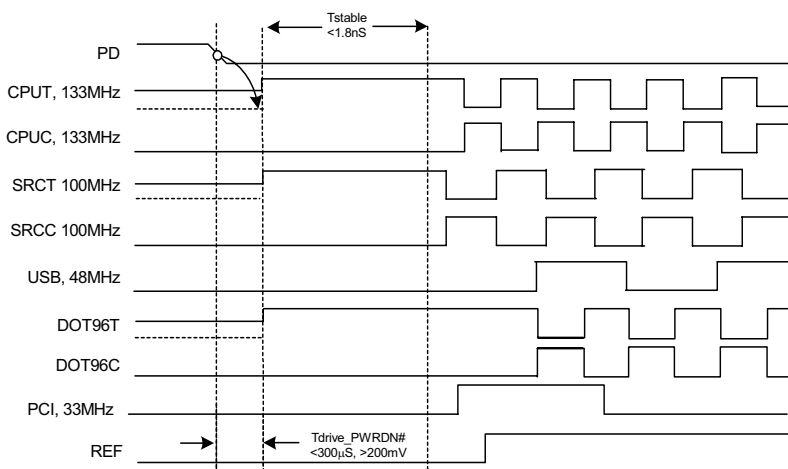

Figure 4. Power-down Deassertion Timing Waveform

CPU_STP# Assertion

The CPU_STP# signal is an active low input used for synchronous stopping and starting the CPU output clocks while the rest of the clock generator continues to function. When the CPU_STP# pin is asserted, all CPU outputs that are set with the SMBus configuration to be stoppable via assertion of CPU_STP# will be stopped within two–six CPU clock

periods after being sampled by two rising edges of the internal CPUC clock. The final states of the stopped CPU signals are CPUT = HIGH and CPUC = LOW. There is no change to the output drive current values during the stopped state. The CPUT is driven HIGH with a current value equal to $6 \times (I_{ref})$, and the CPUC signal will be Hi-Z.

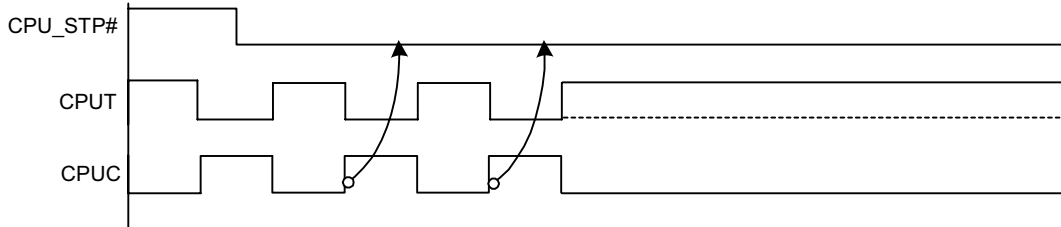

Figure 5. CPU_STP# Assertion Waveform

CPU_STP# Deassertion

The deassertion of the CPU_STP# signal will cause all CPU outputs that were stopped to resume normal operation in a synchronous manner. Synchronous manner meaning that no short or stretched clock pulses will be produced when the clock resumes. The maximum latency from the deassertion to active outputs is no more than two CPU clock cycles.

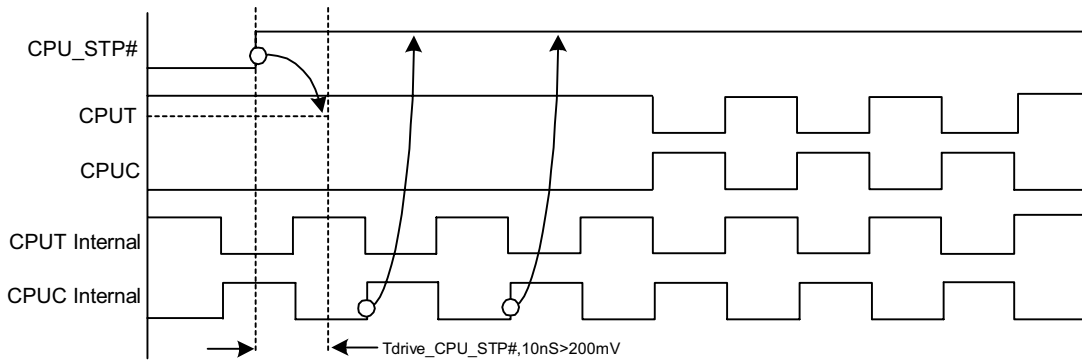

Figure 6. CPU_STP# Deassertion Waveform

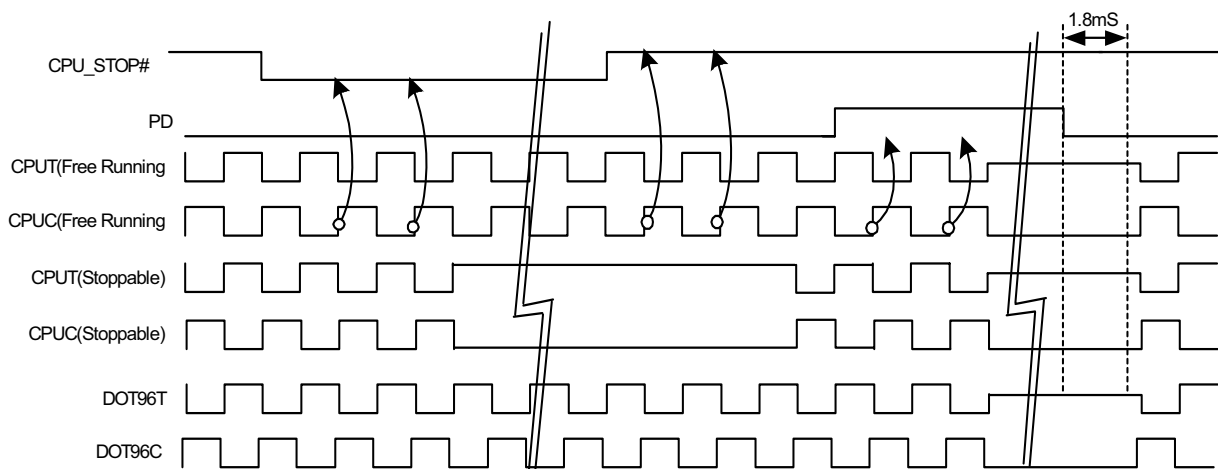

Figure 7. CPU_STP# = Driven, CPU_PD = Driven, DOT_PD = Driven

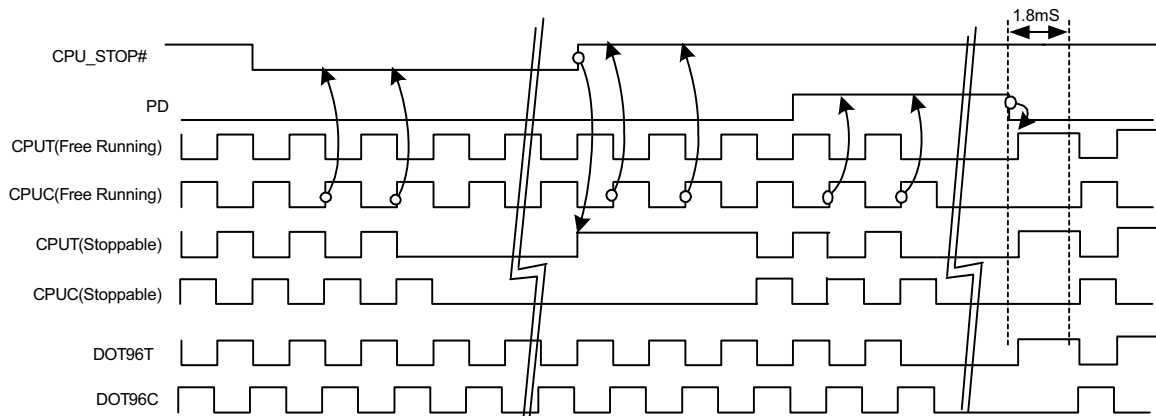

Figure 8. CPU_STP# = Hi-Z, CPU_PD = Hi-Z, DOT_PD = tHi-Z

PCI_STP# Assertion^[1]

The PCI_STP# signal is an active LOW input used for synchronous stopping and starting the PCI outputs while the rest of the clock generator continues to function. The set-up

time for capturing PCI_STP# going LOW is 10 ns (t_{SU}). (See Figure 9.) The PCIF clocks will not be affected by this pin if their corresponding control bit in the SMBus register is set to allow them to be free running.

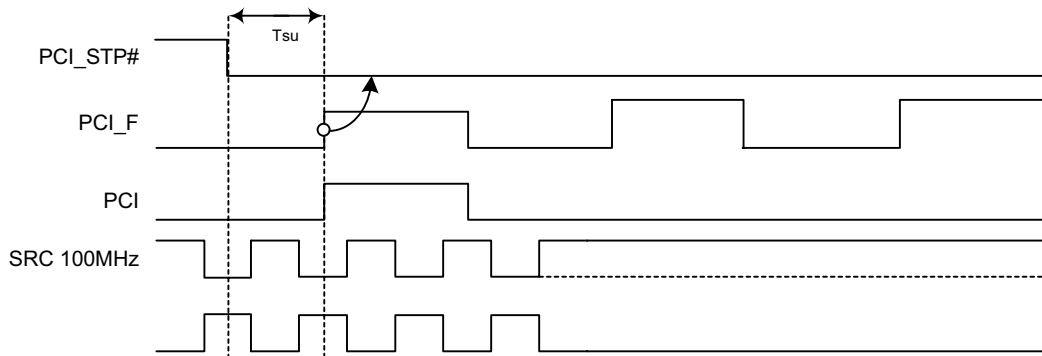

Figure 9. PCI_STP# Assertion Waveform

PCI_STP# Deassertion

The deassertion of the PCI_STP# signal will cause all PCI and stoppable PCIF clocks to resume running in a synchronous manner within two PCI clock periods after PCI_STP# transitions to a high level.

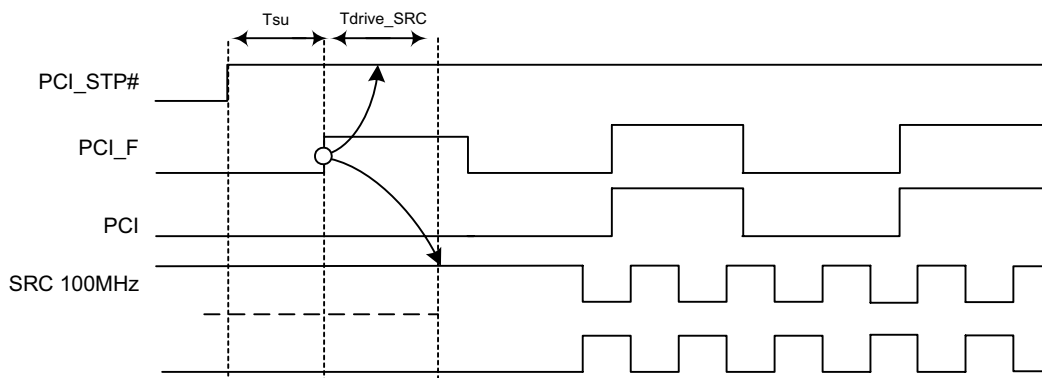

Figure 10. PCI_STP# Deassertion Waveform

Note:

1. The PCI STOP function is controlled by two inputs. One is the device PCI_STP# pin number 34 and the other is SMBus byte 0 bit 3. These two inputs are logically OR'ed. If either the external pin or the internal SMBus register bit is set low then the stoppable PCI clocks will be stopped in a logic low state. Reading SMBus Byte 0 Bit 3 will return a 0 value if either of these control bits are set LOW thereby indicating the device's stoppable PCI clocks are not running.

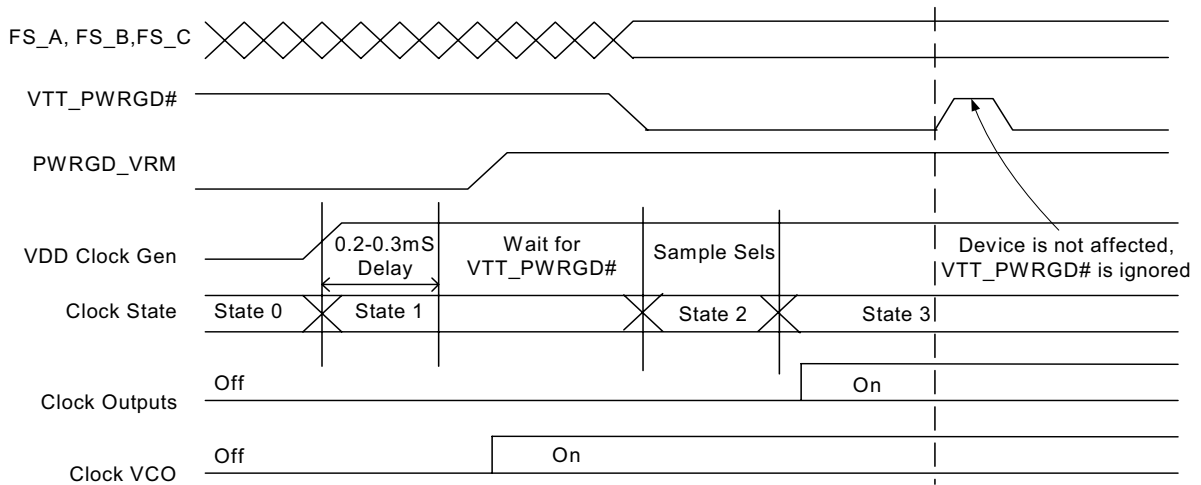

Figure 11. VTT_PWRGD# Timing Diagram

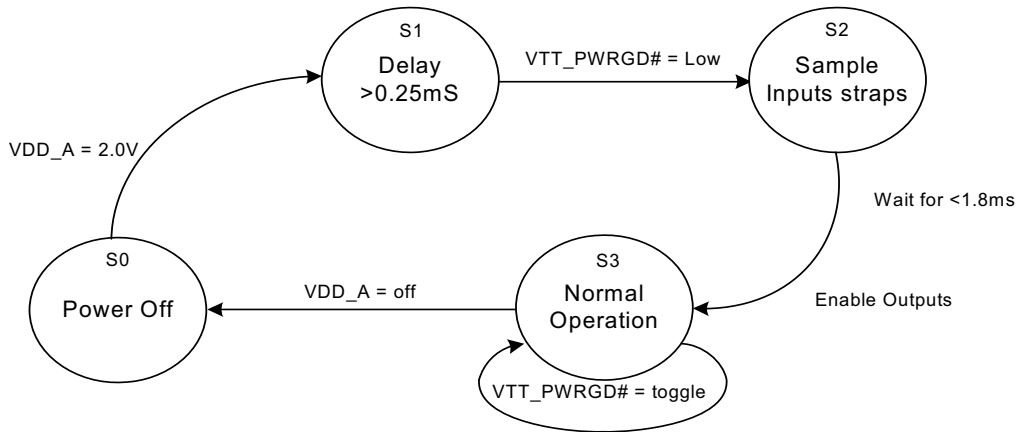

Figure 12. Clock Generator Power-up/Run State Diagram

Absolute Maximum Conditions

Parameter	Description	Condition	Min.	Max.	Unit
V _{DD}	Core Supply Voltage		-0.5	4.6	V
V _{DD_A}	Analog Supply Voltage		-0.5	4.6	V
V _{IN}	Input Voltage	Relative to V _{SS}	-0.5	V _{DD} + 0.5	VDC
T _S	Temperature, Storage	Non-functional	-65	150	°C
T _A	Temperature, Operating Ambient	Functional	0	85	°C
T _J	Temperature, Junction	Functional	-	150	°C
∅ _{JC}	Dissipation, Junction to Case (Mil-Spec 883E Method 1012.1)	SSOP		39.56	°C/W
		TSSOP		20.62	
∅ _{JA}	Dissipation, Junction to Ambient JEDEC (JESD 51)	SSOP		45.29	°C/W
		TSSOP		62.26	
ESD _{HBM}	ESD Protection (Human Body Model)	MIL-STD-883, Method 3015	2000	-	V
UL-94	Flammability Rating	At 1/8 in.		V-0	
MSL	Moisture Sensitivity Level			1	

Multiple Supplies: The voltage on any input or I/O pin cannot exceed the power pin during power-up. Power supply sequencing is NOT required.

DC Electrical Specifications

Parameter	Description	Condition	Min.	Max.	Unit
V _{DD_A} , V _{DD_REF} , V _{DD_PCI} , V _{DD_3V66} , V _{DD_48} , V _{DD_CPU}	3.3V Operating Voltage	3.3 ± 5%	3.135	3.465	V
V _{IL12C}	Input Low Voltage	SDATA, SCLK	-	1.0	V
V _{IH12C}	Input High Voltage	SDATA, SCLK	2.2	-	V
V _{IL_FS}	FS_A/FS_B Input Low Voltage		V _{SS} - 0.3	0.35	V
V _{IH_FS}	FS_A/FS_B Input High Voltage		0.7	V _{DD} + 0.5	V
V _{ILFS_C}	FS_C Low Range		0	0.35	V
V _{IMFS_C}	FS_C Mid Range		0.7	1.7	V
V _{IHFS_C}	FS_C High Range		2.1	V _{DD}	V
V _{IL}	3.3V Input Low Voltage		V _{SS} - 0.5	0.8	V
V _{IH}	3.3V Input High Voltage		2.0	V _{DD} + 0.5	V
I _{IL}	Input Low Leakage Current	except internal pull-up resistors, 0 < V _{IN} < V _{DD}	-5	-	μA
I _{IH}	Input High Leakage Current	except internal pull-down resistors, 0 < V _{IN} < V _{DD}	-	5	μA
V _{OL}	3.3V Output Low Voltage	I _{OL} = 1 mA	-	0.4	V
V _{OH}	3.3V Output High Voltage	I _{OH} = -1 mA	2.4	-	V
I _{OZ}	High-impedance Output Current		-10	10	μA
C _{IN}	Input Pin Capacitance		2	5	pF
C _{OUT}	Output Pin Capacitance		3	6	pF
L _{IN}	Pin Inductance		-	7	nH
V _{XIH}	Xin High Voltage		0.7V _{DD}	V _{DD}	V
V _{XIL}	Xin Low Voltage		0	0.3V _{DD}	V
I _{DD3.3V}	Dynamic Supply Current	At max. load and freq. per <i>Figure 14</i>	-	550	mA
I _{PD3.3V}	Power-down Supply Current	PD asserted, Outputs driven	-	70	mA
I _{PD3.3V}	Power-down Supply Current	PD asserted, Outputs Hi-Z	-	2	mA

AC Electrical Specifications

Parameter	Description	Condition	Min.	Max.	Unit
Crystal					
T _{DC}	XIN Duty Cycle	The device will operate reliably with input duty cycles up to 30/70 but the REF clock duty cycle will not be within specification	47.5	52.5	%
T _{PERIOD}	XIN Period	When XIN is driven from an external clock source	69.841	71.0	ns
T _R / T _F	XIN Rise and Fall Times	Measured between 0.3V _{DD} and 0.7V _{DD}	–	10.0	ns
T _{CCJ}	XIN Cycle to Cycle Jitter	As an average over 1-μs duration	–	500	ps
L _{ACC}	Long-term Accuracy	Over 150 ms	–	300	ppm
CPU at 0.7V					
T _{DC}	CPUT and CPUC Duty Cycle	Measured at crossing point V _{OX}	45	55	%
T _{PERIOD}	100-MHz CPUT and CPUC Period	Measured at crossing point V _{OX}	9.997001	10.00300	ns
T _{PERIOD}	133-MHz CPUT and CPUC Period	Measured at crossing point V _{OX}	7.497751	7.502251	ns
T _{PERIODSS}	100-MHz CPUT and CPUC Period, SSC	Measured at crossing point V _{OX}	9.997001	10.05327	ns
T _{PERIODSS}	133-MHz CPUT and CPUC Period, SSC	Measured at crossing point V _{OX}	7.497751	7.539950	ns
T _{PERIODAbs}	100-MHz CPUT and CPUC Absolute period	Measured at crossing point V _{OX}	9.912001	10.08800	ns
T _{PERIODAbs}	133-MHz CPUT and CPUC Absolute period	Measured at crossing point V _{OX}	7.412751	7.587251	ns
T _{PERIODSSAbs}	100-MHz CPUT and CPUC Absolute period, SSC	Measured at crossing point V _{OX}	9.912001	10.13827	ns
T _{PERIODSSAbs}	133-MHz CPUT and CPUC Absolute period, SSC	Measured at crossing point V _{OX}	7.412751	7.624950	ns
T _{CCJ}	CPUT/C Cycle to Cycle Jitter	Measured at crossing point V _{OX}	–	85	ps
T _{CCJ2}	CPU2_ITP Cycle to Cycle Jitter	Measured at crossing point V _{OX}	–	125	ps
T _{SKEW2}	CPU2_ITP to CPU0 Clock Skew	Measured at crossing point V _{OX}	–	150	ps
T _R / T _F	CPUT and CPUC Rise and Fall Times	Measured from V _{OL} = 0.175 to V _{OH} = 0.525V	175	700	ps
T _{RFM}	Rise/Fall Matching	Determined as a fraction of $2 * (T_R - T_F) / (T_R + T_F)$	–	20	%
ΔT _R	Rise Time Variation		–	125	ps
ΔT _F	Fall Time Variation		–	125	ps
V _{HIGH}	Voltage High	Math averages <i>Figure 14</i>	660	850	mV
V _{LOW}	Voltage Low	Math averages <i>Figure 14</i>	–150	–	mV
V _{OX}	Crossing Point Voltage at 0.7V Swing		250	550	mV
V _{OVS}	Maximum Overshoot Voltage		–	V _{HIGH} + 0.3	V
V _{UDS}	Minimum Undershoot Voltage		–0.3	–	V
V _{RB}	Ring Back Voltage	See <i>Figure 14</i> . Measure SE	–	0.2	V
SRC					
T _{DC}	SRCT and SRCC Duty Cycle	Measured at crossing point V _{OX}	45	55	%
T _{PERIOD}	100-MHz SRCT and SRCC Period	Measured at crossing point V _{OX}	9.997001	10.00300	ns
T _{PERIODSS}	100-MHz SRCT and SRCC Period, SSC	Measured at crossing point V _{OX}	9.997001	10.05327	ns
T _{PERIODAbs}	100-MHz SRCT and SRCC Absolute Period	Measured at crossing point V _{OX}	10.12800	9.872001	ns
T _{PERIODSSAbs}	100-MHz SRCT and SRCC Absolute Period, SSC	Measured at crossing point V _{OX}	9.872001	10.17827	ns
T _{SKEW}	Any SRCT/C to SRCT/C Clock Skew	Measured at crossing point V _{OX}	–	250	ps

AC Electrical Specifications (continued)

Parameter	Description	Condition	Min.	Max.	Unit
T _{CCJ}	SRCT/C Cycle to Cycle Jitter	Measured at crossing point V _{OX}	–	125	ps
L _{ACC}	SRCT/C Long Term Accuracy	Measured at crossing point V _{OX}	–	300	ppm
T _R / T _F	SRCT and SRCC Rise and Fall Times	Measured from V _{OL} = 0.175 to V _{OH} = 0.525V	175	700	ps
T _{RFM}	Rise/Fall Matching	Determined as a fraction of 2 * (T _R – T _F)/(T _R + T _F)	–	20	%
ΔT _R	Rise Time Variation		–	125	ps
ΔT _F	Fall Time Variation		–	125	ps
V _{HIGH}	Voltage High	Math averages <i>Figure 14</i>	660	850	mV
V _{LOW}	Voltage Low	Math averages <i>Figure 14</i>	–150	–	mV
V _{OX}	Crossing Point Voltage at 0.7V Swing		250	550	mV
V _{OVS}	Maximum Overshoot Voltage		–	V _{HIGH} + 0.3	V
V _{UDS}	Minimum Undershoot Voltage		–0.3	–	V
V _{RB}	Ring Back Voltage	See <i>Figure 14</i> . Measure SE	–	0.2	V
PCI/PCIF					
T _{DC}	PCI Duty Cycle	Measurement at 1.5V	45	55	%
T _{PERIOD}	Spread Disabled PCIF/PCI Period	Measurement at 1.5V	29.99100	30.00900	ns
T _{PERIODSS}	Spread Enabled PCIF/PCI Period, SSC	Measurement at 1.5V	29.9910	30.15980	ns
T _{PERIODAbs}	Spread Disabled PCIF/PCI Period	Measurement at 1.5V	29.49100	30.50900	ns
T _{PERIODSSAbs}	Spread Enabled PCIF/PCI Period, SSC	Measurement at 1.5V	29.49100	30.65980	ns
T _{HIGH}	PCIF and PCI high time	Measurement at 2.4V	12.0	–	ns
T _{LOW}	PCIF and PCI low time	Measurement at 0.4V	12.0	–	ns
T _R / T _F	PCIF and PCI rise and fall times	Measured between 0.8V and 2.0V	1.0	4.0	V/ns
T _{SKEW}	Any PCI clock to Any PCI clock Skew	Measurement at 1.5V	–	500	ps
T _{CCJ}	PCIF and PCI Cycle to Cycle Jitter	Measurement at 1.5V	–	500	ps
DOT					
T _{DC}	DOT96T and DOT96C Duty Cycle	Measured at crossing point V _{OX}	45	55	%
T _{PERIOD}	DOT96T and DOT96C Period	Measured at crossing point V _{OX}	10.41354	10.41979	ns
T _{PERIODAbs}	DOT96T and DOT96C Absolute Period	Measured at crossing point V _{OX}	10.16354	10.66979	ns
T _{CCJ}	DOT96T/C Cycle to Cycle Jitter	Measured at crossing point V _{OX}	–	250	ps
L _{ACC}	DOT96T/C Long Term Accuracy	Measured at crossing point V _{OX}	–	100	ppm
T _R / T _F	DOT96T and DOT96C Rise and Fall Times	Measured from V _{OL} = 0.175 to V _{OH} = 0.525V	175	700	ps
T _{RFM}	Rise/Fall Matching	Determined as a fraction of 2 * (T _R – T _F)/(T _R + T _F)	–	20	%
ΔT _R	Rise Time Variation		–	125	ps
ΔT _F	Fall Time Variation		–	125	ps
V _{HIGH}	Voltage High	Math averages <i>Figure 14</i>	660	850	mV
V _{LOW}	Voltage Low	Math averages <i>Figure 14</i>	–150	–	mV
V _{OX}	Crossing Point Voltage at 0.7V Swing		250	550	mV
V _{OVS}	Maximum Overshoot Voltage		–	V _{HIGH} + 0.3	V
V _{UDS}	Minimum Undershoot Voltage		–0.3	–	V
V _{RB}	Ring Back Voltage	See <i>Figure 14</i> . Measure SE	–	0.2	V
USB					
T _{DC}	Duty Cycle	Measurement at 1.5V	45	55	%

AC Electrical Specifications (continued)

Parameter	Description	Condition	Min.	Max.	Unit
T _{PERIOD}	Period	Measurement at 1.5V	20.83125	20.83542	ns
T _{PERIODAbs}	Absolute Period	Measurement at 1.5V	20.48125	21.18542	ns
T _{HIGH}	USB high time	Measurement at 2.4V	8.094	10.036	ns
T _{LOW}	USB low time	Measurement at 0.4V	7.694	9.836	ns
T _R / T _F	Rise and Fall Times	Measured between 0.8V and 2.0V	1.0	2.0	V/ns
T _{CCJ}	Cycle to Cycle Jitter	Measurement at 1.5V	–	350	ps
REF					
T _{DC}	REF Duty Cycle	Measurement at 1.5V	45	55	%
T _{PERIOD}	REF Period	Measurement at 1.5V	69.8203	69.8622	ns
T _{PERIODAbs}	REF Absolute Period	Measurement at 1.5V	68.82033	70.86224	ns
T _R / T _F	REF Rise and Fall Times	Measured between 0.8V and 2.0V	1.0	4.0	V/ns
T _{CCJ}	REF Cycle to Cycle Jitter	Measurement at 1.5V	–	1000	ps
ENABLE/DISABLE and SET-UP					
T _{STABLE}	Clock Stabilization from Power-up		–	1.8	ms
T _{SS}	Stopclock Set-up Time		10.0	–	ns
T _{SH}	Stopclock Hold Time		0	–	ns

Test and Measurement Set-up
For PCI Single-ended Signals and Reference

The following diagram shows the test load configurations for the single-ended PCI, USB, and REF output signals.

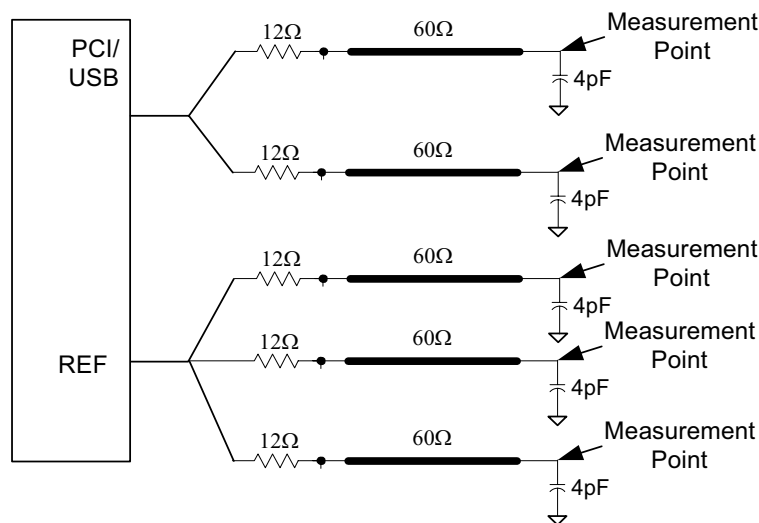
Figure 13. Single-ended Load Configuration

For Differential CPU, SRC and DOT96 Output Signals

The following diagram shows the test load configuration for the differential CPU and SRC outputs.

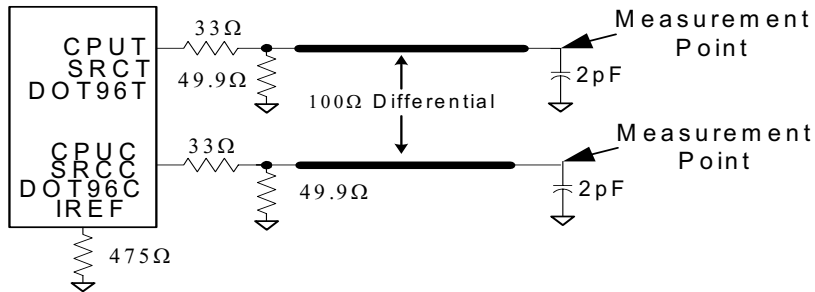

Figure 14. 0.7V Single-ended Load Configuration

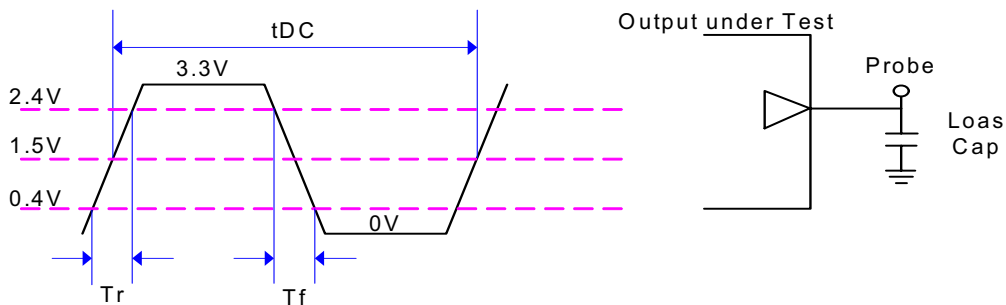

Figure 15. Single-ended Output Signals (for AC Parameters Measurement)

Ordering Information

Part Number	Package Type	Product Flow
Lead-free		
CY28411OXC-1	56-pin SSOP	Commercial, 0° to 85°C
CY28411OXC-1T	56-pin SSOP – Tape and Reel	Commercial, 0° to 85°C
CY28411ZXC-1	56-pin TSSOP	Commercial, 0° to 85°C
CY28411ZXC-1T	56-pin TSSOP – Tape and Reel	Commercial, 0° to 85°C

Package Drawing and Dimensions

56-Lead Thin Shrunk Small Outline Package, Type II (6 mm x 12 mm) Z56

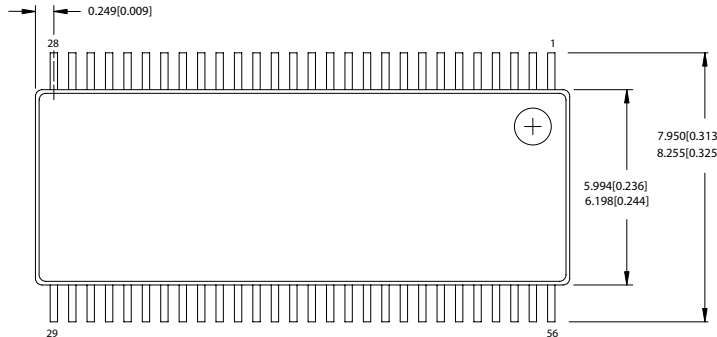

DIMENSIONS IN MM [INCHES] MIN. MAX.

REFERENCE JEDEC MO-153
PACKAGE WEIGHT 0.42gms

PART #
Z5624 STANDARD PKG.
ZZ5624 LEAD FREE PKG.

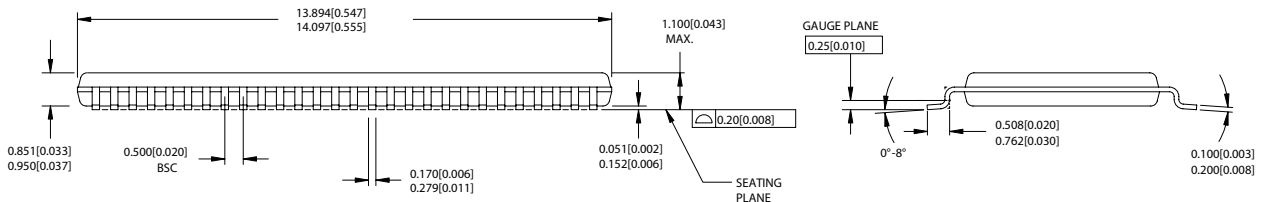

56-Lead Shrunk Small Outline Package O56

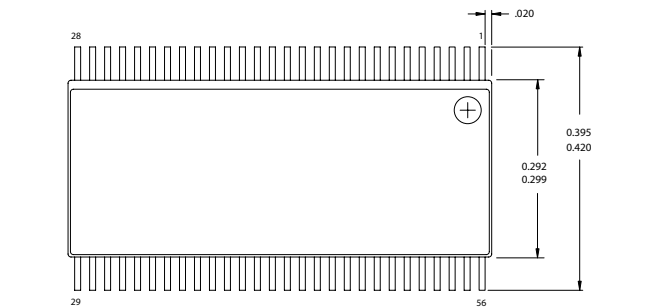

DIMENSIONS IN INCHES MIN. MAX.

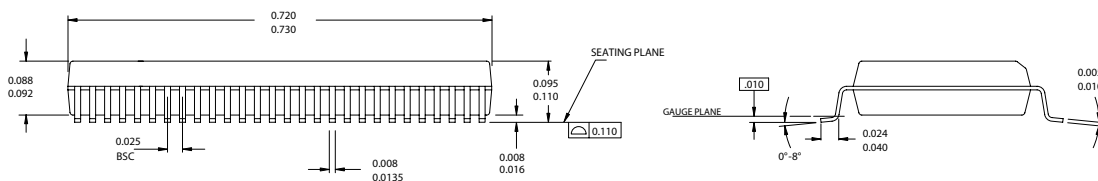

While SLI has reviewed all information herein for accuracy and reliability, Spectra Linear Inc. assumes no responsibility for the use of any circuitry or for the infringement of any patents or other rights of third parties which would result from each use. This product is intended for use in normal commercial applications and is not warranted nor is it intended for use in life support, critical medical instruments, or any other application requiring extended temperature range, high reliability, or any other extraordinary environmental requirements unless pursuant to additional processing by Spectra Linear Inc., and expressed written agreement by Spectra Linear Inc. Spectra Linear Inc. reserves the right to change any circuitry or specification without notice.