

**PRELIMINARY****CY3650/CY3651****USB Developer's Kit****USB Development System on the PC includes:**

- USB development board
- Wall transformer power supply (+6V DC, center negative)
- USB cable
- RS-232 serial cable
- 9-pin male to 25-pin female adapter for RS-232 cable
- Registration Card
- USB Development System User's Guide
- USB Development System Software Guide
- USB Development System Software (3 disks)
- CYASM Assembler software (1 disk)
- Example USB application software included on Assembler disk

Features

- **Full development and debug environment for Cypress Universal Serial Bus Controllers:**
 - Real-time, full-speed emulation
 - Software breakpoints
 - Single stepping
 - Register, RAM, I/O display/modification
- Debug environment operates without firmware modification
- User code can be run from on-board EPROM or RAM
- Stand-alone operation requires only power connection
- Access to key microcontroller internal signals to enable trace and complex breakpoints
- USB Specification Version 1.1 compliant, 1.5 Mbps speed
- Emulator Board Support for Cypress USB IC family:
- **CY3650**
 - CY7C63000/1, 20-pin DIP/SOIC, Windowed DIP
 - CY7C63100/1, 24-pin SOIC, Windowed DIP
 - CY7C63200/1, 18-pin DIP, Windowed DIP
- **CY3651**
 - CY7C63410/1/2, 40-pin PDIP/48-pin SSOP
 - CY7C63413, 40-pin PDIP, 48-pin SSOP, 40-pin Windowed DIP
 - CY7C63510/1/2, 48-pin SSOP
 - CY7C63513, 48-pin SSOP, 48-pin Windowed DIP

Introduction

The Cypress USB Developer's Kit is a powerful tool that enables customers to develop USB hardware and firmware with emulated Cypress USB ICs. The development system can be run in two modes. In the typical development system environment, the board is controlled through a PC-based interface. Software running on the PC facilitates debugging through breakpoints, single stepping, and display and modification of

registers and data RAM. In this mode, firmware can be implemented in on-board EPROM, or downloaded to program RAM. The RAM option provides a quick and easy method for testing firmware revisions.

There is also a stand-alone mode which allows portable system operation without the PC attached. In this mode, user firmware is programmed in an EPROM, and only power need be applied to produce a fully operating emulated USB chip.

Additionally, the board may be connected to a logic analyzer to facilitate full trace capability and complex breakpoints.

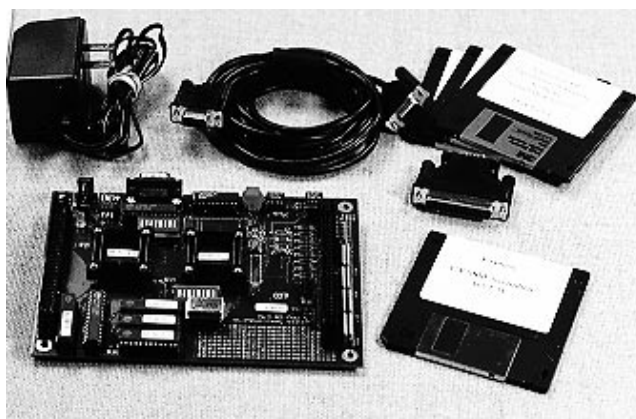
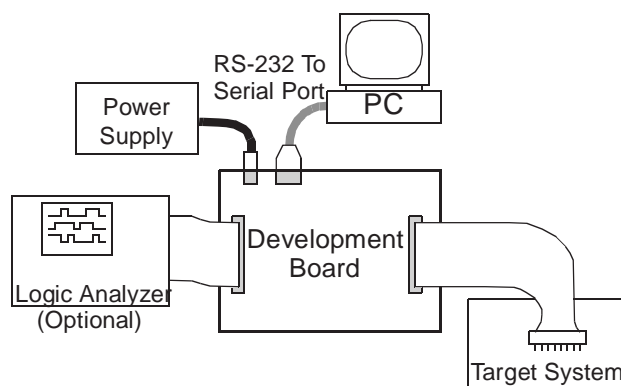
**USB Development System****Typical USB Development Environment**

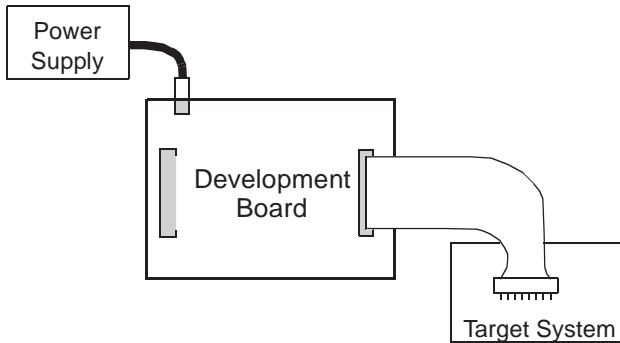

Stand-Alone Environment

Hardware Installation

The development system is simple to install and get running. An enclosed 110 VAC wall transformer supplies power to the board. (Alternatively, a lab power source can be used.) Once the included software is installed on a Windows 3.1 or Windows '95 PC, an RS-232 cable connects the board to that PC to provide a full debug and monitoring environment. The cable and adapters support both a 9-pin and a 25-pin serial port on the PC.

Functional Overview

A block diagram of the development board is shown below, illustrating the major system components and the user interfaces. The microcontroller, USB serial interface protocol engine, and general purpose I/O logic are contained in FPGAs. The board supports a family of Cypress USB ICs, with varying amounts of on-chip EPROM, RAM, and I/O. Consult the individual device data sheets for details of the IC being emulated.

The Program RAM allows users to download code into on-board memory. This provides a quick and easy mechanism for firmware modification. The firmware can be modified after download by changing individual bytes of code through the debug interface. The CY3650 board supports program memory sizes up to 4 KB and the CY3651 board supports program memory sizes up to 8 KB; consult the data sheet of the actual target device for the ROM size contained in the IC.

For stand-alone operation, user firmware can be burned into the supplied UV-erasable EPROM, allowing for operation without the PC attached.

USB Interface

The CY3650 and CY3651 development boards support the low-speed (1.5 Mbps) USB mode, with a 1.5-k Ω pull-up resistor to +3.3V on the D- line for proper operation.

The USB serial interface protocol engine contains the functions commonly referred to as "Serial Interface Engine" and "Serial Interface Logic" in USB literature. This provides full functionality for connecting to a USB bus as a low-speed device, including endpoint control and automatic NAKing.

I/O Port Operation

The general-purpose I/O ports on the board all operate identically. As outputs, the ports provide either a (removable) weak pull-up, or a strong pull-down. During a read operation, the digital state of all bits of each port are read together. All bits also have the capability to serve as interrupt inputs, as described in the device data sheets.

The versatile 4-bit current-sink DAC per pin, available in many Cypress USB family ICs, is not implemented on the board. Support is available for customers who wish to fully emulate this IC feature

Note : The input thresholds are lower (1.5 V) for the development board than the USB parts (45%–65% V_{CC}).

CY3650/51 Development Board Functional Block Diagram

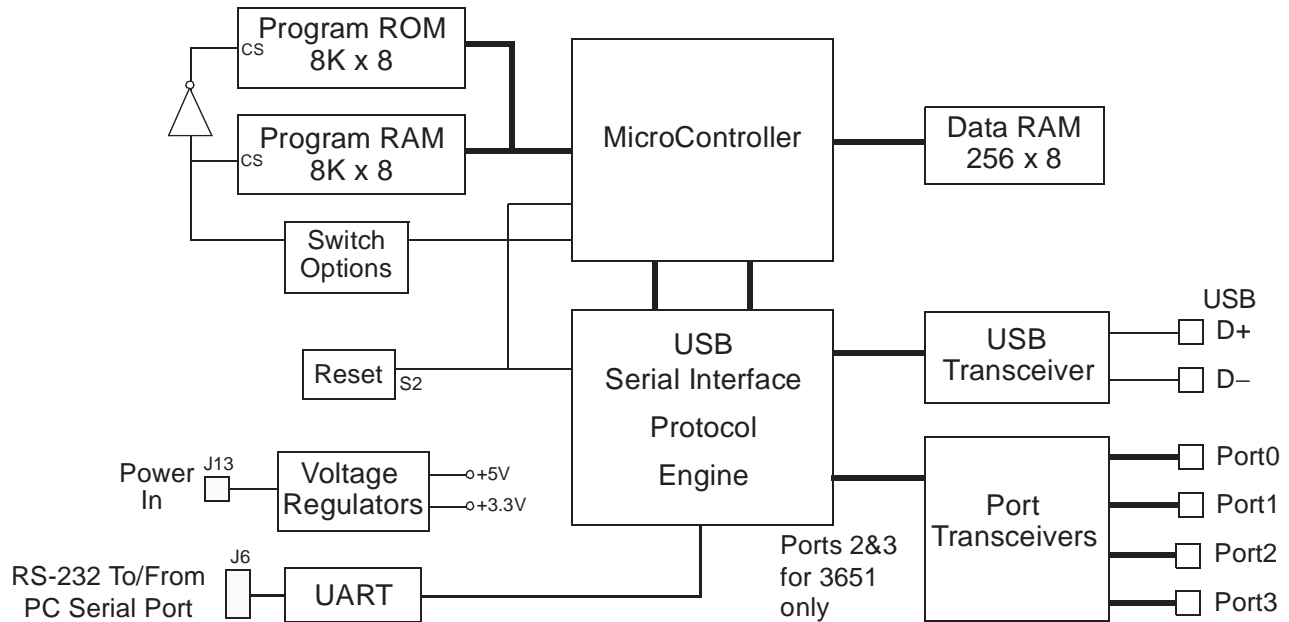

Signal Access

The development board contains connectors to internal micro-controller signals and to the emulated I/O pins. A target cable can be made by the user for the appropriate IC being emulated.

Debug/Monitor Software

The developer’s kit software provides a PC interface for debug control of the microcontroller and all memory and registers. The debug/monitor function is implemented in hardware, so modification of the user firmware is not required.

The software allows read/modify access to the following: all microcontroller internal registers (such as accumulator and program counters), data RAM, program RAM (or non-modifiable EPROM), and all I/O registers. The system allows for multiple breakpoints and single stepping. At any breakpoint, all requested data fields are automatically updated, and the list file tracking moves to the current program line. *Figure 1* shows the debug software window in a typical application.

The software runs under Windows 95 or Windows 3.1. The only setting that the user needs to provide is the proper COM port for communication on the serial port and which development board is being used.

Assembler

An assembler, which also runs on the PC, is included. The assembler provides error checking and produces downloadable object code as well as a list file. The assembler supports USB-specific data types, speeding the development process.

Ordering information

Part Number	Description
CY3650	USB Developer’s Kit
CY3651	USB Developer’s Kit

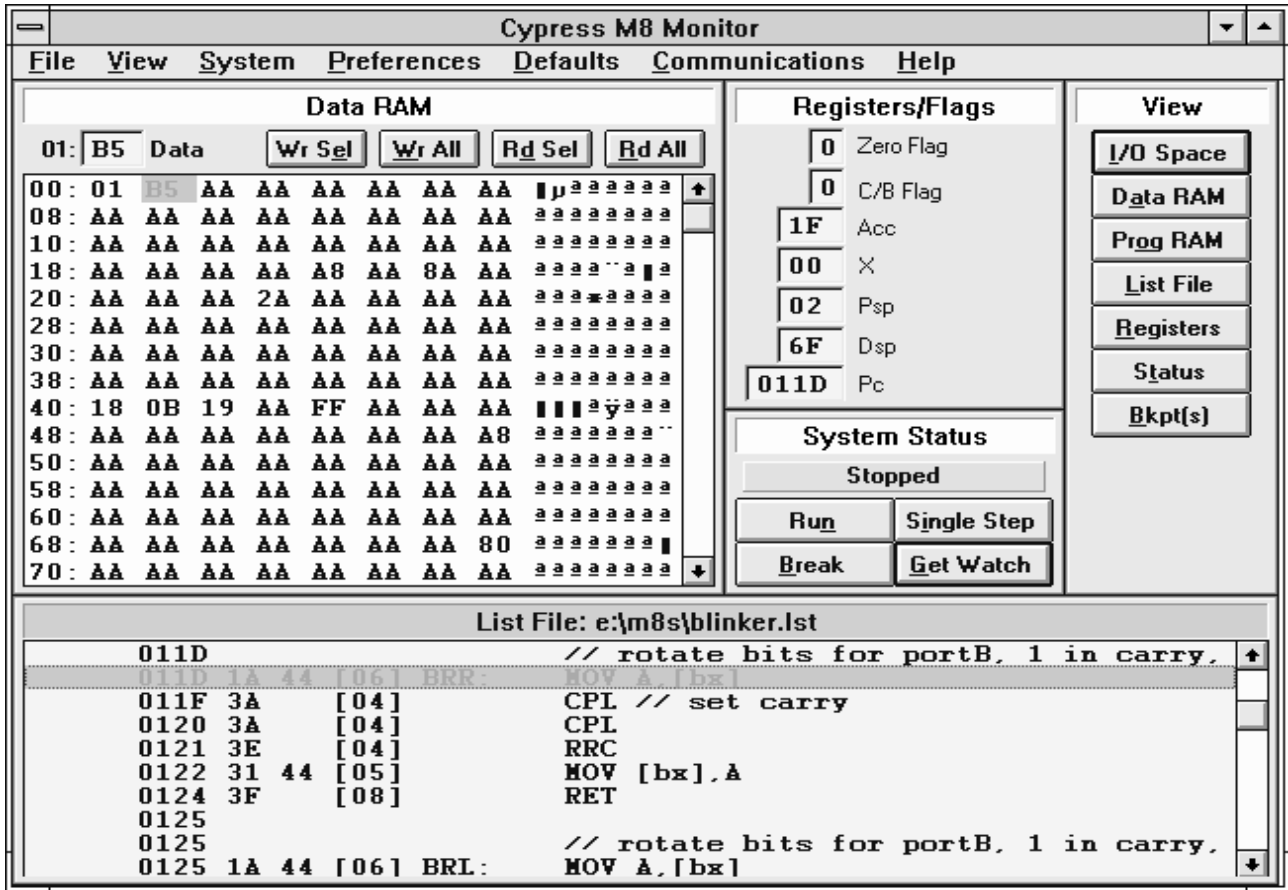

Cypress M8 Monitor

File View System Preferences Defaults Communications Help

Data RAM

Address	Op	Data	Wr Sel	Wr All	Rd Sel	Rd All	Hex	Ascii
00:	01	B5	AA	AA	AA	AA	AA	µ a a a a a a a
08:	AA	AA	AA	AA	AA	AA	AA	a a a a a a a a
10:	AA	AA	AA	AA	AA	AA	AA	a a a a a a a a
18:	AA	AA	AA	AA	A0	AA	0A	a a a a ' ' a a
20:	AA	AA	AA	2A	AA	AA	AA	a a a a a a a a
28:	AA	AA	AA	AA	AA	AA	AA	a a a a a a a a
30:	AA	AA	AA	AA	AA	AA	AA	a a a a a a a a
38:	AA	AA	AA	AA	AA	AA	AA	a a a a a a a a
40:	18	0B	19	AA	FF	AA	AA	a y a a a
48:	AA	AA	AA	AA	AA	AA	A8	a a a a a a a a
50:	AA	AA	AA	AA	AA	AA	AA	a a a a a a a a
58:	AA	AA	AA	AA	AA	AA	AA	a a a a a a a a
60:	AA	AA	AA	AA	AA	AA	AA	a a a a a a a a
68:	AA	AA	AA	AA	AA	AA	80	a a a a a a a
70:	AA	AA	AA	AA	AA	AA	AA	a a a a a a a a

Registers/Flags

0 Zero Flag
 0 C/B Flag
 1F Acc
 00 X
 02 Psp
 6F Dsp
 011D Pc

System Status

Stopped

Run Single Step
 Break Get Watch

View

I/O Space
 Data RAM
 Prog RAM
 List File
 Registers
 Status
 Bkpt(s)

List File: e:\m8s\blinker.lst

```

011D // rotate bits for portB, 1 in carry,
011D 1A 44 [06] BRR: MOV A,[bx]
011F 3A [04] CPL // set carry
0120 3A [04] CPL
0121 3E [04] RRC
0122 31 44 [05] MOV [bx],A
0124 3F [08] RET
0125
0125 // rotate bits for portB, 1 in carry,
0125 1A 44 [06] BRL: MOV A,[bx]
```

Figure 1. Debug Software Window in Typical Application

Document #: 38-00553-B