



CYPRESS

PRELIMINARY

CY62167DV18

MoBL2™

16M (1024K x 16) Static RAM

Features

- **Very high speed: 55 ns and 70 ns**
- **Voltage range: 1.65V to 1.95V**
- **Ultra-low active power**
 - Typical active current: 1.5 mA @ f = 1 MHz
 - Typical active current: 15 mA @ f = f_{MAX}
- **Ultra-low standby power**
- **Easy memory expansion with CE₁, CE₂ and OE** features
- **Automatic power-down when deselected**
- **CMOS for optimum speed/power**
- **Packages offered in a 48-ball FBGA**

Functional Description^[1]

The CY62167DV18 is a high-performance CMOS static RAM organized as 1024K words by 16 bits. This device features advanced circuit design to provide ultra-low active current. This is ideal for providing More Battery Life™ (MoBL®) in portable applications such as cellular telephones. The device also has an automatic power-down feature that significantly reduces power consumption by 99% when addresses are not

toggling. The device can be put into standby mode reducing power consumption by more than 99% when deselected Chip Enable 1 (\overline{CE}_1) HIGH or Chip Enable 2 (CE_2) LOW or both BHE and BLE are HIGH. The input/output pins (I/O₀ through I/O₁₅) are placed in a high-impedance state when: deselected Chip Enable 1 (\overline{CE}_1) HIGH or Chip Enable 2 (CE_2) LOW, outputs are disabled (\overline{OE} HIGH), both Byte High Enable and Byte Low Enable are disabled (\overline{BHE} , BLE HIGH) or during a write operation (Chip Enable 1 (\overline{CE}_1) LOW and Chip Enable 2 (CE_2) HIGH and WE LOW).

Writing to the device is accomplished by taking Chip Enable 1 (\overline{CE}_1) LOW and Chip Enable 2 (CE_2) HIGH and Write Enable (WE) input LOW. If Byte Low Enable (\overline{BLE}) is LOW, then data pins (A₀ through A₁₉). If Byte High Enable (BHE) is LOW, then data from I/O pins (I/O₈ through I/O₁₅) is written into the location specified on the address.

Reading from the device is accomplished by taking Chip Enable 1 (\overline{CE}_1) LOW and Chip Enable 2 (CE_2) HIGH and Output Enable (\overline{OE}) LOW while forcing the Write Enable (WE) HIGH. If Byte Low Enable (\overline{BLE}) is LOW, then data from memory will appear on I/O₈ to I/O₁₅. See the truth table at the back of this data sheet for a complete description of read and write modes.

DataSheet4U.com

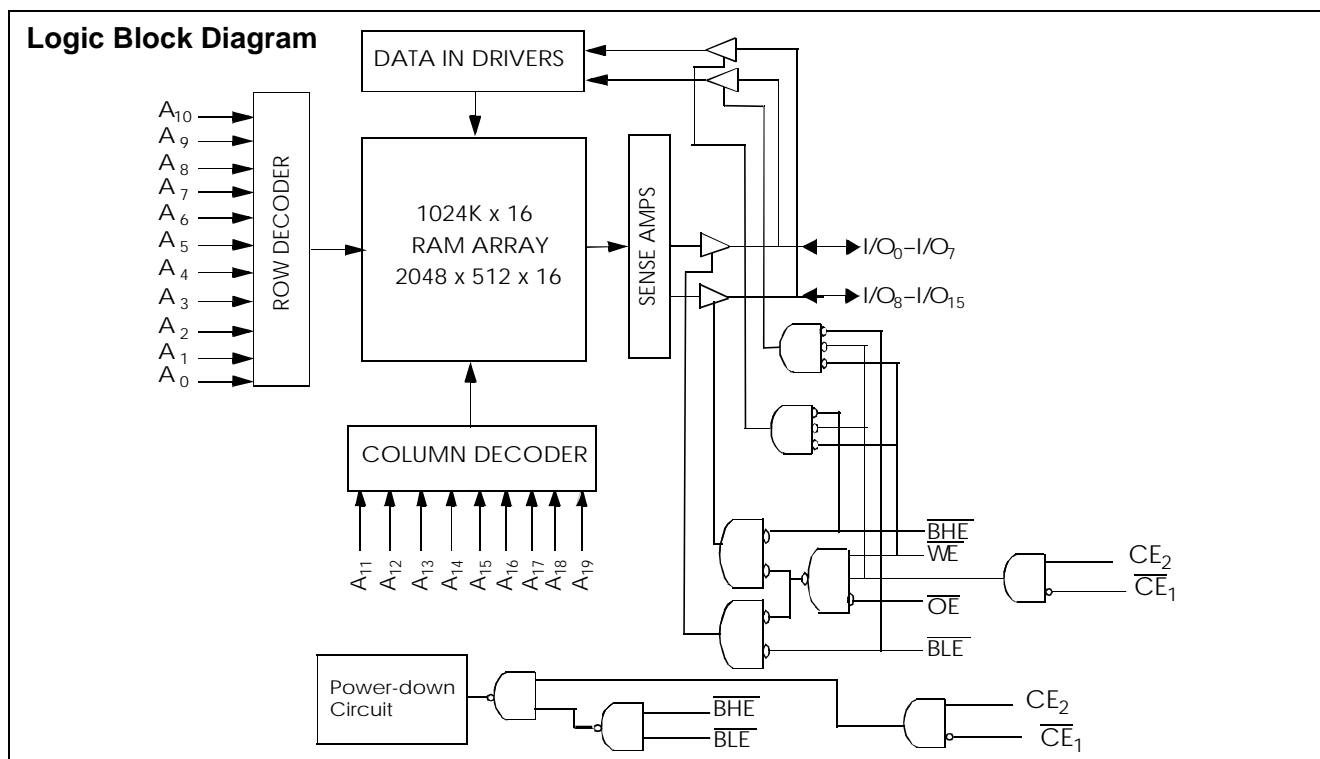

Note:

1. For best practice recommendations, please refer to the Cypress application note "System Design Guidelines" on <http://www.cypress.com>.



Pin Configuration^[2]

FPGA
Top View

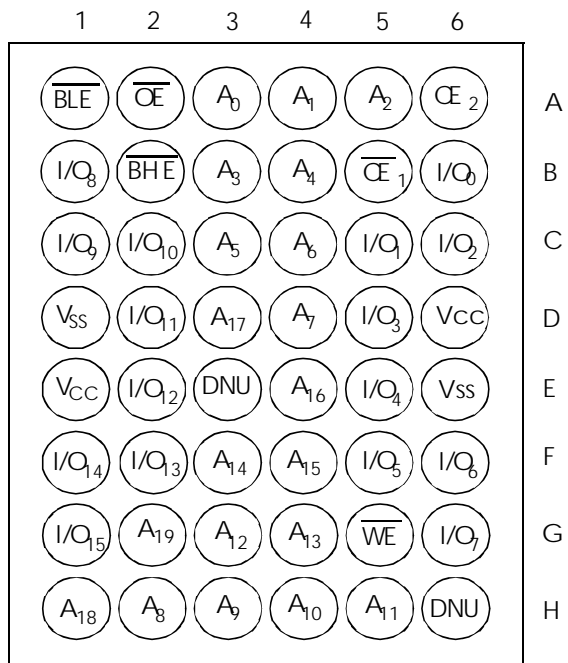

DataSheet4U.com

Note:

- 2. DNU pins are to be connected to V_{SS} or left open.

et4U.com

DataShee



PRELIMINARY

CY62167DV18
MoBL2™**Maximum Ratings**

(Above which the useful life may be impaired. For user guidelines, not tested.)

Storage Temperature -65°C to +150°C

Ambient Temperature with
Power Applied..... -55°C to +125°CSupply Voltage to Ground
Potential -0.2V to $V_{CCMAX} + 0.2V$ DC Voltage Applied to Outputs
in High-Z State^[3] -0.2V to $V_{CC} + 0.2V$ DC Input Voltage^[3] -0.2V to $V_{CC} + 0.2V$

Output Current into Outputs (LOW)..... 20 mA

Static Discharge Voltage..... > 2001V
(per MIL-STD-883, Method 3015)

Latch-up Current..... > 200 mA

Operating Range

Range	Ambient Temperature (T _A)	V _{CC} ^[4]
Industrial	-40°C to +85°C	1.65V to 1.95V

Product Portfolio

Product	V _{CC} Range(V)			Speed (ns)	Power Dissipation					
					Operating, I _{CC} (mA)				Standby, I _{SB2} (μA)	
	Min.	Typ.	Max.		f = 1 MHz		f = f _{MAX}			
					Typ.	Max.	Typ.	Max.	Typ.	Max.
CY62167DV18L	1.65	1.8	1.95	55	1.5	5	15	30	2.5	30
				70			12	25		
CY62167DV18LL	1.65	1.8	1.95	55	1.5	5	15	30	2.5	20
				70			12	25		

DC Electrical Characteristics (over the operating range)

Parameter	Description	Test Conditions	CY62167DV18-55			CY62167DV18-70			Unit	
			Min.	Typ.	Max.	Min.	Typ.	Max.		
V _{OH}	Output HIGH Voltage	I _{OH} = -0.1 mA, V _{CC} = 1.65V	1.4			1.4			V	
V _{OL}	Output LOW Voltage	I _{OL} = 0.1 mA, V _{CC} = 1.65V			0.2			0.2	V	
V _{IH}	Input HIGH Voltage		1.4		V _{CC} + 0.2	1.4		V _{CC} + 0.2	V	
V _{IL}	Input LOW Voltage		-0.2		0.4	-0.2		0.4	V	
I _{IX}	Input Leakage Current	GND ≤ V _I ≤ V _{CC}	-1		+1	-1		+1	μA	
I _{OZ}	Output Leakage Current	GND ≤ V _O ≤ V _{CC} , Output Disabled	-1		+1	-1		+1	μA	
I _{CC}	V _{CC} Operating Supply Current	f = f _{MAX} = 1/t _{RC} , V _{CC} = 1.95V, I _{OUT} = 0mA, CMOS level		15	30		12	25	mA	
		f = 1 MHz		1.5	5		1.5	5		
I _{SB1}	Automatic CE Power-down Current - CMOS Inputs	CE ₁ ≥ V _{CC} - 0.2V, CE ₂ ≤ 0.2V, V _{IN} ≥ V _{CC} - 0.2V, V _{IN} ≤ 0.2V, f = f _{MAX} (Address and Data Only), f = 0 (OE, WE, BHE and BLE)	L		2.5	30		2.5	30	μA
			LL		2.5	20		2.5	20	
I _{SB2}	Automatic CE Power-down Current - CMOS Inputs	CE ₁ ≥ V _{CC} - 0.2V, CE ₂ ≤ 0.2V, V _{IN} ≥ V _{CC} - 0.2V or V _{IN} ≤ 0.2V, f = 0, V _{CC} = 1.95V	L		2.5	30		2.5	30	μA
			LL		2.5	20		2.5	20	

Capacitance^[5]

Parameter	Description	Test Conditions	Max.	Unit
C _{IN}	Input Capacitance	TA = 25°C, f = 1 MHz	6	pF
C _{OUT}	Output Capacitance	V _{CC} = V _{CC(typ)}	8	pF



PRELIMINARY

CY62167DV18
MoBL2™Capacitance^[5]

Parameter	Description	Test Conditions	Max.	Unit
-----------	-------------	-----------------	------	------

Notes:

- $V_{IL(min.)} = -2.0V$ for pulse durations less than 20 ns.
- Typical values are included for reference only and are not guaranteed or tested. Typical values are measured at $V_{CC} = V_{CC(typ)}$, $T_A = 25^\circ C$.
- Tested initially and after any design or process changes that may affect these parameters.

Thermal Resistance

Parameter	Description	Test Conditions	BGA	Unit
θ_{JA}	Thermal Resistance (Junction to Ambient) ^[5]	Still Air, soldered on a 3 x 4.5 inch, two-layer printed circuit board	55	C/W
θ_{JC}	Thermal Resistance (Junction to Case) ^[5]		16	C/W

AC Test Loads and Waveforms

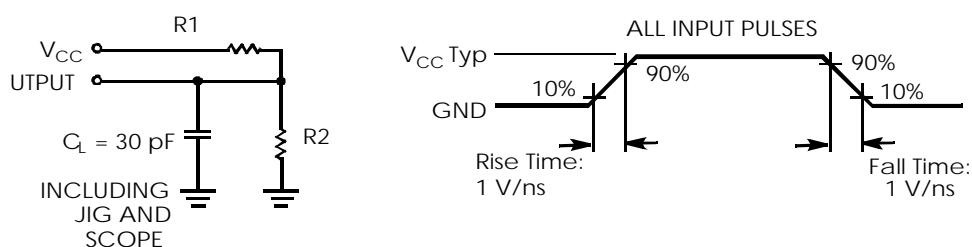

Equivalent to: THÉVENIN EQUIVALENT

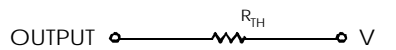

Parameters	1.8V	UNIT
R 1	13500	Ω
R 2	10800	Ω
R_{TH}	6000	Ω
V_{TH}	0.80	V

Data Retention Characteristics

Parameter	Description	Conditions	Min.	Typ.	Max.	Unit
V_{DR}	V_{CC} for Data Retention		1.0		1.95	V
I_{CCDR}	Data Retention Current	$V_{CC}=1.0V$, $CE_1 \geq V_{CC} - 0.2V$, $CE_2 \leq 0.2V$, $V_{IN} \geq V_{CC} - 0.2V$ or $V_{IN} \leq 0.2V$	L		15	μA
			LL		10	
$t_{CDR}^{[5]}$	Chip Deselect to Data Retention Time		0			ns
$t_R^{[6]}$	Operation Recovery Time		t_{RC}			ns



PRELIMINARY

CY62167DV18

MoBL2™

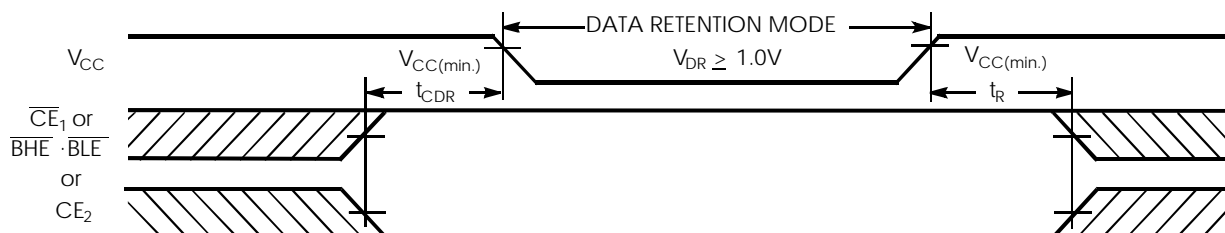
Data Retention Waveform^[7]

Notes:

6. Full device operation requires linear V_{CC} ramp from V_{DR} to $V_{CC(min.)} > 100 \mu s$ or stable at $V_{CC(min.)} > 100 \mu s$.
7. $\overline{BHE} \cdot \overline{BLE}$ is the AND of both \overline{BHE} and \overline{BLE} . Chip can be deselected by either disabling the chip enable signals or by disabling both \overline{BHE} and \overline{BLE} .

Switching Characteristics (over the operating range)^[8]

Parameter	Description	CY62167DV18-55		CY62167DV18-70		Unit
		Min.	Max.	Min.	Max.	
Read Cycle						
t_{RC}	Read Cycle Time	55		70		ns
t_{AA}	Address to Data Valid		55		70	ns
t_{OHA}	Data Hold from Address Change	10		10		ns
t_{ACE}	CE_1 LOW or CE_2 HIGH to Data Valid		55		70	ns
t_{DOE}	OE LOW to Data Valid		25		35	ns
t_{LZOE}	OE LOW to Low $Z^{[9]}$	5		5		ns
t_{HZOE}	OE HIGH to High $Z^{[9, 11]}$		20		25	ns
t_{LZCE}	CE_1 LOW or CE_2 HIGH to Low $Z^{[9]}$	10		10		ns
t_{HZCE}	CE_1 HIGH or CE_2 LOW to High $Z^{[9, 11]}$		20		25	ns
t_{PU}	CE_1 LOW or CE_2 HIGH to Power-up	0		0		ns
t_{PD}	CE_1 HIGH or CE_2 LOW to Power-down		55		70	ns
t_{DBE}	$\overline{BLE}/\overline{BHE}$ LOW to Data Valid		55		70	ns
$t_{LZBE}^{[10]}$	$\overline{BLE}/\overline{BHE}$ LOW to Low $Z^{[9]}$	5		5		ns
t_{HZBE}	$\overline{BLE}/\overline{BHE}$ HIGH to High- $Z^{[9, 11]}$		20		25	ns
Write Cycle^[12]						
t_{WC}	Write Cycle Time	55		70		ns
t_{SCE}	CE_1 LOW or CE_2 HIGH to Write End	40		60		ns
t_{AW}	Address Set-up to Write End	40		60		ns
t_{HA}	Address Hold from Write End	0		0		ns
t_{SA}	Address Set-up to Write Start	0		0		ns
t_{PWE}	\overline{WE} Pulse Width	40		45		ns
t_{BW}	$\overline{BLE}/\overline{BHE}$ LOW to Write End	45		60		ns
t_{SD}	Data Set-up to Write End	25		30		ns
t_{HD}	Data Hold from Write End	0		0		ns
t_{HZWE}	\overline{WE} LOW to High $Z^{[9, 11]}$		20		25	ns
t_{LZWE}	\overline{WE} HIGH to Low $Z^{[9]}$	10		10		ns



PRELIMINARY

CY62167DV18

MoBL2™

Switching Waveforms

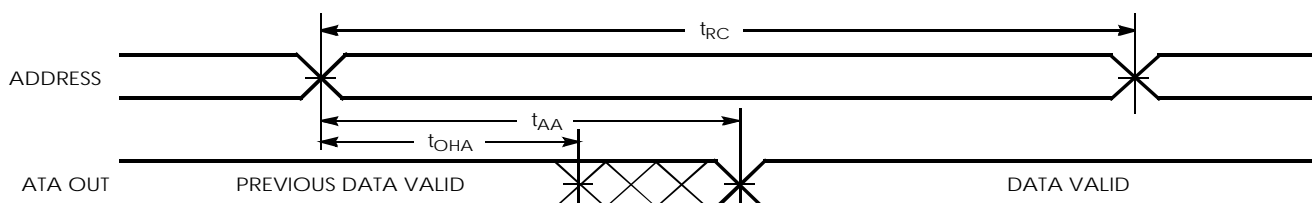
Read Cycle No. 1 (Address Transition Controlled)^[13, 14]

Notes:

8. Test conditions assume signal transition time of 3 ns or less, timing reference levels of $V_{CC(typ.)}/2$, input pulse levels of 0 to $V_{CC(typ.)}$, and output loading of the specified I_{OL} .
9. At any given temperature and voltage condition, t_{HZCE} is less than t_{LZCE} , t_{HZBE} is less than t_{LZBE} , t_{HZOE} is less than t_{LZOE} , and t_{HZWE} is less than t_{LZWE} for any given device.
10. If both byte enables are toggled together, this value is 10 ns.
11. t_{HZOE} , t_{HZCE} , t_{HZBE} , and t_{HZWE} transitions are measured when the outputs enter a high-impedance state.
12. The internal Write time of the memory is defined by the overlap of WE , $CE_1 = V_{IL}$, BHE and/or $BLE = V_{IL}$.
13. Device is continuously selected. OE , $CE_1 = V_{IL}$, BHE and/or $BLE = V_{IL}$, $CE_2 < Def >$
14. WE is HIGH for Read cycle.

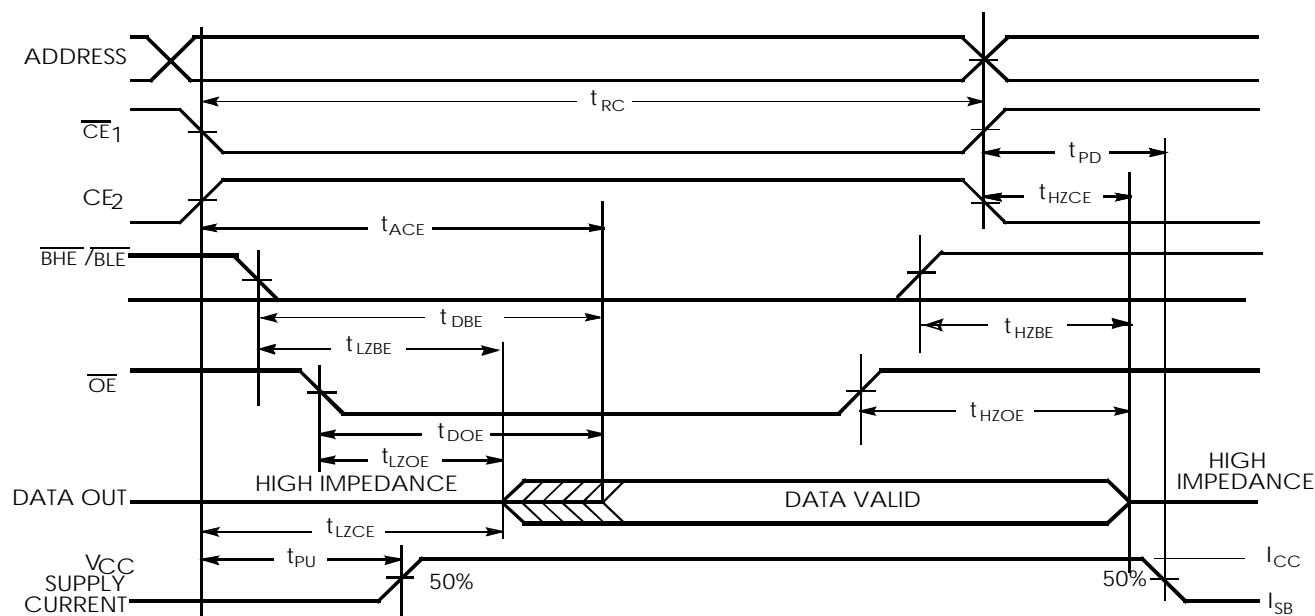
Read Cycle No. 2 (\overline{OE} Controlled)^[14, 15]

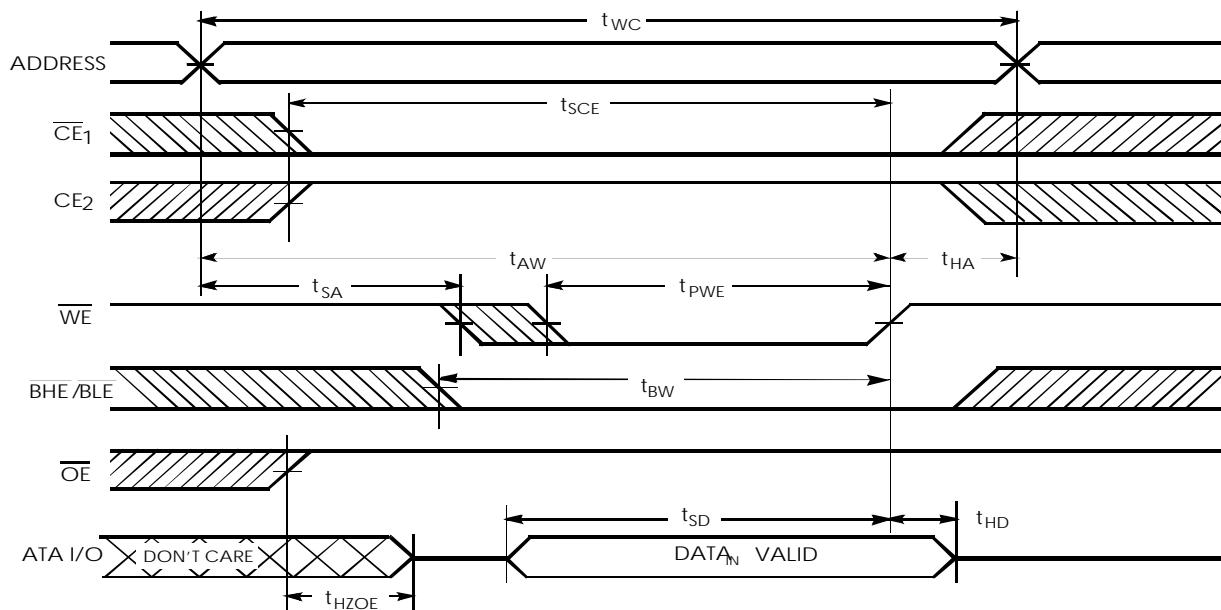

Switching Waveforms (continued)

Write Cycle No. 1 (WE Controlled)^[12, 16, 17, 18]

Note:

15. Address valid prior to or coincident with \overline{CE}_1 , \overline{BHE} , \overline{BLE} transition LOW and CE_2 transition HIGH.

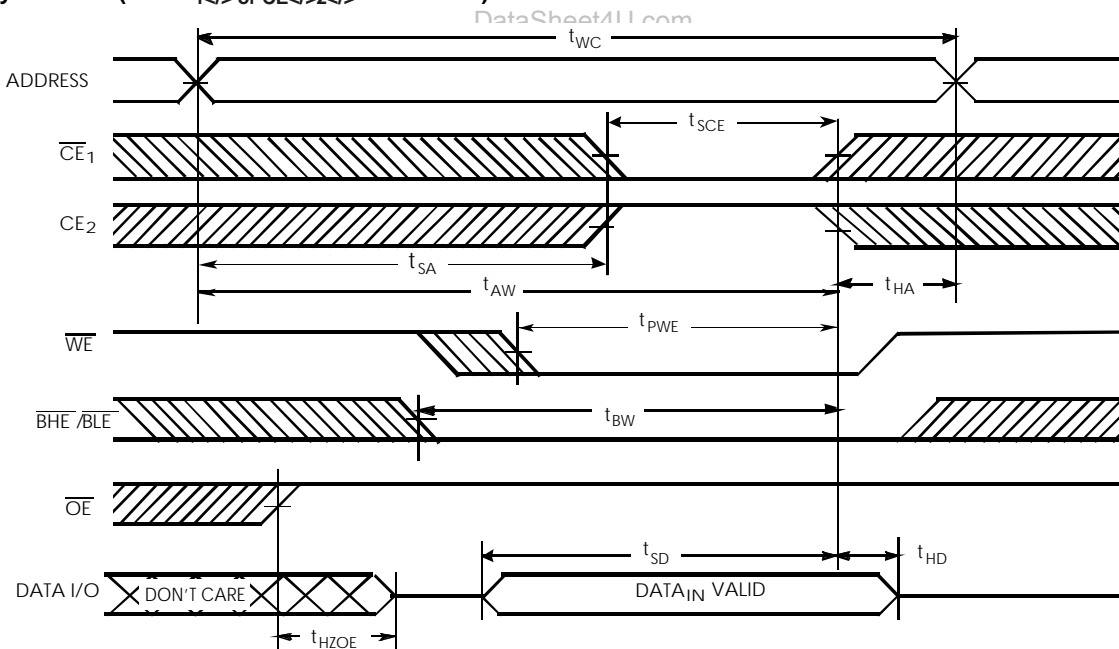
Write Cycle No. 2 ($\overline{CE}_{1/2}$ or $CE_{1/2}$ Controlled)^[12, 16, 17, 18]

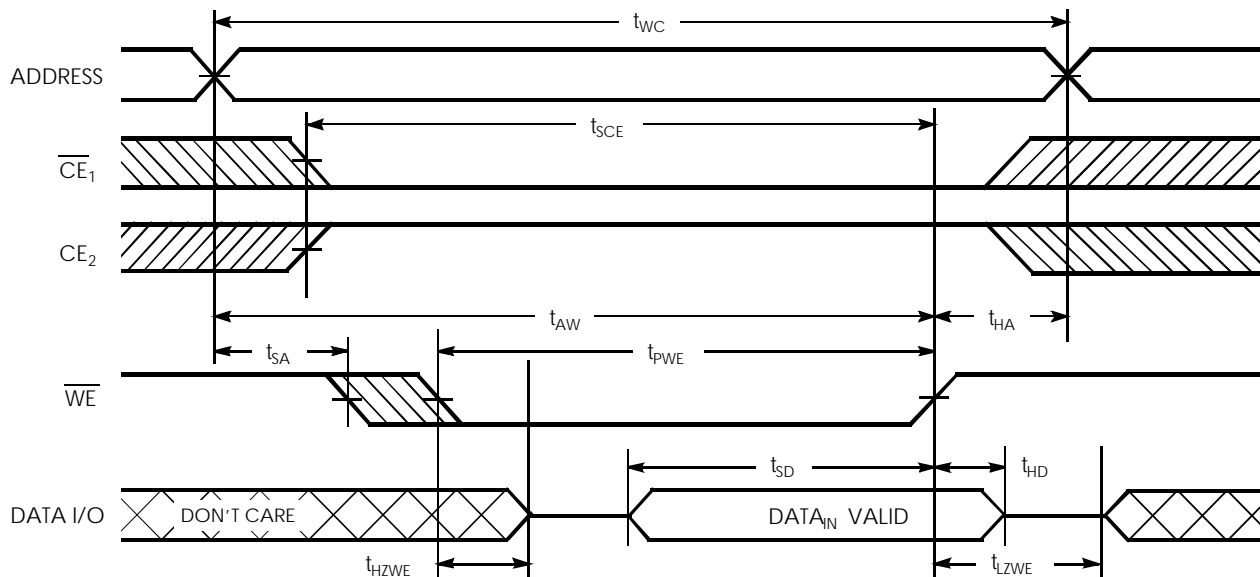
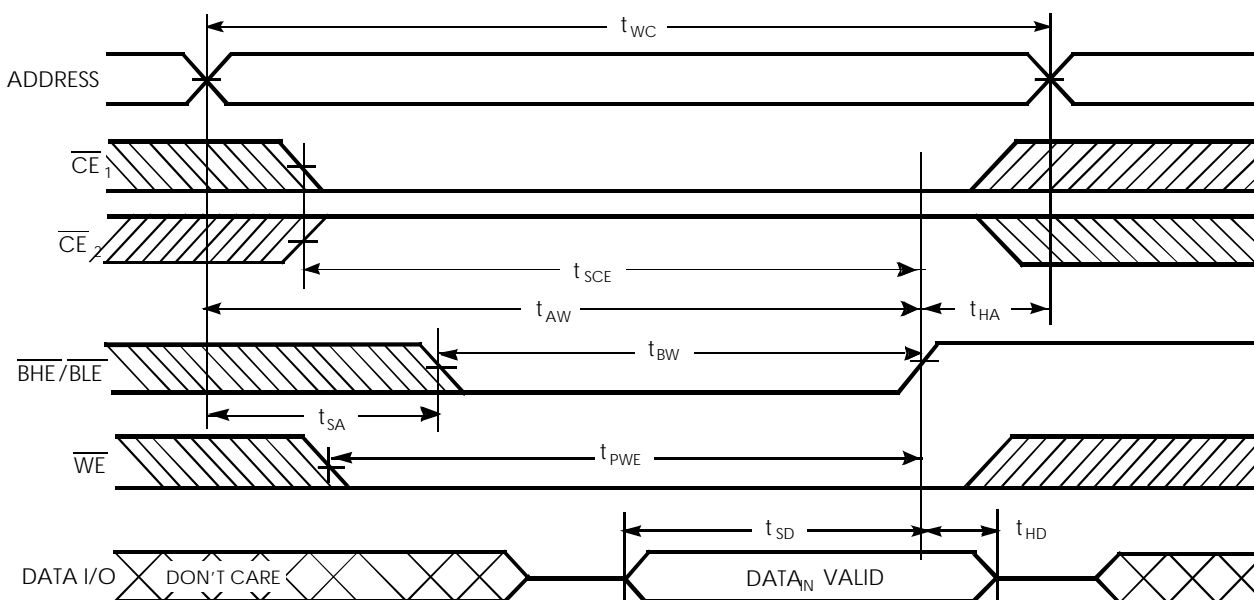

Switching Waveforms (continued)

Write Cycle No. 3 (\overline{WE} Controlled, \overline{OE} LOW)^[17, 18]Write Cycle No. 4 ($\overline{BHE}/\overline{BLE}$ Controlled, \overline{OE} LOW)^[17]

Notes:

16. Data I/O is high-impedance if $\overline{OE} = V_{IH}$.
17. If \overline{CE}_1 goes HIGH or \overline{CE}_2 goes LOW simultaneously with \overline{WE} HIGH, the output remains in a high-impedance state.
18. During the DON'T CARE period in the DATA I/O waveform, the I/Os are in output state and input signals should not be applied.



PRELIMINARY

CY62167DV18

MoBL2™

Truth Table

CE ₁	CE ₂	WE	OE	BHE	BLE	Input / Outputs	Mode	Power
H	X	X	X	X	X	High Z	Deselect/Power-down	Standby(I _{SB})
X	L	X	X	X	X	High Z	Deselect/Power-down	Standby(I _{SB})
X	X	X	X	H	H	High Z	Deselect/Power-down	Standby(I _{SB})
L	H	H	L	L	L	Data Out(I/O0- I/O15)	Read	Active(I _{CC})
L	H	H	L	H	L	Data Out(I/O0- I/O7); High Z (I/O8- I/O15)	Read	Active(I _{CC})
L	H	H	L	L	H	High Z (I/O0- I/O7); Data Out(I/O8- I/O15)	Read	Active(I _{CC})
L	H	H	H	L	H	High Z	Output Disabled	Active(I _{CC})
L	H	H	H	H	L	High Z	Output Disabled	Active(I _{CC})
L	H	H	H	L	L	High Z	Output Disabled	Active(I _{CC})
L	H	L	X	L	L	Data In (I/O0- I/O15)	Write	Active(I _{CC})
L	H	L	X	H	L	Data In (I/O0- I/O7); High Z (I/O8- I/O15)	Write	Active(I _{CC})
L	H	L	X	L	H	High Z (I/O0- I/O7); Data In (I/O8- I/O15)	Write	Active(I _{CC})



PRELIMINARY

CY62167DV18

MoBL2™

Ordering Information

Speed (ns)	Ordering Code	Package Name	Package Type	Operating Range
55	CY62167DV18L-55**I	TBD	48-ball Fine Pitch BGA (8.0 x 9.5 x 1.0 mm)	Industrial
	CY62167DV18LL-55**I	TBD	48-ball Fine Pitch BGA (8.0 x 9.5 x 1.0 mm)	
70	CY62167DV18L-70**I	TBD	48-ball Fine Pitch BGA (8.0 x 9.5 x 1.0 mm)	Industrial
	CY62167DV18LL-70**I	TBD	48-ball Fine Pitch BGA (8.0 x 9.5 x 1.0 mm)	

Package Diagram

48-lead VFBGA (8 x 9.5 x 1 mm) BV48B

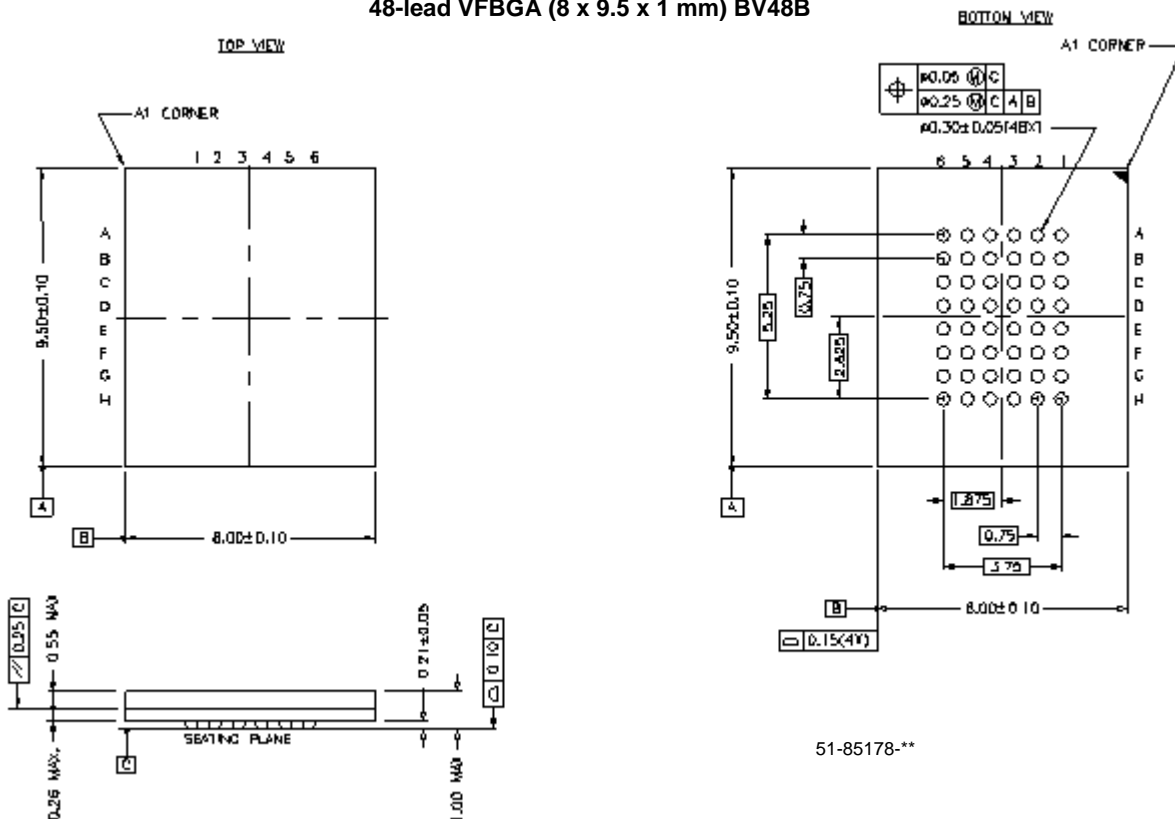

MoBL is a registered trademark, and MoBL2 and More Battery Life are trademarks of Cypress Semiconductor. All product and company names mentioned in this document are the trademarks of their respective holders.

**PRELIMINARY****CY62167DV18
MoBL2™****Document History Page**

Document Title: CY62167DV18MoBL2™ 16M (1024K x 16) Static RAM				
Document Number: 38-05326				
REV.	ECN NO.	Issue Date	Orig. of Change	Description of Change
**	118406	09/30/02	GUG	New Data Sheet
*A	123690	02/11/03	DPM	Changed Advance to Preliminary Added package diagram