



# 3.3V 64K x 18 Synchronous QuadPort™ Static RAM

## Features

- True four-ported memory cells which allow simultaneous access of the same memory location
- Synchronous Pipelined device
  - 64K x 18 organization
- Pipelined output mode allows fast 133-MHz operation
- High Bandwidth up to 10 Gbps (133 MHz x 18 bits wide x 4 ports)
- 0.25-micron CMOS for optimum speed/power
- High-speed clock to data access 4.7 ns (max.)
- 3.3V Low operating power
  - Active = 750 mA (maximum)
  - Standby = 5 mA (maximum)
- Counter wrap-around control
  - Internal mask register controls counter wrap-around
  - Counter-Interrupt flags to indicate wrap-around
- Counter readback on address lines
- Mask register readback on address lines
- Interrupt flags for message passing
- Master reset for all ports
- Width and depth expansion capabilities
- Dual Chip Enables on all ports for easy depth expansion
- Separate upper-byte and lower-byte controls on all ports
- 272-BGA package (27 mm x 27 mm 1.27-mm ball pitch)
- Commercial and Industrial temperature ranges
- IEEE 1149.1 JTAG boundary scan

## Top Level Logic Block Diagram

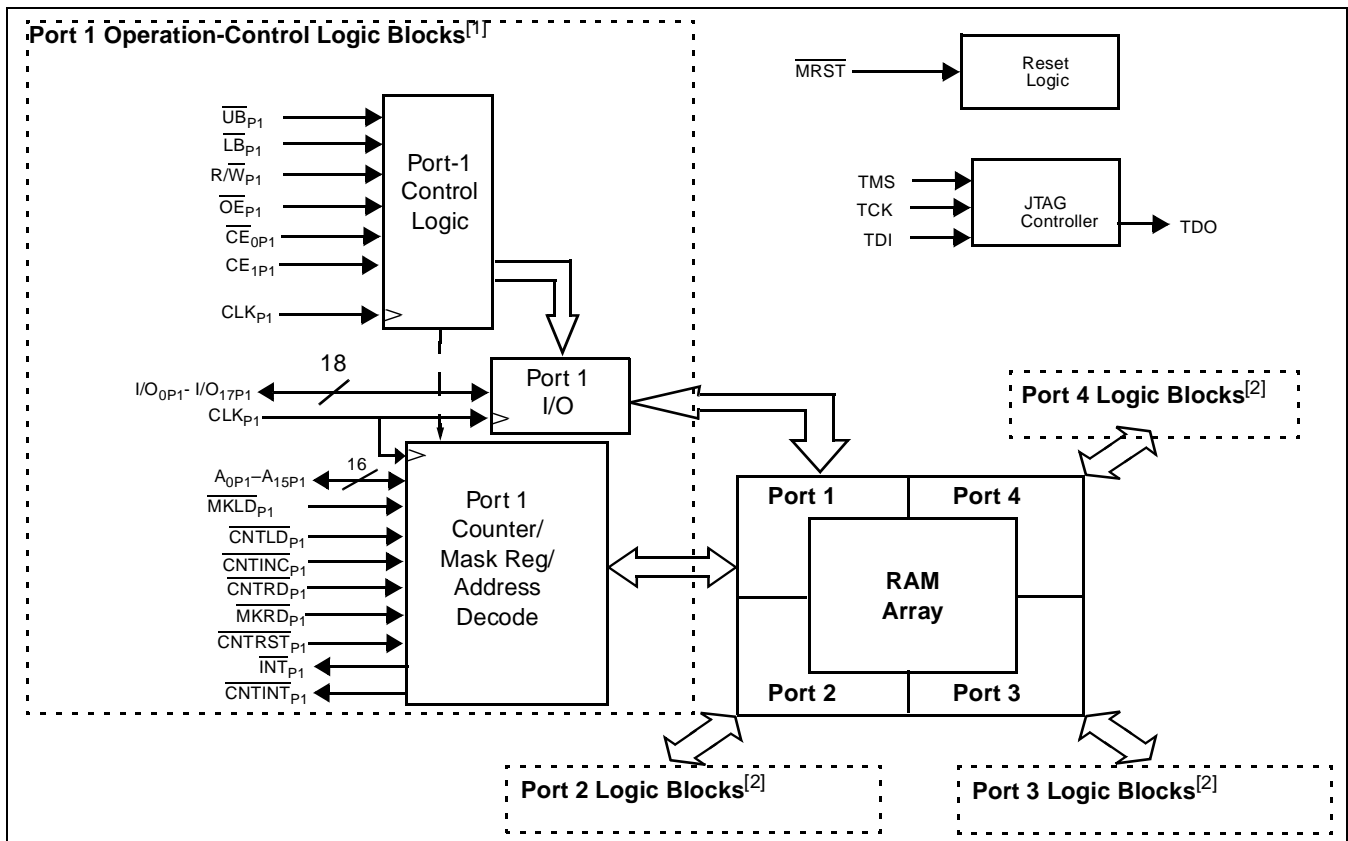

### Notes:

1. Port 1 Control Logic Block is detailed on page 2.
2. Port 2, Port 3, and Port 4 Logic Blocks are similar to Port 1 Logic Blocks.

For the most recent information, visit the Cypress web site at [www.cypress.com](http://www.cypress.com)

**Port 1 Operation-Control Logic Block Diagram:**

(Address Readback is independent of CEs)

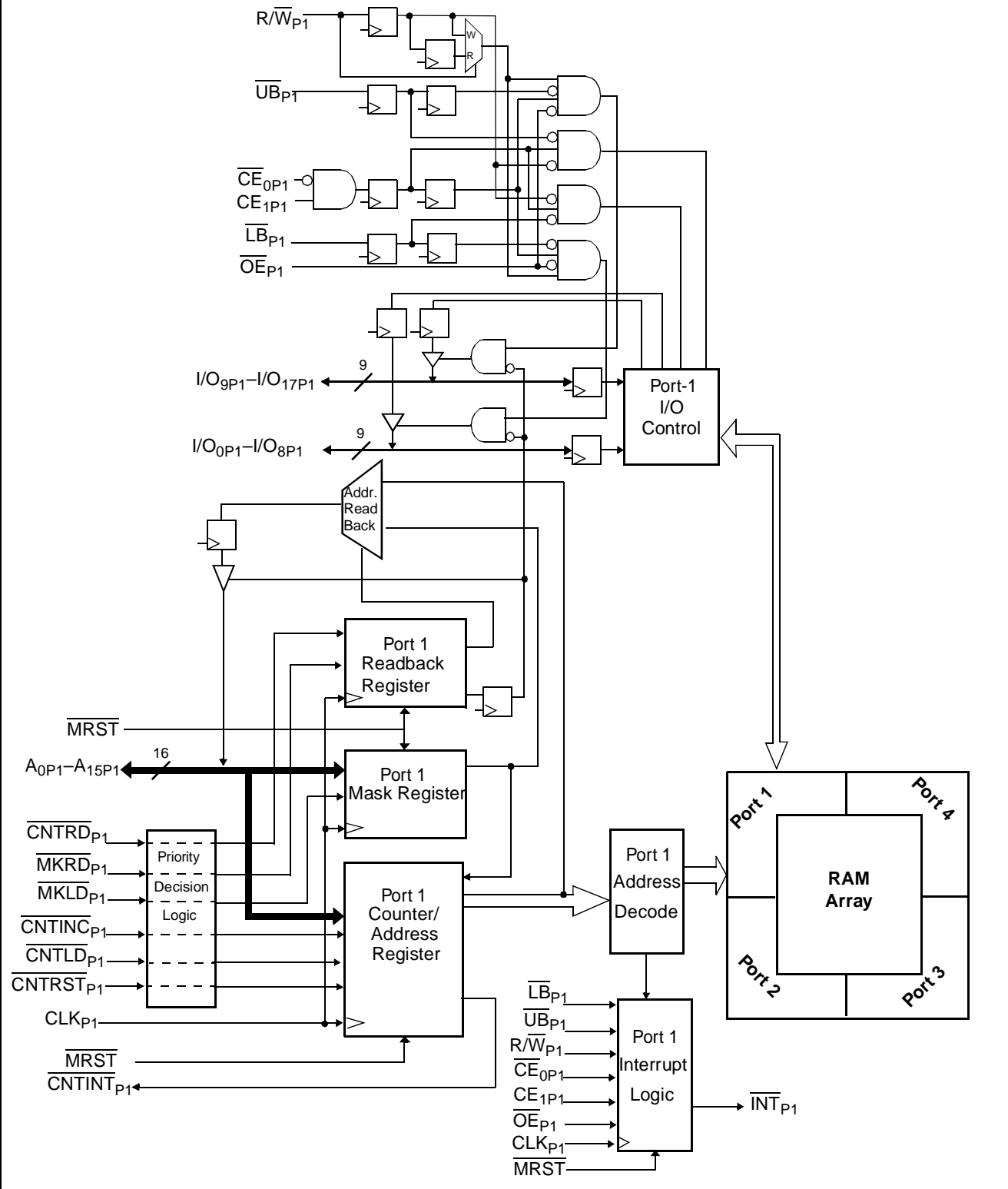

## Functional Description

The CY7C0430V is a 1-Mb synchronous true four-port Static RAM. This is a high-speed, low-power 3.3V CMOS four-port static RAM. Four ports are provided, permitting independent, simultaneous access for reads from any location in memory. A particular port can write to a certain location while other ports are reading that location simultaneously. The result of writing to the same location by more than one port at the same time is undefined. Registers on control, address and data lines allow for minimal set-up and hold time.

Data is registered for decreased cycle time. Clock to data valid  $t_{CD2} = 4.7$  ns. Each port contains a burst counter on the input address register. After externally loading the counter with the initial address the counter will self-increment the address internally (more details to follow). The internal write pulse width is independent of the duration of the R/W input signal. The internal write pulse is self-timed to allow the shortest possible cycle times.

A HIGH on  $\overline{CE}_0$  or LOW on  $CE_1$  for one clock cycle will power down the internal circuitry to reduce the static power consumption. One cycle is required with chip enables asserted to reactivate the outputs.

Counter enable inputs are provided to stall the operation of the address input and utilize the internal address generated by the

internal counter for fast interleaved memory applications. A port's burst counter is loaded with an external address when the port's Counter Load pin ( $\overline{CNTLD}$ ) is asserted LOW. When the port's Counter Increment pin ( $\overline{CNTINC}$ ) is asserted, the address counter will increment on each subsequent LOW-to-HIGH transition of that port's clock signal. This will read/write one word from/into each successive address location until  $\overline{CNTINC}$  is deasserted. The counter can address the entire memory array and will loop back to the start. Counter Reset ( $\overline{CNRST}$ ) is used to reset the burst counter. A counter-mask register is used to control the counter wrap. The counter and mask register operations are described in more details in the following sections.

The counter or mask register values can be read back on the bidirectional address lines by activating  $\overline{MKRD}$  or  $\overline{CNTRD}$  respectively.

The new features added to the QuadPort™ as compared to standard synchronous dual-ports include: readback of burst-counter internal address value on address lines, counter-mask registers to control the counter wrap-around, readback of mask register value on address lines, interrupt flags for message passing, JTAG for boundary scan, and asynchronous Master Reset.

**Pin Configuration**
**272-Ball Grid Array (BGA)**
**Top View**

	1	2	3	4	5	6	7	8	9	10	11	12	13	14	15	16	17	18	19	20				
A	$\overline{LB}$ P1	I/O17 P2	I/O15 P2	I/O13 P2	I/O11 P2	I/O9 P2	I/O16 P1	I/O14 P1	I/O12 P1	I/O10 P1	I/O10 P4	I/O12 P4	I/O14 P4	I/O16 P4	I/O9 P3	I/O11 P3	I/O13 P3	I/O15 P3	I/O17 P3	$\overline{LB}$ P4				
B	VDD1	$\overline{UB}$ P1	I/O16 P2	I/O14 P2	I/O12 P2	I/O10 P2	I/O17 P1	I/O13 P1	I/O11 P1	TMS	TDI	I/O11 P4	I/O13 P4	I/O17 P4	I/O10 P3	I/O12 P3	I/O14 P3	I/O16 P3	$\overline{UB}$ P4	VDD1				
C	A14 P1	A15 P1	CE1 P1	$\overline{CE0}$ P1	R/W P1	I/O15 P1	VSS2	VSS2	I/O9 P1	TCK	TDO	I/O9 P4	VSS2	VSS2	I/O15 P4	R/W P4	$\overline{CE0}$ P4	CE1 P4	A15 P4	A14 P4				
D	VSS1	A12 P1	A13 P1	$\overline{OE}$ P1	VDD2	VSS2	VSS2	VDD2	VDD	VSS	VSS	VDD	VDD2	VSS2	VSS2	VDD2	$\overline{OE}$ P4	A13 P4	A12 P4	VSS1				
E	A10 P1	A11 P1	MKRD P1	CNTRD P1													CNTRD P4	MKRD P4	A11 P4	A10 P4				
F	A7 P1	A8 P1	A9 P1	CNTINT P1													CNTINT P4	A9 P4	A8 P4	A7 P4				
G	VSS1	A5 P1	A6 P1	CNTINC P1													CNTINC P4	A6 P4	A5 P4	VSS1				
H	A3 P1	A4 P1	MKLD P1	CNTLD P1													CNTLD P4	MKLD P4	A4 P4	A3 P4				
J	VDD1	A1 P1	A2 P1	VDD	GND <sup>[3]</sup>																VDD	A2 P4	A1 P4	VDD1
K	A0 P1	INT P1	CNTRST P1	CLK P1	GND <sup>[3]</sup>																CLK P4	CNTRST P4	INT P4	A0 P4
L	A0 P2	INT P2	CNTRST P2	VSS	GND <sup>[3]</sup>																VSS	CNTRST P3	INT P3	A0 P3
M	VDD1	A1 P2	A2 P2	CLK P2	GND <sup>[3]</sup>																CLK P3	A2 P3	A1 P3	VDD1
N	A3 P2	A4 P2	MKLD P2	CNTLD P2													CNTLD P3	MKLD P3	A4 P3	A3 P3				
P	VSS1	A5 P2	A6 P2	CNTINC P2													CNTINC P3	A6 P3	A5 P3	VSS1				
R	A7 P2	A8 P2	A9 P2	CNTINT P2													CNTINT P3	A9 P3	A8 P3	A7 P3				
T	A10 P2	A11 P2	MKRD P2	CNTRD P2													CNTRD P3	MKRD P3	A11 P3	A10 P3				
U	VSS1	A12 P2	A13 P2	$\overline{OE}$ P2	VDD2	VSS2	VSS2	VDD2	VDD	VSS	VSS	VDD	VDD2	VSS2	VSS2	VDD2	$\overline{OE}$ P3	A13 P3	A12 P3	VSS1				
V	A14 P2	A15 P2	CE1 P2	$\overline{CE0}$ P2	R/W P2	I/O6 P2	VSS2	VSS2	I/O0 P2	NC	NC	I/O0 P3	VSS2	VSS2	I/O6 P3	R/W P3	$\overline{CE0}$ P3	CE1 P3	A15 P3	A14 P3				
W	VDD1	$\overline{UB}$ P2	I/O7 P1	I/O5 P1	I/O3 P1	I/O1 P1	I/O8 P2	I/O4 P2	I/O2 P2	MRST	VSS	I/O2 P3	I/O4 P3	I/O8 P3	I/O1 P4	I/O3 P4	I/O5 P4	I/O7 P4	$\overline{UB}$ P3	VDD1				
Y	$\overline{LB}$ P2	I/O8 P1	I/O6 P1	I/O4 P1	I/O2 P1	I/O0 P1	I/O7 P2	I/O5 P2	I/O3 P2	I/O1 P2	I/O1 P3	I/O3 P3	I/O5 P3	I/O7 P3	I/O0 P4	I/O2 P4	I/O4 P4	I/O6 P4	I/O8 P4	$\overline{LB}$ P3				

**Note:**

- Central Leads are for thermal dissipation only. They are connected to device  $V_{SS}$ .

**Selection Guide**

	<b>CY7C0430V -133</b>	<b>CY7C0430V -100</b>
$f_{MAX2}$ (MHz)	133	100
Max Access Time (ns) (Clock to Data)	4.7	5.0
Max Operating Current $I_{CC}$ (mA)	750	600
Max Standby Current for $I_{SB1}$ (mA) (All ports TTL Level)	200	150
Max Standby Current for $I_{SB3}$ (mA) (All ports CMOS Level)	5	5

**Pin Definitions**

<b>Port 1</b>	<b>Port 2</b>	<b>Port 3</b>	<b>Port 4</b>	<b>Description</b>
$A_{0P1}-A_{15P1}$	$A_{0P2}-A_{15P2}$	$A_{0P3}-A_{15P3}$	$A_{0P4}-A_{15P4}$	Address Input/Output.
$I/O_{0P1}-I/O_{17P1}$	$I/O_{0P2}-I/O_{17P2}$	$I/O_{0P3}-I/O_{17P3}$	$I/O_{0P4}-I/O_{17P4}$	Data Bus Input/Output.
$CLK_{P1}$	$CLK_{P2}$	$CLK_{P3}$	$CLK_{P4}$	Clock Input. This input can be free running or strobed. Maximum clock input rate is $f_{MAX}$ .
$LB_{P1}$	$LB_{P2}$	$LB_{P3}$	$LB_{P4}$	Lower Byte Select Input. Asserting this signal LOW enables read and write operations to the lower byte. For read operations both the LB and OE signals must be asserted to drive output data on the lower byte of the data pins.
$UB_{P1}$	$UB_{P2}$	$UB_{P3}$	$UB_{P4}$	Upper Byte Select Input. Same function as LB, but to the upper byte.
$CE_{0P1}, CE_{1P1}$	$CE_{0P2}, CE_{1P2}$	$CE_{0P3}, CE_{1P3}$	$CE_{0P4}, CE_{1P4}$	Chip Enable Input. To select any port, both $CE_0$ AND $CE_1$ must be asserted to their active states ( $CE_0 \leq V_{IL}$ and $CE_1 \geq V_{IH}$ ).
$OE_{P1}$	$OE_{P2}$	$OE_{P3}$	$OE_{P4}$	Output Enable Input. This signal must be asserted <u>LOW</u> to enable the I/O data lines during read operations. OE is asynchronous input.
$R/W_{P1}$	$R/W_{P2}$	$R/W_{P3}$	$R/W_{P4}$	Read/Write Enable Input. This signal is asserted LOW to write to the dual port memory array. For read operations, assert this pin HIGH.
<b>MRST</b>				Master Reset Input. This is one signal for All Ports. MRST is an asynchronous input. Asserting MRST LOW performs all of the reset functions as described in the text. A MRST operation is required at power-up.
$CNTRST_{P1}$	$CNTRST_{P2}$	$CNTRST_{P3}$	$CNTRST_{P4}$	Counter Reset Input. Asserting this signal LOW resets the burst address counter of its respective port to zero. CNTRST is second to MRST in priority with respect to counter and mask register operations.
$MKLD_{P1}$	$MKLD_{P2}$	$MKLD_{P3}$	$MKLD_{P4}$	Mask Register Load input. Asserting this signal LOW loads the mask register with the external address available on the address lines. MKLD operation has higher priority over CNTLD operation.
$CNTLD_{P1}$	$CNTLD_{P2}$	$CNTLD_{P3}$	$CNTLD_{P4}$	Counter Load Input. Asserting this signal LOW loads the burst counter with the external address present on the address pins.
$CNTINC_{P1}$	$CNTINC_{P2}$	$CNTINC_{P3}$	$CNTINC_{P4}$	Counter Increment Input. Asserting this signal LOW increments the burst address counter of its respective port on each rising edge of CLK.

**Pin Definitions** (continued)

Port 1	Port 2	Port 3	Port 4	Description
CNTRD <sub>P1</sub>	CNTRD <sub>P2</sub>	CNTRD <sub>P3</sub>	CNTRD <sub>P4</sub>	Counter Readback Input. When asserted LOW, the internal address value of the counter will be read back on the address lines. During CNTRD operation, both CNTLD and CNTINC must be HIGH. Counter readback operation has higher priority over mask register readback operation. Counter readback operation is independent of port chip enables. If address readback operation occurs with chip enables active ( $\overline{CE}_0 = \text{LOW}$ , $CE_1 = \text{HIGH}$ ), the data lines (I/Os) will be three-stated. The readback timing will be valid after one no-operation cycle plus $t_{CD2}$ from the rising edge of the next cycle.
MKRD <sub>P1</sub>	MKRD <sub>P2</sub>	MKRD <sub>P3</sub>	MKRD <sub>P4</sub>	Mask Register Readback Input. When asserted LOW, the value of the mask register will be readback on address lines. During mask register readback operation, all counter and MKLD inputs must be HIGH (see Counter and Mask Register Operations truth table). Mask register readback operation is independent of port chip enables. If address readback operation occurs with chip enables active ( $\overline{CE}_0 = \text{LOW}$ , $CE_1 = \text{HIGH}$ ), the data lines (I/Os) will be three-stated. The readback will be valid after one no-operation cycle plus $t_{CD2}$ from the rising edge of the next cycle.
CNTINT <sub>P1</sub>	CNTINT <sub>P2</sub>	CNTINT <sub>P3</sub>	CNTINT <sub>P4</sub>	Counter Interrupt flag output. Flag is asserted LOW for one clock cycle when the counter wraps around to location zero.
INT <sub>P1</sub>	INT <sub>P2</sub>	INT <sub>P3</sub>	INT <sub>P4</sub>	Interrupt flag output. Interrupt permits communications between all four ports. The upper four memory locations can be used for message passing. Example of operation: INT <sub>P4</sub> is asserted LOW when another port writes to the mailbox location of Port 4. Flag is cleared when Port 4 reads the contents of its mailbox. The same operation is applicable to Ports 1, 2, and 3.
TMS				JTAG Test Mode Select Input. It controls the advance of JTAG TAP state machine. State machine transitions occur on the rising edge of TCK.
TCK				JTAG Test Clock Input. This can be CLK of any port or an external clock connected to the JTAG TAP.
TDI				JTAG Test Data Input. This is the only data input. TDI inputs will shift data serially in to the selected register.
TDO				JTAG Test Data Output. This is the only data output. TDO transitions occur on the falling edge of TCK. TDO normally three-stated except when captured data is shifted out of the JTAG TAP.
GND				Thermal ground for heat dissipation.
V <sub>SS</sub>				Ground Input.
V <sub>DD</sub>				Power Input.
V <sub>SS1</sub>				Address lines ground Input.
V <sub>DD1</sub>				Address lines power Input.
V <sub>SS2</sub>				Data lines ground Input.
V <sub>DD2</sub>				Data lines power Input.



**Maximum Ratings**

(Above which the useful life may be impaired. For user guidelines, not tested.)

- Storage Temperature ..... -65°C to + 150°C
- Ambient Temperature with Power Applied .....-55°C to + 125°C
- Supply Voltage to Ground Potential ..... -0.5V to + 4.6V
- DC Voltage Applied to Outputs in High Z State.....-0.5V to  $V_{CC}+0.5V$

- DC Input Voltage .....-0.5V to  $V_{CC}+0.5V$
- Output Current into Outputs (LOW)..... 20 mA
- Static Discharge Voltage ..... >2001V
- Latch-Up Current ..... >200 mA

**Operating Range**

Range	Ambient Temperature	$V_{DD}$
Commercial	0°C to +70°C	3.3V ± 150 mV
Industrial	-40°C to +85°C	3.3V ± 150 mV

**Electrical Characteristics** Over the Operating Range

Parameter	Description	CY7C0430V						Unit
		-133			-100			
		Min.	Typ	Max	Min.	Typ	Max	
$V_{OH}$	Output HIGH Voltage ( $V_{CC} = \text{Min.}, I_{OH} = -4.0 \text{ mA}$ )	2.4			2.4			V
$V_{OL}$	Output LOW Voltage ( $V_{CC} = \text{Min.}, I_{OH} = +4.0 \text{ mA}$ )			0.4			0.4	V
$V_{IH}$	Input HIGH Voltage	2.0			2.0			V
$V_{IL}$	Input LOW Voltage			0.8			0.8	V
$I_{OZ}$	Output Leakage Current	-10		10	-10		10	μA
$I_{CC}$	Operating Current ( $V_{CC} = \text{Max.}, I_{OZ} = 0 \text{ mA}$ ) Outputs Disabled, $CE = V_{IL}, f = f_{max}$	Indust.	413	750		330	600	mA
		Com'l.						mA
$I_{SB1}$	Standby Current (4 Ports toggling at TTL Levels, 0 active) $CE_{1-4} \geq V_{IH}, f = f_{MAX}$	Indust.	80	200		60	150	mA
		Com'l.						mA
$I_{SB2}$	Standby Current (4 Ports toggling at TTL Levels, 1 active) $CE_1   CE_2   CE_3   CE_4 \leq V_{IL}, f = f_{MAX}$	Indust.	170	349		128	263	mA
		Com'l.						mA
$I_{SB3}$	Standby Current (4 Ports CMOS Level, 0 active) $CE_{1-4} \geq V_{IH}, f = 0$	Indust.	1.5	5		1.5	5	mA
		Com'l.						μA
$I_{SB4}$	Standby Current (4 Ports CMOS Level, 1 active and toggling) $CE_1   CE_2   CE_3   CE_4 \leq V_{IL}, f = f_{MAX}$	Indust.	110	240		83	180	mA
		Com'l.						mA

**JTAG TAP Electrical Characteristics** Over the Operating Range

Parameter	Description	Test Conditions	Min.	Max.	Unit
$V_{OH1}$	Output HIGH Voltage	$I_{OH} = -4.0 \text{ mA}$	2.4		V
$V_{OL1}$	Output LOW Voltage	$I_{OL} = 4.0 \text{ mA}$		0.4	V
$V_{IH}$	Input HIGH Voltage		2.0		V
$V_{IL}$	Input LOW Voltage			0.8	V
$I_X$	Input Leakage Current	$GND \leq V_I \leq V_{DD}$	-100	100	μA

**Capacitance**

Parameter	Description	Test Conditions	Max.	Unit
$C_{IN}$	Input Capacitance	$T_A = 25^\circ\text{C}, f = 1 \text{ MHz}, V_{CC} = 3.3\text{V}$	8	pF
$C_{OUT}$	Output Capacitance		8	pF

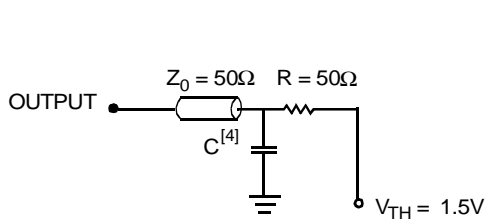
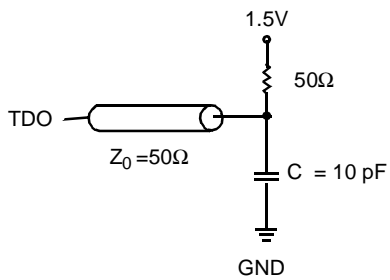
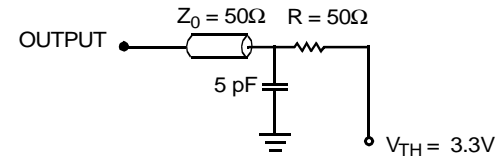
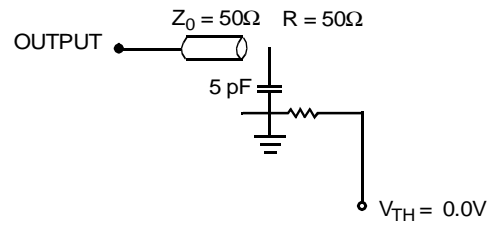
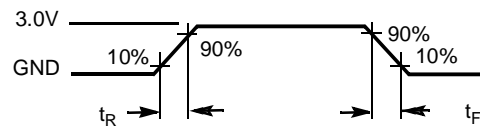
**AC Test Load**

**(a) Normal Load**

**(c) TAP Load**

**(b) Three-State Delay**

**ALL INPUT PULSES**
**Note:**

4. Test Conditions: C = 10 pF.



**Switching Characteristics** Over the Industrial Operating Range

Parameter	Description	CY7C0430V				Unit
		-133		-100		
		Min.	Max.	Min.	Max.	
$f_{MAX2}$	Maximum Frequency		133		100	MHz
$t_{CYC2}$	Clock Cycle Time	7.5		10		ns
$t_{CH2}$	Clock HIGH Time	3		4		ns
$t_{CL2}$	Clock LOW Time	3		4		ns
$t_R$	Clock Rise Time		2		3	ns
$t_F$	Clock Fall Time		2		3	ns
$t_{SA}$	Address Set-up Time	2.3		3		ns
$t_{HA}$	Address Hold Time	0.7		0.7		ns
$t_{SC}$	Chip Enable Set-up Time	2.3		3		ns
$t_{HC}$	Chip Enable Hold Time	0.7		0.7		ns
$t_{SW}$	R/W Set-up Time	2.3		3		ns
$t_{HW}$	R/W Hold Time	0.7		0.7		ns
$t_{SD}$	Input Data Set-up Time	2.3		3		ns
$t_{HD}$	Input Data Hold Time	0.7		0.7		ns
$t_{SB}$	Byte Set-up Time	2.3		3		ns
$t_{HB}$	Byte Hold Time	0.7		0.7		ns
$t_{SCLD}$	CNTLD Set-up Time	2.3		3		ns
$t_{HCLD}$	CNTLD Hold Time	0.7		0.7		ns
$t_{SCINC}$	CNTINC Set-up Time	2.3		3		ns
$t_{HCINC}$	CNTINC Hold Time	0.7		0.7		ns
$t_{SCRST}$	CNTRST Set-up Time	2.3		3		ns
$t_{HCRST}$	CNTRST Hold Time	0.7		0.7		ns
$t_{SCRD}$	CNTRD Set-up Time	2.3		3		ns
$t_{HCRD}$	CNTRD Hold Time	0.7		0.7		ns
$t_{SMLD}$	MKLD Set-up Time	2.3		3		ns
$t_{HMLD}$	MKLD Hold Time	0.7		0.7		ns
$t_{SMRD}$	MKRD Set-up Time	2.3		3		ns
$t_{HMRD}$	MKRD Hold Time	0.7		0.7		ns
$t_{OE}$	Output Enable to Data Valid		6.5		8	ns
$t_{OLZ}^{[5]}$	OE to LOW Z	1		1		ns
$t_{OHZ}^{[5]}$	OE to HIGH Z	1	6	1	7	ns
$t_{CD2}$	Clock to Data Valid		4.7		5	ns
$t_{CA2}$	Clock to Counter Address Readback Valid		4.7		5	ns
$t_{CM2}$	Clock to Mask Register readback Valid		4.7		5	ns
$t_{DC}$	Data Output Hold After Clock HIGH	1		1		ns
$t_{CKHZ}^{[6]}$	Clock HIGH to Output High Z	1	4.8	1	6.8	ns
$t_{CKLZ}^{[6]}$	Clock HIGH to Output LOW Z	1		1		ns
$t_{SINT}$	Clock to INT Set Time	1	7.5	1	10	ns
$t_{RINT}$	Clock to INT Reset Time	1	7.5	1	10	ns
$t_{SCINT}$	Clock to CNTINT Set Time	1	7.5	1	10	ns
$t_{RCINT}$	Clock to CNTINT Reset Time	1	7.5	1	10	ns

**Switching Characteristics** Over the Industrial Operating Range (continued)

Parameter	Description	CY7C0430V				Unit
		-133		-100		
		Min.	Max.	Min.	Max.	
<b>Master Reset Timing</b>						
$t_{RS}$	Master Reset Pulse Width	7.5		10		ns
$t_{RSR}$	Master Reset Recovery Time	7.5		10		ns
$t_{ROF}$	Master Reset to Output Flags Reset Time		6.5		8	ns
<b>Port to Port Delays</b>						
$t_{CCS}$	Clock to Clock Set-up Time	6.5		9		ns

**Notes:**

5. This parameter is guaranteed by design, but it is not production tested.
6. Valid for both address and data outputs.

**JTAG Timing and Switching Waveforms**

Parameter	Description	CY7C0430V				Unit
		-133		-100		
		Min.	Max.	Min.	Max.	
$f_{JTAG}$	Maximum JTAG TAP Controller Frequency		10		10	MHz
$t_{TCYC}$	TCK Clock Cycle Time	100		100		ns
$t_{TH}$	TCK Clock High Time	40		40		ns
$t_{TL}$	TCK Clock Low Time	40		40		ns
$t_{TMSS}$	TMS Setup to TCK Clock Rise	10		10		ns
$t_{TMSH}$	TMS Hold After TCK Clock Rise	10		10		ns
$t_{TDIS}$	TDI Setup to TCK Clock Rise	10		10		ns
$t_{TDIH}$	TDI Hold after TCK Clock Rise	10		10		ns
$t_{TDOV}$	TCK Clock Low to TDO Valid		20		20	ns
$t_{TDOX}$	TCK Clock Low to TDO Invalid	0		0		ns

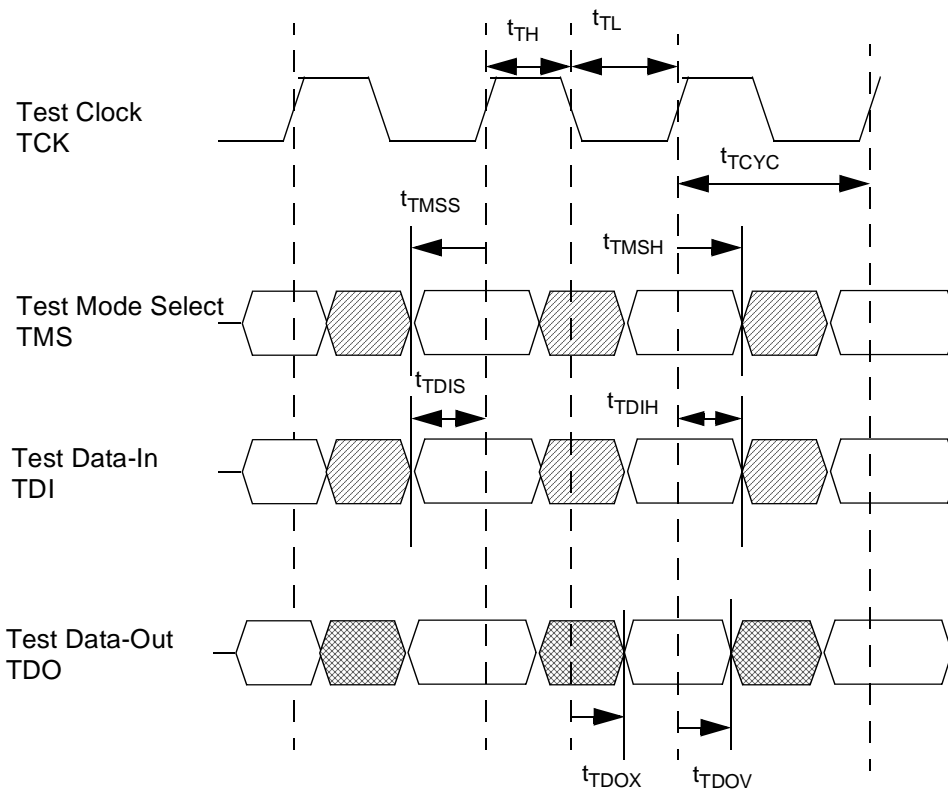

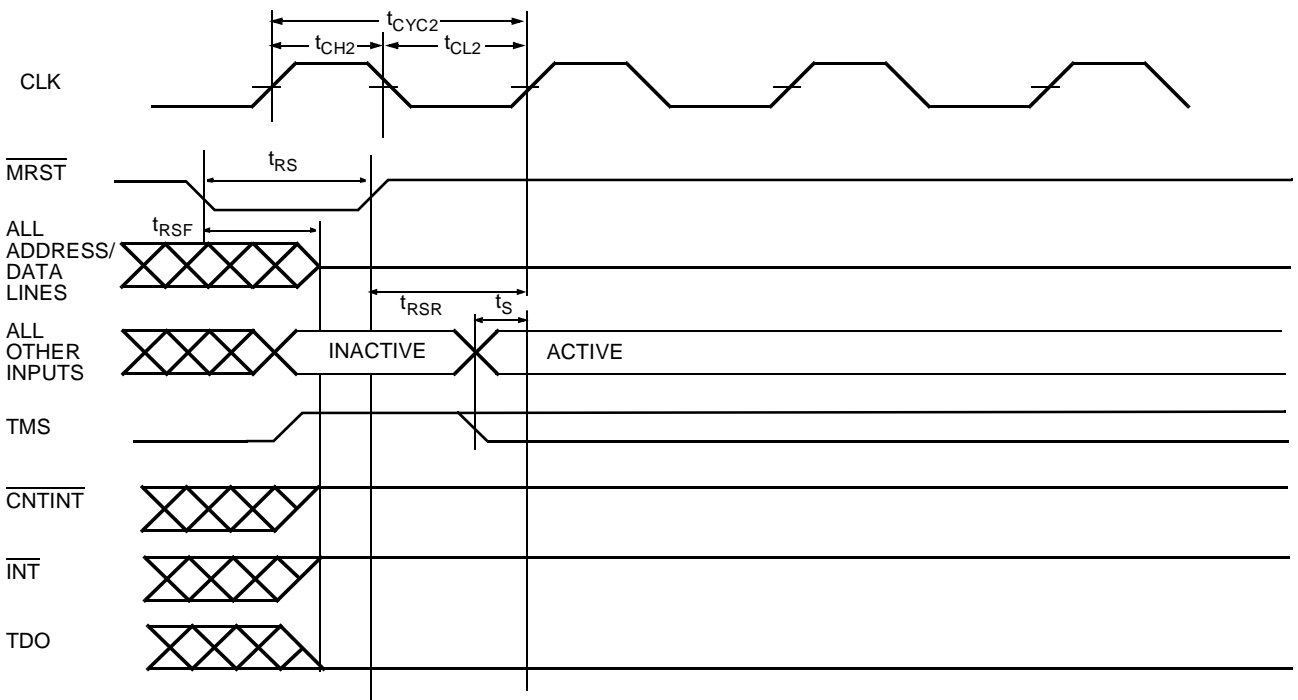
**Switching Waveforms**
**Master Reset<sup>[7]</sup>**

**Notes:**

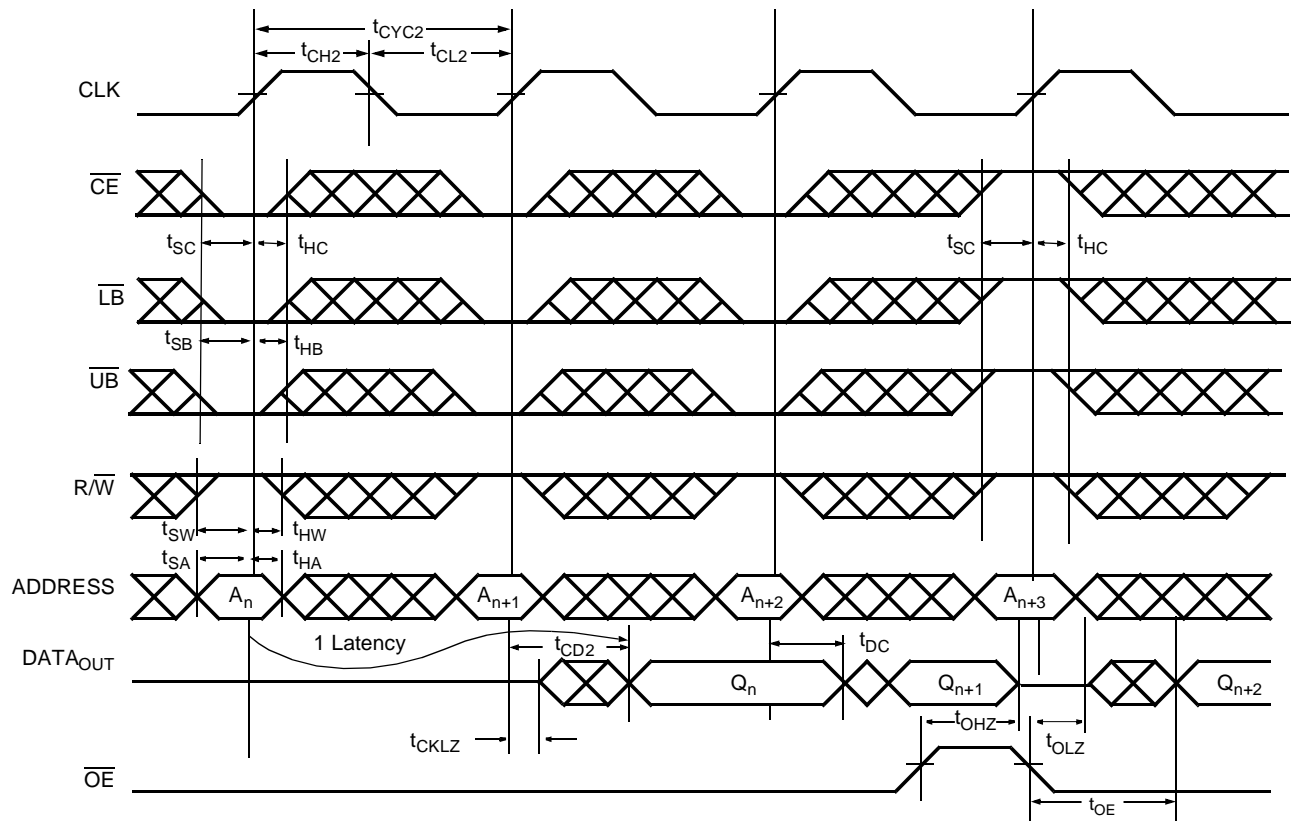
- $t_s$  is the set-up time required for all input control signals.

**Switching Waveforms (continued)**
**Read Cycle<sup>[8, 9, 10, 11, 12]</sup>**

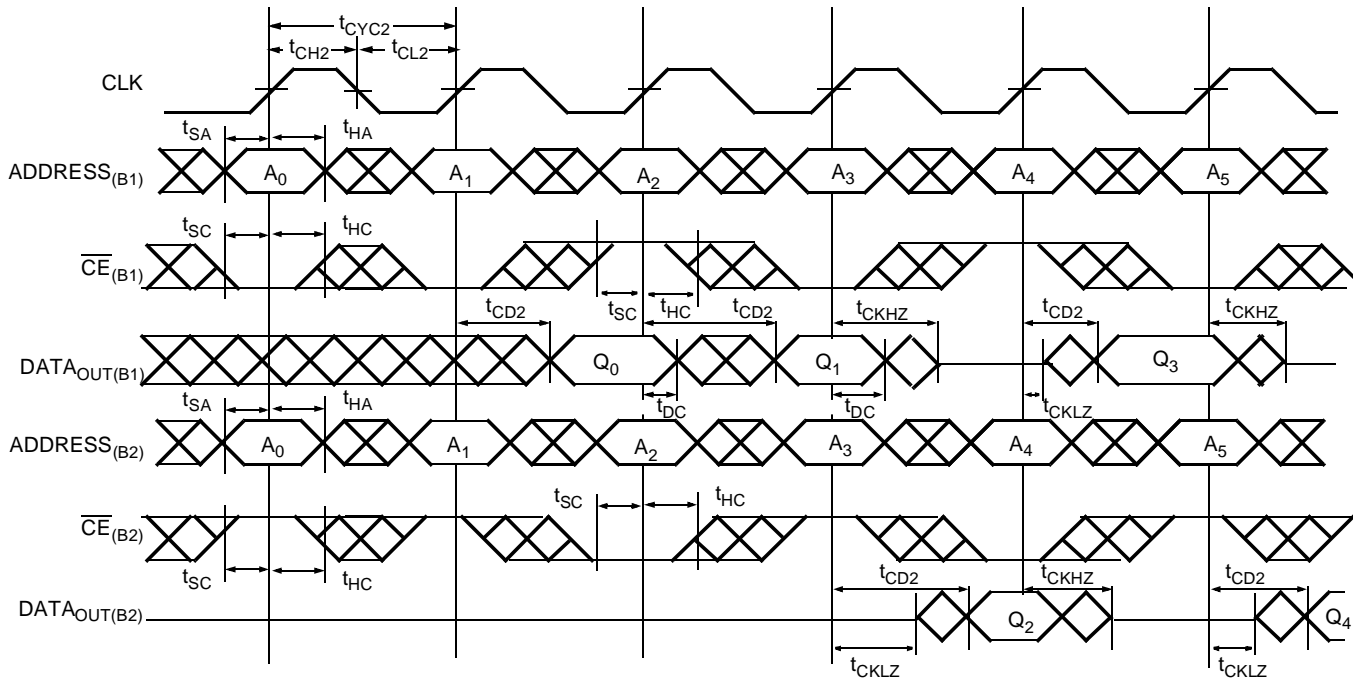
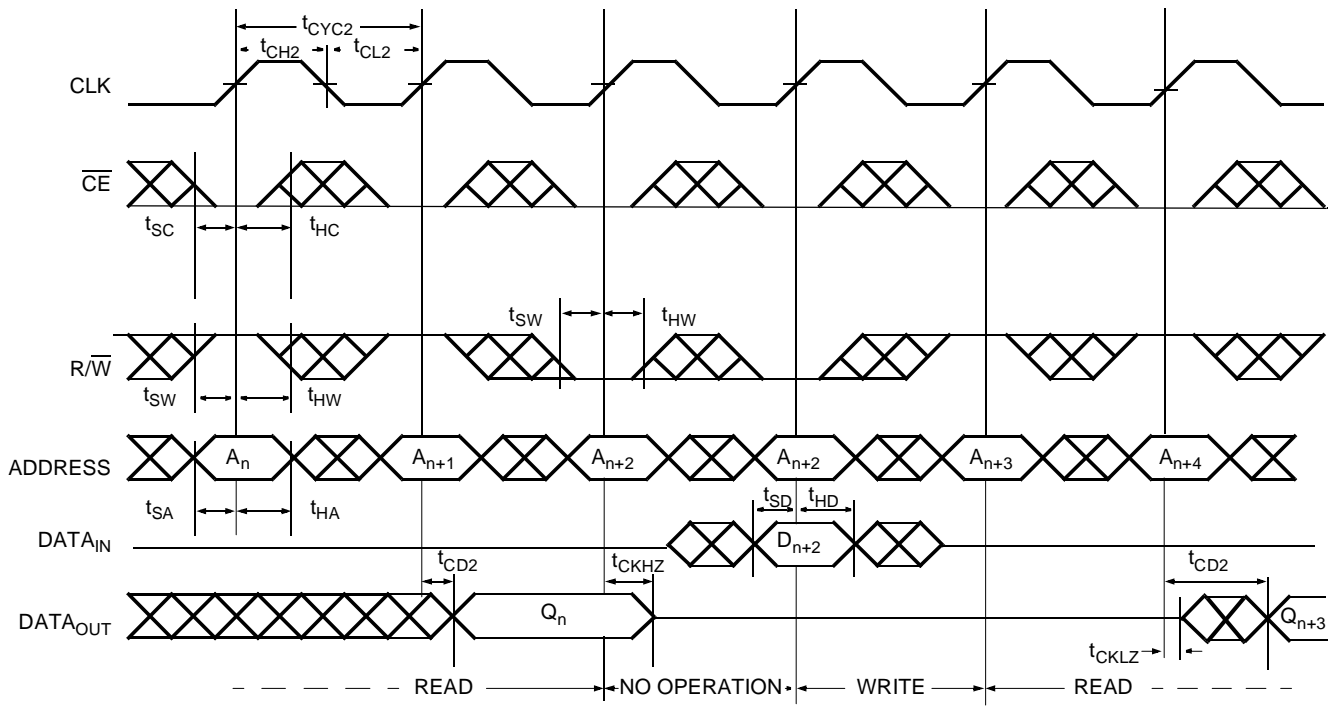
**Notes:**

8.  $\overline{OE}$  is asynchronously controlled; all other inputs (excluding  $\overline{MRST}$ ) are synchronous to the rising clock edge.
9.  $\overline{CNTLD} = V_{IL}$ ,  $\overline{MKLD} = V_{IH}$ ,  $\overline{CNTINC} = x$ , and  $\overline{MRST} = \overline{CNTRST} = V_{IH}$ .
10. The output is disabled (high-impedance state) by  $\overline{CE} = V_{IH}$  following the next rising edge of the clock.
11. Addresses do not have to be accessed sequentially. Note 9 indicates that address is constantly loaded on the rising edge of the CLK. Numbers are for reference only.
12.  $\overline{CE}$  is internal signal.  $\overline{CE} = V_{IL}$  if  $\overline{CE}_0 = V_{IL}$  and  $\overline{CE}_1 = V_{IH}$ .

**Switching Waveforms (continued)**
**Bank Select Read<sup>[13, 14]</sup>**

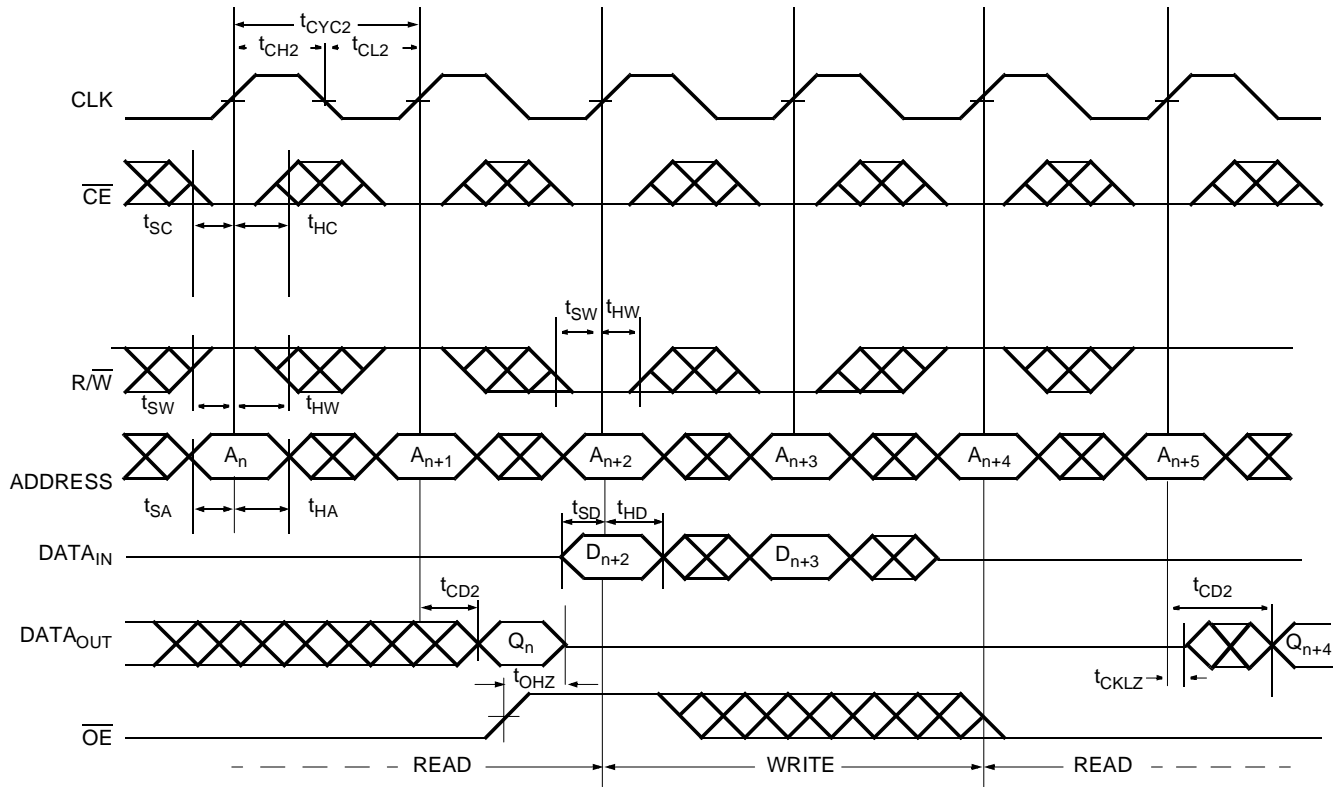
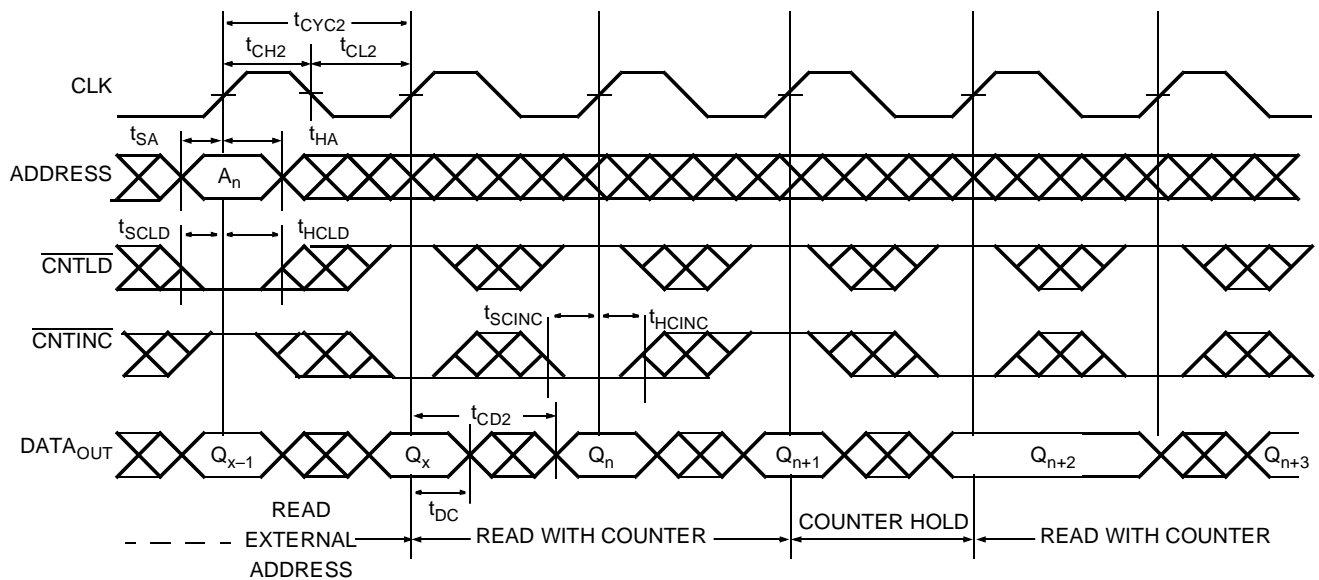
**Read-to-Write-to-Read ( $\overline{OE} = V_{IL}$ )<sup>[15, 16, 17, 18]</sup>**

**Notes:**

13. In this depth expansion example, B1 represents Bank #1 and B2 is Bank #2; Each Bank consists of one Cypress Quadport device from this data sheet.  
 $ADDRESS_{(B1)} = ADDRESS_{(B2)}$   
 $LB = UB = OE = CNTLD = V_{IL}; MRST = CNTRST = MKLD = V_{IH}$ .
14. Output state (HIGH, LOW, or High-Impedance) is determined by the previous cycle control signals.
15.  $LB = UB = CNTLD = V_{IL}; MRST = CNTRST = MKLD = V_{IH}$ .
16. Addresses do not have to be accessed sequentially since  $CNTLD = V_{IL}$  constantly loads the address on the rising edge of the CLK; numbers are for reference only.
17. During "No operation," data in memory at the selected address may be corrupted and should be rewritten to ensure data integrity.

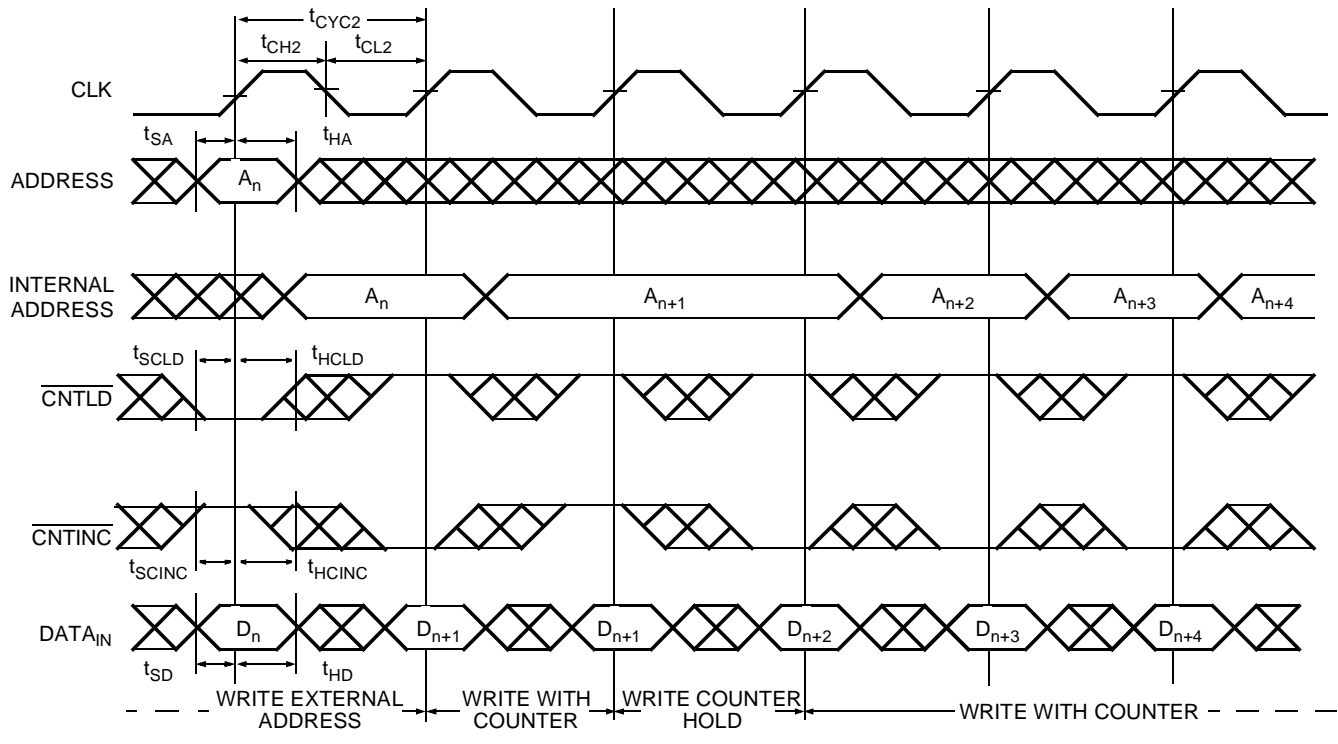
**Switching Waveforms (continued)**
**Read-to-Write-to-Read (OE Controlled)<sup>[15, 16, 17, 18]</sup>**

**Read with Address Counter Advance<sup>[19, 20]</sup>**

**Notes:**

19.  $\overline{CE}_0 = \overline{OE} = \overline{LB} = \overline{UB} = V_{IL}$ ;  $CE_1 = R/W = \overline{CNTRST} = MRST = \overline{MKLD} = \overline{MKRD} = \overline{CNTRD} = V_{IH}$ .
20. The "Internal Address" is equal to the "External Address" when  $CNTLD = V_{IL}$ .

**Switching Waveforms (continued)**
**Write with Address Counter Advance** <sup>[20, 21]</sup>

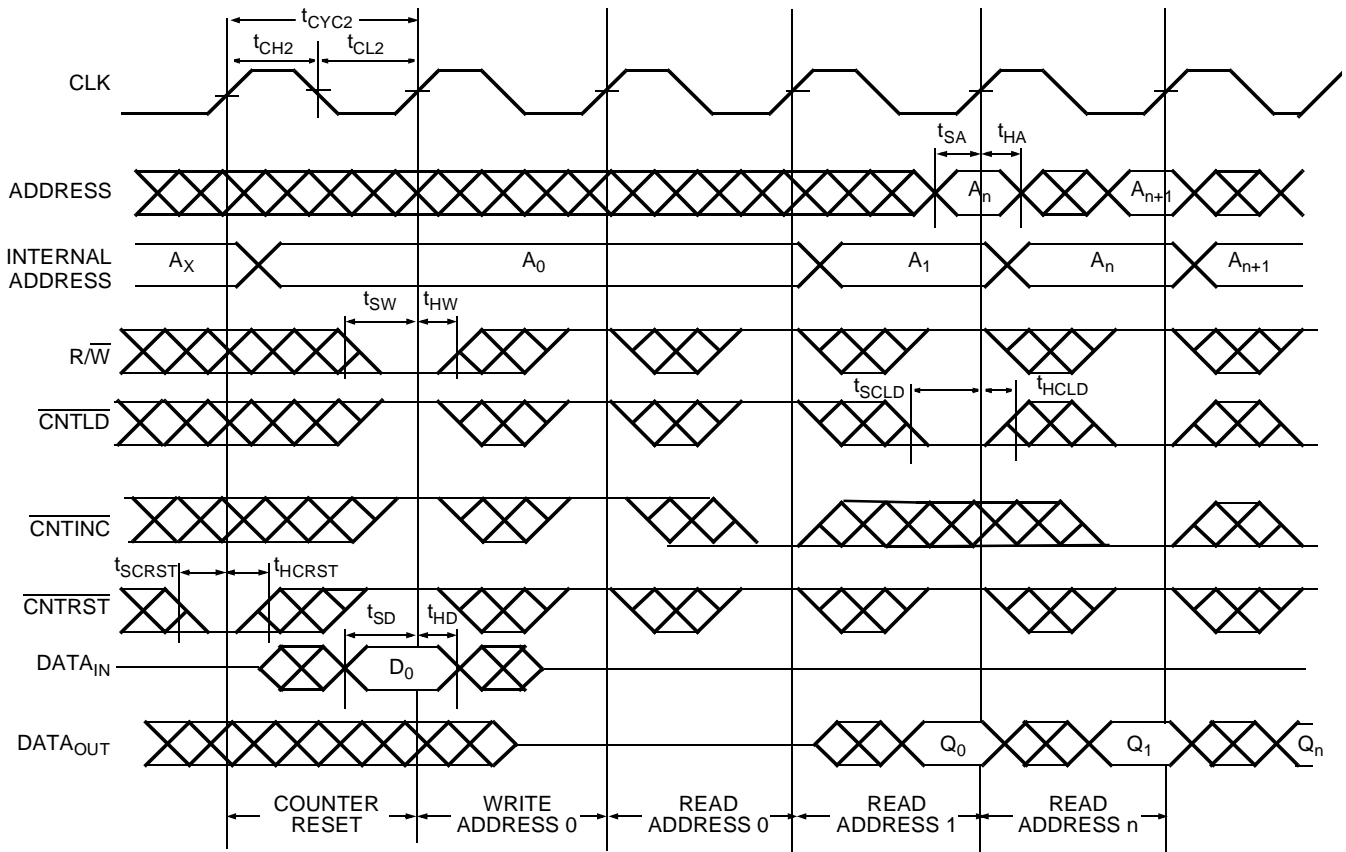
**Note:**

21.  $\overline{CE}_0 = \overline{LB} = \overline{UB} = \overline{R/W} = V_{IL}$ ;  $CE_1 = \overline{CNRST} = \overline{MRST} = \overline{MKLD} = \overline{MKRD} = \overline{CNTRD} = V_{IH}$ .



**Switching Waveforms (continued)**
**Counter Reset [17, 22, 23]**

**Notes:**

22.  $\overline{CE}_0 = \overline{LB} = \overline{UB} = V_{IL}$ ;  $CE_1 = \overline{MRST} = \overline{MKLD} = \overline{MKRD} = \overline{CNTRD} = V_{IH}$ .

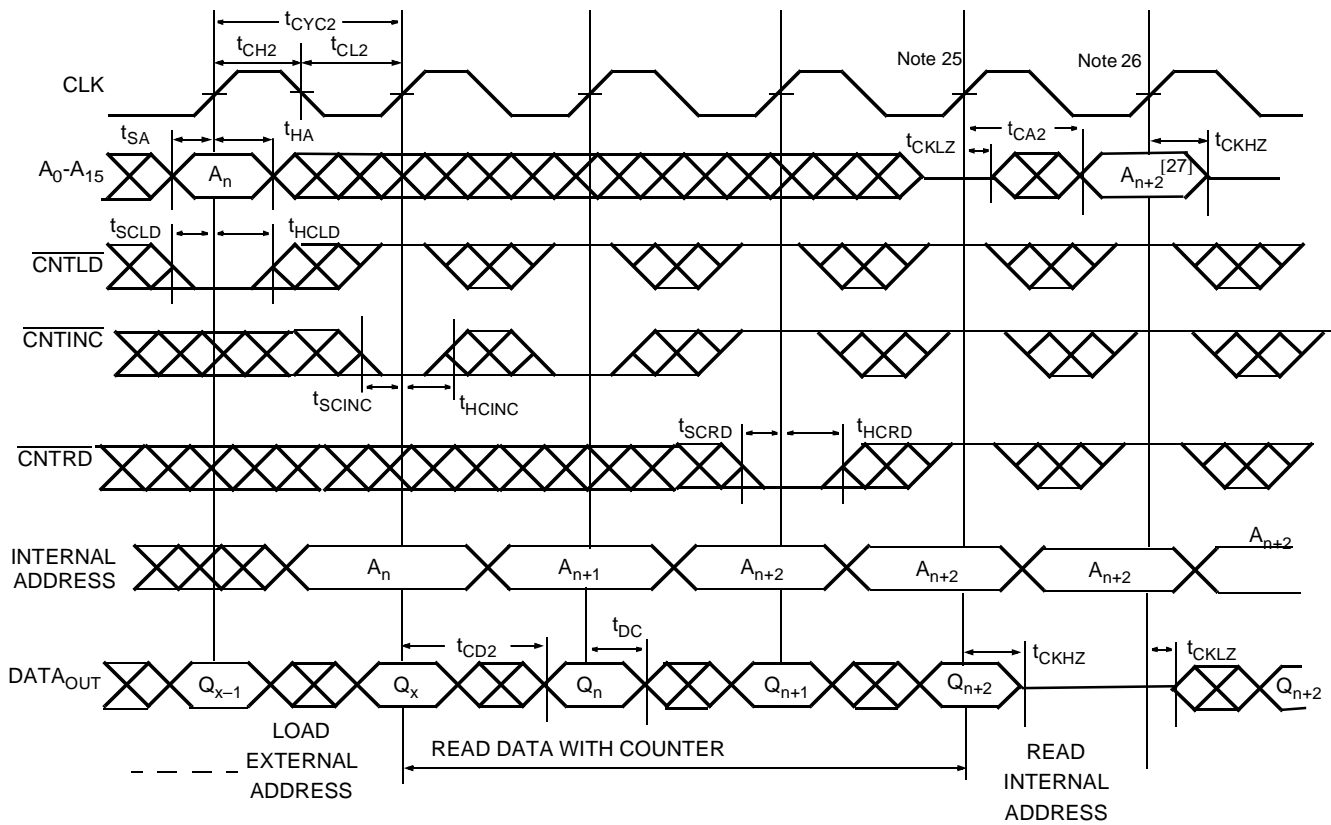
23. No dead cycle exists during counter reset. A READ or WRITE cycle may be coincidental with the counter reset.

**Switching Waveforms (continued)**
**Load and Read Address Counter<sup>[24]</sup>**

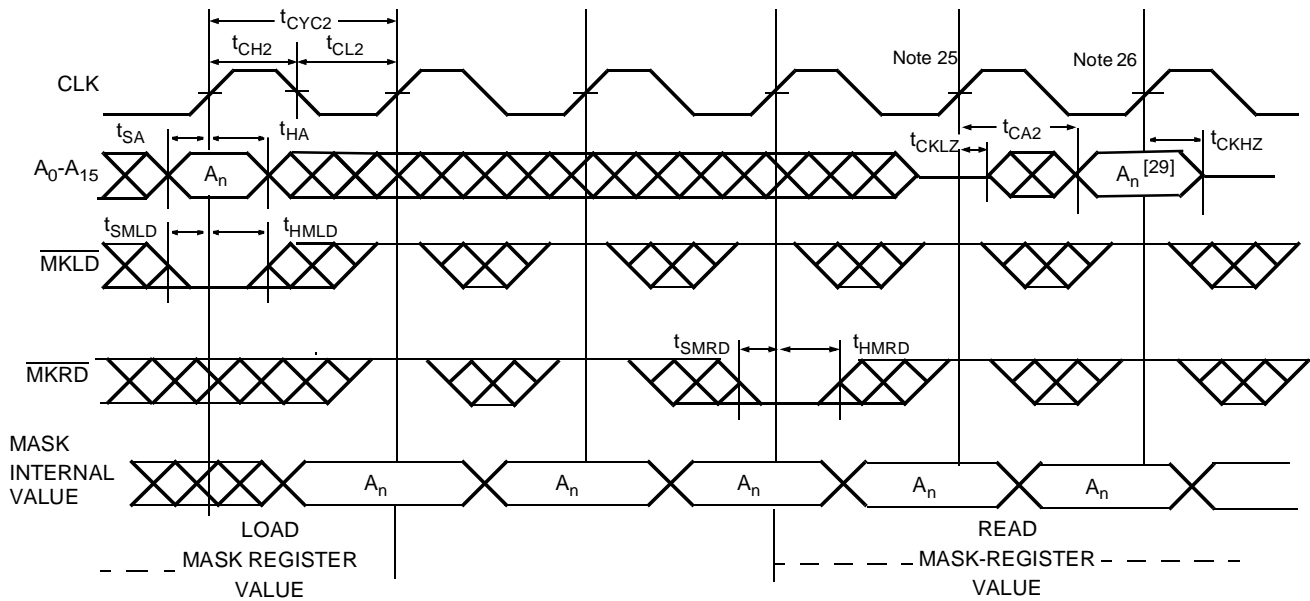
**Notes:**

24.  $\overline{CE}_0 = \overline{OE} = \overline{LB} = \overline{UB} = V_{IL}$ ;  $CE_1 = R/\overline{W} = \overline{CNTRST} = \overline{MRST} = \overline{MKLD} = \overline{MKRD} = V_{IH}$ .
25. Address in output mode. Host must not be driving address bus after time  $t_{CKLZ}$  in next clock cycle.
26. Address in input mode. Host can drive address bus after  $t_{CKHZ}$ .
27. This is the value of the address counter being read out on the address lines.

**Switching Waveforms (continued)**
**Load and Read Mask Register [28]**

**Notes:**

28.  $\overline{CE}_0 = \overline{OE} = \overline{LB} = \overline{UB} = V_{IL}$ ;  $\overline{CE}_1 = R/\overline{W} = \overline{CNTRST} = \overline{MRST} = \overline{CNTLD} = \overline{CNTRD} = \overline{CNTINC} = V_{IH}$ .

29. This is the value of the Mask Register read out on the address lines.

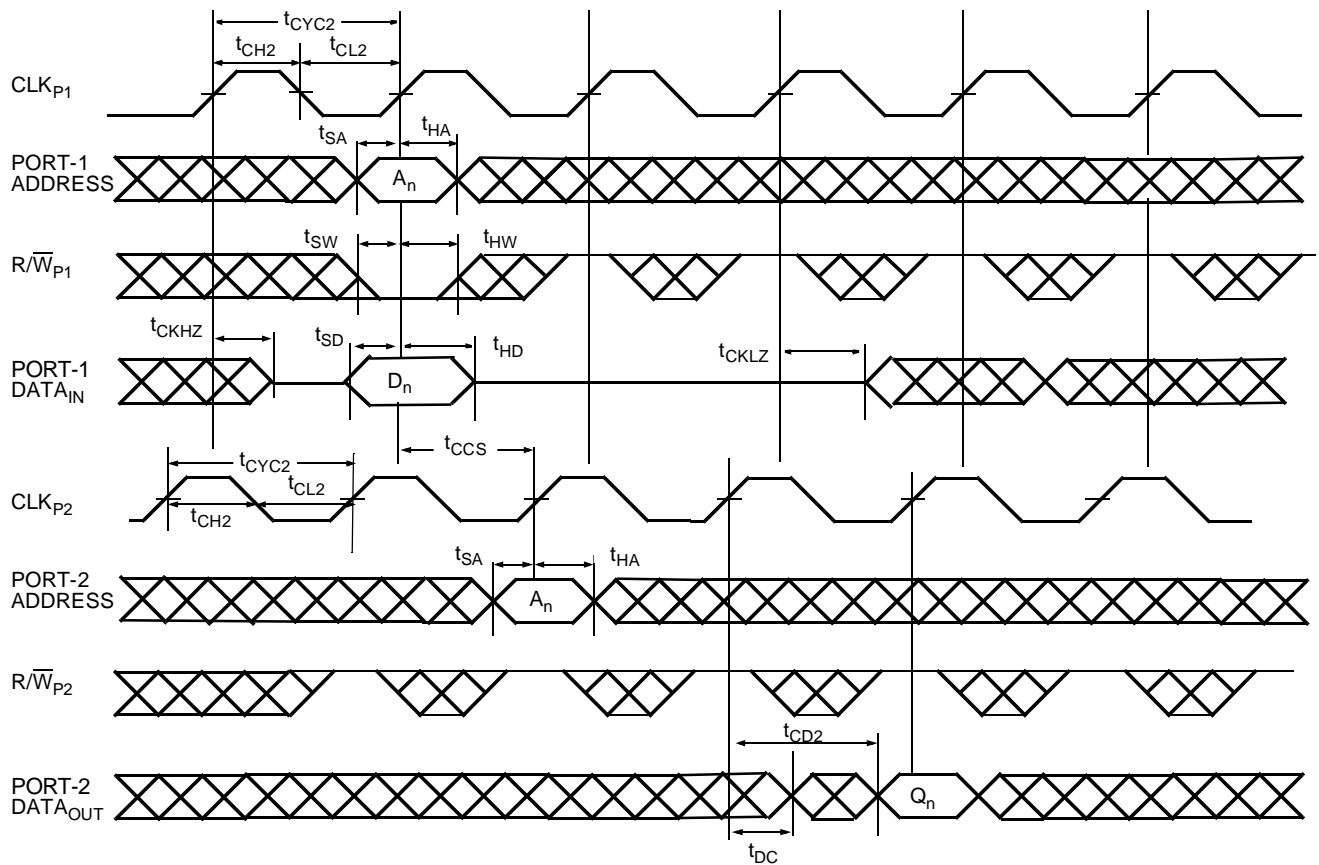
**Switching Waveforms** (continued)



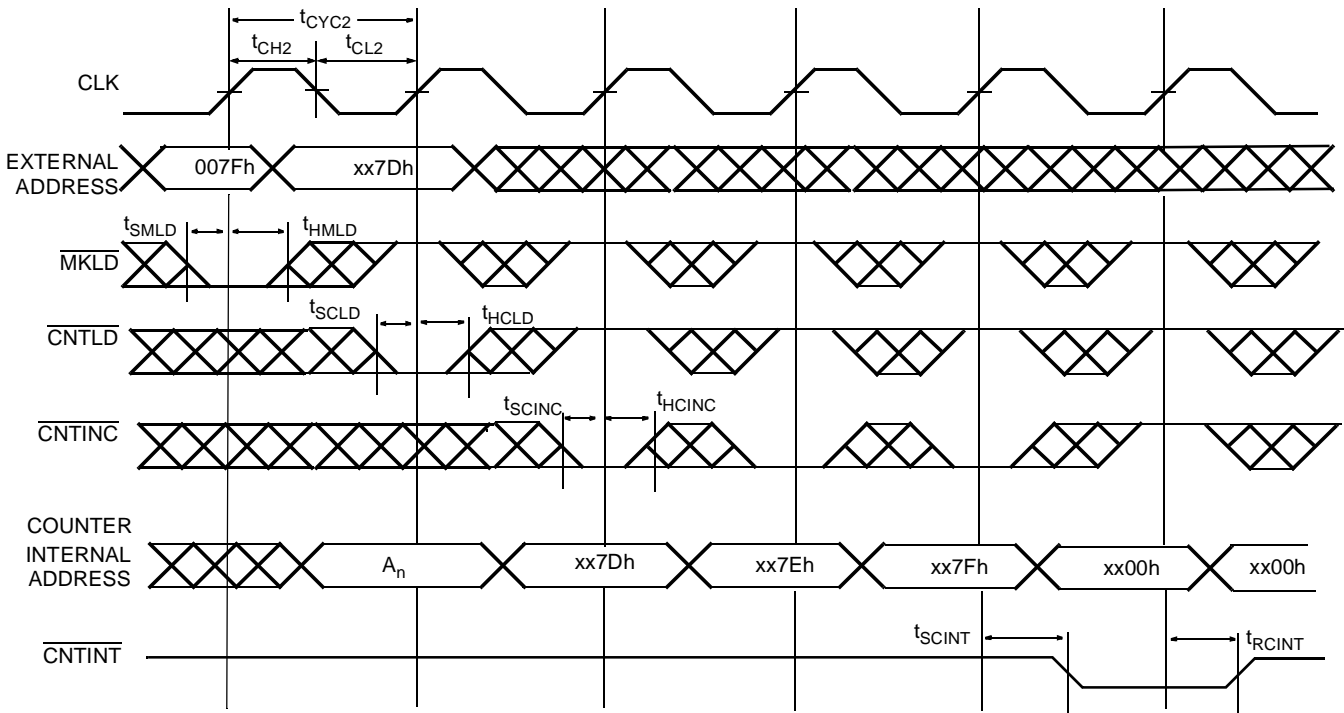
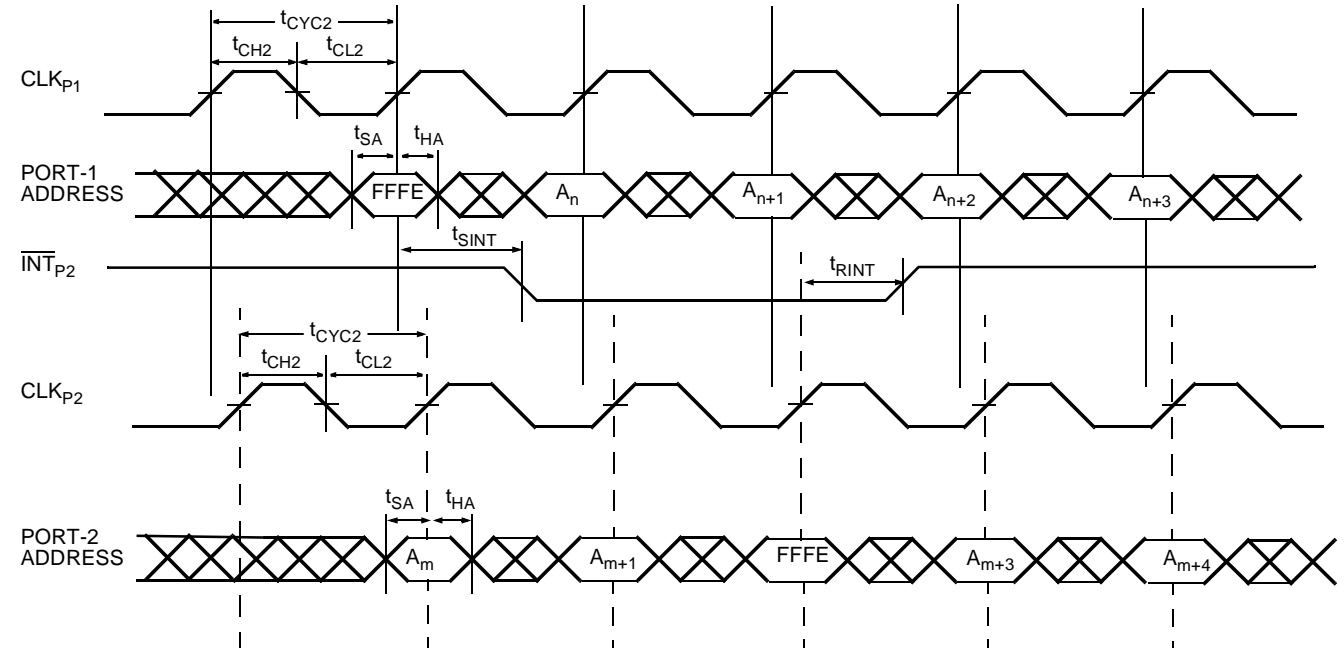

**Port 1 Write to Port 2 Read**<sup>[30, 31, 32]</sup>

**Notes:**

30.  $\overline{CE}_0 = \overline{OE} = \overline{LB} = \overline{UB} = \overline{CNTLD} = V_{IL}$ ;  $CE_1 = \overline{CNTRST} = \overline{MRST} = \overline{MKLD} = \overline{MKRD} = \overline{CNTRD} = \overline{CNTINC} = V_{IH}$ .
31. This timing is valid when one port is writing, and one or more of the three other ports is reading the same location at the same time. If  $t_{CCS}$  is violated, indeterminate data will be read out.
32. If  $t_{CCS} <$  minimum specified value, then Port 2 will read the most recent data (written by Port 1) only ( $2 \cdot t_{CYC2} + t_{CD2}$ ) after the rising edge of Port 2's clock. If  $t_{CCS} \geq$  minimum specified value, then Port 2 will read the most recent data (written by Port 1) ( $t_{CYC2} + t_{CD2}$ ) after the rising edge of Port 2's clock.







**Switching Waveforms (continued)**
**Counter Interrupt [33, 34, 35]**

**Mailbox Interrupt Timing [36, 37, 38, 39, 40]**

**Notes:**

33.  $\overline{CE}_0 = \overline{OE} = \overline{LB} = \overline{UB} = V_{IL}$ ;  $CE_1 = R/\overline{W} = \overline{CNRST} = \overline{MRST} = \overline{CNTRD} = \overline{MKRD} = V_{IH}$ .
34.  $\overline{CNTINT}$  is always driven.
35.  $\overline{CNTINC}$  goes LOW as the counter address masked portion is incremented from xx7Fh to xx00h. The "x" is "don't care."
36.  $\overline{CE}_0 = \overline{OE} = \overline{LB} = \overline{UB} = \overline{CNTLD} = V_{IL}$ ;  $CE_1 = \overline{CNRST} = \overline{MRST} = \overline{CNTRD} = \overline{CNTINC} = \overline{MKRD} = \overline{MKLD} = V_{IH}$ .
37. Address "FFFE" is the mailbox location for Port 2.
38. Port 1 is configured for Write operation, and Port 2 is configured for Read operation.
39. Port 1 and Port 2 are used for simplicity. All four ports can write to or read from any mailbox.
40. Interrupt flag is set with respect to the rising edge of the write clock, and is reset with respect to the rising edge of the read clock.

**Table 1. Read/Write and Enable Operation (Any Port)<sup>[41, 42, 43]</sup>**

Inputs					Outputs	Operation
OE	CLK	CE <sub>0</sub>	CE <sub>1</sub>	R/W	I/O <sub>0</sub> -I/O <sub>17</sub>	
X		H	X	X	High-Z	Deselected
X		X	L	X	High-Z	Deselected
X		L	H	L	D <sub>IN</sub>	Write
L		L	H	H	D <sub>OUT</sub>	Read
H	X	L	H	X	High-Z	Outputs Disabled

**Table 2. Address Counter and Counter-Mask Register Control Operation (Any Port)<sup>[41, 44, 45]</sup>**

CLK	MRST	CNTRST	MKLD	CNTLD	CNTINC	CNTRD	MKRD	Mode	Operation
X	L	X	X	X	X	X	X	Master-Reset	Counter/Address Register Reset and Mask Register Set (resets entire chip as per reset state table)
	H	L	X	X	X	X	X	Reset	Counter/Address Register Reset
	H	H	L	X	X	X	X	Load	Load of Address Lines into Mask Register
	H	H	H	L	X	X	X	Load	Load of Address Lines into Counter/Address Register
	H	H	H	H	L	X	X	Increment	Counter Increment
	H	H	H	H	H	L	X	Read-back	Readback Counter on Address Lines
	H	H	H	H	H	H	L	Read-back	Readback Mask Register on Address Lines
	H	H	H	H	H	H	H	Hold	Counter Hold

**Notes:**

41. "X" = "don't care," "H" = V<sub>IH</sub>, "L" = V<sub>IL</sub>.
42. OE is an asynchronous input signal.
43. When CE changes state, deselection and read happen after one cycle of latency.
44. CE<sub>0</sub> = OE = V<sub>IL</sub>; CE<sub>1</sub> = R/W = V<sub>IH</sub>.
45. Counter operation and mask register operation is independent of Chip Enables.

## Master Reset

The QuadPort undergoes a complete reset by taking its Master Reset (MRST) input LOW. The Master Reset input can switch asynchronously to the clocks. A Master Reset initializes the internal burst counters to zero, and the counter mask registers to all ones (completely unmasked). A Master Reset also forces the Mailbox Interrupt (INT) flags and the Counter Interrupt (CNTINT) flags HIGH, and takes all registered control signals to a deselected read state<sup>46</sup>. A Master Reset must be performed on the QuadPort after power-up.

## Interrupts

The upper four memory locations may be used for message passing and permit communications between ports. *Table 3* shows the interrupt operation for all ports. For the 1-Meg QuadPort, the highest memory location FFFF is the mailbox for Port 1, FFFE is the mailbox for Port 2, FFFD is the mailbox

for Port 3, and FFFC is the mailbox for Port 4. *Table 3* shows that in order to set Port 1  $\overline{\text{INT}}_{\text{P1}}$  flag, a write by any other port to address FFFF will assert  $\overline{\text{INT}}_{\text{P1}}$  LOW. A read of FFFF location by Port 1 will reset  $\overline{\text{INT}}_{\text{P1}}$  HIGH. When one port writes to the other port's mailbox, the Interrupt flag (INT) of the port that the mailbox belongs to is asserted LOW. The Interrupt is reset when the owner (port) of the mailbox reads the contents of the mailbox. The interrupt flag is set in a flow-through mode (i.e., it follows the clock edge of the writing port). Also, the flag is reset in a flow-through mode (i.e., it follows the clock edge of the reading port).

Each port can read the other port's mailbox without resetting the interrupt. If an application does not require message passing, INT pins should be treated as no-connect and should be left floating. When two ports or more write to the same mailbox at the same time  $\overline{\text{INT}}$  will be asserted but the contents of the mailbox are not guaranteed to be valid.

**Table 3. Interrupt Operation Example**

Function	Port 1		Port 2		Port 3		Port 4	
	A <sub>0P1-15P1</sub>	$\overline{\text{INT}}_{\text{P1}}$	A <sub>0P2-15P2</sub>	$\overline{\text{INT}}_{\text{P2}}$	A <sub>0P3-15P3</sub>	$\overline{\text{INT}}_{\text{P3}}$	A <sub>0P4-15P4</sub>	$\overline{\text{INT}}_{\text{P4}}$
Set Port 1 $\overline{\text{INT}}_{\text{P1}}$ Flag	X	L	FFFF	X	FFFF	X	FFFF	X
Reset Port 1 $\overline{\text{INT}}_{\text{P1}}$ Flag	FFFF	H	X	X	X	X	X	X
Set Port 2 $\overline{\text{INT}}_{\text{P2}}$ Flag	FFFE	X	X	L	FFFE	X	FFFE	X
Reset Port 2 $\overline{\text{INT}}_{\text{P2}}$ Flag	X	X	FFFE	H	X	X	X	X
Set Port 3 $\overline{\text{INT}}_{\text{P3}}$ Flag	FFFD	X	FFFD	X	X	L	FFFD	X
Reset Port 3 $\overline{\text{INT}}_{\text{P3}}$ Flag	X	X	X	X	FFFD	H	X	X
Set Port 4 $\overline{\text{INT}}_{\text{P4}}$ Flag	FFFC	X	FFFC	X	FFFC	X	X	L
Reset Port 4 $\overline{\text{INT}}_{\text{P4}}$ Flag	X	X	X	X	X	X	FFFC	H

**Note:**

46. During Master Reset the control signals will be set to a deselected read state:  $\overline{\text{CE}}_{01} = \overline{\text{LB}}\overline{\text{I}} = \overline{\text{UB}}\overline{\text{I}} = \text{R}/\overline{\text{WI}} = \overline{\text{MKLD}}\overline{\text{I}} = \overline{\text{MKRD}}\overline{\text{I}} = \overline{\text{CNTRD}}\overline{\text{I}} = \overline{\text{CNTRST}}\overline{\text{I}} = \overline{\text{CNTLD}}\overline{\text{I}} = \overline{\text{CNTINC}}\overline{\text{I}} = \text{V}_{\text{IH}}$ ;  $\text{CE}_{11} = \text{V}_{\text{IL}}$ . The "I" suffix on all these signals denotes that these are the internal registered equivalent of the associated pin signals.

### Address Counter Control Operations

Counter enable inputs are provided to stall the operation of the address input and utilize the internal address generated by the internal counter for the fast interleaved memory applications. A port's burst counter is loaded with the port's Counter Load pin (CNTLD). When the port's Counter Increment (CNTINC) is asserted, the address counter will increment on each LOW to HIGH transition of that port's clock signal. This will read/write one word from/into each successive address location until CNTINC is deasserted. Depending on the mask register state, the counter can address the entire memory array and will loop back to start. Counter Reset (CNTRST) is used to reset the Burst Counter (the Mask Register value is unaffected). When using the counter in readback mode, the internal address value of the counter will be read back on the address lines when Counter Readback Signal (CNTRD) is asserted. Figure 1 pro-

vides a block diagram of the readback operation. Table 2 lists control signals required for counter operations. The signals are listed based on their priority. For example, master reset takes precedence over counter reset, and counter load has lower priority than mask register load (described below). All counter operations are independent of Chip Enables (CE<sub>0</sub> and CE<sub>1</sub>). When the address readback operation is performed the data I/Os are three-stated (if CEs are active) and one-clock cycle (no-operation cycle) latency is experienced. The address will be read at time t<sub>CA2</sub> from the rising edge of the clock following the no-operation cycle. The read back address can be either of the burst counter or the mask register based on the levels of Counter Read signal (CNTRD) and Mask Register Read signal (MKRD). Both signals are synchronized to the port's clock as shown in Table 2. Counter read has a higher priority than mask read.

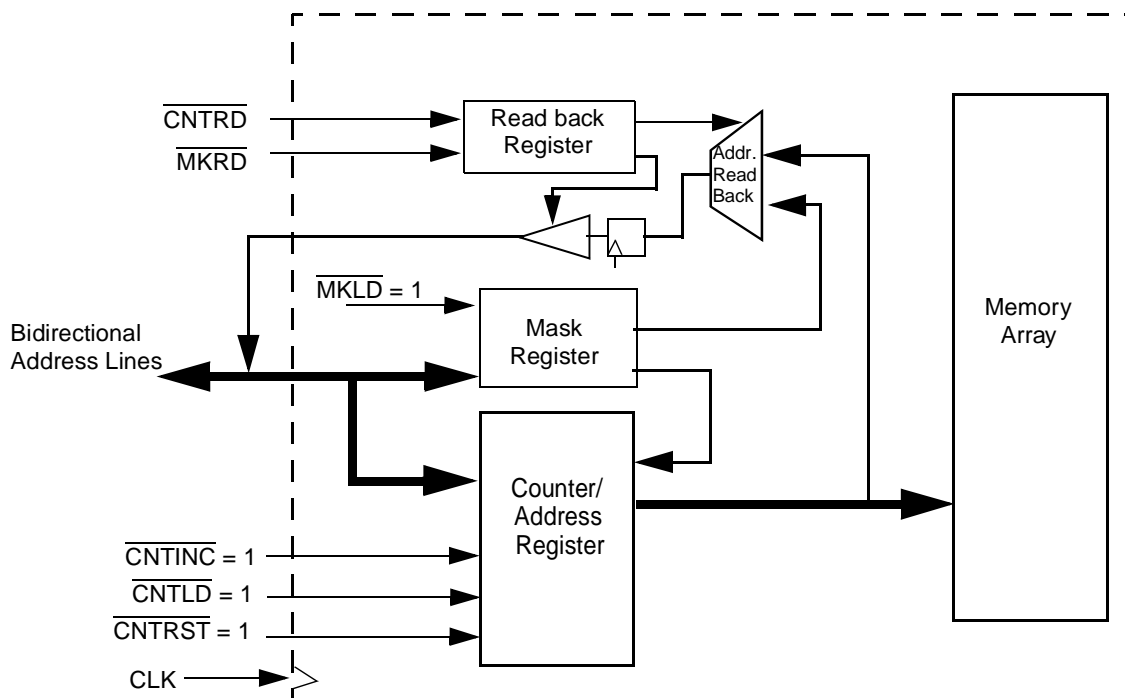

**Figure 1. Counter and Mask Register Read Back on Address Lines**

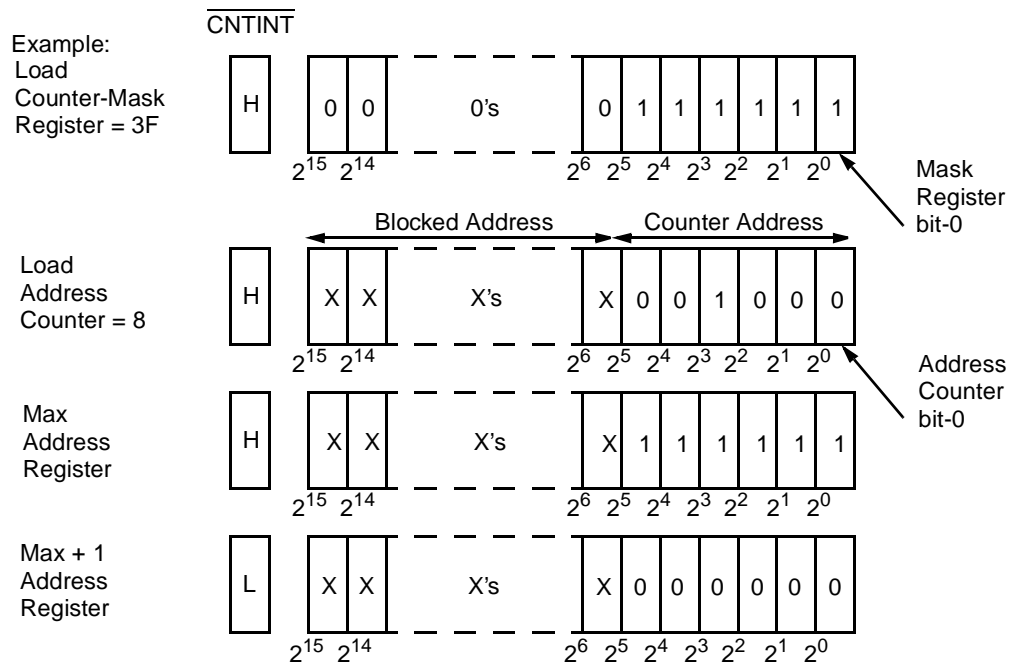

**Counter-Mask Register**

**Figure 2. Programmable Counter-Mask Register Operation<sup>[47]</sup>**
**Note:**

47. The "X" in this diagram represents the counter upper-bits.

The burst counter has a mask register that controls when and where the counter wraps. An interrupt flag (CNTINT) is asserted for one clock cycle when the unmasked portion of the counter address wraps around from all ones (CNTINC must be asserted) to all zeros. The example in Figure 2 shows the counter mask register loaded with a mask value of 003F unmasking the first 6 bits with bit "0" as the LSB and bit "15" as the MSB. The maximum value the mask register can be loaded with is FFFF. Setting the mask register to this value allows the counter to access the entire memory space. The address counter is then loaded with an initial value of XXX8. The "blocked" addresses (in this case, the 6th address through the 15th address) are loaded with an address but do not increment once loaded. The counter address will start at address XXX8. With CNTINC asserted LOW, the counter will increment its internal address value till it reaches the mask register value of 3F and wraps around the memory block to location XXX0. Therefore, the counter uses the mask-register to define wrap-around point. The mask register of every port is loaded when MKLD (mask register load) for that port is LOW. When MKRD is LOW, the value of the mask register can be read out on address lines in a manner similar to counter read back operation (see Table 2 for required conditions).

When the burst counter is loaded with an address higher than the mask register value, the higher addresses will form the masked portion of the counter address and are called blocked addresses. The blocked addresses will not be changed or affected by the counter increment operation. The only exception is mask register bit 0. It can be masked to allow the address counter to increment by two. If the mask register bit 0 is loaded with a logic value of "0," then address counter bit 0 is masked and can not be changed during counter increment operation. If the loaded value for address counter bit 0 is "0," the counter

will increment by two and the address values are even. If the loaded value for address counter bit 0 is "1," the counter will increment by two and the address values are odd. This operation allows the user to achieve a 36-bit interface using any two ports, where the counter of one port counts even addresses and the counter of the other port counts odd addresses. This even-odd address scheme stores one half of the 36-bit word in even memory locations, and the other half in odd memory locations. CNTINT will be asserted when the unmasked portion of the counter wraps to all zeros. Loading mask register bit 0 with "1" allows the counter to increment the address value sequentially.

Table 2 groups the operations of the mask register with the operations of the address counter. Address counter and mask register signals are all synchronized to the port's clock CLK. Master reset (MRST) is the only asynchronous signal listed on Table 2. Signals are listed based on their priority going from left column to right column with MRST being the highest. A LOW on MRST will reset both counter register to all zeros and mask register to all ones. On the other hand, a LOW on CNTRST will only clear the address counter register to zeros and the mask register will remain intact.

There are four operations for the counter and mask register:

1. Load operation: When CNTLD or MKLD is LOW, the address counter or the mask register is loaded with the address value presented at the address lines. This value ranges from 0 to FFFF (64K). The mask register load operation has a higher priority over the address counter load operation.
2. Increment: Once the address counter is loaded with an external address, the counter can internally increment the ad-

dress value by asserting  $\overline{\text{CNTINC}}$  LOW. The counter can address the entire memory array (depend on the value of the mask register) and loop back to location 0. The increment operation is second in priority to load operation.

3. Readback: the internal value of either the burst counter or the mask register can be read out on the address lines when  $\text{CNTRD}$  or  $\text{MKRD}$  is LOW. Counter readback has higher priority over mask register readback. A no-operation delay cycle is experienced when readback operation is performed. The address will be valid after  $t_{\text{CA}2}$  (for counter readback) or  $t_{\text{CM}2}$  (for mask readback) from the following port's clock rising edge. Address readback operation is independent of the port's chip enables ( $\text{CE}_0$  and  $\text{CE}_1$ ). If address readback occurs while the port is enabled (chip enables active), the data lines (I/Os) will be three-stated.
4. Hold operation: In order to hold the value of the address counter at certain address, all signals in *Table 2* have to be HIGH. This operation has the least priority. This operation is useful in many applications where wait states are needed or when address is available few cycles ahead of data.

The counter and mask register operations are totally independent of port chip enables.

## IEEE 1149.1 Serial Boundary Scan (JTAG)

The CY7C0430V incorporates a serial boundary scan test access port (TAP). This port operates in accordance with IEEE Standard 1149.1-1900. Note that the TAP controller functions in a manner that does not conflict with the operation of other devices using 1149.1 fully compliant TAPs. The TAP operates using JEDEC standard 3.3V I/O logic levels. It is composed of three input connections and one output connection required by the test logic defined by the standard. Disabling the JTAG Feature

It is possible to operate the QuadPort without using the JTAG feature. To disable the TAP controller, TCK must be tied LOW ( $V_{\text{SS}}$ ) to prevent clocking of the device. TDI and TMS are internally pulled up and may be unconnected. They may alternately be connected to VDD through a pull-up resistor. TDO should be left unconnected. Upon power-up, the device will come up in a reset state which will not interfere with the operation of the device.

### Test Access Port (TAP) - Test Clock (TCK)

The test clock is used only with the TAP controller. All inputs are captured on the rising edge of TCK. All outputs are driven from the falling edge of TCK.

### Test Mode Select

The TMS input is used to give commands to the TAP controller and is sampled on the rising edge of TCK. It is allowable to leave this pin unconnected if the TAP is not used. The pin is pulled up internally, resulting in a logic HIGH level.

### Test Data-In (TDI)

The TDI pin is used to serially input information into the registers and can be connected to the input of any of the registers. The register between TDI and TDO is chosen by the instruction that is loaded into the TAP instruction register. For information on loading the instruction register, see the TAP Controller State Diagram. TDI is internally pulled up and can be unconnected if the TAP is unused in an application. TDI is connected to the most significant bit (MSB) on any register.

### Test Data Out (TDO)

The TDO output pin is used to serially clock data-out from the registers. The output is active depending upon the current state of the TAP state machine (see TAP Controller State Diagram (FSM)). The output changes on the falling edge of TCK. TDO is connected to the least significant bit (LSB) of any register.

### Performing a TAP Reset

A Reset is performed by forcing TMS HIGH ( $V_{\text{DD}}$ ) for five rising edges of TCK. This RESET does not affect the operation of the QuadPort and may be performed while the device is operating. At power-up, the TAP is reset internally to ensure that TDO comes up in a high-Z state.

### TAP Registers

Registers are connected between the TDI and TDO pins and allow data to be scanned into and out of the QuadPort test circuitry. Only one register can be selected at a time through the instruction registers. Data is serially loaded into the TDI pin on the rising edge of TCK. Data is output on the TDO pin on the falling edge of TCK.

### Instruction Register

Four-bit instructions can be serially loaded into the instruction register. This register is loaded when it is placed between the TDI and TDO pins as shown in the following JTAG Controller diagram. Upon power-up, the instruction register is loaded with the IDCODE instruction. It is also loaded with the IDCODE instruction if the controller is placed in a reset state as described in the previous section.

When the TAP controller is in the CaptureIR state, the two least significant bits are loaded with a binary "01" pattern to allow for fault isolation of the board level serial test path.

### Bypass Register

To save time when serially shifting data through registers, it is sometimes advantageous to skip certain devices. The bypass register is a single-bit register that can be placed between TDI and TDO pins. This allows data to be shifted through the QuadPort with minimal delay. The bypass register is set LOW ( $V_{\text{SS}}$ ) when the BYPASS instruction is executed.

### Boundary Scan Register

The boundary scan register is connected to all the input and output pins on the QuadPort. The boundary scan register is loaded with the contents of the QP Input and Output ring when the TAP controller is in the Capture-DR state and is then placed between the TDI and TDO pins when the controller is moved to the Shift-DR state. The EXTEST, and SAMPLE/PRELOAD instructions can be used to capture the contents of the Input and Output ring.

### Identification (ID) Register

The ID register is loaded with a vendor-specific, 32-bit code during the Capture-DR state when the IDCODE command is loaded in the instruction register. The IDCODE is hardwired into the QuadPort and can be shifted out when the TAP controller is in the Shift-DR state. The ID register has a vendor code and other information described in the Identification Register Definitions table.

## TAP Instruction Set

Sixteen different instructions are possible with the 4-bit instruction register. All combinations are listed in *Table 6*, Instruction Codes. Seven of these instructions (codes) are listed as RESERVED and should not be used. The other nine instructions are described in detail below.

The TAP controller used in this QuadPort is fully compliant to the 1149.1 convention. The TAP controller can be used to load address, data or control signals into the QuadPort and can preload the Input or output buffers. The QuadPort implements all of the 1149.1 instructions except INTEST. *Table 6* lists all instructions.

Instructions are loaded into the TAP controller during the Shift-IR state when the instruction register is placed between TDI and TDO. During this state, instructions are shifted through the instruction register through the TDI and TDO pins. To execute the instruction once it is shifted in, the TAP controller needs to be moved into the Update-IR state.

### EXTEST

EXTEST is a mandatory 1149.1 instruction which is to be executed whenever the instruction register is loaded with all 0s. EXTEST allows circuitry external to the QuadPort package to be tested. Boundary-scan register cells at output pins are used to apply test stimuli, while those at input pins capture test results.

### IDCODE

The IDCODE instruction causes a vendor-specific, 32-bit code to be loaded into the instruction register. It also places the instruction register between the TDI and TDO pins and allows the IDCODE to be shifted out of the device when the TAP controller enters the Shift-DR state. The IDCODE instruction is loaded into the instruction register upon power-up or whenever the TAP controller is given a test logic reset state.

### High-Z

The High-Z instruction causes the boundary scan register to be connected between the TDI and TDO pins when the TAP controller is in a Shift-DR state. It also places all QuadPort outputs into a High-Z state.

### SAMPLE / PRELOAD

SAMPLE / PRELOAD is a 1149.1 mandatory instruction. When the SAMPLE / PRELOAD instructions loaded into the

instruction register and the TAP controller in the Capture-DR state, a snapshot of data on the inputs and output pins is captured in the boundary scan register.

The user must be aware that the TAP controller clock can only operate at a frequency up to 10 MHz, while the QuadPort clock operates more than an order of magnitude faster. Because there is a large difference in the clock frequencies, it is possible that during the Capture-DR state, an input or output will undergo a transition. The TAP may then try to capture a signal while in transition (metastable state). This will not harm the device, but there is no guarantee as to the value that will be captured. Repeatable results may not be possible.

To guarantee that the boundary scan register will capture the correct value of a signal, the QuadPort signal must be stabilized long enough to meet the TAP controller's capture set-up plus hold times. Once the data is captured, it is possible to shift out the data by putting the TAP into the Shift-DR state. This places the boundary scan register between the TDI and TDO pins. If the TAP controller goes into the Update-DR state, the sampled data will be updated.

### BYPASS

When the BYPASS instruction is loaded in the instruction register and the TAP is placed in a Shift-DR state, the bypass register is placed between the TDI and TDO pins. The advantage of the BYPASS instruction is that it shortens the boundary scan path when multiple devices are connected together on a board.

### CLAMP

The optional CLAMP instruction allows the state of the signals driven from QuadPort pins to be determined from the boundary-scan register while the BYPASS register is selected as the serial path between TDI and TDO. CLAMP controls boundary cells to 1 or 0.

## Boundary Scan Cells (BSC)

*Table 7* lists all QuadPort I/Os with their associated BSC. Notice that the cells have even numbers. Every I/O has two boundary scan cells. Bidirectional signals (address lines, data-lines) require two cells so that one (the odd cell) is used to control a three-state buffer. Input only and output only signals have an extra dummy cell (odd cells) that are used to ease device layout.

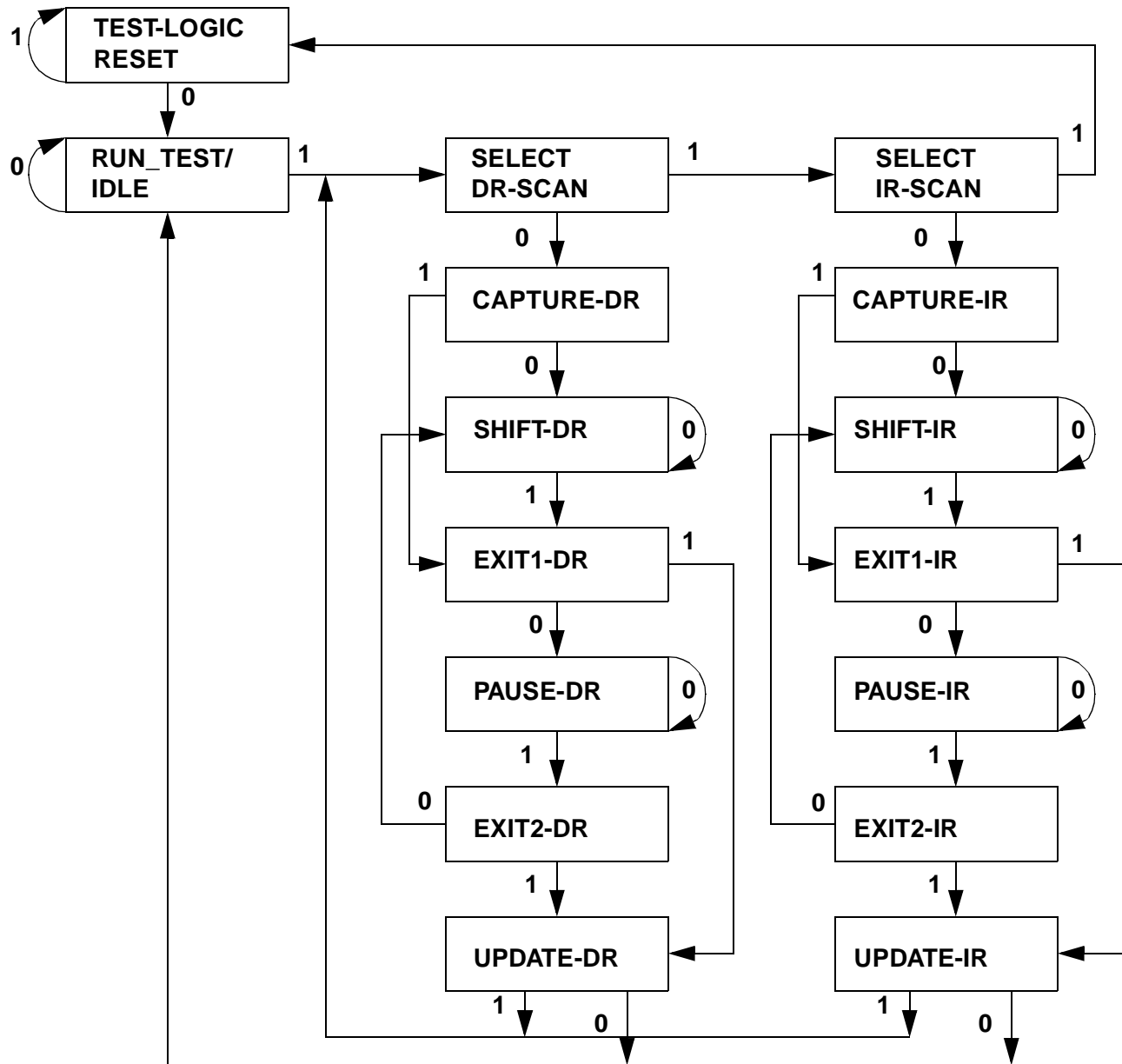
**TAP Controller State Diagram (FSM)<sup>[48]</sup>**

**Note:**

48. The 0/1 next to each state represents the value at TMS at the rising edge of TCK.

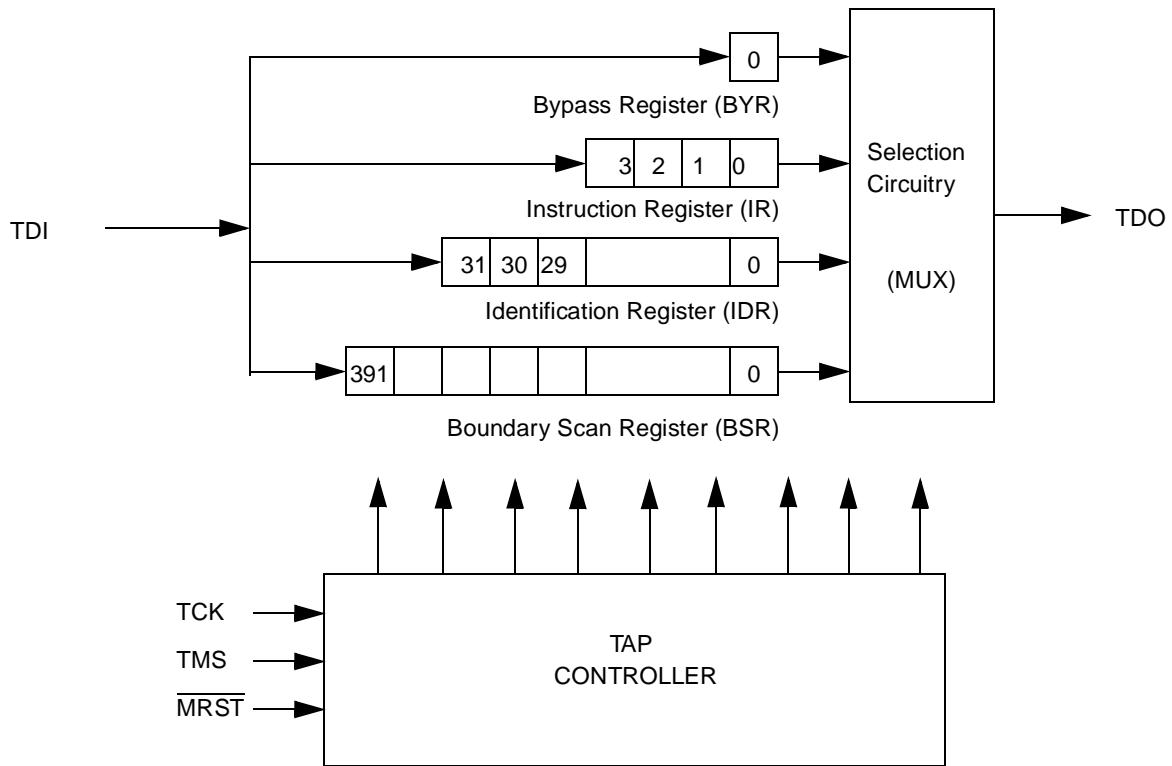
**JTAG TAP Controller Block Diagram**

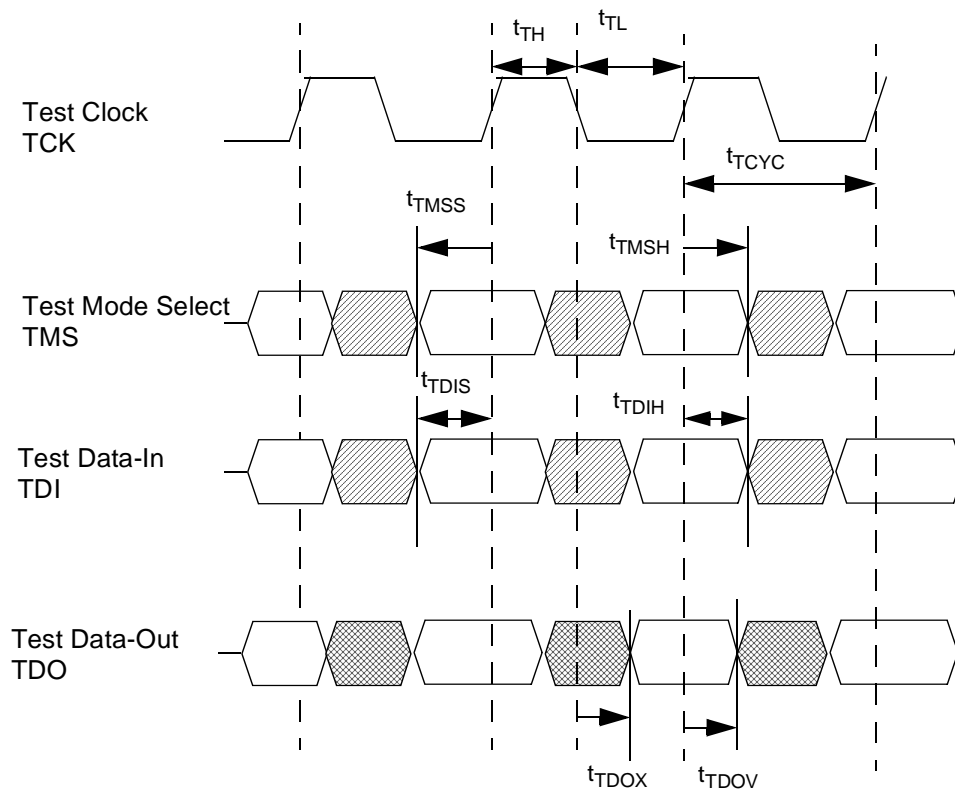

**JTAG Timing Waveform**

**Table 4. Identification Register Definitions**

Instruction Field	Value	Description
Revision Number (31:28)	1h	Reserved for version number
Cypress Device ID (27:12)	C000h	Defines Cypress part number
Cypress JEDEC ID (11:1)	34h	Allows unique identification of QuadPort vendor
ID Register Presence (0)	1	Indicate the presence of an ID register

**Table 5. Scan Registers Sizes**

Register Name	Bit Size
Instruction (IR)	4
Bypass (BYR)	1
Identification (IDR)	32
Boundary Scan (BSR)	392

**Table 6. Instruction Identification Codes**

Instruction	Code	Description
EXTEST	0000	Captures the Input/Output ring contents. Places the boundary scan register (BSR) between the TDI and TDO.
BYPASS	1111	Places the bypass register (BYR) between TDI and TDO.
IDCODE	0111	Loads the ID register (IDR) with the vendor ID code and places the register between TDI and TDO.
HIGHZ	0110	Places the BYR between TDI and TDO. Forces all QuadPort output drivers to a High-Z state.
CLAMP	0101	Controls boundary to 1/0. Uses BYR.
SAMPLE/PRELOAD	0001	Captures the Input/Output ring contents. Places the boundary scan register (BSR) between TDI and TDO.
RESERVED	All other codes	Seven combinations are reserved. Do not use other than the above.

**Table 7. Boundary Scan Order**

Cell #	Signal Name	Bump (Ball) ID
2	A0_P4	K20
4	A1_P4	J19
6	A2_P4	J18
8	A3_P4	H20
10	A4_P4	H19
12	A5_P4	G19
14	A6_P4	G18
16	A7_P4	F20
18	A8_P4	F19
20	A9_P4	F18
22	A10_P4	E20
24	A11_P4	E19
26	A12_P4	D19
28	A13_P4	D18
30	A14_P4	C20
32	A15_P4	C19
34	$\overline{\text{CNTINT}}_{\text{P4}}$	F17
36	$\overline{\text{CNTRST}}_{\text{P4}}$	K18
38	$\overline{\text{MKLD}}_{\text{P4}}$	H18
40	$\overline{\text{CNTLD}}_{\text{P4}}$	H17
42	$\overline{\text{CNTINC}}_{\text{P4}}$	G17
44	$\overline{\text{CNTRD}}_{\text{P4}}$	E17
46	$\overline{\text{MKRD}}_{\text{P4}}$	E18
48	$\overline{\text{LB}}_{\text{P4}}$	A20
50	$\overline{\text{UB}}_{\text{P4}}$	B19
52	$\overline{\text{OE}}_{\text{P4}}$	D17
54	$\overline{\text{R/W}}_{\text{P4}}$	C16
56	$\overline{\text{CE1}}_{\text{P4}}$	C18
58	$\overline{\text{CE0}}_{\text{P4}}$	C17
60	$\overline{\text{INT}}_{\text{P4}}$	K19
62	CLK_P4	K17
64	A0_P3	L20
66	A1_P3	M19
68	A2_P3	M18
70	A3_P3	N20
72	A4_P3	N19
74	A5_P3	P19
76	A6_P3	P18
78	A7_P3	R20
80	A8_P3	R19
82	A9_P3	R18

**Table 7. Boundary Scan Order (continued)**

Cell #	Signal Name	Bump (Ball) ID
84	A10_P3	T20
86	A11_P3	T19
88	A12_P3	U19
90	A13_P3	U18
92	A14_P3	V20
94	A15_P3	V19
96	$\overline{\text{CNTINT}}_{\text{P3}}$	R17
98	$\overline{\text{CNTRST}}_{\text{P3}}$	L18
100	$\overline{\text{MKLD}}_{\text{P3}}$	N18
102	$\overline{\text{CNTLD}}_{\text{P3}}$	N17
104	$\overline{\text{CNTINC}}_{\text{P3}}$	P17
106	$\overline{\text{CNTRD}}_{\text{P3}}$	T17
108	$\overline{\text{MKRD}}_{\text{P3}}$	T18
110	$\overline{\text{LB}}_{\text{P3}}$	Y20
112	$\overline{\text{UB}}_{\text{P3}}$	W19
114	$\overline{\text{OE}}_{\text{P3}}$	U17
116	$\overline{\text{R/W}}_{\text{P3}}$	V16
118	CE1_P3	V18
120	CE0_P3	V17
122	$\overline{\text{INT}}_{\text{P3}}$	L19
124	CLK_P3	M17
126	IO0_P4	Y15
128	IO1_P4	W15
130	IO2_P4	Y16
132	IO3_P4	W16
134	IO4_P4	Y17
136	IO5_P4	W17
138	IO6_P4	Y18
140	IO7_P4	W18
142	IO8_P4	Y19
144	IO0_P3	V12
146	IO1_P3	Y11
148	IO2_P3	W12
150	IO3_P3	Y12
152	IO4_P3	W13
154	IO5_P3	Y13
156	IO6_P3	V15
158	IO7_P3	Y14
160	IO8_P3	W14
162	IO0_P1	Y6
164	IO1_P1	W6



**Table 7. Boundary Scan Order** (continued)

Cell #	Signal Name	Bump (Ball) ID
166	IO2_P1	Y5
168	IO3_P1	W5
170	IO4_P1	Y4
172	IO5_P1	W4
174	IO6_P1	Y3
176	IO7_P1	W3
178	IO8_P1	Y2
180	IO0_P2	V9
182	IO1_P2	Y10
184	IO2_P2	W9
186	IO3_P2	Y9
188	IO4_P2	W8
190	IO5_P2	Y8
192	IO6_P2	V6
194	IO7_P2	Y7
196	IO8_P2	W7
198	A0_P2	L1
200	A1_P2	M2
202	A2_P2	M3
204	A3_P2	N1
206	A4_P2	N2
208	A5_P2	P2
210	A6_P2	P3
212	A7_P2	R1
214	A8_P2	R2
216	A9_P2	R3
218	A10_P2	T1
220	A11_P2	T2
222	A12_P2	U2
224	A13_P2	U3
226	A14_P2	V1
228	A15_P2	V2
230	$\overline{\text{CNTINT}}_P2$	R4
232	$\overline{\text{CNTRST}}_P2$	L3
234	$\overline{\text{MKLD}}_P2$	N3
236	$\overline{\text{CNTLD}}_P2$	N4
238	$\overline{\text{CNTINC}}_P2$	P4
240	$\overline{\text{CNTRD}}_P2$	T4
242	$\overline{\text{MKRD}}_P2$	T3
244	$\overline{\text{LB}}_P2$	Y1
246	$\overline{\text{UB}}_P2$	W2

**Table 7. Boundary Scan Order** (continued)

Cell #	Signal Name	Bump (Ball) ID
248	$\overline{\text{OE}}_P2$	U4
250	$\overline{\text{RW}}_P2$	V5
252	CE1_P2	V3
254	$\overline{\text{CE0}}_P2$	V4
256	$\overline{\text{INT}}_P2$	L2
258	CLK_P2	M4
260	A0_P1	K1
262	A1_P1	J2
264	A2_P1	J3
266	A3_P1	H1
268	A4_P1	H2
270	A5_P1	G2
272	A6_P1	G3
274	A7_P1	F1
276	A8_P1	F2
278	A9_P1	F3
280	A10_P1	E1
282	A11_P1	E2
284	A12_P1	D2
286	A13_P1	D3
288	A14_P1	C1
290	A15_P1	C2
292	$\overline{\text{CNTINT}}_P1$	F4
294	$\overline{\text{CNTRST}}_P1$	K3
296	$\overline{\text{MKLD}}_P1$	H3
298	$\overline{\text{CNTLD}}_P1$	H4
300	$\overline{\text{CNTINC}}_P1$	G4
302	$\overline{\text{CNTRD}}_P1$	E4
304	$\overline{\text{MKRD}}_P1$	E3
306	$\overline{\text{LB}}_P1$	A1
308	$\overline{\text{UB}}_P1$	B2
310	$\overline{\text{OE}}_P1$	D4
312	$\overline{\text{RW}}_P1$	C5
314	CE1_P1	C3
316	$\overline{\text{CE0}}_P1$	C4
318	$\overline{\text{INT}}_P1$	K2
320	CLK_P1	K4
322	IO9_P2	A6
324	IO10_P2	B6
326	IO11_P2	A5
328	IO12_P2	B5

**Table 7. Boundary Scan Order** (continued)

Cell #	Signal Name	Bump (Ball) ID
330	IO13_P2	A4
332	IO14_P2	B4
334	IO15_P2	A3
336	IO16_P2	B3
338	IO17_P2	A2
340	IO9_P1	C9
342	IO10_P1	A10
344	IO11_P1	B9
346	IO12_P1	A9
348	IO13_P1	B8
350	IO14_P1	A8
352	IO15_P1	C6
354	IO16_P1	A7
356	IO17_P1	B7
358	IO9_P3	A15
360	IO10_P3	B15
362	IO11_P3	A16
364	IO12_P3	B16
366	IO13_P3	A17
368	IO14_P3	B17
370	IO15_P3	A18
372	IO16_P3	B18
374	IO17_P3	A19
376	IO9_P4	C12
378	IO10_P4	A11
380	IO11_P4	B12
382	IO12_P4	A12
384	IO13_P4	B13
386	IO14_P4	A13
388	IO15_P4	C15
390	IO16_P4	A14
392	IO17_P4	B14

**Ordering Information**
**64K x 18 3.3V Synchronous QuadPort SRAM**

Speed (MHz)	Ordering Code	Package Name	Package Type	Operating Range
133	CY7C0430V-133BGC	BG272	272-Ball Grid Array (BGA)	Commercial
	CY7C0430V-133BGI	BG272	272-Ball Grid Array (BGA)	Industrial
100	CY7C0430V-100BGC	BG272	272-Ball Grid Array (BGA)	Commercial
	CY7C0430V-100BGI	BG272	272-Ball Grid Array (BGA)	Industrial

Document #: 38-00882-\*A

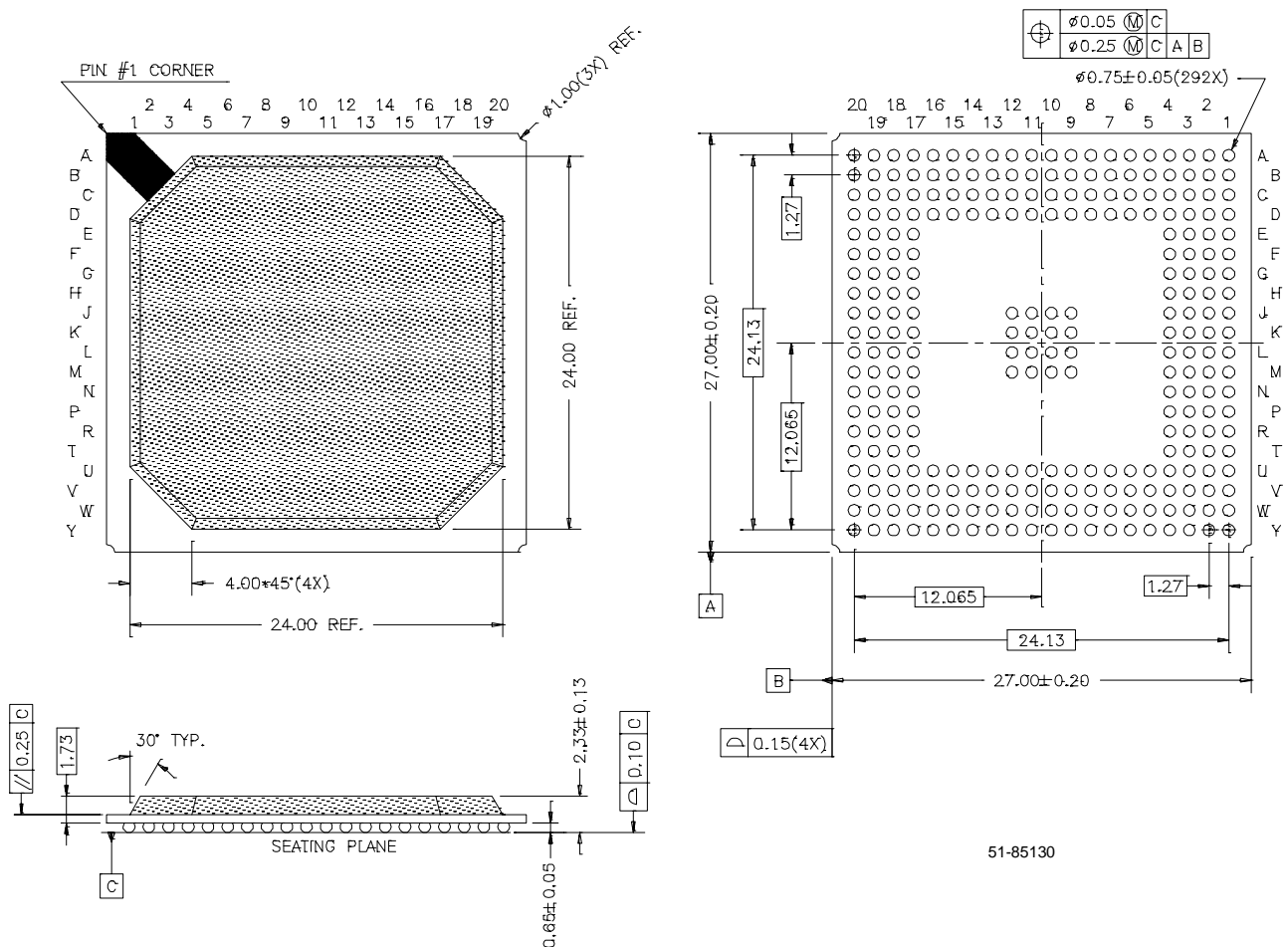
**Package Diagram**
**272-Lead Ball Grid Array (27 x 27 x 2.33 mm) BG272**

51-85130