



CY7C1305BV18
CY7C1307BV18

18-Mbit Burst of 4 Pipelined SRAM with QDR™ Architecture

Features

- **Separate independent Read and Write data ports**
 - Supports concurrent transactions
- **167-MHz Clock for high bandwidth**
 - 2.5 ns Clock-to-Valid access time
- **4-Word Burst for reducing the address bus frequency**
- **Double Data Rate (DDR) interfaces on both Read & Write Ports (data transferred at 333 MHz) @167 MHz**
- **Two input clocks (K and \bar{K}) for precise DDR timing**
 - SRAM uses rising edges only
- **Two input clocks for output data (C and \bar{C}) to minimize clock-skew and flight-time mismatches.**
- **Single multiplexed address input bus latches address inputs for both Read and Write ports**
- **Separate Port Selects for depth expansion**
- **Synchronous internally self-timed writes**
- **1.8V core power supply with HSTL Inputs and Outputs**
- **Available in 165-ball FBGA package (13 x 15 x 1.4 mm)**
- **Variable drive HSTL output buffers**
- **Expanded HSTL output voltage (1.4V–1.9V)**
- **JTAG Interface**

Configurations

CY7C1305BV18 – 1M x 18

CY7C1307BV18 – 512K x 36

Functional Description

The CY7C1305BV18/CY7C1307BV18 are 1.8V Synchronous Pipelined SRAMs equipped with QDR™ architecture. QDR architecture consists of two separate ports to access the memory array. The Read port has dedicated Data Outputs to support Read operations and the Write Port has dedicated Data Inputs to support Write operations. QDR architecture has separate data inputs and data outputs to completely eliminate the need to “turn-around” the data bus required with common I/O devices. Access to each port is accomplished through a common address bus. Addresses for Read and Write addresses are latched on alternate rising edges of the input (K) clock. Accesses to the device's Read and Write ports are completely independent of one another. In order to maximize data throughput, both Read and Write ports are equipped with Double Data Rate (DDR) interfaces. Each address location is associated with four 18-bit words (CY7C1305BV18) and four 36-bit words (CY7C1307BV18) that burst sequentially into or out of the device. Since data can be transferred into and out of the device on every rising edge of both input clocks (K/ \bar{K} and C/ \bar{C}) memory bandwidth is maximized while simplifying system design by eliminating bus “turn-arounds.”

Depth expansion is accomplished with Port Selects for each port. Port selects allow each port to operate independently.

All synchronous inputs pass through input registers controlled by the K or \bar{K} input clocks. All data outputs pass through output registers controlled by the C or \bar{C} input clocks. Writes are conducted with on-chip synchronous self-timed write circuitry.

Logic Block Diagram (CY7C1305BV18)

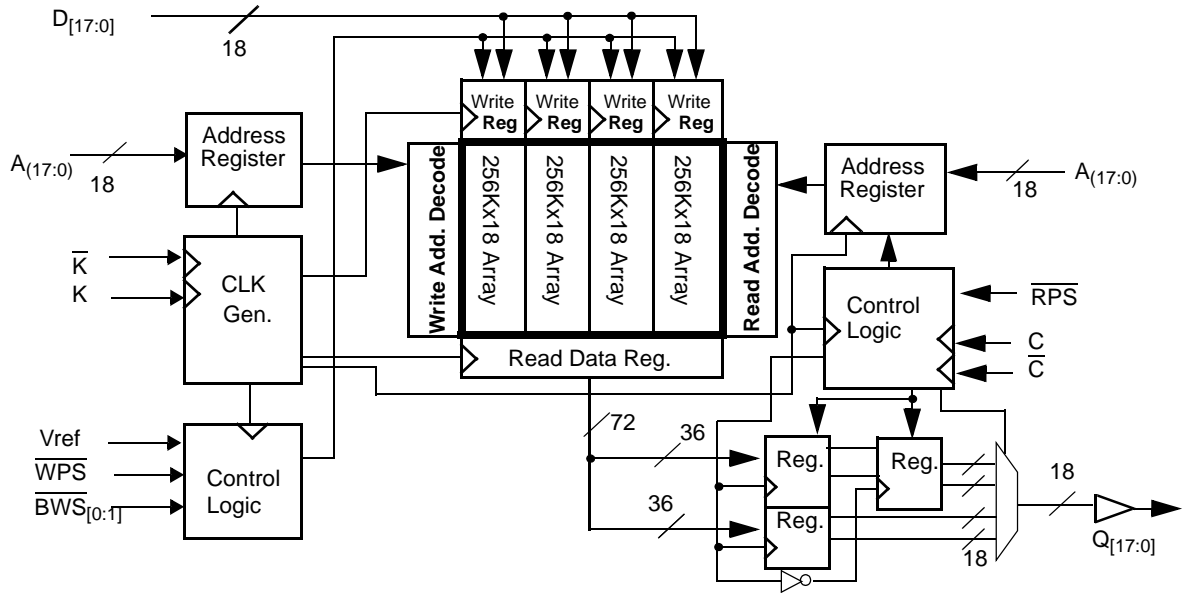

Logic Block Diagram (CY7C1307BV18)

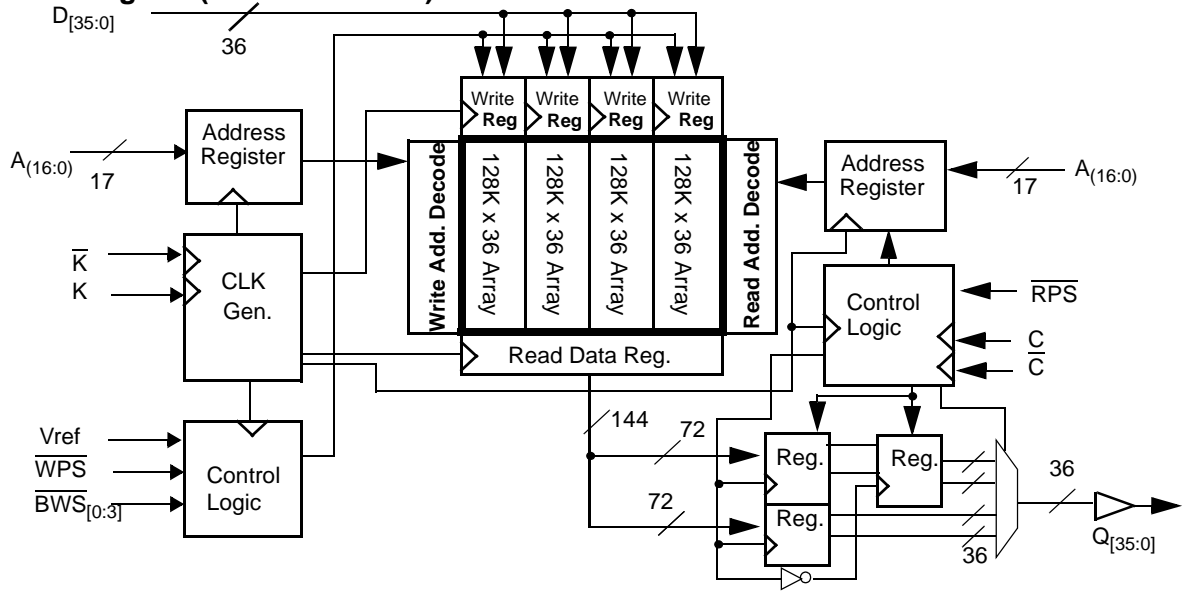

Pin Configuration

165-ball FBGA (13 x 15 x 1.4 mm) Pinout

CY7C1305BV18 (1M x 18)

	1	2	3	4	5	6	7	8	9	10	11
A	NC	Gnd/144M	NC/ 36M	WPS	BWS ₁	K	NC	RPS	A	Gnd/72M	NC
B	NC	Q9	D9	A	NC	K	BWS ₀	A	NC	NC	Q8
C	NC	NC	D10	VSS	A	NC	A	VSS	NC	Q7	D8
D	NC	D11	Q10	VSS	VSS	VSS	VSS	VSS	NC	NC	D7
E	NC	NC	Q11	VDDQ	VSS	VSS	VSS	VDDQ	NC	D6	Q6
F	NC	Q12	D12	VDDQ	VDD	VSS	VDD	VDDQ	NC	NC	Q5
G	NC	D13	Q13	VDDQ	VDD	VSS	VDD	VDDQ	NC	NC	D5
H	NC	VREF	VDDQ	VDDQ	VDD	VSS	VDD	VDDQ	VDDQ	VREF	ZQ
J	NC	NC	D14	VDDQ	VDD	VSS	VDD	VDDQ	NC	Q4	D4
K	NC	NC	Q14	VDDQ	VDD	VSS	VDD	VDDQ	NC	D3	Q3
L	NC	Q15	D15	VDDQ	VSS	VSS	VSS	VDDQ	NC	NC	Q2
M	NC	NC	D16	VSS	VSS	VSS	VSS	VSS	NC	Q1	D2
N	NC	D17	Q16	VSS	A	A	A	VSS	NC	NC	D1
P	NC	NC	Q17	A	A	C	A	A	NC	D0	Q0
R	TDO	TCK	A	A	A	C	A	A	A	TMS	TDI

CY7C1307BV18 (512K x 36)

	1	2	3	4	5	6	7	8	9	10	11
A	NC	Gnd/288M	NC/ 72M	WPS	BWS ₂	K	BWS ₁	RPS	NC/36M	Gnd/144M	NC
B	Q27	Q18	D18	A	BWS ₃	K	BWS ₀	A	D17	Q17	Q8
C	D27	Q28	D19	VSS	A	NC	A	VSS	D16	Q7	D8
D	D28	D20	Q19	VSS	VSS	VSS	VSS	VSS	Q16	D15	D7
E	Q29	D29	Q20	VDDQ	VSS	VSS	VSS	VDDQ	Q15	D6	Q6
F	Q30	Q21	D21	VDDQ	VDD	VSS	VDD	VDDQ	D14	Q14	Q5
G	D30	D22	Q22	VDDQ	VDD	VSS	VDD	VDDQ	Q13	D13	D5
H	NC	VREF	VDDQ	VDDQ	VDD	VSS	VDD	VDDQ	VDDQ	VREF	ZQ
J	D31	Q31	D23	VDDQ	VDD	VSS	VDD	VDDQ	D12	Q4	D4
K	Q32	D32	Q23	VDDQ	VDD	VSS	VDD	VDDQ	Q12	D3	Q3
L	Q33	Q24	D24	VDDQ	VSS	VSS	VSS	VDDQ	D11	Q11	Q2
M	D33	Q34	D25	VSS	VSS	VSS	VSS	VSS	D10	Q1	D2
N	D34	D26	Q25	VSS	A	A	A	VSS	Q10	D9	D1
P	Q35	D35	Q26	A	A	C	A	A	Q9	D0	Q0
R	TDO	TCK	A	A	A	C	A	A	A	TMS	TDI

Pin Definitions

Name	I/O	Description
$D_{[x:0]}$	Input-Synchronous	Data input signals, sampled on the rising edge of K and \bar{K} clocks during valid Write operations. CY7C1305BV18 – $D_{[17:0]}$ CY7C1307BV18 – $D_{[35:0]}$
WPS	Input-Synchronous	Write Port Select, active LOW. Sampled on the rising edge of the K clock. When asserted active, a Write operation is initiated. Deasserting will deselect the Write port. Deselecting the Write port will cause $D_{[x:0]}$ to be ignored.
$\overline{BWS}_0, \overline{BWS}_1, \overline{BWS}_2, \overline{BWS}_3$	Input-Synchronous	Byte Write Select 0, 1, 2, and 3 - active LOW. Sampled on the rising edge of the K and \bar{K} clocks during Write operations. Used to select which byte is written into the device during the current portion of the write operations. Bytes not written remain unaltered. CY7C1305BV18 - \overline{BWS}_0 controls $D_{[8:0]}$ and \overline{BWS}_1 controls $D_{[17:9]}$ CY7C1307BV18 - \overline{BWS}_0 controls $D_{[8:0]}$, \overline{BWS}_1 controls $D_{[17:9]}$, \overline{BWS}_2 controls $D_{[26:18]}$ and \overline{BWS}_3 controls $D_{[35:27]}$ All the Byte Write Selects are sampled on the same edge as the data. Deselecting a Byte Write Select will cause the corresponding byte of data to be ignored and not written into the device.
A	Input-Synchronous	Address Inputs. Sampled on the rising edge of the K clock during active Read and Write operations. These address inputs are multiplexed for both Read and Write operations. Internally, the device is organized as 1M x 18 (4 arrays each of 256K x 18) for CY7C1305BV18 and 512K x 36 (4 arrays each of 128K x 36) for CY7C1307BV18. Therefore, only 18 address inputs for CY7C1305BV18 and 17 address inputs for CY7C1307BV18. These inputs are ignored when the appropriate port is deselected.
$Q_{[x:0]}$	Outputs-Synchronous	Data Output signals. These pins drive out the requested data during a Read operation. Valid data is driven out on the rising edge of both the C and \bar{C} clocks during Read operations or K and \bar{K} when in single clock mode. When the Read port is deselected, $Q_{[x:0]}$ are automatically three-stated. CY7C1305BV18 - $Q_{[17:0]}$ CY7C1307BV18 - $Q_{[35:0]}$
RPS	Input-Synchronous	Read Port Select, active LOW. Sampled on the rising edge of Positive Input Clock (K). When active, a Read operation is initiated. Deasserting will cause the Read port to be deselected. When deselected, the pending access is allowed to complete and the output drivers are automatically three-stated following the next rising edge of the C clock. Each read access consists of a burst of four sequential 18-bit or 36-bit transfers.
C	Input-Clock	Positive Input Clock for Output Data. C is used in conjunction with \bar{C} to clock out the Read data from the device. C and \bar{C} can be used together to deskew the flight times of various devices on the board back to the controller. See application example for further details.
\bar{C}	Input-Clock	Negative Input Clock for Output Data. \bar{C} is used in conjunction with C to clock out the Read data from the device. C and \bar{C} can be used together to deskew the flight times of various devices on the board back to the controller. See application example for further details.
K	Input-Clock	Positive Input Clock Input. The rising edge of K is used to capture synchronous inputs to the device and to drive out data through $Q_{[x:0]}$ when in single clock mode. All accesses are initiated on the rising edge of K.
\bar{K}	Input-Clock	Negative Input Clock Input. \bar{K} is used to capture synchronous inputs to the device and to drive out data through $Q_{[x:0]}$ when in single clock mode.
ZQ	Input	Output Impedance Matching Input. This input is used to tune the device outputs to the system data bus impedance. $Q_{[x:0]}$ output impedance are set to $0.2 \times RQ$, where RQ is a resistor connected between ZQ and ground. Alternately, this pin can be connected directly to V_{DDQ} , which enables the minimum impedance mode. This pin cannot be connected directly to GND or left unconnected.
TDO	Output	TDO pin for JTAG.
TCK	Input	TCK pin for JTAG.
TDI	Input	TDI pin for JTAG.
TMS	Input	TMS pin for JTAG.
NC/36M	N/A	Address expansion for 36M. This is not connected to the die. Can be connected to any voltage level on CY7C1305BV18/CY7C1307BV18.

Pin Definitions (continued)

Name	I/O	Description
GND/72M	Input	Address expansion for 72M. This should be tied LOW on the CY7C1305BV18
NC/72M	N/A	Address expansion for 72M. This can be connected to any voltage level on CY7C1307BV18
GND/144M	Input	Address expansion for 144M. This should be tied LOW on CY7C1305BV18/CY7C1307BV18.
GND/288M	Input	Address expansion for 144M. This should be tied LOW on CY7C1307BV18.
V _{REF}	Input-Reference	Reference Voltage Input. Static input used to set the reference level for HSTL inputs and Outputs as well as AC measurement points.
V _{DD}	Power Supply	Power supply inputs to the core of the device.
V _{SS}	Ground	Ground for the device.
V _{DDQ}	Power Supply	Power supply inputs for the outputs of the device.
NC	N/A	Not connected to the die. Can be tied to any voltage level.

Introduction

Functional Overview

The CY7C1305BV18/CY7C1307BV18 are synchronous pipelined Burst SRAMs equipped with both a Read port and a Write port. The Read port is dedicated to Read operations and the Write port is dedicated to Write operations. Data flows into the SRAM through the Write port and out through the Read port. These devices multiplex the address inputs in order to minimize the number of address pins required. By having separate Read and Write ports, the device completely eliminates the need to “turn-around” the data bus and avoids any possible data contention, thereby simplifying system design. Each access consists of four 18-bit data transfers in the case of CY7C1305BV18 and four 36-bit data transfers in the case of CY7C1307BV18, in two clock cycles.

Accesses for both ports are initiated on the rising edge of the positive input clock (K). All synchronous input timing is referenced from the rising edge of the input clocks (K and \bar{K}) and all output timing is referenced to the rising edge of output clocks (C and \bar{C} , or K and \bar{K} when in single clock mode).

All synchronous data inputs ($D_{[x:0]}$) pass through input registers controlled by the rising edge of input clocks (K and \bar{K}). All synchronous data outputs ($Q_{[x:0]}$) pass through output registers controlled by the rising edge of the output clocks (C and \bar{C} , or K and \bar{K} when in single clock mode).

All synchronous control (\overline{RPS} , \overline{WPS} , $\overline{BWS}_{[0:x]}$) inputs pass through input registers controlled by the rising edge of input clocks (K and \bar{K}).

CY7C1305BV18 is described in the following sections. The same basic descriptions apply to CY7C1307BV18.

Read Operations

The CY7C1305BV18 is organized internally as four arrays of 256K x 18. Accesses are completed in a burst of four sequential 18-bit data words. Read operations are initiated by asserting \overline{RPS} active at the rising edge of the positive input clock (K). The address presented to Address inputs are stored in the Read address register. Following the next K clock rise the corresponding lowest order 18-bit word of data is driven onto the $Q_{[17:0]}$ using C as the output timing reference. On the subsequent rising edge of \bar{C} the next 18-bit data word is driven onto the $Q_{[17:0]}$. This process continues until all four 18-bit data words have been driven out onto $Q_{[17:0]}$. The requested data

will be valid 2.5 ns from the rising edge of the output clock (C and \bar{C} , or K and \bar{K} when in single clock mode, 250-MHz device). In order to maintain the internal logic, each read access must be allowed to complete. Each Read access consists of four 18-bit data words and takes two clock cycles to complete. Therefore, Read accesses to the device can not be initiated on two consecutive K clock rises. The internal logic of the device will ignore the second Read request. Read accesses can be initiated on every other K clock rise. Doing so will pipeline the data flow such that data is transferred out of the device on every rising edge of the output clocks (C and \bar{C} , or K and \bar{K} when in single clock mode).

When the read port is deselected, the CY7C1305BV18 will first complete the pending read transactions. Synchronous internal circuitry will automatically three-state the outputs following the next rising edge of the positive output clock (C). This will allow for a seamless transition between devices without the insertion of wait states in a depth expanded memory.

Write Operations

Write operations are initiated by asserting \overline{WPS} active at the rising edge of the positive input clock (K). On the following K clock rise the data presented to $D_{[17:0]}$ is latched and stored into the lower 18-bit Write Data register provided $\overline{BWS}_{[1:0]}$ are both asserted active. On the subsequent rising edge of the negative input clock (\bar{K}) the information presented to $D_{[17:0]}$ is also stored into the Write Data register provided $\overline{BWS}_{[1:0]}$ are both asserted active. This process continues for one more cycle until four 18-bit words (a total of 72 bits) of data are stored in the SRAM. The 72 bits of data are then written into the memory array at the specified location. Therefore, Write accesses to the device can not be initiated on two consecutive K clock rises. The internal logic of the device will ignore the second Write request. Write accesses can be initiated on every other rising edge of the positive clock (K). Doing so will pipeline the data flow such that 18-bits of data can be transferred into the device on every rising edge of the input clocks (K and \bar{K}).

When deselected, the Write port will ignore all inputs after the pending Write operations have been completed.

Byte Write Operations

Byte Write operations are supported by the CY7C1305BV18. A write operation is initiated as described in the Write Operation section above. The bytes that are written are deter-

mined by \overline{BWS}_0 and \overline{BWS}_1 which are sampled with each set of 18-bit data word. Asserting the appropriate Byte Write Select input during the data portion of a write will allow the data being presented to be latched and written into the device. De-asserting the Byte Write Select input during the data portion of a write will allow the data stored in the device for that byte to remain unaltered. This feature can be used to simplify Read/Modify/Write operations to a Byte Write operation.

Single Clock Mode

The CY7C1305BV18 can be used with a single clock that controls both the input and output registers. In this mode the device will recognize only a single pair of input clocks (K and \overline{K}) that control both the input and output registers. This operation is identical to the operation if the device had zero skew between the K/ \overline{K} and C/ \overline{C} clocks. All timing parameters remain the same in this mode. To use this mode of operation, the user must tie C and \overline{C} HIGH at power-on. This function is a strap option and not alterable during device operation.

Concurrent Transactions

The Read and Write ports on the CY7C1305BV18 operate completely independently of one another. Since each port latches the address inputs on different clock edges, the user can Read or Write to any location, regardless of the transaction on the other port. If the ports access the same location at the same time, the SRAM will deliver the most recent information associated with the specified address location. This includes forwarding data from a Write cycle that was initiated on the previous K clock rise.

Read and Write accesses must be scheduled such that one transaction is initiated on any clock cycle. If both ports are

selected on the same K clock rise, the arbitration depends on the previous state of the SRAM. If both ports were deselected, the Read port will take priority. If a Read was initiated on the previous cycle, the Write port will assume priority (since Read operations can not be initiated on consecutive cycles). If a Write was initiated on the previous cycle, the Read port will assume priority (since Write operations can not be initiated on consecutive cycles). Therefore, asserting both port selects active from a deselected state will result in alternating Read/Write operations being initiated, with the first access being a Read.

Depth Expansion

The CY7C1305BV18 has a Port Select input for each port. This allows for easy depth expansion. Both Port Selects are sampled on the rising edge of the positive input clock only (K). Each port select input can deselect the specified port. Deselecting a port will not affect the other port. All pending transactions (Read and Write) will be completed prior to the device being deselected.

Programmable Impedance

An external resistor, RQ, must be connected between the ZQ pin on the SRAM and V_{SS} to allow the SRAM to adjust its output driver impedance. The value of RQ must be 5X the value of the intended line impedance driven by the SRAM. The allowable range of RQ to guarantee impedance matching with a tolerance of $\pm 15\%$ is between 175Ω and 350Ω , with $V_{DDQ} = 1.5V$. The output impedance is adjusted every 1024 cycles upon power-up to account for drifts in supply voltage and temperature.

Application Example^[1]

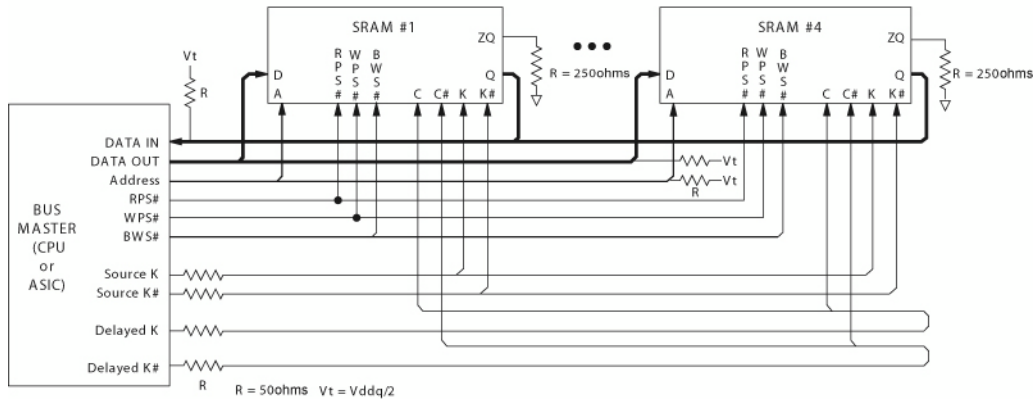

Truth Table^[2, 3, 4, 5, 6, 7, 8, 9]

Operation	K	RPS	WPS	DQ	DQ	DQ	DQ
Write Cycle: Load address on the rising edge of K; wait one cycle; input write data on two consecutive K and K rising edges.	L-H	H ^[8]	L ^[9]	D(A+00) at K(t+1) ↑	D(A+01) at K(t+1) ↑	D(A+10) at K(t+2) ↑	D(A+11) at K(t+2) ↑
Read Cycle: Load address on the rising edge of K; wait one cycle; read data on two consecutive C and C rising edges.	L-H	L ^[9]	X	Q(A+00) at C(t+1) ↑	Q(A+01) at C(t+1) ↑	Q(A+10) at C(t+2) ↑	Q(A+11) at C(t+2) ↑
NOP: No operation	L-H	H	H	D = X Q = High-Z	D = X Q = High-Z	D = X Q = High-Z	D = X Q = High-Z
Standby: Clock stopped	Stopped	X	X	Previous state	Previous state	Previous state	Previous state

Write Cycle Descriptions (CY7C1305BV18)^[2,10]

BWS ₀	BWS ₁	K	K	Comments
L	L	L-H	-	During the Data portion of a Write sequence, both bytes (D _[17:0]) are written into the device.
L	L	-	L-H	During the Data portion of a Write sequence, both bytes (D _[17:0]) are written into the device.
L	H	L-H	-	During the Data portion of a Write sequence, only the lower byte (D _[8:0]) is written into the device. D _[17:9] will remain unaltered.
L	H	-	L-H	During the Data portion of a Write sequence, only the lower byte (D _[8:0]) is written into the device. D _[17:9] will remain unaltered.
H	L	L-H	-	During the Data portion of a Write sequence, only the upper byte (D _[17:9]) is written into the device. D _[8:0] will remain unaltered.
H	L	-	L-H	During the Data portion of a Write sequence, only the upper byte (D _[17:9]) is written into the device. D _[8:0] will remain unaltered.
H	H	L-H	-	No data is written into the device during this portion of a Write operation.
H	H	-	L-H	No data is written into the device during this portion of a Write operation.

Notes:

- The above application shows four QDR-I being used.
- X = Don't Care, H = Logic HIGH, L = Logic LOW, ↑ represents rising edge.
- Device will power-up deselected and the outputs in a three-state condition.
- "A" represents address location latched by the devices when transaction was initiated. A+00, A+01, A+10 and A+11 represents the address sequence in the burst.
- "t" represents the cycle at which a Read/Write operation is started. t+1 and t+2 are the first and second clock cycles respectively succeeding the "t" clock cycle.
- Data inputs are registered at K and K rising edges. Data outputs are delivered on C and C rising edges, except when in single clock mode.
- It is recommended that K = K and C = C when clock is stopped. This is not essential, but permits most rapid restart by overcoming transmission line charging symmetrically.
- If this signal was LOW to initiate the previous cycle, this signal becomes a don't care for this operation.
- This signal was HIGH on previous K clock rise. Initiating consecutive Read or Write operations on consecutive K clock rises is not permitted. The device will ignore the second Read request.
- Assumes a Write cycle was initiated per the Write Port Cycle Description Truth Table. BWS₀ and BWS₁ in the case of CY7C1305BV18 and BWS₂ and BWS₃ in the case of CY7C1307BV18 can be altered on different portions of a Write cycle, as long as the set-up and hold requirements are achieved.

Write Cycle Descriptions (CY7C1307BV18)^[2,10]

\overline{BWS}_0	\overline{BWS}_1	\overline{BWS}_2	\overline{BWS}_3	K	\overline{K}	Comments
L	L	L	L	L-H	-	During the Data portion of a Write sequence, all four bytes ($D_{[35:0]}$) are written into the device.
L	L	L	L	-	L-H	During the Data portion of a Write sequence, all four bytes ($D_{[35:0]}$) are written into the device.
L	H	H	H	L-H	-	During the Data portion of a Write sequence, only the lower byte ($D_{[8:0]}$) is written into the device. $D_{[35:9]}$ will remain unaltered.
L	H	H	H	-	L-H	During the Data portion of a Write sequence, only the lower byte ($D_{[8:0]}$) is written into the device. $D_{[35:9]}$ will remain unaltered.
H	L	H	H	L-H	-	During the Data portion of a Write sequence, only the byte ($D_{[17:9]}$) is written into the device. $D_{[8:0]}$ and $D_{[35:18]}$ will remain unaltered.
H	L	H	H	-	L-H	During the Data portion of a Write sequence, only the byte ($D_{[17:9]}$) is written into the device. $D_{[8:0]}$ and $D_{[35:18]}$ will remain unaltered.
H	H	L	H	L-H	-	During the Data portion of a Write sequence, only the byte ($D_{[26:18]}$) is written into the device. $D_{[17:0]}$ and $D_{[35:27]}$ will remain unaltered.
H	H	L	H	-	L-H	During the Data portion of a Write sequence, only the byte ($D_{[26:18]}$) is written into the device. $D_{[17:0]}$ and $D_{[35:27]}$ will remain unaltered.
H	H	H	L	L-H		During the Data portion of a Write sequence, only the byte ($D_{[35:27]}$) is written into the device. $D_{[26:0]}$ will remain unaltered.
H	H	H	L	-	L-H	During the Data portion of a Write sequence, only the byte ($D_{[35:27]}$) is written into the device. $D_{[26:0]}$ will remain unaltered.
H	H	H	H	L-H	-	No data is written into the device during this portion of a Write operation.
H	H	H	H	-	L-H	No data is written into the device during this portion of a Write operation.

IEEE 1149.1 Serial Boundary Scan (JTAG)

These SRAMs incorporate a serial boundary scan test access port (TAP) in the FBGA package. This part is fully compliant with IEEE Standard #1149.1-1900. The TAP operates using JEDEC standard 1.8V I/O logic levels.

Disabling the JTAG Feature

It is possible to operate the SRAM without using the JTAG feature. To disable the TAP controller, TCK must be tied LOW (V_{SS}) to prevent clocking of the device. TDI and TMS are internally pulled up and may be unconnected. They may alternately be connected to V_{DD} through a pull-up resistor. TDO should be left unconnected. Upon power-up, the device will come up in a reset state which will not interfere with the operation of the device.

Test Access Port—Test Clock

The test clock is used only with the TAP controller. All inputs are captured on the rising edge of TCK. All outputs are driven from the falling edge of TCK.

Test Mode Select

The TMS input is used to give commands to the TAP controller and is sampled on the rising edge of TCK. It is allowable to leave this pin unconnected if the TAP is not used. The pin is pulled up internally, resulting in a logic HIGH level.

Test Data-In (TDI)

The TDI pin is used to serially input information into the registers and can be connected to the input of any of the registers. The register between TDI and TDO is chosen by the instruction that is loaded into the TAP instruction register. For information on loading the instruction register, see the TAP Controller State Diagram. TDI is internally pulled up and can be unconnected if the TAP is unused in an application. TDI is connected to the most significant bit (MSB) on any register.

Test Data-Out (TDO)

The TDO output pin is used to serially clock data-out from the registers. The output is active depending upon the current state of the TAP state machine (see Instruction codes). The output changes on the falling edge of TCK. TDO is connected to the least significant bit (LSB) of any register.

Performing a TAP Reset

A Reset is performed by forcing TMS HIGH (V_{DD}) for five rising edges of TCK. This RESET does not affect the operation of the SRAM and may be performed while the SRAM is operating. At power-up, the TAP is reset internally to ensure that TDO comes up in a high-Z state.

TAP Registers

Registers are connected between the TDI and TDO pins and allow data to be scanned into and out of the SRAM test circuitry. Only one register can be selected at a time through the instruction registers. Data is serially loaded into the TDI pin on the rising edge of TCK. Data is output on the TDO pin on the falling edge of TCK.

Instruction Register

Three-bit instructions can be serially loaded into the instruction register. This register is loaded when it is placed between the

TDI and TDO pins as shown in TAP Controller Block Diagram. Upon power-up, the instruction register is loaded with the IDCODE instruction. It is also loaded with the IDCODE instruction if the controller is placed in a reset state as described in the previous section.

When the TAP controller is in the Capture IR state, the two least significant bits are loaded with a binary “01” pattern to allow for fault isolation of the board level serial test path.

Bypass Register

To save time when serially shifting data through registers, it is sometimes advantageous to skip certain chips. The bypass register is a single-bit register that can be placed between TDI and TDO pins. This allows data to be shifted through the SRAM with minimal delay. The bypass register is set LOW (V_{SS}) when the BYPASS instruction is executed.

Boundary Scan Register

The boundary scan register is connected to all of the input and output pins on the SRAM. Several no connect (NC) pins are also included in the scan register to reserve pins for higher density devices.

The boundary scan register is loaded with the contents of the RAM Input and Output ring when the TAP controller is in the Capture-DR state and is then placed between the TDI and TDO pins when the controller is moved to the Shift-DR state. The EXTEST, SAMPLE/PRELOAD and SAMPLE Z instructions can be used to capture the contents of the Input and Output ring.

The Boundary Scan Order tables show the order in which the bits are connected. Each bit corresponds to one of the bumps on the SRAM package. The MSB of the register is connected to TDI, and the LSB is connected to TDO.

Identification (ID) Register

The ID register is loaded with a vendor-specific, 32-bit code during the Capture-DR state when the IDCODE command is loaded in the instruction register. The IDCODE is hardwired into the SRAM and can be shifted out when the TAP controller is in the Shift-DR state. The ID register has a vendor code and other information described in the Identification Register Definitions table.

TAP Instruction Set

Eight different instructions are possible with the three-bit instruction register. All combinations are listed in the Instruction Code table. Three of these instructions are listed as RESERVED and should not be used. The other five instructions are described in detail below.

Instructions are loaded into the TAP controller during the Shift-IR state when the instruction register is placed between TDI and TDO. During this state, instructions are shifted through the instruction register through the TDI and TDO pins. To execute the instruction once it is shifted in, the TAP controller needs to be moved into the Update-IR state.

IDCODE

The IDCODE instruction causes a vendor-specific, 32-bit code to be loaded into the instruction register. It also places the instruction register between the TDI and TDO pins and allows the IDCODE to be shifted out of the device when the TAP controller enters the Shift-DR state. The IDCODE instruction

is loaded into the instruction register upon power-up or whenever the TAP controller is given a test logic reset state.

SAMPLE Z

The SAMPLE Z instruction causes the boundary scan register to be connected between the TDI and TDO pins when the TAP controller is in a Shift-DR state. The SAMPLE Z command puts the output bus into a High-Z state until the next command is given during the “Update IR” state.

SAMPLE/PRELOAD

SAMPLE/PRELOAD is a 1149.1 mandatory instruction. When the SAMPLE/PRELOAD instructions are loaded into the instruction register and the TAP controller is in the Capture-DR state, a snapshot of data on the inputs and output pins is captured in the boundary scan register.

The user must be aware that the TAP controller clock can only operate at a frequency up to 10 MHz, while the SRAM clock operates more than an order of magnitude faster. Because there is a large difference in the clock frequencies, it is possible that during the Capture-DR state, an input or output will undergo a transition. The TAP may then try to capture a signal while in transition (metastable state). This will not harm the device, but there is no guarantee as to the value that will be captured. Repeatable results may not be possible.

To guarantee that the boundary scan register will capture the correct value of a signal, the SRAM signal must be stabilized long enough to meet the TAP controller's capture set-up plus hold times (t_{CS} and t_{CH}). The SRAM clock input might not be captured correctly if there is no way in a design to stop (or slow) the clock during a SAMPLE/PRELOAD instruction. If this is an issue, it is still possible to capture all other signals and simply ignore the value of the CK and \overline{CK} captured in the boundary scan register.

Once the data is captured, it is possible to shift out the data by putting the TAP into the Shift-DR state. This places the boundary scan register between the TDI and TDO pins.

PRELOAD allows an initial data pattern to be placed at the latched parallel outputs of the boundary scan register cells prior to the selection of another boundary scan test operation.

The shifting of data for the SAMPLE and PRELOAD phases can occur concurrently when required—that is, while data captured is shifted out, the preloaded data can be shifted in.

BYPASS

When the BYPASS instruction is loaded in the instruction register and the TAP is placed in a Shift-DR state, the bypass register is placed between the TDI and TDO pins. The advantage of the BYPASS instruction is that it shortens the boundary scan path when multiple devices are connected together on a board.

EXTEST

The EXTEST instruction enables the preloaded data to be driven out through the system output pins. This instruction also selects the boundary scan register to be connected for serial access between the TDI and TDO in the shift-DR controller state.

EXTEST Output Bus Tri-State

IEEE Standard 1149.1 mandates that the TAP controller be able to put the output bus into a tri-state mode.

The boundary scan register has a special bit located at bit #47. When this scan cell, called the “extest output bus tri-state”, is latched into the preload register during the “Update-DR” state in the TAP controller, it will directly control the state of the output (Q-bus) pins, when the EXTEST is entered as the current instruction. When HIGH, it will enable the output buffers to drive the output bus. When LOW, this bit will place the output bus into a High-Z condition.

This bit can be set by entering the SAMPLE/PRELOAD or EXTEST command, and then shifting the desired bit into that cell, during the “Shift-DR” state. During “Update-DR”, the value loaded into that shift-register cell will latch into the preload register. When the EXTEST instruction is entered, this bit will directly control the output Q-bus pins. Note that this bit is pre-set HIGH to enable the output when the device is powered-up, and also when the TAP controller is in the “Test-Logic-Reset” state.

Reserved

These instructions are not implemented but are reserved for future use. Do not use these instructions.

TAP Controller State Diagram^[11]

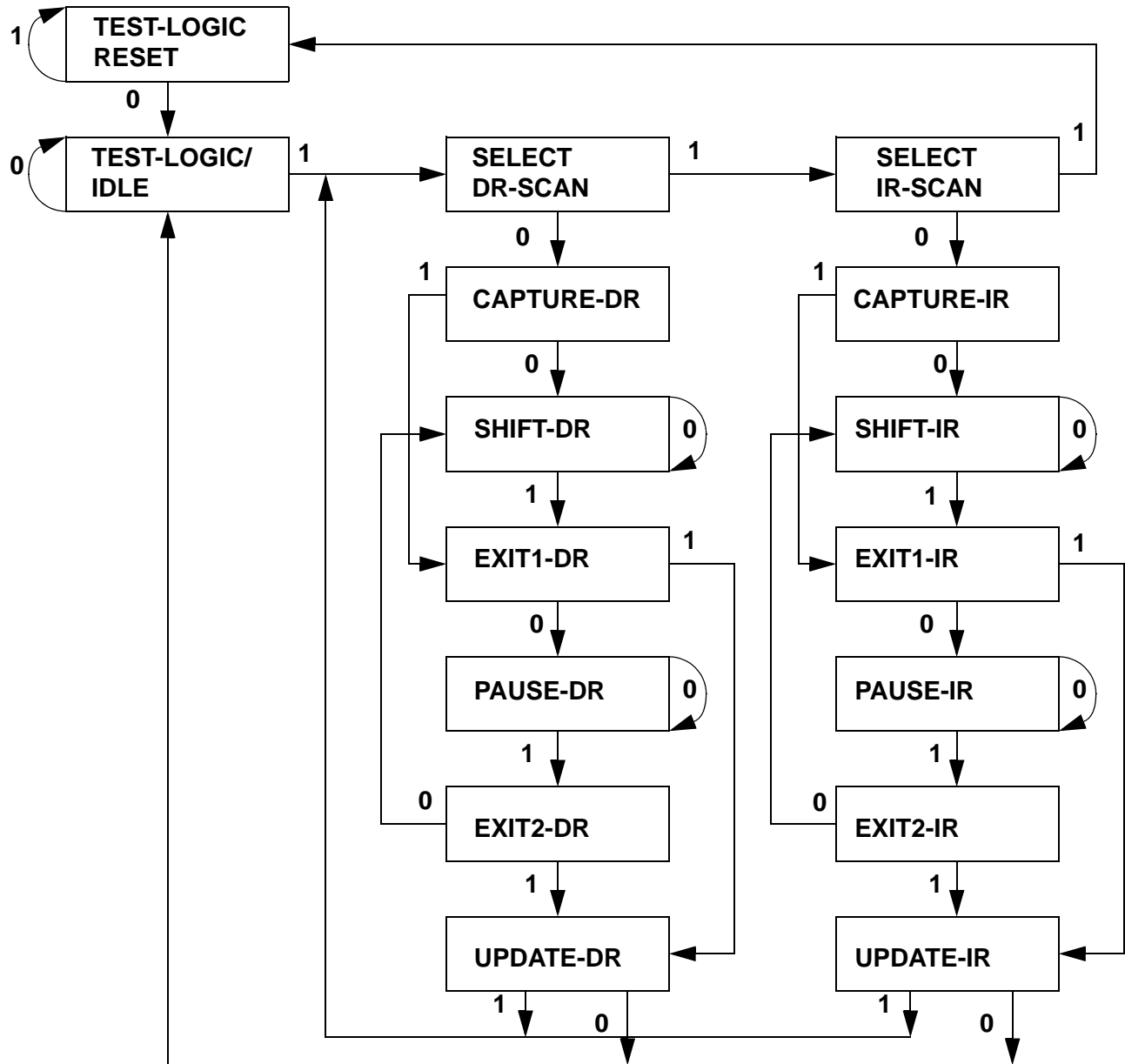

Note:
11. The 0/1 next to each state represents the value at TMS at the rising edge of TCK.

TAP Controller Block Diagram

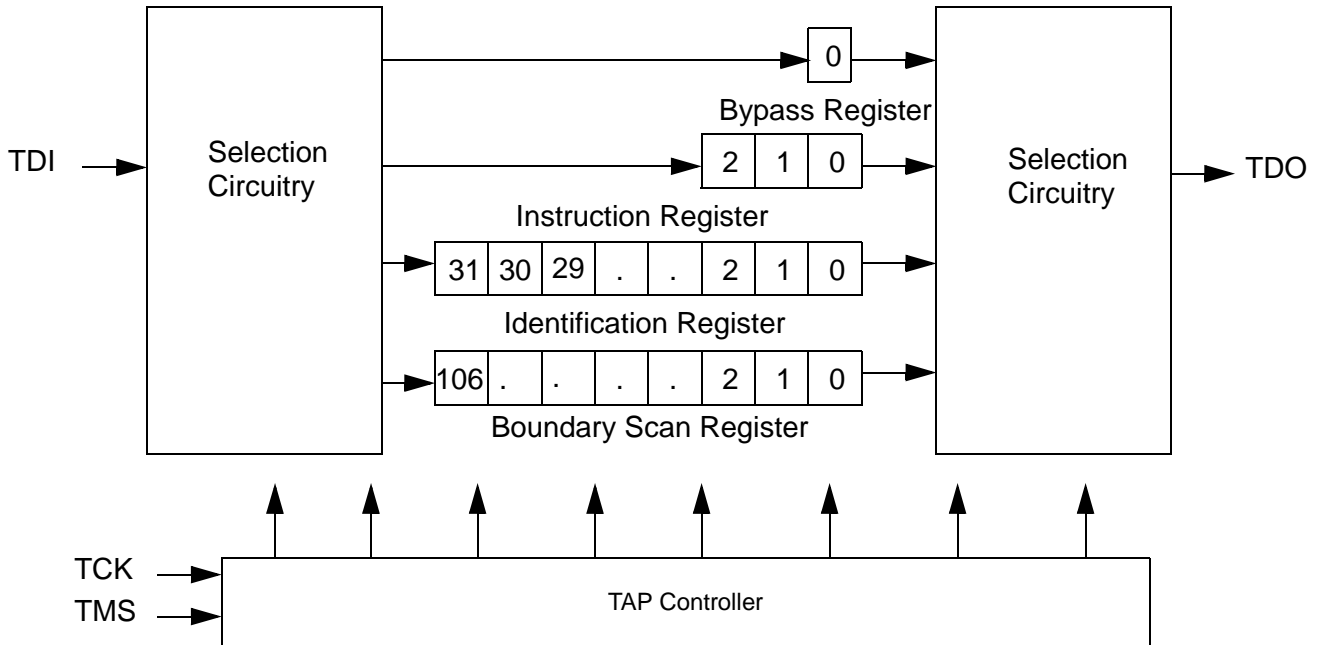

TAP Electrical Characteristics Over the Operating Range [12, 15, 17]

Parameter	Description	Test Conditions	Min.	Max.	Unit
V _{OH1}	Output HIGH Voltage	I _{OH} = -2.0 mA	1.4		V
V _{OH2}	Output HIGH Voltage	I _{OH} = -100 μA	1.6		V
V _{OL1}	Output LOW Voltage	I _{OL} = 2.0 mA		0.4	V
V _{OL2}	Output LOW Voltage	I _{OL} = 100 μA		0.2	V
V _{IH}	Input HIGH Voltage		0.65V _{DD}	V _{DD} + 0.3	V
V _{IL}	Input LOW Voltage		-0.3	0.35V _{DD}	V
I _X	Input and Output Load Current	GND ≤ V _I ≤ V _{DDQ}	-5	5	μA

TAP AC Switching Characteristics Over the Operating Range [13, 14]

Parameter	Description	Min.	Max.	Unit
t _{TCYC}	TCK Clock Cycle Time	50		ns
t _{TF}	TCK Clock Frequency		20	MHz
t _{TH}	TCK Clock HIGH	20		ns
t _{TL}	TCK Clock LOW	20		ns
Set-up Times				
t _{TMSS}	TMS Set-up to TCK Clock Rise	10		ns
t _{TDIS}	TDI Set-up to TCK Clock Rise	10		ns
t _{CS}	Capture Set-up to TCK Rise	10		ns
Hold Times				
t _{TMSH}	TMS Hold after TCK Clock Rise	10		ns
t _{TDIH}	TDI Hold after Clock Rise	10		ns
t _{CH}	Capture Hold after Clock Rise	10		ns

Notes:

12. These characteristics pertain to the TAP inputs (TMS, TCK, TDI and TDO). Parallel load levels are specified in the Electrical Characteristics Table.

13. Parameters t_{CS} and t_{CH} refer to the set-up and hold time requirements of latching data from the boundary scan register.

14. Test conditions are specified using the load in TAP AC Test Conditions. t_R/t_F = 1 ns.

TAP AC Switching Characteristics Over the Operating Range (continued)^[13, 14]

Parameter	Description	Min.	Max.	Unit
Output Times				
t_{TDOV}	TCK Clock LOW to TDO Valid		20	ns
t_{TDOX}	TCK Clock LOW to TDO Invalid	0		ns

TAP Timing and Test Conditions^[12]

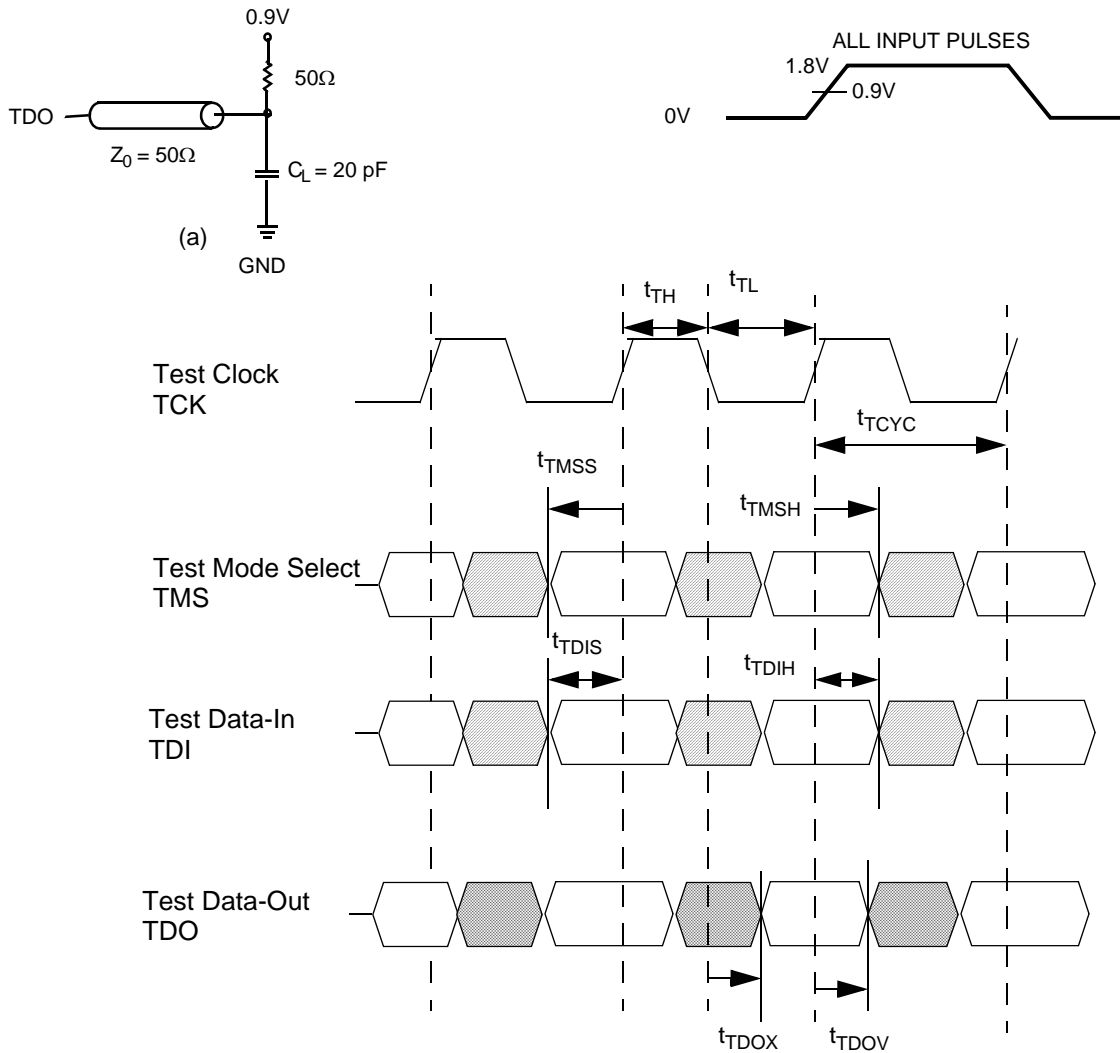

Identification Register Definitions

Instruction Field	Value		Description
	CY7C1305BV18	CY7C1307BV18	
Revision Number (31:29)	000	000	Version number.
Cypress Device ID (28:12)	11010010011010101	11010010011100101	Defines the type of SRAM.
Cypress JEDEC ID (11:1)	00000110100	00000110100	Allows unique identification of SRAM vendor.
ID Register Presence (0)	1	1	Indicate the presence of an ID register.

Scan Register Sizes

Register Name	Bit Size
Instruction	3
Bypass	1
ID	32
Boundary Scan	107

Instruction Codes

Instruction	Code	Description
EXTEST	000	Captures the Input/Output ring contents.
IDCODE	001	Loads the ID register with the vendor ID code and places the register between TDI and TDO. This operation does not affect SRAM operation.
SAMPLE Z	010	Captures the Input/Output contents. Places the boundary scan register between TDI and TDO. Forces all SRAM output drivers to a High-Z state.
RESERVED	011	Do Not Use: This instruction is reserved for future use.
SAMPLE/PRELOAD	100	Captures the Input/Output ring contents. Places the boundary scan register between TDI and TDO. Does not affect the SRAM operation.
RESERVED	101	Do Not Use: This instruction is reserved for future use.
RESERVED	110	Do Not Use: This instruction is reserved for future use.
BYPASS	111	Places the bypass register between TDI and TDO. This operation does not affect SRAM operation.

Boundary Scan Order

Bit #	Bump ID
0	6R
1	6P
2	6N
3	7P
4	7N
5	7R
6	8R
7	8P
8	9R
9	11P
10	10P
11	10N
12	9P
13	10M
14	11N
15	9M
16	9N
17	11L
18	11M
19	9L
20	10L
21	11K
22	10K
23	9J
24	9K
25	10J
26	11J

Bit #	Bump ID
27	11H
28	10G
29	9G
30	11F
31	11G
32	9F
33	10F
34	11E
35	10E
36	10D
37	9E
38	10C
39	11D
40	9C
41	9D
42	11B
43	11C
44	9B
45	10B
46	11A
47	Internal
48	9A
49	8B
50	7C
51	6C
52	8A
53	7A

Bit #	Bump ID
54	7B
55	6B
56	6A
57	5B
58	5A
59	4A
60	5C
61	4B
62	3A
63	1H
64	1A
65	2B
66	3B
67	1C
68	1B
69	3D
70	3C
71	1D
72	2C
73	3E
74	2D
75	2E
76	1E
77	2F
78	3F
79	1G
80	1F

Bit #	Bump ID
81	3G
82	2G
83	1J
84	2J
85	3K
86	3J
87	2K
88	1K
89	2L
90	3L
91	1M
92	1L
93	3N
94	3M
95	1N
96	2M
97	3P
98	2N
99	2P
100	1P
101	3R
102	4R
103	4P
104	5P
105	5N
106	5R

Maximum Ratings

(Above which the useful life may be impaired.)

Storage Temperature	-65°C to +150°C
Ambient Temperature with Power Applied	-55°C to +125°C
Supply Voltage on V _{DD} Relative to GND	-0.5V to + 2.9V
Supply Voltage on V _{DDQ} Relative to GND	-0.5V to + V _{DD}
DC Applied to Outputs in High-Z State	-0.5V to V _{DDQ} + 0.5V
DC Input Voltage ^[15]	-0.5V to V _{DD} + 0.5V

Current into Outputs (LOW).....	20 mA
Static Discharge Voltage	> 2001V (per MIL-STD-883, Method 3015)
Latch-Up Current	> 200 mA

Operating Range

Range	Ambient Temperature (T _A)	V _{DD} ^[16]	V _{DDQ} ^[16]
Com'l	0°C to + 70°C	1.8 ± 0.1V	1.4V to V _{DD}
Ind'l	-40°C to + 85°C		

Electrical Characteristics Over the Operating Range^[17]

DC Electrical Characteristics

Parameter	Description	Test Conditions	Min.	Typ.	Max.	Unit
V _{DD}	Power Supply Voltage		1.7	1.8	1.9	V
V _{DDQ}	I/O Supply Voltage		1.4	1.5	V _{DD}	V
V _{OH}	Output HIGH Voltage	Note 18	V _{DDQ} /2 - 0.12		V _{DDQ} /2 + 0.12	V
V _{OL}	Output LOW Voltage	Note 19	V _{DDQ} /2 - 0.12		V _{DDQ} /2 + 0.12	V
V _{OH(LOW)}	Output HIGH Voltage	I _{OH} = -0.1 mA, Nominal Impedance	V _{DDQ} - 0.2		V _{DDQ}	V
V _{OL(LOW)}	Output LOW Voltage	I _{OL} = 0.1 mA, Nominal Impedance	V _{SS}		0.2	V
V _{IH}	Input HIGH Voltage ^[15]		V _{REF} + 0.1		V _{DDQ} + 0.3	V
V _{IL}	Input LOW Voltage ^[15, 20]		-0.3		V _{REF} - 0.1	V
I _X	Input Leakage Current	GND ≤ V _I ≤ V _{DDQ}	-5		5	μA
I _{OZ}	Output Leakage Current	GND ≤ V _I ≤ V _{DDQ} , Output Disabled	-5		5	μA
V _{REF}	Input Reference Voltage ^[21]	Typical value = 0.75V	0.68	0.75	0.95	V
I _{DD}	V _{DD} Operating Supply	V _{DD} = Max., I _{OUT} = 0 mA, f = f _{MAX} = 1/t _{CYC}			400	mA
I _{SB1}	Automatic Power-Down Current	Max. V _{DD} , Both Ports Deselected, V _{IN} ≤ V _{IH} or V _{IN} < V _{IL} , f = f _{MAX} = 1/t _{CYC} , Inputs Static			200	mA

AC Input Requirements

Parameter	Description	Test Conditions	Min.	Typ.	Max.	Unit
V _{IH}	Input HIGH Voltage		V _{REF} + 0.2	-	-	V
V _{IL}	Input LOW Voltage		-	-	V _{REF} - 0.2	V

Thermal Resistance^[22]

Parameter	Description	Test Conditions	165 FBGA Package	Unit
Θ _{JA}	Thermal Resistance (Junction to Ambient)	Test conditions follow standard test methods and procedures for measuring thermal impedance, per EIA/JESD51.	16.7	°C/W
Θ _{JC}	Thermal Resistance (Junction to Case)		2.5	°C/W

Notes:

- Overshoot: V_{IH(AC)} < V_{DDQ} + 0.85V (Pulse width less than t_{CYC}/2), Undershoot: V_{IL(AC)} > -1.5V (Pulse width less than t_{CYC}/2).
- Power-up: Assumes a linear ramp from 0V to V_{DD}(min.) within 200 ms. During this time V_{IH} < V_{DD} and V_{DDQ} ≤ V_{DD}.
- All voltage referenced to Ground.
- Output are impedance controlled. I_{OH} = -(V_{DDQ}/2)/(RQ/5) for values of 175Ω ≤ RQ ≤ 350Ω.
- Output are impedance controlled. I_{OL} = (V_{DDQ}/2)/(RQ/5) for values of 175Ω ≤ RQ ≤ 350Ω.
- This spec is for all inputs except C and C Clock. For C and C Clock, V_{IL}(Max.) = V_{REF} - 0.2V.
- V_{REF}(Min.) = 0.68V or 0.46V_{DDQ}, whichever is larger, V_{REF}(Max.) = 0.95V or 0.54V_{DDQ}, whichever is smaller.
- Tested initially and after any design or process change that may affect these parameters.

Capacitance^[22]

Parameter	Description	Test Conditions	Max.	Unit
C _{IN}	Input Capacitance	T _A = 25°C, f = 1 MHz, V _{DD} = 1.8V, V _{DDQ} = 1.5V	5	pF
C _{CLK}	Clock Input Capacitance		6	pF
C _O	Output Capacitance		7	pF

AC Test Loads and Waveforms

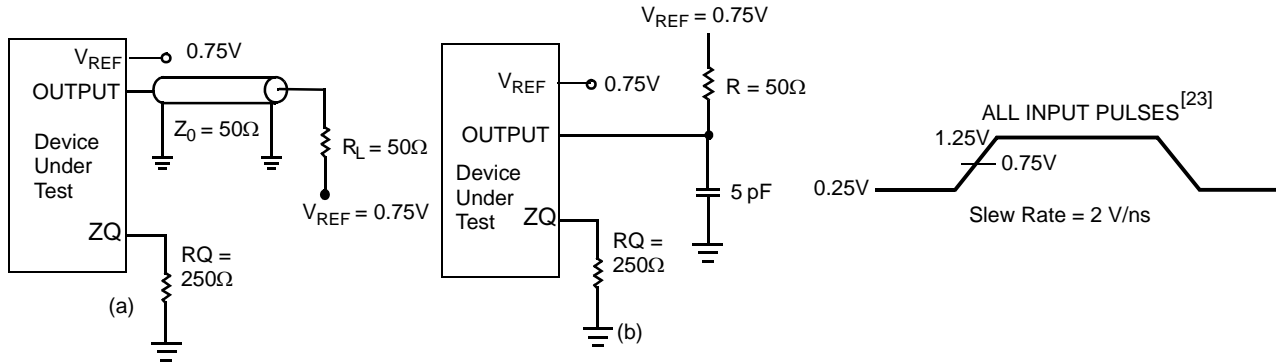

Switching Characteristics Over the Operating Range^[23]

Cypress Parameter	Consortium Parameter	Description	167 MHz		Unit
			Min.	Max.	
t _{Power} ^[24]		V _{CC} (typical) to the First Access Read or Write	10		μs
Cycle Time					
t _{CYC}	t _{KHKH}	K Clock and C Clock Cycle Time	6.0		ns
t _{KH}	t _{KHKL}	Input Clock (K/K and C/C) HIGH	2.4		ns
t _{KL}	t _{KLKH}	Input Clock (K/K and C/C) LOW	2.4		ns
t _{KHKH}	t _{KHKH}	K/K Clock Rise to K/K Clock Rise and C/C to C/C Rise (rising edge to rising edge)	2.7	3.3	ns
t _{KHCH}	t _{KHCH}	K/K Clock Rise to C/C Clock Rise (rising edge to rising edge)	0.0	2.0	ns
Set-up Times					
t _{SA}	t _{SA}	Address Set-up to Clock (K and K) Rise	0.7		ns
t _{SC}	t _{SC}	Control Set-up to Clock (K and K) Rise (RPS, WPS, BWS ₀ , BWS ₁)	0.7		ns
t _{SD}	t _{SD}	D _[x:0] Set-up to Clock (K and K) Rise	0.7		ns
Hold Times					
t _{HA}	t _{HA}	Address Hold after Clock (K and K) Rise	0.7		ns
t _{HC}	t _{HC}	Control Signals Hold after Clock (K and K) Rise (RPS, WPS, BWS ₀ , BWS ₁)	0.7		ns
t _{HD}	t _{HD}	D _[x:0] Hold after Clock (K and K) Rise	0.7		ns
Output Times					
t _{CO}	t _{CHQV}	C/C Clock Rise (or K/K in single clock mode) to Data Valid		2.5	ns
t _{DOH}	t _{CHQX}	Data Output Hold after Output C/C Clock Rise (Active to Active)	1.2		ns
t _{CHZ}	t _{CHZ}	Clock (C and C) Rise to High-Z (Active to High-Z) ^[25, 26]		2.5	ns
t _{CLZ}	t _{CLZ}	Clock (C and C) Rise to Low-Z ^[25, 26]	1.2		ns

Notes:

- 23. Unless otherwise noted, test conditions assume signal transition time of 2V/ns, timing reference levels of 0.75V, Vref = 0.75V, RQ = 250Ω, V_{DDQ} = 1.5V, input pulse levels of 0.25V to 1.25V, and output loading of the specified I_{OL}/I_{OH} and load capacitance shown in (a) of AC test loads.
- 24. This part has a voltage regulator that steps down the voltage internally; t_{Power} is the time power needs to be supplied above V_{DD} minimum initially before a read or write operation can be initiated.
- 25. t_{CHZ}, t_{CLZ}, are specified with a load capacitance of 5 pF as in part (b) of AC Test Loads. Transition is measured ± 100 mV from steady-state voltage.
- 26. At any given voltage and temperature t_{CHZ} is less than t_{CLZ} and, t_{CHZ} less than t_{CO}.

Switching Waveforms^[27, 28, 29]

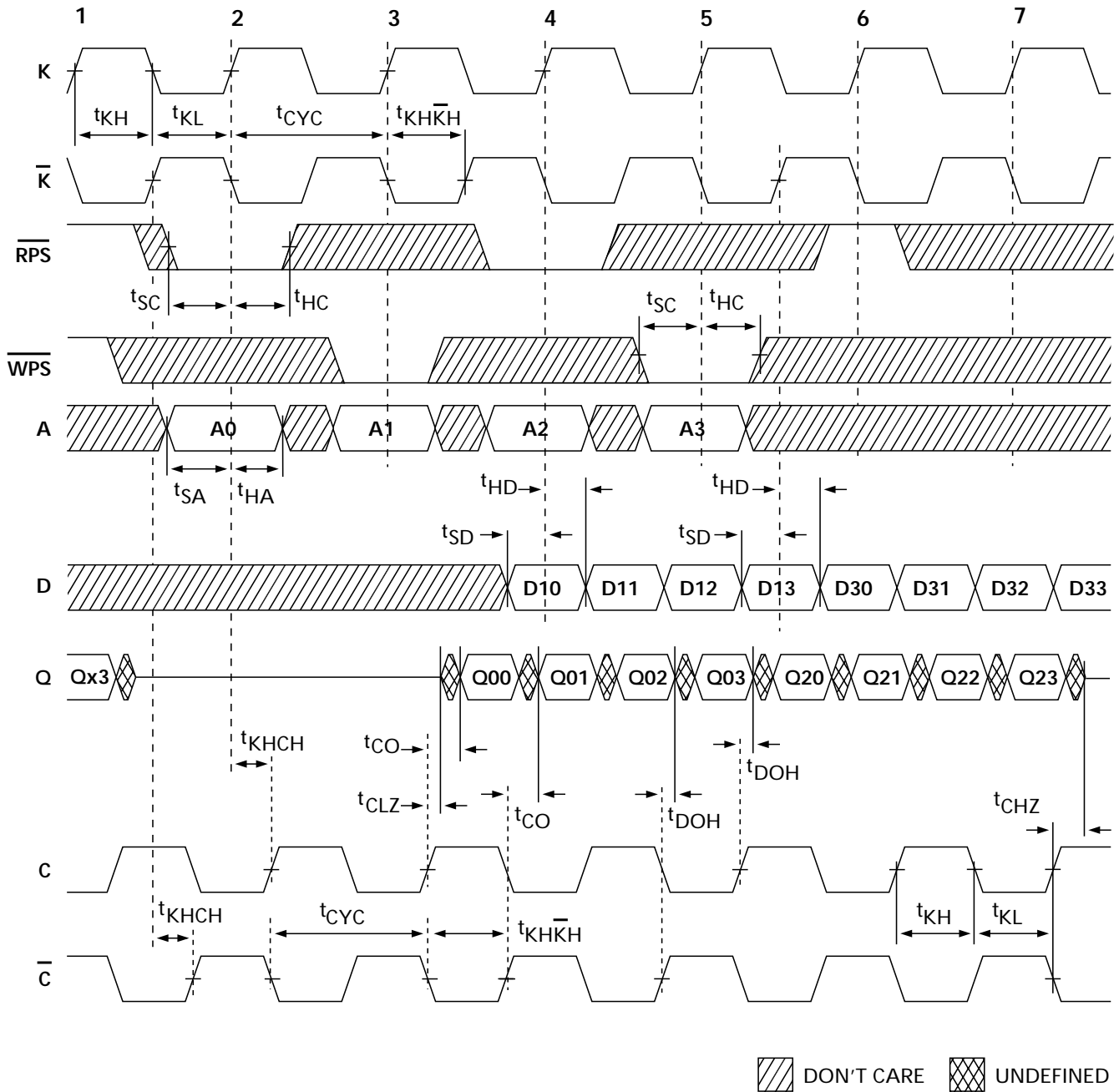

Notes:

27. Q00 refers to output from address A0. Q01 refers to output from the next internal burst address following A0, i.e., A0+1.

28. Outputs are disabled (High-Z) one clock cycle after a NOP.

29. In this example, if address A2 = A1 then data Q20 = D10 and Q21 = D11. Write data is forwarded immediately as read results. This note applies to the whole diagram.

Ordering Information

“Not all of the speed, package and temperature ranges are available. Please contact your local sales representative or visit www.cypress.com for actual products offered”.

Speed (MHz)	Ordering Code	Package Diagram	Package Type	Operating Range
167	CY7C1305BV18-167BZC	51-85180	165-ball Fine Pitch Ball Grid Array (13 x 15 x 1.4 mm)	Commercial
	CY7C1307BV18-167BZC			
	CY7C1305BV18-167BZXC		165-ball Fine Pitch Ball Grid Array (13 x 15 x 1.4 mm) Lead free	
	CY7C1307BV18-167BZXC			
	CY7C1305BV18-167BZI		165-ball Fine Pitch Ball Grid Array (13 x 15 x 1.4 mm)	Industrial
	CY7C1307BV18-167BZI			
	CY7C1305BV18-167BZXI		165-ball Fine Pitch Ball Grid Array (13 x 15 x 1.4 mm) Lead free	
	CY7C1307BV18-167BZXI			

Package Diagram

165-ball FBGA (13 x 15 x 1.4 mm) (51-85180)

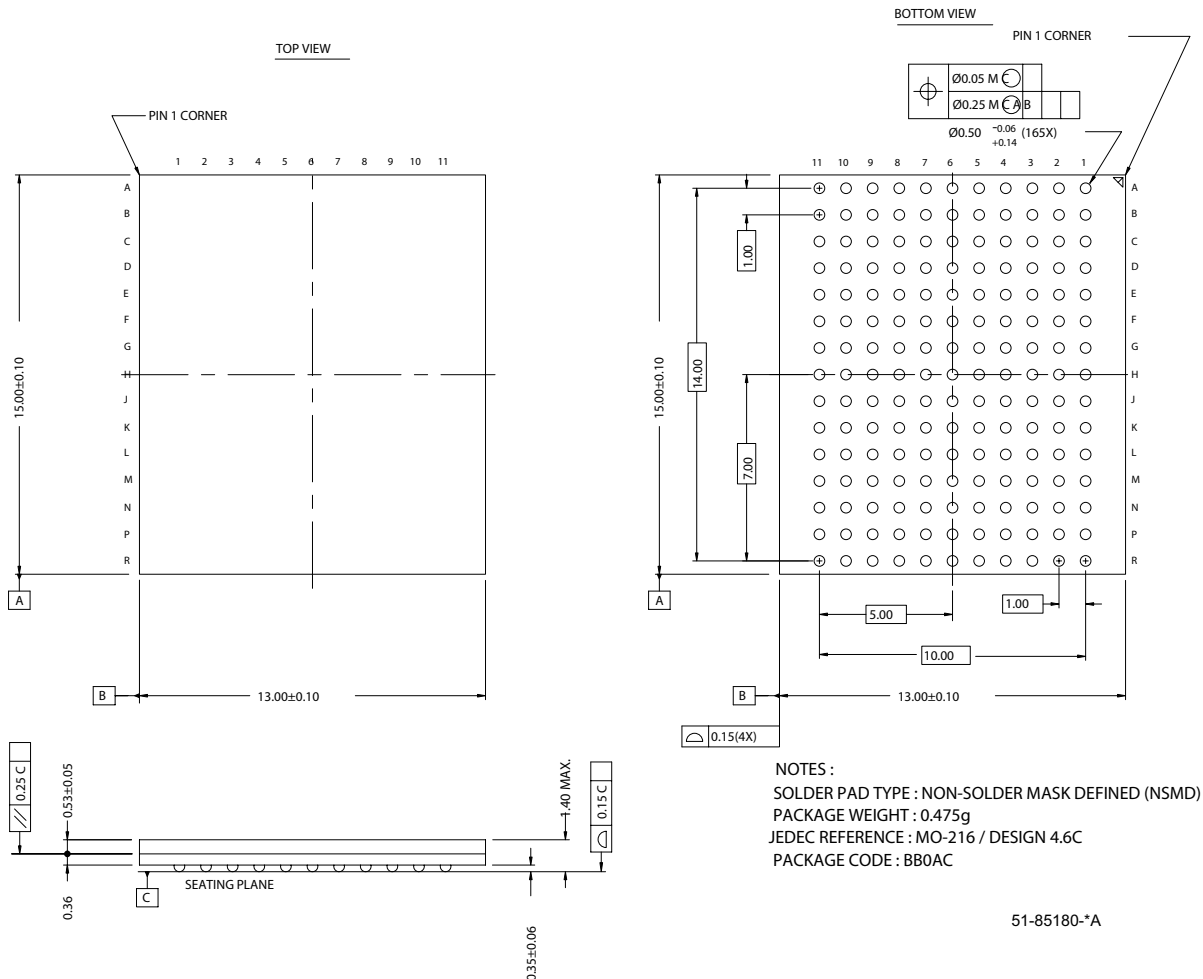

Quad Data Rate SRAM and QDR SRAM comprise a new family of products developed by Cypress, IDT, NEC and Samsung. All products and company names mentioned in this document may be the trademarks of their respective holders.

Document History Page

Document Title: CY7C1305BV18/CY7C1307BV18 18-Mb Burst of 4 Pipelined SRAM with QDR™ Architecture				
Document Number: 38-05629				
REV.	ECN NO.	Issue Date	Orig. of Change	Description of Change
**	253049	See ECN	SYT	New Data Sheet
*A	436864	See ECN	NXR	<p>Converted from Preliminary to Final. Removed 133 MHz & 100 MHz from product offering. Included Industrial Operating Range. Added the Pin Configuration of CY7C1305BV18 on page# 3. Changed C/C Description in the Features Section & Pin Description Table. Changed t_{TCYC} from 100 ns to 50 ns, changed t_{TF} from 10 MHz to 20 MHz and changed t_{TH} and t_{TL} from 40 ns to 20 ns in TAP AC Switching Characteristics table Modified the ZQ pin definition as follows: Alternately, this pin can be connected directly to V_{DDQ}, which enables the minimum impedance mode Included Maximum Ratings for Supply Voltage on V_{DDQ} Relative to GND Changed the Maximum Ratings for DC Input Voltage from V_{DDQ} to V_{DD}. Modified the Description of I_x from Input Load current to Input Leakage Current on page # 15. Modified test condition in note# 16 from $V_{DDQ} < V_{DD}$ to $V_{DDQ} \leq V_{DD}$ Updated the Ordering Information table and replaced the Package Name Column with Package Diagram.</p>