



**CY7C1417AV18**  
**CY7C1428AV18**  
**CY7C1419AV18**  
**CY7C1421AV18**

## 36-Mbit DDR-II SRAM 4-Word Burst Architecture

### Features

- 36-Mbit density (4M x 8, 4M x 9, 2M x 18, 1M x 36)
- 300-MHz clock for high bandwidth
- 4-Word burst for reducing address bus frequency
- Double Data Rate (DDR) interfaces (data transferred at 600 MHz) @ 300 MHz
- Two input clocks (K and  $\bar{K}$ ) for precise DDR timing — SRAM uses rising edges only
- Two input clocks for output data (C and  $\bar{C}$ ) to minimize clock-skew and flight-time mismatches
- Echo clocks (CQ and  $\bar{CQ}$ ) simplify data capture in high-speed systems
- Synchronous internally self-timed writes
- 1.8V core power supply with HSTL inputs and outputs
- Variable drive HSTL output buffers
- Expanded HSTL output voltage (1.4V–V<sub>DD</sub>)
- Available in 165-ball FBGA package (15 x 17 x 1.4 mm)
- Offered in both lead-free and non lead-free packages
- JTAG 1149.1 compatible test access port
- Delay Lock Loop (DLL) for accurate data placement

### Configurations

CY7C1417AV18 – 4M x 8  
 CY7C1428AV18 – 4M x 9  
 CY7C1419AV18 – 2M x 18  
 CY7C1421AV18 – 1M x 36

### Selection Guide

|                             | 300 MHz | 278 MHz | 250 MHz | 200 MHz | 167 MHz | Unit |
|-----------------------------|---------|---------|---------|---------|---------|------|
| Maximum Operating Frequency | 300     | 278     | 250     | 200     | 167     | MHz  |
| Maximum Operating Current   | 825     | 775     | 700     | 600     | 500     | mA   |

### Functional Description

The CY7C1417AV18, CY7C1428AV18, CY7C1419AV18 and CY7C1421AV18 are 1.8V Synchronous Pipelined SRAM equipped with DDR-II (Double Data Rate) architecture. The DDR-II consists of an SRAM core with advanced synchronous peripheral circuitry and a two-bit burst counter. Addresses for Read and Write are latched on alternate rising edges of the input (K) clock. Write data is registered on the rising edges of both K and  $\bar{K}$ . Read data is driven on the rising edges of C and  $\bar{C}$  if provided, or on the rising edge of K and  $\bar{K}$  if C/ $\bar{C}$  are not provided. Each address location is associated with four 8-bit words in the case of CY7C1417AV18 and four 9-bit words in the case of CY7C1428AV18 that burst sequentially into or out of the device. The burst counter always starts with "00" internally in the case of CY7C1417AV18 and CY7C1428AV18. On CY7C1419AV18 and CY7C1421AV18, the burst counter takes in the last two significant bits of the external address and bursts four 18-bit words in the case of CY7C1419AV18, and four 36-bit words in the case of CY7C1421AV18, sequentially into or out of the device.

Asynchronous inputs include output impedance matching input (ZQ). Synchronous data outputs (Q, sharing the same physical pins as the data inputs,  $\bar{D}$ ) are tightly matched to the two output echo clocks CQ/ $\bar{CQ}$ , eliminating the need for separately capturing data from each individual DDR-II SRAM in the system design. Output data clocks (C/ $\bar{C}$ ) enable maximum system clocking and data synchronization flexibility.

All synchronous inputs pass through input registers controlled by the K or  $\bar{K}$  input clocks. All data outputs pass through output registers controlled by the C or  $\bar{C}$  (or K or  $\bar{K}$  in a single clock domain) input clocks. Writes are conducted with on-chip synchronous self-timed write circuitry.

**Logic Block Diagram (CY7C1417AV18)**

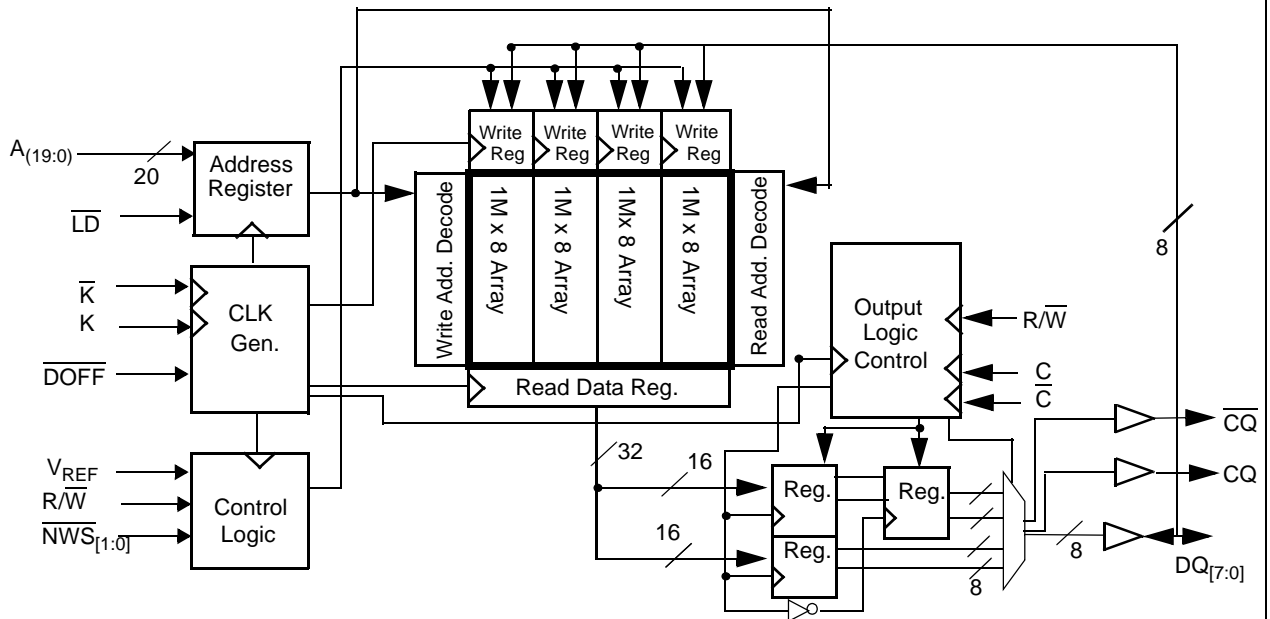

**Logic Block Diagram (CY7C1428AV18)**

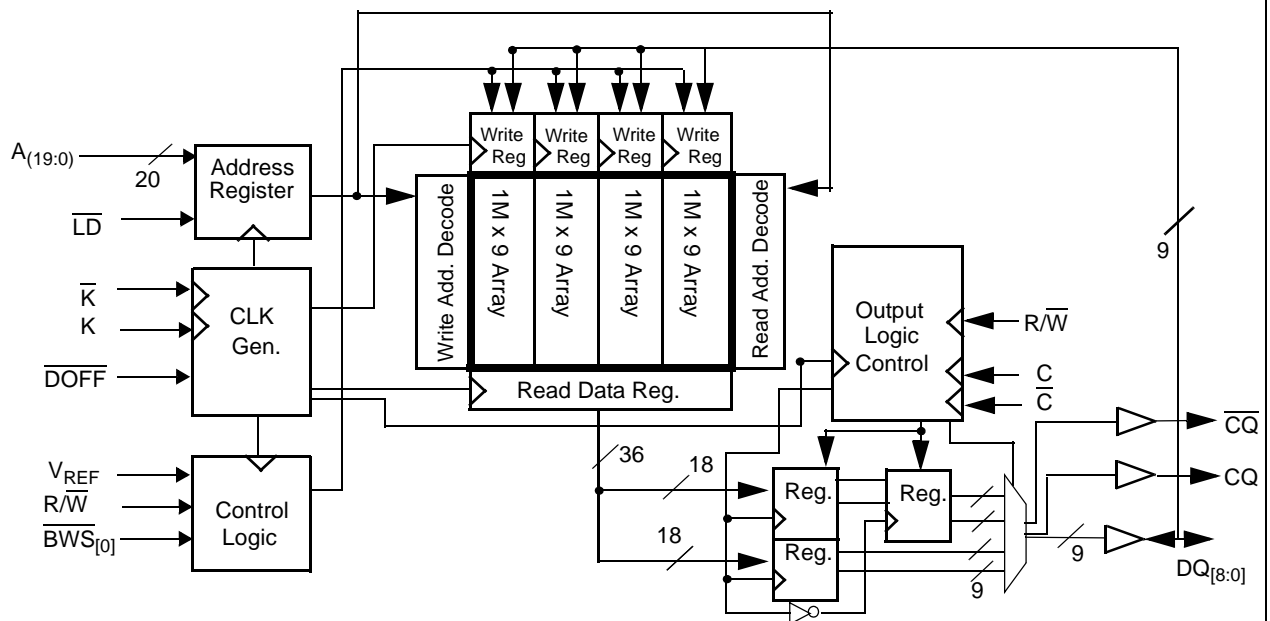

**Logic Block Diagram (CY7C1419AV18)**

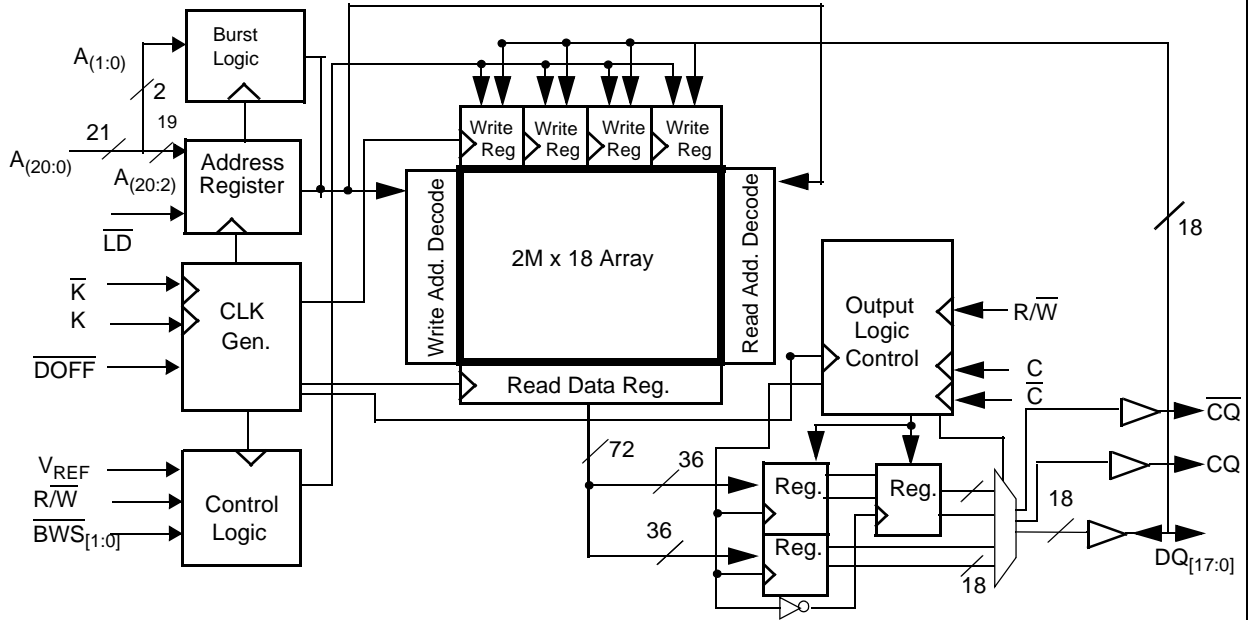

**Logic Block Diagram (CY7C1421AV18)**

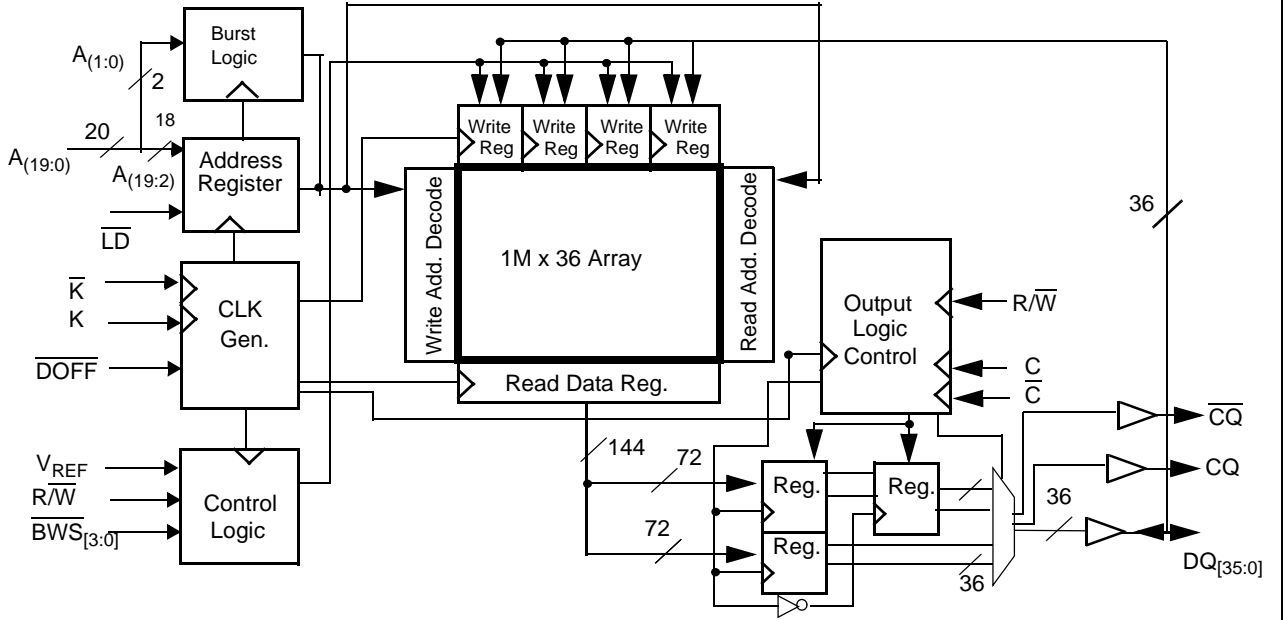



Pin Configurations

165-ball FBGA (15 x 17 x 1.4 mm) Pinout  
 CY7C1417AV18 (4M x 8)

|   | 1                 | 2         | 3         | 4                | 5                  | 6              | 7                  | 8               | 9         | 10        | 11  |
|---|-------------------|-----------|-----------|------------------|--------------------|----------------|--------------------|-----------------|-----------|-----------|-----|
| A | $\overline{CQ}$   | NC/72M    | A         | $R/\overline{W}$ | $\overline{NWS}_1$ | $\overline{K}$ | NC/144M            | $\overline{LD}$ | A         | A         | CQ  |
| B | NC                | NC        | NC        | A                | NC/288M            | K              | $\overline{NWS}_0$ | A               | NC        | NC        | DQ3 |
| C | NC                | NC        | NC        | $V_{SS}$         | A                  | NC             | A                  | $V_{SS}$        | NC        | NC        | NC  |
| D | NC                | NC        | NC        | $V_{SS}$         | $V_{SS}$           | $V_{SS}$       | $V_{SS}$           | $V_{SS}$        | NC        | NC        | NC  |
| E | NC                | NC        | DQ4       | $V_{DDQ}$        | $V_{SS}$           | $V_{SS}$       | $V_{SS}$           | $V_{DDQ}$       | NC        | NC        | DQ2 |
| F | NC                | NC        | NC        | $V_{DDQ}$        | $V_{DD}$           | $V_{SS}$       | $V_{DD}$           | $V_{DDQ}$       | NC        | NC        | NC  |
| G | NC                | NC        | DQ5       | $V_{DDQ}$        | $V_{DD}$           | $V_{SS}$       | $V_{DD}$           | $V_{DDQ}$       | NC        | NC        | NC  |
| H | $\overline{DOFF}$ | $V_{REF}$ | $V_{DDQ}$ | $V_{DDQ}$        | $V_{DD}$           | $V_{SS}$       | $V_{DD}$           | $V_{DDQ}$       | $V_{DDQ}$ | $V_{REF}$ | ZQ  |
| J | NC                | NC        | NC        | $V_{DDQ}$        | $V_{DD}$           | $V_{SS}$       | $V_{DD}$           | $V_{DDQ}$       | NC        | DQ1       | NC  |
| K | NC                | NC        | NC        | $V_{DDQ}$        | $V_{DD}$           | $V_{SS}$       | $V_{DD}$           | $V_{DDQ}$       | NC        | NC        | NC  |
| L | NC                | DQ6       | NC        | $V_{DDQ}$        | $V_{SS}$           | $V_{SS}$       | $V_{SS}$           | $V_{DDQ}$       | NC        | NC        | DQ0 |
| M | NC                | NC        | NC        | $V_{SS}$         | $V_{SS}$           | $V_{SS}$       | $V_{SS}$           | $V_{SS}$        | NC        | NC        | NC  |
| N | NC                | NC        | NC        | $V_{SS}$         | A                  | A              | A                  | $V_{SS}$        | NC        | NC        | NC  |
| P | NC                | NC        | DQ7       | A                | A                  | C              | A                  | A               | NC        | NC        | NC  |
| R | TDO               | TCK       | A         | A                | A                  | $\overline{C}$ | A                  | A               | A         | TMS       | TDI |

CY7C1428AV18 (4M x 9)

|   | 1                 | 2         | 3         | 4                | 5        | 6              | 7                  | 8               | 9         | 10        | 11  |
|---|-------------------|-----------|-----------|------------------|----------|----------------|--------------------|-----------------|-----------|-----------|-----|
| A | $\overline{CQ}$   | NC/72M    | A         | $R/\overline{W}$ | NC       | $\overline{K}$ | NC/144M            | $\overline{LD}$ | A         | A         | CQ  |
| B | NC                | NC        | NC        | A                | NC/288M  | K              | $\overline{BWS}_0$ | A               | NC        | NC        | DQ3 |
| C | NC                | NC        | NC        | $V_{SS}$         | A        | NC             | A                  | $V_{SS}$        | NC        | NC        | NC  |
| D | NC                | NC        | NC        | $V_{SS}$         | $V_{SS}$ | $V_{SS}$       | $V_{SS}$           | $V_{SS}$        | NC        | NC        | NC  |
| E | NC                | NC        | DQ4       | $V_{DDQ}$        | $V_{SS}$ | $V_{SS}$       | $V_{SS}$           | $V_{DDQ}$       | NC        | NC        | DQ2 |
| F | NC                | NC        | NC        | $V_{DDQ}$        | $V_{DD}$ | $V_{SS}$       | $V_{DD}$           | $V_{DDQ}$       | NC        | NC        | NC  |
| G | NC                | NC        | DQ5       | $V_{DDQ}$        | $V_{DD}$ | $V_{SS}$       | $V_{DD}$           | $V_{DDQ}$       | NC        | NC        | NC  |
| H | $\overline{DOFF}$ | $V_{REF}$ | $V_{DDQ}$ | $V_{DDQ}$        | $V_{DD}$ | $V_{SS}$       | $V_{DD}$           | $V_{DDQ}$       | $V_{DDQ}$ | $V_{REF}$ | ZQ  |
| J | NC                | NC        | NC        | $V_{DDQ}$        | $V_{DD}$ | $V_{SS}$       | $V_{DD}$           | $V_{DDQ}$       | NC        | DQ1       | NC  |
| K | NC                | NC        | NC        | $V_{DDQ}$        | $V_{DD}$ | $V_{SS}$       | $V_{DD}$           | $V_{DDQ}$       | NC        | NC        | NC  |
| L | NC                | DQ6       | NC        | $V_{DDQ}$        | $V_{SS}$ | $V_{SS}$       | $V_{SS}$           | $V_{DDQ}$       | NC        | NC        | DQ0 |
| M | NC                | NC        | NC        | $V_{SS}$         | $V_{SS}$ | $V_{SS}$       | $V_{SS}$           | $V_{SS}$        | NC        | NC        | NC  |
| N | NC                | NC        | NC        | $V_{SS}$         | A        | A              | A                  | $V_{SS}$        | NC        | NC        | NC  |
| P | NC                | NC        | DQ7       | A                | A        | C              | A                  | A               | NC        | NC        | DQ8 |
| R | TDO               | TCK       | A         | A                | A        | $\overline{C}$ | A                  | A               | A         | TMS       | TDI |

Pin Configurations (continued)

165-ball FBGA (15 x 17 x 1.4 mm) Pinout

CY7C1419AV18 (2M x 18)

|   | 1                        | 2                | 3                | 4                              | 5                         | 6                     | 7                         | 8                      | 9                | 10               | 11  |
|---|--------------------------|------------------|------------------|--------------------------------|---------------------------|-----------------------|---------------------------|------------------------|------------------|------------------|-----|
| A | $\overline{\text{CQ}}$   | NC/72M           | A                | $\text{R}/\overline{\text{W}}$ | $\overline{\text{BWS}}_1$ | $\overline{\text{K}}$ | NC/144M                   | $\overline{\text{LD}}$ | A                | A                | CQ  |
| B | NC                       | DQ9              | NC               | A                              | NC/288M                   | K                     | $\overline{\text{BWS}}_0$ | A                      | NC               | NC               | DQ8 |
| C | NC                       | NC               | NC               | $V_{\text{SS}}$                | A                         | A0                    | A1                        | $V_{\text{SS}}$        | NC               | DQ7              | NC  |
| D | NC                       | NC               | DQ10             | $V_{\text{SS}}$                | $V_{\text{SS}}$           | $V_{\text{SS}}$       | $V_{\text{SS}}$           | $V_{\text{SS}}$        | NC               | NC               | NC  |
| E | NC                       | NC               | DQ11             | $V_{\text{DDQ}}$               | $V_{\text{SS}}$           | $V_{\text{SS}}$       | $V_{\text{SS}}$           | $V_{\text{DDQ}}$       | NC               | NC               | DQ6 |
| F | NC                       | DQ12             | NC               | $V_{\text{DDQ}}$               | $V_{\text{DD}}$           | $V_{\text{SS}}$       | $V_{\text{DD}}$           | $V_{\text{DDQ}}$       | NC               | NC               | DQ5 |
| G | NC                       | NC               | DQ13             | $V_{\text{DDQ}}$               | $V_{\text{DD}}$           | $V_{\text{SS}}$       | $V_{\text{DD}}$           | $V_{\text{DDQ}}$       | NC               | NC               | NC  |
| H | $\overline{\text{DOFF}}$ | $V_{\text{REF}}$ | $V_{\text{DDQ}}$ | $V_{\text{DDQ}}$               | $V_{\text{DD}}$           | $V_{\text{SS}}$       | $V_{\text{DD}}$           | $V_{\text{DDQ}}$       | $V_{\text{DDQ}}$ | $V_{\text{REF}}$ | ZQ  |
| J | NC                       | NC               | NC               | $V_{\text{DDQ}}$               | $V_{\text{DD}}$           | $V_{\text{SS}}$       | $V_{\text{DD}}$           | $V_{\text{DDQ}}$       | NC               | DQ4              | NC  |
| K | NC                       | NC               | DQ14             | $V_{\text{DDQ}}$               | $V_{\text{DD}}$           | $V_{\text{SS}}$       | $V_{\text{DD}}$           | $V_{\text{DDQ}}$       | NC               | NC               | DQ3 |
| L | NC                       | DQ15             | NC               | $V_{\text{DDQ}}$               | $V_{\text{SS}}$           | $V_{\text{SS}}$       | $V_{\text{SS}}$           | $V_{\text{DDQ}}$       | NC               | NC               | DQ2 |
| M | NC                       | NC               | NC               | $V_{\text{SS}}$                | $V_{\text{SS}}$           | $V_{\text{SS}}$       | $V_{\text{SS}}$           | $V_{\text{SS}}$        | NC               | DQ1              | NC  |
| N | NC                       | NC               | DQ16             | $V_{\text{SS}}$                | A                         | A                     | A                         | $V_{\text{SS}}$        | NC               | NC               | NC  |
| P | NC                       | NC               | DQ17             | A                              | A                         | C                     | A                         | A                      | NC               | NC               | DQ0 |
| R | TDO                      | TCK              | A                | A                              | A                         | $\overline{\text{C}}$ | A                         | A                      | A                | TMS              | TDI |

CY7C1421AV18 (1M x 36)

|   | 1                        | 2                | 3                | 4                              | 5                         | 6                     | 7                         | 8                      | 9                | 10               | 11   |
|---|--------------------------|------------------|------------------|--------------------------------|---------------------------|-----------------------|---------------------------|------------------------|------------------|------------------|------|
| A | $\overline{\text{CQ}}$   | NC/144M          | A                | $\text{R}/\overline{\text{W}}$ | $\overline{\text{BWS}}_2$ | $\overline{\text{K}}$ | $\overline{\text{BWS}}_1$ | $\overline{\text{LD}}$ | A                | NC/72M           | CQ   |
| B | NC                       | DQ27             | DQ18             | A                              | $\overline{\text{BWS}}_3$ | K                     | $\overline{\text{BWS}}_0$ | A                      | NC               | NC               | DQ8  |
| C | NC                       | NC               | DQ28             | $V_{\text{SS}}$                | A                         | A0                    | A1                        | $V_{\text{SS}}$        | NC               | DQ17             | DQ7  |
| D | NC                       | DQ29             | DQ19             | $V_{\text{SS}}$                | $V_{\text{SS}}$           | $V_{\text{SS}}$       | $V_{\text{SS}}$           | $V_{\text{SS}}$        | NC               | NC               | DQ16 |
| E | NC                       | NC               | DQ20             | $V_{\text{DDQ}}$               | $V_{\text{SS}}$           | $V_{\text{SS}}$       | $V_{\text{SS}}$           | $V_{\text{DDQ}}$       | NC               | DQ15             | DQ6  |
| F | NC                       | DQ30             | DQ21             | $V_{\text{DDQ}}$               | $V_{\text{DD}}$           | $V_{\text{SS}}$       | $V_{\text{DD}}$           | $V_{\text{DDQ}}$       | NC               | NC               | DQ5  |
| G | NC                       | DQ31             | DQ22             | $V_{\text{DDQ}}$               | $V_{\text{DD}}$           | $V_{\text{SS}}$       | $V_{\text{DD}}$           | $V_{\text{DDQ}}$       | NC               | NC               | DQ14 |
| H | $\overline{\text{DOFF}}$ | $V_{\text{REF}}$ | $V_{\text{DDQ}}$ | $V_{\text{DDQ}}$               | $V_{\text{DD}}$           | $V_{\text{SS}}$       | $V_{\text{DD}}$           | $V_{\text{DDQ}}$       | $V_{\text{DDQ}}$ | $V_{\text{REF}}$ | ZQ   |
| J | NC                       | NC               | DQ32             | $V_{\text{DDQ}}$               | $V_{\text{DD}}$           | $V_{\text{SS}}$       | $V_{\text{DD}}$           | $V_{\text{DDQ}}$       | NC               | DQ13             | DQ4  |
| K | NC                       | NC               | DQ23             | $V_{\text{DDQ}}$               | $V_{\text{DD}}$           | $V_{\text{SS}}$       | $V_{\text{DD}}$           | $V_{\text{DDQ}}$       | NC               | DQ12             | DQ3  |
| L | NC                       | DQ33             | DQ24             | $V_{\text{DDQ}}$               | $V_{\text{SS}}$           | $V_{\text{SS}}$       | $V_{\text{SS}}$           | $V_{\text{DDQ}}$       | NC               | NC               | DQ2  |
| M | NC                       | NC               | DQ34             | $V_{\text{SS}}$                | $V_{\text{SS}}$           | $V_{\text{SS}}$       | $V_{\text{SS}}$           | $V_{\text{SS}}$        | NC               | DQ11             | DQ1  |
| N | NC                       | DQ35             | DQ25             | $V_{\text{SS}}$                | A                         | A                     | A                         | $V_{\text{SS}}$        | NC               | NC               | DQ10 |
| P | NC                       | NC               | DQ26             | A                              | A                         | C                     | A                         | A                      | NC               | DQ9              | DQ0  |
| R | TDO                      | TCK              | A                | A                              | A                         | $\overline{\text{C}}$ | A                         | A                      | A                | TMS              | TDI  |

## Pin Definitions

| Pin Name   | I/O                      | Pin Description   |
|--|--------------------------|---|
| DQ <sub>[x:0]</sub>  | Input/Output-Synchronous | <b>Data Input/Output signals.</b> Inputs are sampled on the rising edge of K and $\bar{K}$ clocks during valid Write operations. These pins drive out the requested data during a Read operation. Valid data is driven out on the rising edge of both the C and $\bar{C}$ clocks during Read operations or K and $\bar{K}$ when in single clock mode. When Read access is deselected, Q <sub>[x:0]</sub> are automatically tri-stated.<br>CY7C1417AV18 - DQ <sub>[7:0]</sub><br>CY7C1421AV18 - DQ <sub>[8:0]</sub><br>CY7C1428AV18 - DQ <sub>[17:0]</sub><br>CY7C1419AV18 - DQ <sub>[35:0]</sub>  |
| $\bar{LD}$   | Input-Synchronous        | <b>Synchronous Load.</b> This input is brought LOW when a bus cycle sequence is to be defined. This definition includes address and read/write direction. All transactions operate on a burst of 4 data (two clock periods of bus activity).  |
| $\overline{NWS}_0, \overline{NWS}_1$                                     | Input-Synchronous        | <b>Nibble Write Select 0, 1 – active LOW (CY7C1417AV18 only).</b> Sampled on the rising edge of the K and $\bar{K}$ clocks during Write operations. Used to select which nibble is written into the device during the current portion of the Write operations. Nibbles not written remain unaltered.<br>$\overline{NWS}_0$ controls D <sub>[3:0]</sub> and $\overline{NWS}_1$ controls D <sub>[7:4]</sub> .<br>All the Nibble Write Selects are sampled on the same edge as the data. Deselecting a Nibble Write Select will cause the corresponding nibble of data to be ignored and not written into the device.  |
| $\overline{BWS}_0, \overline{BWS}_1, \overline{BWS}_2, \overline{BWS}_3$ | Input-Synchronous        | <b>Byte Write Select 0, 1, 2, and 3 – active LOW.</b> Sampled on the rising edge of the K and $\bar{K}$ clocks during Write operations. Used to select which byte is written into the device during the current portion of the Write operations. Bytes not written remain unaltered.<br>CY7C1428AV18 – $\overline{BWS}_0$ controls D <sub>[8:0]</sub><br>CY7C1419AV18 – $\overline{BWS}_0$ controls D <sub>[8:0]</sub> and $\overline{BWS}_1$ controls D <sub>[17:9]</sub><br>CY7C1421AV18 – $\overline{BWS}_0$ controls D <sub>[8:0]</sub> , $\overline{BWS}_1$ controls D <sub>[17:9]</sub> , $\overline{BWS}_2$ controls D <sub>[26:18]</sub> and $\overline{BWS}_3$ controls D <sub>[35:27]</sub> .<br>All the Byte Write Selects are sampled on the same edge as the data. Deselecting a Byte Write Select will cause the corresponding byte of data to be ignored and not written into the device.  |
| A, A0, A1  | Input-Synchronous        | <b>Address Inputs.</b> These address inputs are multiplexed for both Read and Write operations. Internally, the device is organized as 4M x 8 (four arrays each of 1M x 8) for CY7C1417AV18, 4M x 9 (four arrays each of 1M x 9) for CY7C1428AV18, a single 2M x 18 array for CY7C1419AV18, and a single 1M x 36 array for CY7C1421AV18.<br>CY7C1417AV18 – Since the least two significant bits of the address internally are “00,” only 20 address inputs are needed to access the entire memory array.<br>CY7C1428AV18 – Since the least two significant bits of the address internally are “00,” only 20 address inputs are needed to access the entire memory array.<br>CY7C1419AV18 – A0 and A1 are the inputs to the burst counter. These are incremented in a linear fashion internally. 21 address inputs are needed to access the entire memory array.<br>All the address inputs are ignored when write access is deselected.<br>CY7C1421AV18 – A0 and A1 are the inputs to the burst counter. These are incremented in a linear fashion internally. 20 address inputs are needed to access the entire memory array. |
| R/ $\bar{W}$   | Input-Synchronous        | <b>Synchronous Read/Write Input.</b> When $\bar{LD}$ is LOW, this input designates the access type (Read when R/ $\bar{W}$ is HIGH, Write when R/ $\bar{W}$ is LOW) for loaded address. R/ $\bar{W}$ must meet the set-up and hold times around edge of K.  |
| C  | Output-Clock             | <b>Positive Input Clock for Output Data.</b> C is used in conjunction with $\bar{C}$ to clock out the Read data from the device. C and $\bar{C}$ can be used together to deskew the flight times of various devices on the board back to the controller. See application example for further details.   |
| $\bar{C}$  | Output-Clock             | <b>Negative Input Clock for Output Data.</b> $\bar{C}$ is used in conjunction with C to clock out the Read data from the device. C and $\bar{C}$ can be used together to deskew the flight times of various devices on the board back to the controller. See application example for further details.   |
| K  | Input-Clock              | <b>Positive Input Clock Input.</b> The rising edge of K is used to capture synchronous inputs to the device and to drive out data through Q <sub>[x:0]</sub> when in single clock mode. All accesses are initiated on the rising edge of K.   |
| $\bar{K}$  | Input-Clock              | <b>Negative Input Clock Input.</b> $\bar{K}$ is used to capture synchronous inputs being presented to the device and to drive out data through Q <sub>[x:0]</sub> when in single clock mode.  |

## Pin Definitions (continued)

| Pin Name          | I/O             | Pin Description  |
|-------------------|-----------------|--|
| CQ                | Clock Output    | <b>CQ is referenced with respect to C.</b> This is a free-running clock and is synchronized to the Input clock for output data (C) of the DDR-II. In the single clock mode, CQ is generated with respect to K. The timings for the echo clocks are shown in the AC Timing table.   |
| $\overline{CQ}$   | Clock Output    | $\overline{CQ}$ is referenced with respect to $\overline{C}$ . This is a free-running clock and is synchronized to the Input clock for output data ( $\overline{C}$ ) of the DDR-II. In the single clock mode, $\overline{CQ}$ is generated with respect to K. The timings for the echo clocks are shown in the AC Timing table.   |
| ZQ                | Input           | <b>Output Impedance Matching Input.</b> This input is used to tune the device outputs to the system data bus impedance. CQ, $\overline{CQ}$ , and $Q_{[x:0]}$ output impedance are set to $0.2 \times RQ$ , where RQ is a resistor connected between ZQ and ground. Alternately, this pin can be connected directly to $V_{DDQ}$ , which enables the minimum impedance mode. This pin cannot be connected directly to GND or left unconnected. |
| $\overline{DOFF}$ | Input           | <b>DLL Turn Off - active LOW.</b> Connecting this pin to ground will turn off the DLL inside the device. The timings in the DLL turned off operation will be different from those listed in this data sheet.   |
| TDO               | Output          | <b>TDO for JTAG.</b>   |
| TCK               | Input           | <b>TCK pin for JTAG.</b>   |
| TDI               | Input           | <b>TDI pin for JTAG.</b>   |
| TMS               | Input           | <b>TMS pin for JTAG.</b>   |
| NC                | N/A             | <b>Not connected to the die.</b> Can be tied to any voltage level.   |
| NC/72M            | N/A             | <b>Not connected to the die.</b> Can be tied to any voltage level.   |
| NC/144M           | N/A             | <b>Not connected to the die.</b> Can be tied to any voltage level.   |
| NC/288M           | N/A             | <b>Not connected to the die.</b> Can be tied to any voltage level.   |
| $V_{REF}$         | Input-Reference | <b>Reference Voltage Input.</b> Static input used to set the reference level for HSTL inputs and Outputs as well as AC measurement points.   |
| $V_{DD}$          | Power Supply    | <b>Power supply inputs to the core of the device.</b>  |
| $V_{SS}$          | Ground          | <b>Ground for the device.</b>  |
| $V_{DDQ}$         | Power Supply    | <b>Power supply inputs for the outputs of the device.</b>  |

## Functional Overview

The CY7C1417AV18, CY7C1428AV18, CY7C1419AV18, and CY7C1421AV18 are synchronous pipelined Burst SRAMs equipped with a DDR interface.

Accesses are initiated on the rising edge of the positive input clock (K). All synchronous input timing is referenced from the rising edge of the input clocks (K and  $\overline{K}$ ) and all output timing is referenced to the rising edge of the output clocks (C/ $\overline{C}$  or K/ $\overline{K}$  when in single-clock mode).

All synchronous data inputs ( $D_{[x:0]}$ ) pass through input registers controlled by the rising edge of the input clocks (K and  $\overline{K}$ ). All synchronous data outputs ( $Q_{[x:0]}$ ) pass through output registers controlled by the rising edge of the output clocks (C/ $\overline{C}$  or K/ $\overline{K}$  when in single clock mode).

All synchronous control ( $R/\overline{W}$ ,  $\overline{LD}$ ,  $\overline{BWS}_{[0:X]}$ ) inputs pass through input registers controlled by the rising edge of the input clock (K).

CY7C1428AV18 is described in the following sections. The same basic descriptions apply to CY7C1417AV18, CY7C1421AV18, and CY7C1419AV18.

### Read Operations

The CY7C1428AV18 is organized internally as a 2M x 18 SRAM. Accesses are completed in a burst of four sequential

18-bit data words. Read operations are initiated by asserting R/W HIGH and LD LOW at the rising edge of the positive input clock (K). The address presented to the Address inputs is stored in the Read address register and the least two significant bits of the address are presented to the burst counter. The burst counter increments the address in a linear fashion. Following the next K clock rise the corresponding 18-bit word of data from this address location is driven onto the  $Q_{[17:0]}$  using  $\overline{C}$  as the output timing reference. On the subsequent rising edge of C the next 18-bit data word from the address location generated by the burst counter is driven onto the  $Q_{[17:0]}$ . This process continues until all four 18-bit data words have been driven out onto  $Q_{[17:0]}$ . The requested data will be valid 0.45 ns from the rising edge of the output clock (C or  $\overline{C}$ , or K or  $\overline{K}$  when in single clock mode, 250-MHz and 200-MHz device). In order to maintain the internal logic, each Read access must be allowed to complete. Each Read access consists of four 18-bit data words and takes two clock cycles to complete. Therefore, Read accesses to the device can not be initiated on two consecutive K clock rises. The internal logic of the device will ignore the second Read request. Read accesses can be initiated on every other K clock rise. Doing so will pipeline the data flow such that data is transferred out of the device on every rising edge of the output clocks (C/ $\overline{C}$  or K/ $\overline{K}$  when in single-clock mode).



When Read access is deselected, the CY7C1428AV18 will first complete the pending Read transactions. Synchronous internal circuitry will automatically tri-state the outputs following the next rising edge of the positive output clock (C). This will allow for a seamless transition between devices without the insertion of wait states in a depth expanded memory.

### Write Operations

Write operations are initiated by asserting  $\overline{R/W}$  LOW and  $\overline{LD}$  LOW at the rising edge of the positive input clock (K). The address presented to Address inputs are stored in the Write address register and the least two significant bits of the address are presented to the burst counter. The burst counter increments the address in a linear fashion. On the following K clock rise the data presented to  $D_{[17:0]}$  is latched and stored into the 18-bit Write Data register provided  $\overline{BWS}_{[1:0]}$  are both asserted active. On the subsequent rising edge of the negative input clock ( $\overline{K}$ ) the information presented to  $\overline{D}_{[17:0]}$  is also stored into the Write Data register provided  $\overline{BWS}_{[1:0]}$  are both asserted active. This process continues for one more cycle until four 18-bit words (a total of 72 bits) of data are stored in the SRAM. The 72 bits of data are then written into the memory array at the specified location. Therefore, Write accesses to the device can not be initiated on two consecutive K clock rises. The internal logic of the device will ignore the second Write request. Write accesses can be initiated on every other rising edge of the positive input clock (K). Doing so will pipeline the data flow such that 18 bits of data can be transferred into the device on every rising edge of the input clocks (K and  $\overline{K}$ ).

When Write access is deselected, the device will ignore all inputs after the pending Write operations have been completed.

### Byte Write Operations

Byte Write operations are supported by the CY7C1428AV18. A Write operation is initiated as described in the Write Operations section above. The bytes that are written are determined by  $\overline{BWS}_0$  and  $\overline{BWS}_1$ , which are sampled with each set of 18-bit data words. Asserting the appropriate Byte Write Select input during the data portion of a write will allow the data being presented to be latched and written into the device. Deasserting the Byte Write Select input during the data portion of a Write will allow the data stored in the device for that byte to remain unaltered. This feature can be used to simplify Read/Modify/Write operations to a Byte Write operation.

### Single Clock Mode

The CY7C1428AV18 can be used with a single clock that controls both the input and output registers. In this mode the device will recognize only a single pair of input clocks (K and  $\overline{K}$ ) that control both the input and output registers. This operation is identical to the operation if the device had zero skew between the  $\overline{K}/K$  and  $\overline{C}/C$  clocks. All timing parameters remain the same in this mode. To use this mode of operation, the user must tie C and  $\overline{C}$  HIGH at power-on. This function is a strap option and not alterable during device operation.

### DDR Operation

The CY7C1428AV18 enables high-performance operation through high clock frequencies (achieved through pipelining) and double data rate mode of operation. The CY7C1428AV18 requires a No Operation (NOP) cycle when transitioning from a Read to a Write cycle. At higher frequencies, some applications may require a second NOP cycle to prevent contention.

If a Read occurs after a Write cycle, address and data for the Write are stored in registers. The write information must be stored because the SRAM can not perform the last word Write to the array without conflicting with the Read. The data stays in this register until the next Write cycle occurs. On the first Write cycle after the Read(s), the stored data from the earlier Write will be written into the SRAM array. This is called a Posted Write.

### Depth Expansion

Depth expansion requires replicating the  $\overline{LD}$  control signal for each bank. All other control signals can be common between banks as appropriate.

### Programmable Impedance

An external resistor, RQ must be connected between the ZQ pin on the SRAM and  $V_{SS}$  to allow the SRAM to adjust its output driver impedance. The value of RQ must be 5x the value of the intended line impedance driven by the SRAM. The allowable range of RQ to guarantee impedance matching with a tolerance of  $\pm 15\%$  is between  $175\Omega$  and  $350\Omega$ , with  $V_{DDQ} = 1.5V$ . The output impedance is adjusted every 1024 cycles upon power-up to account for drifts in supply voltage and temperature.

### Echo Clocks

Echo clocks are provided on the DDR-II to simplify data capture on high-speed systems. Two echo clocks are generated by the DDR-II. CQ is referenced with respect to C and  $\overline{CQ}$  is referenced with respect to  $\overline{C}$ . These are free running clocks and are synchronized to the output clock of the DDR-II. In the single clock mode, CQ is generated with respect to K and  $\overline{CQ}$  is generated with respect to  $\overline{K}$ . The timings for the echo clocks are shown in the AC Timing table.

### DLL

These chips utilize a Delay Lock Loop (DLL) that is designed to function between 80 MHz and the specified maximum clock frequency. During power-up, when the DOFF is tied HIGH, the DLL gets locked after 1024 cycles of stable clock. The DLL can also be reset by slowing or stopping the input clock K and  $\overline{K}$  for a minimum of 30 ns. However, it is not necessary for the DLL to be specifically reset in order to lock the DLL to the desired frequency. The DLL will automatically lock 1024 clock cycles after a stable clock is presented. The DLL may be disabled by applying ground to the DOFF pin. For information refer to the application note "DLL Considerations in QDRII/DDRII/QDRII+/DDRII+".



### Application Example<sup>[1]</sup>

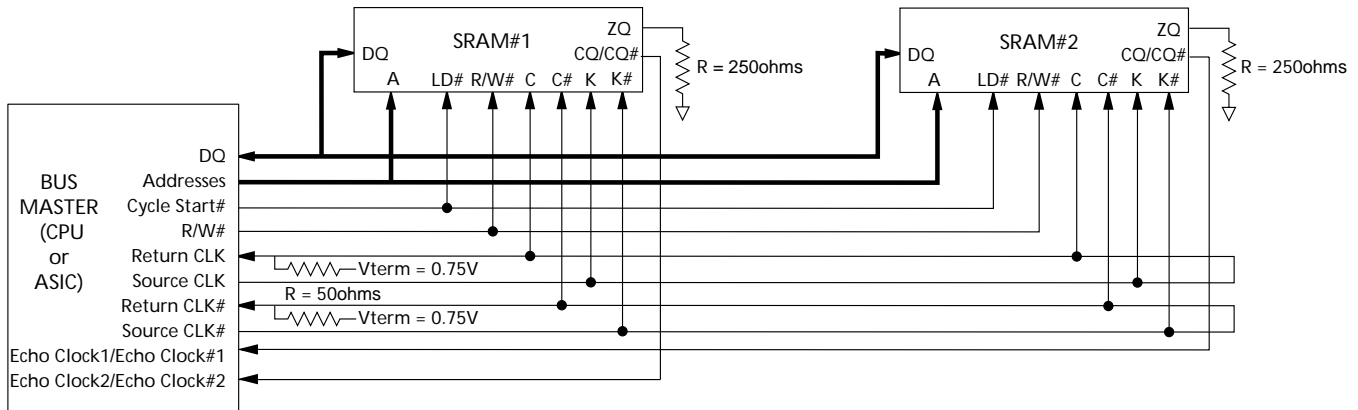

### Truth Table<sup>[2, 3, 4, 5, 6, 7]</sup>

| Operation   | K       | $\overline{\text{LD}}$ | $\overline{\text{R/W}}$ | DQ   | DQ   | DQ   | DQ   |
|---|---------|------------------------|-------------------------|--|--|--|--|
| Write Cycle:<br>Load address; wait one cycle; input write data on four consecutive K and $\overline{\text{K}}$ rising edges.    | L-H     | L                      | L                       | D(A1) at $\text{K}(t+1) \uparrow$            | D(A2) at $\overline{\text{K}}(t+1) \uparrow$ | D(A3) at $\text{K}(t+2) \uparrow$            | D(A4) at $\overline{\text{K}}(t+2) \uparrow$ |
| Read Cycle:<br>Load address; wait one and a half cycle; read data on four consecutive $\overline{\text{C}}$ and C rising edges. | L-H     | L                      | H                       | Q(A1) at $\overline{\text{C}}(t+1) \uparrow$ | Q(A2) at $\text{C}(t+2) \uparrow$            | Q(A3) at $\overline{\text{C}}(t+2) \uparrow$ | Q(A4) at $\text{C}(t+3) \uparrow$            |
| NOP: No Operation   | L-H     | H                      | X                       | High-Z                                       | High-Z                                       | High-Z                                       | High-Z                                       |
| Standby: Clock Stopped  | Stopped | X                      | X                       | Previous State                               | Previous State                               | Previous State                               | Previous State                               |

### Linear Burst Address Table (CY7C1419AV18 and CY7C1428AV18)

| First Address (External) | Second Address (Internal) | Third Address (Internal) | Fourth Address (Internal) |
|--------------------------|---------------------------|--------------------------|---------------------------|
| X..X00                   | X..X01                    | X..X10                   | X..X11                    |
| X..X01                   | X..X10                    | X..X11                   | X..X00                    |
| X..X10                   | X..X11                    | X..X00                   | X..X01                    |
| X..X11                   | X..X00                    | X..X01                   | X..X10                    |

#### Notes:

- The above application shows 2 DDR-II being used.
- X = "Don't Care," H = Logic HIGH, L = Logic LOW,  $\uparrow$  represents rising edge.
- Device will power-up deselected and the outputs in a tri-state condition.
- On CY7C1419AV18 and CY7C1421AV18, "A1" represents address location latched by the devices when transaction was initiated and A2, A3, A4 represents the addresses sequence in the burst. On CY7C1417AV18, "A1" represents A + '00', A2 represents A + '01', "A3" represents A + '10' and "A4" represents A + '11'.
- "t" represents the cycle at which a Read/Write operation is started. t+1, t+2 and t+3 are the first, second and third clock cycles succeeding the "t" clock cycle.
- Data inputs are registered at K and  $\overline{\text{K}}$  rising edges. Data outputs are delivered on C and  $\overline{\text{C}}$  rising edges, except when in single clock mode.
- It is recommended that  $\text{K} = \overline{\text{K}}$  and  $\text{C} = \overline{\text{C}}$  = HIGH when clock is stopped. This is not essential, but permits most rapid restart by overcoming transmission line charging symmetrically.

**Write Cycle Descriptions**(CY7C1417AV18 and CY7C1419AV18)<sup>[2, 8]</sup>

| $\overline{BWS}_0, \overline{NWS}_0$ | $\overline{BWS}_1, \overline{NWS}_1$ | K   | $\overline{K}$ | Comments  |
|--------------------------------------|--------------------------------------|-----|----------------|---|
| L                                    | L                                    | L-H | -              | During the Data portion of a Write sequence:<br>CY7C1417AV18 – both nibbles ( $D_{[7:0]}$ ) are written into the device,<br>CY7C1419AV18 – both bytes ( $D_{[17:0]}$ ) are written into the device.   |
| L                                    | L                                    | -   | L-H            | During the Data portion of a Write sequence:<br>CY7C1417AV18 – both nibbles ( $D_{[7:0]}$ ) are written into the device,<br>CY7C1419AV18 – both bytes ( $D_{[17:0]}$ ) are written into the device.   |
| L                                    | H                                    | L-H | -              | During the Data portion of a Write sequence:<br>CY7C1417AV18 – only the lower nibble ( $D_{[3:0]}$ ) is written into the device. $D_{[7:4]}$ will remain unaltered,<br>CY7C1419AV18 – only the lower byte ( $D_{[8:0]}$ ) is written into the device. $D_{[17:9]}$ will remain unaltered. |
| L                                    | H                                    | -   | L-H            | During the Data portion of a Write sequence:<br>CY7C1417AV18 – only the lower nibble ( $D_{[3:0]}$ ) is written into the device. $D_{[7:4]}$ will remain unaltered,<br>CY7C1419AV18 – only the lower byte ( $D_{[8:0]}$ ) is written into the device. $D_{[17:9]}$ will remain unaltered. |
| H                                    | L                                    | L-H | -              | During the Data portion of a Write sequence:<br>CY7C1417AV18 – only the upper nibble ( $D_{[7:4]}$ ) is written into the device. $D_{[3:0]}$ will remain unaltered,<br>CY7C1419AV18 – only the upper byte ( $D_{[17:9]}$ ) is written into the device. $D_{[8:0]}$ will remain unaltered. |
| H                                    | L                                    | -   | L-H            | During the Data portion of a Write sequence:<br>CY7C1417AV18 – only the upper nibble ( $D_{[7:4]}$ ) is written into the device. $D_{[3:0]}$ will remain unaltered,<br>CY7C1419AV18 – only the upper byte ( $D_{[17:9]}$ ) is written into the device. $D_{[8:0]}$ will remain unaltered. |
| H                                    | H                                    | L-H | -              | No data is written into the devices during this portion of a Write operation.   |
| H                                    | H                                    | -   | L-H            | No data is written into the devices during this portion of a Write operation.   |

**Write Cycle Descriptions** (CY7C1421AV18)<sup>[2, 8]</sup>

| $\overline{BWS}_0$ | $\overline{BWS}_1$ | $\overline{BWS}_2$ | $\overline{BWS}_3$ | K   | $\overline{K}$ | Comments   |
|--------------------|--------------------|--------------------|--------------------|-----|----------------|--|
| L                  | L                  | L                  | L                  | L-H | -              | During the Data portion of a Write sequence, all four bytes ( $D_{[35:0]}$ ) are written into the device.  |
| L                  | L                  | L                  | L                  | -   | L-H            | During the Data portion of a Write sequence, all four bytes ( $D_{[35:0]}$ ) are written into the device.  |
| L                  | H                  | H                  | H                  | L-H | -              | During the Data portion of a Write sequence, only the lower byte ( $D_{[8:0]}$ ) is written into the device. $D_{[35:9]}$ will remain unaltered.               |
| L                  | H                  | H                  | H                  | -   | L-H            | During the Data portion of a Write sequence, only the lower byte ( $D_{[8:0]}$ ) is written into the device. $D_{[35:9]}$ will remain unaltered.               |
| H                  | L                  | H                  | H                  | L-H | -              | During the Data portion of a Write sequence, only the byte ( $D_{[17:9]}$ ) is written into the device. $D_{[8:0]}$ and $D_{[35:18]}$ will remain unaltered.   |
| H                  | L                  | H                  | H                  | -   | L-H            | During the Data portion of a Write sequence, only the byte ( $D_{[17:9]}$ ) is written into the device. $D_{[8:0]}$ and $D_{[35:18]}$ will remain unaltered.   |
| H                  | H                  | L                  | H                  | L-H | -              | During the Data portion of a Write sequence, only the byte ( $D_{[26:18]}$ ) is written into the device. $D_{[17:0]}$ and $D_{[35:27]}$ will remain unaltered. |
| H                  | H                  | L                  | H                  | -   | L-H            | During the Data portion of a Write sequence, only the byte ( $D_{[26:18]}$ ) is written into the device. $D_{[17:0]}$ and $D_{[35:27]}$ will remain unaltered. |
| H                  | H                  | H                  | L                  | L-H | -              | During the Data portion of a Write sequence, only the byte ( $D_{[35:27]}$ ) is written into the device. $D_{[26:0]}$ will remain unaltered.                   |

**Note:**

8. Assumes a Write cycle was initiated per the Write Cycle Description Truth Table.  $\overline{NWS}_0$ ,  $\overline{NWS}_1$ ,  $\overline{BWS}_0$ ,  $\overline{BWS}_1$ ,  $\overline{BWS}_2$ ,  $\overline{BWS}_3$  can be altered on different portions of a Write cycle, as long as the set-up and hold requirements are achieved.



**Write Cycle Descriptions (CY7C1421AV18)<sup>[2, 8]</sup> (continued)**

| $\overline{BWS}_0$ | $\overline{BWS}_1$ | $\overline{BWS}_2$ | $\overline{BWS}_3$ | K   | $\overline{K}$ | Comments  |
|--------------------|--------------------|--------------------|--------------------|-----|----------------|---|
| H                  | H                  | H                  | L                  | -   | L-H            | During the Data portion of a Write sequence, only the byte (D <sub>[35:27]</sub> ) is written into the device. D <sub>[26:0]</sub> will remain unaltered. |
| H                  | H                  | H                  | H                  | L-H | -              | No data is written into the device during this portion of a Write operation.  |
| H                  | H                  | H                  | H                  | -   | L-H            | No data is written into the device during this portion of a Write operation.  |

**Write Cycle Descriptions (CY7C1428AV18)<sup>[2, 8]</sup>**

| $\overline{BWS}_0$ | K   | $\overline{K}$ | Comments   |
|--------------------|-----|----------------|--|
| L                  | L-H | -              | During the Data portion of a Write sequence, the single byte (D <sub>[8:0]</sub> ) is written into the device. |
| L                  | -   | L-H            | During the Data portion of a Write sequence, the single byte (D <sub>[8:0]</sub> ) is written into the device. |
| H                  | L-H | -              | No data is written into the device during this portion of a Write operation.                                   |
| H                  | -   | L-H            | No data is written into the device during this portion of a Write operation.                                   |

## IEEE 1149.1 Serial Boundary Scan (JTAG)

These SRAMs incorporate a serial boundary scan test access port (TAP) in the FBGA package. This part is fully compliant with IEEE Standard #1149.1-1900. The TAP operates using JEDEC standard 1.8V I/O logic levels.

### Disabling the JTAG Feature

It is possible to operate the SRAM without using the JTAG feature. To disable the TAP controller, TCK must be tied LOW ( $V_{SS}$ ) to prevent clocking of the device. TDI and TMS are internally pulled up and may be unconnected. They may alternately be connected to  $V_{DD}$  through a pull-up resistor. TDO should be left unconnected. Upon power-up, the device will come up in a reset state which will not interfere with the operation of the device.

### Test Access Port—Test Clock

The test clock is used only with the TAP controller. All inputs are captured on the rising edge of TCK. All outputs are driven from the falling edge of TCK.

### Test Mode Select

The TMS input is used to give commands to the TAP controller and is sampled on the rising edge of TCK. It is allowable to leave this pin unconnected if the TAP is not used. The pin is pulled up internally, resulting in a logic HIGH level.

### Test Data-In (TDI)

The TDI pin is used to serially input information into the registers and can be connected to the input of any of the registers. The register between TDI and TDO is chosen by the instruction that is loaded into the TAP instruction register. For information on loading the instruction register, see the TAP Controller State Diagram. TDI is internally pulled up and can be unconnected if the TAP is unused in an application. TDI is connected to the most significant bit (MSB) on any register.

### Test Data-Out (TDO)

The TDO output pin is used to serially clock data-out from the registers. The output is active depending upon the current state of the TAP state machine (see Instruction codes). The output changes on the falling edge of TCK. TDO is connected to the least significant bit (LSB) of any register.

### Performing a TAP Reset

A Reset is performed by forcing TMS HIGH ( $V_{DD}$ ) for five rising edges of TCK. This RESET does not affect the operation of the SRAM and may be performed while the SRAM is operating. At power-up, the TAP is reset internally to ensure that TDO comes up in a high-Z state.

### TAP Registers

Registers are connected between the TDI and TDO pins and allow data to be scanned into and out of the SRAM test circuitry. Only one register can be selected at a time through the instruction registers. Data is serially loaded into the TDI pin on the rising edge of TCK. Data is output on the TDO pin on the falling edge of TCK.

#### *Instruction Register*

Three-bit instructions can be serially loaded into the instruction register. This register is loaded when it is placed between the

TDI and TDO pins as shown in TAP Controller Block Diagram. Upon power-up, the instruction register is loaded with the IDCODE instruction. It is also loaded with the IDCODE instruction if the controller is placed in a reset state as described in the previous section.

When the TAP controller is in the Capture IR state, the two least significant bits are loaded with a binary “01” pattern to allow for fault isolation of the board level serial test path.

#### *Bypass Register*

To save time when serially shifting data through registers, it is sometimes advantageous to skip certain chips. The bypass register is a single-bit register that can be placed between TDI and TDO pins. This allows data to be shifted through the SRAM with minimal delay. The bypass register is set LOW ( $V_{SS}$ ) when the BYPASS instruction is executed.

#### *Boundary Scan Register*

The boundary scan register is connected to all of the input and output pins on the SRAM. Several no connect (NC) pins are also included in the scan register to reserve pins for higher density devices.

The boundary scan register is loaded with the contents of the RAM Input and Output ring when the TAP controller is in the Capture-DR state and is then placed between the TDI and TDO pins when the controller is moved to the Shift-DR state. The EXTEST, SAMPLE/PRELOAD and SAMPLE Z instructions can be used to capture the contents of the Input and Output ring.

The Boundary Scan Order tables show the order in which the bits are connected. Each bit corresponds to one of the bumps on the SRAM package. The MSB of the register is connected to TDI, and the LSB is connected to TDO.

#### *Identification (ID) Register*

The ID register is loaded with a vendor-specific, 32-bit code during the Capture-DR state when the IDCODE command is loaded in the instruction register. The IDCODE is hardwired into the SRAM and can be shifted out when the TAP controller is in the Shift-DR state. The ID register has a vendor code and other information described in the Identification Register Definitions table.

### TAP Instruction Set

Eight different instructions are possible with the three-bit instruction register. All combinations are listed in the Instruction Code table. Three of these instructions are listed as RESERVED and should not be used. The other five instructions are described in detail below.

Instructions are loaded into the TAP controller during the Shift-IR state when the instruction register is placed between TDI and TDO. During this state, instructions are shifted through the instruction register through the TDI and TDO pins. To execute the instruction once it is shifted in, the TAP controller needs to be moved into the Update-IR state.

#### *IDCODE*

The IDCODE instruction causes a vendor-specific, 32-bit code to be loaded into the instruction register. It also places the instruction register between the TDI and TDO pins and allows the IDCODE to be shifted out of the device when the TAP controller enters the Shift-DR state. The IDCODE instruction

is loaded into the instruction register upon power-up or whenever the TAP controller is given a test logic reset state.

#### *SAMPLE Z*

The SAMPLE Z instruction causes the boundary scan register to be connected between the TDI and TDO pins when the TAP controller is in a Shift-DR state. The SAMPLE Z command puts the output bus into a High-Z state until the next command is given during the “Update IR” state.

#### *SAMPLE/PRELOAD*

SAMPLE/PRELOAD is a 1149.1 mandatory instruction. When the SAMPLE/PRELOAD instructions are loaded into the instruction register and the TAP controller is in the Capture-DR state, a snapshot of data on the inputs and output pins is captured in the boundary scan register.

The user must be aware that the TAP controller clock can only operate at a frequency up to 20 MHz, while the SRAM clock operates more than an order of magnitude faster. Because there is a large difference in the clock frequencies, it is possible that during the Capture-DR state, an input or output will undergo a transition. The TAP may then try to capture a signal while in transition (metastable state). This will not harm the device, but there is no guarantee as to the value that will be captured. Repeatable results may not be possible.

To guarantee that the boundary scan register will capture the correct value of a signal, the SRAM signal must be stabilized long enough to meet the TAP controller's capture set-up plus hold times ( $t_{CS}$  and  $t_{CH}$ ). The SRAM clock input might not be captured correctly if there is no way in a design to stop (or slow) the clock during a SAMPLE/PRELOAD instruction. If this is an issue, it is still possible to capture all other signals and simply ignore the value of the CK and CK captured in the boundary scan register.

Once the data is captured, it is possible to shift out the data by putting the TAP into the Shift-DR state. This places the boundary scan register between the TDI and TDO pins.

PRELOAD allows an initial data pattern to be placed at the latched parallel outputs of the boundary scan register cells prior to the selection of another boundary scan test operation.

The shifting of data for the SAMPLE and PRELOAD phases can occur concurrently when required—that is, while data captured is shifted out, the preloaded data can be shifted in.

#### *BYPASS*

When the BYPASS instruction is loaded in the instruction register and the TAP is placed in a Shift-DR state, the bypass register is placed between the TDI and TDO pins. The advantage of the BYPASS instruction is that it shortens the boundary scan path when multiple devices are connected together on a board.

#### *EXTEST*

The EXTEST instruction enables the preloaded data to be driven out through the system output pins. This instruction also selects the boundary scan register to be connected for serial access between the TDI and TDO in the shift-DR controller state.

#### *EXTEST Output Bus Tri-State*

IEEE Standard 1149.1 mandates that the TAP controller be able to put the output bus into a tri-state mode.

The boundary scan register has a special bit located at bit #180. When this scan cell, called the “extest output bus tri-state”, is latched into the preload register during the “Update-DR” state in the TAP controller, it will directly control the state of the output (Q-bus) pins, when the EXTEST is entered as the current instruction. When HIGH, it will enable the output buffers to drive the output bus. When LOW, this bit will place the output bus into a High-Z condition.

This bit can be set by entering the SAMPLE/PRELOAD or EXTEST command, and then shifting the desired bit into that cell, during the “Shift-DR” state. During “Update-DR”, the value loaded into that shift-register cell will latch into the preload register. When the EXTEST instruction is entered, this bit will directly control the output Q-bus pins. Note that this bit is pre-set HIGH to enable the output when the device is powered-up, and also when the TAP controller is in the “Test-Logic-Reset” state.

#### *Reserved*

These instructions are not implemented but are reserved for future use. Do not use these instructions.

TAP Controller State Diagram<sup>[9]</sup>

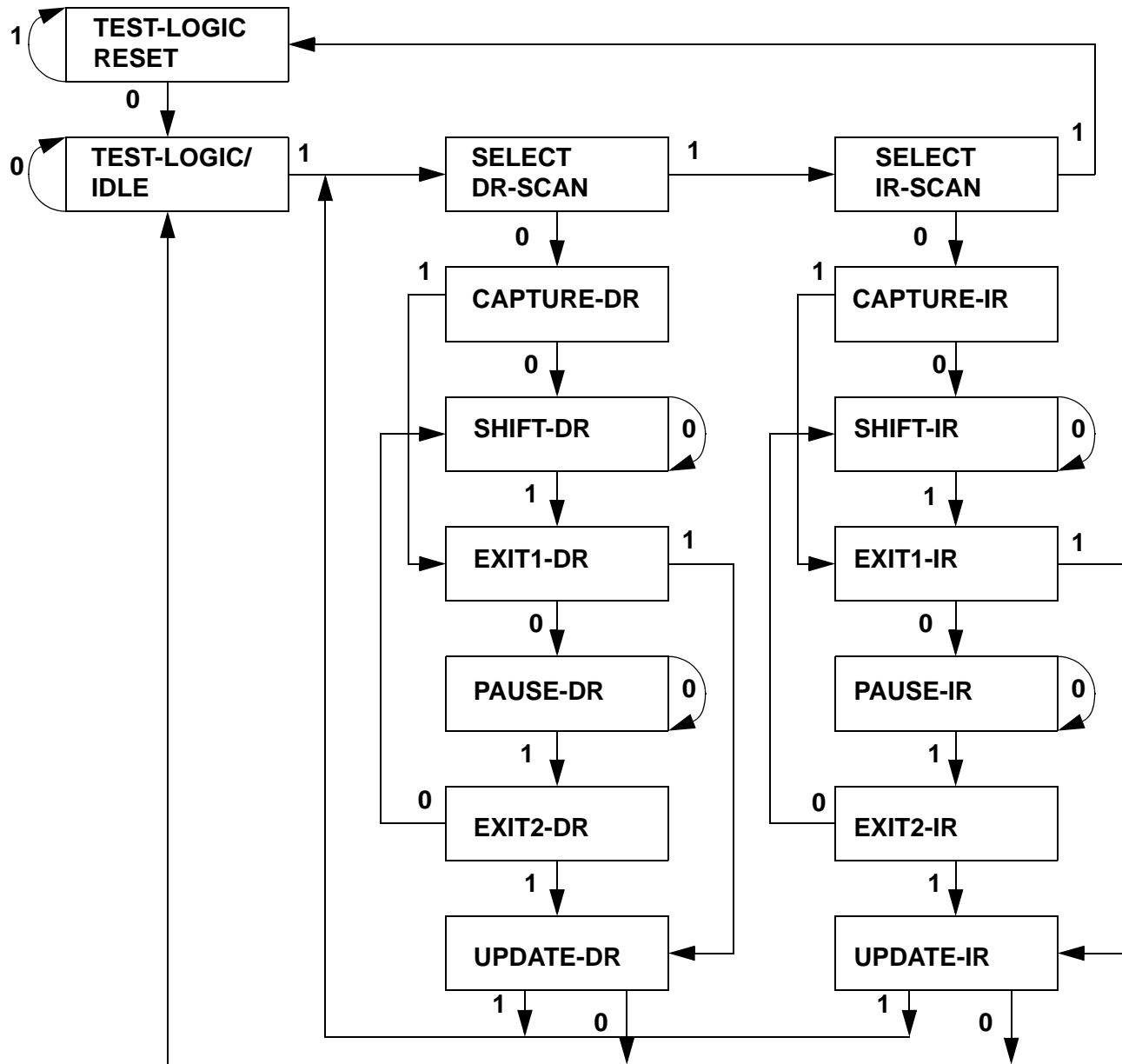

**Note:**  
 9. The 0/1 next to each state represents the value at TMS at the rising edge of TCK.



### TAP Controller Block Diagram

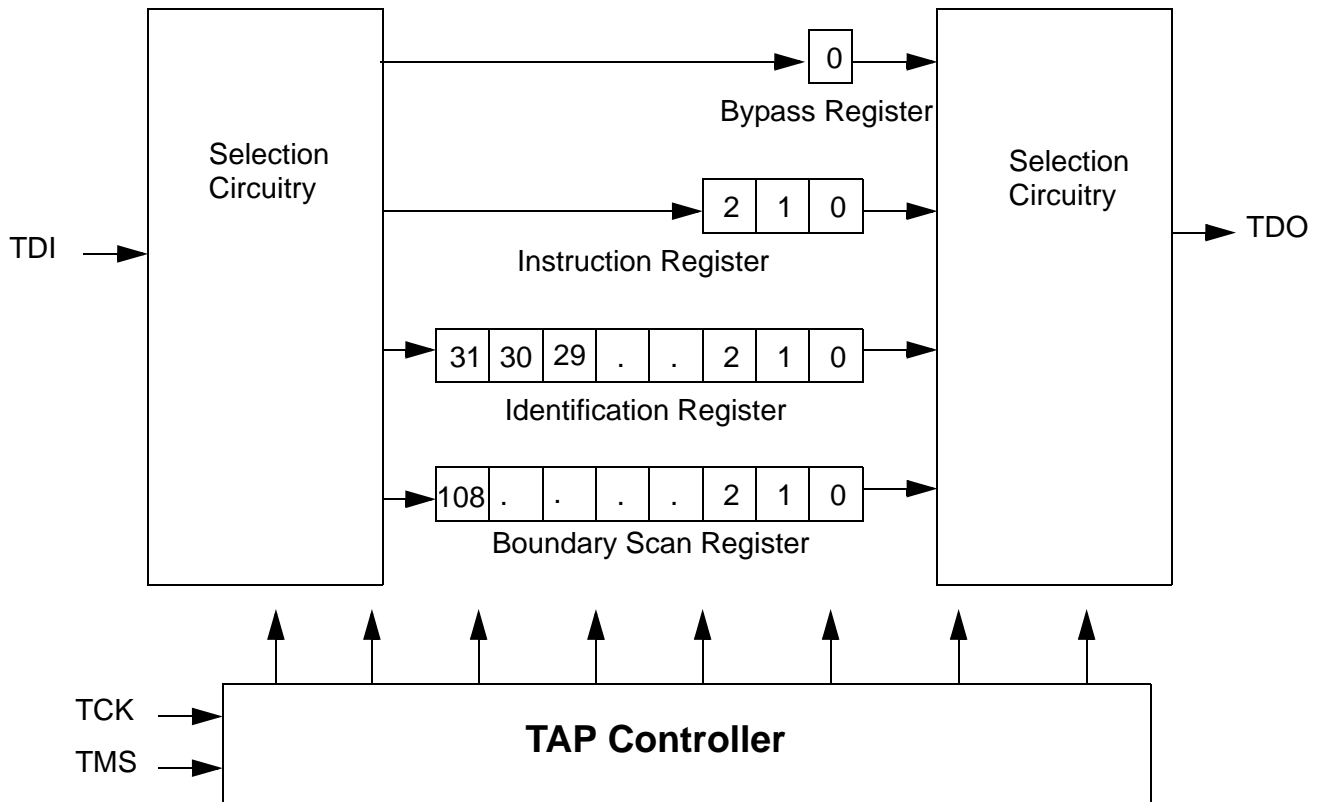

### TAP Electrical Characteristics Over the Operating Range<sup>[10, 15, 17]</sup>

| Parameter        | Description                   | Test Conditions                        | Min.                | Max.                  | Unit |
|------------------|-------------------------------|--|---------------------|-----------------------|------|
| V <sub>OH1</sub> | Output HIGH Voltage           | I <sub>OH</sub> = -2.0 mA              | 1.4                 |                       | V    |
| V <sub>OH2</sub> | Output HIGH Voltage           | I <sub>OH</sub> = -100 μA              | 1.6                 |                       | V    |
| V <sub>OL1</sub> | Output LOW Voltage            | I <sub>OL</sub> = 2.0 mA               |                     | 0.4                   | V    |
| V <sub>OL2</sub> | Output LOW Voltage            | I <sub>OL</sub> = 100 μA               |                     | 0.2                   | V    |
| V <sub>IH</sub>  | Input HIGH Voltage            |  | 0.65V <sub>DD</sub> | V <sub>DD</sub> + 0.3 | V    |
| V <sub>IL</sub>  | Input LOW Voltage             |  | -0.3                | 0.35V <sub>DD</sub>   | V    |
| I <sub>X</sub>   | Input and Output Load Current | GND ≤ V <sub>I</sub> ≤ V <sub>DD</sub> | -5                  | 5                     | μA   |

### TAP AC Switching Characteristics Over the Operating Range<sup>[11, 12]</sup>

| Parameter           | Description                  | Min. | Max. | Unit |
|---------------------|------------------------------|------|------|------|
| t <sub>TCYC</sub>   | TCK Clock Cycle Time         | 50   |      | ns   |
| t <sub>TF</sub>     | TCK Clock Frequency          |      | 20   | MHz  |
| t <sub>TH</sub>     | TCK Clock HIGH               | 20   |      | ns   |
| t <sub>TL</sub>     | TCK Clock LOW                | 20   |      | ns   |
| <b>Set-up Times</b> |                              |      |      |      |
| t <sub>TMSS</sub>   | TMS Set-up to TCK Clock Rise | 5    |      | ns   |
| t <sub>TDIS</sub>   | TDI Set-up to TCK Clock Rise | 5    |      | ns   |
| t <sub>CS</sub>     | Capture Set-up to TCK Rise   | 5    |      | ns   |

**Notes:**

- 10. These characteristics pertain to the TAP inputs (TMS, TCK, TDI and TDO). Parallel load levels are specified in the Electrical Characteristics table.
- 11. t<sub>CS</sub> and t<sub>CH</sub> refer to the set-up and hold time requirements of latching data from the boundary scan register.
- 12. Test conditions are specified using the load in TAP AC test conditions. t<sub>R</sub>/t<sub>F</sub> = 1 ns.

**TAP AC Switching Characteristics** Over the Operating Range<sup>[11, 12]</sup> (continued)

| Parameter           | Description                   | Min. | Max. | Unit |
|---------------------|-------------------------------|------|------|------|
| <b>Hold Times</b>   |                               |      |      |      |
| $t_{TMSH}$          | TMS Hold after TCK Clock Rise | 5    |      | ns   |
| $t_{TDIH}$          | TDI Hold after Clock Rise     | 5    |      | ns   |
| $t_{CH}$            | Capture Hold after Clock Rise | 5    |      | ns   |
| <b>Output Times</b> |                               |      |      |      |
| $t_{TDOV}$          | TCK Clock LOW to TDO Valid    |      | 10   | ns   |
| $t_{TDOX}$          | TCK Clock LOW to TDO Invalid  | 0    |      | ns   |

**TAP Timing and Test Conditions**<sup>[12]</sup>

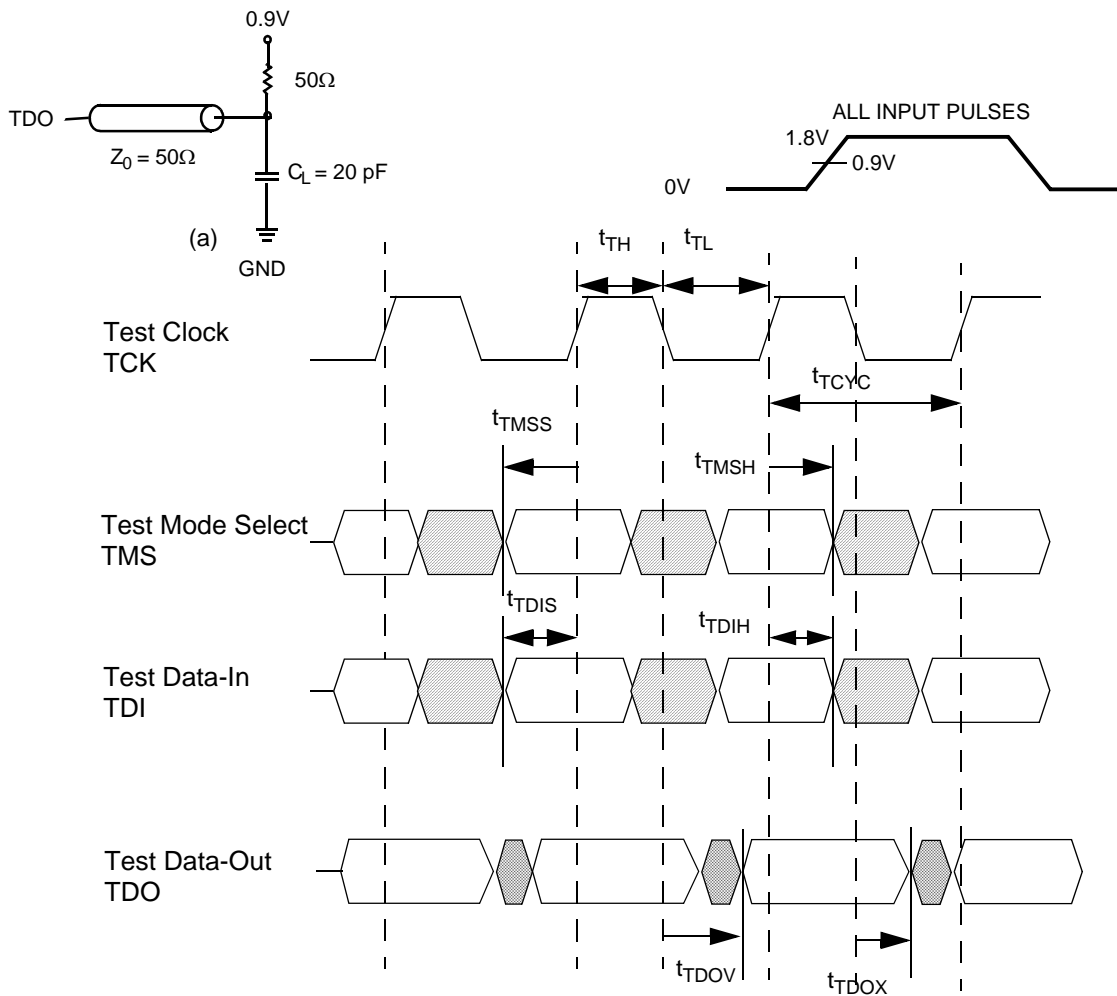

### Identification Register Definitions

| Instruction Field         | Value             |                   |                   |                   | Description                                  |
|---------------------------|-------------------|-------------------|-------------------|-------------------|--|
|                           | CY7C1417AV18      | CY7C1428AV18      | CY7C1419AV18      | CY7C1421AV18      |  |
| Revision Number (31:29)   | 000               | 000               | 000               | 000               | Version number.                              |
| Cypress Device ID (28:12) | 11010100011000111 | 11010100011001111 | 11010100011010111 | 11010100011100111 | Defines the type of SRAM.                    |
| Cypress JEDEC ID (11:1)   | 00000110100       | 00000110100       | 00000110100       | 00000110100       | Allows unique identification of SRAM vendor. |
| ID Register Presence (0)  | 1                 | 1                 | 1                 | 1                 | Indicate the presence of an ID register.     |

### Scan Register Sizes

| Register Name | Bit Size |
|---------------|----------|
| Instruction   | 3        |
| Bypass        | 1        |
| ID            | 32       |
| Boundary Scan | 109      |

### Instruction Codes

| Instruction    | Code | Description  |
|----------------|------|--|
| EXTTEST        | 000  | Captures the Input/Output ring contents.   |
| IDCODE         | 001  | Loads the ID register with the vendor ID code and places the register between TDI and TDO. This operation does not affect SRAM operation.    |
| SAMPLE Z       | 010  | Captures the Input/Output contents. Places the boundary scan register between TDI and TDO. Forces all SRAM output drivers to a High-Z state. |
| RESERVED       | 011  | Do Not Use: This instruction is reserved for future use.   |
| SAMPLE/PRELOAD | 100  | Captures the Input/Output ring contents. Places the boundary scan register between TDI and TDO. Does not affect the SRAM operation.          |
| RESERVED       | 101  | Do Not Use: This instruction is reserved for future use.   |
| RESERVED       | 110  | Do Not Use: This instruction is reserved for future use.   |
| BYPASS         | 111  | Places the bypass register between TDI and TDO. This operation does not affect SRAM operation.   |



**Boundary Scan Order**

| Bit # | Bump ID | Bit # | Bump ID | Bit # | Bump ID | Bit # | Bump ID  |
|-------|---------|-------|---------|-------|---------|-------|----------|
| 0     | 6R      | 28    | 10G     | 56    | 6A      | 84    | 1J       |
| 1     | 6P      | 29    | 9G      | 57    | 5B      | 85    | 2J       |
| 2     | 6N      | 30    | 11F     | 58    | 5A      | 86    | 3K       |
| 3     | 7P      | 31    | 11G     | 59    | 4A      | 87    | 3J       |
| 4     | 7N      | 32    | 9F      | 60    | 5C      | 88    | 2K       |
| 5     | 7R      | 33    | 10F     | 61    | 4B      | 89    | 1K       |
| 6     | 8R      | 34    | 11E     | 62    | 3A      | 90    | 2L       |
| 7     | 8P      | 35    | 10E     | 63    | 2A      | 91    | 3L       |
| 8     | 9R      | 36    | 10D     | 64    | 1A      | 92    | 1M       |
| 9     | 11P     | 37    | 9E      | 65    | 2B      | 93    | 1L       |
| 10    | 10P     | 38    | 10C     | 66    | 3B      | 94    | 3N       |
| 11    | 10N     | 39    | 11D     | 67    | 1C      | 95    | 3M       |
| 12    | 9P      | 40    | 9C      | 68    | 1B      | 96    | 1N       |
| 13    | 10M     | 41    | 9D      | 69    | 3D      | 97    | 2M       |
| 14    | 11N     | 42    | 11B     | 70    | 3C      | 98    | 3P       |
| 15    | 9M      | 43    | 11C     | 71    | 1D      | 99    | 2N       |
| 16    | 9N      | 44    | 9B      | 72    | 2C      | 100   | 2P       |
| 17    | 11L     | 45    | 10B     | 73    | 3E      | 101   | 1P       |
| 18    | 11M     | 46    | 11A     | 74    | 2D      | 102   | 3R       |
| 19    | 9L      | 47    | 10A     | 75    | 2E      | 103   | 4R       |
| 20    | 10L     | 48    | 9A      | 76    | 1E      | 104   | 4P       |
| 21    | 11K     | 49    | 8B      | 77    | 2F      | 105   | 5P       |
| 22    | 10K     | 50    | 7C      | 78    | 3F      | 106   | 5N       |
| 23    | 9J      | 51    | 6C      | 79    | 1G      | 107   | 5R       |
| 24    | 9K      | 52    | 8A      | 80    | 1F      | 108   | Internal |
| 25    | 10J     | 53    | 7A      | 81    | 3G      |       |          |
| 26    | 11J     | 54    | 7B      | 82    | 2G      |       |          |
| 27    | 11H     | 55    | 6B      | 83    | 1H      |       |          |

### Power-Up Sequence in DDR-II SRAM<sup>[13, 14]</sup>

DDR-II SRAMs must be powered up and initialized in a predefined manner to prevent undefined operations.

#### Power-Up Sequence

- Apply power and drive  $\overline{\text{DOFF}}$  LOW (All other inputs can be HIGH or LOW)
  - Apply  $V_{DD}$  before  $V_{DDQ}$
  - Apply  $V_{DDQ}$  before  $V_{REF}$  or at the same time as  $V_{REF}$
- After the power and clock (K,  $\overline{K}$ , C,  $\overline{C}$ ) are stable take  $\overline{\text{DOFF}}$  HIGH
- The additional 1024 cycles of clocks are required for the DLL to lock

#### DLL Constraints

- DLL uses either K or C clock as its synchronizing input. The input should have low phase jitter, which is specified as  $t_{KC \text{ Var}}$
- The DLL will function at frequencies down to 80 MHz
- If the input clock is unstable and the DLL is enabled, then the DLL may lock to an incorrect frequency, causing unstable SRAM behavior

#### Power-up Waveforms

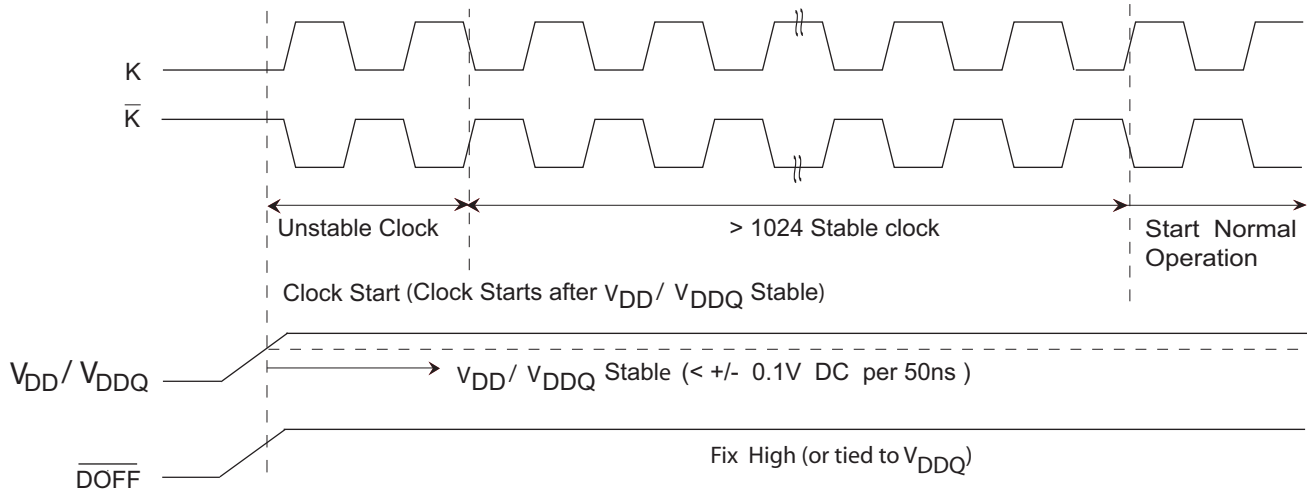

#### Notes:

13. It is recommended that the  $\overline{\text{DOFF}}$  pin be pulled HIGH via a pull up resistor of 1 Kohm.
14. During Power-Up, when the  $\overline{\text{DOFF}}$  is tied HIGH, the DLL gets locked after 1024 cycles of stable clock.



## Maximum Ratings

(Above which the useful life may be impaired.)

Storage Temperature ..... -65°C to +150°C  
 Ambient Temperature with Power Applied .. -55°C to +125°C  
 Supply Voltage on V<sub>DD</sub> Relative to GND..... -0.5V to +2.9V  
 Supply Voltage on V<sub>DDQ</sub> Relative to GND ..... -0.5V to +V<sub>DD</sub>  
 DC Applied to Outputs in High-Z..... -0.5V to V<sub>DDQ</sub> + 0.3V  
 DC Input Voltage<sup>[15]</sup> ..... -0.5V to V<sub>DDQ</sub> + 0.3V

Current into Outputs (LOW)..... 20 mA  
 Static Discharge Voltage (MIL-STD-883, M 3015)... > 2001V  
 Latch-up Current..... > 200 mA

## Operating Range

| Range | Ambient Temperature | V <sub>DD</sub> <sup>[16]</sup> | V <sub>DDQ</sub> <sup>[16]</sup> |
|-------|---------------------|---------------------------------|----------------------------------|
| Com'l | 0°C to +70°C        | 1.8 ± 0.1V                      | 1.4V to V <sub>DD</sub>          |
| Ind'l | -40°C to +85°C      |                                 |                                  |

## Electrical Characteristics Over the Operating Range<sup>[17]</sup>

### DC Electrical Characteristics Over the Operating Range

| Parameter            | Description                             | Test Conditions  | Min.                       | Typ. | Max.                       | Unit |
|----------------------|---|--|----------------------------|------|----------------------------|------|
| V <sub>DD</sub>      | Power Supply Voltage                    |  | 1.7                        | 1.8  | 1.9                        | V    |
| V <sub>DDQ</sub>     | I/O Supply Voltage                      |  | 1.4                        | 1.5  | V <sub>DD</sub>            | V    |
| V <sub>OH</sub>      | Output HIGH Voltage                     | Note 18  | V <sub>DDQ</sub> /2 - 0.12 |      | V <sub>DDQ</sub> /2 + 0.12 | V    |
| V <sub>OL</sub>      | Output LOW Voltage                      | Note 19  | V <sub>DDQ</sub> /2 - 0.12 |      | V <sub>DDQ</sub> /2 + 0.12 | V    |
| V <sub>OH(LOW)</sub> | Output HIGH Voltage                     | I <sub>OH</sub> = -0.1 mA, Nominal Impedance   | V <sub>DDQ</sub> - 0.2     |      | V <sub>DDQ</sub>           | V    |
| V <sub>OL(LOW)</sub> | Output LOW Voltage                      | I <sub>OL</sub> = 0.1 mA, Nominal Impedance  | V <sub>SS</sub>            |      | 0.2                        | V    |
| V <sub>IH</sub>      | Input HIGH Voltage <sup>[15]</sup>      |  | V <sub>REF</sub> + 0.1     |      | V <sub>DDQ</sub> + 0.3     | V    |
| V <sub>IL</sub>      | Input LOW Voltage <sup>[15]</sup>       |  | -0.3                       |      | V <sub>REF</sub> - 0.1     | V    |
| I <sub>X</sub>       | Input Leakage Current                   | GND ≤ V <sub>I</sub> ≤ V <sub>DDQ</sub>  | -5                         |      | 5                          | μA   |
| I <sub>OZ</sub>      | Output Leakage Current                  | GND ≤ V <sub>I</sub> ≤ V <sub>DDQ</sub> , Output Disabled  | -5                         |      | 5                          | μA   |
| V <sub>REF</sub>     | Input Reference Voltage <sup>[20]</sup> | Typical Value = 0.75V  | 0.68                       | 0.75 | 0.95                       | V    |
| I <sub>DD</sub>      | V <sub>DD</sub> Operating Supply        | V <sub>DD</sub> = Max.,<br>I <sub>OUT</sub> = 0 mA,<br>f = f <sub>MAX</sub> = 1/t <sub>CYC</sub>   | 167 MHz                    |      | 500                        | mA   |
|                      |   |  | 200 MHz                    |      | 600                        | mA   |
|                      |   |  | 250 MHz                    |      | 700                        | mA   |
|                      |   |  | 278 MHz                    |      | 775                        | mA   |
|                      |   |  | 300 MHz                    |      | 825                        | mA   |
| I <sub>SB1</sub>     | Automatic Power-down Current            | Max. V <sub>DD</sub> ,<br>Both ports Deselected,<br>V <sub>IN</sub> ≥ V <sub>IH</sub> or V <sub>IN</sub> ≤ V <sub>IL</sub> ,<br>f = f <sub>MAX</sub> = 1/t <sub>CYC</sub> ,<br>Inputs Static | 167 MHz                    |      | 220                        | mA   |
|                      |   |  | 200 MHz                    |      | 230                        | mA   |
|                      |   |  | 250 MHz                    |      | 250                        | mA   |
|                      |   |  | 278 MHz                    |      | 260                        | mA   |
|                      |   |  | 300 MHz                    |      | 270                        | mA   |

### AC Input Requirements Over the Operating Range

| Parameter       | Description        | Test Conditions | Min.                   | Typ. | Max.                   | Unit |
|-----------------|--------------------|-----------------|------------------------|------|------------------------|------|
| V <sub>IH</sub> | Input HIGH Voltage |                 | V <sub>REF</sub> + 0.2 | -    | -                      | V    |
| V <sub>IL</sub> | Input LOW Voltage  |                 | -                      | -    | V <sub>REF</sub> - 0.2 | V    |

#### Notes:

15. Overshoot: V<sub>IH(AC)</sub> ≤ V<sub>DD</sub> + 0.85V (Pulse width less than t<sub>TCYC</sub>/2); Undershoot V<sub>IL(AC)</sub> > -1.5V (Pulse width less than t<sub>TCYC</sub>/2).
16. Power-up: Assumes a linear ramp from 0V to V<sub>DD</sub> (Min.) within 200 ms. During this time V<sub>IH</sub> < V<sub>DD</sub> and V<sub>DDQ</sub> ≤ V<sub>DD</sub>.
17. All voltage referenced to ground.
18. Outputs are impedance controlled. I<sub>OH</sub> = -(V<sub>DDQ</sub>/2)/(RQ/5) for values of 175Ω ≤ RQ ≤ 350Ω.
19. Outputs are impedance controlled. I<sub>OL</sub> = (V<sub>DDQ</sub>/2)/(RQ/5) for values of 175Ω ≤ RQ ≤ 350Ω.
20. V<sub>REF</sub> (Min.) = 0.68V or 0.46V<sub>DDQ</sub>, whichever is larger, V<sub>REF</sub> (Max.) = 0.95V or 0.54V<sub>DDQ</sub>, whichever is smaller.



### Capacitance<sup>[21]</sup>

| Parameter        | Description             | Test Conditions   | Max. | Unit |
|------------------|-------------------------|---|------|------|
| C <sub>IN</sub>  | Input Capacitance       | T <sub>A</sub> = 25°C, f = 1 MHz, V <sub>DD</sub> = 1.8V, V <sub>DDQ</sub> = 1.5V | 5    | pF   |
| C <sub>CLK</sub> | Clock Input Capacitance |   | 4    | pF   |
| C <sub>O</sub>   | Output Capacitance      |   | 5    | pF   |

### Thermal Resistance<sup>[21]</sup>

| Parameter       | Description                              | Test Conditions  | 165 FBGA Package | Unit |
|-----------------|--|--|------------------|------|
| Θ <sub>JA</sub> | Thermal Resistance (Junction to Ambient) | Test conditions follow standard test methods and procedures for measuring thermal impedance, per EIA/JESD51. | 17.2             | °C/W |
| Θ <sub>JC</sub> | Thermal Resistance (Junction to Case)    |  | 3.2              | °C/W |

### AC Test Loads and Waveforms

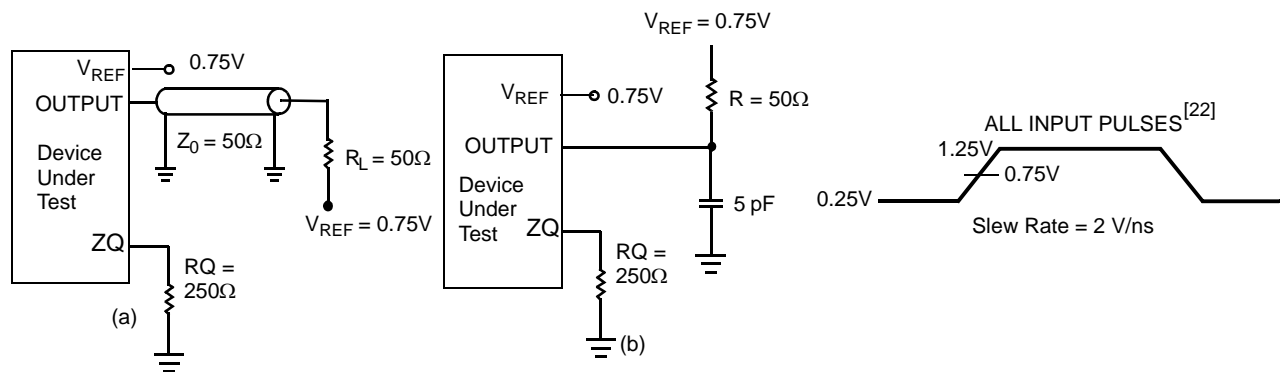

#### Notes:

21. Tested initially and after any design or process change that may affect these parameters.

22. Unless otherwise noted, test conditions assume signal transition time of 2V/ns, timing reference levels of 0.75V, V<sub>REF</sub> = 0.75V, R<sub>Q</sub> = 250Ω, V<sub>DDQ</sub> = 1.5V, input pulse levels of 0.25V to 1.25V, and output loading of the specified I<sub>OL</sub>/I<sub>OH</sub> and load capacitance shown in (a) of AC Test Loads.

**Switching Characteristics** Over the Operating Range [22, 23]

| Cypress Parameter                    | Consortium Parameter                 | Description   | 300 MHz |      | 278 MHz |      | 250 MHz |      | 200 MHz |      | 167 MHz |      | Unit |
|--------------------------------------|--------------------------------------|---|---------|------|---------|------|---------|------|---------|------|---------|------|------|
|                                      |                                      |   | Min.    | Max. | Min.    | Max. | Min.    | Max. | Min.    | Max. | Min.    | Max. |      |
| t <sub>POWER</sub>                   |                                      | V <sub>DD</sub> (Typical) to the first Access <sup>[24]</sup>   | 1       |      | 1       |      | 1       |      | 1       |      | 1       |      | ms   |
| t <sub>CYC</sub>                     | t <sub>KHKH</sub>                    | K Clock and C Clock Cycle Time  | 3.30    | 5.25 | 3.30    | 5.25 | 4.0     | 6.3  | 5.0     | 7.9  | 6.0     | 8.4  | ns   |
| t <sub>KH</sub>                      | t <sub>KHKL</sub>                    | Input Clock (K/ $\bar{K}$ and C/C) HIGH   | 1.32    | –    | 1.32    | –    | 1.6     | –    | 2.0     | –    | 2.4     | –    | ns   |
| t <sub>KL</sub>                      | t <sub>KLKH</sub>                    | Input Clock (K/ $\bar{K}$ and C/C) LOW  | 1.32    |      | 1.32    |      | 1.6     | –    | 2.0     | –    | 2.4     | –    | ns   |
| t <sub>KH<math>\bar{K}</math>H</sub> | t <sub>KH<math>\bar{K}</math>H</sub> | K Clock Rise to $\bar{K}$ Clock Rise and C to $\bar{C}$ Rise (rising edge to rising edge)   | 1.49    | –    | 1.49    | –    | 1.8     | –    | 2.2     | –    | 2.7     | –    | ns   |
| t <sub>KHCH</sub>                    | t <sub>KHCH</sub>                    | K/ $\bar{K}$ Clock Rise to C/ $\bar{C}$ Clock Rise (rising edge to rising edge)   | 0.0     | 1.45 | 0.0     | 1.45 | 0.0     | 1.8  | 0.0     | 2.2  | 0.0     | 2.7  | ns   |
| <b>Set-up Times</b>                  |                                      |   |         |      |         |      |         |      |         |      |         |      |      |
| t <sub>SA</sub>                      | t <sub>AVKH</sub>                    | Address Set-up to K Clock Rise  | 0.4     | –    | 0.4     | –    | 0.5     | –    | 0.6     | –    | 0.7     | –    | ns   |
| t <sub>SC</sub>                      | t <sub>IVKH</sub>                    | Control Set-up to K Clock Rise (LD, R/W)  | 0.4     | –    | 0.4     | –    | 0.5     | –    | 0.6     | –    | 0.7     | –    | ns   |
| t <sub>SCDDR</sub>                   | t <sub>IVKH</sub>                    | Double Data Rate Control Set-up to Clock (K, $\bar{K}$ ) Rise (BWS <sub>0</sub> , BWS <sub>1</sub> , BWS <sub>2</sub> , BWS <sub>3</sub> )  | 0.3     | –    | 0.3     | –    | 0.35    | –    | 0.4     | –    | 0.5     | –    | ns   |
| t <sub>SD</sub> <sup>[25]</sup>      | t <sub>DVKH</sub>                    | D <sub>[X:0]</sub> Set-up to Clock (K/ $\bar{K}$ ) Rise   | 0.3     | –    | 0.3     | –    | 0.35    | –    | 0.4     | –    | 0.5     | –    | ns   |
| <b>Hold Times</b>                    |                                      |   |         |      |         |      |         |      |         |      |         |      |      |
| t <sub>HA</sub>                      | t <sub>KHAX</sub>                    | Address Hold after K Clock Rise   | 0.4     | –    | 0.4     | –    | 0.5     | –    | 0.6     | –    | 0.7     | –    | ns   |
| t <sub>HC</sub>                      | t <sub>KHIX</sub>                    | Control Hold after K Clock Rise (LD, R/W)   | 0.4     | –    | 0.4     | –    | 0.5     | –    | 0.6     | –    | 0.7     | –    | ns   |
| t <sub>HCDDR</sub>                   | t <sub>KHIX</sub>                    | Double Data Rate Control Hold after Clock (K, $\bar{K}$ ) Rise (BWS <sub>0</sub> , BWS <sub>1</sub> , BWS <sub>2</sub> , BWS <sub>3</sub> ) | 0.30    | –    | 0.30    | –    | 0.35    | –    | 0.4     | –    | 0.5     | –    | ns   |
| t <sub>HD</sub>                      | t <sub>KHDX</sub>                    | D <sub>[X:0]</sub> Hold after Clock (K/ $\bar{K}$ ) Rise  | 0.30    | –    | 0.30    | –    | 0.35    | –    | 0.4     | –    | 0.5     | –    | ns   |

**Notes:**

23. All devices can operate at clock frequencies as low as 119 MHz. When a part with a maximum frequency above 133 MHz is operating at a lower clock frequency, it requires the input timings of the frequency range in which it is being operated and will output data with the output timings of that frequency range.

24. This part has a voltage regulator internally; t<sub>POWER</sub> is the time that the power needs to be supplied above V<sub>DD</sub> minimum initially before a read or write operation can be initiated.

25. For DQ2 data signal on CY7C1428AV18 device, t<sub>SD</sub> is 0.5 ns for 200 MHz, 250 MHz, 278 MHz and 300 MHz frequencies.

**Switching Characteristics** Over the Operating Range (continued)<sup>[22, 23]</sup>

| Cypress Parameter     | Consortium Parameter  | Description  | 300 MHz |      | 278 MHz |      | 250 MHz |      | 200 MHz |      | 167 MHz |      | Unit   |
|-----------------------|-----------------------|--|---------|------|---------|------|---------|------|---------|------|---------|------|--------|
|                       |                       |  | Min.    | Max. | Min.    | Max. | Min.    | Max. | Min.    | Max. | Min.    | Max. |        |
| <b>Output Times</b>   |                       |  |         |      |         |      |         |      |         |      |         |      |        |
| t <sub>CO</sub>       | t <sub>CHQV</sub>     | C/ $\bar{C}$ Clock Rise (or K/ $\bar{K}$ in single clock mode) to Data Valid | –       | 0.45 | –       | 0.45 | –       | 0.45 | –       | 0.45 | –       | 0.50 | ns     |
| t <sub>DOH</sub>      | t <sub>CHQX</sub>     | Data Output Hold after Output C/ $\bar{C}$ Clock Rise (Active to Active)     | –0.45   | –    | –0.45   | –    | –0.45   | –    | –0.45   | –    | –0.50   | –    | ns     |
| t <sub>CCQO</sub>     | t <sub>CHCQV</sub>    | C/ $\bar{C}$ Clock Rise to Echo Clock Valid                                  | –       | 0.45 | –       | 0.45 | –       | 0.45 | –       | 0.45 | –       | 0.50 | ns     |
| t <sub>CQOH</sub>     | t <sub>CHCQX</sub>    | Echo Clock Hold after C/ $\bar{C}$ Clock Rise                                | –0.45   | –    | –0.45   | –    | –0.45   | –    | –0.45   | –    | –0.50   | –    | ns     |
| t <sub>CQD</sub>      | t <sub>CQHQV</sub>    | Echo Clock High to Data Valid  | –       | 0.27 | –       | 0.27 | –       | 0.30 | –       | 0.35 | –       | 0.40 | ns     |
| t <sub>CQDOH</sub>    | t <sub>CQHQX</sub>    | Echo Clock High to Data Invalid  | –0.27   | –    | –0.27   | –    | –0.30   | –    | –0.35   | –    | –0.40   | –    | ns     |
| t <sub>CHZ</sub>      | t <sub>CHQZ</sub>     | Clock (C/ $\bar{C}$ ) Rise to High-Z (Active to High-Z) <sup>[26, 27]</sup>  | –       | 0.45 | –       | 0.45 | –       | 0.45 | –       | 0.45 | –       | 0.50 | ns     |
| t <sub>CLZ</sub>      | t <sub>CHQX1</sub>    | Clock (C/ $\bar{C}$ ) Rise to Low-Z <sup>[26, 27]</sup>                      | –0.45   | –    | –0.45   | –    | –0.45   | –    | –0.45   | –    | –0.50   | –    | ns     |
| <b>DLL Timing</b>     |                       |  |         |      |         |      |         |      |         |      |         |      |        |
| t <sub>KC Var</sub>   | t <sub>KC Var</sub>   | Clock Phase Jitter   | –       | 0.20 | –       | 0.20 | –       | 0.20 | –       | 0.20 | –       | 0.20 | ns     |
| t <sub>KC lock</sub>  | t <sub>KC lock</sub>  | DLL Lock Time (K, C)   | 1024    | –    | 1024    | –    | 1024    | –    | 1024    | –    | 1024    | –    | Cycles |
| t <sub>KC Reset</sub> | t <sub>KC Reset</sub> | K Static to DLL Reset  | 30      |      | 30      |      | 30      |      | 30      |      | 30      |      | ns     |

**Notes:**

26. t<sub>CHZ</sub>, t<sub>CLZ</sub>, are specified with a load capacitance of 5 pF as in (b) of AC Test Loads. Transition is measured  $\pm 100$  mV from steady-state voltage.  
27. At any given voltage and temperature t<sub>CHZ</sub> is less than t<sub>CLZ</sub> and t<sub>CHZ</sub> less than t<sub>CO</sub>.

Switching Waveforms [28, 29, 30]

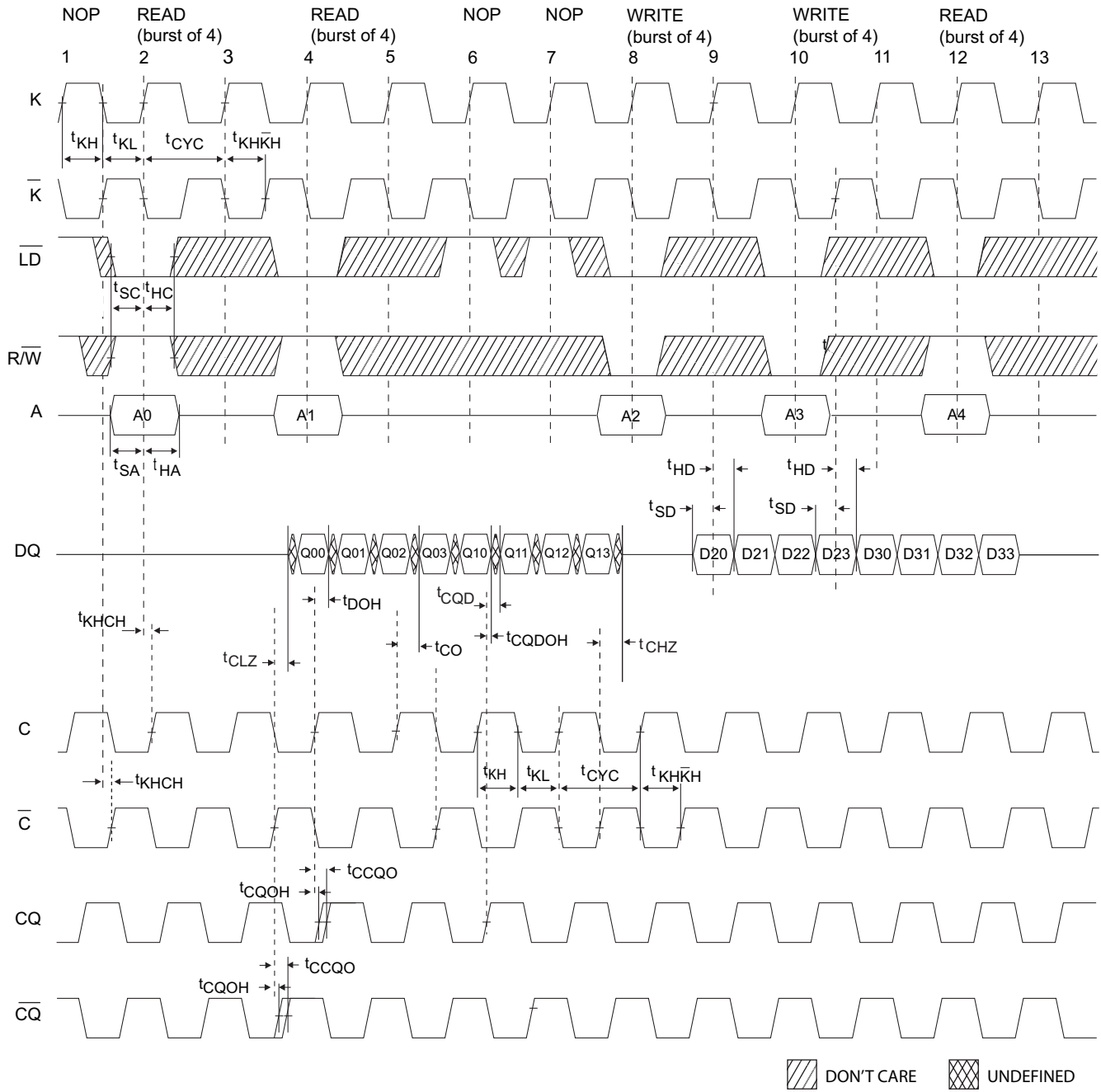

Notes:

28. Q00 refers to output from address A0. Q01 refers to output from the next internal burst address following A0, i.e., A0 + 1.

29. Output are disabled (High-Z) one clock cycle after a NOP.

30. In this example, if address A2 = A1, then data Q20 = D10 and Q21 = D11. Write data is forwarded immediately as read results. This note applies to the whole diagram.



**CY7C1417AV18**  
**CY7C1428AV18**  
**CY7C1419AV18**  
**CY7C1421AV18**

## Ordering Information

Not all of the speed, package and temperature ranges are available. Please contact your local sales representative or visit [www.cypress.com](http://www.cypress.com) for actual products offered.

| Speed (MHz)          | Ordering Code        | Package Diagram      | Package Type   | Operating Range |  |            |
|----------------------|----------------------|----------------------|--|-----------------|--|------------|
| 167                  | CY7C1417AV18-167BZC  | 51-85195             | 165-ball Fine Pitch Ball Grid Array (15 x 17 x 1.4 mm)           | Commercial      |  |            |
|                      | CY7C1428AV18-167BZC  |                      |  |                 |  |            |
|                      | CY7C1419AV18-167BZC  |                      |  |                 |  |            |
|                      | CY7C1421AV18-167BZC  |                      |  |                 |  |            |
|                      | CY7C1417AV18-167BZXC | 51-85195             | 165-ball Fine Pitch Ball Grid Array (15 x 17 x 1.4 mm) Lead-Free |                 |  |            |
|                      | CY7C1428AV18-167BZXC |                      |  |                 |  |            |
|                      | CY7C1419AV18-167BZXC |                      |  |                 |  |            |
|                      | CY7C1421AV18-167BZXC |                      |  |                 |  |            |
|                      | 167                  | CY7C1417AV18-167BZI  | 51-85195   |                 | 165-ball Fine Pitch Ball Grid Array (15 x 17 x 1.4 mm)           | Industrial |
|                      |                      | CY7C1428AV18-167BZI  |  |                 |  |            |
|                      |                      | CY7C1419AV18-167BZI  |  |                 |  |            |
|                      |                      | CY7C1421AV18-167BZI  |  |                 |  |            |
| CY7C1417AV18-167BZXI |                      | 51-85195             | 165-ball Fine Pitch Ball Grid Array (15 x 17 x 1.4 mm) Lead-Free |                 |  |            |
| CY7C1428AV18-167BZXI |                      |                      |  |                 |  |            |
| CY7C1419AV18-167BZXI |                      |                      |  |                 |  |            |
| CY7C1421AV18-167BZXI |                      |                      |  |                 |  |            |
| 200                  | CY7C1417AV18-200BZC  | 51-85195             | 165-ball Fine Pitch Ball Grid Array (15 x 17 x 1.4 mm)           | Commercial      |  |            |
|                      | CY7C1428AV18-200BZC  |                      |  |                 |  |            |
|                      | CY7C1419AV18-200BZC  |                      |  |                 |  |            |
|                      | CY7C1421AV18-200BZC  |                      |  |                 |  |            |
|                      | CY7C1417AV18-200BZXC | 51-85195             | 165-ball Fine Pitch Ball Grid Array (15 x 17 x 1.4 mm) Lead-Free |                 |  |            |
|                      | CY7C1428AV18-200BZXC |                      |  |                 |  |            |
|                      | CY7C1419AV18-200BZXC |                      |  |                 |  |            |
|                      | CY7C1421AV18-200BZXC |                      |  |                 |  |            |
|                      | 200                  | CY7C1417AV18-200BZI  | 51-85195   |                 | 165-ball Fine Pitch Ball Grid Array (15 x 17 x 1.4 mm)           | Industrial |
|                      |                      | CY7C1428AV18-200BZI  |  |                 |  |            |
|                      |                      | CY7C1419AV18-200BZI  |  |                 |  |            |
|                      |                      | CY7C1421AV18-200BZI  |  |                 |  |            |
|                      |                      | CY7C1417AV18-200BZXI | 51-85195   |                 | 165-ball Fine Pitch Ball Grid Array (15 x 17 x 1.4 mm) Lead-Free |            |
|                      |                      | CY7C1428AV18-200BZXI |  |                 |  |            |
|                      |                      | CY7C1419AV18-200BZXI |  |                 |  |            |
|                      |                      | CY7C1421AV18-200BZXI |  |                 |  |            |
| 250                  | CY7C1417AV18-250BZC  | 51-85195             | 165-ball Fine Pitch Ball Grid Array (15 x 17 x 1.4 mm)           | Commercial      |  |            |
|                      | CY7C1428AV18-250BZC  |                      |  |                 |  |            |
|                      | CY7C1419AV18-250BZC  |                      |  |                 |  |            |
|                      | CY7C1421AV18-250BZC  |                      |  |                 |  |            |
|                      | CY7C1417AV18-250BZXC | 51-85195             | 165-ball Fine Pitch Ball Grid Array (15 x 17 x 1.4 mm) Lead-Free |                 |  |            |
|                      | CY7C1428AV18-250BZXC |                      |  |                 |  |            |
|                      | CY7C1419AV18-250BZXC |                      |  |                 |  |            |
|                      | CY7C1421AV18-250BZXC |                      |  |                 |  |            |



**CY7C1417AV18**  
**CY7C1428AV18**  
**CY7C1419AV18**  
**CY7C1421AV18**

**Ordering Information** (continued)

Not all of the speed, package and temperature ranges are available. Please contact your local sales representative or visit [www.cypress.com](http://www.cypress.com) for actual products offered.

| Speed (MHz) | Ordering Code        | Package Diagram | Package Type   | Operating Range |            |
|-------------|----------------------|-----------------|--|-----------------|------------|
| 250         | CY7C1417AV18-250BZI  | 51-85195        | 165-ball Fine Pitch Ball Grid Array (15 x 17 x 1.4 mm)           | Industrial      |            |
|             | CY7C1428AV18-250BZI  |                 |  |                 |            |
|             | CY7C1419AV18-250BZI  |                 |  |                 |            |
|             | CY7C1421AV18-250BZI  |                 |  |                 |            |
|             | CY7C1417AV18-250BZXI | 51-85195        | 165-ball Fine Pitch Ball Grid Array (15 x 17 x 1.4 mm) Lead-Free |                 |            |
|             | CY7C1428AV18-250BZXI |                 |  |                 |            |
|             | CY7C1419AV18-250BZXI |                 |  |                 |            |
|             | CY7C1421AV18-250BZXI |                 |  |                 |            |
| 278         | CY7C1417AV18-278BZC  | 51-85195        | 165-ball Fine Pitch Ball Grid Array (15 x 17 x 1.4 mm)           | Commercial      |            |
|             | CY7C1428AV18-278BZC  |                 |  |                 |            |
|             | CY7C1419AV18-278BZC  |                 |  |                 |            |
|             | CY7C1421AV18-278BZC  |                 |  |                 |            |
|             | CY7C1417AV18-278BZXC | 51-85195        | 165-ball Fine Pitch Ball Grid Array (15 x 17 x 1.4 mm) Lead-Free |                 |            |
|             | CY7C1428AV18-278BZXC |                 |  |                 |            |
|             | CY7C1419AV18-278BZXC |                 |  |                 |            |
|             | CY7C1421AV18-278BZXC |                 |  |                 |            |
|             | CY7C1417AV18-278BZI  | 51-85195        | 165-ball Fine Pitch Ball Grid Array (15 x 17 x 1.4 mm)           |                 | Industrial |
|             | CY7C1428AV18-278BZI  |                 |  |                 |            |
|             | CY7C1419AV18-278BZI  |                 |  |                 |            |
|             | CY7C1421AV18-278BZI  |                 |  |                 |            |
|             | CY7C1417AV18-278BZXI | 51-85195        | 165-ball Fine Pitch Ball Grid Array (15 x 17 x 1.4 mm) Lead-Free |                 |            |
|             | CY7C1428AV18-278BZXI |                 |  |                 |            |
|             | CY7C1419AV18-278BZXI |                 |  |                 |            |
|             | CY7C1421AV18-278BZXI |                 |  |                 |            |
| 300         | CY7C1417AV18-300BZC  | 51-85195        | 165-ball Fine Pitch Ball Grid Array (15 x 17 x 1.4 mm)           | Commercial      |            |
|             | CY7C1428AV18-300BZC  |                 |  |                 |            |
|             | CY7C1419AV18-300BZC  |                 |  |                 |            |
|             | CY7C1421AV18-300BZC  |                 |  |                 |            |
|             | CY7C1417AV18-300BZXC | 51-85195        | 165-ball Fine Pitch Ball Grid Array (15 x 17 x 1.4 mm) Lead-Free |                 |            |
|             | CY7C1428AV18-300BZXC |                 |  |                 |            |
|             | CY7C1419AV18-300BZXC |                 |  |                 |            |
|             | CY7C1421AV18-300BZXC |                 |  |                 |            |
|             | CY7C1417AV18-300BZI  | 51-85195        | 165-ball Fine Pitch Ball Grid Array (15 x 17 x 1.4 mm)           |                 | Industrial |
|             | CY7C1428AV18-300BZI  |                 |  |                 |            |
|             | CY7C1419AV18-300BZI  |                 |  |                 |            |
|             | CY7C1421AV18-300BZI  |                 |  |                 |            |
|             | CY7C1417AV18-300BZXI | 51-85195        | 165-ball Fine Pitch Ball Grid Array (15 x 17 x 1.4 mm) Lead-Free |                 |            |
|             | CY7C1428AV18-300BZXI |                 |  |                 |            |
|             | CY7C1419AV18-300BZXI |                 |  |                 |            |
|             | CY7C1421AV18-300BZXI |                 |  |                 |            |



## Package Diagram

### 165-ball FBGA (15 x 17 x 1.40 mm) (51-85195)

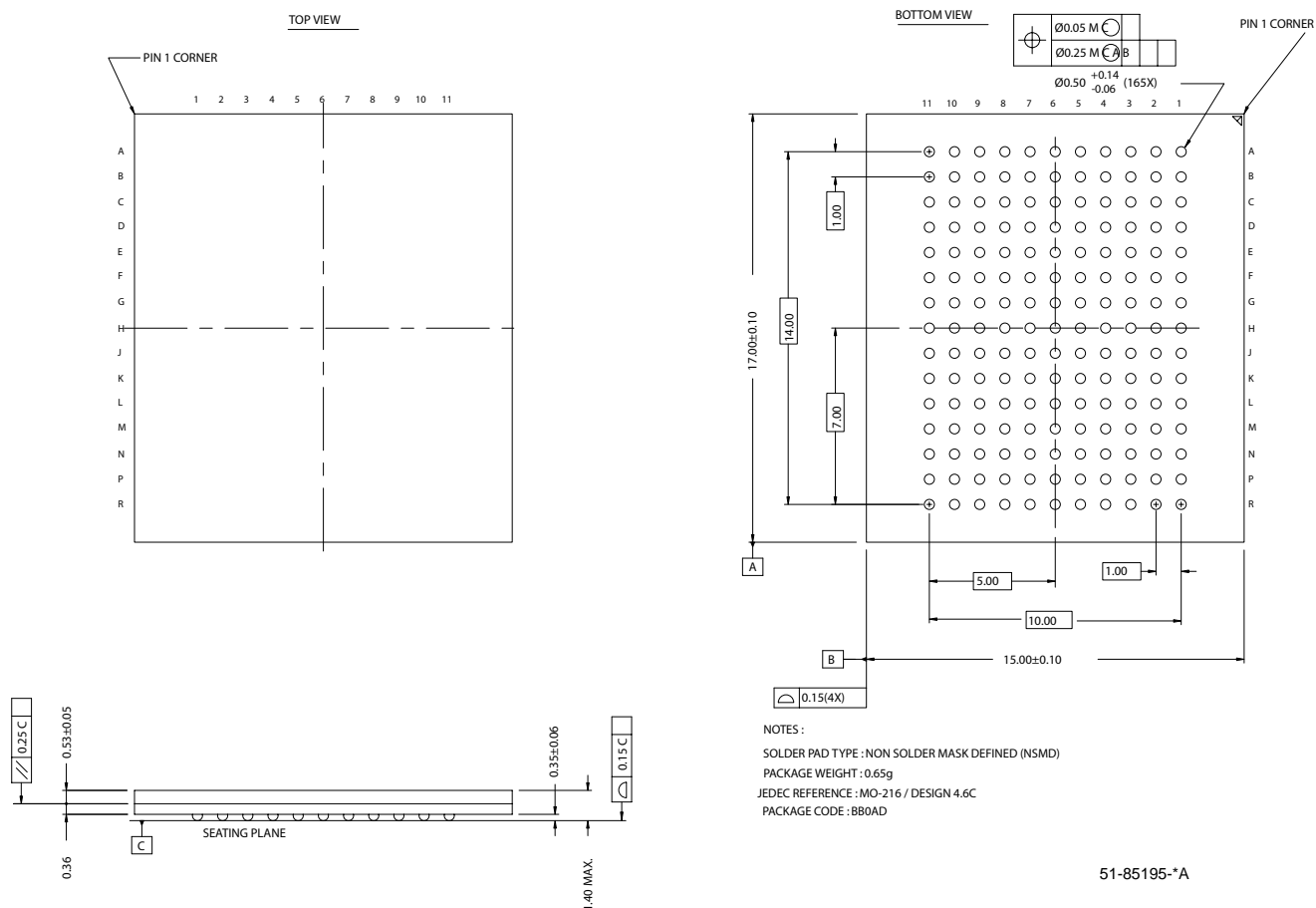

QDR™ SRAMs and Quad Data Rate™ SRAMs comprise a new family of products developed by Cypress, Hitachi, IDT, Micron, NEC and Samsung technology. All product and company names mentioned in this document are the trademarks of their respective holders.

**Document History Page**

| <b>Document Title: CY7C1417AV18/CY7C1428AV18/CY7C1419AV18/CY7C1421AV18 36-Mbit DDR-II SRAM 4-Word Burst Architecture</b><br><b>Document Number: 38-05618</b> |         |            |                 |   |
|--|---------|------------|-----------------|---|
| REV.   | ECN NO. | Issue Date | Orig. of Change | Description of Change   |
| **   | 247331  | See ECN    | SYT             | New Data Sheet  |
| *A   | 253709  | See ECN    | DIM             | Corrected "Switching Waveforms" diagram   |
| *B   | 326519  | See ECN    | SYT             | Removed CY7C1428AV18 from the title<br>Included 300 MHz Speed grade<br>Replaced TBD's with their respective values for $I_{DD}$ and $I_{SB1}$<br>Added Industrial temperature grade<br>Replaced the TBD's on the Thermal Characteristics Table to $\Theta_{JA} = 17.2^{\circ}\text{C/W}$ and $\Theta_{JC} = 3.2^{\circ}\text{C/W}$<br>Replaced TBD's in the Capacitance Table to their respective values for the 165 FBGA Package<br>Changed typo of bit # 47 to bit # 108 under the EXTEST OUTPUT BUS TRI-STATE on Page 18<br>Added lead-free Product Information<br>Updated the Ordering Information by Shading and Unshading MPN's as per availability   |
| *C   | 413975  | See ECN    | NXR             | Added CY7C1428AV18 part number to title<br>Added 278-MHz speed Bin<br>Changed C, C Description in Feature Section and Pin Description<br>Changed address of Cypress Semiconductor Corporation on Page# 1 from "3901 North First Street" to "198 Champion Court"<br>Added Power-up sequence and Wave form on page# 19<br>Added Footnotes# 13, 14, 15 on page# 19<br>Replaced Three-state with Tri-state<br>Changed the description of $I_X$ from Input Load Current to Input Leakage Current on page# 20<br>Modified the $I_{DD}$ and $I_{SB}$ values<br>Modified test condition in Footnote #17 on page# 20 from $V_{DDQ} < V_{DD}$ to $V_{DDQ} \leq V_{DD}$<br>Replaced Package Name column with Package Diagram in the Ordering Information table   |
| *D   | 468029  | See ECN    | NXR             | Converted from Preliminary to Final.<br>Modified the ZQ Definition from Alternately, this pin can be connected directly to $V_{DD}$ to Alternately, this pin can be connected directly to $V_{DDQ}$<br>Included Maximum Ratings for Supply Voltage on $V_{DDQ}$ Relative to GND<br>Changed the Maximum Ratings for DC Input Voltage from $V_{DDQ}$ to $V_{DD}$<br>Changed $t_{TH}$ and $t_{TL}$ from 40 ns to 20 ns, changed $t_{TMSS}$ , $t_{TDIS}$ , $t_{CS}$ , $t_{TMSH}$ , $t_{TDIH}$ , $t_{CH}$ from 10 ns to 5 ns and changed $t_{TDOV}$ from 20 ns to 10 ns in TAP AC Switching Characteristics table<br>Modified Power-Up waveform<br>Added additional notes in the AC parameter section<br>Modified AC Switching Waveform<br>Changed the Maximum rating of Ambient Temperature with Power Applied from $-10^{\circ}\text{C}$ to $+85^{\circ}\text{C}$ to $-55^{\circ}\text{C}$ to $+125^{\circ}\text{C}$<br>Updated the Typo in the AC Switching Characteristics Table<br>Updated the Ordering Information Table |
| *E   | 505682  | See ECN    | VKN             | Corrected typo in the Functional Description section for burst counter logic  |