

**PRELIMINARY****CY7C1440AV33****CY7C1442AV33****CY7C1446AV33**

36-Mbit (1M x 36/2M x 18/512K x 72) Pipelined Sync SRAM

Features

- Supports bus operation up to 250 MHz
- Available speed grades are 250, 200, 167 MHz
- Registered inputs and outputs for pipelined operation
- 3.3V core power supply
- 2.5V/3.3V I/O operation
- Fast clock-to-output times
 - 2.6 ns (for 250-MHz device)
 - 3.2 ns (for 200-MHz device)
 - 3.4 ns (for 167-MHz device)
- Provide high-performance 3-1-1 access rate
- User-selectable burst counter supporting Intel® Pentium® interleaved or linear burst sequences
- Separate processor and controller address strobes
- Synchronous self-timed writes
- Asynchronous output enable
- Single Cycle Chip Deselect
- Offered in JEDEC-standard 100-pin TQFP, 165-Ball fBGA and 209-Ball fBGA packages
- Also available in lead-free packages
- IEEE 1149.1 JTAG-Compatible Boundary Scan
- “ZZ” Sleep Mode Option

Selection Guide

	250 MHz	200 MHz	167 MHz	Unit
Maximum Access Time	2.6	3.2	3.4	ns
Maximum Operating Current	475	425	375	mA
Maximum CMOS Standby Current	100	100	100	mA

Shaded areas contain advance information. Please contact your local Cypress sales representative for availability of these parts.

Notes:

1. For best-practices recommendations, please refer to the Cypress application note *System Design Guidelines* on www.cypress.com.
2. CE₃, CE₂ are for TQFP and 165 fBGA package only.

Functional Description^[1]

The CY7C1440AV33/CY7C1442AV33/CY7C1446AV33 SRAM integrates 1,048,576 x 36, 2,097,152 x 18 and 524,288 x 72 SRAM cells with advanced synchronous peripheral circuitry and a two-bit counter for internal burst operation. All synchronous inputs are gated by registers controlled by a positive-edge-triggered Clock Input (CLK). The synchronous inputs include all addresses, all data inputs, address-pipelining Chip Enable (CE₁), depth-expansion Chip Enables (CE₂ and CE₃^[2]), Burst Control inputs (ADSC, ADSP, and ADV), Write Enables (BW_X and BWE), and Global Write (GW). Asynchronous inputs include the Output Enable (OE) and the ZZ pin.

Addresses and chip enables are registered at rising edge of clock when either Address Strobe Processor (ADSP) or Address Strobe Controller (ADSC) are active. Subsequent burst addresses can be internally generated as controlled by the Advance pin (ADV).

Address, data inputs, and write controls are registered on-chip to initiate a self-timed Write cycle. This part supports Byte Write operations (see Pin Descriptions and Truth Table for further details). Write cycles can be one to two or four bytes wide as controlled by the byte write control inputs. GW when active LOW causes all bytes to be written.

The CY7C1440AV33/CY7C1442AV33/CY7C1446AV33 operates from a +3.3V core power supply while all outputs may operate with either a +2.5 or +3.3V supply. All inputs and outputs are JEDEC-standard JESD8-5-compatible.

Logic Block Diagram – CY7C1440AV33 (1 Mbit x 36)

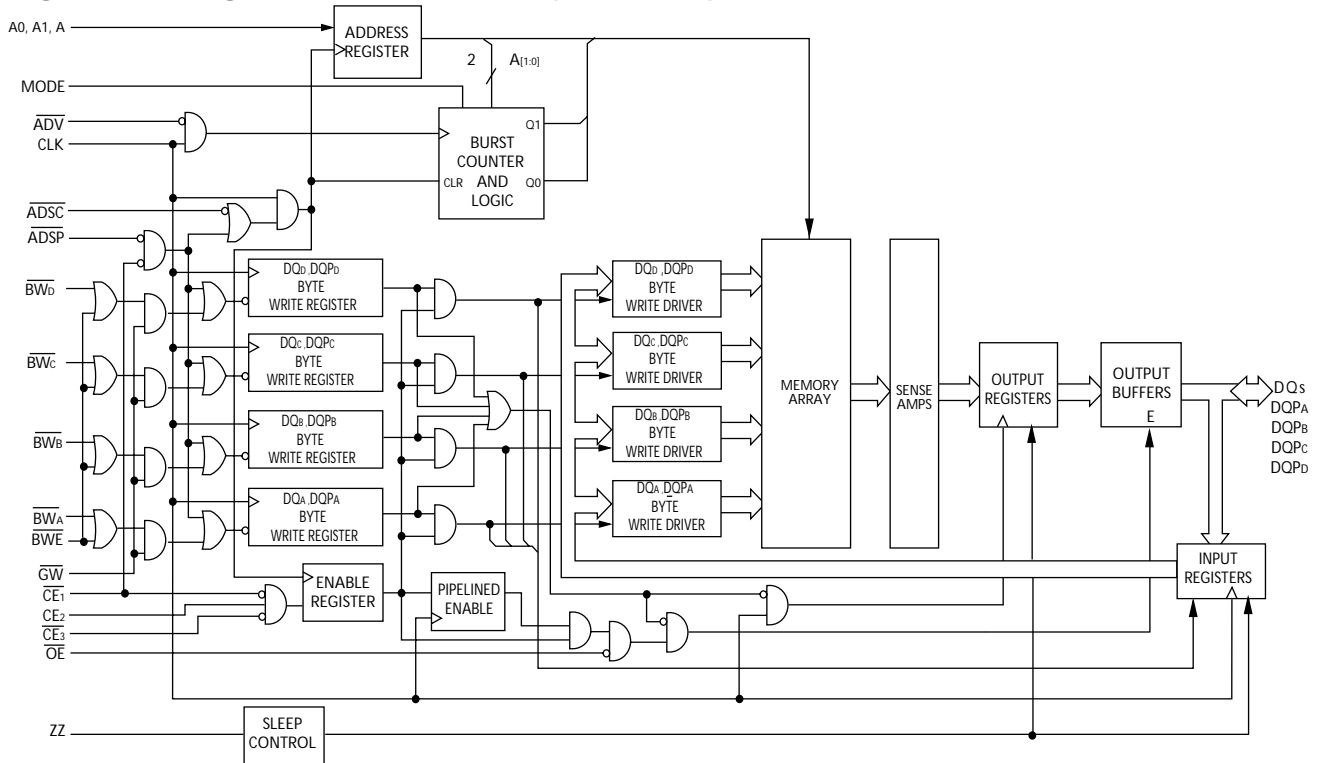

Logic Block Diagram – CY7C1442AV33 (2 Mbit x 18)

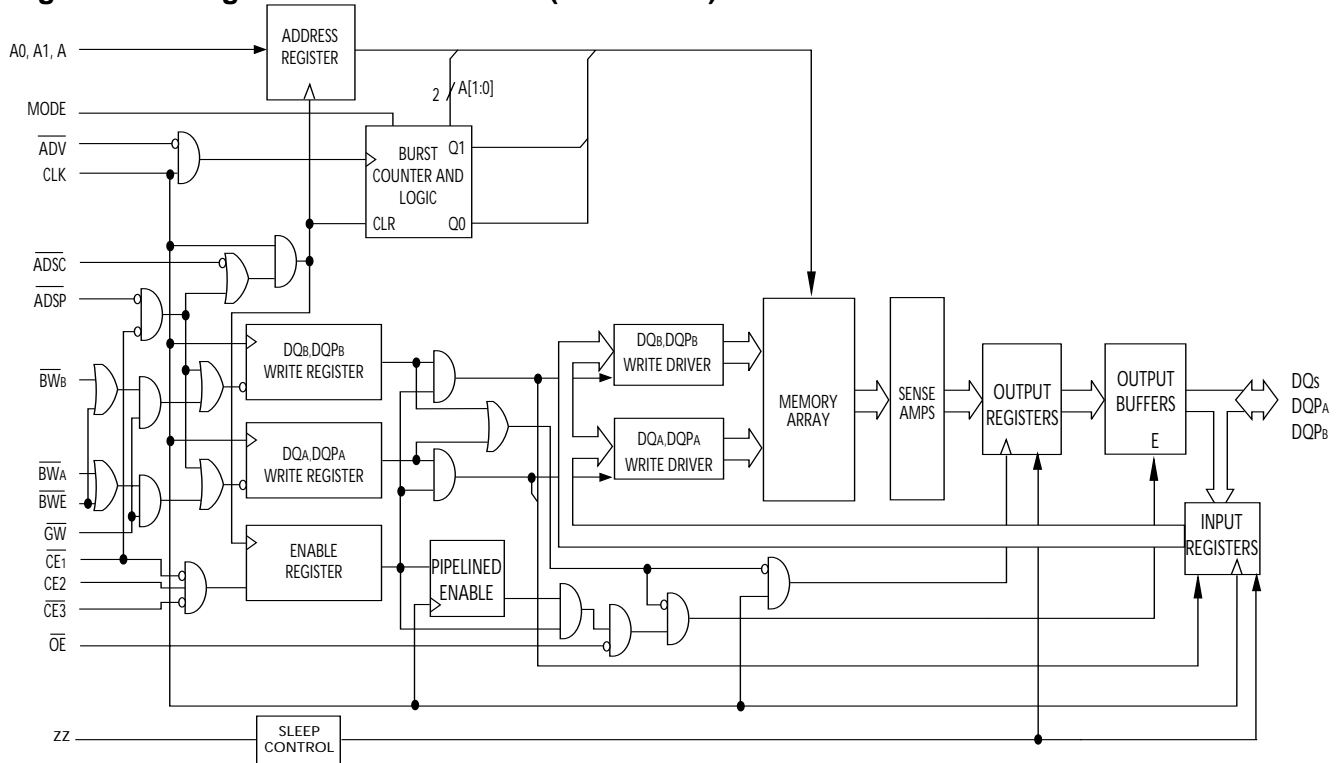

Logic Block Diagram – CY7C1446AV33 (512K x 72)

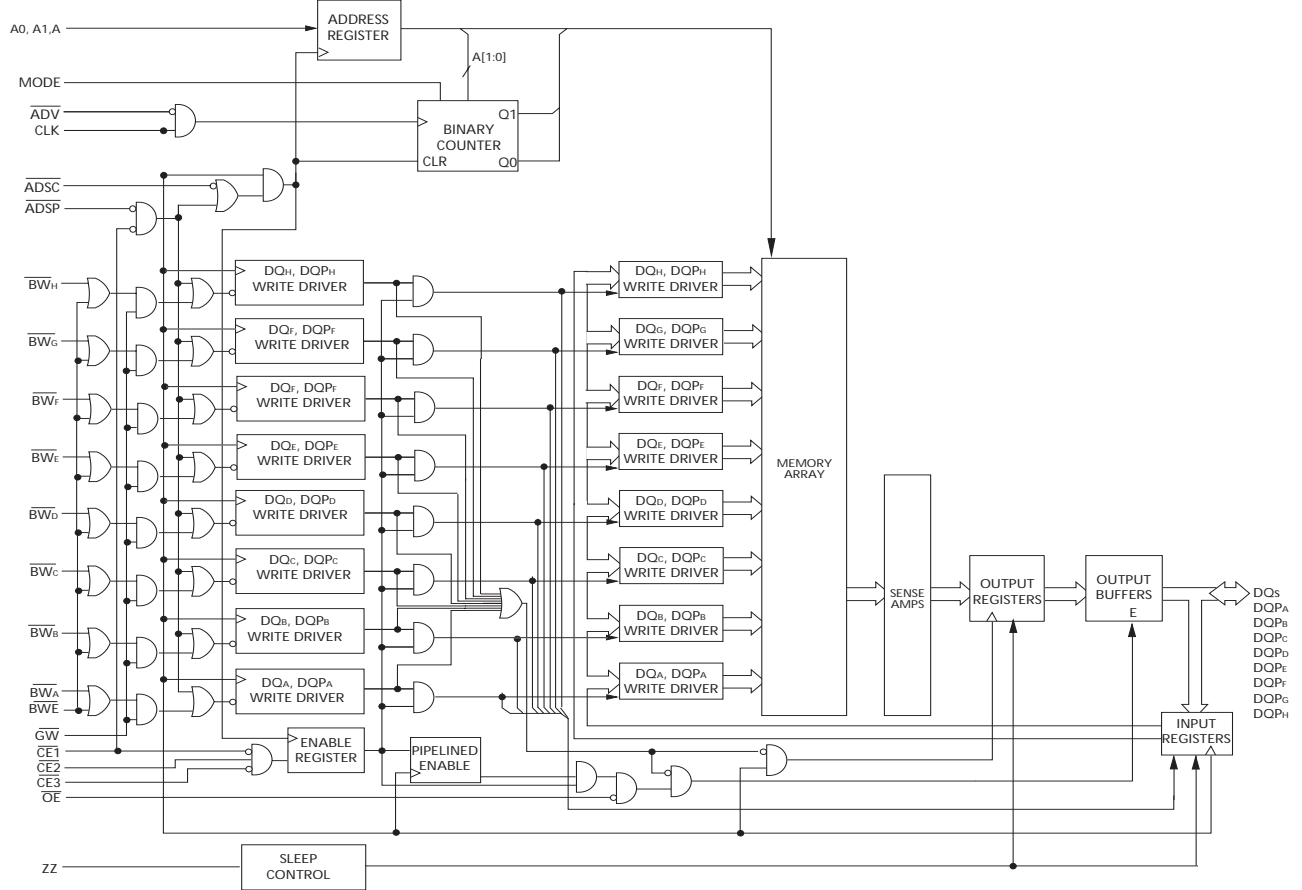

Pin Configurations

100-pin TQFP Pinout

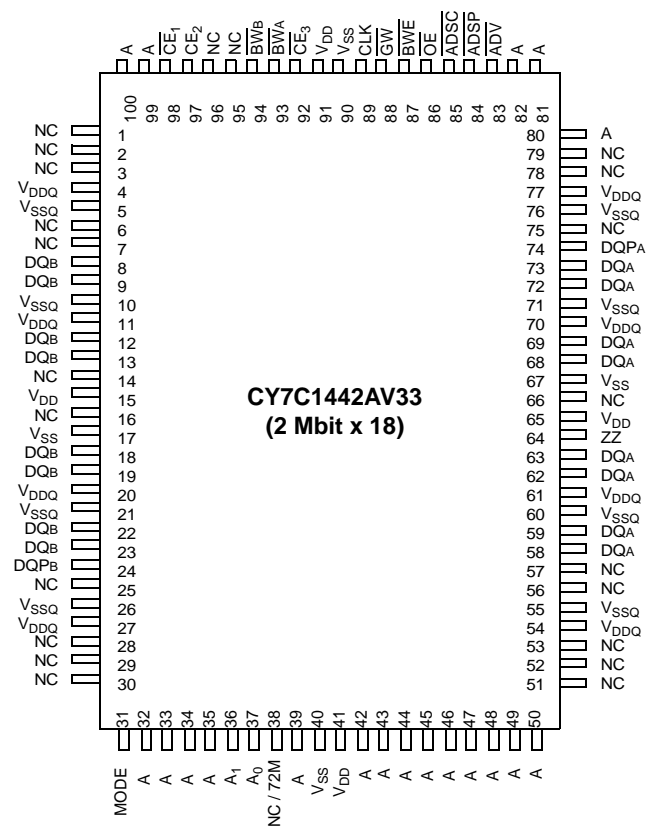
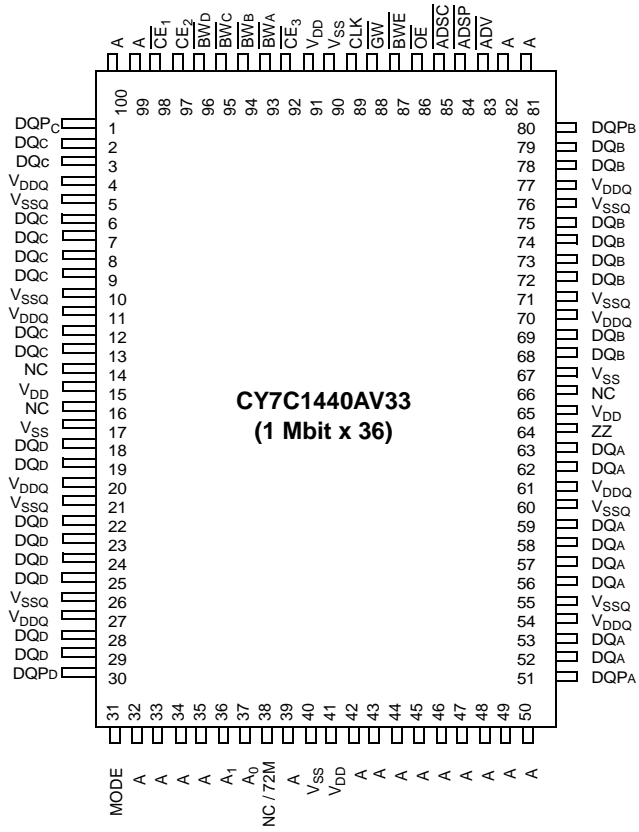



Pin Configurations (continued)

**165-ball fBGA
CY7C1440AV33 (1 Mbit x 36)**

	1	2	3	4	5	6	7	8	9	10	11
A	NC / 288M	A	\overline{CE}_1	\overline{BW}_C	\overline{BW}_B	\overline{CE}_3	\overline{BWE}	\overline{ADSC}	\overline{ADV}	A	NC
B	NC	A	CE2	\overline{BW}_D	\overline{BW}_A	CLK	\overline{GW}	\overline{OE}	\overline{ADSP}	A	NC / 144M
C	DQP _C	NC	V _{DDQ}	V _{SS}	V _{SS}	V _{SS}	V _{SS}	V _{SS}	V _{DDQ}	NC	DQP _B
D	DQ _C	DQ _C	V _{DDQ}	V _{DD}	V _{SS}	V _{SS}	V _{SS}	V _{DD}	V _{DDQ}	DQ _B	DQ _B
E	DQ _C	DQ _C	V _{DDQ}	V _{DD}	V _{SS}	V _{SS}	V _{SS}	V _{DD}	V _{DDQ}	DQ _B	DQ _B
F	DQ _C	DQ _C	V _{DDQ}	V _{DD}	V _{SS}	V _{SS}	V _{SS}	V _{DD}	V _{DDQ}	DQ _B	DQ _B
G	DQ _C	DQ _C	V _{DDQ}	V _{DD}	V _{SS}	V _{SS}	V _{SS}	V _{DD}	V _{DDQ}	DQ _B	DQ _B
H	NC	NC	NC	V _{DD}	V _{SS}	V _{SS}	V _{SS}	V _{DD}	NC	NC	ZZ
J	DQ _D	DQ _D	V _{DDQ}	V _{DD}	V _{SS}	V _{SS}	V _{SS}	V _{DD}	V _{DDQ}	DQ _A	DQ _A
K	DQ _D	DQ _D	V _{DDQ}	V _{DD}	V _{SS}	V _{SS}	V _{SS}	V _{DD}	V _{DDQ}	DQ _A	DQ _A
L	DQ _D	DQ _D	V _{DDQ}	V _{DD}	V _{SS}	V _{SS}	V _{SS}	V _{DD}	V _{DDQ}	DQ _A	DQ _A
M	DQ _D	DQ _D	V _{DDQ}	V _{DD}	V _{SS}	V _{SS}	V _{SS}	V _{DD}	V _{DDQ}	DQ _A	DQ _A
N	DQP _D	NC	V _{DDQ}	V _{SS}	NC	A	NC	V _{SS}	V _{DDQ}	NC	DQP _A
P	NC	NC / 72M	A	A	TDI	A1	TDO	A	A	A	A
R	MODE	A	A	A	TMS	A0	TCK	A	A	A	A

CY7C1442AV33 (2 Mbit x 18)

	1	2	3	4	5	6	7	8	9	10	11
A	NC / 288M	A	\overline{CE}_1	\overline{BW}_B	NC	\overline{CE}_3	\overline{BWE}	\overline{ADSC}	\overline{ADV}	A	A
B	NC	A	CE2	NC	\overline{BW}_A	CLK	\overline{GW}	\overline{OE}	\overline{ADSP}	A	NC / 144M
C	NC	NC	V _{DDQ}	V _{SS}	V _{SS}	V _{SS}	V _{SS}	V _{SS}	V _{DDQ}	NC	DQP _A
D	NC	DQ _B	V _{DDQ}	V _{DD}	V _{SS}	V _{SS}	V _{SS}	V _{DD}	V _{DDQ}	NC	DQ _A
E	NC	DQ _B	V _{DDQ}	V _{DD}	V _{SS}	V _{SS}	V _{SS}	V _{DD}	V _{DDQ}	NC	DQ _A
F	NC	DQ _B	V _{DDQ}	V _{DD}	V _{SS}	V _{SS}	V _{SS}	V _{DD}	V _{DDQ}	NC	DQ _A
G	NC	DQ _B	V _{DDQ}	V _{DD}	V _{SS}	V _{SS}	V _{SS}	V _{DD}	V _{DDQ}	NC	DQ _A
H	NC	NC	NC	V _{DD}	V _{SS}	V _{SS}	V _{SS}	V _{DD}	NC	NC	ZZ
J	DQ _B	NC	V _{DDQ}	V _{DD}	V _{SS}	V _{SS}	V _{SS}	V _{DD}	V _{DDQ}	DQ _A	NC
K	DQ _B	NC	V _{DDQ}	V _{DD}	V _{SS}	V _{SS}	V _{SS}	V _{DD}	V _{DDQ}	DQ _A	NC
L	DQ _B	NC	V _{DDQ}	V _{DD}	V _{SS}	V _{SS}	V _{SS}	V _{DD}	V _{DDQ}	DQ _A	NC
M	DQ _B	NC	V _{DDQ}	V _{DD}	V _{SS}	V _{SS}	V _{SS}	V _{DD}	V _{DDQ}	DQ _A	NC
N	DQP _B	NC	V _{DDQ}	V _{SS}	NC	A	NC	V _{SS}	V _{DDQ}	NC	NC
P	NC	NC / 72M	A	A	TDI	A1	TDO	A	A	A	A
R	MODE	A	A	A	TMS	A0	TCK	A	A	A	A

Pin Configurations (continued)

**209-ball fBGA
CY7C1446AV33 (512K x 72)**

	1	2	3	4	5	6	7	8	9	10	11
A	DQ _G	DQ _G	A	CE ₂	$\overline{\text{ADSP}}$	$\overline{\text{ADSC}}$	$\overline{\text{ADV}}$	$\overline{\text{CE}}_3$	A	DQ _B	DQ _B
B	DQ _G	DQ _G	$\overline{\text{BWS}}_C$	$\overline{\text{BWS}}_G$	NC	$\overline{\text{BW}}$	A	$\overline{\text{BWS}}_B$	$\overline{\text{BWS}}_F$	DQ _B	DQ _B
C	DQ _G	DQ _G	$\overline{\text{BWS}}_H$	$\overline{\text{BWS}}_D$	NC	$\overline{\text{CE}}_1$	NC	$\overline{\text{BWS}}_E$	$\overline{\text{BWS}}_A$	DQ _B	DQ _B
D	DQ _G	DQ _G	V _{SS}	NC	NC	$\overline{\text{OE}}$	$\overline{\text{GW}}$	NC	V _{SS}	DQ _B	DQ _B
E	DQP _G	DQP _C	V _{DDQ}	V _{DDQ}	V _{DD}	V _{DD}	V _{DD}	V _{DDQ}	V _{DDQ}	DQP _F	DQP _B
F	DQ _C	DQ _C	V _{SS}	V _{SS}	V _{SS}	NC	V _{SS}	V _{SS}	V _{SS}	DQ _F	DQ _F
G	DQ _C	DQ _C	V _{DDQ}	V _{DDQ}	V _{DD}	NC	V _{DD}	V _{DDQ}	V _{DDQ}	DQ _F	DQ _F
H	DQ _C	DQ _C	V _{SS}	V _{SS}	V _{SS}	NC	V _{SS}	V _{SS}	V _{SS}	DQ _F	DQ _F
J	DQ _C	DQ _C	V _{DDQ}	V _{DDQ}	V _{DD}	NC	V _{DD}	V _{DDQ}	V _{DDQ}	DQ _F	DQ _F
K	NC	NC	CLK	NC	V _{SS}	V _{SS}	V _{SS}	NC	NC	NC	NC
L	DQ _H	DQ _H	V _{DDQ}	V _{DDQ}	V _{DD}	NC	V _{DD}	V _{DDQ}	V _{DDQ}	DQ _A	DQ _A
M	DQ _H	DQ _H	V _{SS}	V _{SS}	V _{SS}	NC	V _{SS}	V _{SS}	V _{SS}	DQ _A	DQ _A
N	DQ _H	DQ _H	V _{DDQ}	V _{DDQ}	V _{DD}	NC	V _{DD}	V _{DDQ}	V _{DDQ}	DQ _A	DQ _A
P	DQ _H	DQ _H	V _{SS}	V _{SS}	V _{SS}	ZZ	V _{SS}	V _{SS}	V _{SS}	DQ _A	DQ _A
R	DQP _D	DQP _H	V _{DDQ}	V _{DDQ}	V _{DD}	V _{DD}	V _{DD}	V _{DDQ}	V _{DDQ}	DQP _A	DQP _E
T	DQ _D	DQ _D	V _{SS}	NC	NC	MODE	NC	NC	V _{SS}	DQ _E	DQ _E
U	DQ _D	DQ _D	NC	A	A	A	A	A	A	DQ _E	DQ _E
V	DQ _D	DQ _D	A	A	A	A1	A	A	A	DQ _E	DQ _E
W	DQ _D	DQ _D	TMS	TDI	A	A0	A	TDO	TCK	DQ _E	DQ _E

Pin Definitions

Name	I/O	Description
A ₀ , A ₁ , A	Input-Synchronous	Address Inputs used to select one of the address locations. Sampled at the rising edge of the CLK if ADSP or ADSC is active LOW, and CE ₁ , CE ₂ , and CE ₃ ^[2] are sampled active. A1: A0 are fed to the two-bit counter.
$\overline{\text{BW}}_A$, $\overline{\text{BW}}_B$, $\overline{\text{BW}}_C$, $\overline{\text{BW}}_D$, $\overline{\text{BW}}_E$, $\overline{\text{BW}}_F$, $\overline{\text{BW}}_G$, $\overline{\text{BW}}_H$	Input-Synchronous	Byte Write Select Inputs, active LOW. Qualified with $\overline{\text{BWE}}$ to conduct byte writes to the SRAM. Sampled on the rising edge of CLK.
$\overline{\text{GW}}$	Input-Synchronous	Global Write Enable Input, active LOW. When asserted LOW on the rising edge of CLK, a global write is conducted (ALL bytes are written, regardless of the values on BW _x and BWE).
$\overline{\text{BWE}}$	Input-Synchronous	Byte Write Enable Input, active LOW. Sampled on the rising edge of CLK. This signal must be asserted LOW to conduct a byte write.
CLK	Input-Clock	Clock Input. Used to capture all synchronous inputs to the device. Also used to increment the burst counter when ADV is asserted LOW, during a burst operation.
$\overline{\text{CE}}_1$	Input-Synchronous	Chip Enable 1 Input, active LOW. Sampled on the rising edge of CLK. Used in conjunction with CE ₂ and CE ₃ to select/deselect the device. ADSP is ignored if CE ₁ is HIGH. CE ₁ is sampled only when a new external address is loaded.

Pin Definitions (continued)

Name	I/O	Description
CE ₂ ^[2]	Input-Synchronous	Chip Enable 2 Input, active HIGH. Sampled on the rising edge of CLK. Used in conjunction with CE ₁ and CE ₃ to select/deselect the device. CE ₂ is sampled only when a new external address is loaded.
CE ₃ ^[2]	Input-Synchronous	Chip Enable 3 Input, active LOW. Sampled on the rising edge of CLK. Used in conjunction with CE ₁ and CE ₂ to select/deselect the device. Not available for AJ package version. Not connected for BGA. Where referenced, CE ₃ is assumed active throughout this document for BGA. CE ₃ is sampled only when a new external address is loaded.
OE	Input-Asynchronous	Output Enable, asynchronous input, active LOW. Controls the direction of the I/O pins. When LOW, the I/O pins behave as outputs. When deasserted HIGH, I/O pins are tri-stated, and act as input data pins. OE is masked during the first clock of a read cycle when emerging from a deselected state.
ADV	Input-Synchronous	Advance Input signal, sampled on the rising edge of CLK, active LOW. When asserted, it automatically increments the address in a burst cycle.
ADSP	Input-Synchronous	Address Strobe from Processor, sampled on the rising edge of CLK, active LOW. When asserted LOW, addresses presented to the device are captured in the address registers. A1: A0 are also loaded into the burst counter. When ADSP and ADSC are both asserted, only ADSP is recognized. ADSP is ignored when CE ₁ is deasserted HIGH.
ADSC	Input-Synchronous	Address Strobe from Controller, sampled on the rising edge of CLK, active LOW. When asserted LOW, addresses presented to the device are captured in the address registers. A1: A0 are also loaded into the burst counter. When ADSP and ADSC are both asserted, only ADSP is recognized.
ZZ	Input-Asynchronous	ZZ "sleep" Input, active HIGH. When asserted HIGH places the device in a non-time-critical "sleep" condition with data integrity preserved. For normal operation, this pin has to be LOW or left floating. ZZ pin has an internal pull-down.
DQs, DQP _x	I/O-Synchronous	Bidirectional Data I/O lines. As inputs, they feed into an on-chip data register that is triggered by the rising edge of CLK. As outputs, they deliver the data contained in the memory location specified by the addresses presented during the previous clock rise of the read cycle. The direction of the pins is controlled by OE. When OE is asserted LOW, the pins behave as outputs. When HIGH, DQs and DQP _x are placed in a tri-state condition.
V _{DD}	Power Supply	Power supply inputs to the core of the device.
V _{SS}	Ground	Ground for the core of the device.
V _{SSQ}	I/O Ground	Ground for the I/O circuitry.
V _{DDQ}	I/O Power Supply	Power supply for the I/O circuitry.
MODE	Input-Static	Selects Burst Order. When tied to GND selects linear burst sequence. When tied to V _{DD} or left floating selects interleaved burst sequence. This is a strap pin and should remain static during device operation. Mode Pin has an internal pull-up.
TDO	JTAG serial output Synchronous	Serial data-out to the JTAG circuit. Delivers data on the negative edge of TCK. If the JTAG feature is not being utilized, this pin should be disconnected. This pin is not available on TQFP packages.
TDI	JTAG serial input Synchronous	Serial data-In to the JTAG circuit. Sampled on the rising edge of TCK. If the JTAG feature is not being utilized, this pin can be disconnected or connected to V _{DD} . This pin is not available on TQFP packages.
TMS	JTAG serial input Synchronous	Serial data-In to the JTAG circuit. Sampled on the rising edge of TCK. If the JTAG feature is not being utilized, this pin can be disconnected or connected to V _{DD} . This pin is not available on TQFP packages.
TCK	JTAG-Clock	Clock input to the JTAG circuitry. If the JTAG feature is not being utilized, this pin must be connected to V _{SS} . This pin is not available on TQFP packages.
NC	–	No Connects. Not internally connected to the die
NC/72M, NC/144M, NC/288M	–	No Connects. Not internally connected to the die. NC/72M, NC/144M and NC/288M are address expansion pins are not internally connected to the die.

Functional Overview

All synchronous inputs pass through input registers controlled by the rising edge of the clock. All data outputs pass through output registers controlled by the rising edge of the clock. Maximum access delay from the clock rise (t_{CO}) is 2.6ns (250-MHz device).

The CY7C1440AV33/CY7C1442AV33/CY7C1446AV33 supports secondary cache in systems utilizing either a linear or interleaved burst sequence. The interleaved burst order supports Pentium and i486™ processors. The linear burst sequence is suited for processors that utilize a linear burst sequence. The burst order is user selectable, and is determined by sampling the MODE input. Accesses can be initiated with either the Processor Address Strobe (ADSP) or the Controller Address Strobe (ADSC). Address advancement through the burst sequence is controlled by the ADV input. A two-bit on-chip wraparound burst counter captures the first address in a burst sequence and automatically increments the address for the rest of the burst access.

Byte Write operations are qualified with the Byte Write Enable (BWE) and Byte Write Select (BW_X) inputs. A Global Write Enable (GW) overrides all Byte Write inputs and writes data to all four bytes. All writes are simplified with on-chip synchronous self-timed Write circuitry.

Three synchronous Chip Selects (\overline{CE}_1 , \overline{CE}_2 , \overline{CE}_3) and an asynchronous Output Enable (OE) provide for easy bank selection and output tri-state control. ADSP is ignored if \overline{CE}_1 is HIGH.

Single Read Accesses

This access is initiated when the following conditions are satisfied at clock rise: (1) ADSP or ADSC is asserted LOW, (2) \overline{CE}_1 , \overline{CE}_2 , \overline{CE}_3 are all asserted active, and (3) the Write signals (GW, BWE) are all desasserted HIGH. ADSP is ignored if \overline{CE}_1 is HIGH. The address presented to the address inputs (A) is stored into the address advancement logic and the Address Register while being presented to the memory array. The corresponding data is allowed to propagate to the input of the Output Registers. At the rising edge of the next clock the data is allowed to propagate through the output register and onto the data bus within 2.6 ns (250-MHz device) if OE is active LOW. The only exception occurs when the SRAM is emerging from a deselected state to a selected state, its outputs are always tri-stated during the first cycle of the access. After the first cycle of the access, the outputs are controlled by the OE signal. Consecutive single Read cycles are supported. Once the SRAM is deselected at clock rise by the chip select and either ADSP or ADSC signals, its output will tri-state immediately.

Single Write Accesses Initiated by ADSP

This access is initiated when both of the following conditions are satisfied at clock rise: (1) ADSP is asserted LOW, and (2) \overline{CE}_1 , \overline{CE}_2 , \overline{CE}_3 are all asserted active. The address presented to A is loaded into the address register and the address advancement logic while being delivered to the memory array. The Write signals (GW, BWE, and BW_X) and ADV inputs are ignored during this first cycle.

ADSP-triggered Write accesses require two clock cycles to complete. If GW is asserted LOW on the second clock rise, the data presented to the DQs inputs is written into the corresponding address location in the memory array. If GW is HIGH,

then the Write operation is controlled by \overline{BWE} and \overline{BW}_X signals.

The CY7C1440AV33/CY7C1442AV33/CY7C1446AV33 provides Byte Write capability that is described in the Write Cycle Descriptions table. Asserting the Byte Write Enable input (\overline{BWE}) with the selected Byte Write (\overline{BW}_X) input, will selectively write to only the desired bytes. Bytes not selected during a Byte Write operation will remain unaltered. A synchronous self-timed Write mechanism has been provided to simplify the Write operations.

Because CY7C1440AV33/CY7C1442AV33/CY7C1446AV33 is a common I/O device, the Output Enable (OE) must be deasserted HIGH before presenting data to the DQs inputs. Doing so will tri-state the output drivers. As a safety precaution, DQs are automatically tri-stated whenever a Write cycle is detected, regardless of the state of OE.

Single Write Accesses Initiated by ADSC

ADSC Write accesses are initiated when the following conditions are satisfied: (1) ADSC is asserted LOW, (2) ADSP is desasserted HIGH, (3) \overline{CE}_1 , \overline{CE}_2 , \overline{CE}_3 are all asserted active, and (4) the appropriate combination of the Write inputs (GW, BWE, and \overline{BW}_X) are asserted active to conduct a Write to the desired byte(s). ADSC-triggered Write accesses require a single clock cycle to complete. The address presented to A is loaded into the address register and the address advancement logic while being delivered to the memory array. The ADV input is ignored during this cycle. If a global Write is conducted, the data presented to the DQs is written into the corresponding address location in the memory core. If a Byte Write is conducted, only the selected bytes are written. Bytes not selected during a Byte Write operation will remain unaltered. A synchronous self-timed Write mechanism has been provided to simplify the Write operations.

Because CY7C1440AV33/CY7C1442AV33/CY7C1446AV33 is a common I/O device, the Output Enable (OE) must be deasserted HIGH before presenting data to the DQs inputs. Doing so will tri-state the output drivers. As a safety precaution, DQs are automatically tri-stated whenever a Write cycle is detected, regardless of the state of OE.

Burst Sequences

The CY7C1440AV33/CY7C1442AV33/CY7C1446AV33 provides a two-bit wraparound counter, fed by A1: A0, that implements either an interleaved or linear burst sequence. The interleaved burst sequence is designed specifically to support Intel Pentium applications. The linear burst sequence is designed to support processors that follow a linear burst sequence. The burst sequence is user selectable through the MODE input.

Asserting \overline{ADV} LOW at clock rise will automatically increment the burst counter to the next address in the burst sequence. Both Read and Write burst operations are supported.

Sleep Mode

The ZZ input pin is an asynchronous input. Asserting ZZ places the SRAM in a power conservation "sleep" mode. Two clock cycles are required to enter into or exit from this "sleep" mode. While in this mode, data integrity is guaranteed. Accesses pending when entering the "sleep" mode are not considered valid nor is the completion of the operation guaranteed. The device must be deselected prior to entering



the “sleep” mode. \overline{CE}_1 , \overline{CE}_2 , \overline{CE}_3 , \overline{ADSP} , and \overline{ADSC} must remain inactive for the duration of t_{ZZREC} after the ZZ input returns LOW.

**Interleaved Burst Address Table
(MODE = Floating or V_{DD})**

First Address A1: A0	Second Address A1: A0	Third Address A1: A0	Fourth Address A1: A0
00	01	10	11
01	00	11	10
10	11	00	01
11	10	01	00

Linear Burst Address Table (MODE = GND)

First Address A1: A0	Second Address A1: A0	Third Address A1: A0	Fourth Address A1: A0
00	01	10	11
01	10	11	00
10	11	00	01
11	00	01	10

ZZ Mode Electrical Characteristics

Parameter	Description	Test Conditions	Min.	Max.	Unit
I_{DDZZ}	Sleep mode standby current	$ZZ \geq V_{DD} - 0.2V$		100	mA
t_{ZZS}	Device operation to ZZ	$ZZ \geq V_{DD} - 0.2V$		$2t_{CYC}$	ns
t_{ZZREC}	ZZ recovery time	$ZZ \leq 0.2V$	$2t_{CYC}$		ns
t_{ZZI}	ZZ Active to sleep current	This parameter is sampled		$2t_{CYC}$	ns
t_{RZZI}	ZZ Inactive to exit sleep current	This parameter is sampled	0		ns

Truth Table [3, 4, 5, 6, 7, 8]

Operation	Add. Used	\overline{CE}_1	\overline{CE}_2	\overline{CE}_3	ZZ	ADSP	ADSC	ADV	WRITE	OE	CLK	DQ
Deselect Cycle, Power Down	None	H	X	X	L	X	L	X	X	X	L-H	Tri-State
Deselect Cycle, Power Down	None	L	L	X	L	L	X	X	X	X	L-H	Tri-State
Deselect Cycle, Power Down	None	L	X	H	L	L	X	X	X	X	L-H	Tri-State
Deselect Cycle, Power Down	None	L	L	X	L	H	L	X	X	X	L-H	Tri-State
Deselect Cycle, Power Down	None	L	X	H	L	H	L	X	X	X	L-H	Tri-State
Sleep Mode, Power Down	None	X	X	X	H	X	X	X	X	X	X	Tri-State
READ Cycle, Begin Burst	External	L	H	L	L	L	X	X	X	L	L-H	Q
READ Cycle, Begin Burst	External	L	H	L	L	L	X	X	X	H	L-H	Tri-State
WRITE Cycle, Begin Burst	External	L	H	L	L	H	L	X	L	X	L-H	D
READ Cycle, Begin Burst	External	L	H	L	L	H	L	X	H	L	L-H	Q
READ Cycle, Begin Burst	External	L	H	L	L	H	L	X	H	H	L-H	Tri-State

Notes:

- X = “Don’t Care.” H = Logic HIGH, L = Logic LOW.
- WRITE = L when any one or more Byte Write enable signals and $\overline{BWE} = L$ or $\overline{GW} = L$. WRITE = H when all Byte write enable signals, \overline{BWE} , $\overline{GW} = H$.
- The DQ pins are controlled by the current cycle and the OE signal. OE is asynchronous and is not sampled with the clock.
- \overline{CE}_1 , \overline{CE}_2 , and \overline{CE}_3 are available only in the TQFP package. BGA package has only 2 chip selects \overline{CE}_1 and \overline{CE}_2 .
- The SRAM always initiates a read cycle when ADSP is asserted, regardless of the state of \overline{GW} , \overline{BWE} , or \overline{BW}_x . Writes may occur only on subsequent clocks after the ADSP or with the assertion of ADSC. As a result, OE must be driven HIGH prior to the start of the write cycle to allow the outputs to tri-state. OE is a don’t care for the remainder of the write cycle
- OE is asynchronous and is not sampled with the clock rise. It is masked internally during write cycles. During a read cycle all data bits are Tri-State when OE is inactive or when the device is deselected, and all data bits behave as output when OE is active (LOW).



Truth Table (continued)^[3, 4, 5, 6, 7, 8]

Operation	Add. Used	CE ₁	CE ₂	CE ₃	ZZ	ADSP	ADSC	ADV	WRITE	OE	CLK	DQ
READ Cycle, Continue Burst	Next	X	X	X	L	H	H	L	H	L	L-H	Q
READ Cycle, Continue Burst	Next	X	X	X	L	H	H	L	H	H	L-H	Tri-State
READ Cycle, Continue Burst	Next	H	X	X	L	X	H	L	H	L	L-H	Q
READ Cycle, Continue Burst	Next	H	X	X	L	X	H	L	H	H	L-H	Tri-State
WRITE Cycle, Continue Burst	Next	X	X	X	L	H	H	L	L	X	L-H	D
WRITE Cycle, Continue Burst	Next	H	X	X	L	X	H	L	L	X	L-H	D
READ Cycle, Suspend Burst	Current	X	X	X	L	H	H	H	H	L	L-H	Q
READ Cycle, Suspend Burst	Current	X	X	X	L	H	H	H	H	H	L-H	Tri-State
READ Cycle, Suspend Burst	Current	H	X	X	L	X	H	H	H	L	L-H	Q
READ Cycle, Suspend Burst	Current	H	X	X	L	X	H	H	H	H	L-H	Tri-State
WRITE Cycle, Suspend Burst	Current	X	X	X	L	H	H	H	L	X	L-H	D
WRITE Cycle, Suspend Burst	Current	H	X	X	L	X	H	H	L	X	L-H	D

Truth Table for Read/Write^[5,9,10]

Function (CY7C1440AV33)	GW	BWE	BW _D	BW _C	BW _B	BW _A
Read	H	H	X	X	X	X
Read	H	L	H	H	H	H
Write Byte A – (DQ _A and DQP _A)	H	L	H	H	H	L
Write Byte B – (DQ _B and DQP _B)	H	L	H	H	L	H
Write Bytes B, A	H	L	H	H	L	L
Write Byte C – (DQ _C and DQP _C)	H	L	H	L	H	H
Write Bytes C, A	H	L	H	L	H	L
Write Bytes C, B	H	L	H	L	L	H
Write Bytes C, B, A	H	L	H	L	L	L
Write Byte D – (DQ _D and DQP _D)	H	L	L	H	H	H
Write Bytes D, A	H	L	L	H	H	L
Write Bytes D, B	H	L	L	H	L	H
Write Bytes D, B, A	H	L	L	H	L	L
Write Bytes D, C	H	L	L	L	H	H
Write Bytes D, C, A	H	L	L	L	H	L
Write Bytes D, C, B	H	L	L	L	L	H
Write All Bytes	H	L	L	L	L	L
Write All Bytes	L	X	X	X	X	X

Truth Table for Read/Write^[5, 9, 10]

Function (CY7C1442AV33)	GW	BWE	BW _B	BW _A
Read	H	H	X	X
Read	H	L	H	H
Write Byte A – (DQ _A and DQP _A)	H	L	H	L
Write Byte B – (DQ _B and DQP _B)	H	L	L	H
Write Bytes B, A	H	L	L	L
Write All Bytes	H	L	L	L
Write All Bytes	L	X	X	X

Notes:

9. BW_x represents any byte write signal. To enable any byte write BW_x, a Logic LOW signal should be applied at clock rise. Any number of byte writes can be enabled at the same time for any given write.
10. Table only lists a partial listing of the byte write combinations. Any combination of BW_x is valid. Appropriate write will be done based on which byte write is active.

Truth Table for Read/Write^[5, 9, 10]

Function (CY7C1446AV33)	\overline{GW}	\overline{BWE}	$\overline{BW_x}$
Read	H	H	X
Read	H	L	All $\overline{BW} = H$
Write Byte x – (DQ _x and DQP _x)	H	L	L
Write All Bytes	H	L	All $\overline{BW} = L$
Write All Bytes	L	X	X

IEEE 1149.1 Serial Boundary Scan (JTAG)

The CY7C1440AV33/CY7C1442AV33/CY7C1446AV33 incorporates a serial boundary scan test access port (TAP). This part is fully compliant with IEEE Standard 1149.1. The TAP operates using JEDEC-standard 3.3V or 2.5V I/O logic levels.

The CY7C1440AV33/CY7C1442AV33/CY7C1446AV33 contains a TAP controller, instruction register, boundary scan register, bypass register, and ID register.

Disabling the JTAG Feature

It is possible to operate the SRAM without using the JTAG feature. To disable the TAP controller, TCK must be tied LOW (V_{SS}) to prevent clocking of the device. TDI and TMS are internally pulled up and may be unconnected. They may alternately be connected to V_{DD} through a pull-up resistor. TDO should be left unconnected. Upon power-up, the device will come up in a reset state which will not interfere with the operation of the device.

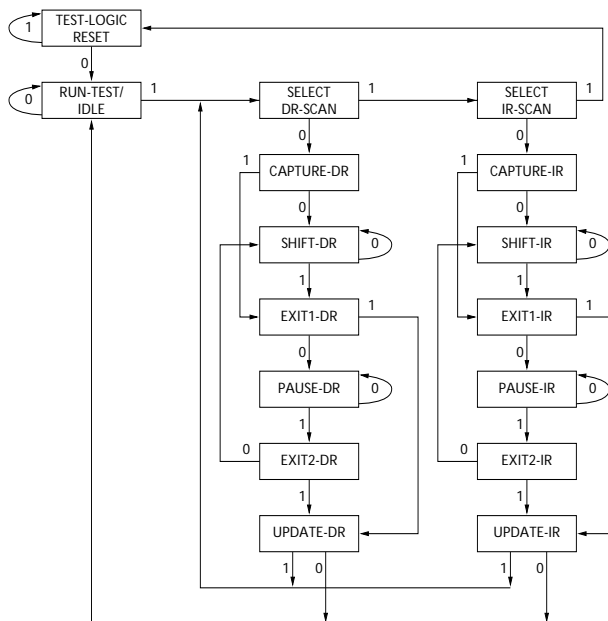
TAP Controller State Diagram

The 0/1 next to each state represents the value of TMS at the rising edge of TCK.

Test Access Port (TAP)
Test Clock (TCK)

The test clock is used only with the TAP controller. All inputs are captured on the rising edge of TCK. All outputs are driven from the falling edge of TCK.

Test MODE SELECT (TMS)

The TMS input is used to give commands to the TAP controller and is sampled on the rising edge of TCK. It is allowable to leave this ball unconnected if the TAP is not used. The ball is pulled up internally, resulting in a logic HIGH level.

Test Data-In (TDI)

The TDI ball is used to serially input information into the registers and can be connected to the input of any of the registers. The register between TDI and TDO is chosen by the instruction that is loaded into the TAP instruction register. TDI is internally pulled up and can be unconnected if the TAP is unused in an application. TDI is connected to the most significant bit (MSB) of any register. (See Tap Controller Block Diagram.)

Test Data-Out (TDO)

The TDO output ball is used to serially clock data-out from the registers. The output is active depending upon the current state of the TAP state machine. The output changes on the falling edge of TCK. TDO is connected to the least significant bit (LSB) of any register. (See Tap Controller State Diagram.)

TAP Controller Block Diagram

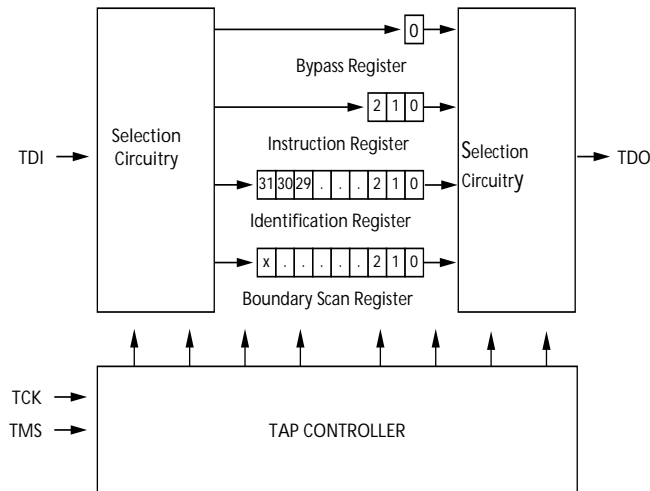

Performing a TAP Reset

A RESET is performed by forcing TMS HIGH (V_{DD}) for five rising edges of TCK. This RESET does not affect the operation of the SRAM and may be performed while the SRAM is operating.

At power-up, the TAP is reset internally to ensure that TDO comes up in a High-Z state.

TAP Registers

Registers are connected between the TDI and TDO balls and allow data to be scanned into and out of the SRAM test circuitry. Only one register can be selected at a time through the instruction register. Data is serially loaded into the TDI ball on the rising edge of TCK. Data is output on the TDO ball on the falling edge of TCK.

Instruction Register

Three-bit instructions can be serially loaded into the instruction register. This register is loaded when it is placed between the TDI and TDO balls as shown in the Tap Controller Block Diagram. Upon power-up, the instruction register is loaded with the IDCODE instruction. It is also loaded with the IDCODE instruction if the controller is placed in a reset state as described in the previous section.

When the TAP controller is in the Capture-IR state, the two least significant bits are loaded with a binary "01" pattern to allow for fault isolation of the board-level serial test data path.

Bypass Register

To save time when serially shifting data through registers, it is sometimes advantageous to skip certain chips. The bypass register is a single-bit register that can be placed between the TDI and TDO balls. This allows data to be shifted through the SRAM with minimal delay. The bypass register is set LOW (V_{SS}) when the BYPASS instruction is executed.

Boundary Scan Register

The boundary scan register is connected to all the input and bidirectional balls on the SRAM.

The boundary scan register is loaded with the contents of the RAM I/O ring when the TAP controller is in the Capture-DR

state and is then placed between the TDI and TDO balls when the controller is moved to the Shift-DR state. The EXTTEST, SAMPLE/PRELOAD and SAMPLE Z instructions can be used to capture the contents of the I/O ring.

The Boundary Scan Order tables show the order in which the bits are connected. Each bit corresponds to one of the bumps on the SRAM package. The MSB of the register is connected to TDI, and the LSB is connected to TDO.

Identification (ID) Register

The ID register is loaded with a vendor-specific, 32-bit code during the Capture-DR state when the IDCODE command is loaded in the instruction register. The IDCODE is hardwired into the SRAM and can be shifted out when the TAP controller is in the Shift-DR state. The ID register has a vendor code and other information described in the Identification Register Definitions table.

TAP Instruction Set

Overview

Eight different instructions are possible with the three bit instruction register. All combinations are listed in the Instruction Codes table. Three of these instructions are listed as RESERVED and should not be used. The other five instructions are described in detail below.

Instructions are loaded into the TAP controller during the Shift-IR state when the instruction register is placed between TDI and TDO. During this state, instructions are shifted through the instruction register through the TDI and TDO balls. To execute the instruction once it is shifted in, the TAP controller needs to be moved into the Update-IR state.

IDCODE

The IDCODE instruction causes a vendor-specific, 32-bit code to be loaded into the instruction register. It also places the instruction register between the TDI and TDO balls and allows the IDCODE to be shifted out of the device when the TAP controller enters the Shift-DR state.

The IDCODE instruction is loaded into the instruction register upon power-up or whenever the TAP controller is given a test logic reset state.

SAMPLE Z

The SAMPLE Z instruction causes the boundary scan register to be connected between the TDI and TDO pins when the TAP controller is in a Shift-DR state. The SAMPLE Z command puts the output bus into a High-Z state until the next command is given during the "Update IR" state.

SAMPLE/PRELOAD

SAMPLE/PRELOAD is a 1149.1 mandatory instruction. When the SAMPLE/PRELOAD instructions are loaded into the instruction register and the TAP controller is in the Capture-DR state, a snapshot of data on the inputs and output pins is captured in the boundary scan register.

The user must be aware that the TAP controller clock can only operate at a frequency up to 20 MHz, while the SRAM clock operates more than an order of magnitude faster. Because there is a large difference in the clock frequencies, it is possible that during the Capture-DR state, an input or output will undergo a transition. The TAP may then try to capture a signal

while in transition (metastable state). This will not harm the device, but there is no guarantee as to the value that will be captured. Repeatable results may not be possible.

To guarantee that the boundary scan register will capture the correct value of a signal, the SRAM signal must be stabilized long enough to meet the TAP controller's capture set-up plus hold times (t_{CS} and t_{CH}). The SRAM clock input might not be captured correctly if there is no way in a design to stop (or slow) the clock during a SAMPLE/PRELOAD instruction. If this is an issue, it is still possible to capture all other signals and simply ignore the value of the CK and CK captured in the boundary scan register.

Once the data is captured, it is possible to shift out the data by putting the TAP into the Shift-DR state. This places the boundary scan register between the TDI and TDO pins.

PRELOAD allows an initial data pattern to be placed at the latched parallel outputs of the boundary scan register cells prior to the selection of another boundary scan test operation.

The shifting of data for the SAMPLE and PRELOAD phases can occur concurrently when required—that is, while data captured is shifted out, the preloaded data can be shifted in.

BYPASS

When the BYPASS instruction is loaded in the instruction register and the TAP is placed in a Shift-DR state, the bypass register is placed between the TDI and TDO pins. The advantage of the BYPASS instruction is that it shortens the boundary scan path when multiple devices are connected together on a board.

EXTEST

The EXTEST instruction enables the preloaded data to be driven out through the system output pins. This instruction also selects the boundary scan register to be connected for serial access between the TDI and TDO in the shift-DR controller state.

EXTEST OUTPUT BUS TRI-STATE

IEEE Standard 1149.1 mandates that the TAP controller be able to put the output bus into a tri-state mode.

The boundary scan register has a special bit located at , bit #89 (for 165-FBGA package) or bit #138 (for 209-fBGA package). When this scan cell, called the “extest output bus tristate”, is latched into the preload register during the “Update-DR” state in the TAP controller, it will directly control the state of the output (Q-bus) pins, when the EXTEST is entered as the current instruction. When HIGH, it will enable the output buffers to drive the output bus. When LOW, this bit will place the output bus into a High-Z condition.

This bit can be set by entering the SAMPLE/PRELOAD or EXTEST command, and then shifting the desired bit into that cell, during the “Shift-DR” state. During “Update-DR”, the value loaded into that shift-register cell will latch into the preload register. When the EXTEST instruction is entered, this bit will directly control the output Q-bus pins. Note that this bit is pre-set HIGH to enable the output when the device is powered-up, and also when the TAP controller is in the “Test-Logic-Reset” state.

Reserved

These instructions are not implemented but are reserved for future use. Do not use these instructions.

TAP Timing

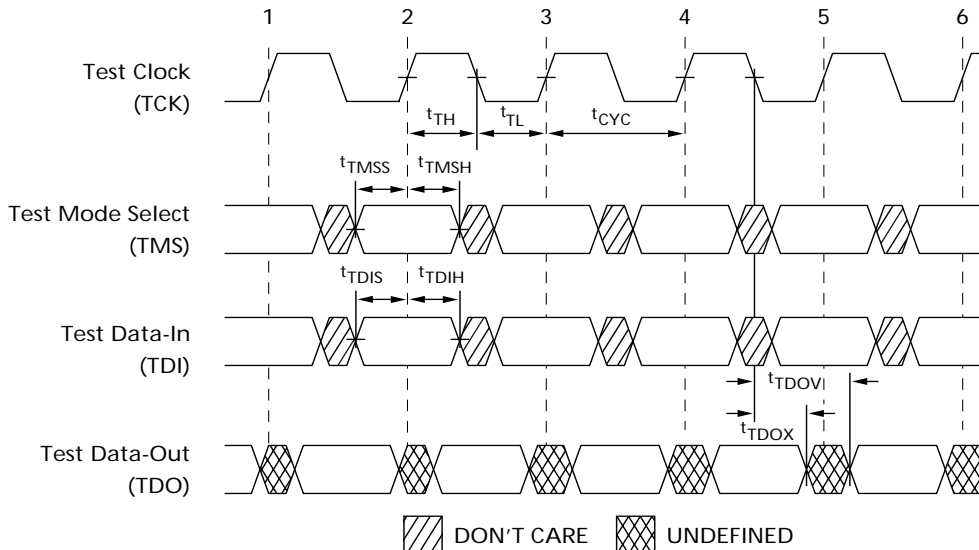

TAP AC Switching Characteristics Over the operating Range^[11, 12]

Parameter	Description	Min.	Max.	Unit
Clock				
t _{TCYC}	TCK Clock Cycle Time	50		ns
t _{TF}	TCK Clock Frequency		20	MHz
t _{TH}	TCK Clock HIGH time	25		ns
t _{TL}	TCK Clock LOW time	25		ns
Output Times				
t _{TDOV}	TCK Clock LOW to TDO Valid		5	ns
t _{TDOX}	TCK Clock LOW to TDO Invalid	0		ns
Set-up Times				
t _{TMSS}	TMS Set-up to TCK Clock Rise	5		ns
t _{TDIS}	TDI Set-up to TCK Clock Rise	5		ns
t _{CS}	Capture Set-up to TCK Rise	5		ns
Hold Times				
t _{TMSH}	TMS hold after TCK Clock Rise	5		ns
t _{TDIH}	TDI Hold after Clock Rise	5		ns
t _{CH}	Capture Hold after Clock Rise	5		ns

3.3V TAP AC Test Conditions

Input pulse levels V_{SS} to 3.3V
 Input rise and fall times 1ns
 Input timing reference levels 1.5V
 Output reference levels 1.5V
 Test load termination supply voltage 1.5V

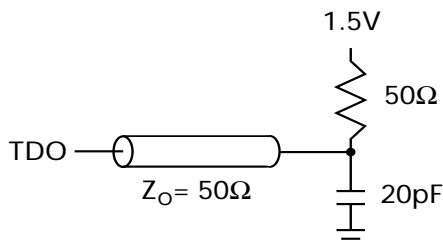
3.3V TAP AC Output Load Equivalent

2.5V TAP AC Test Conditions

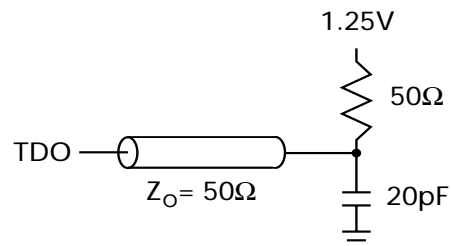
Input pulse levels V_{SS} to 2.5V
 Input rise and fall time 1 ns
 Input timing reference levels 1.25V
 Output reference levels 1.25V
 Test load termination supply voltage 1.25V

2.5V TAP AC Output Load Equivalent

Notes:

11. t_{CS} and t_{CH} refer to the set-up and hold time requirements of latching data from the boundary scan register.
 12. Test conditions are specified using the load in TAP AC test Conditions. t_R/t_F = ns.



TAP DC Electrical Characteristics And Operating Conditions

(0°C < TA < +70°C; V_{DD} = 3.135 to 3.6V unless otherwise noted)^[13]

Parameter	Description	Test Conditions	Min.	Max.	Unit
V _{OH1}	Output HIGH Voltage	I _{OH} = -4.0 mA, V _{DDQ} = 3.3V	2.4		V
		I _{OH} = -1.0 mA, V _{DDQ} = 2.5V	2.0		V
V _{OH2}	Output HIGH Voltage	I _{OH} = -100 μA	V _{DDQ} = 3.3V	2.9	V
			V _{DDQ} = 2.5V	2.1	V
V _{OL1}	Output LOW Voltage	I _{OL} = 8.0 mA	V _{DDQ} = 3.3V	0.4	V
		I _{OL} = 1.0 mA	V _{DDQ} = 2.5V	0.4	V
V _{OL2}	Output LOW Voltage	I _{OL} = 100 μA	V _{DDQ} = 3.3V	0.2	V
			V _{DDQ} = 2.5V	0.2	V
V _{IH}	Input HIGH Voltage		V _{DDQ} = 3.3V	2.0	V _{DD} + 0.3
			V _{DDQ} = 2.5V	1.7	V _{DD} + 0.3
V _{IL}	Input LOW Voltage		V _{DDQ} = 3.3V	-0.3	0.8
			V _{DDQ} = 2.5V	-0.3	0.7
I _X	Input Load Current	GND ≤ V _{IN} ≤ V _{DDQ}	-5	5	μA

Identification Register Definitions

Instruction Field	CY7C1440AV33 (1 Mbit x 36)	CY7C1442AV33 (2 Mbit x 18)	CY7C1446AV33 (512K x 72)	Description
Revision Number (31:29)	000	000	000	Describes the version number.
Device Depth (28:24) ^[14]	01011	01011	01011	Reserved for Internal Use
Architecture/Memory Type(23:18)	000000	000000	000000	Defines memory type and architecture
Bus Width/Density(17:12)	100111	010111	110111	Defines width and density
Cypress JEDEC ID Code (11:1)	00000110100	00000110100	00000110100	Allows unique identification of SRAM vendor.
ID Register Presence Indicator (0)	1	1	1	Indicates the presence of an ID register.

Scan Register Sizes

Register Name	Bit Size (x36)	Bit Size (x18)	Bit Size (x72)
Instruction	3	3	3
Bypass	1	1	1
ID	32	32	32
Boundary Scan Order-165FBGA	89	89	-
Boundary Scan Order-209fBGA	-	-	138

Identification Codes

Instruction	Code	Description
EXTEST	000	Captures the I/O ring contents.
IDCODE	001	Loads the ID register with the vendor ID code and places the register between TDI and TDO. This operation does not affect SRAM operations.
SAMPLE Z	010	Captures I/O ring contents. Places the boundary scan register between TDI and TDO. Forces all SRAM output drivers to a High-Z state.
RESERVED	011	Do Not Use: This instruction is reserved for future use.

Notes:

- 13. All voltages referenced to V_{SS} (GND).
- 14. Bit #24 is "1" in the ID Register Definitions for both 2.5V and 3.3V versions of this device.



Identification Codes (continued)

Instruction	Code	Description
SAMPLE/PRELOAD	100	Captures I/O ring contents. Places the boundary scan register between TDI and TDO. Does not affect SRAM operation.
RESERVED	101	Do Not Use: This instruction is reserved for future use.
RESERVED	110	Do Not Use: This instruction is reserved for future use.
BYPASS	111	Places the bypass register between TDI and TDO. This operation does not affect SRAM operations.

165-Ball fBGA Boundary Scan Order ^[15,16]

CY7C1440AV33 (1 Mbit x 36),CY7C1442AV33 (2 Mbit x 18)			
BIT#	BALL ID	BIT#	BALL ID
1	N6	46	B5
2	N7	47	A5
3	N10	48	A4
4	P11	49	B4
5	P8	50	B3
6	R8	51	A3
7	R9	52	A2
8	P9	53	B2
9	P10	54	C2
10	R10	55	B1
11	R11	56	A1
12	H11	57	C1
13	N11	58	D1
14	M11	59	E1
15	L11	60	F1
16	K11	61	G1
17	J11	62	D2
18	M10	63	E2
19	L10	64	F2
20	K10	65	G2
21	J10	66	H1
22	H9	67	H3
23	H10	68	J1

165-Ball fBGA Boundary Scan Order (continued)^[15,16]

CY7C1440AV33 (1 Mbit x 36),CY7C1442AV33 (2 Mbit x 18)			
BIT#	BALL ID	BIT#	BALL ID
24	G11	69	K1
25	F11	70	L1
26	E11	71	M1
27	D11	72	J2
28	G10	73	K2
29	F10	74	L2
30	E10	75	M2
31	D10	76	N1
32	C11	77	N2
33	A11	78	P1
34	B11	79	R1
35	A10	80	R2
36	B10	81	P3
37	A9	82	R3
38	B9	83	P2
39	C10	84	R4
40	A8	85	P4
41	B8	86	N5
42	A7	87	P6
43	B7	88	R6
44	B6	89	Internal
45	A6		

Notes:

- 15. Balls that are NC (No Connect) are preset LOW.
- 16. Bit# 89 is preset HIGH.



PRELIMINARY

**CY7C1440AV33
CY7C1442AV33
CY7C1446AV33**

209-Ball fBGA Boundary Scan Order [15,17]

CY7C1446AV33 (512K x 72)			
BIT#	BALL ID	BIT#	BALL ID
1	W6	42	H11
2	V6	43	H10
3	U6	44	G11
4	W7	45	G10
5	V7	46	F11
6	U7	47	F10
7	T7	48	E10
8	V8	49	E11
9	U8	50	D11
10	T8	51	D10
11	V9	52	C11
12	U9	53	C10
13	P6	54	B11
14	W11	55	B10
15	W10	56	A11
16	V11	57	A10
17	V10	58	C9
18	U11	59	B9
19	U10	60	A9
20	T11	61	D7
21	T10	62	C8
22	R11	63	B8
23	R10	64	A8
24	P11	65	D8
25	P10	66	C7
26	N11	67	B7
27	N10	68	A7
28	M11	69	D6
29	M10	70	G6
30	L11	71	H6
31	L10	72	C6
32	K11	73	B6
33	M6	74	A6
34	L6	75	A5
35	J6	76	B5

209-Ball fBGA Boundary Scan Order (continued) [15,17]

CY7C1446AV33 (512K x 72)			
BIT#	BALL ID	BIT#	BALL ID
36	F6	77	C5
37	K8	78	D5
38	K9	79	D4
39	K10	80	C4
40	J11	81	A4
41	J10	82	B4
83	C3	111	L1
84	B3	112	M2
85	A3	113	M1
86	A2	114	N2
87	A1	115	N1
88	B2	116	P2
89	B1	117	P1
90	C2	118	R2
91	C1	119	R1
92	D2	120	T2
93	D1	121	T1
94	E1	122	U2
95	E2	123	U1
96	F2	124	V2
97	F1	125	V1
98	G1	126	W2
99	G2	127	W1
100	H2	128	T6
101	H1	129	U3
102	J2	130	V3
103	J1	131	T4
104	K1	132	T5
105	N6	133	U4
106	K3	134	V4
107	K4	135	5W
108	K6	136	5V
109	K2	137	5U
110	L2	138	Internal

Note:
17. Bit# 138 is preset HIGH.



Maximum Ratings

(Above which the useful life may be impaired. For user guidelines, not tested.)

- Storage Temperature -65°C to +150°C
- Ambient Temperature with Power Applied..... -55°C to +125°C
- Supply Voltage on V_{DD} Relative to GND..... -0.3V to +4.6V
- DC Voltage Applied to Outputs in Tri-State..... -0.5V to V_{DDQ} + 0.5V
- DC Input Voltage..... -0.5V to V_{DD} + 0.5V

- Current into Outputs (LOW)..... 20 mA
- Static Discharge Voltage..... > 2001V (per MIL-STD-883, Method 3015)
- Latch-up Current..... > 200 mA

Operating Range

Range	Ambient Temperature	V _{DD}	V _{DDQ}
Commercial	0°C to +70°C	3.3V - 5%/+10%	2.5V - 5% to V _{DD}

Electrical Characteristics Over the Operating Range^[18, 19]

Parameter	Description	Test Conditions	Min.	Max.	Unit
V _{DD}	Power Supply Voltage		3.135	3.6	V
V _{DDQ}	I/O Supply Voltage	V _{DDQ} = 3.3V	3.135	V _{DD}	V
		V _{DDQ} = 2.5V	2.375	2.625	V
V _{OH}	Output HIGH Voltage	V _{DDQ} = 3.3V, V _{DD} = Min., I _{OH} = -4.0 mA	2.4		V
		V _{DDQ} = 2.5V, V _{DD} = Min., I _{OH} = -1.0 mA	2.0		V
V _{OL}	Output LOW Voltage	V _{DDQ} = 3.3V, V _{DD} = Max., I _{OL} = 8.0 mA		0.4	V
		V _{DDQ} = 2.5V, V _{DD} = Max., I _{OL} = 1.0 mA		0.4	V
V _{IH}	Input HIGH Voltage ^[18]	V _{DDQ} = 3.3V	2.0	V _{DD} + 0.3V	V
		V _{DDQ} = 2.5V	1.7	V _{DD} + 0.3V	V
V _{IL}	Input LOW Voltage ^[18]	V _{DDQ} = 3.3V	-0.3	0.8	V
		V _{DDQ} = 2.5V	-0.3	0.7	V
I _X	Input Load Current except ZZ and MODE	GND ≤ V _I ≤ V _{DDQ}	-5	5	μA
		Input = V _{SS}	-5		μA
	Input Current of MODE	Input = V _{DD}		30	μA
		Input Current of ZZ	Input = V _{SS}	-30	
		Input = V _{DD}		5	μA
I _{OZ}	Output Leakage Current	GND ≤ V _I ≤ V _{DDQ} , Output Disabled	-5	5	μA
I _{DD}	V _{DD} Operating Supply Current	V _{DD} = Max., I _{OUT} = 0 mA, f = f _{MAX} = 1/t _{CYC}	4.0-ns cycle, 250 MHz	475	mA
			5.0-ns cycle, 200 MHz	425	mA
			6.0-ns cycle, 167 MHz	375	mA
I _{SB1}	Automatic CE Power-down Current—TTL Inputs	V _{DD} = Max, Device Deselected, V _{IN} ≥ V _{IH} or V _{IN} ≤ V _{IL} , f = f _{MAX} = 1/t _{CYC}	4.0-ns cycle, 250 MHz	225	mA
			5.0-ns cycle, 200 MHz	225	mA
			6.0-ns cycle, 167 MHz	225	mA
I _{SB2}	Automatic CE Power-down Current—CMOS Inputs	V _{DD} = Max, Device Deselected, V _{IN} ≤ 0.3V or V _{IN} ≥ V _{DDQ} - 0.3V, f = 0	All speeds	100	mA
I _{SB3}	Automatic CE Power-down Current—CMOS Inputs	V _{DD} = Max, Device Deselected, or V _{IN} ≤ 0.3V or V _{IN} ≥ V _{DDQ} - 0.3V, f = f _{MAX} = 1/t _{CYC}	4.0-ns cycle, 250 MHz	200	mA
			5.0-ns cycle, 200 MHz	200	mA
			6.0-ns cycle, 167 MHz	200	mA
I _{SB4}	Automatic CE Power-down Current—TTL Inputs	V _{DD} = Max, Device Deselected, V _{IN} ≥ V _{IH} or V _{IN} ≤ V _{IL} , f = 0	All speeds	110	mA

Shaded areas contain advance information.

Notes:

- 18. Overshoot: V_{IH}(AC) < V_{DD} + 1.5V (Pulse width less than t_{CYC}/2), undershoot: V_{IL}(AC) > -2V (Pulse width less than t_{CYC}/2).
- 19. T_{Power-up}: Assumes a linear ramp from 0V to V_{DD}(min.) within 200 ms. During this time V_{IH} ≤ V_{DD} and V_{DDQ} ≤ V_{DD}.

Thermal Resistance^[20]

Parameter	Description	Test Conditions	100 TQFP Package	165 BGA Package	209 fBGA Package	Unit
Θ_{JA}	Thermal Resistance (Junction to Ambient)	Test conditions follow standard test methods and procedures for measuring thermal impedance, per EIA / JESD51.	25.21	20.8	25.31	°C/W
Θ_{JC}	Thermal Resistance (Junction to Case)		2.28	3.2	4.48	°C/W

Capacitance^[20]

Parameter	Description	Test Conditions	100 TQFP Package	165 BGA Package	209 fBGA Package	Unit
C_{IN}	Input Capacitance	$T_A = 25^\circ\text{C}$, $f = 1\text{ MHz}$, $V_{DD} = 3.3\text{V}$, $V_{DDQ} = 2.5\text{V}$	6.5	5	5	pF
C_{CLK}	Clock Input Capacitance		3	5	5	pF
$C_{I/O}$	Input/Output Capacitance		5.5	7	7	pF

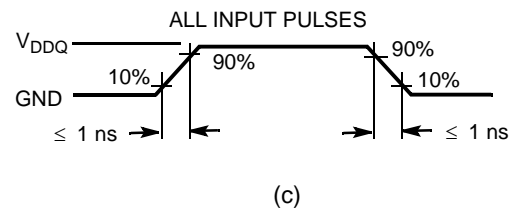
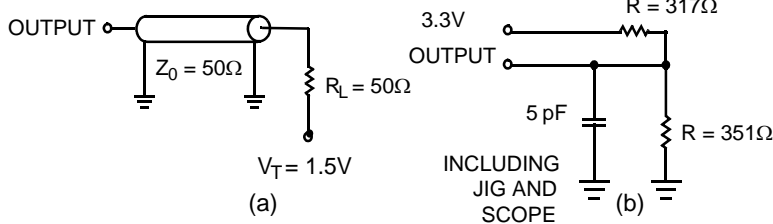
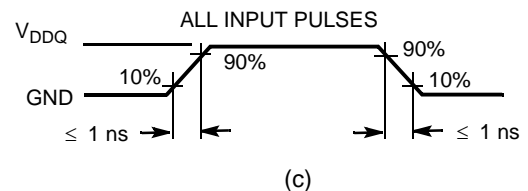
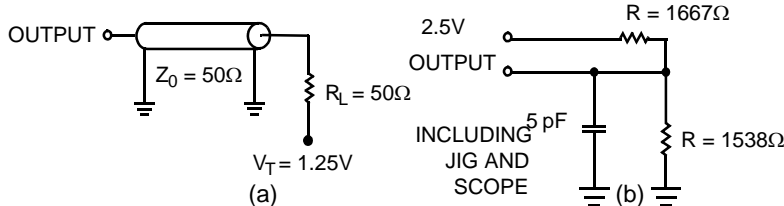
AC Test Loads and Waveforms
3.3V I/O Test Load

2.5V I/O Test Load

Switching Characteristics Over the Operating Range^[25, 26]

Parameter	Description	250 MHz		200 MHz		167 MHz		Unit
		Min.	Max.	Min.	Max.	Min.	Max.	
t_{POWER}	$V_{DD}(\text{Typical})$ to the first Access ^[21]	1		1		1		ms
Clock								
t_{CYC}	Clock Cycle Time	4.0		5		6		ns
t_{CH}	Clock HIGH	1.5		2.0		2.4		ns
t_{CL}	Clock LOW	1.5		2.0		2.4		ns
Output Times								
t_{CO}	Data Output Valid After CLK Rise		2.6		3.2		3.4	ns
t_{DOH}	Data Output Hold After CLK Rise	1.0		1.5		1.5		ns
t_{CLZ}	Clock to Low-Z ^[22, 23, 24]	1.0		1.3		1.5		ns

Notes:

20. Tested initially and after any design or process change that may affect these parameters.
21. This part has a voltage regulator internally; t_{POWER} is the time that the power needs to be supplied above $V_{DD}(\text{minimum})$ initially before a read or write operation can be initiated.
22. t_{CHZ} , t_{CLZ} , t_{OELZ} , and t_{OEZH} are specified with AC test conditions shown in (b) of AC Test Loads. Transition is measured $\pm 200\text{ mV}$ from steady-state voltage.
23. At any given voltage and temperature, t_{OEZH} is less than t_{OELZ} and t_{CHZ} is less than t_{CLZ} to eliminate bus contention between SRAMs when sharing the same data bus. These specifications do not imply a bus contention condition, but reflect parameters guaranteed over worst case user conditions. Device is designed to achieve High-Z prior to Low-Z under the same system conditions
24. This parameter is sampled and not 100% tested.
25. Timing reference level is 1.5V when $V_{DDQ} = 3.3\text{V}$ and is 1.25V when $V_{DDQ} = 2.5\text{V}$.
26. Test conditions shown in (a) of AC Test Loads unless otherwise noted.



Switching Characteristics Over the Operating Range (continued)^[25, 26]

Parameter	Description	250 MHz		200 MHz		167 MHz		Unit
		Min.	Max	Min.	Max.	Min.	Max	
t _{CHZ}	Clock to High-Z ^[22, 23, 24]		2.6		3.0		3.4	ns
t _{OEV}	OE LOW to Output Valid		2.6		3.0		3.4	ns
t _{OELZ}	OE LOW to Output Low-Z ^[22, 23, 24]	0		0		0		ns
t _{OEHZ}	OE HIGH to Output High-Z ^[22, 23, 24]		2.6		3.0		3.4	ns
Set-up Times								
t _{AS}	Address Set-up Before CLK Rise	1.2		1.4		1.5		ns
t _{ADS}	ADSC, ADSP Set-up Before CLK Rise	1.2		1.4		1.5		ns
t _{ADVS}	ADV Set-up Before CLK Rise	1.2		1.4		1.5		ns
t _{WES}	GW, BWE, BW _X Set-up Before CLK Rise	1.2		1.4		1.5		ns
t _{DS}	Data Input Set-up Before CLK Rise	1.2		1.4		1.5		ns
t _{CES}	Chip Enable Set-up Before CLK Rise	1.2		1.4		1.5		ns
Hold Times								
t _{AH}	Address Hold After CLK Rise	0.3		0.4		0.5		ns
t _{ADH}	ADSP, ADSC Hold After CLK Rise	0.3		0.4		0.5		ns
t _{ADVH}	ADV Hold After CLK Rise	0.3		0.4		0.5		ns
t _{WEH}	GW, BWE, BW _X Hold After CLK Rise	0.3		0.4		0.5		ns
t _{DH}	Data Input Hold After CLK Rise	0.3		0.4		0.5		ns
t _{CEH}	Chip Enable Hold After CLK Rise	0.3		0.4		0.5		ns

Shaded areas contain advance information.

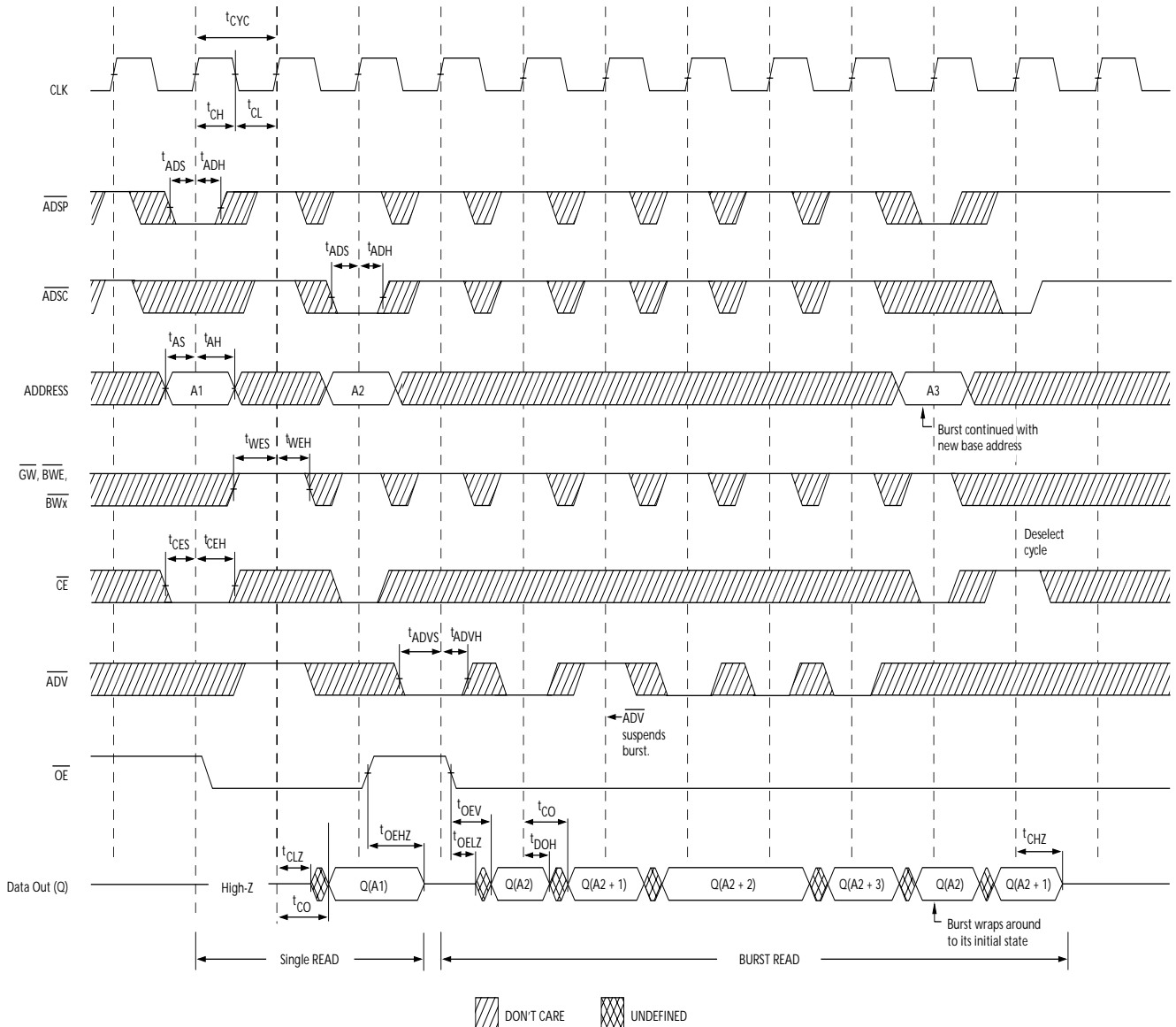
Switching Waveforms
Read Cycle Timing^[27]

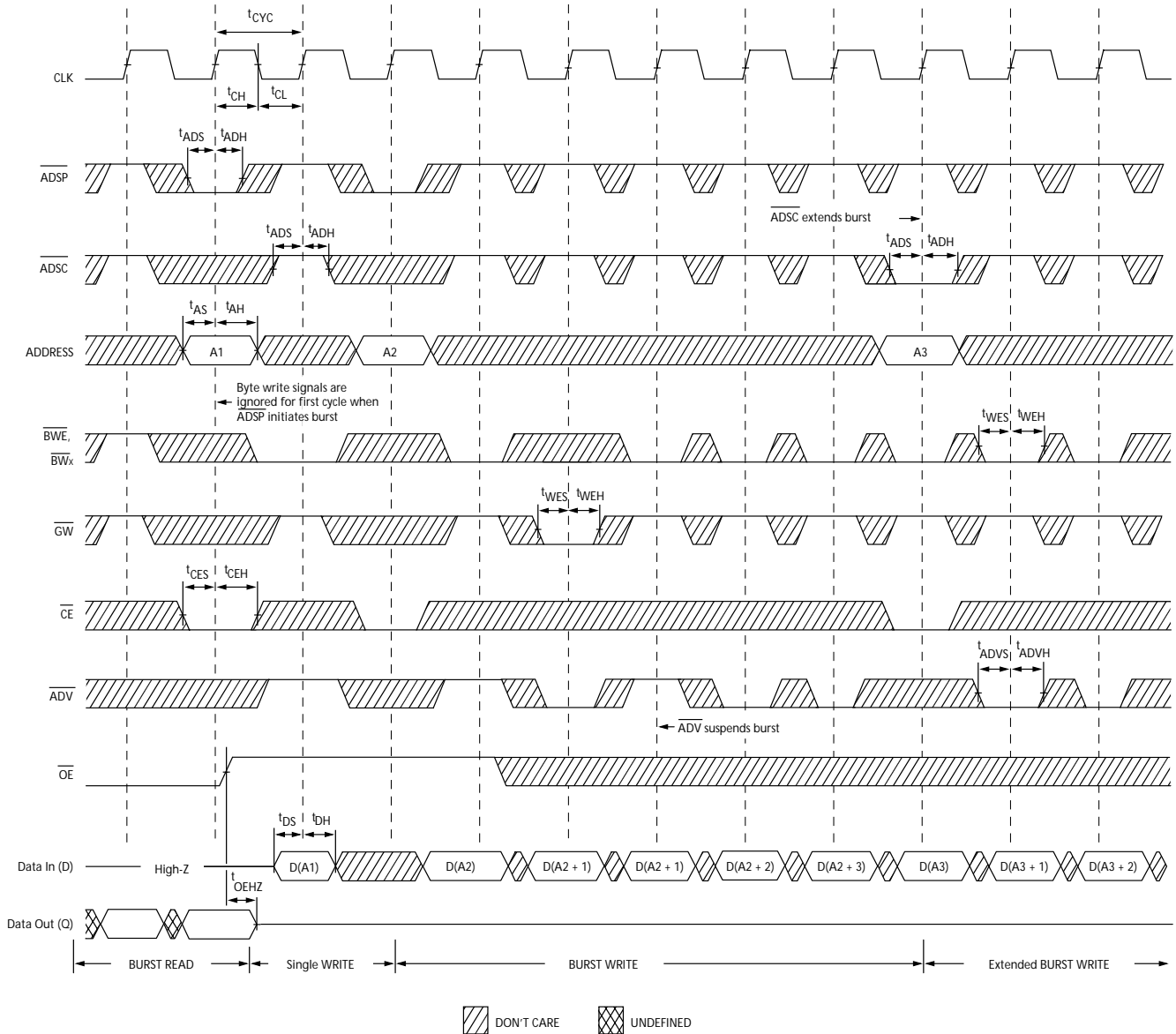
Switching Waveforms (continued)
Write Cycle Timing^[27, 28]

Note:
28. Full width write can be initiated by either \overline{GW} LOW; or by \overline{GW} HIGH, \overline{BWE} LOW and \overline{BW}_x LOW.

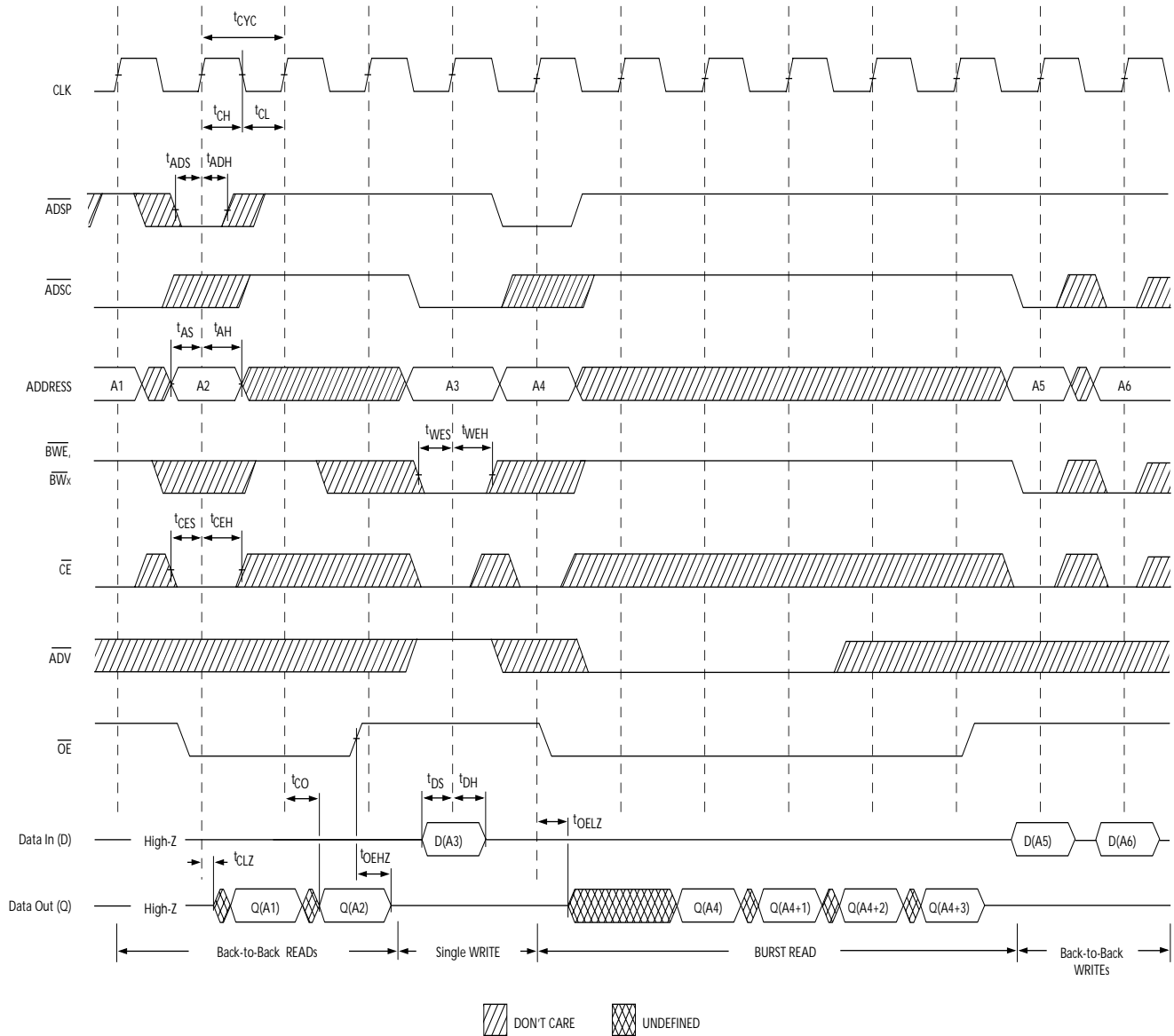
Switching Waveforms (continued)
Read/Write Cycle Timing^[27, 29, 30]

Notes:

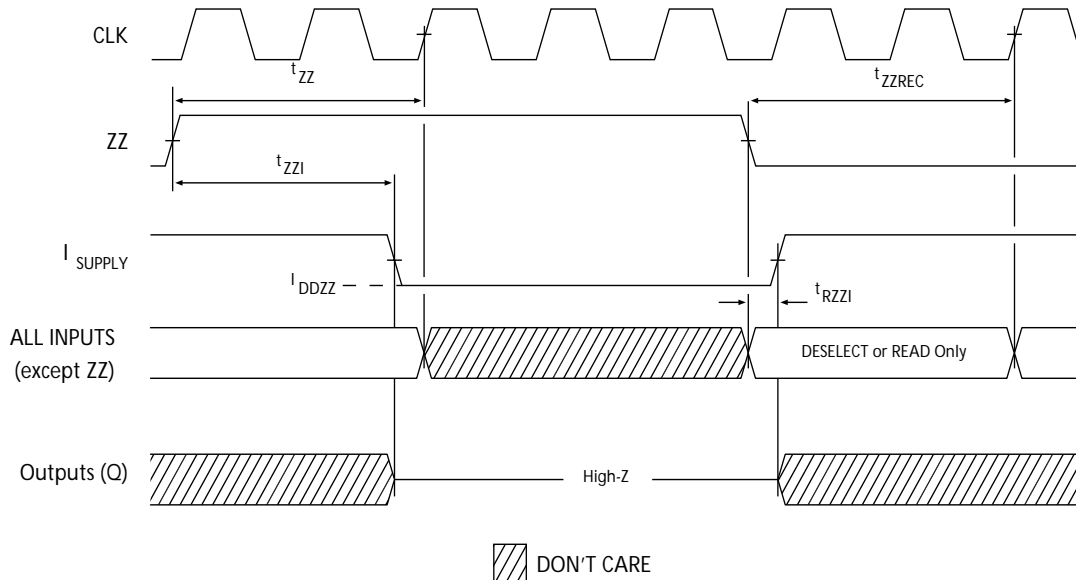
29. The data bus (Q) remains in high-Z following a Write cycle, unless a new read access is initiated by \overline{ADSP} or \overline{ADSC} .
 30. GW is HIGH.

Switching Waveforms (continued)
ZZ Mode Timing^[32, 33]

Ordering Information

Speed (MHz)	Ordering Code	Package Name	Part and Package Type	Operating Range
250	CY7C1440AV33-250AXC CY7C1442AV33-250AXC	A101	Lead-Free 100-lead 14 x 20 x 1.4 mm Thin Quad Flat Pack	Commercial
	CY7C1440AV33-250BZC CY7C1442AV33-250BZC	BB165C	165-ball Fine Pitch Ball Grid Array (15 x 17 x 1.4 mm)	
	CY7C1446AV33-250BGC	BB209A	209-ball Ball Grid Array (14 x 22 x 1.76 mm)	
	CY7C1440AV33-250BZXC CY7C1442AV33-250BZXC	BB165C	Lead-Free 165-ball Fine Pitch Ball Grid Array (15 x 17 x 1.4 mm)	
	CY7C1446AV33-250BGXC	BB209A	Lead-Free 209-ball Ball Grid Array (14 x 22 x 1.76 mm)	
200	CY7C1440AV33-200AXC CY7C1442AV33-200AXC	A101	Lead-Free 100-lead 14 x 20 x 1.4 mm Thin Quad Flat Pack	
	CY7C1440AV33-200BZC CY7C1442AV33-200BZC	BB165C	165-ball Fine Pitch Ball Grid Array (15 x 17 x 1.4 mm)	
	CY7C1446AV33-200BGC	BB209A	209-ball Ball Grid Array (14 x 22 x 1.76 mm)	
	CY7C1440AV33-200BZXC CY7C1442AV33-200BZXC	BB165C	Lead-Free 165-ball Fine Pitch Ball Grid Array (15 x 17 x 1.4 mm)	
	CY7C1446AV33-200BGXC	BB209A	Lead-Free 209-ball Ball Grid Array (14 x 22 x 1.76 mm)	

Shaded areas contain advance information. Please contact your local sales representative for availability of these parts.

32. Device must be deselected when entering ZZ mode. See Cycle Descriptions table for all possible signal conditions to deselect the device.

33. DQs are in high-Z when exiting ZZ sleep mode.

Ordering Information (continued)

Speed (MHz)	Ordering Code	Package Name	Part and Package Type	Operating Range
167	CY7C1440AV33-167AXC CY7C1442AV33-167AXC	A101	Lead-Free 100-lead 14 x 20 x 1.4 mm Thin Quad Flat Pack	Commercial
	CY7C1440AV33-167BZC CY7C1442AV33-167BZC	BB165C	165-ball Fine Pitch Ball Grid Array (15 x 17 x 1.4 mm)	
	CY7C1446AV33-167BGC	BB209A	209-ball Ball Grid Array (14 x 22 x 1.76 mm)	
	CY7C1440AV33-167BZXC CY7C1442AV33-167BZXC	BB165C	Lead-Free 165-ball Fine Pitch Ball Grid Array (15 x 17 x 1.4 mm)	
	CY7C1446AV33-167BGXC	BB209A	Lead-Free 209-ball Ball Grid Array (14 x 22 x 1.76 mm)	

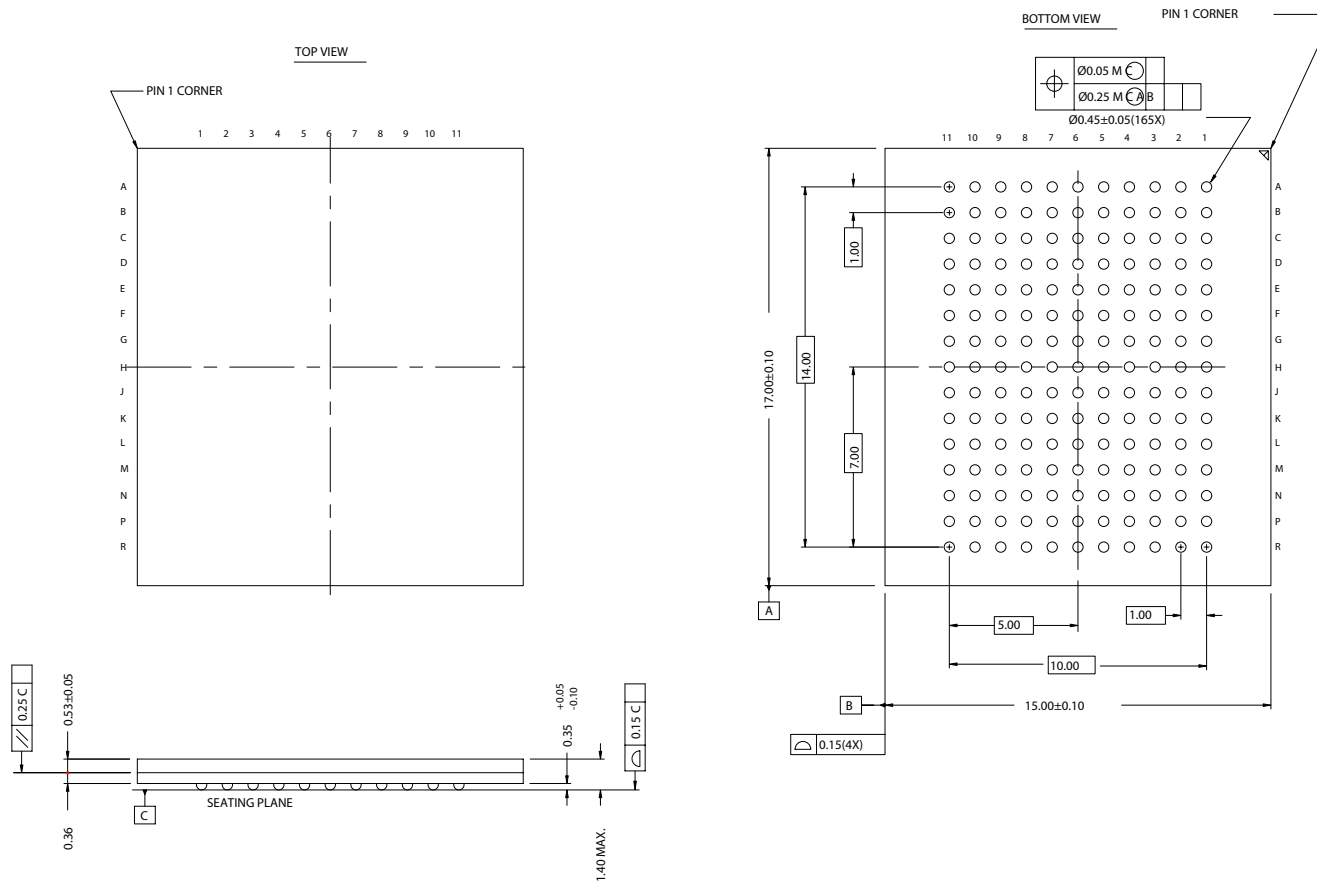
Package Diagrams
165-Ball FBGA (15 x 17 x 1.40 mm) BB165C

51-85165-*A

Package Diagrams (continued)

209-Ball FBGA (14 x 22 x 1.76 mm) BB209A

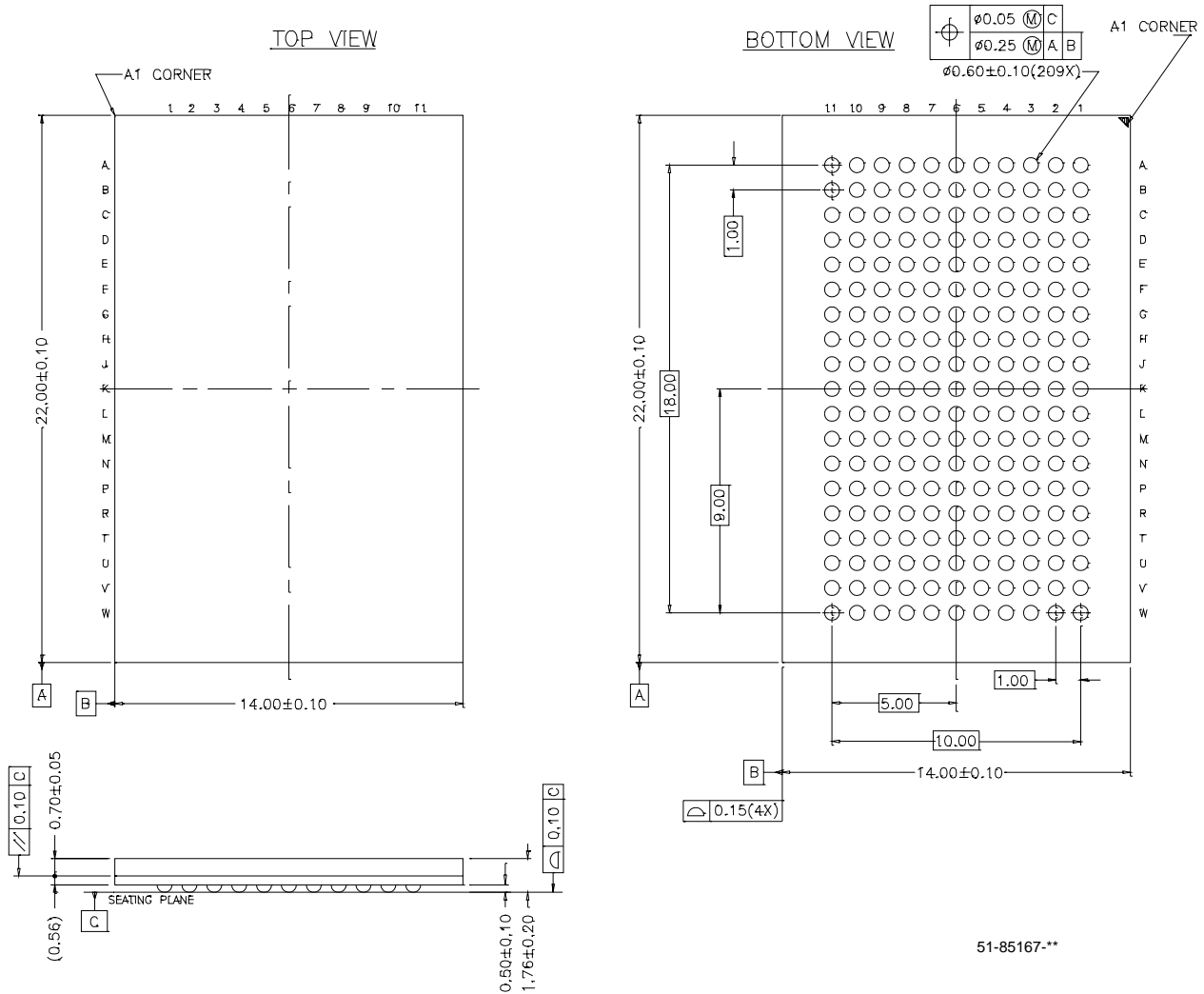

51-85167-**

i486 is a trademark, and Intel and Pentium are registered trademarks of Intel Corporation. PowerPC is a trademark of IBM Corporation. All product and company names mentioned in this document are the trademarks of their respective holders.



Document History Page

Document Title: CY7C1440AV33/CY7C1442AV33/CY7C1446AV33 36-Mbit (1M x 36/2M x 18/512K x 72) Pipelined Sync SRAM				
Document Number: 38-05383				
REV.	ECN NO.	Issue Date	Orig. of Change	Description of Change
**	124437	03/04/03	CJM	New data sheet
*A	254910	See ECN	SYT	Part number changed from previous revision. New and old part number differ by the letter "A" Modified Functional Block diagrams Modified switching waveforms Added Boundary scan information Added Footnote #14 (32-Bit Vendor ID Code changed) Added I _{DD} , I _X and I _{SB} values in the DC Electrical Characteristics Added t _{POWER} specifications in Switching Characteristics table Removed 119 PBGA package Changed 165 FBGA package from BB165C (15 x 17 x 1.20 mm) to BB165 (15 x 17 x 1.40 mm) Changed 209-Lead PBGA BG209 (14 x 22 x 2.20 mm) to BB209A (14 x 22 x 1.76 mm)
*B	306335	See ECN	SYT	Changed H9 pin from V _{SSQ} to V _{SS} on the Pin Configuration table for 209 FBGA on Page # 6 Changed t _{CO} from 3.0 to 3.2 ns and t _{DOH} from 1.3 ns to 1.5 ns for 200 Mhz speed bin on the Switching Characteristics table on Page # 19 Changed Θ _{JA} and Θ _{JC} from TBD to 25.21 and 2.58 °C/W respectively for TQFP Package on Pg # 19 Replaced Θ _{JA} and Θ _{JC} from TBD to respective Values for 165 BGA and 209 fBGA Packages on the Thermal Resistance Table Added lead-free information for 100-Pin TQFP, 165 FBGA and 209 fBGA Packages . Changed I _{DD} from 450, 400 and 350 mA to 475, 425 and 375 mA for frequencies of 250, 200 and 167 MHz respectively Changed I _{SB1} from 190, 180 and 170 mA to 225 mA for frequencies of 250, 200 and 167 MHz respectively Changed I _{SB2} from 80 to 100 mA Changed I _{SB3} from 180, 170 and 160 mA to 200 mA for frequencies of 250, 200 and 167 MHz respectively Changed I _{SB4} from 100 to 110 mA