

# 36-Mbit (2 M × 18) Flow-Through SRAM with NoBL™ Architecture

## Features

- No Bus Latency™ (NoBL™) architecture eliminates dead cycles between write and read cycles
- Supports up to 133-MHz bus operations with zero wait states
  - Data is transferred on every clock
- Pin-compatible and functionally equivalent to ZBT™ devices
- Internally self timed output buffer control to eliminate the need to use OE
- Registered inputs for flow through operation
- Byte Write capability
- 3.3 V/2.5 V I/O power supply
- Fast clock-to-output times
  - 6.5 ns (for 133-MHz device)
- Clock Enable ( $\overline{CEN}$ ) pin to enable clock and suspend operation
- Synchronous self timed writes
- Asynchronous Output Enable
- CY7C1463BV33 available in JEDEC-standard Pb-free 100-pin TQFP package
- Three chip enables for simple depth expansion
- Automatic Power down feature available using ZZ mode or CE deselect
- Burst Capability — linear or interleaved burst order
- Low standby power

## Functional Description

The CY7C1463BV33 is a 3.3 V, 2 M × 18 Synchronous Flow-through Burst SRAM designed specifically to support unlimited true back-to-back Read/Write operations without the insertion of wait states. The CY7C1463BV33 is equipped with the advanced No Bus Latency (NoBL) logic required to enable consecutive Read/Write operations with data being transferred on every clock cycle. This feature dramatically improves the throughput of data through the SRAM, especially in systems that require frequent Write-Read transitions.

All synchronous inputs pass through input registers controlled by the rising edge of the clock. The clock input is qualified by the Clock Enable ( $\overline{CEN}$ ) signal, which when deasserted suspends operation and extends the previous clock cycle. Maximum access delay from the clock rise is 6.5 ns (133-MHz device).

Write operations are controlled by the two or four Byte Write Select ( $BW_x$ ) and a Write Enable ( $\overline{WE}$ ) input. All writes are conducted with on-chip synchronous self timed write circuitry.

Three synchronous Chip Enables ( $\overline{CE}_1$ ,  $\overline{CE}_2$ ,  $\overline{CE}_3$ ) and an asynchronous Output Enable ( $\overline{OE}$ ) provide for easy bank selection and output tri-state control. To avoid bus contention, the output drivers are synchronously tri-stated during the data portion of a write sequence.

For a complete list of related documentation, click [here](#).

## Selection Guide

| Description                  | 133 MHz | Unit |
|------------------------------|---------|------|
| Maximum Access Time          | 6.5     | ns   |
| Maximum Operating Current    | 310     | mA   |
| Maximum CMOS Standby Current | 120     | mA   |

Logic Block Diagram – CY7C1463BV33

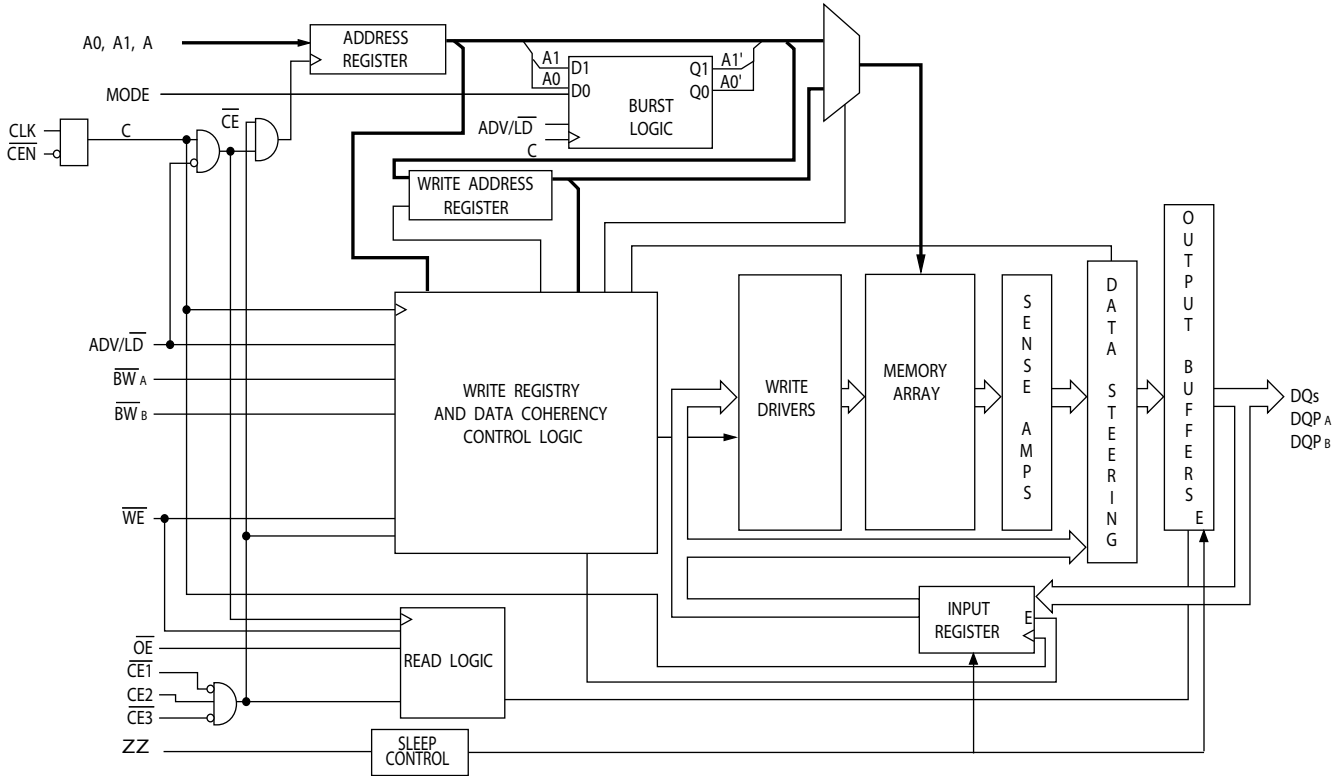

## Contents

|  |           |  |           |
|--|-----------|--|-----------|
| <b>Pin Configurations</b> .....          | <b>4</b>  | <b>Thermal Resistance</b> .....                      | <b>10</b> |
| <b>Pin Definitions</b> .....             | <b>5</b>  | <b>AC Test Loads and Waveforms</b> .....             | <b>10</b> |
| <b>Functional Overview</b> .....         | <b>6</b>  | <b>Switching Characteristics</b> .....               | <b>11</b> |
| Single Read Accesses .....               | 6         | <b>Switching Waveforms</b> .....                     | <b>12</b> |
| Burst Read Accesses .....                | 6         | <b>Ordering Information</b> .....                    | <b>15</b> |
| Single Write Accesses .....              | 6         | Ordering Code Definitions .....                      | 15        |
| Burst Write Accesses .....               | 7         | <b>Package Diagram</b> .....                         | <b>16</b> |
| Sleep Mode .....                         | 7         | <b>Acronyms</b> .....                                | <b>17</b> |
| Interleaved Burst Address Table .....    | 7         | <b>Document Conventions</b> .....                    | <b>17</b> |
| Linear Burst Address Table .....         | 7         | Units of Measure .....                               | 17        |
| ZZ Mode Electrical Characteristics ..... | 7         | <b>Document History Page</b> .....                   | <b>18</b> |
| <b>Truth Table</b> .....                 | <b>8</b>  | <b>Sales, Solutions, and Legal Information</b> ..... | <b>19</b> |
| <b>Truth Table for Read/Write</b> .....  | <b>8</b>  | Worldwide Sales and Design Support .....             | 19        |
| <b>Maximum Ratings</b> .....             | <b>9</b>  | Products .....                                       | 19        |
| <b>Operating Range</b> .....             | <b>9</b>  | PSoC® Solutions .....                                | 19        |
| <b>Neutron Soft Error Immunity</b> ..... | <b>9</b>  | Cypress Developer Community .....                    | 19        |
| <b>Electrical Characteristics</b> .....  | <b>9</b>  | Technical Support .....                              | 19        |
| <b>Capacitance</b> .....                 | <b>10</b> |  |           |

**Pin Configurations**

**Figure 1. 100-pin TQFP (14 × 20 × 1.4 mm) pinout**

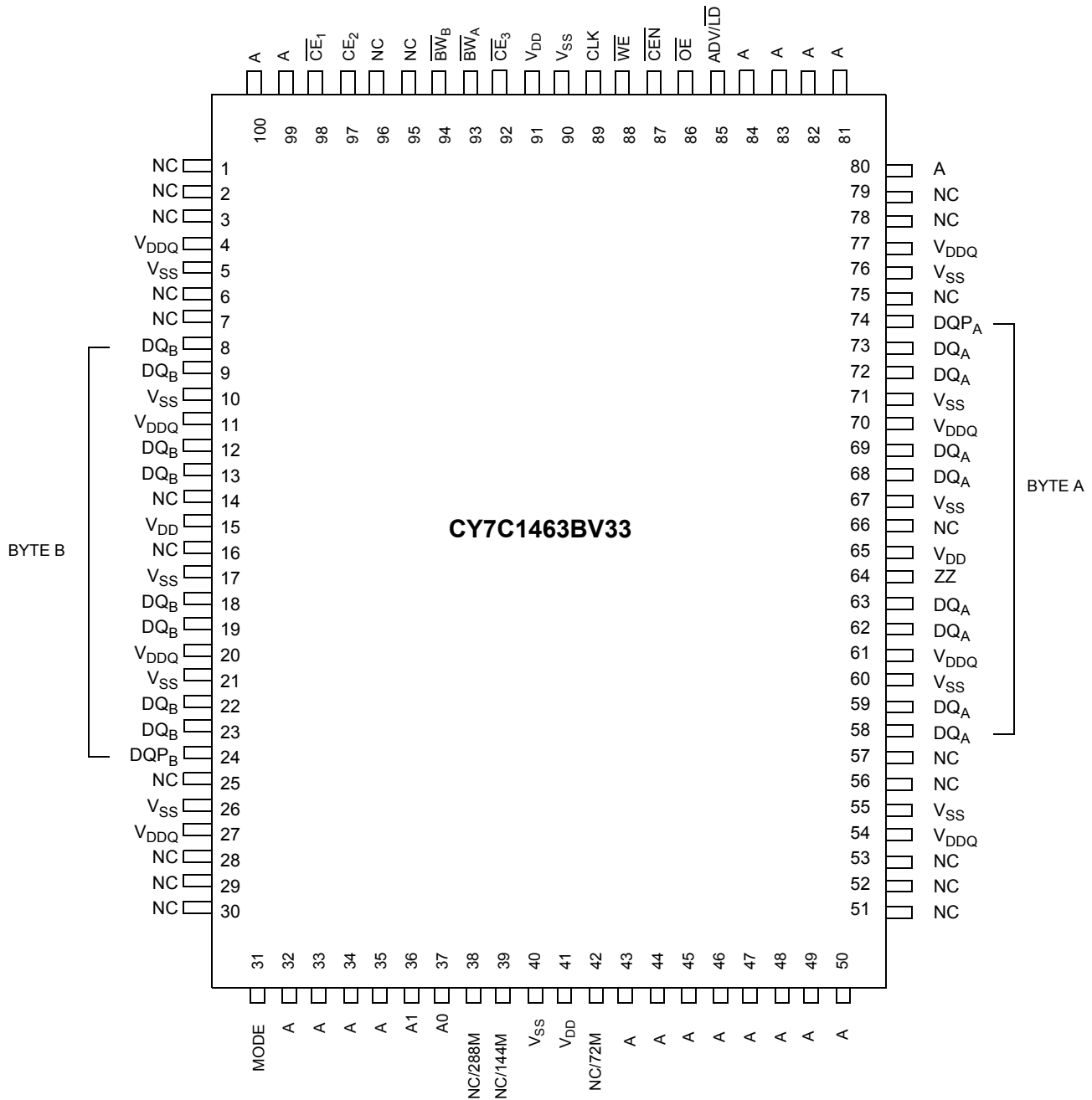

## Pin Definitions

| Name                               | I/O                | Description  |
|------------------------------------|--------------------|--|
| $A_0, A_1, A$                      | Input-Synchronous  | <b>Address Inputs Used to Select one of the Address Locations.</b> Sampled at the rising edge of the CLK. $A_{[1:0]}$ are fed to the two-bit burst counter.  |
| $\overline{BW}_A, \overline{BW}_B$ | Input-Synchronous  | <b>Byte Write Inputs, Active LOW.</b> Qualified with $\overline{WE}$ to conduct writes to the SRAM. Sampled on the rising edge of CLK.   |
| $\overline{WE}$                    | Input-Synchronous  | <b>Write Enable Input, Active LOW.</b> Sampled on the rising edge of CLK if $\overline{CEN}$ is active LOW. This signal must be asserted LOW to initiate a write sequence.   |
| $ADV/\overline{LD}$                | Input-Synchronous  | <b>Advance/Load Input.</b> Used to advance the on-chip address counter or load a new address. When HIGH (and $\overline{CEN}$ is asserted LOW) the internal burst counter is advanced. When LOW, a new address can be loaded into the device for an access. After being deselected, $ADV/\overline{LD}$ must be driven LOW to load a new address.  |
| CLK                                | Input-Clock        | <b>Clock Input.</b> Used to capture all synchronous inputs to the device. CLK is qualified with $\overline{CEN}$ . CLK is only recognized if $\overline{CEN}$ is active LOW.   |
| $\overline{CE}_1$                  | Input-Synchronous  | <b>Chip Enable 1 Input, Active LOW.</b> Sampled on the rising edge of CLK. Used in conjunction with $CE_2$ and $CE_3$ to select/deselect the device.   |
| $CE_2$                             | Input-Synchronous  | <b>Chip Enable 2 Input, Active HIGH.</b> Sampled on the rising edge of CLK. Used in conjunction with $\overline{CE}_1$ and $\overline{CE}_3$ to select/deselect the device.  |
| $\overline{CE}_3$                  | Input-Synchronous  | <b>Chip Enable 3 Input, Active LOW.</b> Sampled on the rising edge of CLK. Used in conjunction with $\overline{CE}_1$ and $CE_2$ to select/deselect the device.  |
| $\overline{OE}$                    | Input-Asynchronous | <b>Output Enable, Asynchronous Input, Active LOW.</b> Combined with the synchronous logic block inside the device to control the direction of the I/O pins. When LOW, the I/O pins are allowed to behave as outputs. When deasserted HIGH, I/O pins are tri-stated, and act as input data pins. $\overline{OE}$ is masked during the data portion of a write sequence, during the first clock when emerging from a deselected state, when the device is deselected.  |
| $\overline{CEN}$                   | Input-Synchronous  | <b>Clock Enable Input, Active LOW.</b> When asserted LOW the Clock signal is recognized by the SRAM. When deasserted HIGH the Clock signal is masked. Since deasserting $\overline{CEN}$ does not deselect the device, use $\overline{CEN}$ to extend the previous cycle when required.  |
| ZZ                                 | Input-Asynchronous | <b>ZZ "Sleep" Input.</b> This active HIGH input places the device in a non-time critical "sleep" condition with data integrity preserved. During normal operation, this pin must be LOW or left floating. ZZ pin has an internal pull down.  |
| $DQ_s$                             | I/O-Synchronous    | <b>Bidirectional Data I/O Lines.</b> As inputs, they feed into an on-chip data register that is triggered by the rising edge of CLK. As outputs, they deliver the data contained in the memory location specified by the addresses presented during the previous clock rise of the read cycle. The direction of the pins is controlled by $\overline{OE}$ . When $\overline{OE}$ is asserted LOW, the pins behave as outputs. When HIGH, $DQ_s$ and $DQP_{[A:B]}$ are placed in a tri-state condition. The outputs are automatically tri-stated during the data portion of a write sequence, during the first clock when emerging from a deselected state, and when the device is deselected, regardless of the state of $\overline{OE}$ . |
| $DQP_x$                            | I/O-Synchronous    | <b>Bidirectional Data Parity I/O Lines.</b> Functionally, these signals are identical to $DQ_s$ . During write sequences, $DQP_x$ is controlled by $\overline{BW}_x$ correspondingly.  |
| MODE                               | Input Strap Pin    | <b>Mode Input. Selects the Burst Order of the Device.</b> When tied to GND selects linear burst sequence. When tied to $V_{DD}$ or left floating selects interleaved burst sequence.   |
| $V_{DD}$                           | Power Supply       | <b>Power Supply Inputs to the Core of the Device.</b>  |
| $V_{DDQ}$                          | I/O Power Supply   | <b>Power Supply for the I/O Circuitry.</b>   |
| $V_{SS}$                           | Ground             | <b>Ground for the Device.</b>  |
| NC                                 | N/A                | <b>No Connects.</b> Not internally connected to the die.   |
| NC/72M                             | N/A                | <b>Not Connected to the Die.</b> Can be tied to any voltage level.   |

**Pin Definitions** (continued)

| Name    | I/O | Description  |
|---------|-----|--|
| NC/144M | N/A | <b>Not Connected to the Die.</b> Can be tied to any voltage level. |
| NC/288M | N/A | <b>Not Connected to the Die.</b> Can be tied to any voltage level. |
| NC/576M | N/A | <b>Not Connected to the Die.</b> Can be tied to any voltage level. |
| NC/1G   | N/A | <b>Not Connected to the Die.</b> Can be tied to any voltage level. |

**Functional Overview**

The CY7C1463BV33 is a synchronous flow through burst SRAM designed specifically to eliminate wait states during Write-Read transitions. All synchronous inputs pass through input registers controlled by the rising edge of the clock. The clock signal is qualified with the Clock Enable input signal ( $\overline{CEN}$ ). If  $\overline{CEN}$  is HIGH, the clock signal is not recognized and all internal states are maintained. All synchronous operations are qualified with  $\overline{CEN}$ . Maximum access delay from the clock rise ( $t_{CDV}$ ) is 6.5 ns (133-MHz device).

Accesses can be initiated by asserting all three Chip Enables ( $\overline{CE}_1$ ,  $\overline{CE}_2$ ,  $\overline{CE}_3$ ) active at the rising edge of the clock. If Clock Enable ( $\overline{CEN}$ ) is active LOW and  $\overline{ADV/LD}$  is asserted LOW, the address presented to the device is latched. The access can either be a read or write operation, depending on the status of the Write Enable ( $\overline{WE}$ ).  $\overline{BW}_X$  can be used to conduct byte write operations.

Write operations are qualified by the Write Enable ( $\overline{WE}$ ). All writes are simplified with on-chip synchronous self timed write circuitry.

Three synchronous Chip Enables ( $\overline{CE}_1$ ,  $\overline{CE}_2$ ,  $\overline{CE}_3$ ) and an asynchronous Output Enable ( $\overline{OE}$ ) simplify depth expansion. All operations (Reads, Writes, and Deselects) are pipelined.  $\overline{ADV/LD}$  must be driven LOW after the device has been deselected to load a new address for the next operation.

**Single Read Accesses**

A read access is initiated when these conditions are satisfied at clock rise:

- $\overline{CEN}$  is asserted LOW
- $\overline{CE}_1$ ,  $\overline{CE}_2$ , and  $\overline{CE}_3$  are ALL asserted active
- The Write Enable input signal  $\overline{WE}$  is deasserted HIGH
- $\overline{ADV/LD}$  is asserted LOW.

The address presented to the address inputs is latched into the Address Register and presented to the memory array and control logic. The control logic determines that a read access is in progress and allows the requested data to propagate to the output buffers. The data is available within 6.5 ns (133-MHz device) provided  $\overline{OE}$  is active LOW. After the first clock of the read access, the output buffers are controlled by  $\overline{OE}$  and the internal control logic.  $\overline{OE}$  must be driven LOW in order for the device to drive out the requested data. On the subsequent clock, another operation (Read/Write/Deselect) can be initiated. When the SRAM is deselected at clock rise by one of the chip enable signals, its output is tri-stated immediately.

**Burst Read Accesses**

The CY7C1463BV33 has an on-chip burst counter that allows the user the ability to supply a single address and conduct up to four Reads without reasserting the address inputs.  $\overline{ADV/LD}$  must be driven LOW to load a new address into the SRAM, as described in [Single Read Accesses](#). The sequence of the burst counter is determined by the MODE input signal. A LOW input on MODE selects a linear burst mode, a HIGH selects an interleaved burst sequence. Both burst counters use A0 and A1 in the burst sequence, and wraps around when incremented sufficiently. A HIGH input on  $\overline{ADV/LD}$  increments the internal burst counter regardless of the state of chip enable inputs or  $\overline{WE}$ .  $\overline{WE}$  is latched at the beginning of a burst cycle. Therefore, the type of access (Read or Write) is maintained throughout the burst sequence.

**Single Write Accesses**

Write access are initiated when the following conditions are satisfied at clock rise: (1)  $\overline{CEN}$  is asserted LOW, (2)  $\overline{CE}_1$ ,  $\overline{CE}_2$ , and  $\overline{CE}_3$  are ALL asserted active, and (3) the write signal  $\overline{WE}$  is asserted LOW. The address presented to the address bus is loaded into the Address Register. The write signals are latched into the Control Logic block. The data lines are automatically tri-stated regardless of the state of the  $\overline{OE}$  input signal. This allows the external logic to present the data on DQs and  $\overline{DQP}_X$ .

On the next clock rise the data presented to DQs and  $\overline{DQP}_X$  (or a subset for byte write operations, see truth table for details) inputs is latched into the device and the write is complete. Additional accesses (Read/Write/Deselect) can be initiated on this cycle.

The data written during the Write operation is controlled by  $\overline{BW}_X$  signals. The CY7C1463BV33 provides byte write capability that is described in the truth table. Asserting the Write Enable input ( $\overline{WE}$ ) with the selected Byte Write Select input selectively writes to only the desired bytes. Bytes not selected during a byte write operation remains unaltered. A synchronous self timed write mechanism has been provided to simplify the write operations. Byte write capability has been included to greatly simplify Read/Modify/Write sequences, which can be reduced to simple byte write operations.

Because the CY7C1463BV33 is a common I/O device, data must not be driven into the device while the outputs are active. The Output Enable ( $\overline{OE}$ ) can be deasserted HIGH before presenting data to the DQs and  $\overline{DQP}_X$  inputs. Doing so tri-states the output drivers. As a safety precaution, DQs and  $\overline{DQP}_X$  are automatically tri-stated during the data portion of a write cycle, regardless of the state of  $\overline{OE}$ .

### Burst Write Accesses

The CY7C1463BV33 has an on-chip burst counter that allows the user the ability to supply a single address and conduct up to four Write operations without reasserting the address inputs. ADV/LD must be driven LOW to load the initial address, as described in [Single Write Accesses on page 6](#). When ADV/LD is driven HIGH on the subsequent clock rise, the Chip Enables ( $\overline{CE}_1$ ,  $\overline{CE}_2$ , and  $\overline{CE}_3$ ) and  $\overline{WE}$  inputs are ignored and the burst counter is incremented. The correct  $\overline{BW}_X$  inputs must be driven in each cycle of the burst write, to write the correct bytes of data.

### Sleep Mode

The ZZ input pin is an asynchronous input. Asserting ZZ places the SRAM in a power conservation “sleep” mode. Two clock cycles are required to enter into or exit from this “sleep” mode. While in this mode, data integrity is guaranteed. Accesses pending when entering the “sleep” mode are not considered valid nor is the completion of the operation guaranteed. The device must be deselected prior to entering the “sleep” mode.  $\overline{CE}_1$ ,  $\overline{CE}_2$ , and  $\overline{CE}_3$ , must remain inactive for the duration of  $t_{ZZREC}$  after the ZZ input returns LOW.

### Interleaved Burst Address Table

(MODE = Floating or  $V_{DD}$ )

| First Address A1:A0 | Second Address A1:A0 | Third Address A1:A0 | Fourth Address A1:A0 |
|---------------------|----------------------|---------------------|----------------------|
| 00                  | 01                   | 10                  | 11                   |
| 01                  | 00                   | 11                  | 10                   |
| 10                  | 11                   | 00                  | 01                   |
| 11                  | 10                   | 01                  | 00                   |

### Linear Burst Address Table

(MODE = GND)

| First Address A1:A0 | Second Address A1:A0 | Third Address A1:A0 | Fourth Address A1:A0 |
|---------------------|----------------------|---------------------|----------------------|
| 00                  | 01                   | 10                  | 11                   |
| 01                  | 10                   | 11                  | 00                   |
| 10                  | 11                   | 00                  | 01                   |
| 11                  | 00                   | 01                  | 10                   |

### ZZ Mode Electrical Characteristics

| Parameter   | Description                       | Test Conditions           | Min        | Max        | Unit |
|-------------|-----------------------------------|---------------------------|------------|------------|------|
| $I_{DDZZ}$  | Sleep mode standby current        | $ZZ \geq V_{DD} - 0.2 V$  | –          | 100        | mA   |
| $t_{ZZS}$   | Device operation to ZZ            | $ZZ \geq V_{DD} - 0.2 V$  | –          | $2t_{CYC}$ | ns   |
| $t_{ZZREC}$ | ZZ recovery time                  | $ZZ \leq 0.2 V$           | $2t_{CYC}$ | –          | ns   |
| $t_{ZZI}$   | ZZ active to sleep current        | This parameter is sampled | –          | $2t_{CYC}$ | ns   |
| $t_{RZZI}$  | ZZ Inactive to exit sleep current | This parameter is sampled | 0          | –          | ns   |

## Truth Table

The truth table for CY7C1463BV33 follows. [1, 2, 3, 4, 5, 6, 7]

| Operation                     | Address Used | $\overline{CE}_1$ | $\overline{CE}_2$ | $\overline{CE}_3$ | ZZ | ADV/LD | $\overline{WE}$ | $\overline{BW}_x$ | OE | CEN | CLK  | DQ           |
|-------------------------------|--------------|-------------------|-------------------|-------------------|----|--------|-----------------|-------------------|----|-----|------|--------------|
| Deselect Cycle                | None         | H                 | X                 | X                 | L  | L      | X               | X                 | X  | L   | L->H | Tri-State    |
| Deselect Cycle                | None         | X                 | X                 | H                 | L  | L      | X               | X                 | X  | L   | L->H | Tri-State    |
| Deselect Cycle                | None         | X                 | L                 | X                 | L  | L      | X               | X                 | X  | L   | L->H | Tri-State    |
| Continue Deselect Cycle       | None         | X                 | X                 | X                 | L  | H      | X               | X                 | X  | L   | L->H | Tri-State    |
| Read Cycle (Begin Burst)      | External     | L                 | H                 | L                 | L  | L      | H               | X                 | L  | L   | L->H | Data Out (Q) |
| Read Cycle (Continue Burst)   | Next         | X                 | X                 | X                 | L  | H      | X               | X                 | L  | L   | L->H | Data Out (Q) |
| NOP/Dummy Read (Begin Burst)  | External     | L                 | H                 | L                 | L  | L      | H               | X                 | H  | L   | L->H | Tri-State    |
| Dummy Read (Continue Burst)   | Next         | X                 | X                 | X                 | L  | H      | X               | X                 | H  | L   | L->H | Tri-State    |
| Write Cycle (Begin Burst)     | External     | L                 | H                 | L                 | L  | L      | L               | L                 | X  | L   | L->H | Data In (D)  |
| Write Cycle (Continue Burst)  | Next         | X                 | X                 | X                 | L  | H      | X               | L                 | X  | L   | L->H | Data In (D)  |
| NOP/Write Abort (Begin Burst) | None         | L                 | H                 | L                 | L  | L      | L               | H                 | X  | L   | L->H | Tri-State    |
| Write Abort (Continue Burst)  | Next         | X                 | X                 | X                 | L  | H      | X               | H                 | X  | L   | L->H | Tri-State    |
| Ignore Clock Edge (Stall)     | Current      | X                 | X                 | X                 | L  | X      | X               | X                 | X  | H   | L->H | -            |
| Sleep Mode                    | None         | X                 | X                 | X                 | H  | X      | X               | X                 | X  | X   | X    | Tri-State    |

## Truth Table for Read/Write

The read/write truth table for CY7C1463BV33 follows. [1, 8]

| Function (CY7C1463BV33)                                | $\overline{WE}$ | $\overline{BW}_b$ | $\overline{BW}_a$ |
|--|-----------------|-------------------|-------------------|
| Read   | H               | X                 | X                 |
| Write – No Bytes Written                               | L               | H                 | H                 |
| Write Byte a – (DQ <sub>a</sub> and DQP <sub>a</sub> ) | L               | H                 | L                 |
| Write Byte b – (DQ <sub>b</sub> and DQP <sub>b</sub> ) | L               | L                 | H                 |
| Write Both Bytes                                       | L               | L                 | L                 |

### Notes

1. X = "Don't Care." H = Logic HIGH, L = Logic LOW.  $\overline{BW}_x$  = L signifies at least one Byte Write Select is active,  $\overline{BW}_x$  = Valid signifies that the desired byte write selects are asserted, see truth table for details.
2. Write is defined by  $\overline{BW}_x$ , and  $\overline{WE}$ . See truth table for Read/Write.
3. When a write cycle is detected, all I/Os are tri-stated, even during byte writes.
4. The DQs and DQP<sub>x</sub> pins are controlled by the current cycle and the OE signal. OE is asynchronous and is not sampled with the clock.
5. CEN = H, inserts wait states.
6. Device powers up deselected and the I/Os in a tri-state condition, regardless of OE.
7. OE is asynchronous and is not sampled with the clock rise. It is masked internally during write cycles. During a read cycle DQs and DQP<sub>x</sub> = Tri-state when OE is inactive or when the device is deselected, and DQs and DQP<sub>x</sub> = data when OE is active.
8. Table only lists a partial listing of the byte write combinations. Any Combination of  $\overline{BW}_x$  is valid Appropriate write is done based on which byte write is active.



## Maximum Ratings

Exceeding maximum ratings may impair the useful life of the device. These user guidelines are not tested.

|   |                                    |
|---|------------------------------------|
| Storage Temperature .....                                 | -65 °C to +150 °C                  |
| Ambient Temperature with Power Applied .....              | -55 °C to +125 °C                  |
| Supply Voltage on V <sub>DD</sub> Relative to GND .....   | -0.5 V to +4.6 V                   |
| Supply Voltage on V <sub>DDQ</sub> Relative to GND .....  | -0.5 V to +V <sub>DD</sub>         |
| DC Voltage Applied to Outputs in Tri-State .....          | -0.5 V to V <sub>DDQ</sub> + 0.5 V |
| DC Input Voltage .....                                    | -0.5 V to V <sub>DD</sub> + 0.5 V  |
| Current into Outputs (LOW) .....                          | 20 mA                              |
| Static Discharge Voltage (MIL-STD-883, Method 3015) ..... | > 2001 V                           |
| Latch-up Current .....                                    | > 200 mA                           |

## Operating Range

| Range      | Ambient Temperature | V <sub>DD</sub>    | V <sub>DDQ</sub>              |
|------------|---------------------|--------------------|-------------------------------|
| Industrial | -40 °C to +85 °C    | 3.3 V – 5% / + 10% | 2.5 V – 5% to V <sub>DD</sub> |

## Neutron Soft Error Immunity

| Parameter | Description               | Test Conditions | Typ | Max* | Unit    |
|-----------|---------------------------|-----------------|-----|------|---------|
| LSBU      | Logical Single-Bit Upsets | 25 °C           | 197 | 216  | FIT/Mb  |
| LMBU      | Logical Multi-Bit Upsets  | 25 °C           | 0   | 0.01 | FIT/Mb  |
| SEL       | Single Event Latch-up     | 85 °C           | 0   | 0.1  | FIT/Dev |

\* No LMBU or SEL events occurred during testing; this column represents a statistical  $\chi^2$ , 95% confidence limit calculation. For more details refer to Application Note AN54908 "Accelerated Neutron SER Testing and Calculation of Terrestrial Failure Rates"

## Electrical Characteristics

Over the Operating Range

| Parameter <sup>[9, 10]</sup>    | Description                              | Test Conditions  | Min   | Max                     | Unit |
|---------------------------------|--|--|-------|-------------------------|------|
| V <sub>DD</sub>                 | Power Supply Voltage                     |  | 3.135 | 3.6                     | V    |
| V <sub>DDQ</sub>                | I/O Supply Voltage                       | for 3.3 V I/O  | 3.135 | V <sub>DD</sub>         | V    |
|                                 |  | for 2.5 V I/O  | 2.375 | 2.625                   | V    |
| V <sub>OH</sub>                 | Output HIGH Voltage                      | for 3.3 V I/O, I <sub>OH</sub> = -4.0 mA   | 2.4   | -                       | V    |
|                                 |  | for 2.5 V I/O, I <sub>OH</sub> = -1.0 mA   | 2.0   | -                       | V    |
| V <sub>OL</sub>                 | Output LOW Voltage                       | for 3.3 V I/O, I <sub>OL</sub> = 8.0 mA  | -     | 0.4                     | V    |
|                                 |  | for 2.5 V I/O, I <sub>OL</sub> = 1.0 mA  | -     | 0.4                     | V    |
| V <sub>IH</sub>                 | Input HIGH Voltage <sup>[9]</sup>        | for 3.3 V I/O  | 2.0   | V <sub>DD</sub> + 0.3 V | V    |
|                                 |  | for 2.5 V I/O  | 1.7   | V <sub>DD</sub> + 0.3 V | V    |
| V <sub>IL</sub>                 | Input LOW Voltage <sup>[9]</sup>         | for 3.3 V I/O  | -0.3  | 0.8                     | V    |
|                                 |  | for 2.5 V I/O  | -0.3  | 0.7                     | V    |
| I <sub>X</sub>                  | Input Leakage Current except ZZ and MODE | GND ≤ V <sub>I</sub> ≤ V <sub>DDQ</sub>  | -5    | 5                       | μA   |
|                                 | Input Current of MODE                    | Input = V <sub>SS</sub>  | -30   | -                       | μA   |
|                                 |  | Input = V <sub>DD</sub>  | -     | 5                       | μA   |
|                                 | Input Current of ZZ                      | Input = V <sub>SS</sub>  | -5    | -                       | μA   |
| Input = V <sub>DD</sub>         |  | -  | 30    | μA                      |      |
| I <sub>OZ</sub>                 | Output Leakage Current                   | GND ≤ V <sub>I</sub> ≤ V <sub>DDQ</sub> , Output Disabled                                  | -5    | 5                       | μA   |
| I <sub>DD</sub> <sup>[11]</sup> | V <sub>DD</sub> Operating Supply Current | V <sub>DD</sub> = Max., I <sub>OUT</sub> = 0 mA, f = f <sub>MAX</sub> = 1/t <sub>CYC</sub> |       |                         |      |
|                                 |  | 7.5 ns cycle, 133 MHz  | -     | 310                     | mA   |

### Notes

- Overshoot: V<sub>IH(AC)</sub> < V<sub>DD</sub> + 1.5 V (Pulse width less than t<sub>CYC</sub>/2), undershoot: V<sub>IL(AC)</sub> > -2 V (Pulse width less than t<sub>CYC</sub>/2).
- T<sub>Power-up</sub>: Assumes a linear ramp from 0 V to V<sub>DD(min)</sub> within 200 ms. During this time V<sub>IH</sub> < V<sub>DD</sub> and V<sub>DDQ</sub> ≤ V<sub>DD</sub>.
- The operation current is calculated with 50% read cycle and 50% write cycle.

**Electrical Characteristics** (continued)

Over the Operating Range

| Parameter <sup>[9, 10]</sup> | Description                                   | Test Conditions  | Min | Max | Unit |
|------------------------------|---|--|-----|-----|------|
| $I_{SB1}$                    | Automatic CE Power down Current – TTL Inputs  | $V_{DD} = \text{Max}$ , Device Deselected, $V_{IN} \geq V_{IH}$ or $V_{IN} \leq V_{IL}$ , $f = f_{MAX}$ , inputs switching                         | –   | 180 | mA   |
| $I_{SB2}$                    | Automatic CE Power down Current – CMOS Inputs | $V_{DD} = \text{Max}$ , Device Deselected, $V_{IN} \leq 0.3 \text{ V}$ or $V_{IN} \geq V_{DD} - 0.3 \text{ V}$ , $f = 0$ , inputs static           | –   | 120 | mA   |
| $I_{SB3}$                    | Automatic CE Power down Current – CMOS Inputs | $V_{DD} = \text{Max}$ , Device Deselected, $V_{IN} \leq 0.3 \text{ V}$ or $V_{IN} \geq V_{DDQ} - 0.3 \text{ V}$ , $f = f_{MAX}$ , inputs switching | –   | 180 | mA   |
| $I_{SB4}$                    | Automatic CE Power down Current – TTL Inputs  | $V_{DD} = \text{Max}$ , Device Deselected, $V_{IN} \geq V_{DD} - 0.3 \text{ V}$ or $V_{IN} \leq 0.3 \text{ V}$ , $f = 0$ , inputs static           | –   | 135 | mA   |

**Capacitance**

| Parameter <sup>[12]</sup> | Description              | Test Conditions   | 100-pin TQFP Max | Unit |
|---------------------------|--------------------------|---|------------------|------|
| $C_{IN}$                  | Input Capacitance        | $T_A = 25^\circ\text{C}$ , $f = 1 \text{ MHz}$ , $V_{DD} = 3.3 \text{ V}$ , $V_{DDQ} = 2.5 \text{ V}$ | 6.5              | pF   |
| $C_{CLK}$                 | Clock Input Capacitance  |   | 3                | pF   |
| $C_{IO}$                  | Input/Output Capacitance |   | 5.5              | pF   |

**Thermal Resistance**

| Parameter <sup>[12]</sup> | Description                              | Test Conditions   | 100-pin TQFP Package | Unit               |
|---------------------------|--|---|----------------------|--------------------|
| $\Theta_{JA}$             | Thermal Resistance (Junction to Ambient) | Test conditions follow standard test methods and procedures for measuring thermal impedance, according to EIA/JESD51. | 25.21                | $^\circ\text{C/W}$ |
| $\Theta_{JC}$             | Thermal Resistance (Junction to Case)    |   | 2.28                 | $^\circ\text{C/W}$ |

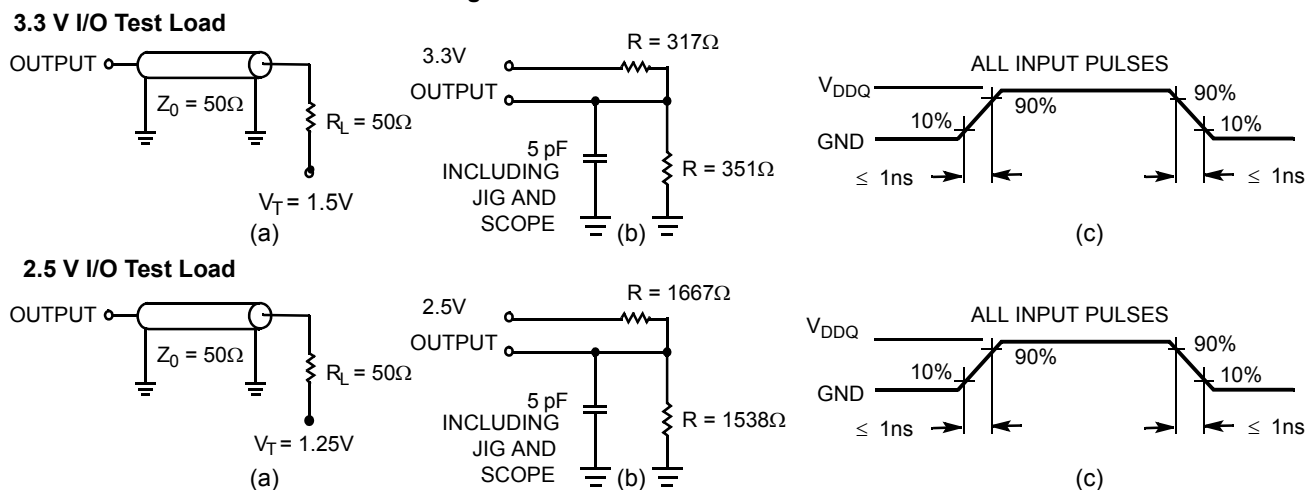
**AC Test Loads and Waveforms**
**Figure 2. AC Test Loads and Waveforms**

**Note**

12. Tested initially and after any design or process change that may affect these parameters.

## Switching Characteristics

Over the Operating Range

| Parameter [13, 14]  | Description                                   | 133 MHz |     | Unit |
|---------------------|---|---------|-----|------|
|                     |   | Min     | Max |      |
| $t_{POWER}^{[15]}$  | $V_{DD}(\text{typical})$ to the First Access  | 1       | –   | ms   |
| <b>Clock</b>        |   |         |     |      |
| $t_{CYC}$           | Clock Cycle Time                              | 7.5     | –   | ns   |
| $t_{CH}$            | Clock HIGH                                    | 2.5     | –   | ns   |
| $t_{CL}$            | Clock LOW                                     | 2.5     | –   | ns   |
| <b>Output Times</b> |   |         |     |      |
| $t_{CDV}$           | Data Output Valid After CLK Rise              | –       | 6.5 | ns   |
| $t_{DOH}$           | Data Output Hold After CLK Rise               | 2.5     | –   | ns   |
| $t_{CLZ}$           | Clock to Low Z [16, 17, 18]                   | 2.5     | –   | ns   |
| $t_{CHZ}$           | Clock to High Z [16, 17, 18]                  | –       | 3.8 | ns   |
| $t_{OE\bar{V}}$     | $\bar{O}E$ LOW to Output Valid                | –       | 3.0 | ns   |
| $t_{OE\bar{L}Z}$    | $\bar{O}E$ LOW to Output Low Z [16, 17, 18]   | 0       | –   | ns   |
| $t_{OE\bar{H}Z}$    | $\bar{O}E$ HIGH to Output High Z [16, 17, 18] | –       | 3.0 | ns   |
| <b>Setup Times</b>  |   |         |     |      |
| $t_{AS}$            | Address Setup Before CLK Rise                 | 1.5     | –   | ns   |
| $t_{ALS}$           | ADV/LD Setup Before CLK Rise                  | 1.5     | –   | ns   |
| $t_{WES}$           | $\bar{W}E, \bar{B}W_X$ Setup Before CLK Rise  | 1.5     | –   | ns   |
| $t_{CENS}$          | $\bar{C}EN$ Setup Before CLK Rise             | 1.5     | –   | ns   |
| $t_{DS}$            | Data Input Setup Before CLK Rise              | 1.5     | –   | ns   |
| $t_{CES}$           | Chip Enable Setup Before CLK Rise             | 1.5     | –   | ns   |
| <b>Hold Times</b>   |   |         |     |      |
| $t_{AH}$            | Address Hold After CLK Rise                   | 0.5     | –   | ns   |
| $t_{ALH}$           | ADV/LD Hold After CLK Rise                    | 0.5     | –   | ns   |
| $t_{WEH}$           | $\bar{W}E, \bar{B}W_X$ Hold After CLK Rise    | 0.5     | –   | ns   |
| $t_{CENH}$          | $\bar{C}EN$ Hold After CLK Rise               | 0.5     | –   | ns   |
| $t_{DH}$            | Data Input Hold After CLK Rise                | 0.5     | –   | ns   |
| $t_{CEH}$           | Chip Enable Hold After CLK Rise               | 0.5     | –   | ns   |

### Notes

13. Timing reference level is 1.5 V when  $V_{DDQ} = 3.3$  V and is 1.25 V when  $V_{DDQ} = 2.5$  V.

14. Test conditions shown in (a) of [Figure 2 on page 10](#) unless otherwise noted.

15. This part has a voltage regulator internally;  $t_{POWER}$  is the time that the power is supplied above  $V_{DD(\text{minimum})}$  initially, before a read or write operation can be initiated.

16.  $t_{CHZ}$ ,  $t_{CLZ}$ ,  $t_{OE\bar{L}Z}$ , and  $t_{OE\bar{H}Z}$  are specified with AC test conditions shown in part (b) of [Figure 2 on page 10](#). Transition is measured  $\pm 200$  mV from steady-state voltage.

17. At any voltage and temperature,  $t_{OE\bar{H}Z}$  is less than  $t_{OE\bar{L}Z}$  and  $t_{CHZ}$  is less than  $t_{CLZ}$  to eliminate bus contention between SRAMs when sharing the same data bus.

These specifications do not imply a bus contention condition, but reflect parameters guaranteed over worst case user conditions. Device is designed to achieve

High Z prior to Low Z under the same system conditions.

18. This parameter is sampled and not 100% tested.

### Switching Waveforms

Figure 3. Read/Write Waveforms [19, 20, 21]

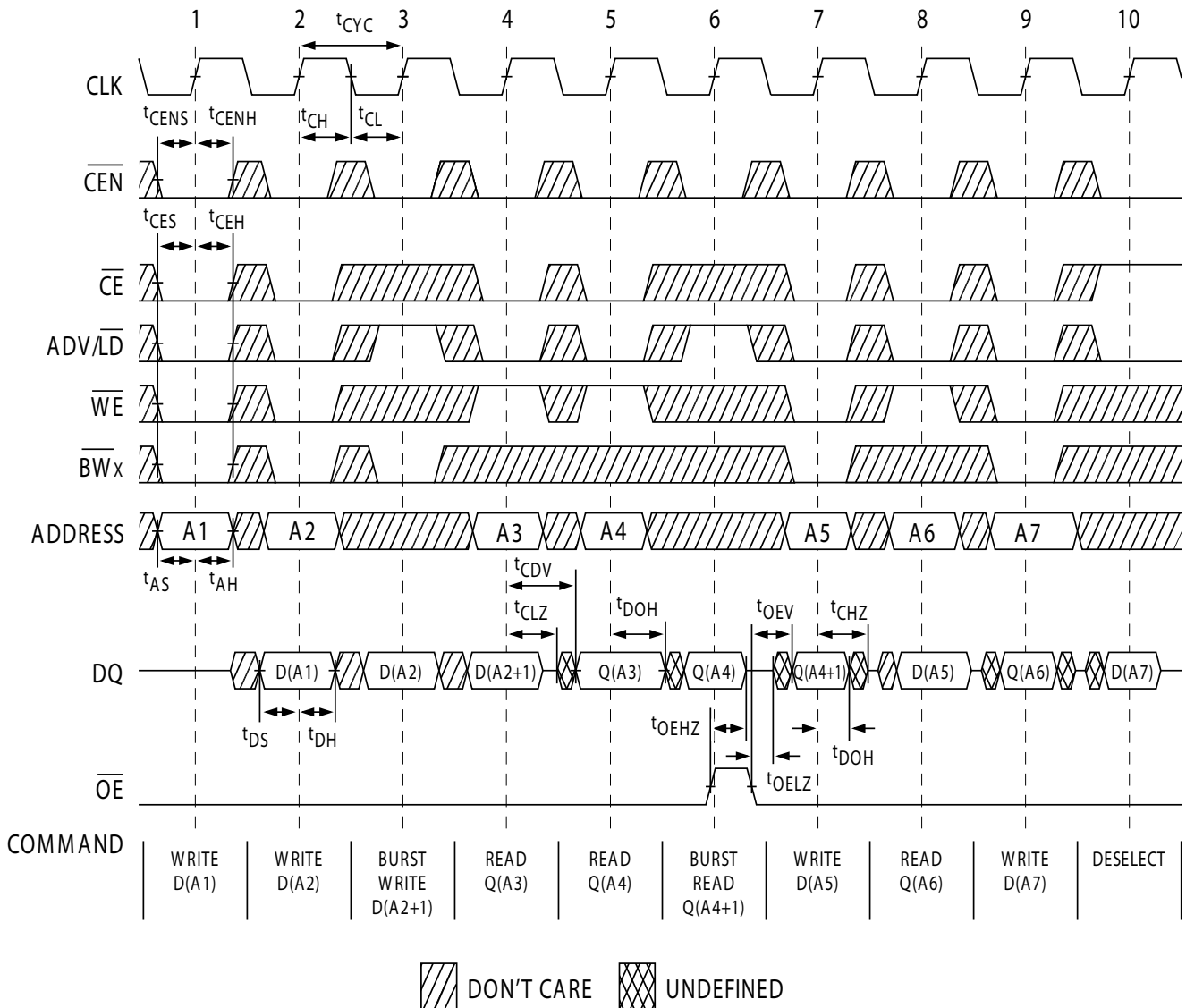

**Notes**

- 19. For this waveform ZZ is tied LOW.
- 20. When  $\overline{CE}$  is LOW,  $\overline{CE}_1$  is LOW,  $\overline{CE}_2$  is HIGH and  $\overline{CE}_3$  is LOW. When  $\overline{CE}$  is HIGH,  $\overline{CE}_1$  is HIGH or  $\overline{CE}_2$  is LOW or  $\overline{CE}_3$  is HIGH.
- 21. Order of the Burst sequence is determined by the status of the MODE (0 = Linear, 1 = Interleaved). Burst operations are optional.

Switching Waveforms (continued)

Figure 4. NOP, STALL and DESELECT Cycles [22, 23, 24]

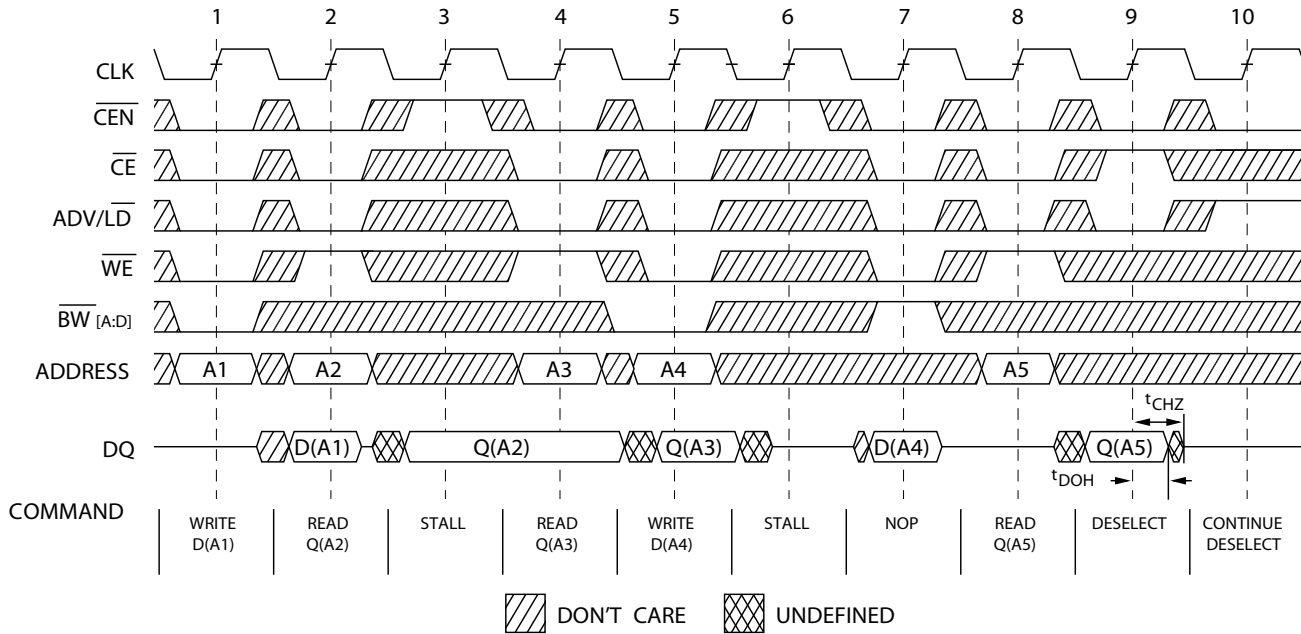

Notes

22. For this waveform  $\overline{ZZ}$  is tied LOW.

23. When  $\overline{CE}$  is LOW,  $\overline{CE}_1$  is LOW,  $CE_2$  is HIGH and  $\overline{CE}_3$  is LOW. When  $\overline{CE}$  is HIGH,  $\overline{CE}_1$  is HIGH or  $CE_2$  is LOW or  $\overline{CE}_3$  is HIGH.

24. The IGNORE CLOCK EDGE or STALL cycle (Clock 3) illustrates  $\overline{CEN}$  being used to create a pause. A write is not performed during this cycle.

Switching Waveforms (continued)

Figure 5. ZZ Mode Timing [25, 26]

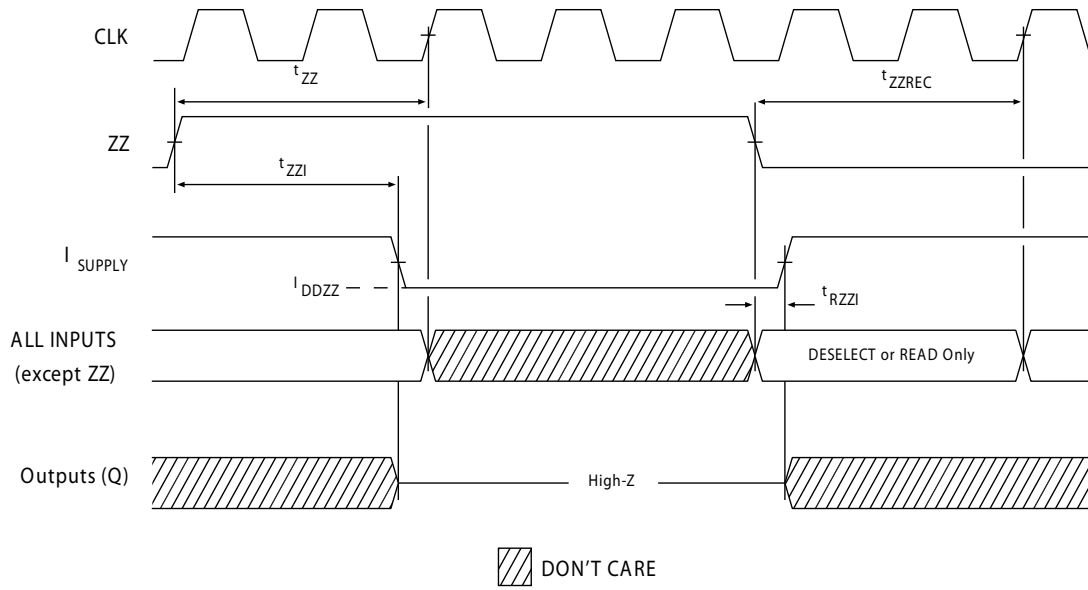

Notes

- 25. Device must be deselected when entering ZZ mode. See truth table for all possible signal conditions to deselect the device.
- 26. DQs are in High Z when exiting ZZ sleep mode.

## Ordering Information

Cypress offers other versions of this type of product in many different configurations and features. The following table contains only the list of parts that are currently available. For a complete listing of all options, visit the Cypress website at [www.cypress.com](http://www.cypress.com) and refer to the product summary page at <http://www.cypress.com/products> or contact your local sales representative. Cypress maintains a worldwide network of offices, solution centers, manufacturer's representatives and distributors. To find the office closest to you, visit us at <http://www.cypress.com/go/datasheet/offices>.

| Speed (MHz) | Ordering Code       | Package Diagram | Part and Package Type                   | Operating Range |
|-------------|---------------------|-----------------|---|-----------------|
| 133         | CY7C1463BV33-133AXI | 51-85050        | 100-pin TQFP (14 × 20 × 1.4 mm) Pb-free | Industrial      |

## Ordering Code Definitions

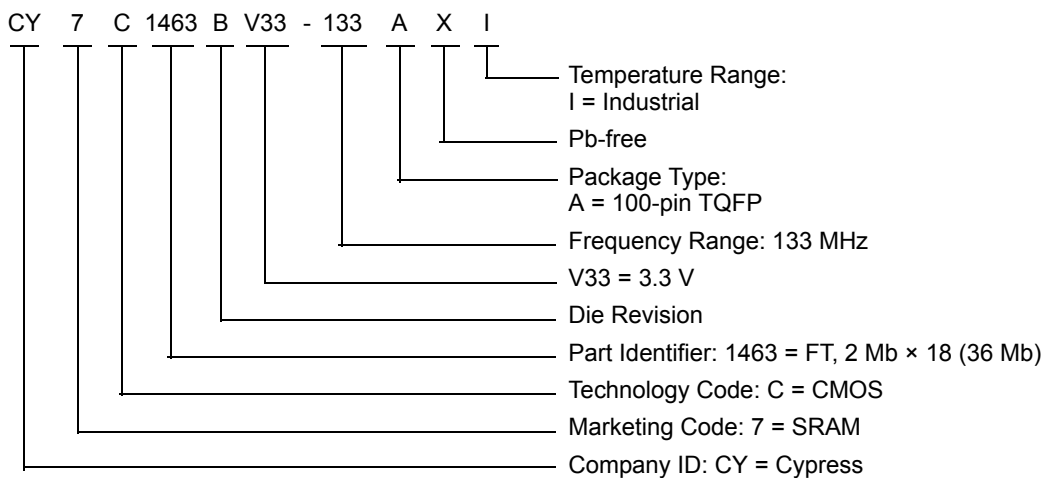

Package Diagram

Figure 6. 100-pin TQFP (14 × 20 × 1.4 mm) A100RA Package Outline, 51-85050

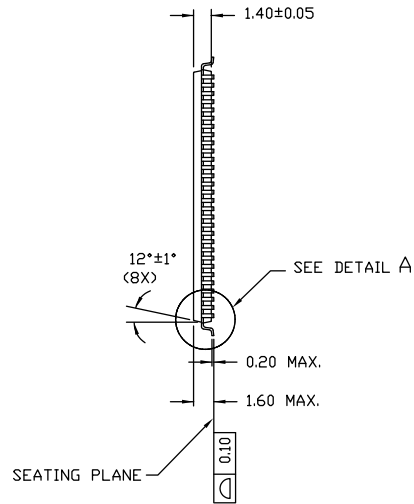
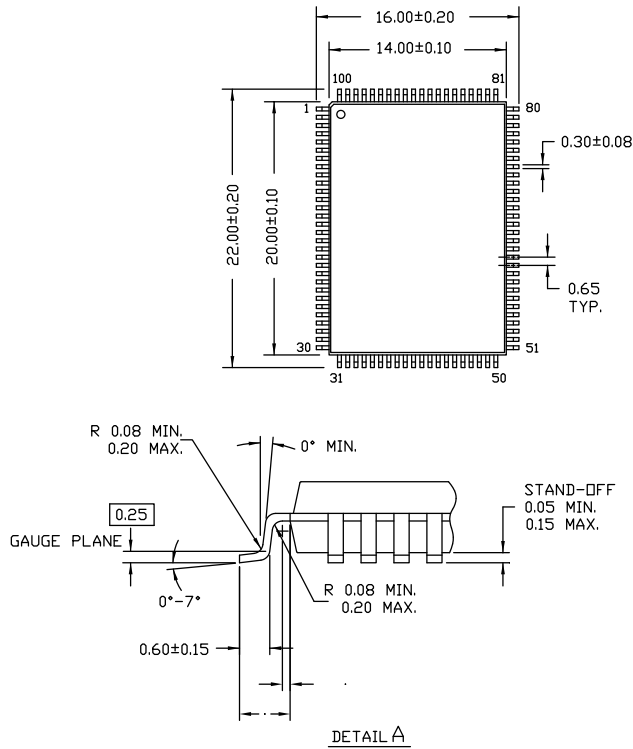

NOTE:

1. JEDEC STD REF MS-026
2. BODY LENGTH DIMENSION DOES NOT INCLUDE MOLD PROTRUSION/END FLASH  
MOLD PROTRUSION/END FLASH SHALL NOT EXCEED 0.0098 in (0.25 mm) PER SIDE  
BODY LENGTH DIMENSIONS ARE MAX PLASTIC BODY SIZE INCLUDING MOLD MISMATCH
3. DIMENSIONS IN MILLIMETERS

51-85050 \*E



### Acronyms

| Acronym          | Description                                |
|------------------|--|
| $\overline{CE}$  | Chip Enable                                |
| $\overline{CEN}$ | Clock Enable                               |
| CMOS             | Complementary Metal Oxide Semiconductor    |
| EIA              | Electronic Industries Alliance             |
| I/O              | Input/Output                               |
| JEDEC            | Joint Electron Devices Engineering Council |
| LMBU             | Logical Multiple Bit Upset                 |
| LSBU             | Logical Single Bit Upset                   |
| NoBL             | No Bus Latency                             |
| $\overline{OE}$  | Output Enable                              |
| SEL              | Single Event Latch-up                      |
| SRAM             | Static Random Access Memory                |
| TQFP             | Thin Quad Flat Pack                        |
| TTL              | Transistor-Transistor Logic                |
| $\overline{WE}$  | Write Enable                               |

### Document Conventions

#### Units of Measure

| Symbol | Unit of Measure |
|--------|-----------------|
| °C     | degree Celsius  |
| MHz    | megahertz       |
| μA     | microampere     |
| mA     | milliampere     |
| mm     | millimeter      |
| ms     | millisecond     |
| mV     | millivolt       |
| ns     | nanosecond      |
| Ω      | ohm             |
| %      | percent         |
| pF     | picofarad       |
| V      | volt            |
| W      | watt            |

## Document History Page

| Document Title: CY7C1463BV33, 36-Mbit (2 M × 18) Flow-Through SRAM with NoBL™ Architecture<br>Document Number: 001-75212 |         |            |                 |  |
|--|---------|------------|-----------------|--|
| Rev.   | ECN No. | Issue Date | Orig. of Change | Description of Change  |
| **   | 3488155 | 01/09/2012 | NJY             | New data sheet.  |
| *A   | 3534581 | 02/28/2012 | NJY             | Changed status from Preliminary to Final.  |
| *B   | 4575228 | 11/20/2014 | NJY             | Updated <a href="#">Functional Description</a> :<br>Added "For a complete list of related documentation, click <a href="#">here</a> ." at the end.<br>Updated <a href="#">Package Diagram</a> :<br>spec 51-85050 – Changed revision from *D to *E. |
| *C   | 5072986 | 01/05/2016 | PRIT            | Updated to new template.<br>Completing Sunset Review.  |

## Sales, Solutions, and Legal Information

### Worldwide Sales and Design Support

Cypress maintains a worldwide network of offices, solution centers, manufacturer's representatives, and distributors. To find the office closest to you, visit us at [Cypress Locations](#).

#### Products

|                          |  |
|--------------------------|--|
| Automotive               | <a href="http://cypress.com/go/automotive">cypress.com/go/automotive</a> |
| Clocks & Buffers         | <a href="http://cypress.com/go/clocks">cypress.com/go/clocks</a>         |
| Interface                | <a href="http://cypress.com/go/interface">cypress.com/go/interface</a>   |
| Lighting & Power Control | <a href="http://cypress.com/go/powerpsoc">cypress.com/go/powerpsoc</a>   |
| Memory                   | <a href="http://cypress.com/go/memory">cypress.com/go/memory</a>         |
| PSoC                     | <a href="http://cypress.com/go/psoc">cypress.com/go/psoc</a>             |
| Touch Sensing            | <a href="http://cypress.com/go/touch">cypress.com/go/touch</a>           |
| USB Controllers          | <a href="http://cypress.com/go/USB">cypress.com/go/USB</a>               |
| Wireless/RF              | <a href="http://cypress.com/go/wireless">cypress.com/go/wireless</a>     |

#### PSoC<sup>®</sup> Solutions

[psoc.cypress.com/solutions](http://psoc.cypress.com/solutions)  
PSoC 1 | PSoC 3 | PSoC 4 | PSoC 5LP

#### Cypress Developer Community

[Community](#) | [Forums](#) | [Blogs](#) | [Video](#) | [Training](#)

#### Technical Support

[cypress.com/go/support](http://cypress.com/go/support)

---

© Cypress Semiconductor Corporation, 2012-2016. The information contained herein is subject to change without notice. Cypress Semiconductor Corporation assumes no responsibility for the use of any circuitry other than circuitry embodied in a Cypress product. Nor does it convey or imply any license under patent or other rights. Cypress products are not warranted nor intended to be used for medical, life support, life saving, critical control or safety applications, unless pursuant to an express written agreement with Cypress. Furthermore, Cypress does not authorize its products for use as critical components in life-support systems where a malfunction or failure may reasonably be expected to result in significant injury to the user. The inclusion of Cypress products in life-support systems application implies that the manufacturer assumes all risk of such use and in doing so indemnifies Cypress against all charges.

Any Source Code (software and/or firmware) is owned by Cypress Semiconductor Corporation (Cypress) and is protected by and subject to worldwide patent protection (United States and foreign), United States copyright laws and international treaty provisions. Cypress hereby grants to licensee a personal, non-exclusive, non-transferable license to copy, use, modify, create derivative works of, and compile the Cypress Source Code and derivative works for the sole purpose of creating custom software and or firmware in support of licensee product to be used only in conjunction with a Cypress integrated circuit as specified in the applicable agreement. Any reproduction, modification, translation, compilation, or representation of this Source Code except as specified above is prohibited without the express written permission of Cypress.

Disclaimer: CYPRESS MAKES NO WARRANTY OF ANY KIND, EXPRESS OR IMPLIED, WITH REGARD TO THIS MATERIAL, INCLUDING, BUT NOT LIMITED TO, THE IMPLIED WARRANTIES OF MERCHANTABILITY AND FITNESS FOR A PARTICULAR PURPOSE. Cypress reserves the right to make changes without further notice to the materials described herein. Cypress does not assume any liability arising out of the application or use of any product or circuit described herein. Cypress does not authorize its products for use as critical components in life-support systems where a malfunction or failure may reasonably be expected to result in significant injury to the user. The inclusion of Cypress' product in a life-support systems application implies that the manufacturer assumes all risk of such use and in doing so indemnifies Cypress against all charges.

Use may be limited by and subject to the applicable Cypress software license agreement.

# Mouser Electronics

Authorized Distributor

Click to View Pricing, Inventory, Delivery & Lifecycle Information:

[Cypress Semiconductor:](#)

[CY7C1463BV33-133AXI](#)