



## IBIS5-B-1300 CYII5FM1300AB

# 1.3 MP CMOS Image Sensor

### Description

The IBIS5-B-1300 is a solid state CMOS image sensor that integrates the functionality of complete analog image acquisition, digitizer, and digital signal processing system on a single chip. This 1.3-mega pixel (1280 x 1024) CMOS active pixel sensor dedicated to industrial vision applications features both rolling and snapshot (or global) shutter. Full frame readout time is 36 ms (max. 27.5 fps), and readout speed are boosted by windowed region of interest (ROI) readout. Another feature includes the double and multiples slope functionality to capture high dynamic range scenes. The sensor is available in a Monochrome version or Bayer (RGB) patterned color filter array.

User programmable row and column start/stop positions allow windowing down to a 2x1 pixel window for digital zoom. Sub sampling or viewfinder mode reduces resolution while maintaining the constant field of view and an increased frame rate. An on-chip analog signal pipeline processes the analog video output of the pixel array. Double sampling (DS) eliminates the fixed pattern noise. The programmable gain and offset amplifier maps the signal swing to the ADC input range. A 10-bit ADC converts the analog data to a 10-bit digital word stream. The sensor uses a 2-wire, I<sup>2</sup>C™-compatible interface, a 3-wire serial parallel (SPI) interface, or a 16-bit parallel interface. It operates with a 3.3V power supply and requires only one master clock for operation up to 40 MHz. It is housed in an 84-pin ceramic LCC package.

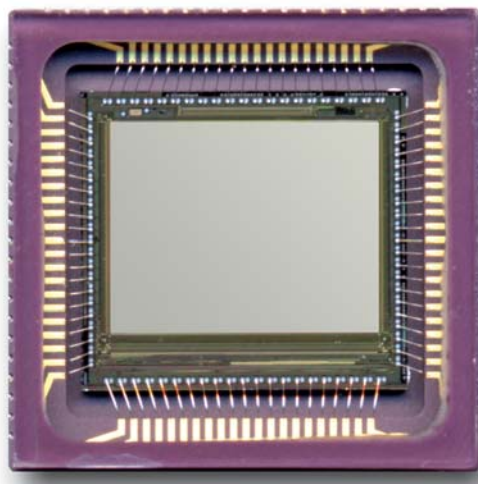
### Applications

- n Machine vision
- n Inspection
- n Robotics
- n Traffic monitoring

Table 1. Key Performance Parameters

| Parameter                        | Typical Value                                   |
|----------------------------------|---|
| Active pixels                    | 1280 (H) x 1024 (V)                             |
| Pixel size                       | 6.7 μm x 6.7 μm                                 |
| Optical format                   | 2/3 inch  |
| Shutter type                     | Snapshot (global) shutter<br>rolling shutter    |
| Maximum data rate / master clock | 40 MPS / 40 MHz                                 |
| Frame rate                       | 27 fps (1280 x 1024)<br>106 fps (640 x 480)     |
| ADC resolution                   | 10-bit, on-chip                                 |
| Sensitivity (@ 650 nm)           | 715 V.m <sup>2</sup> /W.s<br>8.40 V/lux.s       |
| S/N ratio                        | 64 dB   |
| Full well charge                 | 62.500 e <sup>-</sup>                           |
| Temporal noise                   | 40 e <sup>-</sup>                               |
| Dark current                     | 7.22 mV/s                                       |
| High dynamic range               | Multiple slope                                  |
| Supply voltage                   | Analog: 3.0V–4.5V<br>Digital: 3.3V<br>I/O: 3.3V |
| Power consumption                | 175 mW  |
| Operating temperature            | –30°C to +65°C                                  |
| Color filter array               | Mono<br>RGB Bayer pattern                       |
| Packaging                        | 84-pins LCC                                     |

### IBIS5-B-1300



## Architecture and Operation

This section presents detailed information about the most important sensor blocks.

### Floor Plan

Figure 1. Block Diagram of the IBIS5-B-1300 Image Sensor

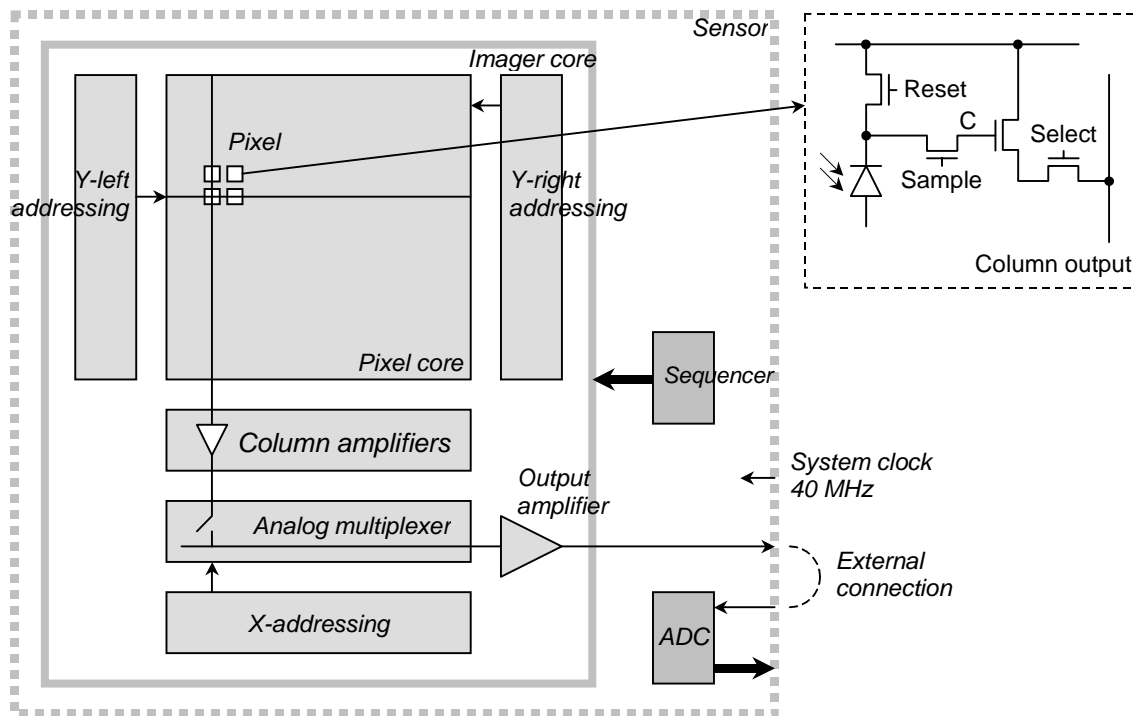


Figure 1 shows the architecture of the IBIS5-B-1300 image sensor. It consists basically of a pixel array, one X- and two Y-addressing registers for the readout in X- and Y-direction, column amplifiers that correct for the fixed pattern noise, an analog multiplexer, and an analog output amplifier.

Use the left Y-addressing register for readout operation. Use the right Y-addressing register for reset of pixel rows. In multiple slope synchronous shutter mode, the right Y-addressing register resets the whole pixel core with a lowered reset voltage. In rolling curtain shutter mode, use the right Y-addressing register for the reset pointer in single and double slope operation to reset one pixel row.

The on-chip sequencer generates most of the signals for the image core. Some basic signals (like start/stop integration, line and frame sync signals, and others.) are generated externally.

A 10-bit ADC is implemented on chip but electrically isolated from the image core. You must route the analog pixel output to the analog ADC input on the outside.

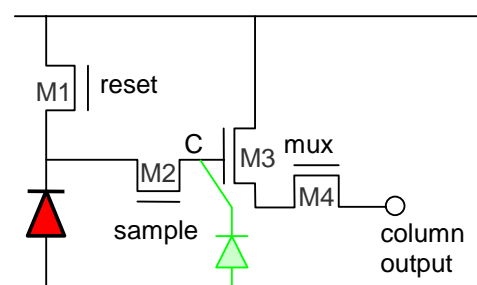
### Pixel

A description of the pixel architecture and the color filter array follows.

### Architecture

The pixel architecture used in the IBIS5-B-1300 is a 4-transistor pixel as shown in Figure 2. Implement the pixel using the high fill factor technique as patented by Cypress (US patent No. 6,225,670 and others). The 4T-pixel features a snapshot shutter but can also emulate the 3T-pixel by continuously closing sampling switch M2. Using M4 as a global sample transistor for all pixels enables the snapshot shutter mode. Due to this pixel architecture, integration during read out is not possible in synchronous shutter mode.

Figure 2. Architecture of the 4T-pixel



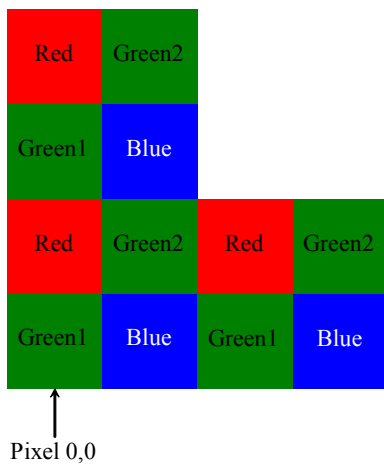


# IBIS5-B-1300 CYII5FM1300AB

### Color Filter Array

The IBIS5-B-1300 is also processed with a Bayer RGB color pattern. Pixel (0,0) has a green filter and is situated on a green-blue row. Green1 and green2 have a slightly different spectral response due to cross talk from neighboring pixels. Green1 pixels are located on a blue-green row, green2 pixels are located on a green-red row. Figure 4 shows the response of the color filter array as function of the wavelength. Note that this response curve includes the optical cross talk of the pixels.

Figure 3. Color Filter Arrangement on the Pixels



### Frame Rate

The pixel rate for this sensor is high enough to support a frame rate of >100 Hz for a window size of 640 x 480 pixels (VGA format). Taking into account a row blanking time of 3.5 μs (as baseline, see also "Internal clock granularities (bits 4, 5, 6 and

7)." on page 13), this requires a minimum pixel rate of nearly 40 MHz. The final bandwidth of the column amplifiers, output stage, and others is determined by external bias resistors. With a nominal pixel rate of 40 MHz, a full frame rate of a little more than 27 frames per second is obtained.

The frame period of the IBIS5-B-1300 sensor depends on the shutter type.

### Rolling Shutter

=> Frame period = (Nr. Lines \* (RBT + pixel period \* Nr. Pixels))

with:

- Nr. Lines Number of lines read out each frame (Y)
- Nr. Pixels Number of pixels read out each line (X)
- RBT Row blanking time = 3.5 μs (typical)
- Pixel period 1/40 MHz = 25 ns

**Example** Read out time of the full resolution at nominal speed (40-MHz pixel rate):

=> Frame period = (1024 \* (3.5 μs + 25 ns \* 1280)) = 36.4 ms  
=> 27.5 fps

### Snapshot shutter

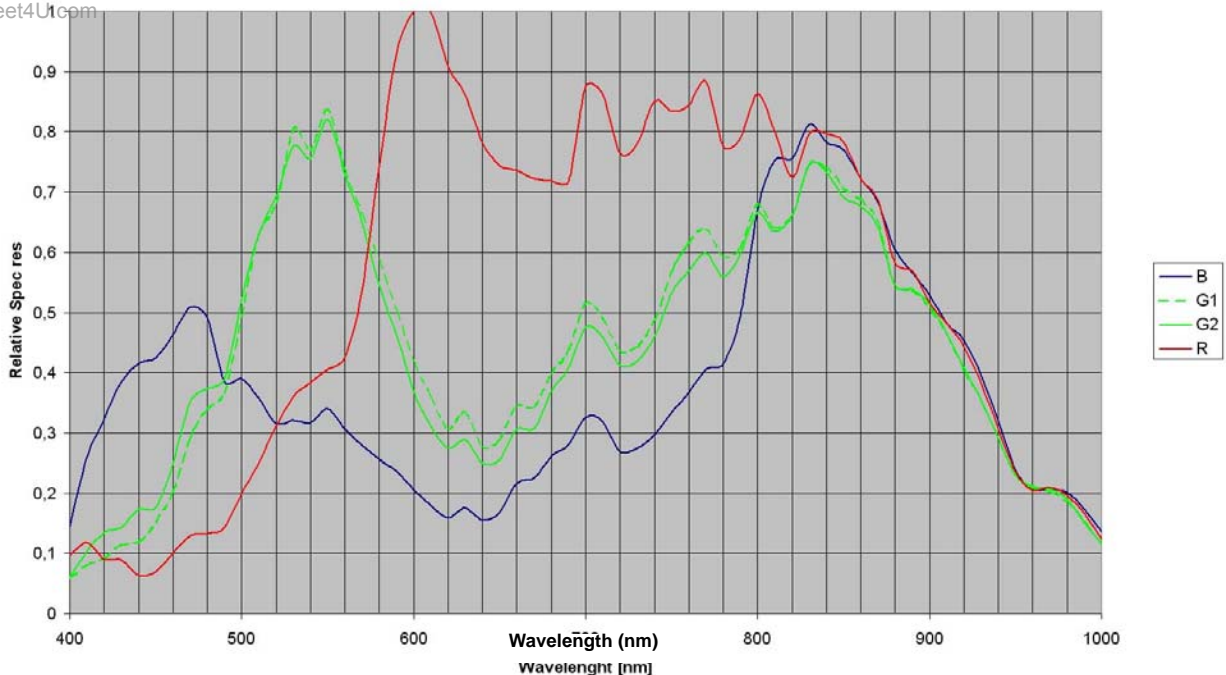
=> Frame period = Tint + Tread out

= Tint + (Nr. Lines \* (RBT + pixel period \* Nr. Pixels))

with:

- Tint Integration (exposure) time
- Nr. Lines Number of lines read out each frame (Y)
- Nr. Pixels Number of pixels read out each line (X)
- RBT Row blanking time = 3.5 μs (typical)
- Pixel period 1/40 MHz = 25 ns

Figure 4. Color Filter Response





## IBIS5-B-1300 CYII5FM1300AB

**Example** Read out time of the full resolution at nominal speed (40 MHz pixel rate) with an integration time of 1 ms:

=> Frame period = 1 ms + (1024 \* (3.5 μs + 25 ns \* 1280)) = 37.4 ms => 26.8 fps

### Region-Of-Interest (ROI) Read Out

Windowing is easily achieved by uploading the starting point of the X- and Y-shift registers in the sensor registers using the various interfaces. This downloaded starting point initiates the shift register in the X- and Y-direction triggered by the Y\_START (initiates the Y-shift register) and the Y\_CLK (initiates the X-shift register) pulse. The minimum step size for the x-address is two (only even start addresses are chosen) and one for the Y-address (every line is addressable). The frame rate increases almost linearly when fewer pixels are read out. Table 2 gives an overview of the achievable frame rates (in rolling shutter mode) with various ROI dimensions.

**Table 2. Frame Rate vs. Resolution**

| Image Resolution (X*Y) | Frame Rate [frames/s] | Frame Readout Time [ms] | Comment          |
|------------------------|-----------------------|-------------------------|------------------|
| 1280 x 1024            | 27                    | 36                      | Full resolution. |
| 640 x 480              | 100                   | 10                      | ROI read out.    |
| 100 x 100              | 1657                  | 0.6                     | ROI read out.    |

## Image Core Operation

### Image Core Operation and Signalling

Figure 5 is a functional representation of the image core without sub-sampling and column/row swapping circuits. Most of the signals involved are not available from the outside because they are generated by the X-sequencer and SS-sequencer blocks.

The integration of the pixels is controlled by internal signals such as reset, sample, and hold which are generated by the on-chip SS-sequencer that is controlled with the external signals SS\_START and SS\_STOP. Reading out the pixel array starts by applying a Y\_START together with a Y\_CLOCK signal; internally this is followed by a calibration sequence to calibrate the output amplifiers (during the row blanking time). Signals necessary to do this calibration are generated by the on-chip X-sequencer. This calibration sequence takes typically 3.5 μs and is necessary to remove 'Fixed Pattern Noise' of the pixels and of the column amplifiers themselves by means of a double sampling technique. After the row blanking time, the pixels are fed to the output amplifier. The pixel rate is equal to the SYS\_CLOCK frequency.

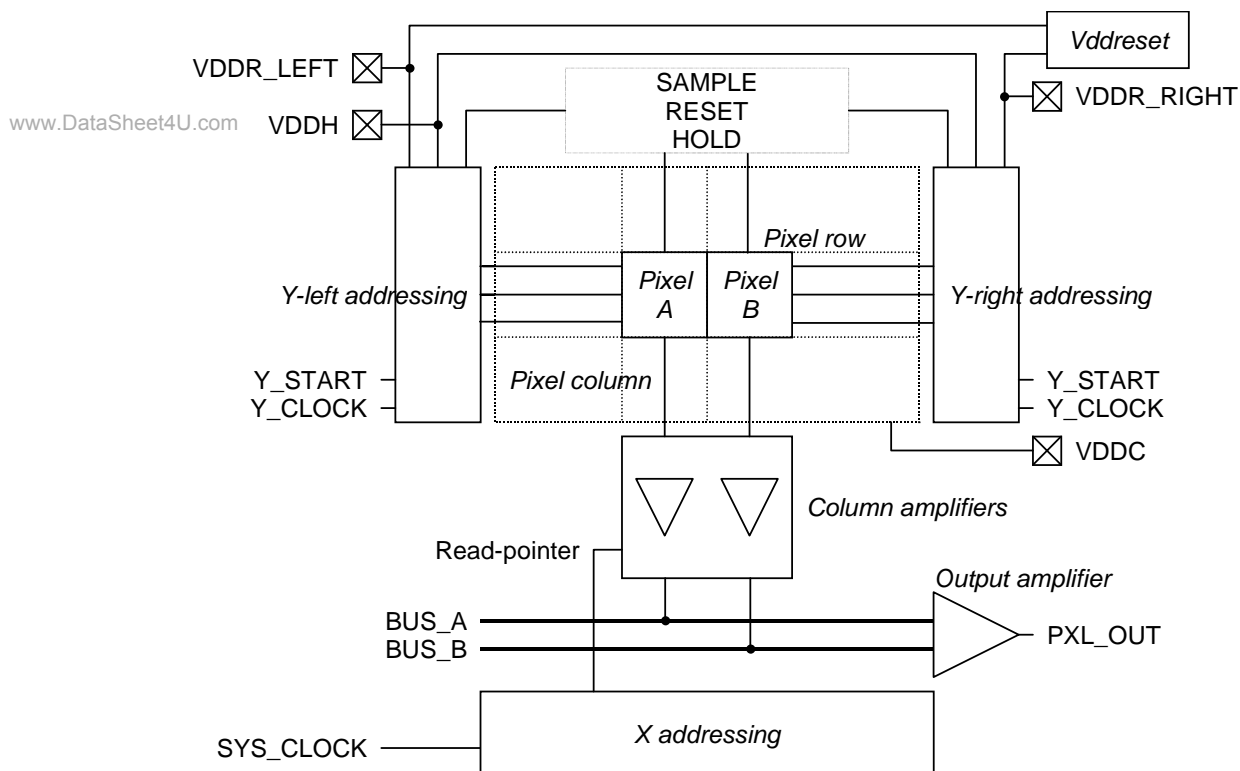
### Image Core Supply Considerations

The image sensor has several supply voltages:

VDDH is the voltage that controls the sample switches. Do not apply a higher voltage than this to the chip.

The VDDR\_LEFT voltage is the highest (nominal) reset voltage of the pixel core.

**Figure 5. Image Core**





## IBIS5-B-1300 CYII5FM1300AB

The VDDR\_RIGHT voltage is generated from the VDDR\_LEFT voltage using a circuit that is programmed with the KNEEPOINT\_LSB/MSB bits in the sequencer register (see also "Pixel reset knee-point for multiple slope operation (bits 8, 9, and 10)." on page 14). You can disconnect the VDDR\_RIGHT pin from the circuit and apply an external voltage to supply the multiple slope reset voltage by setting the VDDR\_RIGHT\_EXT bit in the SEQUENCER register. When no external voltage is applied (recommended), connect the VDDR\_RIGHT pin to a capacitor (recommended value = 1 $\mu$ F). VDDC is the pixel core supply. VDDA is the image core and periphery analog supply. VDDD is the image core and periphery digital supply.

Note that the IBIS5-B-1300 image sensor has no on-chip power rejection circuitry. As a consequence all variations on the analog supply voltages can contribute to random variations (noise) on the analog pixel signal, which is seen as random noise in the image. During the camera design, take precautions to supply the sensor with very stable supply voltages to avoid this additional noise. The pixel array (VDDR\_LEFT, VDDH and VDDC) analog supplies are especially vulnerable to this.

### Snapshot Shutter Supply Considerations

The recommended supply voltage settings listed in Table 3 are used when the IBIS5-B-1300 sensor is in snapshot shutter mode only.

**Table 3. Snapshot Shutter Recommended Supply Settings**

| Parameter | Description                               | Typ  | Unit |
|-----------|---|------|------|
| VDDH      | Voltage on HOLD switches.                 | +4.5 | V    |
| VDDR_LEFT | Highest reset voltage.                    | +4.5 | V    |
| VDDC      | Pixel core voltage.                       | +3.3 | V    |
| VDDA      | Analog supply voltage of the image core.  | +3.3 | V    |
| VDDD      | Digital supply voltage of the image core. | +3.3 | V    |
| GNDA      | Analog ground.                            | 0    | V    |
| GNDD      | Digital ground.                           | 0    | V    |
| GND_AB    | Anti-blooming ground.                     | 0    | V    |

### Dual Shutter Supply Considerations

If you analyze the supply settings listed in Table 3, you can see some fixed column non-uniformities (FPN) when operating in rolling shutter mode. If a dual shutter mode (both rolling and snapshot shutter) is required during operation, you must apply the supply settings listed in Table 4 to achieve the best possible image quality.

**Table 4. Dual Shutter Recommended Supply Settings**

| Parameter | Description                               | Typ  | Unit |
|-----------|---|------|------|
| VDDH      | Voltage on HOLD switches.                 | +4.5 | V    |
| VDDR_LEFT | Highest reset voltage.                    | +4.5 | V    |
| VDDC      | Pixel core voltage.                       | +3.0 | V    |
| VDDA      | Analog supply voltage of the image core.  | +3.3 | V    |
| VDDD      | Digital supply voltage of the image core. | +3.3 | V    |
| GNDA      | Analog ground.                            | 0    | V    |
| GNDD      | Digital ground.                           | 0    | V    |
| GND_AB    | Anti-blooming ground.                     | 0    | V    |

### Image Core Biasing Signals

Table 5 summarizes the biasing signals required to drive the IBIS5-A-1300. For optimizations reasons, with respect to speed and power dissipation of all internal blocks, several biasing resistors are needed.

Each biasing signal determines the operation of a corresponding module in the sense that it controls the speed and power dissipation. The tolerance on the DC-level of the bias levels can vary  $\pm 150$  mV due to process variations.

**Table 5. Overview of Bias Signals**

| Signal    | Comment  | Related module               | DC-Level |
|-----------|--|------------------------------|----------|
| DEC_CMD   | Connect to VDDA with R = 50 k $\Omega$ and decouple to GNDA with C = 100 nF. | Decoder stage.               | 1.0V     |
| DAC_VHIGH | Connect to VDDA with R = 0 $\Omega$ .  | High level of DAC.           | 3.3V     |
| DAC_VLOW  | Connect to GNDA with R = 0 $\Omega$ .  | Low level of DAC.            | 0.0V     |
| AMP_CMD   | Connect to VDDA with R = 50 k $\Omega$ and decouple to GNDA with C = 100 nF. | Output amplifier stage.      | 1.2V     |
| COL_CMD   | Connect to VDDA with R = 50 k $\Omega$ and decouple to GNDA with C = 100 nF. | Columns amplifiers stage.    | 1.0V     |
| PC_CMD    | Connect to VDDA with R = 25 k $\Omega$ and decouple to GNDA with C = 100 nF. | Pre-charge of column busses. | 1.1V     |
| ADC_CMD   | Connect to VDDA with R = 50 k $\Omega$ and decouple to GNDA with C = 100 nF. | Analog stage of ADC.         | 1.0V     |
| ADC_VHIGH | Connect to VDDA with R = 360 $\Omega$ and decouple to GNDA with C = 100 nF.  | High level of ADC.           | 2.7V     |
| ADC_VLOW  | Connect to GNDA with R = 1200 $\Omega$ and decouple to GNDA with C = 100 nF. | Low level of ADC.            | 1.8V     |



## IBIS5-B-1300 CYII5FM1300AB

### X-Addressing

Because of the high pixel rate, the X-shift register selects two columns at a time for readout, so it runs at half the system clock speed. All even columns are connected to bus A; all odd columns to bus B. In the output amplifier, bus A and bus B are combined into one stream of pixel data at system clock speed.

At the end of the row blanking time, the X\_SYNC switch is closed while all other switches are open and the decoder output is fed to the register. The decoder loads a logical one in one of the registers and a logical zero in the rest. This defines the starting point of the window in the X direction. As soon as the X\_SYNC signal is released, the register starts shifting from the start position.

When no sub-sampling is required, X\_SUB is inactive. The pointer in the shift-register moves one bit at a time.

When sub-sampling is enabled, X\_SUB is activated. The shift register moves two bits at a time. Taking into account that every register selects two columns, hence two pixels sub-sampling results in the pattern 'XXOOXXOO' when eight pixels are considered. Suppose the columns are numbered from left to right starting with 0 (zero) and sub-sampling is enabled:

If columns 1 and 2, 5 and 6, 9 and 10 ... are swapped using the SWAP\_12 switches, a normal sub-sampling pattern of 'XOXOXOXO' is obtained.

If columns 3 and 4, 7 and 8, 11 and 12 ... are swapped using the SWAP\_30 switches, the pattern is 'OXOXOXOX'.

If both the SWAP\_12 and SWAP\_30 switches are closed, pattern 'OOXXOOXX' is obtained.

Because every register addresses two columns at a time, the addressable pixels range in sub-sample mode is from zero to half the maximum number of pixels in a row (only even values). For instance: 0, 2, 4, 6, 8... 638.

**Table 6. X-Sub-sample Patterns**

| X_SUB | X_SWAP12 | X_SWAP30 | Sub-Sample Pattern |
|-------|----------|----------|--------------------|
| 0     | 0        | 0        | XXXXXXXX           |
| 1     | 0        | 0        | XXOOXXOO           |
| 1     | 1        | 0        | XOXOXOXO           |
| 1     | 0        | 1        | OXOXOXOX           |
| 1     | 1        | 1        | OOXXOOXX           |

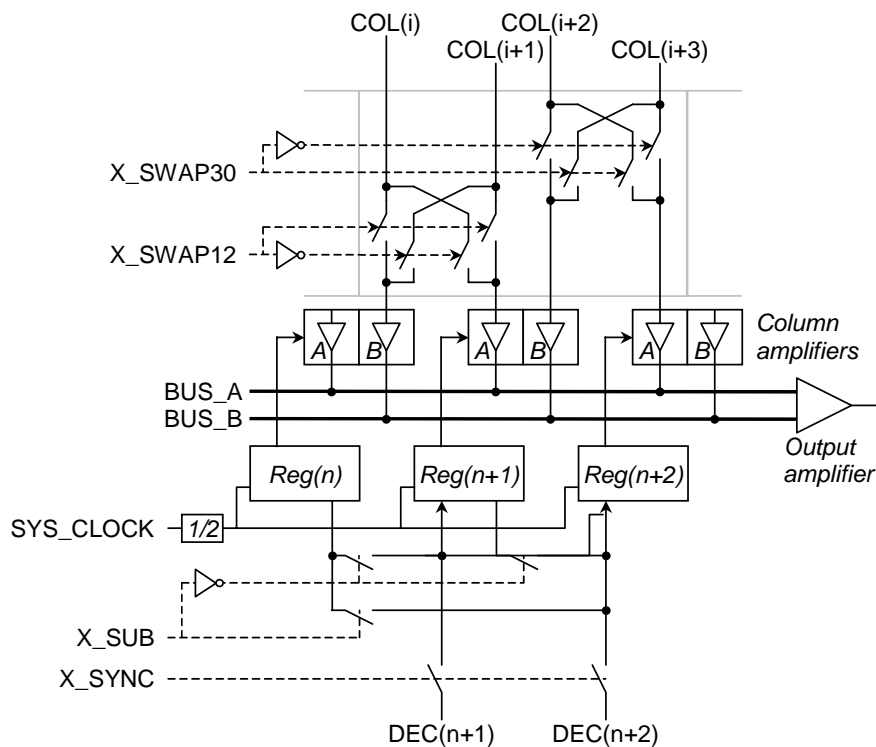
### Y-addressing

For symmetry reasons, the sub-sampling modes in the Y-direction are the same as in X-direction.

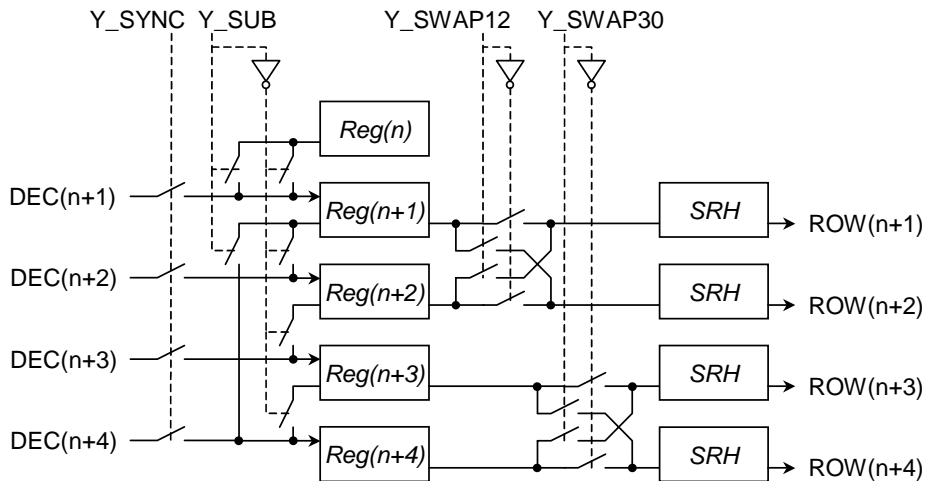
**Table 7. Y-Sub-Sample Patterns**

| Y_SUB | Y_SWAP12 | Y_SWAP30 | Sub-Sample Pattern |
|-------|----------|----------|--------------------|
| 0     | 0        | 0        | XXXXXXXX           |
| 1     | 0        | 0        | XXOOXXOO           |
| 1     | 1        | 0        | XOXOXOXO           |
| 1     | 0        | 1        | OXOXOXOX           |
| 1     | 1        | 1        | OOXXOOXX           |

**Figure 6. Column Structure**



www.DataSheet4U.com

**Figure 7. Row Structure**

In normal mode, the pointer for the pixel row is shifted one at a time.

When sub-sampling is enabled, Y\_SYNC is activated. The Y-shift register shifts 2 succeeding bits and skips the 2 next bits. This results in pattern 'XXOOXXOO'.

Activating Y\_SWAP12 results in pattern 'XOXOXOXO'.

Activating Y\_SWAP30 results in pattern 'OXOXOXOX'.

Activating both Y\_SWAP12 and Y\_SWAP30 results in pattern 'OOXXOOXX'.

The addressable pixel range when Y-sub sampling is enabled is: 0-1, 4-5, 8-9, 12-13, ... 1020-1021

## Output Amplifier

### Architecture and Settings

The output amplifier stage is user programmable for gain and offset level. Gain is controlled by 4-bit wide word; offset by a 7-bit wide word. Gain settings are on an exponential scale. Offset is controlled by a 7-bit wide DAC, which selects the offset voltage between two reference voltages (DAC\_VHIGH and DAC\_VLOW) on a linear scale.

The amplifier is designed to match the specifications of the imager array output. This signal has a data rate of 40 MHz and is located between 1.17V and 2.95V. The output impedance of the amplifier is 260Ω.

The output signal has a range between 1.17V and 2.95V, depending on the gain and offset settings of the amplifier. At unity gain and with a mid-range offset value, the amplifier outputs a signal in between 1.59V (light) and 2.70V (dark). This analog range must fit to the input range of the ADC, external or internal. The output swing in unity gain is approximately 1.11V and maximum 1.78V at the highest gain settings.

Figure 8 on page 8 shows the architecture of the output amplifier. The odd and even column amplifiers sample both pixel and reset value to perform a double sampling FPN correction. You can adjust two different offsets using the on-chip DAC (7 bit): DAC\_FINE and DAC\_RAW. DAC\_FINE is used to tune the difference between odd and even columns; DAC\_RAW is used to add a general (both even and odd columns) to the FPN

corrected pixel value. This pixel value is fed to the first amplifier stage which has an adjustable gain, controlled by a 4-bit word ('GAIN [0...3]').

After this, a unity feedback amplifier buffers the signal and the signal leaves the chip. This second amplifier stage determines the maximal readout speed, that is, the bandwidth and the slew rate of the output signal. The whole amplifier chain is designed for a data rate of 40 Mpix/s (@20 pF).

### Output Amplifier Gain Control

The output amplifier gain is controlled by a 4-bit word set in the AMPLIFIER register (see section "Amplifier Register (6:0)" on page 15). An overview of the gain settings is given in Table 8.

**Table 8. Overview Gain Settings**

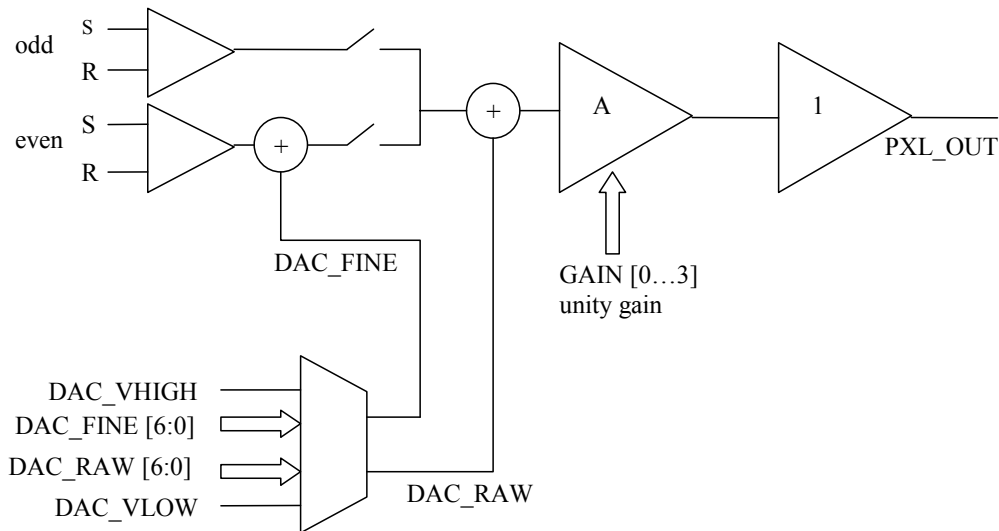
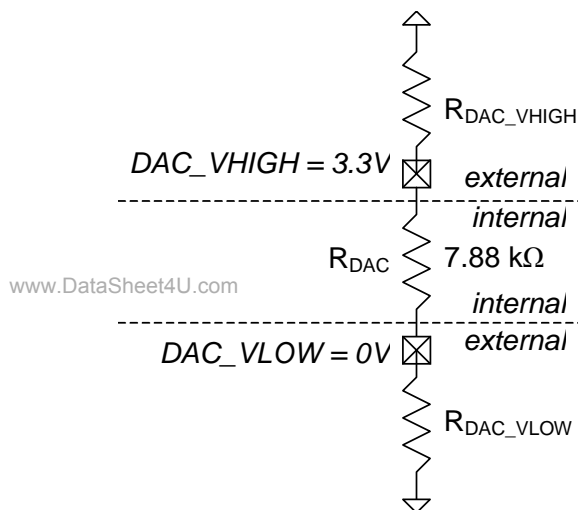
| Bits | DC Gain | Bits | DC Gain |
|------|---------|------|---------|
| 0000 | 1.37    | 1000 | 6.25    |
| 0001 | 1.62    | 1001 | 7.89    |
| 0010 | 1.96    | 1010 | 9.21    |
| 0011 | 2.33    | 1011 | 11.00   |
| 0100 | 2.76    | 1100 | 11.37   |
| 0101 | 3.50    | 1101 | 11.84   |
| 0110 | 4.25    | 1110 | 12.32   |
| 0111 | 5.20    | 1111 | 12.42   |

### Setting of the DAC Reference Voltage

In the output amplifier, the offset is trimmed by loading registers DACRAW\_REG and DACFINE\_REG. DAC\_RAW is used to adjust the offset of the output amplifier and DAC\_FINE is used to tune the offset between the even and odd columns. These registers are inputs for two DACs (see Figure 9 on page 8) that operate on the same resistor that is connected between pins DAC\_VHIGH and DAC\_VLOW. The range of the DAC is defined using a resistive division with  $R_{VHIGH}$ ,  $R_{DAC}$  and  $R_{VLOW}$ .

The internal resistor  $R_{DAC}$  has a value of approximately 7.88 kΩ.

The recommend resistor values for both DAC\_VLOW and DAC\_VHIGH are 0Ω.

**Figure 8. Output Structure****Figure 9. In- and External DAC Connections****Analog to Digital Converter**

The IBIS5-B-1300 has a 10-bit flash analog digital converter running nominally at 40 Msamples/s. The ADC is electrically separated from the image sensor. Tie the input of the ADC (ADC\_IN; pin 69) externally to the output (PXL\_OUT1; pin 28) of the output amplifier.

**Table 9. ADC Specifications**

|                              |                            |
|------------------------------|----------------------------|
| Input range                  | 1–3V <sup>[1]</sup>        |
| Quantization                 | 10 Bits                    |
| Nominal data rate            | 40 Msamples/s              |
| DNL (linear conversion mode) | Typ. < 0.5 LSB             |
| INL (linear conversion mode) | Typ. < 3 LSB               |
| Input capacitance            | < 20 pF                    |
| Power dissipation @ 40 MHz   | Typ. 45 mA * 3.3V = 150 mW |
| Conversion law               | Linear / Gamma-corrected   |

**ADC Timing**

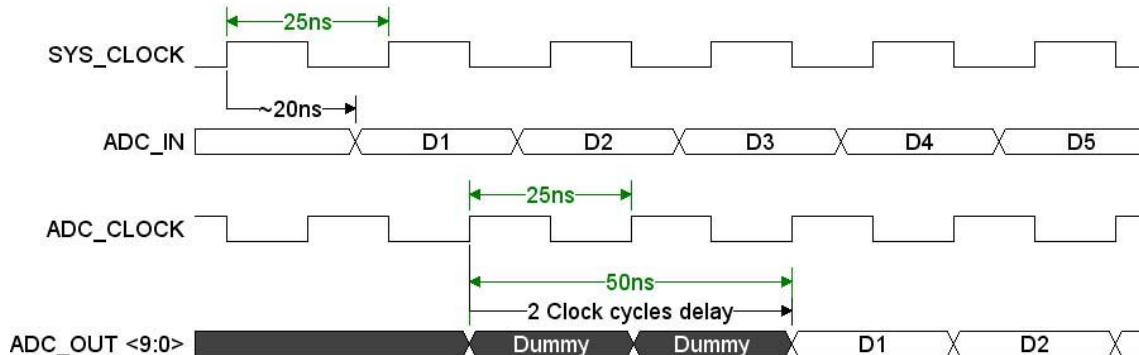
At the rising edge of SYS\_CLOCK, the next pixel is fed to the input of the output amplifier. Due to internal delays of the SYS\_CLOCK signal, it takes approximately 20 ns before the output amplifier outputs the analog value of the pixel as shown in Figure 10 on page 9.

The ADC converts the pixel data on the rising edge of the ADC\_CLOCK, but it takes two clock cycles before this pixel data is at the output of the ADC. Figure 10 shows this pipeline delay.

**Note**

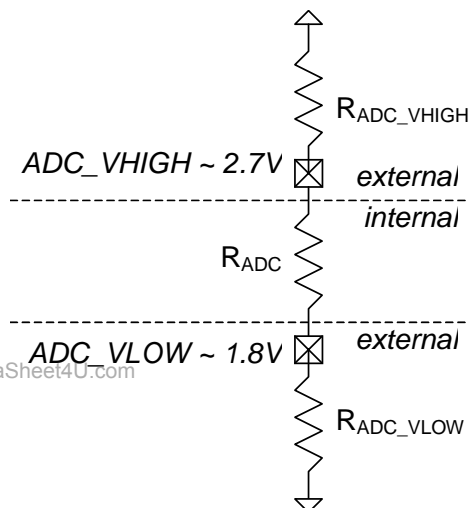
1. The internal ADC range is typically 100 mV lower than the external applied ADC\_VHIGH and ADC\_VLOW voltages due to voltage drops over parasitic internal resistors



**Figure 10. ADC Timing**

Due to these delays, it is advisable that a variable phase difference is foreseen between the ADC\_CLOCK and the SYS\_CLOCK to tune the optimal sample moment of the ADC.

#### Setting of the ADC Reference Voltages

**Figure 11. In- and External ADC Connections**

The internal resistor  $R_{ADC}$  has a value of approximately  $585\Omega$ . This results in the following values for the external resistors:

| Resistor         | Value (Ω) |
|------------------|-----------|
| $R_{ADC\_VHIGH}$ | 360       |
| $R_{ADC}$        | 585       |
| $R_{ADC\_VLOW}$  | 1200      |

Note that the recommended ADC resistor values yield in a conversion of the full analog output swing at unity gain ( $V_{DARK\_ANALOG} < ADC\_VHIGH$  and  $V_{LIGHT\_ANALOG} > ADC\_VLOW$ ).

The values of the resistors depend on the value of  $R_{ADC}$ . To assure proper working of the ADC, make certain the voltage difference between  $ADC\_VLOW$  and  $ADC\_VHIGH$  is at least 1.0V.

#### Non-linear and Linear Conversion Mode—'gamma' Correction

Figure 12 on page 10 shows the ADC transfer characteristic. The non-linear (exponential) ADC conversion is intended for gamma-correction of the images. It increases contrast in dark areas and reduces contrast in bright areas. The non-linear transfer function is given by:

$$V_{in} = ADC\_VHIGH + (ADC\_VHIGH - ADC\_VLOW) * \frac{a*x + b*x^2}{a*1023 + b*1023^2}$$

With:

$$a = 5$$

$$b = 0.027$$

$x$  = digital output code

#### Electronic Shutter Types

The IBIS5-B-1300 has two different shutter types: a rolling (curtain) shutter and a snapshot (synchronous) shutter.

##### Rolling (Curtain) Shutter

The name is due to the fact that the effect is similar to a curtain shutter of a SLR film camera. Although it is a pure electronic operation, the shutter seems to slide over the image. A rolling shutter is easy and elegant to implement in a CMOS sensor. Notice that in Figure 13 on page 10, there are two Y-shift registers. One of them points to the row that is currently being read out. The other shift register points to the row that is currently being reset. Both pointers are shifted by the same Y-clock and move over the focal plane. The integration time is set by the delay between both pointers.

Figure 13 on page 10 graphically displays the relative shift of the integration times for different lines during the rolling shutter operation. Each line is read and reset in a sequential way. The integration time is the same for all lines, but is shifted in time. You can vary the integration time through the INT\_TIME register (in number of lines).

This indicates that all pixels are light sensitive at another period of time, and can cause some blurring if a fast moving object is captured.

When the sensor is set to rolling shutter mode, make certain to hold the input SS\_START and SS\_STOP low.



# IBIS5-B-1300 CYII5FM1300AB

Figure 12. Linear and Non-linear ADC Conversion Characteristic

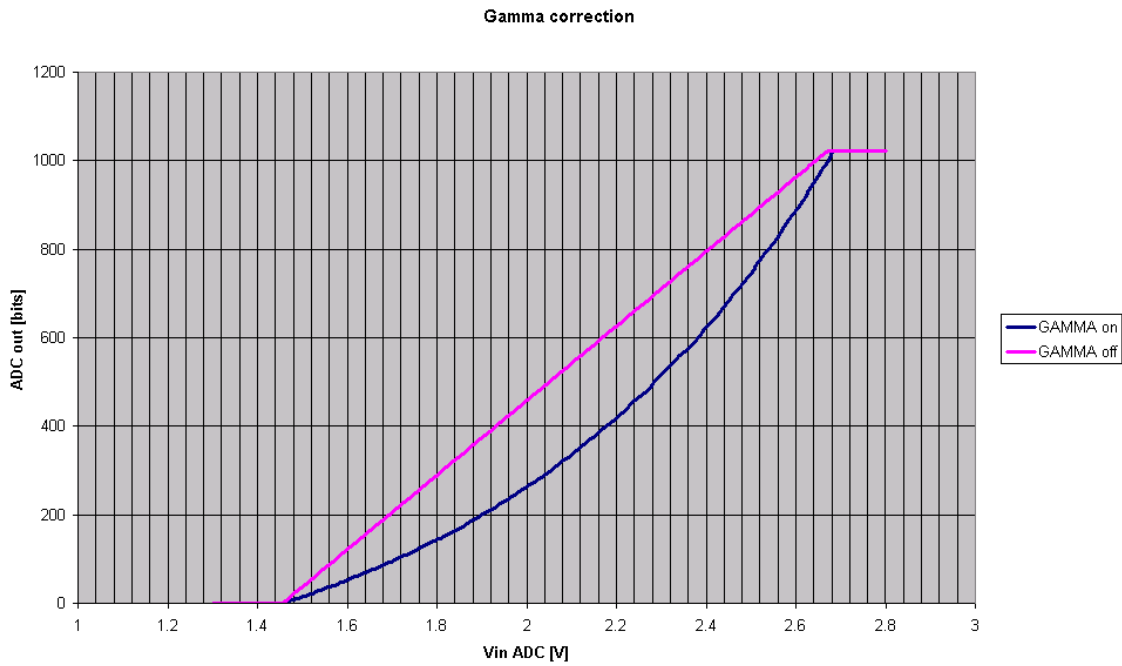
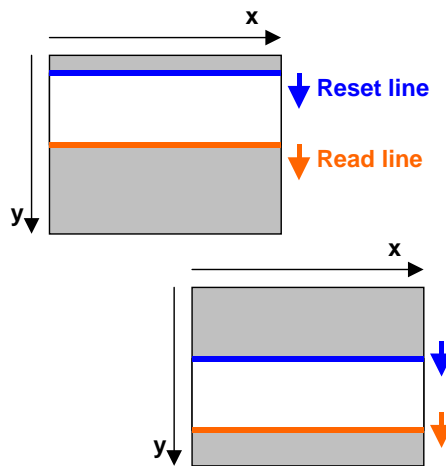
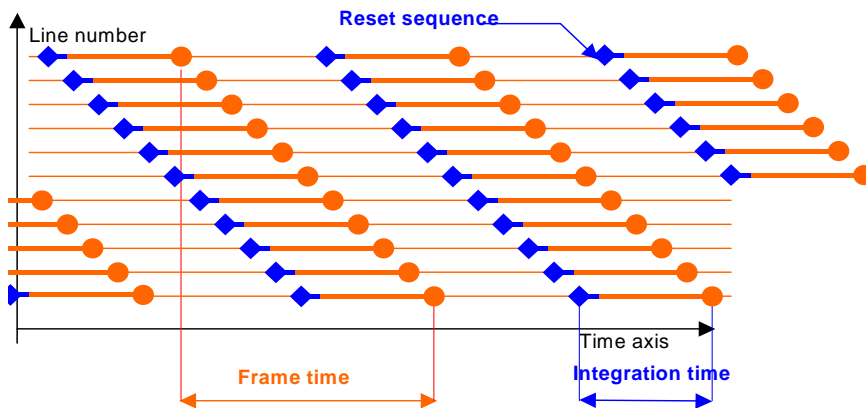
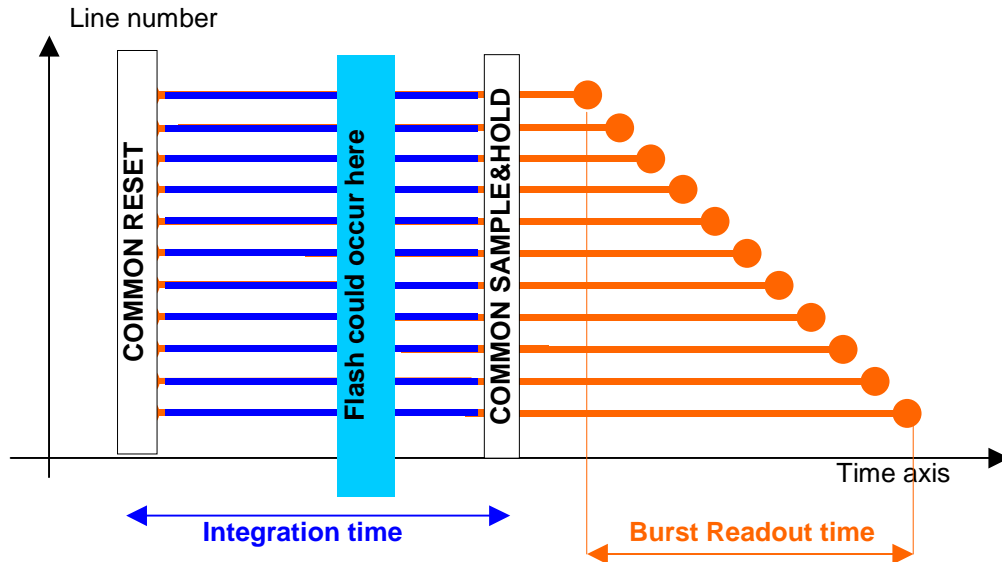


Figure 13. Rolling Shutter Operation



www.DataSheet4U.com



**Figure 14. Synchronous Shutter Operation****Snapshot (Synchronous) Shutter**

A synchronous (global, snapshot) shutter solves the inconvenience found in the rolling shutter. Light integration takes place on all pixels in parallel, although subsequent readout is sequential.

Figure 14 shows the integration and read out sequence for the synchronous shutter. All pixels are light sensitive at the same period of time. The whole pixel core is reset simultaneously and after the integration time all pixel values are sampled together on the storage node inside each pixel. The pixel core is read out line by line after integration. Note that the integration and read out cycle is carry-out in serial; that causes that no integration is possible during read out.

During synchronous shutter mode, the input pins SS\_START and SS\_STOP are used to start and stop the synchronous shutter.

**Sequencer**

Figure 5 on page 4 shows a number of control signals that are needed to operate the sensor in a particular sub-sampling mode with a certain integration time, output amplifier gain, and so on.

Most of these signals are generated on-chip by the sequencer that uses only a few control signals. Make certain that these control signals are generated by the external system:

- n SYS\_CLOCK (X-clock) defines the pixel rate
- n Y\_START pulse indicates the start of a new frame read out
- n Y\_CLOCK selects a new row and starts the row blanking sequence, including the synchronization and loading of the X-register
- n SS\_START and SS\_STOP control the integration period in snapshot shutter mode.

The relative position of the pulses is determined by a number of data bits that are uploaded in internal registers through the serial or parallel interface.

**Internal Registers**

Table 10 on page 12 shows a list of the internal registers with a short description. In the next section, the registers are explained in more detail.



## IBIS5-B-1300 CYII5FM1300AB

Table 10. Internal Registers

| Register | Bit            | Name   | Description  |
|----------|----------------|--|--|
| 0 (0000) | 11:0           | SEQUENCER register   | Default value <11:0>: '000011000100'   |
|          | 0              | SHUTTER_TYPE   | 1 = rolling shutter<br>0 = synchronous shutter                                     |
|          | 1              | FRAME_CAL_MODE   | 0 = fast<br>1 = slow   |
|          | 2              | LINE_CAL_MODE  | 0 = fast<br>1 = slow   |
|          | 3              | CONT_CHARGE  | 1 = 'Continuous' precharge enabled   |
|          | 4              | GRAN_X_SEQ_LSB   | Granularity of the X sequencer clock   |
|          | 5              | GRAN_X_SEQ_MSB   |  |
|          | 6              | GRAN_SS_SEQ_LSB  | Granularity of the SS sequencer clock  |
|          | 7              | GRAN_SS_SEQ_MSB  |  |
|          | 8              | KNEEPOINT_LSB  | Sets reset voltage for multiple slope operation                                    |
|          | 9              | KNEEPOINT_MSB  |  |
|          | 10             | KNEEPOINT_ENABLE   | 1 = Enables multiple slope operation in synchronous shutter mode                   |
| 11       | VDDR_RIGHT_EXT | 1 = Disables circuit that generates VDDR_RIGHT voltage; this allows the application of an external voltage |  |
| 1 (0001) | 11:0           | NROF_PIXELS  | Number of pixels to count (maximum 1280/2)<br>Default value <11:0>: '001001111111' |
| 2 (0010) | 11:0           | NROF_LINES   | Number of lines to count<br>Default value <11:0>: '001111111111'                   |
| 3 (0011) | 11:0           | INT_TIME   | Integration time<br>Default value <11:0>: '111111111111'                           |
| 4 (0100) | 10:0           | X_REG  | X start position (maximum 1280/2)<br>Default value <10:0>: '00000000000'           |
| 5 (0101) | 10:0           | YL_REG   | Y-left start position<br>Default value <10:0>: '00000000000'                       |
| 6 (0110) | 10:0           | YR_REG   | Y-right start position<br>Default value <10:0>: '00000000000'                      |
| 7 (0111) | 7:0            | IMAGE CORE register  | Default value <7:0>: '00000000'  |
|          | 0              | TEST_EVEN  | Test even columns  |
|          | 1              | TEST_ODD   | Test odd columns   |
|          | 2              | X_SUBSAMPLE  | Enable sub-sampling in X-direction   |
|          | 3              | X_SWAP12   | Swap columns 1-2, 5-6, ...   |
|          | 4              | X_SWAP30   | Swap columns 3-4, 7-8, ...   |
|          | 5              | Y_SUBSAMPLE  | Enable sub-sampling in Y-direction   |
|          | 6              | Y_SWAP12   | Swap rows 1-2, 5-6, ...  |
| 7        | Y_SWAP30       | Swap rows 3-4, 7-8, ...  |  |
| 8 (1000) | 6:0            | AMPLIFIER register   | Default value <6:0>: '1010000'   |
|          | 0              | GAIN<0>  | Output amplifier gain setting  |
|          | 1              | GAIN<1>  |  |
|          | 2              | GAIN<2>  |  |
|          | 3              | GAIN<3>  |  |
|          | 4              | UNITY  | 1 = Amplifier in unity gain mode   |
|          | 5              | DUAL_OUT   | 1 = Activates second output  |
| 6        | STANDBY        | 0 = Amplifier in standby mode  |  |



## IBIS5-B-1300 CYII5FM1300AB

**Table 10. Internal Registers** (continued)

| Register  | Bit | Name         | Description   |
|-----------|-----|--------------|---|
| 9 (1001)  | 6:0 | DACRAW_REG   | Amplifier DAC raw offset<br>Default value <6:0>: '1000000'  |
| 10 (1010) | 6:0 | DACFINE_REG  | Amplifier DAC fine offset<br>Default value <6:0>: '1000000' |
| 11 (1011) | 2:0 | ADC register | Default value <2:0>: '011'                                  |
|           | 0   | TRISTATE_OUT | 0 = Output bus in tri-state                                 |
|           | 1   | GAMMA        | 0 = Gamma-correction on                                     |
|           | 2   | BIT_INV      | 1 = Bit inversion on output bus                             |
| 12 (1100) |     | Reserved     |   |
| 13 (1101) |     | Reserved     |   |
| 14 (1110) |     | Reserved     |   |
| 15 (1111) |     | Reserved     |   |

### Detailed Description of the Internal Registers

#### Sequencer register (7:0)

##### 1. Shutter type (bit 0).

The IBIS5-B-1300 image sensor has two shutter types:

0 = synchronous shutter.

1 = rolling shutter.

##### 2. Output amplifier calibration (bits 1 and 2).

Bits FRAME\_CAL\_MODE and LINE\_CAL\_MODE define the calibration mode of the output amplifier.

During every row-blanking period, a calibration is done of the output amplifier. There are two calibration modes. The FAST mode (= 0) forces a calibration in one cycle but is not so accurate and suffers from KTC noise. The SLOW mode (= 1) only makes incremental adjustments and is noise free.

Approximately 200 or more 'slow' calibrations have the same effect as one 'fast' calibration.

Different calibration modes are set at the beginning of the frame (FRAME\_CAL\_MODE bit) and for every subsequent line that is read (LINE\_CAL\_MODE bit). The Y\_START input defines the beginning of a frame, Y\_CLOCK defines the beginning of a new row.

##### 3. Continuous charge (bit 3).

Some applications may require the use continuous charging of the pixel columns instead of a pre-charge on every line sample operation.

Setting bit CONT\_CHARGE to '1' activates this function. The resistor connected to pin PC\_CMD controls the current level on every pixel column.

##### 4. Internal clock granularities (bits 4, 5, 6 and 7).

The system clock is divided several times on-chip.

Half the system clock rate clocks the X-shift-register that controls the column/pixel readout. Odd and even pixel columns are switched to two separate buses. In the output amplifier the

pixel signals on the two buses are combined into one pixel stream at the same frequency as SYS\_CLOCK.

Use the bits GRAN\_SS\_SEQ\_MSB (bit 7) and GRAN\_SS\_SEQ\_LSB (bit 6) to program the clock that drives the 'snapshot' or synchronous shutter sequencer.

This way the integration time in synchronous shutter mode is a multiple of 32, 64, 128, or 256 times the system clock period. To overcome global reset issues, use the longest SS granularity (bits 6 and 7 set to '1').

**Table 11. SS Sequencer Clock Granularities**

| GRAN_SS_SEQ_MSB/<br>LSB | SS-Sequencer<br>Clock | Integration<br>Time Step <sup>[2]</sup> |
|-------------------------|-----------------------|---|
| 00                      | 32 x SYS_CLOCK        | 800 ns                                  |
| 01                      | 64 x SYS_CLOCK        | 1.6 μs                                  |
| 10                      | 128 x SYS_CLOCK       | 3.2 μs                                  |
| 11                      | 256 x SYS_CLOCK       | 6.4 μs                                  |

The clock that drives the X-sequencer is a multiple of 4, 8, 16, or 32 times the system clock. Clocking the X-sequencer at a slower rate (longer row blanking time; pixel read out speed is always equal to the SYSTEM\_CLOCK) results in more signal swing for the same light conditions.

**Table 12. X Sequencer Clock Granularities**

| GRAN_X_SEQ_MSB/<br>LSB | X-Sequencer<br>Clock | Row Blanking<br>Time <sup>[2]</sup> |
|------------------------|----------------------|-------------------------------------|
| 00                     | 4 x SYS_CLOCK        | 3.5 μs                              |
| 01                     | 8 x SYS_CLOCK        | 7 μs                                |
| 10                     | 16 x SYS_CLOCK       | 14 μs                               |
| 11                     | 32 x SYS_CLOCK       | 28 μs                               |

#### Note

- Using a SYS\_CLOCK of 40 MHz (25 ns period).



## IBIS5-B-1300 CYII5FM1300AB

### 5. Pixel reset knee-point for multiple slope operation (bits 8, 9, and 10).

In normal (single slope) mode the pixel reset is controlled from the left side of the image core using the voltage applied on pin VDDR\_LEFT as pixel reset voltage.

In multiple slope operation, apply one or more variable pixel reset voltages.

Bits KNEE\_POINT\_MSB and KNEE\_POINT\_LSB select the on chip-generated pixel reset voltage.

Bit KNEE\_POINT\_ENABLE set to '1' switches control to the right side of the image core so the pixel reset voltage (VDDR\_RIGHT), selected by bits KNEE\_POINT\_MSB/LSB, is used.

Use bit KNEE\_POINT\_ENABLE only for multiple slope operation in synchronous shutter mode. In rolling shutter mode, use only the bits KNEE\_POINT\_MSB/LSB to select the second knee-point in dual slope operation. The actual knee-point depends on VDDH, VDDR\_LEFT and VDDC applied to the sensor.

**Table 13. Multiple Slope Register Settings**

| KNEE_POINT |        | Pixel Reset Voltage (V)VDDR_RIGHT | Knee-point (V) |
|------------|--------|-----------------------------------|----------------|
| MSB/LSB    | ENABLE |                                   |                |
| 00         | 0 or 1 | VDDR_LEFT                         | 0              |
| 01         | 1      | VDDR_LEFT – 0.76                  | + 0.76         |
| 10         | 1      | VDDR_LEFT – 1.52                  | + 1.52         |
| 11         | 1      | VDDR_LEFT – 2.28                  | + 2.28         |

### 6. External Pixel Reset Voltage for Multiple Slope (bit 11)

Setting bit VDDR\_RIGHT\_EXT to '1' disables the circuit that generates the variable pixel reset voltage and uses the voltage externally applied to pin VDDR\_RIGHT as the double/multiple slope reset voltage.

Setting bit VDDR\_RIGHT\_EXT to '0' allows you to monitor the variable pixel reset voltage (used for multiple slope operation) on pin VDDR\_RIGHT.

### NROF\_PIXELS Register (11:0)

After the internal x\_sync is generated (start of the pixel readout of a particular row), the PIXEL\_VALID signal goes high. The PIXEL\_VALID signal goes low when the pixel counter reaches the value loaded in the NROF\_PIXEL register. Due to the fact that two pixels are read at the same clock cycle, you must divide this number by 2 (NROF\_PIXELS = (width of ROI / 2) – 1).

### ROF\_LINES Register (11:0)

After the internal yl\_sync is generated (start of the frame readout with Y\_START), the line counter increases with each Y\_CLOCK pulse until it reaches the value loaded in the NROF\_LINES register and generates a LAST\_LINE pulse.

### INT\_TIME Register (11:0)

Use the INT\_TIME register to set the integration time of the electronic shutter. The interpretation of the INT\_TIME depends on the chosen shutter type (rolling or synchronous).

#### 1. Synchronous shutter.

After the SS\_START pulse is applied an internal counter counts the number of SS granulated clock cycles until it reaches the value loaded in the INT\_TIME register and generates a TIME\_OUT pulse. Use this TIME\_OUT pulse to generate the SS\_STOP pulse to stop the integration. When the INT\_TIME register is used, the maximum integration time is:

$$T_{INT\_MAX} = 212 * 256 \text{ (maximum granularity)} * (40 \text{ MHz}) - 1 = 26.2 \text{ ms.}$$

You can increase this maximum time if you use an external counter to trigger SS\_STOP. Ten is the minimal value that you can load into the INT\_TIME register (see also "Internal clock granularities (bits 4, 5, 6 and 7)." on page 13).

#### 2. Rolling shutter.

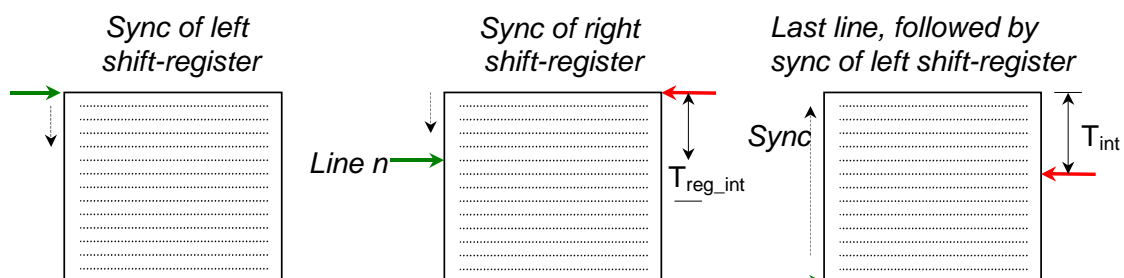
When the Y\_START pulse is applied (start of the frame read-out), the sequencer generates the yl\_sync pulse for the left Y-shift register (read out Y-shift register). This loads the left Y-shift register with the pointer loaded in YL\_REG register. At each Y\_CLOCK pulse, the pointer shifts to the next row and the integration time counter increases until it reaches the value loaded in the INT\_TIME register. At that moment, the sequencer generates the yr\_sync pulse for the right Y-shift register; it loads the right Y-shift register (reset Y-shift register) with the pointer loaded in YR\_REG register (see Figure 15). The integration time counter is reset when the sync for the left Y-shift register is asserted. Both shift registers keep moving until the next sync is asserted (it generates the Y\_START for the left Y-shift register and the sync for the right Y-shift register when the integration time counter reaches the INT\_TIME value).

Treg\_int Difference between the left and right pointer = value set in the INT\_TIME register (number of lines).

The actual integration time is given by:

$$T_{int} \text{ Integration time [ \# lines ]} = \text{NROF\_LINES register} - \text{INT\_TIME register.}$$

**Figure 15. Synchronization of the Shift Registers in Rolling Shutter Mode**





## IBIS5-B-1300 CYII5FM1300AB

### X\_REG Register (10:0)

The X\_REG register determines the start position of the window in the X-direction. In this direction, there are 640 possible starting positions (two pixels are addressed at the same time in one clock cycle). If sub sampling is enabled, only the even pixels are set as starting position (for instance: 0, 2, 4, 6, 8... 638).

### YL\_REG (10:0) and YR\_REG (10:0)

The YL\_REG and YR\_REG registers determine the start position of the window in the Y-direction. In this direction, there are 1024 possible starting positions. In rolling shutter mode the YL\_REG register sets the start position of the read (left) pointer and the YR\_REG sets the start position of the reset (right) pointer. For both shutter types YL\_REG is always equal to YR\_REG.

### Image Core Register (7:0)

Bits 1:0 of the IMAGE\_CORE register define the test mode of the image core. Setting 00 is the default and normal operation mode. In case the bit is set to '1', the odd (bit 1) or even (bit 0) columns are tight to the reset level. If the internal ADC is used, bits 0 and 1 are used to create test pattern to test the sample moment of the ADC. If the ADC sample moment is not chosen correctly, the created test pattern is not black-white-black-etc. (IMAGE\_CORE register set at 1 or 2) or black-black-white-white-black-black (IMAGE\_CORE register set at 9) but grey shadings if the sensor is saturated.

Bits 7:2 of the IMAGE\_CORE register define the sub-sampling mode in the X-direction (bits 4:2) and in the Y-direction (bits 7:5). The sub-sampling modes and corresponding bit setting are given in [Table 6](#) on page 6 and [Table 7](#) on page 6.

### Amplifier Register (6:0)

#### 1. GAIN (bits 3:0)

The gain bits determine the gain setting of the output amplifier. They are only effective if UNITY = 0. The gains and corresponding bit setting are given in [Table 8](#) on page 7.

#### 2. UNITY (bit 4)

In case UNITY = 1, the gain setting of GAIN is bypassed and the gain amplifier is put in unity feedback.

#### 3. DUAL\_OUT (bit 5)

If DUAL\_OUT = 1, the two output amplifiers are active. If DUAL\_OUT = 0, the signals from the two buses are multiplexed to output PXL\_OUT1 which connects to ADC\_IN. The gain amplifier and output driver of the second path are put in standby.

### 4. STANDBY

If STANDBY = 0, the complete output amplifier is put in standby. For normal use, set STANDBY to '1'.

### DAC\_RAW Register (6:0) and DAC\_FINE (6:0) Register

These registers determine the black reference level at the output of the output amplifier. Bit setting 1111111 for the DAC\_RAW register gives the highest offset voltage. Bit setting 0000000 for the DAC\_RAW register gives the lowest offset voltage. Ideally, if the two output paths have no offset mismatch, the DAC\_FINE register is set to 1000000. Deviation from this value is used to compensate the internal mismatch (see "Output Amplifier" on page 7).

### ADC Register (2:0)

#### 1. TRISTATE\_OUT (bit 0)

In case TRISTATE = 0, the ADC\_D<9:0> outputs are in tri-state mode. TRISTATE = 1 for normal operation mode.

#### 2. GAMMA (bit 1)

If GAMMA is set to '1', the ADC input to output conversion is linear; otherwise the conversion follows a 'gamma' law (more contrast in dark parts of the window, lower contrast in the bright parts).

#### 3. BIT\_INV (bit 2)

If BIT\_INV = 1, 0000000000 is the conversion of the lowest possible input voltage, otherwise the bits are inverted.

### Data Interfaces

Two different data interfaces are implemented. They are selected using pins IF\_MODE (pin 12) and SER\_MODE (pin 6).

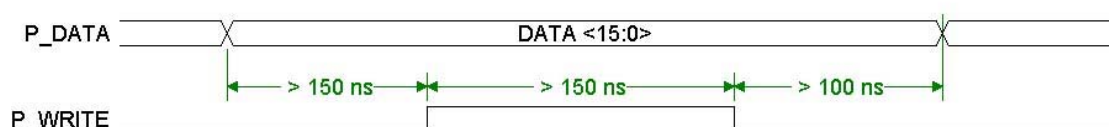
**Table 14. Serial and Parallel Interface Selection**

| IF_MODE | SER_MODE | Selected interface |
|---------|----------|--------------------|
| 1       | X        | Parallel           |
| 0       | 1        | Serial 3 Wire      |
| 0       | 0        | Serial 2 Wire.     |

### Parallel Interface

The parallel interface uses a 16-bit parallel input (P\_DATA (15:0)) to upload new register values. Asserting P\_WRITE loads the parallel data into the internal register of the IBIS5-B-1300 where it is decoded. (See [Figure 16](#). P\_DATA (15:12) address bits REG\_ADDR (3:0); P\_DATA (11:0) data bits REG\_DATA (11:0)).

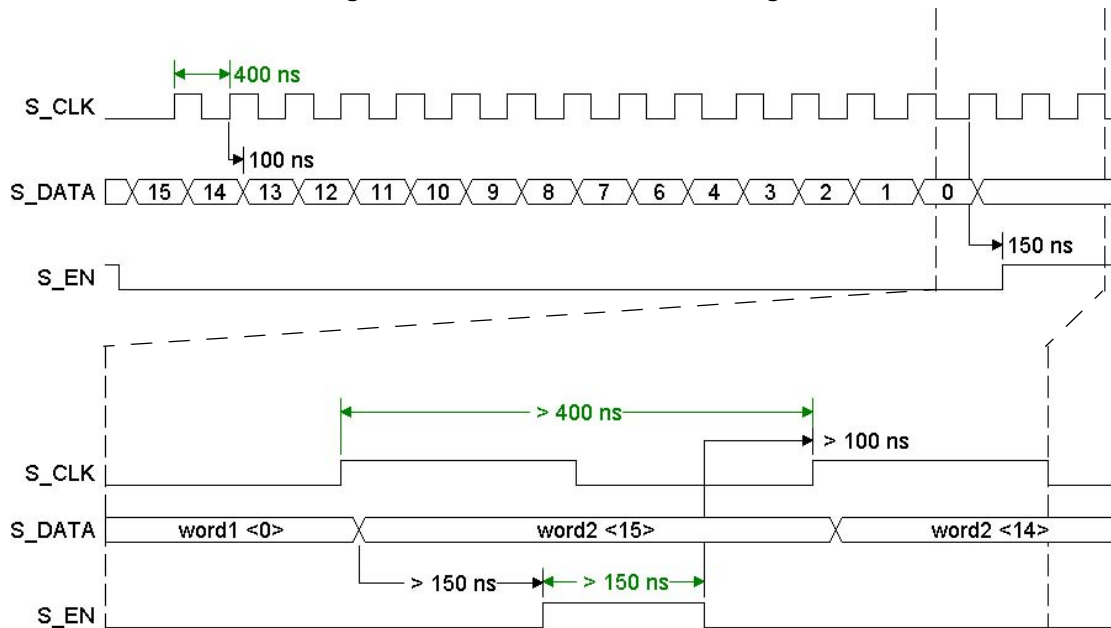
**Figure 16. Parallel Interface Timing**





# IBIS5-B-1300 CYII5FM1300AB

Figure 17. Serial 3-Wire Interface Timing



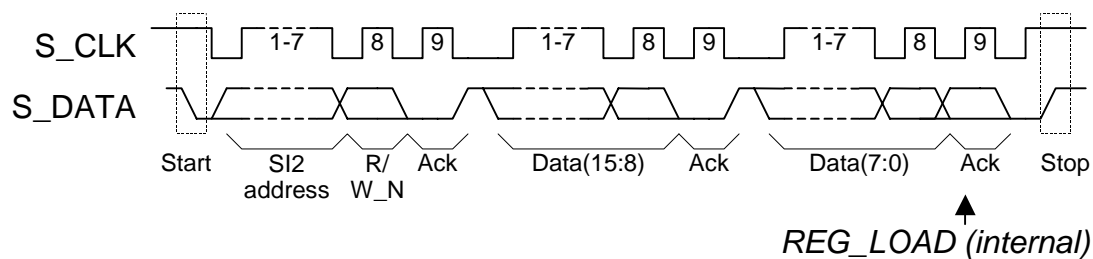
### Serial 3-Wire Interface

The serial 3-wire interface (or serial-to-parallel Interface) uses a serial input to shift the data in the register buffer. When the complete data word is shifted into the register buffer the data word is loaded into the internal register where it is decoded. (See Figure 17. S\_DATA (15:12) address bits REG\_ADDR (3:0); S\_DATA (11:0) data bits REG\_DATA (11:0). When S\_EN is asserted the parallel data is loaded into the internal registers of the IBIS5-A-1300. The maximum tested frequency of S\_DATA is 2.5 MHz.)

### Serial 2-Wire Interface

The serial 2-wire interface is a unidirectional interface (you can only write register values to the sensor; you cannot read anything out). Therefore, the R/W\_N bit (bit 8) is ignored internally. An acknowledge pulse is asserted each time a data word is received successfully. The maximum tested frequency of S\_DATA is 2.5 MHz. (See Figure 18. S\_DATA (15:12) address bits REG\_ADDR (3:0); S\_DATA (11:0) data bits REG\_DATA (11:0)).

Figure 18. Serial 2-Wire Interface Timing







# IBIS5-B-1300 CYII5FM1300AB

## Timing Diagrams

### Timing Requirements

There are six control signals that operate the image sensor:

- SS\_START
- SS\_STOP
- Y\_CLOCK
- Y\_START
- X\_LOAD
- SYS\_CLOCK

The external system generates these control signals with following time constraints to SYS\_CLOCK (rising edge = active edge):

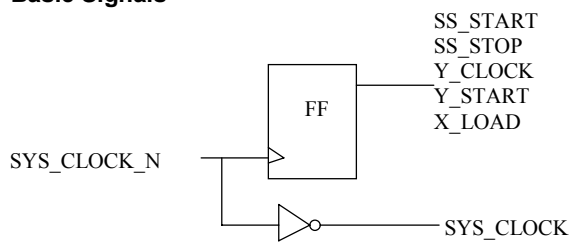
$$T_{SETUP} > 7.5 \text{ ns}$$

$$T_{HOLD} > 7.5 \text{ ns}$$

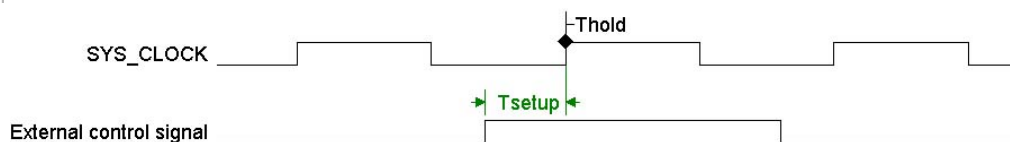
It is important that these signals are free of any glitches.

Figure 19 shows a recommended schematic for generating the basic signals and to avoid any timing problems.

**Figure 19. Recommended Schematic for Generating Basic Signals**

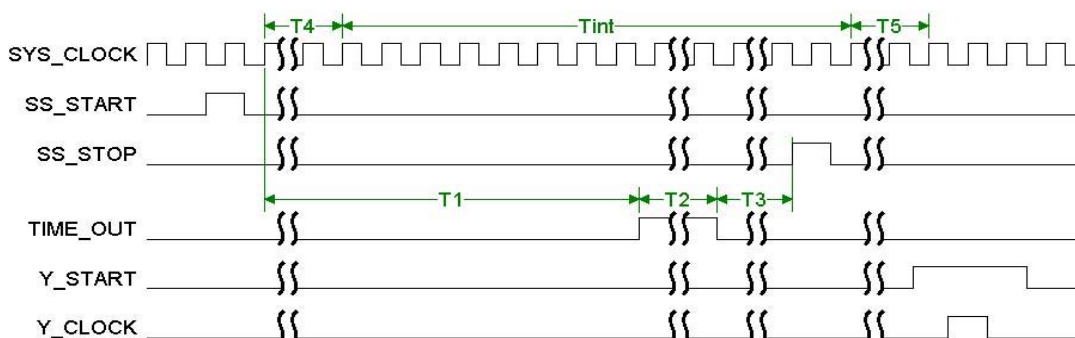


**Figure 20. Relative Timing of the 5 Sequencer Control Signal**



www.DataSheet4U.com

**Figure 21. Synchronous Shutter: Single Slope Integration**



### Synchronous Shutter: Single Slope Integration

SS\_START and SS\_STOP must change on the falling edge of the SYS\_CLOCK ( $T_{setup}$  and  $T_{hold} > 7.5 \text{ ns}$ ). Make certain that the pulse width of both signals is a minimum of 1 SYS\_CLOCK cycle. As long as SS\_START or SS\_STOP are asserted, the sequencer stays in a suspended state. (See Figure 21.)

$T_1$ —Time counted by the integration timer until the value of INT\_TIME register is reached. The integration timer is clocked by the granulated SS-sequencer clock.

$T_2$ —TIME\_OUT signal stays high for one granulated SS-sequencer clock period.

$T_3$ —There are no constraints for this time. Use the TIME\_OUT signal to trigger the SS\_STOP pin (or use an external counter to trigger SS\_STOP); you cannot tie both signals together.

$T_4$ —During this time, the SS-sequencer applies the control signals to reset the image core and start integration. This takes four granulated SS-sequencer clock periods. The integration time counter starts counting at the first rising edge after the falling edge of SS\_START.

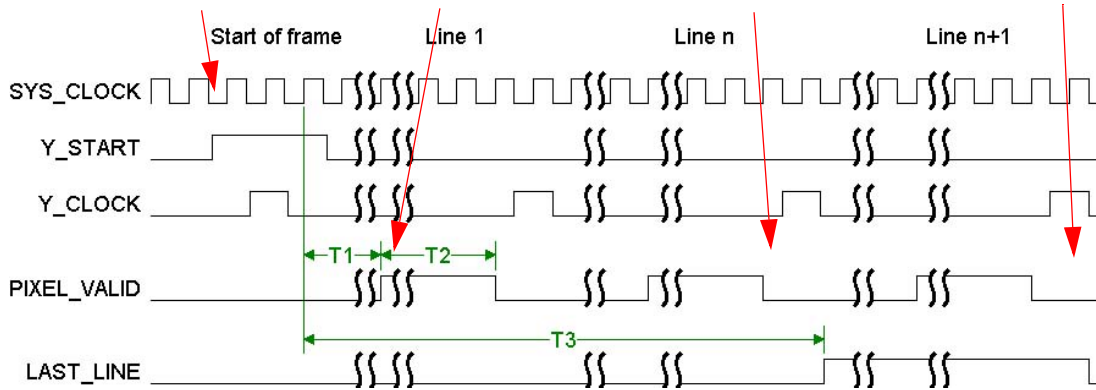
$T_5$ —The SS-sequencer puts the image core in a readable state. It takes two granulated SS-sequencer clock periods.

$T_{int}$ —The 'real' integration or exposure time.



# IBIS5-B-1300 CYII5FM1300AB

Figure 22. Synchronous Shutter: Pixel Read Out



## Synchronous Shutter: Pixel Readout

### Basic Operation

Y\_START and Y\_CLOCK must change on the falling edge of the SYS\_CLOCK (Tsetup and Thold > 7.5 ns). Make certain that the pulse width is a minimum of one clock cycle for Y\_CLOCK and three clock cycles for Y\_START. As long as Y\_CLOCK is applied, the sequencer stays in a suspended state. (See Figure 22.)

T<sub>1</sub>—Row blanking time: During this period, the X-sequencer generates the control signals to sample the pixel signal and pixel reset levels (double sampling fpn-correction), and starts the readout of one line. The row blanking time depends on the granularity of the X-sequencer clock (see Table 15).

Table 15. Row Blanking Time as Function of X-Sequencer Granularity

| Granularity<br>N <sub>GRAN</sub> | T <sub>1</sub> (μs)<br>= 35 x N <sub>GRAN</sub> x T <sub>SYS_CLOCK</sub> | GRAN_X_SEQ<br>MSB/LSB |
|----------------------------------|--|-----------------------|
| x 4                              | 140 x T <sub>SYS_CLOCK</sub> = 3.5                                       | 00                    |
| x 8                              | 280 x T <sub>SYS_CLOCK</sub> = 7.0                                       | 01                    |
| x 16                             | 560 x T <sub>SYS_CLOCK</sub> = 14.0                                      | 10                    |
| x 32                             | 1120 x T <sub>SYS_CLOCK</sub> = 28.0                                     | 11                    |

T<sub>2</sub>—Pixels counted by pixel counter until the value of NROF\_PIXELS register is reached. PIXEL\_VALID goes high when the internal X\_SYNC signal is generated, in other words when the readout of the pixels is started. PIXEL\_VALID goes low when the pixel counter reaches the value loaded in the NROF\_PIXELS register (after a complete row read out).

T<sub>3</sub>—LAST\_LINE goes high when the line counter reaches the value loaded in the NROF\_LINES register and stays high for one line period (until the next falling edge of Y-CLOCK).

On Y\_START the left Y-shift-register of the image core is loaded with the YL-pointer that is loaded in to register YL\_REG.

### Pixel Output

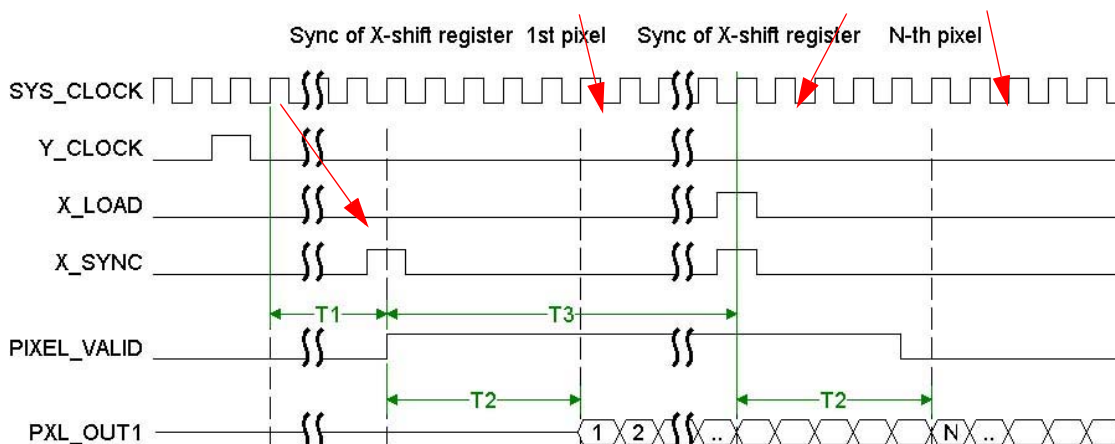
The pixel signal at the PXL\_OUT1 output becomes valid after five SYS\_CLOCK cycles when the internal X\_SYNC (= start of PIXEL\_VALID output or external X\_LOAD pulse) pulse is asserted. (See Figure 23.)

T<sub>1</sub>—Row blanking time (see Table 15).

T<sub>2</sub>—5 SYS\_CLOCK cycles.

T<sub>3</sub>—Time for new X-pointer position upload in X\_REG register (see "Windowing in X-direction" on page 20 for more details).

Figure 23. Pixel Output

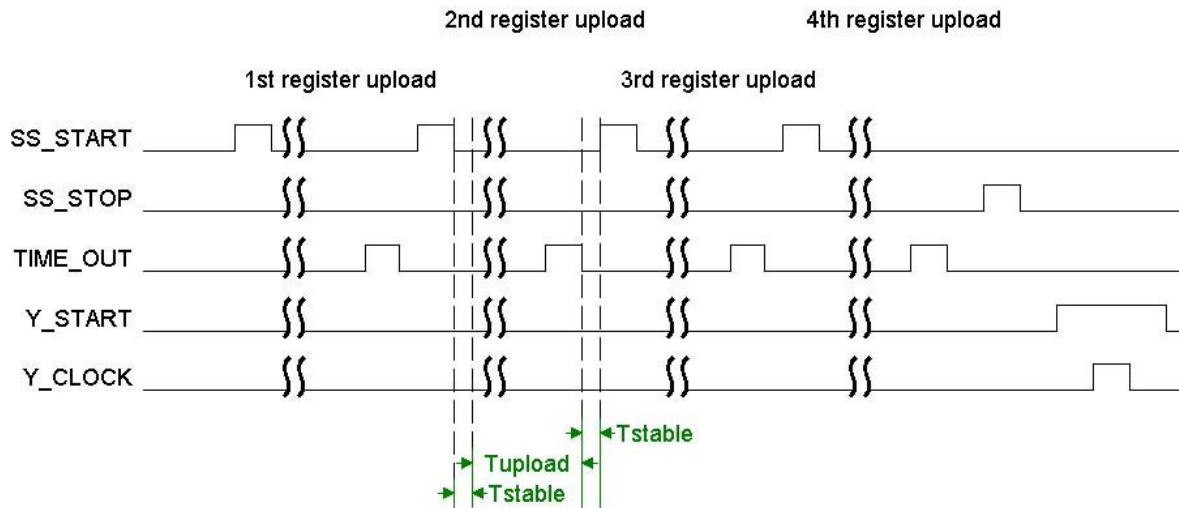




## IBIS5-B-1300 CYII5FM1300AB

### Synchronous Shutter: Multiple Slope Integration

Figure 24. Multiple Slope Integration



Use up to four different pixel reset voltages during multiple slope operation in synchronous shutter mode. This is done by uploading new values to register bits KNEEPOINT\_MSB/LSB/ENABLE before a new SS\_START pulse is applied.

Set bit KNEEPOINT\_ENABLE high to do a pixel reset with a lower voltage.

Set bits KNEEPOINT\_MSB/LSB/ENABLE back to '0' before the SS\_STOP pulse is applied. Every time an SS\_START pulse is applied, the integration time counter is reset.

Table 16. Multiple Slope Register Settings

|                     | Kneepoint |        |
|---------------------|-----------|--------|
|                     | MSB/LSB   | Enable |
| Initial Setup       | 00        | 0      |
| 1st Register Upload | 01        | 1      |
| 2nd Register Upload | 10        | 1      |
| 3th Register Upload | 11        | 1      |
| 4th Register Upload | 00        | 0      |

Upload the register after time T<sub>stable</sub>, otherwise, the change affects the SS-sequencer resulting in a bad pixel reset. T<sub>stable</sub> depends on the granularity of the SS-sequencer clock (see Table 17).

Table 17. T<sub>stable</sub> for Different Granularity Settings

| Granularity<br>N <sub>GRAN</sub> | T <sub>stable</sub> (μs)<br>= 5 x N <sub>GRAN</sub> x T <sub>SYS_CLOCK</sub> | GRAN_SS_SEQ<br>MSB/LSB |
|----------------------------------|--|------------------------|
| x 32                             | 160 x T <sub>SYS_CLOCK</sub> = 4   | 00                     |
| x 64                             | 320 x T <sub>SYS_CLOCK</sub> = 8   | 01                     |
| x 128                            | 640 x T <sub>SYS_CLOCK</sub> = 16  | 10                     |
| x 256                            | 1280 x T <sub>SYS_CLOCK</sub> = 32   | 11                     |

T<sub>upload</sub> depends on the interface mode used to upload the registers.

Table 18. T<sub>upload</sub> for Different Interface Modes

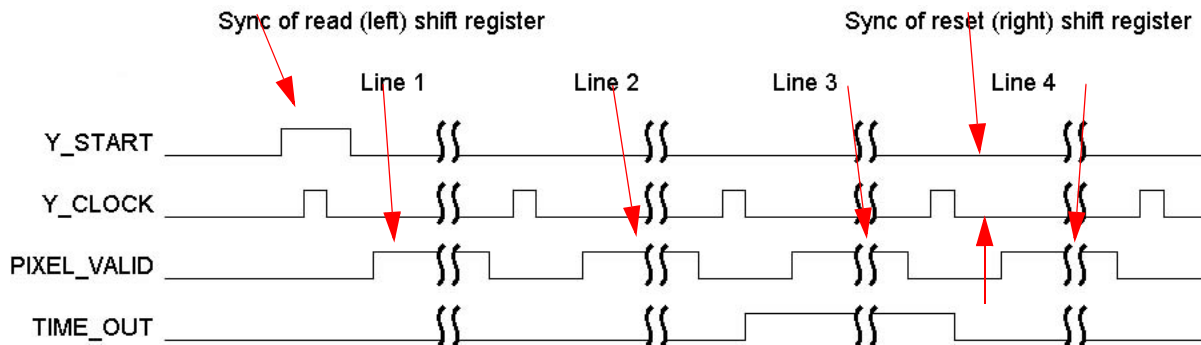
| Interface Mode | T <sub>upload</sub> (μs) |
|----------------|--------------------------|
| Parallel       | 1                        |
| Serial 3-wire  | 8                        |



# IBIS5-B-1300 CYII5FM1300AB

## Rolling Shutter Operation

Figure 25. Rolling Shutter Operation



The integration of the light in the image sensor is done during readout of the other lines.

The only difference with synchronous shutter is that the **TIME\_OUT** pin is used to indicate when the **Y\_SYNC** pulse for the right Y-shift-register (reset Y-shift register) is generated. This loads the right Y-shift-register with the pointer loaded in register **YR\_REG**. The **Y\_SYNC** pulse for the left Y-shift register (read Y-shift register) is generated with **Y\_START**.

The **INT\_TIME** register defines how many lines to count before the **Y\_SYNC** of the right Y-shift-register is generated, hence defining the integration time. See also “**INT\_TIME Register (11:0)**” on page 14 for a detailed description of the rolling shutter operation.

$$T_{int} \text{ Integration time [\# lines]} = \text{register(NROF\_LINES)} - \text{register(INT\_TIME)}$$

**Note** For normal operation the values of the **YL\_REG** and **YR\_REG** registers are equal.

## Windowing in X-direction

An **X\_LOAD** pulse overrides the internal **X\_SYNC** signal, loading a new X-pointer (stored in the **X\_REG** register) into the X-shift-register.

The **X\_LOAD** pulse has to appear on the falling edge of **SYS\_CLOCK** and has to remain high for two **SYS\_CLOCK** cycles overlapping two rising edges of **SYS\_CLOCK**. The new X-pointer is loaded on one of the two rising edges of **SYS\_CLOCK**.

The available time to upload the register is  $T_{load}$ ; it is defined from the previous register load to the rising edge of **X\_LOAD**. It depends on the settling time of the register and the X-decoder.

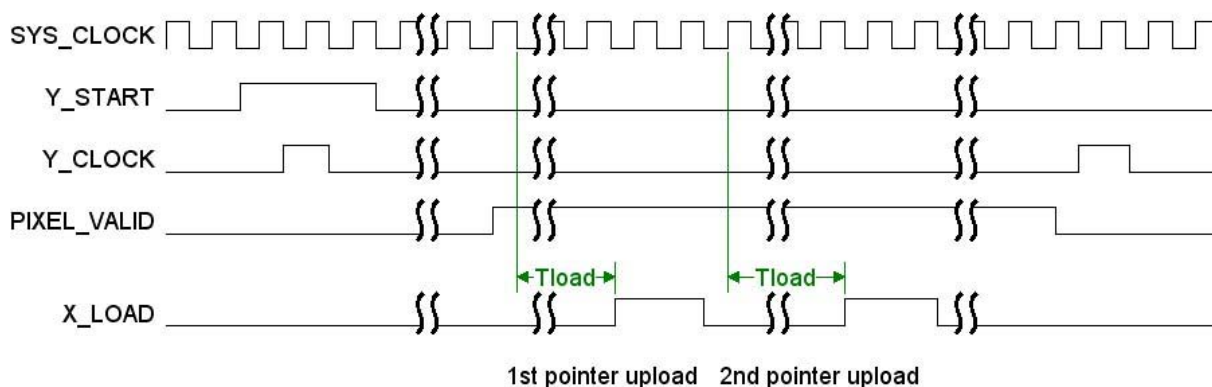
The actual time to load the register itself depends on the interface mode that is used.

The parallel interface is the fastest.

Table 19.  $T_{load}$  for Different Interfaces

| Interface Mode     | $T_{load}$ (µs) |                                    |
|--------------------|-----------------|------------------------------------|
| Parallel interface | 1               | (about 40 <b>SYS_CLOCK</b> cycles) |
| Serial 3 Wire      | 16              | (at 2.5 MHz data rate)             |

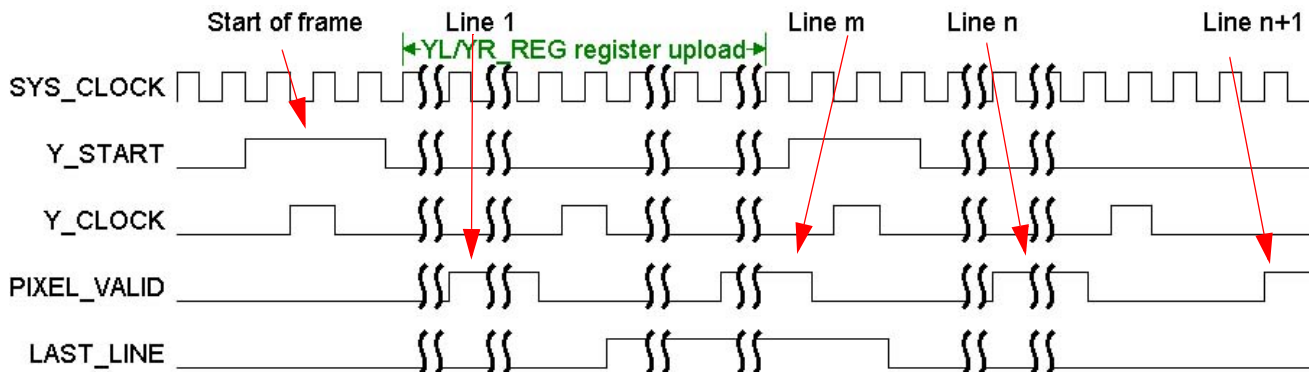
Figure 26. Windowing in the X-Direction





## Windowing in Y-direction

Figure 27. Windowing in the Y-Direction



Reapply the Y\_START pulse after loading a new Y-pointer value into the YL\_REG and YR\_REG registers to load a new Y-pointer into the Y-shift-register.

Every time a Y\_START pulse appears, a frame calibration of the output amplifier occurs.

### Initialization (Start-Up Behavior)

To avoid any high current consumption at start-up, apply the SYS\_CLOCK signal as soon as possible after or even before power on of the image sensor.

After power on of the image sensor, apply SYS\_RESET for a minimum of five SYS\_CLOCK periods to ensure a proper reset of the on-chip sequencer and timing circuitry. All internal registers are set to '0' after SYS\_RESET is applied.

Since all the IBIS5-B-1300 control signals are active high, apply a low level (before SYS\_RESET occurs) to these pins at start up to avoid latch up.



## IBIS5-B-1300 CYII5FM1300AB

### Pin List

The IBIS5-B-1300 image sensor is packaged in a leadless ceramic carrier (LCC package). Table 20 lists all the pins and their functions. There are 84 pins total.

Table 20. Pin List<sup>[3, 4, 5]</sup>

| Pin | Pin Name  | Pin Type | Pin Description  |
|-----|-----------|----------|--|
| 1   | P_DATA<8> | Input    | Digital input. Data parallel interface.  |
| 2   | P_WR      | Input    | Digital input (active high). Parallel write.   |
| 3   | S_CLK     | Input    | Digital input. Clock signal of serial interface.   |
| 4   | S_DATA    | Input    | Digital input/output. Data of serial interface.  |
| 5   | S_EN      | Input    | Digital input (active low). Enable of serial 3-wire interface.   |
| 6   | SER_MODE  | Input    | Digital input. Serial mode enable (1 = Enable serial 3-wire, 0 = Enable serial 2-wire).  |
| 7   | VDDC      | Supply   | Analog supply voltage. Supply voltage of the pixel core [3.3V].  |
| 8   | VDDA      | Supply   | Analog supply voltage. Analog supply voltage of the image sensor [3.3V].   |
| 9   | GNDA      | Ground   | Analog ground. Analog ground of the image sensor.  |
| 10  | GNDD      | Ground   | Digital ground. Digital ground of the image sensor.  |
| 11  | VDDD      | Supply   | Digital supply voltage. Digital supply voltage of the image sensor [3.3V].   |
| 12  | IF_MODE   | Input    | Digital input. Interface mode (1 = parallel; 0 = serial).  |
| 13  | DEC_CMD   | Input    | Analog input. Biasing of decoder stage. Connect to VDDA with R = 50 k $\Omega$ and decouple with C = 100 nF to GNDA.   |
| 14  | Y_START   | Input    | Digital input (active high). Start frame read out.   |
| 15  | Y_CLOCK   | Input    | Digital input (active high). Line clock.   |
| 16  | LAST_LINE | Output   | Digital output. Generates a high level when the last line is read out.   |
| 17  | X_LOAD    | Input    | Digital input (active high). Loads new X-position during read out.   |
| 18  | SYS_CLOCK | Input    | Digital input. System (pixel) clock (40 MHz).  |
| 19  | PXL_VALID | Output   | Digital output. Generates high level during pixel read out.  |
| 20  | SS_START  | Input    | Digital input (active high). Start synchronous shutter operation.  |
| 21  | SS_STOP   | Input    | Digital input (active high). Stop synchronous shutter operation.   |
| 22  | TIME_OUT  | Output   | Digital output.<br>Synchronous shutter: pulse when timeout reached. It is used to trigger SS_STOP; do not tie both signals together.<br>Rolling shutter: pulse when second Y-sync appears. |
| 23  | SYS_RESET | Input    | Digital input (active high). Global system reset.  |
| 24  | EL_BLACK  | Input    | Digital input (active high). Enables electrical black in output amplifier.   |
| 25  | EOSX      | Output   | Digital output. Diagnostic end-of-scan of X-register.  |
| 26  | DAC_VHIGH | Input    | Analog reference input. Biasing of DAC for output dark level. Use this to set the output range of DAC.<br>Default: Connect to VDDA with R = 0 $\Omega$ .                                   |
| 27  | DAC_VLOW  | Input    | Analog reference input. Biasing of DAC for output dark level. Use this to set the output range of DAC.<br>Default: Connect to GND A with R = 0 $\Omega$ .                                  |
| 28  | PXL_OUT1  | Output   | Analog output. Analog pixel output 1.  |

#### Notes

- You can connect all pins with the same name together.
- All digital input are active high (unless mentioned otherwise).
- Tie all digital inputs that are not used to GND (inactive level).



## IBIS5-B-1300 CYII5FM1300AB

Table 20. Pin List<sup>[3, 4, 5]</sup> (continued)

| Pin | Pin Name    | Pin Type | Pin Description  |
|-----|-------------|----------|--|
| 29  | PXL_OUT2    | Output   | Analog output. Analog pixel output 2. Leave not connected if not used.   |
| 30  | AMP_CMD     | Input    | Analog input. Biasing of the output amplifier. Connect to VDDA with R = 50 kΩ and decouple with C = 100 nF to GNDA.              |
| 31  | COL_CMD     | Input    | Analog input. Biasing of the column amplifiers. Connect to VDDA with R = 50 kΩ and decouple with C = 100 nF to GNDA.             |
| 32  | PC_CMD      | Input    | Analog input. Pre-charge bias. Connect to VDDA with R = 25 kΩ and decouple with C = 100 nF to GNDA.                              |
| 33  | VDDD        | Supply   | Digital supply. Digital supply voltage of the image sensor [3.3V].   |
| 34  | GNDD        | Ground   | Digital ground. Digital ground of the image sensor.  |
| 35  | GNDA        | Ground   | Analog ground. Analog ground of the image sensor.  |
| 36  | VDDA        | Supply   | Analog supply voltage. Analog supply voltage of the image sensor [3.3V].   |
| 37  | VDDC        | Supply   | Analog supply voltage. Supply voltage of the pixel core [3.3V].  |
| 38  | P_DATA<0>   | Input    | Digital input. Data parallel interface (LSB).  |
| 39  | P_DATA<1>   | Input    | Digital input. Data parallel interface.  |
| 40  | P_DATA<2>   | Input    | Digital input. Data parallel interface.  |
| 41  | P_DATA<3>   | Input    | Digital input. Data parallel interface.  |
| 42  | P_DATA<4>   | Input    | Digital input. Data parallel interface.  |
| 43  | P_DATA<5>   | Input    | Digital input. Data parallel interface.  |
| 44  | P_DATA<6>   | Input    | Digital input. Data parallel interface.  |
| 45  | P_DATA<7>   | Input    | Digital input. Data parallel interface.  |
| 46  | SI2_ADDR<0> | Input    | Digital input. Sets I2C address.   |
| 47  | SI2_ADDR<1> | Input    | Digital input. Sets I2C address.   |
| 48  | SI2_ADDR<2> | Input    | Digital input. Sets I2C address.   |
| 49  | SI2_ADDR<3> | Input    | Digital input. Sets I2C address.   |
| 50  | SI2_ADDR<4> | Input    | Digital input. Sets I2C address.   |
| 51  | GNDAB       | Supply   | Analog supply voltage. Anti-blooming ground.   |
| 52  | VDDR_RIGHT  | Supply   | Analog supply voltage. Variable reset voltage (multiple slope operation). Decouple with 1 μF to GNDA.                            |
| 53  | ADC_VLOW    | Input    | Analog reference input. ADC low reference voltage. Default: Connect to GNDA with R = 1200Ω and decouple with C = 100 nF to GNDA. |
| 54  | ADC_GNDA    | Ground   | Analog ground. ADC analog ground.  |
| 55  | ADC_VDDA    | Supply   | Analog supply voltage. ADC analog supply voltage [3.3V].   |
| 56  | ADC_GNDD    | Ground   | Digital ground. ADC digital ground.  |
| 57  | ADC_VDDD    | Supply   | Digital supply voltage. ADC digital supply voltage [3.3V].   |
| 58  | ADC_CLOCK   | Input    | Digital input. ADC clock (40 MHz).   |
| 59  | ADC_OUT<9>  | Output   | Digital output. ADC data output (MSB).   |
| 60  | ADC_OUT<8>  | Output   | Digital output. ADC data output.   |
| 61  | ADC_OUT<7>  | Output   | Digital output. ADC data output.   |
| 62  | ADC_OUT<6>  | Output   | Digital output. ADC data output.   |
| 63  | ADC_OUT<5>  | Output   | Digital output. ADC data output.   |
| 64  | ADC_OUT<4>  | Output   | Digital output. ADC data output.   |



## IBIS5-B-1300 CYII5FM1300AB

**Table 20. Pin List**<sup>[3, 4, 5]</sup> (continued)

| Pin | Pin Name   | Pin Type | Pin Description   |
|-----|------------|----------|---|
| 65  | ADC_OUT<3> | Output   | Digital output. ADC data output.  |
| 66  | ADC_OUT<2> | Output   | Digital output. ADC data output.  |
| 67  | ADC_OUT<1> | Output   | Digital output. ADC data output.  |
| 68  | ADC_OUT<0> | Output   | Digital output. ADC data output (LSB).  |
| 69  | ADC_IN     | Input    | Analog input. ADC analog input.   |
| 70  | ADC_CMD    | Input    | Analog input. Biasing of the input stage of the ADC. Connect to ADC_VDDA with R = 50 k $\Omega$ and decouple with C = 100 nF to ADC_GNDA. |
| 71  | ADC_VDDD   | Supply   | Digital supply voltage. ADC digital supply voltage [3.3V].  |
| 72  | ADC_GNDA   | Ground   | Analog ground. ADC analog ground.   |
| 73  | ADC_GNDD   | Ground   | Digital ground. ADC digital ground.   |
| 74  | ADC_VDDA   | Supply   | Analog supply voltage. ADC analog supply voltage [3.3V].  |
| 75  | ADC_VHIGH  | Input    | Analog reference input. ADC high reference volt age.Default: Connect to VDDA with R = 360 $\Omega$ and decouple with C = 100 nF to GNDA.  |
| 76  | VDDR_LEFT  | Supply   | Analog supply voltage. High reset level [4.5V].   |
| 77  | VDDH       | Supply   | Analog supply voltage. High supply voltage for HOLD switches in the image core [4.5V]   |
| 78  | P_DATA<15> | Input    | Digital input. Data parallel interface (MSB).   |
| 79  | P_DATA<14> | Input    | Digital input. Data parallel interface.   |
| 80  | P_DATA<13> | Input    | Digital input. Data parallel interface.   |
| 81  | P_DATA<12> | Input    | Digital input. Data parallel interface.   |
| 82  | P_DATA<11> | Input    | Digital input. Data parallel interface.   |
| 83  | P_DATA<10> | Input    | Digital input. Data parallel interface.   |
| 84  | P_DATA<9>  | Input    | Digital input. Data parallel interface.   |





## IBIS5-B-1300 CYII5FM1300AB

### Specifications

#### General Specifications.

Table 21. General Specifications

| Parameter          | Specification  | Remarks  |
|--------------------|--|--|
| Pixel architecture | 4T-pixel   | High fill factor square pixels (based on the high fill factor active pixel sensor technology of Cypress). Patents pending.                             |
| Pixel size         | 6.7 $\mu\text{m}$ x 6.7 $\mu\text{m}$  | The resolution and pixel size results in a 2/3" optical format.  |
| Resolution         | 1280 x 1024  |  |
| Pixel rate         | 40 MHz   | Using a 40 MHz system clock.   |
| Shutter type       | <ul style="list-style-type: none"> <li>Electronic rolling shutter</li> <li>Snapshot shutter</li> </ul> | <ul style="list-style-type: none"> <li>Continuous imaging.</li> <li>Triggered global shutter with integration and readout separate in time.</li> </ul> |
| Full frame rate    | 27 frames/second   | Increases with ROI read out and/or sub sampling.   |

### Electro-Optical Specifications

#### Overview

Table 22. Electro-Optical Specifications

| Parameter                        | Specification                             | Remarks  |
|----------------------------------|---|--|
| FPN (local)                      | <0.20%                                    | RMS % of saturation signal.  |
| PRNU (local)                     | <10%                                      | Peak-to-peak of signal level.  |
| Conversion gain                  | 17.6 $\mu\text{V}/\text{electron}$        | @ output (measured).   |
| Output signal amplitude          | 1V  | At nominal conditions.   |
| Saturation charge                | 62.500 e-                                 |  |
| Sensitivity (peak)               | 715V.m <sup>2</sup> /W.s<br>8.40 V/lux.s  | @ 650 nm<br>(85 lux = 1 W/m <sup>2</sup> ).  |
| Sensitivity (visible)            | 572 V.m <sup>2</sup> /W.s<br>3.51 V/lux.s | 400-700 nm<br>(163 lux = 1 W/m <sup>2</sup> ).   |
| Peak QE * FF Peak Spectral Resp. | 30%0.16 A/W                               | Average QE*FF = 22% (visible range).<br>Average SR*FF = 0.1 A/W (visible range).<br>See spectral response curve. |
| Fill factor                      | 40%                                       | Light sensitive part of pixel (measured).  |
| Dark current                     | 7.22 mV/s<br>410e-/s                      | Typical value of average dark current of the whole pixel array (@ 21 °C).  |
| Dark Signal Non Uniformity       | 7 mV/s<br>400 e-/s                        | Dark current RMS value (@ 21 °C).  |
| Temporal noise                   | 40 RMS e-                                 | Measured at digital output (in the dark).  |
| S/N Ratio                        | 1563:1 (64 dB)                            | Measured at digital output (in the dark).  |
| Spectral sensitivity range       | 400 - 1000 nm                             |  |
| Optical cross talk               | 16%                                       | To the first neighboring pixel.  |
| Parasitic Sensitivity            | 3%  | Averaged over spectrum   |
| Power dissipation                | 175 mWatt                                 | Typical (including ADCs).  |



## IBIS5-B-1300 CYII5FM1300AB

### Spectral Response Curve

Figure 28. Spectral response curve

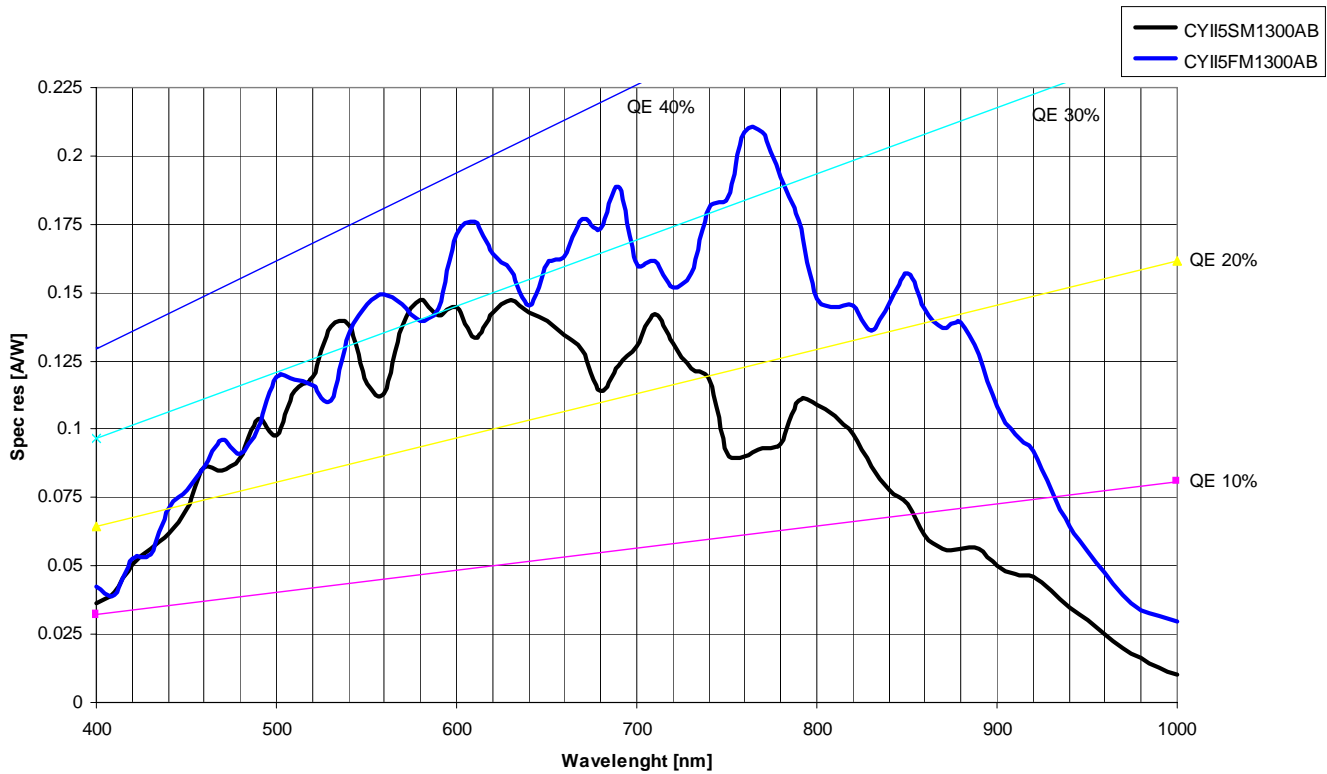


Figure 28 shows the spectral response characteristic for the IBIS5-B-1300 (CYII5SM1300AB) and the IBIS-5-BE-1300 (CYII5FM1300AB). The curve is measured directly on the pixels. It includes effects of non-sensitive areas in the pixel, for example, interconnection lines. The sensor is light sensitive between 400 and 1000 nm. The peak QE \* FF is 30%, approximately around 650 nm. In view of a fill factor of 40%, the QE is thus close to 75% between 500 and 700 nm. The IBIS5-BE-1300 has superior response in the NIR region (700-900 nm). For more information about the IBIS5-B-1300, refer to "IBIS5-BE-1300 (CYII5FM1300AB)" on page 27.



## IBIS5-B-1300 CYII5FM1300AB

### Electro-voltaic Response Curve

Figure 29. Electro-Voltaic Response Curve

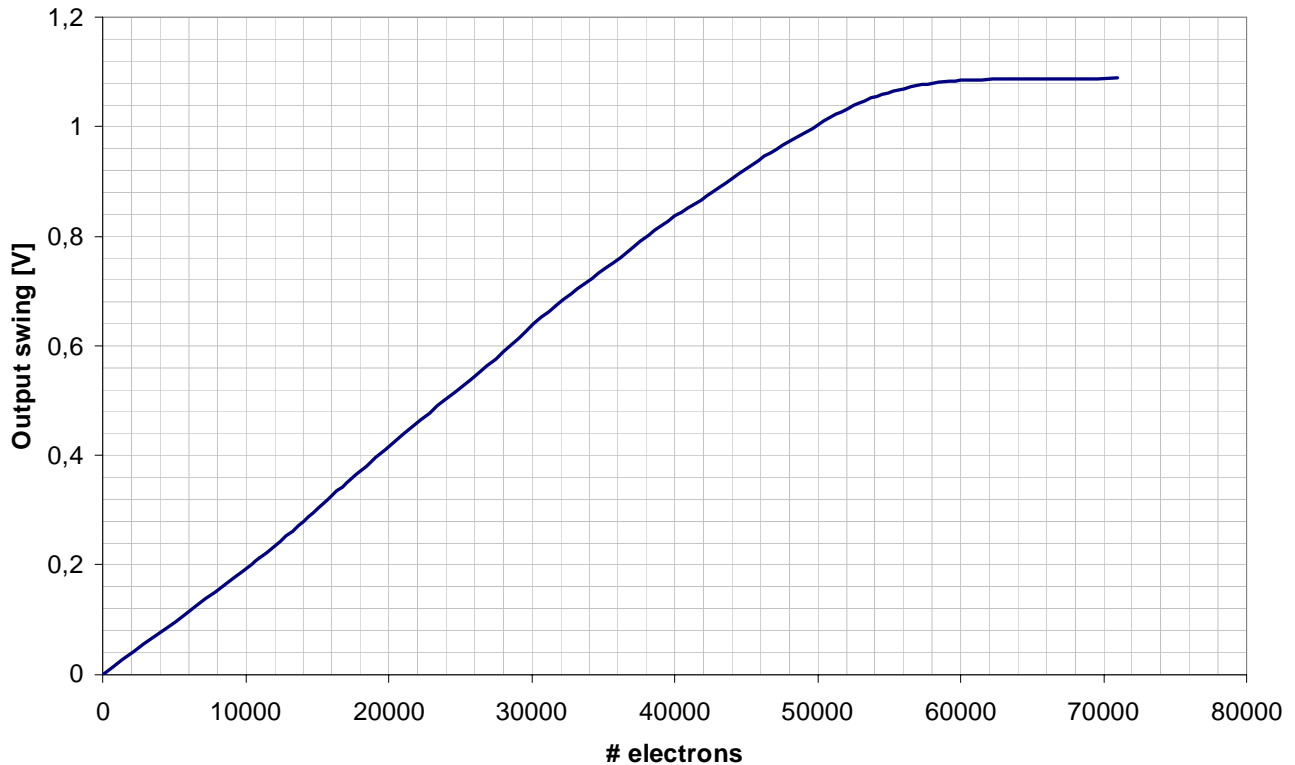


Figure 29 shows the pixel response curve in linear response mode. This curve is the relation between the electrons detected in the pixel and the output signal. The resulting voltage-electron curve is independent of any parameters (integration time, and others). The voltage to electrons conversion gain is 17.6  $\mu\text{V}/\text{electron}$ .

#### IBIS5-BE-1300 (CYII5FM1300AB)

The IBIS5-BE-1300 is processed on a thicker epitaxial Si layer featuring a superb sensitivity in the NIR (Near Infra Red) wavelengths (700–900 nm). The spectral response curves of the two IBIS5-B-1300 image sensors are shown in Figure 28 on page 26. As many machine vision applications use light sources in the NIR, the IBIS5-BE-1300 sensor has a significant sensitivity advantage in the NIR.

A drawback of the thicker epitaxial layer is a slight performance decrease in MTF (Modular Transfer Function or electrical pixel to pixel cross-talk) as indicated in the Table 23.

Table 23. MTF comparison

| Direction  | Wavelength | IBIS5-B-1300 | IBIS5-BE-1300 |
|------------|------------|--------------|---------------|
| Horizontal | 600        | 0.58         | 0.37          |
| Horizontal | 700        |              | 0.18          |
| Horizontal | 800        |              | 0.16          |
| Horizontal | 900        |              | 0.07          |
| Vertical   | 600        | 0.53         | 0.26          |
| Vertical   | 700        |              | 0.16          |
| Vertical   | 800        |              | 0.13          |
| Vertical   | 900        |              | 0.11          |

The resulting image sharpness is hardly affected by this decreased MTF value.

Both IBIS5-B-1300 versions are fully pin compatible and have identical timing and biasing



## IBIS5-B-1300 CYII5FM1300AB

### Features and General Specifications

**Table 24. Features and General Specifications**

| Feature                       | Specification/Description  |
|-------------------------------|--|
| Electronic shutter types      | 1. Rolling curtain shutter.<br>2. Synchronous (snapshot) shutter.  |
| Windowing (ROI)               | Implemented as scanning of lines/columns from an uploaded position.  |
| Sub-sampling modes:           | 1:2 sub-sampling.<br>Sub-sampling patterns:<br>XXOOXXOO (for Bayer pattern color filter)<br>OOXXOOXX (for Bayer pattern color filter)<br>XOXOXOXOXOXOXOX<br>Identical sub-sample patterns in X- and Y-direction. |
| Extended dynamic range        | In rolling shutter: Normal (1) or double (2) slope.<br>In Synchronous shutter: 1, 2, 3 or 4 slopes.  |
| Digital output                | 10 bit ADC @ 40 MSamples/s.  |
| Programmable gain range       | x1 to x12, in 16 steps of approx. 1.5 dB using 4-bit programming.  |
| Programmable offset           | 128 steps (7 bit).   |
| Supply voltage VDD            | Image core supply: Range from 3.0V to 4.5V<br>Analog supply: Nominal 3.3V<br>Digital: Nominal 3.3V   |
| Logic levels                  | 3.3 V (Digital supply).  |
| Operational temperature range | -30°C to 65°C, with degradation of dark current.   |
| Die size (with scribe lines)  | 10.1 mm by 9.3 mm (x by y).  |
| Package                       | 84 pins LCC.   |

### Electrical Specifications

#### www Absolute Maximum Ratings

**Table 25. Absolute Maximum Ratings**

| Parameter        | Description   | Value       | Unit |
|------------------|---|-------------|------|
| VDD              | DC supply voltage                                     | -0.5 to 4.5 | V    |
| V <sub>IN</sub>  | DC input voltage                                      | -0.5 to 3.8 | V    |
| V <sub>OUT</sub> | DC output voltage                                     | -0.5 to 3.8 | V    |
| I <sub>IO</sub>  | DC current drain per pin; any single input or output. | ± 50        | mA   |
| T <sub>L</sub>   | Lead temperature (5 seconds soldering).               | 350         | °C   |
| T <sub>ST</sub>  | Storage temperature                                   | -30 to +85  | °C   |
| H                | Humidity (relative)                                   | 85% at 85°C |      |
| ESD              | ESD susceptibility                                    | 2000        | V    |

VDD = VDDD = VDDA (VDDD is supply to digital circuit, VDDA to analog circuit).

Stresses beyond those listed under the section [Absolute Maximum Ratings](#) can cause permanent damage to the device. These are stress ratings only and functional operation of the device at these or any other conditions beyond those indicated in the operational sections are not implied. Exposure to absolute maximum rating conditions for extended periods can affect device reliability.



## IBIS5-B-1300 CYII5FM1300AB

### Recommended Operating Conditions

**Table 26. Recommended Operating Conditions**

| Parameter      | Description                               | Min  | Typ  | Max  | Unit |
|----------------|---|------|------|------|------|
| VDDH           | Voltage on HOLD switches.                 | +3.3 | +4.5 | +4.5 | V    |
| VDDR_LEFT      | Highest reset voltage.                    | +3.3 | +4.5 | +4.5 | V    |
| VDDC           | Pixel core voltage.                       | +2.5 | +3.0 | +3.3 | V    |
| VDDA           | Analog supply voltage of the image core.  | +3.0 | +3.3 | +3.6 | V    |
| VDDD           | Digital supply voltage of the image core. | +3.0 | +3.3 | +3.6 | V    |
| GND_A          | Analog ground                             | -0.5 | 0    | +0.5 | V    |
| GND_D          | Digital ground                            | -0.5 | 0    | +0.5 | V    |
| GND_AB         | Anti-blooming ground.                     | -0.5 | 0    | +0.5 | V    |
| T <sub>A</sub> | Commercial operating temperature.         | 0    | 30   | 60   | °C   |

All parameters are characterized for DC conditions after thermal equilibrium is established.

Always tie unused inputs to an appropriate logic level, for example, either VDD or GND.

This device contains circuitry to protect the inputs against damage due to high static voltages or electric fields. However, take normal precautions to avoid application of any voltages higher than the maximum rated voltages to this high impedance circuit.

### DC Electrical Characteristics

**Table 27. DC Electrical Characteristics**

| Parameter       | Characteristic            | Condition                            | Min | Max | Unit |
|-----------------|---------------------------|--------------------------------------|-----|-----|------|
| V <sub>IH</sub> | Input high voltage        |                                      | 2.1 |     | V    |
| V <sub>IL</sub> | Input low voltage         |                                      |     | 0.6 | V    |
| I <sub>IN</sub> | Input leakage current     | V <sub>IN</sub> = VDD or GND         | -10 | +10 | μA   |
| V <sub>OH</sub> | Output high voltage       | VDD = min; I <sub>OH</sub> = -100 mA | 2.2 |     | V    |
| V <sub>OL</sub> | Output low voltage        | VDD = min; I <sub>OH</sub> = 100 mA  |     | 0.5 | V    |
| I <sub>DD</sub> | Maximum operating current | System clock <= 40 MHz               | 40  | 60  | mA   |



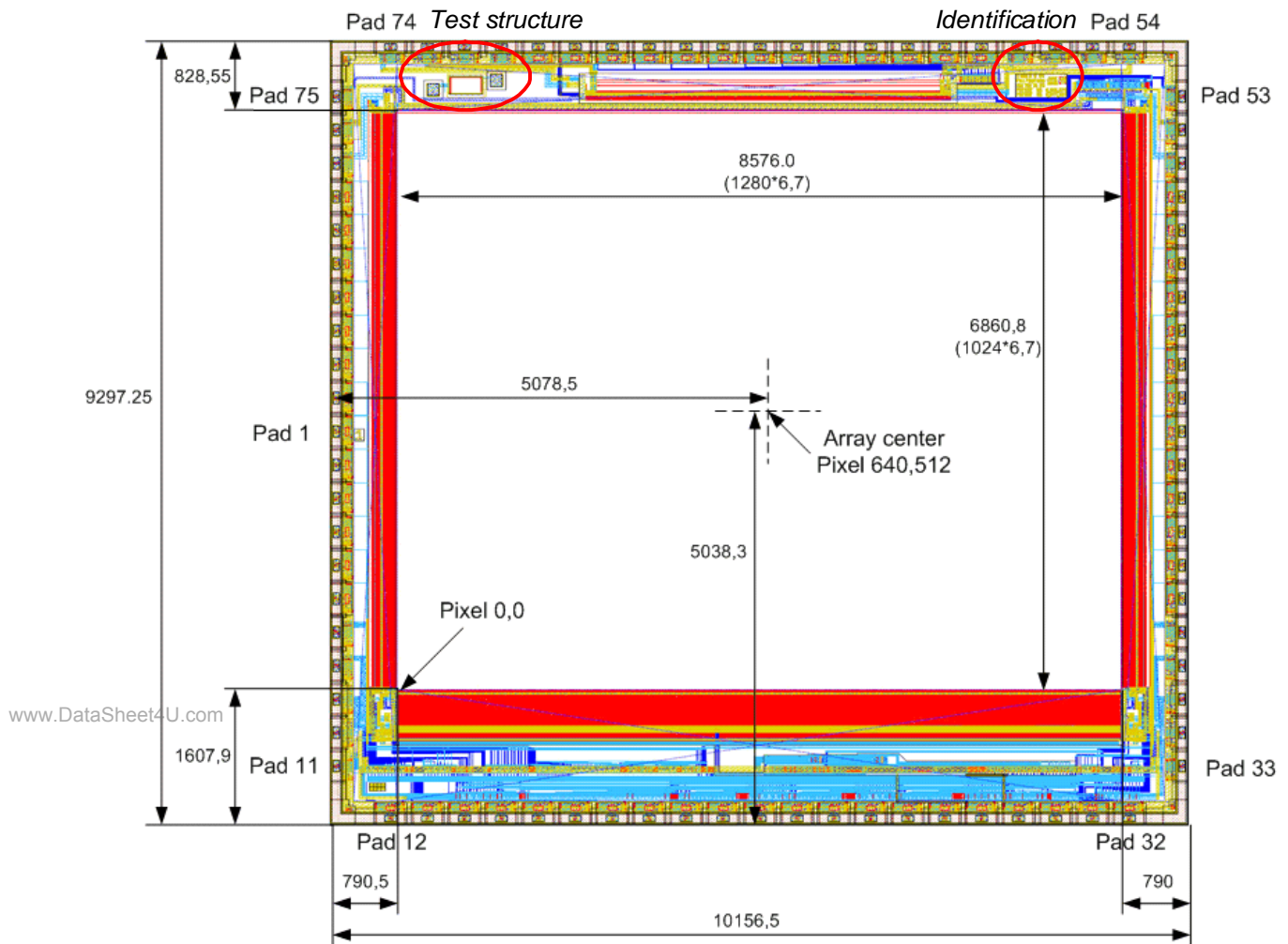
# IBIS5-B-1300 CYII5FM1300AB

## Pad position and Packaging

### Bare Die

The IBIS5-B-1300 image sensor has 84 pins, 21 pins on every edge. The die size from pad-edge to pad-edge (without scribe-line) is: 10156.5  $\mu\text{m}$  (x) by 9297.25  $\mu\text{m}$  (y). Scribe lines take about 100 to 150  $\mu\text{m}$  extra on each side. Pin 1 is located in the middle of the left side, indicated by a '1' on the layout. A logo and some identification tags are on the top right of the die.

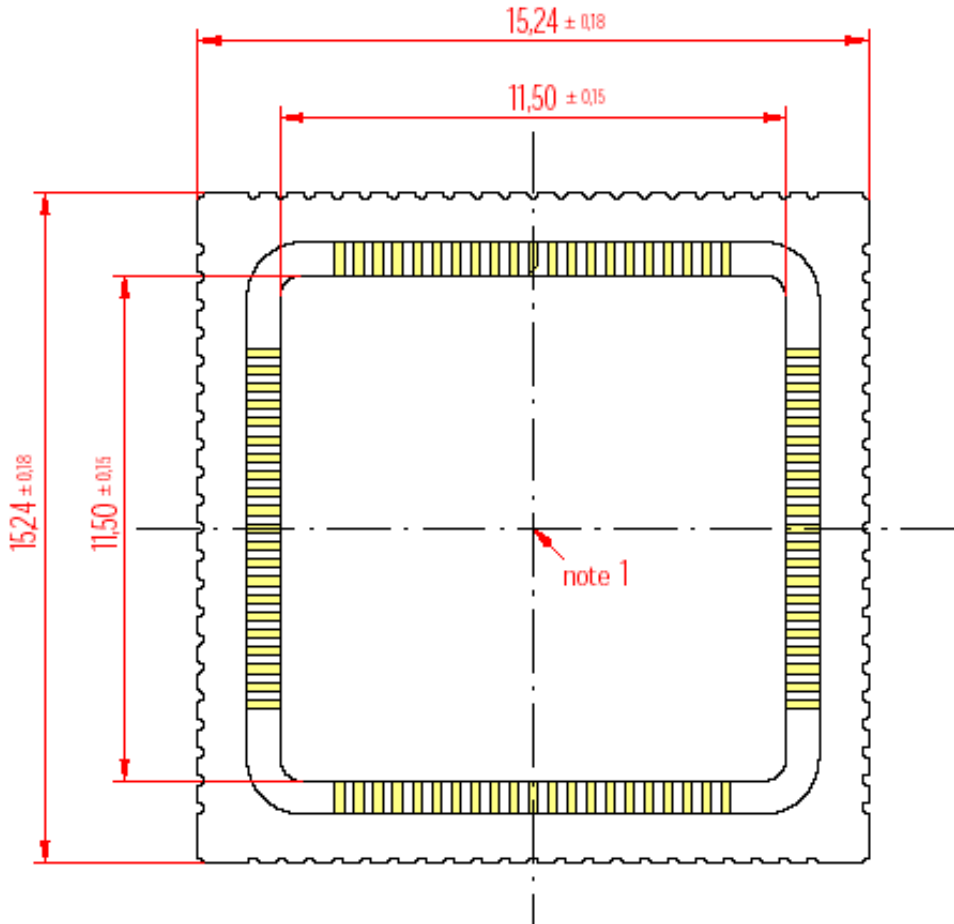
**Figure 30. IBIS5-B-1300 Bare Die Dimensions (All dimensions in  $\mu\text{m}$ )**



**IBIS5-B-1300 in 84-pin LCC Package**

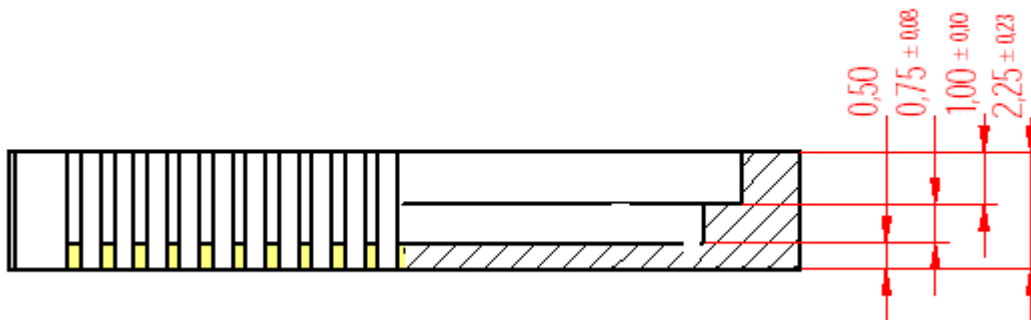
Technical Drawing of 84-pin LCC Package (spec 001-05461-\*\*)

**Figure 31. Top View of the 84-Pin LCC Package (all dimensions in mm)**



www.DataSheet4U.com

**Figure 32. Side View of the 84-pin LCC Package (all dimensions in mm)**



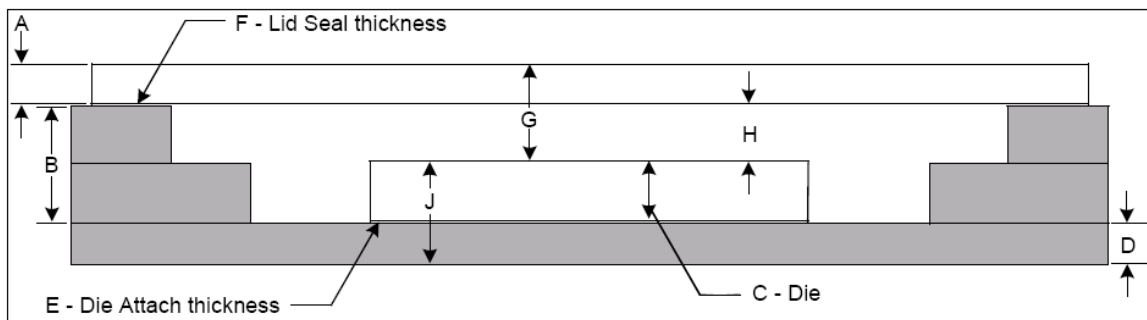


**IBIS5-B-1300 CYII5FM1300AB**

**Table 28. Side View Dimensions**

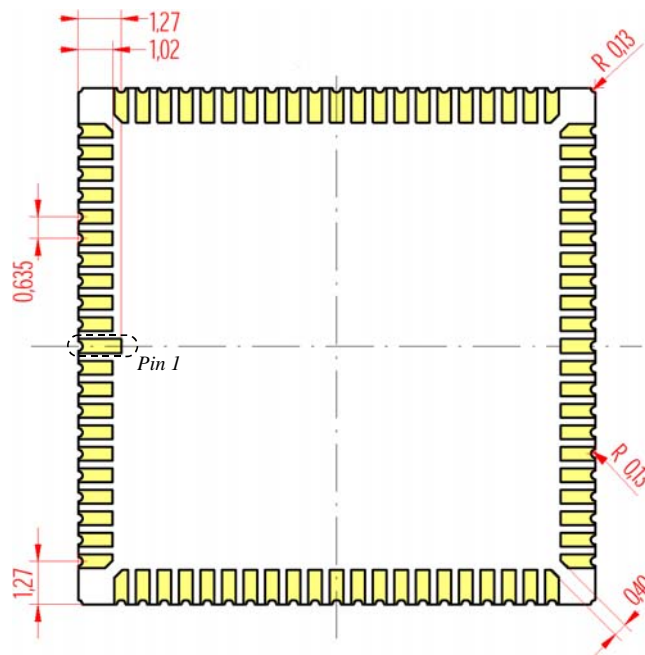
| Dimension | Description                        | (Inch) |       |       | (mm)  |       |       |
|-----------|------------------------------------|--------|-------|-------|-------|-------|-------|
|           |                                    | Min    | Typ   | Max   | Min   | Typ   | Max   |
| A         | Glass (thickness) - mono           | 0.020  | 0.022 | 0.024 | 0.500 | 0.550 | 0.600 |
| B         | Cavity (depth)                     | 0.060  | 0.069 | 0.078 | 1.520 | 1.750 | 1.980 |
| C         | Die - Si (thickness) - mono        |        | 0.029 |       |       | 0.740 |       |
| D         | Bottom layer (thickness)           |        | 0.020 |       |       | 0.500 |       |
| E         | Die attach-bondline (thickness)    | 0.001  | 0.002 | 0.004 | 0.030 | 0.060 | 0.090 |
| F         | Glass attach-bondline (thickness)  | 0.001  | 0.003 | 0.004 | 0.030 | 0.070 | 0.110 |
| G         | Imager to lid-outer surface        |        | 0.062 |       |       | 1.570 |       |
| H         | Imager to lid-inner surface        |        | 0.037 |       |       | 0.950 |       |
| J         | Imager to seating plane of package | 0.050  | 0.051 | 0.052 | 1.270 | 1.300 | 1.330 |

**Figure 33. Side View Dimensions**



**Figure 34. Bottom View of the 84-pin LCC Package (all dimensions in mm)**

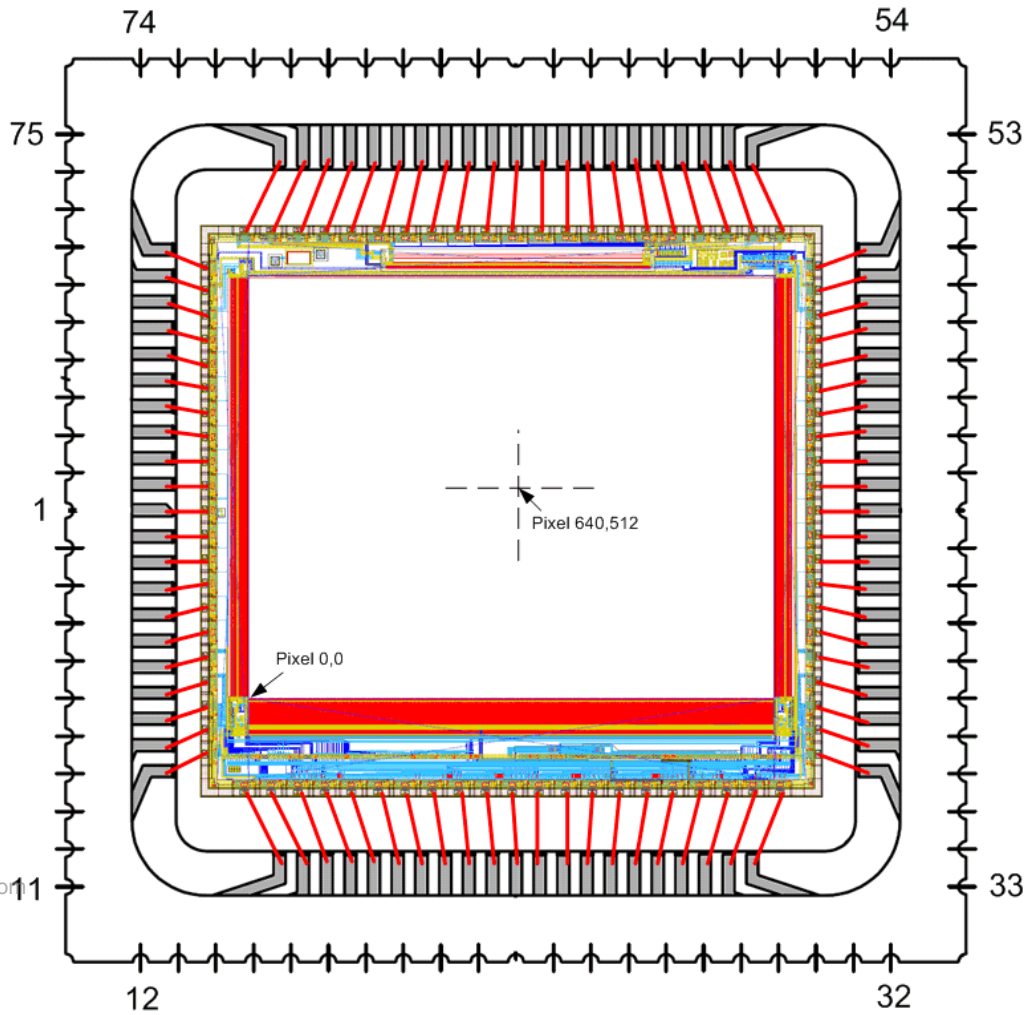
www.DataSheet4U.com



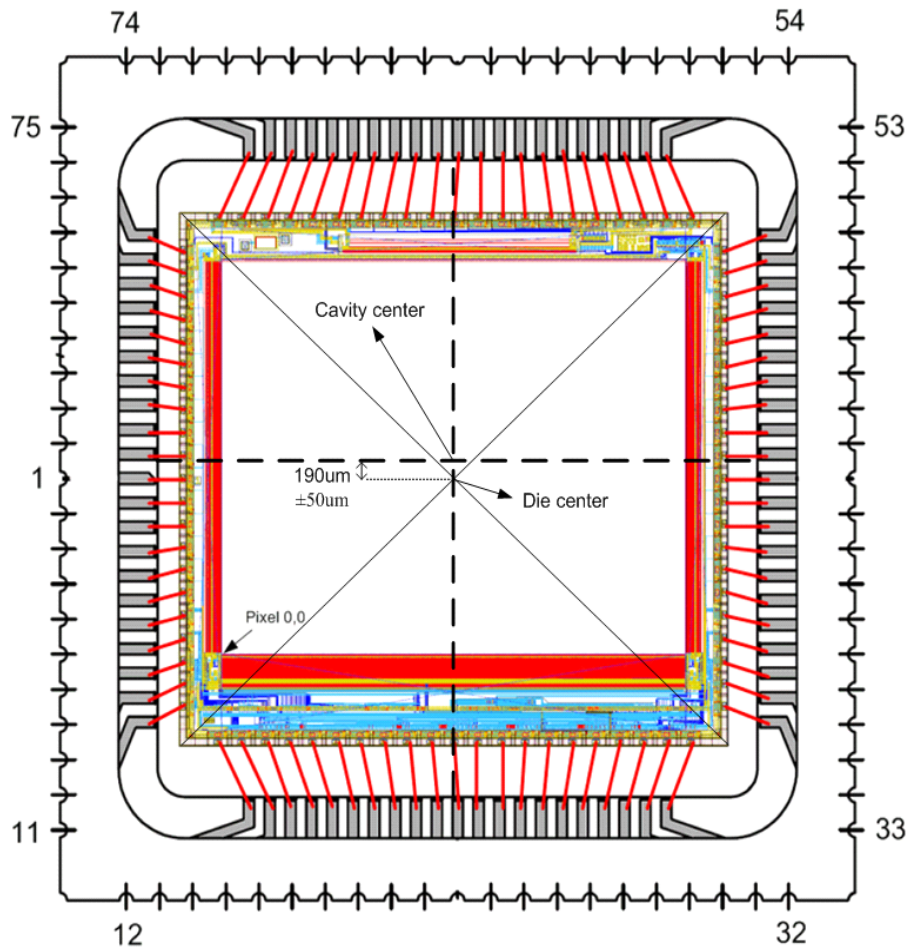


## Bonding of the IBIS5-B-1300 Sensor in the 84-Pin LCC Package

Figure 35. Bonding of the IBIS5-B-1300 in the 84-Pin LCC Package



www.DataSheet4U.com

*Die Placement of the IBIS5-B-1300 in the 84-Pin LCC Package***Figure 36. Die Placement of the IBIS5-B-1300 in the 84-Pin LCC Package**

www.DataSheet4U.com

Tolerance on the die placement in X- and Y-directions is maximal  $\pm 50 \mu\text{m}$ .

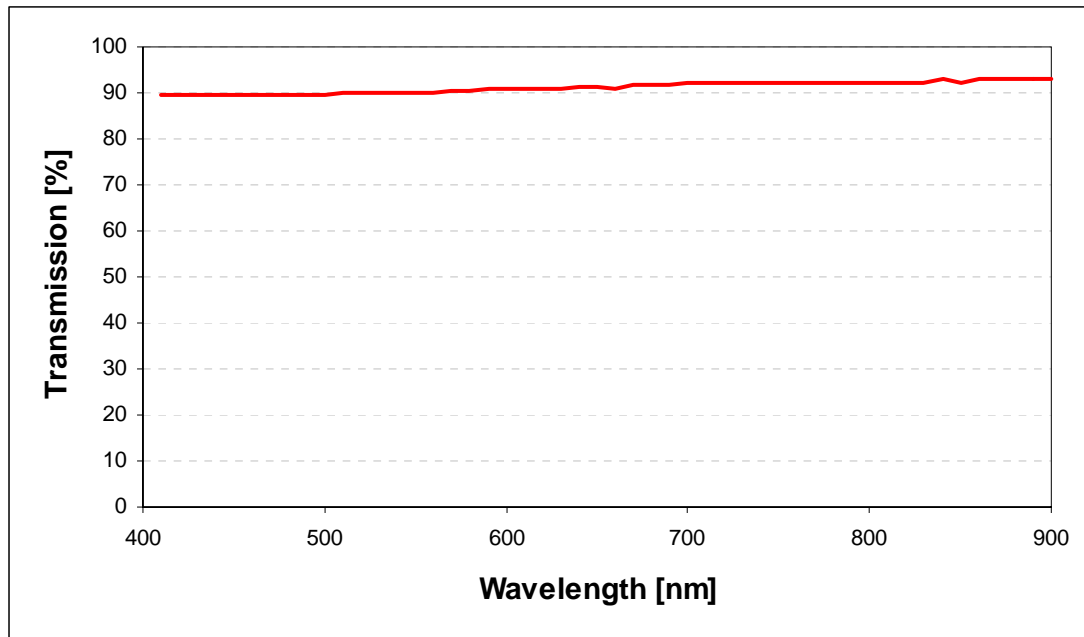


## IBIS5-B-1300 CYII5FM1300AB

### Cover Glass

A D263 glass lid (which has a refraction index of 1.52) is used as a protection glass lid on top of all IBIS5-B-1300 sensors. [Figure 37](#) shows the transmission characteristics of the D263 glass.

**Figure 37. Transmission Characteristics of the D263 Glass**





# IBIS5-B-1300 CYII5FM1300AB

## Storage and Handling

### Storage Conditions

Table 29. Storage Conditions

| Description | Minimum | Maximum | Units |
|-------------|---------|---------|-------|
| Temperature | -30     | +85     | °C    |

### Handling and Soldering Conditions

Take special care when soldering image sensors with color filter arrays (RGB color filters) onto a circuit board since color filters are sensitive to high temperatures. Prolonged heating at elevated temperatures can result in deterioration of the performance of the sensor. The following recommendations are made to ensure that sensor performance is not compromised during end-users' assembly processes.

#### Board Assembly

Place the device onto boards in accordance with strict ESD controls for Class 0, JESD22 Human Body Model, and Class A, JESD22 Machine Model devices. Assembly operators must always wear all designated and approved grounding equipment; use grounded wrist straps at ESD protected workstations including the ionized blowers. Use only ESD protected tools.

#### Manual Soldering

Observe the following conditions when using a soldering iron: Use a soldering iron with temperature control at the tip. The soldering iron tip temperature must not exceed 350°C. Make certain that the soldering period for each pin is less than five seconds.

#### Reflow Soldering

Figure 38 shows the maximum recommended thermal profile for a reflow soldering system. If the temperature/time profile exceeds these recommendations, damage to the image sensor can occur. See Figure 38 for more details.

### Precautions and Cleaning

Avoid spilling solder flux on the cover glass; bare glass and particularly glass with antireflection filters are adversely affected by the flux. Avoid mechanical or particulate damage to the cover glass. Use isopropyl alcohol (IPA) as a solvent for cleaning the image sensor glass lid. When using other solvents, make certain to confirmed beforehand whether or not the solvent can dissolve the package and/or the glass lid.

### X-ray inspection

X-ray inspection to check the solder leads of the image sensor is not recommended because the high energetic radiation can permanently damage the devices or cause image artefacts.

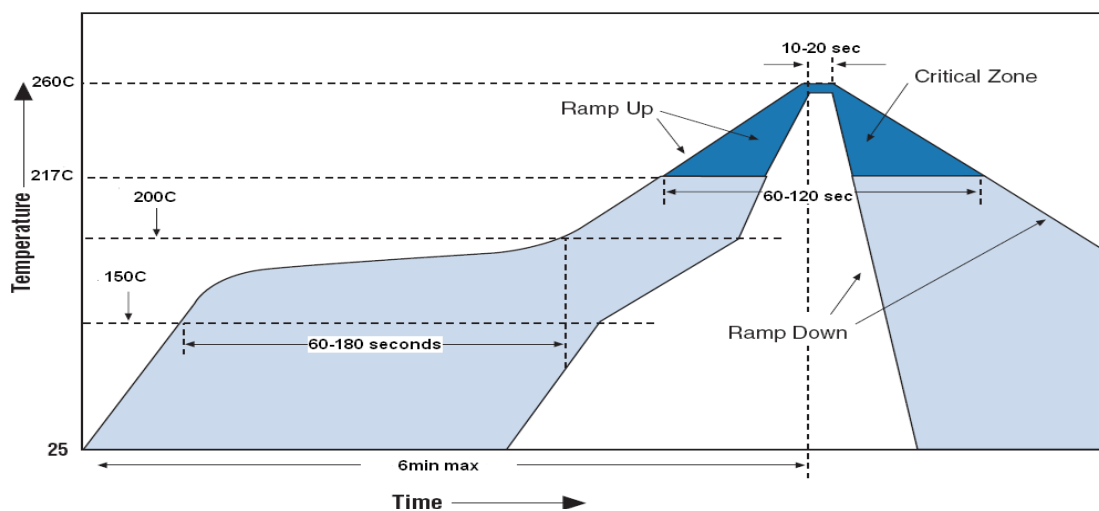
### RoHS (Pb-free) Compliance

This paragraph reports the use of hazardous chemical substances as required by the RoHS Directive (excluding packing material).

Table 30. The Chemical Substances and Information About Any Intentional Content

| Chemical Substance                    | Intentional content? | Where is the intentional content contained? |
|---------------------------------------|----------------------|---|
| Lead                                  | NO                   | -   |
| Cadmium                               | NO                   | -   |
| Mercury                               | NO                   | -   |
| Hexavalent Chromium                   | NO                   | -   |
| PBB (Polybrominated biphenyls)        | NO                   | -   |
| PBDE (Polybrominated diphenyl ethers) | NO                   | -   |

Figure 38. Reflow Soldering Temperature Profile





## IBIS5-B-1300 CYII5FM1300AB

### Information on Pb-Free Soldering:

IBIS5-B-1300-M2 (serial numbers beyond 3694): the product was tested successfully for Pb-free soldering processes, using a reflow temperature profile with maximum 260°C, minimum 40s at 255°C and minimum 90s at 217°C.

**Note** 'Intentional content' is defined as any material demanding special attention that is allowed into the product as follows:

1. A chemical composition is added into the inquired product intentionally in order to produce and maintain the required performance and function of the product.
2. A chemical composition which is used intentionally in the manufacturing process, that is allowed into the product.

### Ordering Information

| Cypress Part number | Package                       | Glass Lid <sup>[7]</sup> | Mono/Color |
|---------------------|-------------------------------|--------------------------|------------|
| CYII5SC1300AA-HSC   | 84-pin JLCC <sup>[6]</sup>    | Mono                     | Mono       |
| CYII5SC1300AB-HDC   | 84-pin JLCC <sup>[6]</sup>    | Mono                     | RGB Bayer  |
| CYII5SM1300AB-HDC   | 84-pin JLCC <sup>[6][8]</sup> | Mono                     | Mono       |
| CYII5SM1300AB-QDC   | 84-pin LCC                    | Mono                     | Mono       |
| CYII5SC1300AB-QDC   | 84-pin LCC                    | Mono                     | RGB Bayer  |
| CYIIFM1300AB-QDC    | 84-pin LCC                    | Mono                     | Mono       |

The following case is not treated as 'intentional content':

1. The above material is contained as an impurity into raw materials or parts of the intended product. The impurity is defined as a substance that cannot be removed industrially, or it is produced using a process such as chemical composing or reaction, and it cannot be removed technically.

### Notes

6. JLCC package for use in evaluation kits only.
7. D263 is used as protective cover glass lid (see [Figure 37](#) for spectral transmittance).
8. The CYII5FM1300AB has a thicker epitaxial Si layer for enhanced sensitivity in the NIR region. Other packaging combinations are available upon special request. Contact your local Cypress sales office for more information about part names, prices and availability.



## IBIS5-B-1300 CYII5FM1300AB

### Appendix A: IBIS5 Evaluation System

For evaluating purposes an IBIS5 evaluation kit is available.

The IBIS5 evaluation kit consists of a multifunctional digital board (memory, sequencer and IEEE 1394 Fire Wire interface) and an analog image sensor board.

Visual Basic software (under Win 2000™ or XP™) allows the grabbing and display of images and movies from the sensor. Store all acquired images and movies in different file formats (8 or 16-bit). You can adjust all setting on the fly to evaluate the sensors specifications. You can load default register values to start the software in a wanted state.

Figure 39. Content of the IBIS5 Evaluation Kit





## IBIS5-B-1300 CYII5FM1300AB

### Appendix B: IBIS5-1300 Revision Overview

Table 31. IBIS5-1300 Revision Differences

| Parameter              | IBIS5-1300   | IBIS5-A-1300                    | IBIS5-AE-1300                   | IBIS5-B-1300   |
|------------------------|--|---------------------------------|---------------------------------|--|
| Status                 | Obsolete   | Production                      | Production                      | Sampling   |
| QE * FF (peak)         | 0.13 A/W<br>(@ 650 nm)                                     | 0.16 A/W<br>(@ 650 nm)          | 0.21 A/W<br>(@ 760 nm)          | 0.16 A/W<br>(@ 650 nm)                                     |
| Full well charge       | 120.000 e-   | 62.500 e-                       | 62.500 e-                       | 62.500 e-  |
| Output signal swing    | 1V (unity gain)<br>1.8V (max.)                             | 1.1V (unity gain)<br>1.8V (max) | 1.1V (unity gain)<br>1.8V (max) | 1.1V (unity gain)<br>1.8V (max)                            |
| Conversion gain        | 12 $\mu\text{V}/\text{e}^-$                                | 17.6 $\mu\text{V}/\text{e}^-$   | 17.6 $\mu\text{V}/\text{e}^-$   | 17.6 $\mu\text{V}/\text{e}^-$                              |
| Temporal noise         | 85 e-  | 40 e-                           | 40 e-                           | 40 e-  |
| S/N ratio              | 1412:1 / 63 dB   | 1563:1 / 64 dB                  | 1563:1 / 64 dB                  | 1563:1 / 64 dB   |
| FPN                    | 0.34 (% of fw)   | 0.15 (% of fw)                  | 0.15 (% of fw)                  | 0.15 (% of fw)   |
| PRNU (at Qsat/2)       | < 10% (p-p)  | < 10% (p-p)                     | < 10% (p-p)                     | < 10% (p-p)  |
| Dark current (average) | 66 mV/s  | 7.22 mV/s                       | 7.22 mV/s                       | 7.22 mV/s  |
| Pixel output rate      | 40 MHz   | 40 MHz                          | 40 MHz                          | 40 MHz   |
| Frame rate             | 27.5 fps <sup>[9]</sup>                                    | 27.5 fps <sup>[9]</sup>         | 27.5 fps <sup>[9]</sup>         | 27.5 fps <sup>[9]</sup>                                    |
| Interface              | Serial 2-wire <sup>[10]</sup><br>Serial 3-wire<br>Parallel | Serial 3-wire<br>Parallel       | Serial 3-wire<br>Parallel       | Serial 2-wire <sup>[10]</sup><br>Serial 3-wire<br>Parallel |
| Extended dynamic range | Double/multiple slope                                      | Double/multiple slope           | Double/multiple slope           | Double/multiple slope                                      |
| Timing                 | See "Timing Diagrams"<br>on page 17                        | Identical                       | Identical                       | Identical  |
| Biasing:               |  |                                 |                                 |  |
| DEC_CMD                | 50 k $\Omega$  | 50 k $\Omega$                   | 50 k $\Omega$                   | 50 k $\Omega$  |
| DAC_VHIGH              | 5 k $\Omega$   | 0 $\Omega$                      | 0 $\Omega$                      | 0 $\Omega$   |
| DAC_VLOW               | 10 k $\Omega$  | 0 $\Omega$                      | 0 $\Omega$                      | 0 $\Omega$   |
| AMP_CMD                | 50 k $\Omega$  | 50 k $\Omega$                   | 50 k $\Omega$                   | 50 k $\Omega$  |
| COL_CMD                | 50 k $\Omega$  | 50 k $\Omega$                   | 50 k $\Omega$                   | 50 k $\Omega$  |
| PC_CMD                 | 25 k $\Omega$  | 25 k $\Omega$                   | 25 k $\Omega$                   | 25 k $\Omega$  |
| ADC_CMD                | 50 k $\Omega$  | 50 k $\Omega$                   | 50 k $\Omega$                   | 50 k $\Omega$  |
| ADC_VHIGH              | 130 $\Omega$   | 90 $\Omega$                     | 90 $\Omega$                     | 360 $\Omega$   |
| ADC_VLOW               | 240 $\Omega$   | 360 $\Omega$                    | 360 $\Omega$                    | 1200 $\Omega$  |

#### Notes

9. Rolling shutter mode (see also paragraph ).

10. The serial 2-wire interface is a write-only I2C-compatible interface.



## IBIS5-B-1300 CYII5FM1300AB

### Document History Page

| Document Title: IBIS5-B-1300 CYII5FM1300AB 1.3 MP CMOS Image Sensor<br>Document Number: 38-05710 |         |                 |   |
|--|---------|-----------------|---|
| REV.   | ECN NO. | Orig. of Change | Description of Change   |
| **   | 310213  | FVK             | New Data Sheet  |
| *A   | 649064  | FPW             | Ordering information update and new layout. Implemented the new template. Moved figure captions to the top of the figures and moved notes to the bottom of the page per new template. Verified all cross-referencing. Moved the specifications towards the back. Corrected one variable on the Master pages. Spelled checked. |
| *B   | 1162847 | FPW/ARI         | BGA package information removed. Implemented new template. Edited for template compliance.  |
| *C   | 1417584 | FPW             | Die placement drawing update  |

www.DataSheet4U.com

© Cypress Semiconductor Corporation, 2005-2007. The information contained herein is subject to change without notice. Cypress Semiconductor Corporation assumes no responsibility for the use of any circuitry other than circuitry embodied in a Cypress product. Nor does it convey or imply any license under patent or other rights. Cypress products are not warranted nor intended to be used for medical, life support, life saving, critical control or safety applications, unless pursuant to an express written agreement with Cypress. Furthermore, Cypress does not authorize its products for use as critical components in life-support systems where a malfunction or failure may reasonably be expected to result in significant injury to the user. The inclusion of Cypress products in life-support systems application implies that the manufacturer assumes all risk of such use and in doing so indemnifies Cypress against all charges.

Any Source Code (software and/or firmware) is owned by Cypress Semiconductor Corporation (Cypress) and is protected by and subject to worldwide patent protection (United States and foreign), United States copyright laws and international treaty provisions. Cypress hereby grants to licensee a personal, non-exclusive, non-transferable license to copy, use, modify, create derivative works of, and compile the Cypress Source Code and derivative works for the sole purpose of creating custom software and or firmware in support of licensee product to be used only in conjunction with a Cypress integrated circuit as specified in the applicable agreement. Any reproduction, modification, translation, compilation, or representation of this Source Code except as specified above is prohibited without the express written permission of Cypress.

Disclaimer: CYPRESS MAKES NO WARRANTY OF ANY KIND, EXPRESS OR IMPLIED, WITH REGARD TO THIS MATERIAL, INCLUDING, BUT NOT LIMITED TO, THE IMPLIED WARRANTIES OF MERCHANTABILITY AND FITNESS FOR A PARTICULAR PURPOSE. Cypress reserves the right to make changes without further notice to the materials described herein. Cypress does not assume any liability arising out of the application or use of any product or circuit described herein. Cypress does not authorize its products for use as critical components in life-support systems where a malfunction or failure may reasonably be expected to result in significant injury to the user. The inclusion of Cypress' product in a life-support systems application implies that the manufacturer assumes all risk of such use and in doing so indemnifies Cypress against all charges.

Use may be limited by and subject to the applicable Cypress software license agreement.

Document #: 38-05710 Rev. \*C

Revised August 27, 2007

Page 40 of 40

PSoC Designer™, Programmable System-on-Chip™, and PSoC Express™ are trademarks and PSoC® is a registered trademark of Cypress Semiconductor Corp. All other trademarks or registered trademarks referenced herein are property of the respective corporations. Purchase of I2C components from Cypress or one of its sublicensed Associated Companies conveys a license under the Philips I2C Patent Rights to use these components in an I2C system, provided that the system conforms to the I2C Standard Specification as defined by Philips. All products and company names mentioned in this document may be the trademarks of their respective holders.