



CYT1000B Specification

Specialty

- Output current is adjustable 5mA-60mA, constant current precision can reach $\pm 3\%$;
- With over temperature protection function;
- No EMC Question;
- Chip and PCB can share Aluminum plate;
- The circuit is simple, low cost;
- Packaging: T0252-2;

Summarize

CYT1000B is a linear constant current IC, the output current is adjustable, high precision of constant current, simple application solutions, cost and resistance capacity of step-down, over temperature protection function, safer and more reliable.

Pin figure

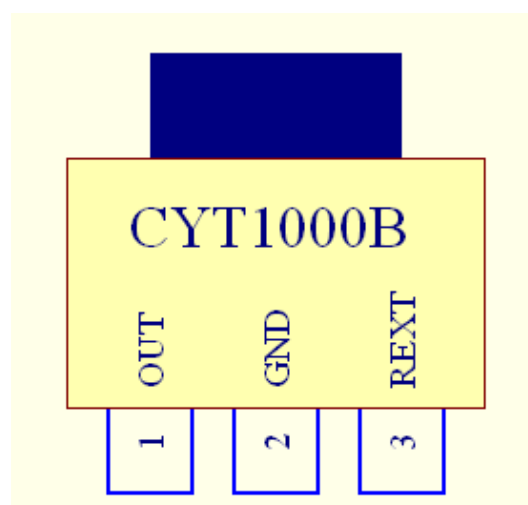

Application field

- Bulb light
- Tube light
- Downlight
- Ceiling light

Pin	Function
OUT	Current output port
GND	Chip land
REXT	Current regulation port

Typical application solutions

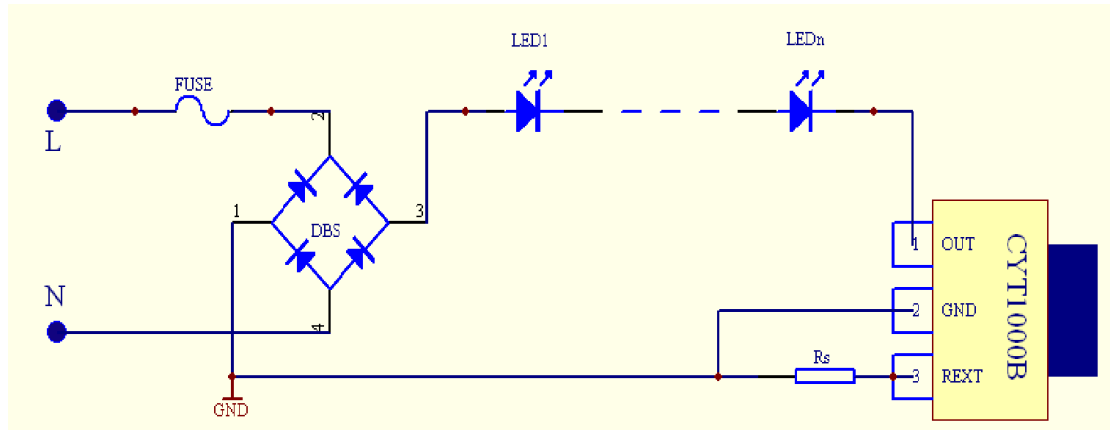

The limit parameter

If no special instructions, the environment temperature is 25°C

Characteristic parameters	Symbol	Range
The OUT port voltage	VOUT	-0.5~250V
The OUT port current	IOUT	5mA~60mA
Working temperature	TOPT	-40°C~+120°C
Storage temperature	TSTG	-50°C~+150°C
ESD stress	VESD	2KV

Electrical Working Parameters

If no special instructions, the environment temperature is 25°C

Parameters	Condition	Min	Typical value	Max	Unit
The OUT input voltage	Iout=30mA	6.5	-	-	V
The OUT port withstand voltage	Iout=0	250	-	-	V
Current output	-	5	-	60	mA
Quiescent current	Vout=10V REXT	-	0.16	0.25	mA
REXT Port voltage	Vout=10V	-	0.6	-	V
Iout error	I out=5~60mA		±3%		%
Temperature compensation point Tsc	-		110		°C



The out port output current characteristics

CYT1000B current output computational formula : $I_{out} = \frac{V_{rest}}{R_s} = \frac{600mV}{R_s} (mA)$

电流随电阻变化曲线

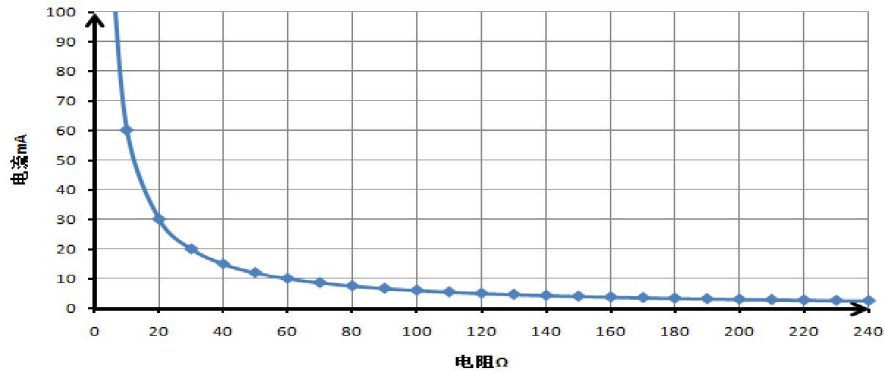

电流随端口电压变化曲线

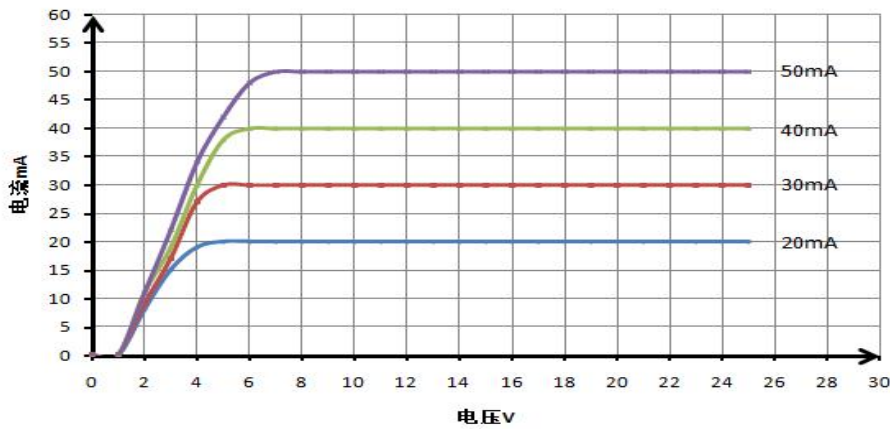

电流随结温变化曲线

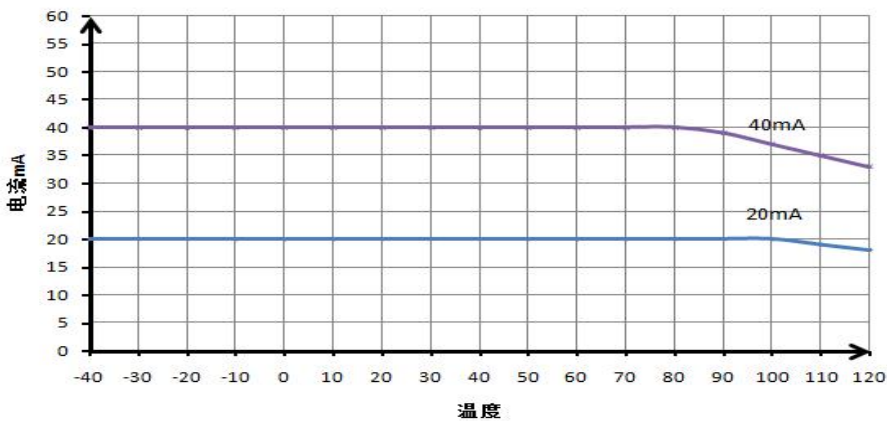



CYT1000B theoretical calculation

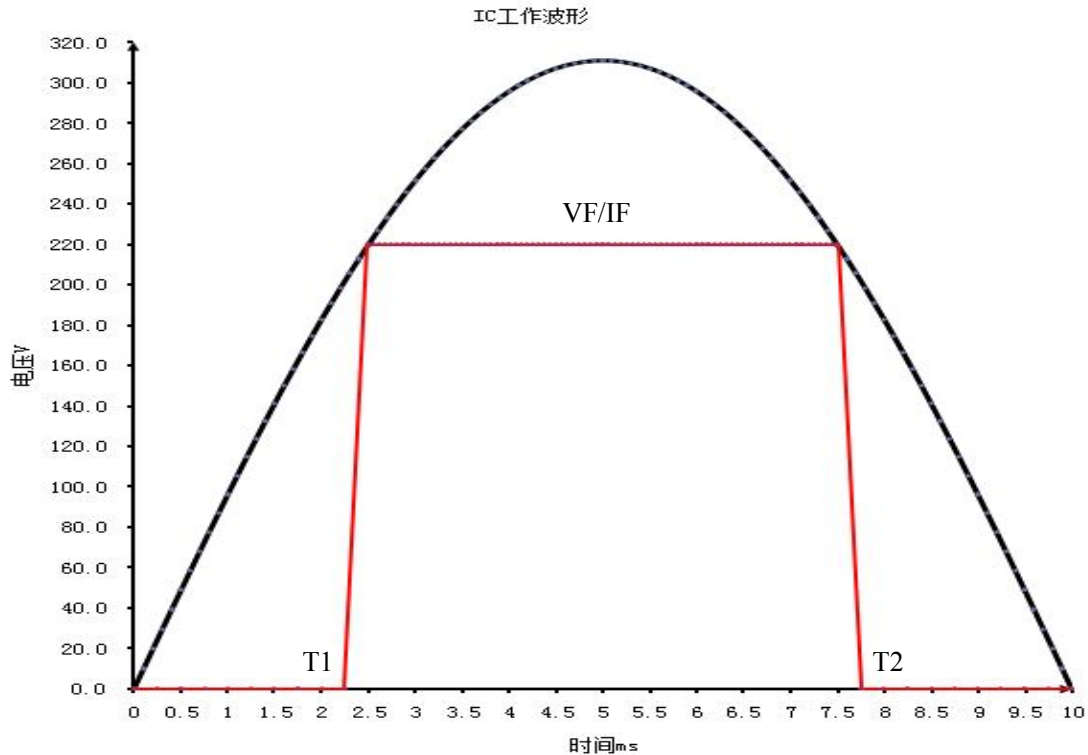

1、Mains of the wave function is a sine curve (picture 2) describe as follows:

$$u = \sqrt{2}U \sin(2\pi ft + \varphi) \quad (1)$$

Among: U: mains effective value, f: power frequency, φ : initial phase

The inverse operation of type 1 can be calculated:

$$T1 = \arcsin(V_F / \sqrt{2}U) / 2\pi f \quad (2)$$

$$T2 = 1/2f - \arcsin(V_F / \sqrt{2}U) / 2\pi f$$

This can work out the LED current conduction time:

$$\Delta T = T2 - T1 \quad (3)$$

2、V-I characteristic curve of lamp bead:

By type (2) it can be seen that a LED lamp bead voltage VF influence conduction time, affecting the effective current of the LED, as follows:

$$V_F = n * V_{LED} (I_{LED} = 600mA / R) \quad (4)$$

LED resistance R is different, the current is different, the rendered VF is



different, will affect the whole of the LED voltage VF

3、LED Power consumption calculation

The effective value of LED current calculation is as follows:

$$I_{LED} = I_F * \sqrt{\Delta T / T} \quad (5)$$

The effective value of LED voltage:

$$V_{LED} = V_F * \sqrt{\Delta T / T} \quad (6)$$

LED power consumption calculation is as follows:

$$P_{LED} = V_{LED} * I_{LED} = I_F * V_F * (\Delta T / T) \quad (7)$$

4、IC Power consumption calculation

Mains voltage and lamp bead voltage difference is the working voltage of IC, the expression is as follows:

$$u_{IC}(t) = u(t) - V(t) = \sqrt{2}U\sin(2\pi ft) - V(t) \quad (8)$$

IC power consumption is on the integral calculation, as follows:

$$P_{IC} = \int_{T1}^{T2} (\sqrt{2}U\sin(2\pi ft) - V_F) * I_F dt / T \quad (9)$$

5、Power efficiency calculation

$$\eta = P_{LED} / (P_{LED} + P_{IC} + P_{固有损耗})\% \quad (10)$$

Lines of the inherent loss refers to the switching loss of IC, line loss, the wastage of the rectifier bridge and other related loss these values cannot be calculated, but by contrast experiment we can conclude that the depletion approximation is a fixed value.

At this point, all the theoretical calculation about CYT1000B IC has been completed, can make the graphical user interface to the above formula, which can simulate the photovoltaic module in different lamp bead amount, different feedback resistance, under the condition of different types of lamp bead the change of the power and power efficiency, reference <CYT1000B application



design form>.

Application solutions instance

1、The PF value of 0.5 90% efficiency without stroboscopic scheme

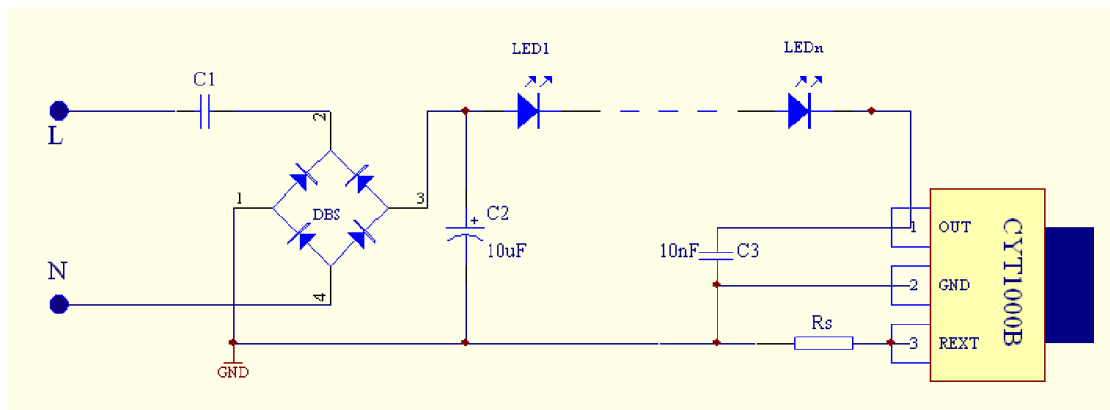

In the scenario above:

When LED series voltage of 270-285v, can do not need to buck capacitor C1, when the LED lamp bead amount is small, by choosing appropriate capacitance and regulate the flow of constant value, can achieve the best power efficiency, suitable for 3-5 w light source module;

Capacitance C2 can for power supply filter, improve the average of the power supply voltage, so as to improve the efficiency of power supply, but only about 0.5 PF value of the whole machine;

Capacitor C3 main anti surge buffer effect, avoid IC moment is punctured, improve product reliability;

Resistance RS can be used to adjust the LED constant current value, specific see IC output current were calculated

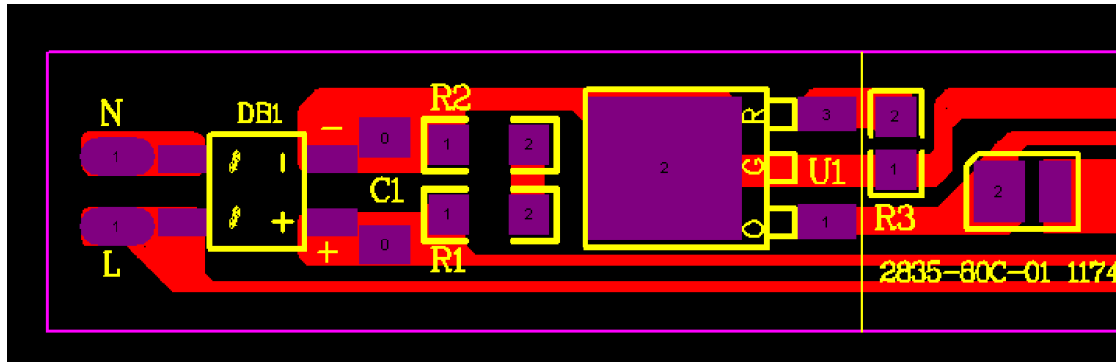

Integration of T8 fluorescent lamp scheme (0.5 90% efficiency without stroboscopic PF)

2,PF value of 0.9 80% efficiency low cost solution

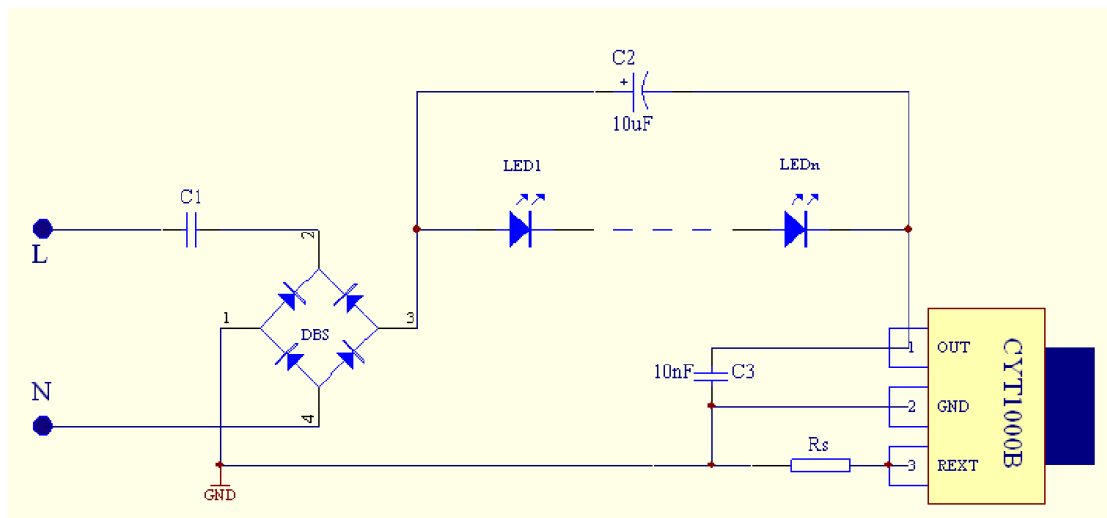

In the scenario above:

Input voltage is AC220V LED series voltage control between 220-240v, low voltage LED lamp string increases IC loss, reduce the power conversion efficiency. This plan line PF value around 0.9;When the LED lamp bead amount is small, by choosing the appropriate value of capacitance step-down and adjusting the constant current value, can achieve the best power efficiency and PF value, suitable for 3-5 w light source module;

Capacitance C2 to filter the light bead on both ends of the voltage, solve



the problem of stroboscopic, the PF value and power, increase the capacitance can improve the power conversion efficiency by about 5%; Capacitor C3 main anti surge buffer effect, avoid IC moment is punctured, improve product reliability;

Resistance RS can be used to adjust the LED constant current value, specific see IC output current were calculated

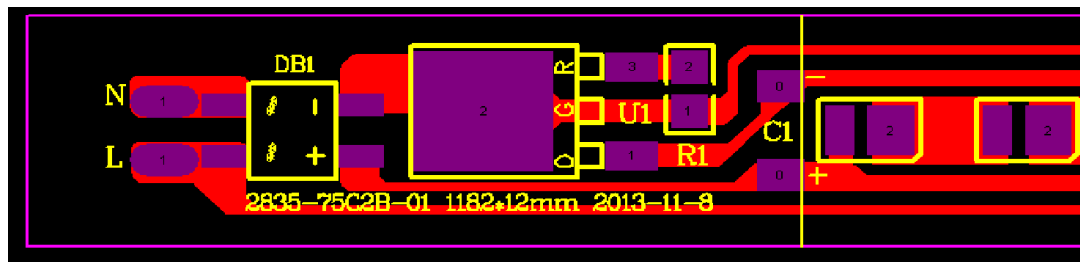

Integration of T8 fluorescent lamp scheme (0.5 90% efficiency without stroboscopic PF)

3,ic extension application solutions

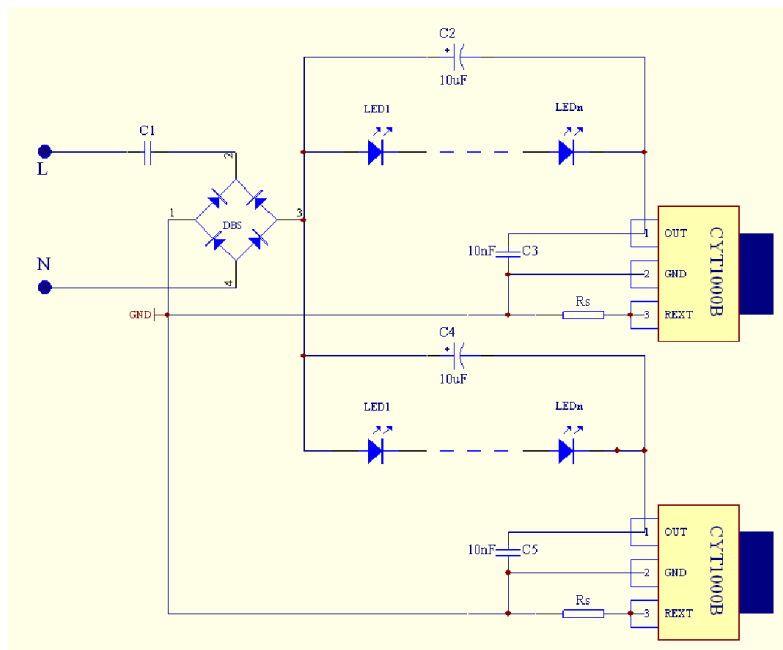

IC control LED, respectively

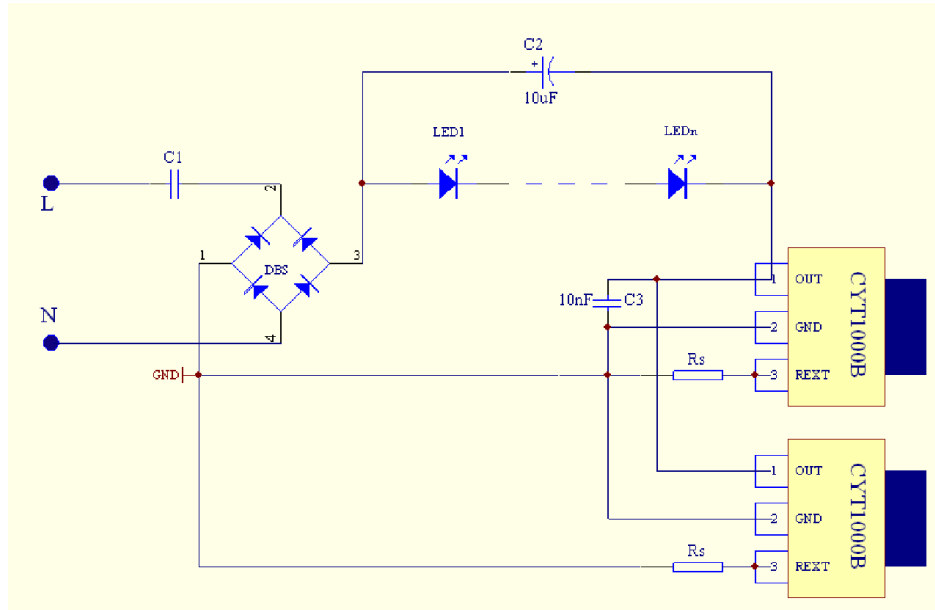

Parallel ICs control LEDs

Packaging form

TO252-2

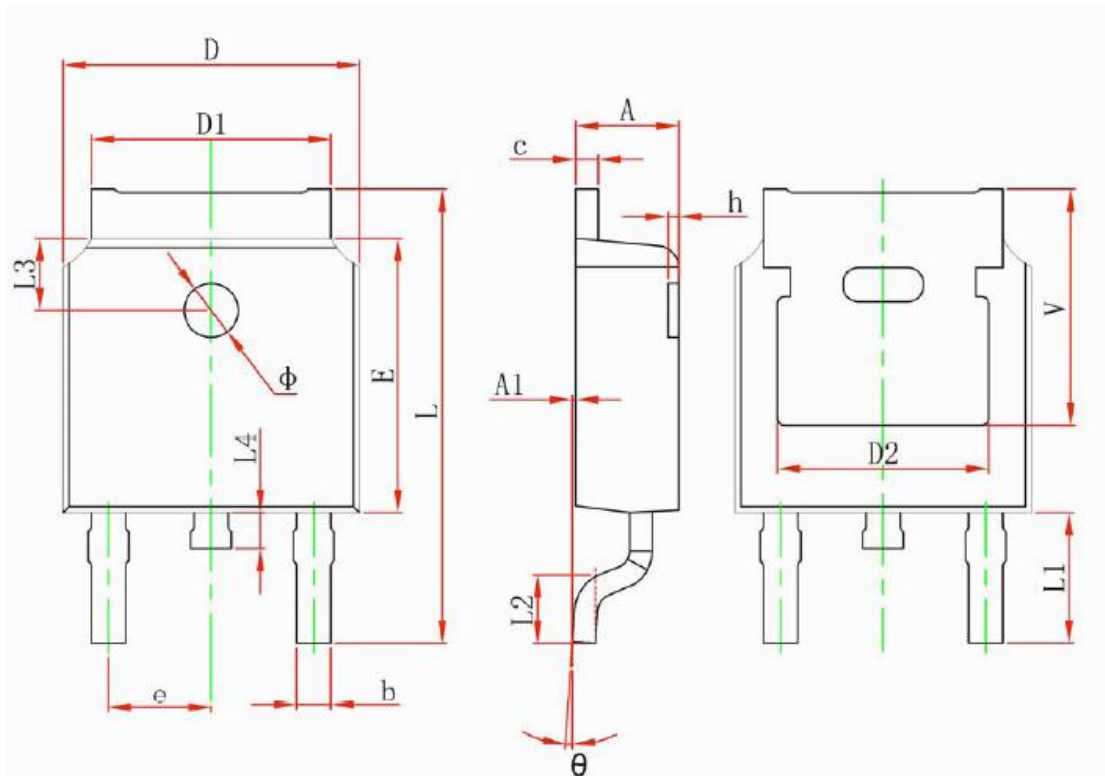



Symbol	Dimensions In Millimeters		Dimensions In Inches	
	Min.	Max.	Min.	Max.
A	2.200	2.400	0.087	0.094
A1	0.000	0.127	0.000	0.005
b	0.660	0.860	0.026	0.034
c	0.460	0.580	0.018	0.023
D	6.500	6.700	0.256	0.264
D1	5.100	5.460	0.201	0.215
D2	4.830 REF.		0.190 REF.	
E	6.000	6.200	0.236	0.244
e	2.186	2.386	0.086	0.094
L	9.800	10.400	0.386	0.409
L1	2.900 REF.		0.114 REF.	
L2	1.400	1.700	0.055	0.067
L3	1.600 REF.		0.063 REF.	
L4	0.600	1.000	0.024	0.039
Φ	1.100	1.300	0.043	0.051
θ	0°	8°	0°	8°
h	0.000	0.300	0.000	0.012
V	5.350 REF.		0.211 REF.	