

SD2™ USB and Mass Storage Peripheral Controller

Features

- Latest-generation storage support
 - SD2.0/SDXC – UHS1 SDR50 / DDR50 Master
 - eMMC 4.4 Master
 - SDIO 3.0 Master
- USB integration
 - Certified USB 2.0 peripheral: Hi-Speed (HS) and Full-Speed (FS) only
 - Thirty-two physical endpoints
 - Integrated transceiver
- Ultra low-power in core power-down mode
 - Less than 60 μ A with VBATT on and 20 μ A with VBATT off
- I²C master controller at 1 MHz
- Selectable input clock frequencies
 - 19.2, 26, 38.4, and 52 MHz

- 19.2-MHz crystal input support
- Independent power domains for core and I/O
- 10 × 10 mm, 0.8-mm pitch ball grid array (BGA) package

Applications

- USB thumb drives
- Card readers
- Laptop with SD slots
- SD slot in TV/STB
- WiFi Dongles
- USB SDIO Bridge

Logic Block Diagram

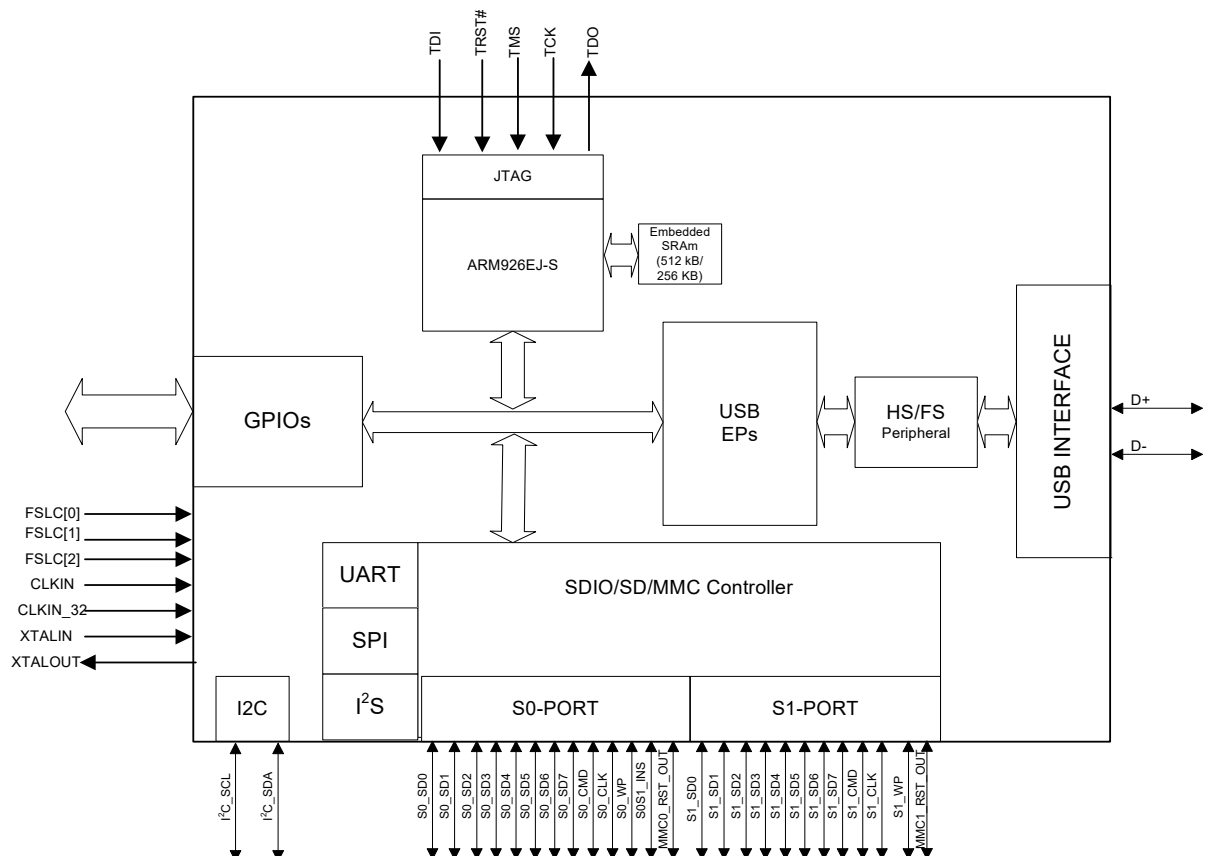

Contents

Functional Overview	3	Absolute Maximum Ratings	21
USB Interface (U-Port)	3	Operating Conditions	21
Mass-Storage Support (S-Port)	3	DC Specifications	21
I2C Interface	3	Thermal Characteristics	22
UART Interface	3	Reset Sequence	23
I2S Interface	3	Package Diagram	24
SPI Interface	3	Ordering Information	25
Boot Options	4	Ordering Code Definitions	25
Reset	4	Acronyms	26
Clocking	4	Document Conventions	26
32-kHz Watchdog Timer Clock Input	4	Units of Measure	26
Power	5	Errata	27
Power Modes	5	Qualification Status	27
Configuration Fuse	8	Errata Summary	27
Digital I/Os	8	Document History Page	29
EMI	8	Sales, Solutions, and Legal Information	30
System Level ESD	8	Worldwide Sales and Design Support	30
Pinouts	8	Products	30
Pin Descriptions	9	PSoC® Solutions	30
AC Timing Parameters	13	Cypress Developer Community	30
Storage Port Timing	13	Technical Support	30
I2C Interface Timing	16		

Functional Overview

SD2™ is a USB 2.0 High Speed mass-storage controller providing the latest SD/MMC support. SD2 complies with the SD Specification, Version 3.0, and the MMC Specification, Version 4.41.

SD2 offers the following access paths among USB and mass storage ports:

- A USB-port (U-Port) supporting USB 2.0 peripheral
- Two mass-storage ports (S0-Port and S1-Port) supporting mass-storage devices. Following are the possible configurations for the two mass-storage ports:
 - SD and MMC
 - SD and SD
 - MMC and MMC
 - SD and SDIO
 - MMC and SDIO
 - SDIO and SDIO

Combinations of these accesses can happen independently or in an interleaved manner.

The SD2 complies with the USB 2.0 specification.

USB Interface (U-Port)

SD2 offers the following features:

- Supports USB peripheral functionality compliant with the USB 2.0 Specification
- Supports up to 16 IN and 16 OUT endpoints.
- Supports the USB 2.0 Streams feature. It also supports USB Attached SCSI (UAS) device class to optimize mass-storage access performance.
- As a USB peripheral, SD2 supports UAS and Mass Storage Class (MSC) peripheral classes.
- When the USB port is not in use, the PHY and transceiver may be disabled for power savings.

Figure 1. USB Interface Signals

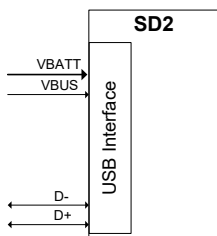

Mass-Storage Support (S-Port)

The SD2 storage interface port supports the following specifications:

- SD Specification, Version 3.0
- Multimedia Card-System Specification, MMCA Technical Committee, Version 4.4
- SDIO Host controller compliant with SDIO Specification Version 3.00

I²C Interface

SD2 has an I²C interface compatible with the I²C Bus Specification Revision 3. Because SD2's I²C interface is capable of operating only as an I²C master, it may be used to communicate with other I²C slave devices. For example, SD2 may boot from an EEPROM connected to the I²C interface, as a selectable boot option.

SD2's I²C master controller also supports multi-master mode functionality.

The power supply for the I²C interface is VIO5, which is a separate power domain from the other serial peripherals. This is to allow the I²C interface the flexibility to operate at a different voltage than the other serial interfaces.

The I²C controller supports bus frequencies of 100 kHz, 400 kHz, and 1 MHz. When VIO5 is 1.2 V, the maximum operating frequency supported is 100 kHz. When VIO5 is 1.8 V, 2.5 V, or 3.3 V, the operating frequencies supported are 400 kHz and 1 MHz. The I²C controller supports the clock stretching feature to enable slower devices to exercise flow control.

Both SCL and SDA signals of the I²C interface require external pull-up resistors. These resistors must be connected to VIO5.

UART Interface

The UART interface of SD2 supports full-duplex communication. It includes the signals noted in Table 1.

Table 1. UART Interface Signals

Signal	Description
TX	Output signal
RX	Input signal
CTS	Flow control
RTS	Flow control

The UART is capable of generating a range of baud rates, from 300 bps to 4608 Kbps, selectable by the firmware. If flow control is enabled, then SD2's UART only transmits data when the CTS input is asserted. In addition to this, SD2's UART asserts the RTS output signal, when it is ready to receive data.

I²S Interface

SD2 has an I²S port to support external audio codec devices. SD2 functions as I²S Master as transmitter only. The I²S interface consists of four signals: clock line (I2S_CLK), serial data line (I2S_SD), word select line (I2S_WS), and master system clock (I2S_MCLK). SD2 can generate the system clock as an output on I2S_MCLK or accept an external system clock input on I2S_MCLK.

The sampling frequencies supported by the I²S interface are 8 kHz, 16 kHz, 32 kHz, 44.1 kHz, 48 kHz, 96 kHz and 192 kHz.

SPI Interface

SD2 supports an SPI Master interface on the Serial Peripherals port. The maximum operation frequency is 33 MHz.

The SPI controller supports four modes of SPI communication (see SPI Timing Specification on page 19 for details on the modes) with the Start-Stop clock. This controller is a

single-master controller with a single automated SSN control. It supports transaction sizes ranging from 4 bits to 32 bits.

Boot Options

SD2 can load boot images from various sources, selected by the configuration of the PMODE pins. The boot options for the SD2 are as follows:

- Boot from USB
- Boot from I²C
- Boot from eMMC on S0-Port
- Boot from SPI
 - Cypress SPI Flash parts supported are S25FS064S (64-Mbit), S25FS128S (128-Mbit) and S25FL064L (64-Mbit).
 - Winbond W25Q32FW (32-Mbit) is also supported.

Table 2. Booting Options for SD2

PMODE[2:0] ^[1]	Boot From
FF0	S0-Port: eMMC On failure, USB boot enabled
FF1	USB Boot
FFF	I ² C On Failure, USB Boot is enabled
0FF	I ² C only
0F1	SPI On Failure, USB Boot is enabled

Reset

A reset is initiated by asserting the Reset# pin on SD2. The specific reset sequence and timing requirements are detailed in [Figure 3](#) on page 16 and [Table 14](#) on page 23. All I/Os are tristated during a hard reset.

Clocking

SD2 allows either a crystal to be connected between the XTALIN and XTALOUT pins or an external clock to be connected at the CLKIN pin. The XTALIN, XTALOUT, CLKIN, and CLKIN_32 pins can be left unconnected if not used.

Crystal frequency supported is 19.2 MHz, while the external clock frequencies supported are 19.2, 26, 38.4, and 52 MHz.

SD2 has an on-chip oscillator circuit that uses an external 19.2 MHz (± 100 ppm) crystal (when the crystal option is used). An appropriate load capacitance is required with a crystal. Refer to the specification of the crystal used to determine the appropriate load capacitance. The FSLC[2:0] pins must be configured appropriately to select the crystal option/clock frequency option. The configuration options are shown in [Table 3](#).

Clock inputs to SD2 must meet the phase noise and jitter requirements specified in [Table 4](#).

Note

1. F indicates Floating.

The input clock frequency is independent of the clock/data rate of SD2 core or any of the device interfaces. The internal PLL applies the appropriate clock multiply option depending on the input frequency.

Table 3. Crystal/Clock Frequency Selection

FSLC[2]	FSLC[1]	FSLC[0]	Crystal/Clock Frequency
0	0	0	19.2-MHz crystal
1	0	0	19.2-MHz input CLK
1	0	1	26-MHz input CLK
1	1	0	38.4-MHz input CLK
1	1	1	52-MHz input CLK

Table 4. Input Clock Specifications for SD2

Parameter	Description	Specification		Units
		Min	Max	
Phase noise	100-Hz offset	–	–75	dB
	1-kHz offset	–	–104	dB
	10-kHz offset	–	–120	dB
	100-kHz offset	–	–128	dB
	1-MHz offset	–	–130	dB
Maximum frequency deviation		–	150	ppm
Duty cycle		30	70	%
Overshoot		–	3	%
Undershoot		–	–3	%
Rise time/fall time		–	3	ns

32-kHz Watchdog Timer Clock Input

SD2 includes a watchdog timer that can be used to interrupt the core, automatically wake up SD2 in Standby mode, and reset the core. The watchdog timer runs off a 32-kHz clock, which may optionally be supplied from an external source on a dedicated pin of SD2.

The watchdog timer can be disabled by firmware.

Requirements for the optional 32-kHz clock input are listed in [Table 4](#).

Table 5. 32-kHz Clock Input Requirements

Parameter	Min	Max	Units
Duty cycle	40	60	%
Frequency deviation	–	± 200	ppm
Rise Time/fall Time	–	200	ns

Power

SD2 has the following main groups of power supply domains:

- **IO_VDDQ:** This refers to a group of independent supply domains for digital I/Os. The voltage level on these supplies are 1.8 V to 3.3 V. SD2 provides six independent supply domains for digital I/Os listed as follows:
 - VIO2: S0-Port (for SD/MMC) I/O Power Supply Domain
 - VIO3: S1-Port (for SD/MMC) I/O Power Supply Domain
 - VIO1: S2-Port (GPIO) Power Supply Domain
 - VIO4: S1-Port GPIO[53:57] I/O Power Supply Domain (these pins support MMC's high nibble data line - D[7:4] on S1-Port)
 - VIO5: I2C Power Supply Domain (supports 1.2 V to 3.3 V)
 - CVDDQ: Clock Power Supply Domain
- **VDD:** This is the supply voltage for the logic core. The nominal supply voltage level is 1.2 V. This supplies the core logic circuits. The same supply must also be used for the following:
 - **AVDD:** This is the 1.2-V supply for the PLL, crystal oscillator and other core analog circuits
- **VBATT/VBUS:** This is the 3.2-V to 6-V battery power supply for the USB I/O and analog circuits. This supply powers the USB transceiver through SD2's internal voltage regulator. VBATT is internally regulated to 3.3 V.

Note: No specific power-up sequence for SD2 power domains. Minimum power on reset time of 1msec should be met and the power domains must be stable for SD2 operation.

Power Modes

SD2 supports the following power modes:

- **Normal mode:** This is the full-functional operating mode. In this mode the internal CPU clock and the internal PLLs are enabled. Normal operating power consumption does not exceed the sum of ICC_CORE max and ICC_USB max (see [Table 12](#) on page 21 for current consumption specifications). The I/O power supplies (VIO2, VIO3, VIO4, and VIO5) may be turned off when the corresponding interface is not in use. S2VDDQ cannot be turned off at any time if the S2-Port is used in the application.
- SD2 supports four low-power modes (see [Table 6](#) on page 5):
 - Suspend mode with USB 2.0 PHY enabled (L1 mode)
 - Suspend mode with USB 2.0 PHY disabled (L2 mode)
 - Standby mode (L3 mode)
 - Core power-down mode (L4 mode)

Table 6. Entry and Exit Methods for Low-Power Modes

Low Power Mode	Characteristics	Methods of Entry	Methods of Exit
Suspend mode with USB 2.0 PHY Enabled (L1 mode)	<ul style="list-style-type: none"> ■ The power consumption in this mode does not exceed ISB₁ ■ USB 2.0 PHY is enabled and is in U3 mode (one of the suspend modes defined by the USB 3.0 specification). This one block alone operates with its internal clock while all other clocks are shut down ■ All I/Os maintain their previous state ■ Power supply for the wakeup source and core power must be retained. All other power domains can be turned on/off individually ■ The states of the configuration registers, buffer memory and all internal RAM are maintained ■ All transactions must be completed before SD2 enters Suspend mode (state of outstanding transactions are not preserved) ■ The firmware resumes operation from where it was suspended (except when woken up by RESET# assertion) because the program counter does not reset 	<ul style="list-style-type: none"> ■ Firmware executing on the core can put SD2 into suspend mode. For example, on USB suspend condition, firmware may decide to put SD2 into suspend mode 	<ul style="list-style-type: none"> ■ D+ transitioning to low or high ■ D- transitioning to low or high ■ Detection of VBUS ■ Assertion of GPIO[17] ■ Assertion of RESET#

Table 6. Entry and Exit Methods for Low-Power Modes (continued)

Low Power Mode	Characteristics	Methods of Entry	Methods of Exit
Suspend mode with USB 2.0 PHY disabled (L2 mode)	<ul style="list-style-type: none"> ■ The power consumption in this mode does not exceed ISB_2 ■ USB 2.0 PHY is disabled and the USB interface is in suspend mode ■ The clocks are shut off. The PLLs are disabled ■ All I/Os maintain their previous state ■ USB interface maintains the previous state ■ Power supply for the wakeup source and core power must be retained. All other power domains can be turned on/off individually ■ The states of the configuration registers, buffer memory, and all internal RAM are maintained ■ All transactions must be completed before SD2 enters Suspend mode (state of outstanding transactions are not preserved) ■ The firmware resumes operation from where it was suspended (except when woken up by RESET# assertion) because the program counter does not reset 	<ul style="list-style-type: none"> ■ Firmware executing on the core can put SD2 into suspend mode. For example, on USB suspend condition, firmware may decide to put SD2 into suspend mode 	<ul style="list-style-type: none"> ■ D+ transitioning to low or high ■ D- transitioning to low or high ■ Detection of VBUS ■ Assertion of GPIO[17] ■ Assertion of RESET#

Table 6. Entry and Exit Methods for Low-Power Modes (continued)

Low Power Mode	Characteristics	Methods of Entry	Methods of Exit
Standby Mode (L3 mode)	<ul style="list-style-type: none"> ■ The power consumption in this mode does not exceed ISB₃ ■ All configuration register settings and program/data RAM contents are preserved. However, data in the buffers or other parts of the data path, if any, is not guaranteed. Therefore, the external processor should take care that needed data is read before putting SD2 into this Standby Mode ■ The program counter is reset after waking up from Standby ■ GPIO pins maintain their configuration ■ Crystal oscillator is turned off ■ Internal PLL is turned off ■ USB transceiver is turned off ■ Core is powered down. Upon wakeup, the core re-starts and runs the program stored in the program/data RAM ■ Power supply for the wakeup source and core power must be retained. All other power domains can be turned on/off individually 	<ul style="list-style-type: none"> ■ Firmware executing on the core or external processor configures the appropriate register 	<ul style="list-style-type: none"> ■ Detection of VBUS ■ Assertion of GPIO[17] ■ Assertion of RESET#
Core Power Down Mode (L4 mode)	<ul style="list-style-type: none"> ■ The power consumption in this mode does not exceed ISB₄ ■ Core power is turned off ■ All buffer memory, configuration registers and the program RAM do not maintain state. It is necessary to reload the firmware on exiting from this mode ■ In this mode, all other power domains can be turned on/off individually 	<ul style="list-style-type: none"> ■ Turn off VDD 	<ul style="list-style-type: none"> ■ Reapply VDD ■ Assertion of RESET#

Configuration Fuse

Fuse options are available for specific usage models. Contact Cypress Applications/Marketing for details.

Digital I/Os

SD2 provides firmware controlled pull-up or pull-down resistors internally on all digital I/O pins. The pins can be pulled high through an internal 50-kΩ resistor or can be pulled low through an internal 10-kΩ resistor to prevent the pins from floating. The I/O pins may have the following states:

- Tristated (High-Z)
- Weak pull-up (through internal 50 kΩ)
- Pull down (through internal 10 kΩ)
- Hold (I/O hold its value) when in low power modes

All unused I/Os should be pulled high by using the internal pull-up resistors. All unused outputs should be left floating. All I/Os can be driven at full-strength, three-quarter strength, half-strength, or quarter-strength. These drive strengths are configured based on each interface.

Pinouts

EMI

SD2 meets EMI requirements outlined by FCC 15B (USA) and EN55022 (Europe) for consumer electronics. SD2 can tolerate reasonable EMI, conducted by aggressor, outlined by these specifications and continue to function as expected.

System Level ESD

SD2 has built-in ESD protection on the D+, D-, GND pins on the USB interface. The ESD protection levels provided on these ports are:

- ±2.2-KV human body model (HBM) based on JESD22-A114 Specification
- ±6-KV contact discharge and ±8-KV air gap discharge based on IEC61000-4-2 level 3A
- ±8-KV contact discharge and ±15-KV air gap discharge based on IEC61000-4-2 level 4C.

This protection ensures the device continues to function after ESD events up to the levels stated.

The S0/S1_INS have up to ±2.2 KV HBM internal ESD protection.

Figure 2. SD2 BGA Ball Map (Top View)

	1	2	3	4	5	6	7	8	9	10	11
A	U3VSSQ	VDD	NC	NC	NC	NC	AVDD	VSS	DP	DM	NC
B	VIO4	FSLC[0]	NC	FSLC[1]	VDD	CVDDQ	AVSS	VSS	VSS	VDD	TRST#
C	GPIO[54]	GPIO[55]	VDD	GPIO[57]	RESET#	XTALIN	XTALOUT	R_USB2	OTG_ID	TDO	VIO5
D	GPIO[50]	GPIO[51]	GPIO[52]	GPIO[53]	GPIO[56]	CLKIN_32	CLKIN	VSS	I2C_GPIO[58]	I2C_GPIO[59]	NC
E	GPIO[47]	VSS	S1VDDQ	GPIO[49]	GPIO[48]	FSLC[2]	TDI	TMS	VDD	VBATT	VBUS
F	S0VDDQ	GPIO[45]	GPIO[44]	GPIO[41]	GPIO[46]	TCK	GPIO[2]	GPIO[5]	GPIO[1]	GPIO[0]	VDD
G	VSS	GPIO[42]	GPIO[43]	GPIO[30]	GPIO[25]	GPIO[22]	GPIO[21]	GPIO[15]	GPIO[4]	GPIO[3]	VSS
H	VDD	GPIO[39]	GPIO[40]	GPIO[31]	GPIO[29]	GPIO[26]	GPIO[20]	GPIO[24]	GPIO[7]	GPIO[6]	S2VDDQ
J	GPIO[38]	GPIO[36]	GPIO[37]	GPIO[34]	GPIO[28]	GPIO[16]	GPIO[19]	GPIO[14]	GPIO[9]	GPIO[8]	VDD
K	GPIO[35]	GPIO[33]	VSS	VSS	GPIO[27]	GPIO[23]	GPIO[18]	GPIO[17]	GPIO[13]	GPIO[12]	GPIO[10]
L	VSS	VSS	VSS	GPIO[32]	VDD	VSS	VDD	NC	S2VDDQ	GPIO[11]	VSS

Pin Descriptions

Table 7. Pin List

Pin No.	Power Domain	I/O	Name	Description		
S2-PORT (GPIO)						
F10	VI01	I/O	GPIO[0]	GPIO		
F9	VI01	I/O	GPIO[1]	GPIO		
F7	VI01	I/O	GPIO[2]	GPIO		
G10	VI01	I/O	GPIO[3]	GPIO		
G9	VI01	I/O	GPIO[4]	GPIO		
F8	VI01	I/O	GPIO[5]	GPIO		
H10	VI01	I/O	GPIO[6]	GPIO		
H9	VI01	I/O	GPIO[7]	GPIO		
J10	VI01	I/O	GPIO[8]	GPIO		
J9	VI01	I/O	GPIO[9]	GPIO		
K11	VI01	I/O	GPIO[10]	GPIO		
L10	VI01	I/O	GPIO[11]	GPIO		
K10	VI01	I/O	GPIO[12]	GPIO		
K9	VI01	I/O	GPIO[13]	GPIO		
J8	VI01	I/O	GPIO[14]	GPIO		
G8	VI01	I/O	GPIO[15]	GPIO		
J6	VI01	I/O	GPIO[16]	GPIO		
K8	VI01	I/O	GPIO[17]	GPIO		
K7	VI01	I/O	GPIO[18]	GPIO		
J7	VI01	I/O	GPIO[19]	GPIO		
H7	VI01	I/O	GPIO[20]	GPIO		
G7	VI01	I/O	GPIO[21]	GPIO		
G6	VI01	I/O	GPIO[22]	GPIO		
K6	VI01	I/O	GPIO[23]	GPIO		
H8	VI01	I/O	GPIO[24]	GPIO		
G5	VI01	I/O	GPIO[25]	GPIO		
H6	VI01	I/O	GPIO[26]	GPIO		
K5	VI01	I/O	GPIO[27]	GPIO		
J5	VI01	I/O	GPIO[28]	GPIO		
H5	VI01	I/O	GPIO[29]	GPIO		
G4	VI01	I/O	GPIO[30]	PMODE[0]		
H4	VI01	I/O	GPIO[31]	PMODE[1]		
L4	VI01	I/O	GPIO[32]	PMODE[2]		
L8			NC	No Connect		
C5	CVDDQ	I	RESET#	Active Low. Hardware Reset.		
				8b MMC Configuration	SD+GPIO Configuration	GPIO Configuration
K2	VI02	I/O	GPIO[33]	S0_SD0	S0_SD0	GPIO
J4	VI02	I/O	GPIO[34]	S0_SD1	S0_SD1	GPIO
K1	VI02	I/O	GPIO[35]	S0_SD2	S0_SD2	GPIO

Table 7. Pin List (continued)

Pin No.	Power Domain	I/O	Name	Description								
J2	VI02	I/O	GPIO[36]	S0_SD3	S0_SD3				GPIO			
J3	VI02	I/O	GPIO[37]	S0_SD4	GPIO				GPIO			
J1	VI02	I/O	GPIO[38]	S0_SD5	GPIO				GPIO			
H2	VI02	I/O	GPIO[39]	S0_SD6	GPIO				GPIO			
H3	VI02	I/O	GPIO[40]	S0_SD7	GPIO				GPIO			
F4	VI02	I/O	GPIO[41]	S0_CMD	S0_CMD				GPIO			
G2	VI02	I/O	GPIO[42]	S0_CLK	S0_CLK				GPIO			
G3	VI02	I/O	GPIO[43]	S0_WP	S0_WP				GPIO			
F3	VI02	I/O	GPIO[44]	S0S1_INS	S0S1_INS				GPIO			
F2	VI02	I/O	GPIO[45]	MMC0_RST_OUT	GPIO				GPIO			
				8b MMC	SD+UART	SD+SPI	SD+GPIO	GPIO	GPIO+UART+I2S	SD+I2S	UART+SPI+I2S	
F5	VI03	I/O	GPIO[46]	S1_SD0	S1_SD0	S1_SD0	S1_SD0	GPIO	GPIO	S1_SD0	UART_RTS	
E1	VI03	I/O	GPIO[47]	S1_SD1	S1_SD1	S1_SD1	S1_SD1	GPIO	GPIO	S1_SD1	UART_CTS	
E5	VI03	I/O	GPIO[48]	S1_SD2	S1_SD2	S1_SD2	S1_SD2	GPIO	GPIO	S1_SD2	UART_TX	
E4	VI03	I/O	GPIO[49]	S1_SD3	S1_SD3	S1_SD3	S1_SD3	GPIO	GPIO	S1_SD3	UART_RX	
D1	VI03	I/O	GPIO[50]	S1_CMD	S1_CMD	S1_CMD	S1_CMD	GPIO	I2S_CLK	S1_CMD	I2S_CLK	
D2	VI03	I/O	GPIO[51]	S1_CLK	S1_CLK	S1_CLK	S1_CLK	GPIO	I2S_SD	S1_CLK	I2S_SD	
D3	VI03	I/O	GPIO[52]	S1_WP	S1_WP	S1_WP	S1_WP	GPIO	I2S_WS	S1_WP	I2S_WS	
D4	VIO4	I/O	GPIO[53]	S1_SD4	UART_RTS	SPI_SCK	GPIO	GPIO	UART_RTS	GPIO	SPI_SCK	
C1	VIO4	I/O	GPIO[54]	S1_SD5	UART_CTS	SPI_SSN	GPIO	GPIO	UART_CTS	I2S_CLK	SPI_SSN	
C2	VIO4	I/O	GPIO[55]	S1_SD6	UART_TX	SPI_MISO	GPIO	GPIO	UART_TX	I2S_SD	SPI_MISO	
D5	VIO4	I/O	GPIO[56]	S1_SD7	UART_RX	SPI_MOSI	GPIO	GPIO	UART_RX	I2S_WS	SPI_MOSI	
C4	VIO4	I/O	GPIO[57]	MMC1_RST_OUT	GPIO	GPIO	GPIO	GPIO	I2S_MCLK	I2S_MCLK	I2S_MCLK	
C9			NC	No Connect								
A3			NC	No Connect								
A4			NC	No Connect								
A6			NC	No Connect								
A5			NC	No Connect								
A9	VBATT/ VBUS	I/O	D+	USB (HS/FS) Data Plus								
A10	VBATT/ VBUS	I/O	D-	USB (HS/FS) Data Minus								
A11			NC	No Connect								
B2	CVDDQ	I	FSLC[0]	FSLC[0]								
C6	AVDD	I/O	XTALIN	XTALIN								

Table 7. Pin List (continued)

Pin No.	Power Domain	I/O	Name	Description
C7	AVDD	I/O	XTALOUT	XTALOUT
B4	CVDDQ	I	FSLC[1]	FSLC[1]
E6	CVDDQ	I	FSLC[2]	FSLC[2]
D7	CVDDQ	I	CLKIN	CLKIN
D6	CVDDQ	I	CLKIN_32	CLKIN_32
D9	VIO5	I/O	I ² C_GPIO[58]	SCL (Serial Clock) for I ² C Bus Interface
D10	VIO5	I/O	I ² C_GPIO[59]	SDA (Serial Data) for I ² C Bus Interface
E7	VIO5	I	TDI	TDI
C10	VIO5	O	TDO	TDO
B11	VIO5	I	TRST#	TRST#
E8	VIO5	I	TMS	TMS
F6	VIO5	I	TCK	TCK
D11			NC	No Connect
E10		PWR	VBATT	
B10		PWR	VDD	
A1		PWR	VSS	
E11		PWR	VBUS	
D8		PWR	VSS	
H11		PWR	VIO1	
E2		PWR	VSS	
L9		PWR	VIO1	
G1		PWR	VSS	
F1		PWR	VIO2	
G11		PWR	VSS	
E3		PWR	VIO3	
L1		PWR	VSS	
B1		PWR	VIO4	
L6		PWR	VSS	
B6		PWR	CVDDQ	
B5			NC	
A2			NC	
C11		PWR	VIO5	
L11		PWR	VSS	
A7		PWR	AVDD	
B7		PWR	AVSS	
C3		PWR	VDD	
B8		PWR	VSS	
E9		PWR	VDD	
B9		PWR	VSS	
F11		PWR	VDD	
H1		PWR	VDD	
L7		PWR	VDD	

Table 7. Pin List (continued)

Pin No.	Power Domain	I/O	Name	Description
J11		PWR	VDD	
L5		PWR	VDD	
K4		PWR	VSS	
L3		PWR	VSS	
K3		PWR	VSS	
L2		PWR	VSS	
A8		PWR	VSS	
				Precision Resistors
C8	VBUS/ VBATT	I/O	R_usb2	Precision resistor for USB 2.0 (Connect a 6.04 kΩ+/-1% resistor between this pin and GND)
B3			NC	No Connect

AC Timing Parameters

Storage Port Timing

The S0-Port and S1-Port support the MMC Specification Version 4.4 and SD Specification Version 2.0. [Table 8](#) lists the timing parameters for S0-Port and S1-Port of SD2.

Table 8. S-Port Timing Parameters^[2]

Parameter	Description	Min	Max	Units
MMC-20				
tSDIS CMD	Host input setup time for CMD	4.8	–	ns
tSDIS DAT	Host input setup time for DAT	4.8	–	ns
tSDIH CMD	Host input hold time for CMD	4.4	–	ns
tSDIH DAT	Host input hold time for DAT	4.4	–	ns
tSDOS CMD	Host output setup time for CMD	5	–	ns
tSDOS DAT	Host output setup time for DAT	5	–	ns
tSDOH CMD	Host output hold time for CMD	5	–	ns
tSDOH DAT	Host output hold time for DAT	5	–	ns
tSCLKR	Clock rise time	–	2	ns
tSCLKF	Clock fall time	–	2	ns
tSDCK	Clock cycle time	50	–	ns
SDFREQ	Clock frequency		20	MHz
tSDCLKOD	Clock duty cycle	40	60	%
MMC-26				
tSDIS CMD	Host input setup time for CMD	10	–	ns
tSDIS DAT	Host input setup time for DAT	10	–	ns
tSDIH CMD	Host input hold time for CMD	9	–	ns
tSDIH DAT	Host input hold time for DAT	9	–	ns
tSDOS CMD	Host output setup time for CMD	3	–	ns
tSDOS DAT	Host output setup time for DAT	3	–	ns
tSDOH CMD	Host output hold time for CMD	3	–	ns
tSDOH DAT	Host output hold time for DAT	3	–	ns
tSCLKR	Clock rise time	–	2	ns
tSCLKF	Clock fall time	–	2	ns
tSDCK	Clock cycle time	38.5	–	ns
SDFREQ	Clock frequency		26	MHz
tSDCLKOD	Clock duty cycle	40	60	%

Note

2. All parameters guaranteed by design and validated through characterization.

Table 8. S-Port Timing Parameters^[2] (continued)

Parameter	Description	Min	Max	Units
MC-HS				
tSDIS CMD	Host input setup time for CMD	4	–	ns
tSDIS DAT	Host input setup time for DAT	4	–	ns
tSDIH CMD	Host input hold time for CMD	3	–	ns
tSDIH DAT	Host input hold time for DAT	3	–	ns
tSDOS CMD	Host output setup time for CMD	3	–	ns
tSDOS DAT	Host output setup time for DAT	3	–	ns
tSDOH CMD	Host output hold time for CMD	3	–	ns
tSDOH DAT	Host output hold time for DAT	3	–	ns
tSCLKR	Clock rise time	–	2	ns
tSCLKF	Clock fall time	–	2	ns
tSDCK	Clock cycle time	19.2	–	ns
SDFREQ	Clock frequency	–	52	MHz
tSDCLKOD	Clock duty cycle	40	60	%
MMC-DDR52				
tSDIS CMD	Host input setup time for CMD	4	–	ns
tSDIS DAT	Host input setup time for DAT	0.56	–	ns
tSDIH CMD	Host input hold time for CMD	3	–	ns
tSDIH DAT	Host input hold time for DAT	2.58	–	ns
tSDOS CMD	Host output setup time for CMD	3	–	ns
tSDOS DAT	Host output setup time for DAT	2.5	–	ns
tSDOH CMD	Host output hold time for CMD	3	–	ns
tSDOH DAT	Host output hold time for DAT	2.5	–	ns
tSCLKR	Clock rise time	–	2	ns
tSCLKF	Clock fall time	–	2	ns
tSDCK	Clock cycle time	19.2	–	ns
SDFREQ	Clock frequency	–	52	MHz
tSDCLKOD	Clock duty cycle	45	55	%
SD-Default Speed (SDR12)				
tSDIS CMD	Host input setup time for CMD	24	–	ns
tSDIS DAT	Host input setup time for DAT	24	–	ns
tSDIH CMD	Host input hold time for CMD	2.5	–	ns
tSDIH DAT	Host input hold time for DAT	2.5	–	ns
tSDOS CMD	Host output setup time for CMD	5	–	ns
tSDOS DAT	Host output setup time for DAT	5	–	ns
tSDOH CMD	Host output hold time for CMD	5	–	ns
tSDOH DAT	Host output hold time for DAT	5	–	ns
tSCLKR	Clock rise time	–	2	ns
tSCLKF	Clock fall time	–	2	ns
tSDCK	Clock cycle time	40	–	ns
SDFREQ	Clock frequency	–	25	MHz
tSDCLKOD	Clock duty cycle	40	60	%

Table 8. S-Port Timing Parameters^[2] (continued)

Parameter	Description	Min	Max	Units
SD-High-Speed(SDR25)				
tSDIS CMD	Host input setup time for CMD	4	–	ns
tSDIS DAT	Host input setup time for DAT	4	–	ns
tSDIH CMD	Host input hold time for CMD	2.5	–	ns
tSDIH DAT	Host input hold time for DAT	2.5	–	ns
tSDOS CMD	Host output setup time for CMD	6	–	ns
tSDOS DAT	Host output setup time for DAT	6	–	ns
tSDOH CMD	Host output hold time for CMD	2	–	ns
tSDOH DAT	Host output hold time for DAT	2	–	ns
tSCLKR	Clock rise time	–	2	ns
tSCLKF	Clock fall time	–	2	ns
tSDCK	Clock cycle time	20	–	ns
SDFREQ	Clock frequency	–	50	MHz
tSDCLKOD	Clock duty cycle	40	60	%
SD-SDR50				
tSDIS CMD	Host input setup time for CMD	1.5	–	ns
tSDIS DAT	Host input setup time for DAT	1.5	–	ns
tSDIH CMD	Host input hold time for CMD	2.5	–	ns
tSDIH DAT	Host input hold time for DAT	2.5	–	ns
tSDOS CMD	Host output setup time for CMD	3	–	ns
tSDOS DAT	Host output setup time for DAT	3	–	ns
tSDOH CMD	Host output hold time for CMD	0.8	–	ns
tSDOH DAT	Host output hold time for DAT	0.8	–	ns
tSCLKR	Clock rise time	–	2	ns
tSCLKF	Clock fall time	–	2	ns
tSDCK	Clock cycle time	10	–	ns
SDFREQ	Clock frequency	–	100	MHz
tSDCLKOD	Clock duty cycle	40	60	%
SD-DDR50				
tSDIS CMD	Host input setup time for CMD	4	–	ns
tSDIS DAT	Host input setup time for DAT	0.92	–	ns
tSDIH CMD	Host input hold time for CMD	2.5	–	ns
tSDIH DAT	Host input hold time for DAT	2.5	–	ns
tSDOS CMD	Host output setup time for CMD	6	–	ns
tSDOS DAT	Host output setup time for DAT	3	–	ns
tSDOH CMD	Host output hold time for CMD	0.8	–	ns
tSDOH DAT	Host output hold time for DAT	0.8	–	ns
tSCLKR	Clock rise time	–	2	ns
tSCLKF	Clock fall time	–	2	ns
tSDCK	Clock cycle time	20	–	ns
SDFREQ	Clock frequency	–	50	MHz
tSDCLKOD	Clock duty cycle	45	55	%

I²C Interface Timing

I²C Timing

Figure 3. I²C Timing Definition

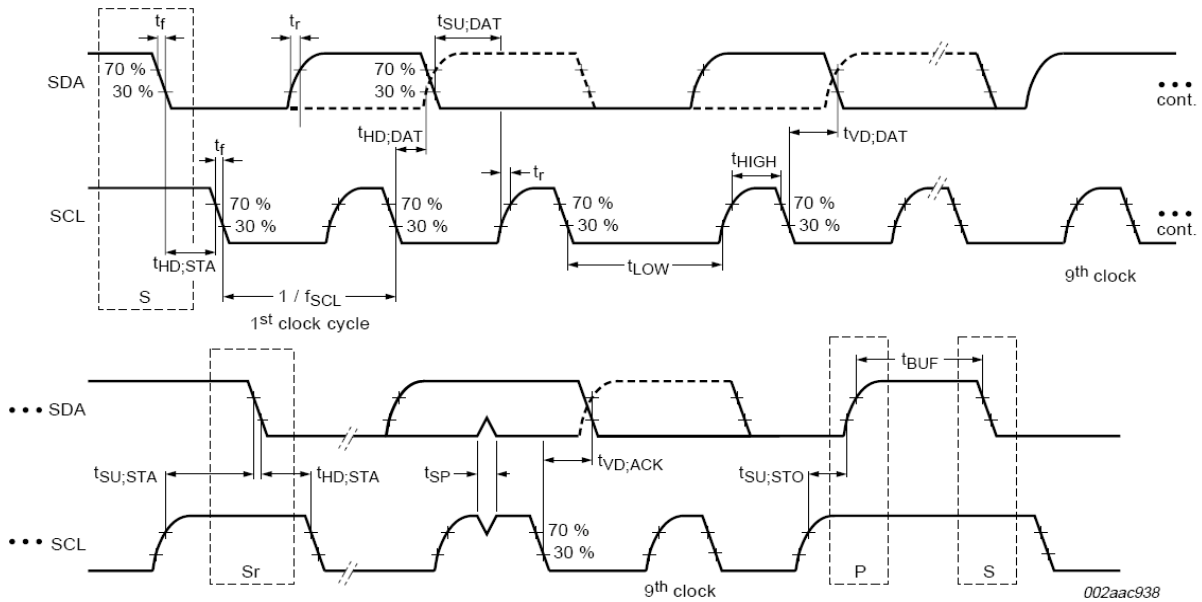

Table 9. I²C Timing Parameters^[3]

Parameter	Description	Min	Max	Units
I²C Standard Mode Parameters				
fSCL	SCL clock frequency	0	100	kHz
tHD:STA	Hold time START condition	4	–	μs
tLOW	LOW period of the SCL	4.7	–	μs
tHIGH	HIGH period of the SCL	4	–	μs
tSU:STA	Setup time for a repeated START condition	4.7	–	μs
tHD:DAT	Data hold time	0	–	μs
tSU:DAT	Data setup time	250	–	ns
t _r	Rise time of both SDA and SCL signals	–	1000	ns
t _f	Fall time of both SDA and SCL signals	–	300	ns
tSU:STO	Setup time for STOP condition	4	–	μs
tBUF	Bus free time between a STOP and START condition	4.7	–	μs
tVD:DAT	Data valid time	–	3.45	μs
tVD:ACK	Data valid ACK	–	3.45	μs
tSP	Pulse width of spikes that must be suppressed by input filter	n/a	n/a	

Note

3. All parameters guaranteed by design and validated through characterization.

Table 9. I²C Timing Parameters^[3] (continued)

Parameter	Description	Min	Max	Units
I²C Fast Mode Parameters				
fSCL	SCL clock frequency	0	400	kHz
tHD:STA	Hold time START condition	0.6	–	μs
tLOW	LOW period of the SCL	1.3	–	μs
tHIGH	HIGH period of the SCL	0.6	–	μs
tSU:STA	Setup time for a repeated START condition	0.6	–	μs
tHD:DAT	Data hold time	0	–	μs
tSU:DAT	Data setup time	100	–	ns
tr	Rise time of both SDA and SCL signals	–	300	ns
tf	Fall time of both SDA and SCL signals	–	300	ns
tSU:STO	Setup time for STOP condition	0.6	–	μs
tBUF	Bus-free time between a STOP and START condition	1.3	–	μs
tVD:DAT	Data valid time	–	0.9	μs
tVD:ACK	Data valid ACK	–	0.9	μs
tSP	Pulse width of spikes that must be suppressed by input filter	0	50	ns
I²C Fast Mode Plus Parameters (Not supported at I2C_VDDQ=1.2V)				
fSCL	SCL clock frequency	0	1000	kHz
tHD:STA	Hold time START condition	0.26	–	μs
tLOW	LOW period of the SCL	0.5	–	μs
tHIGH	HIGH period of the SCL	0.26	–	μs
tSU:STA	Setup time for a repeated START condition	0.26	–	μs
tHD:DAT	Data hold time	0	–	μs
tSU:DAT	Data setup time	50	–	μs
tr	Rise time of both SDA and SCL signals	–	120	ns
tf	Fall time of both SDA and SCL signals	–	120	ns
tSU:STO	Setup time for STOP condition	0.26	–	μs
tBUF	Bus free time between a STOP and START condition	0.5	–	μs
tVD:DAT	Data valid time	–	0.45	μs
tVD:ACK	Data valid ACK	–	0.55	μs
tSP	Pulse width of spikes that must be suppressed by input filter	0	50	ns

I²S Timing Diagram

Figure 4. I²S Transmit Cycle

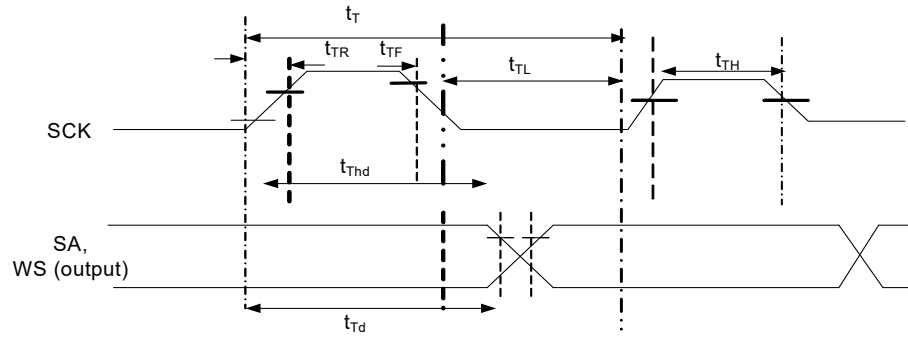

Table 10. I²S Timing Parameters^[4]

Parameter	Description	Min	Max	Units
t_T	I ² S transmitter clock cycle	T_{tr}	–	ns
t_{TL}	I ² S transmitter cycle LOW period	$0.35 T_{tr}$	–	ns
t_{TH}	I ² S transmitter cycle HIGH period	$0.35 T_{tr}$	–	ns
t_{TR}	I ² S transmitter rise time	–	$0.15 T_{tr}$	ns
t_{TF}	I ² S transmitter fall time	–	$0.15 T_{tr}$	ns
t_{Thd}	I ² S transmitter data hold time	0	–	ns
t_{Td}	I ² S transmitter delay time	–	$0.8t_T$	ns

Note t_T is selectable through clock gears. Max T_{tr} is designed for 96-kHz codec at 32 bits to be 326 ns (3.072 MHz).

Note

4. All parameters guaranteed by design and validated through characterization.

SPI Timing Specification

Figure 5. SPI Timing

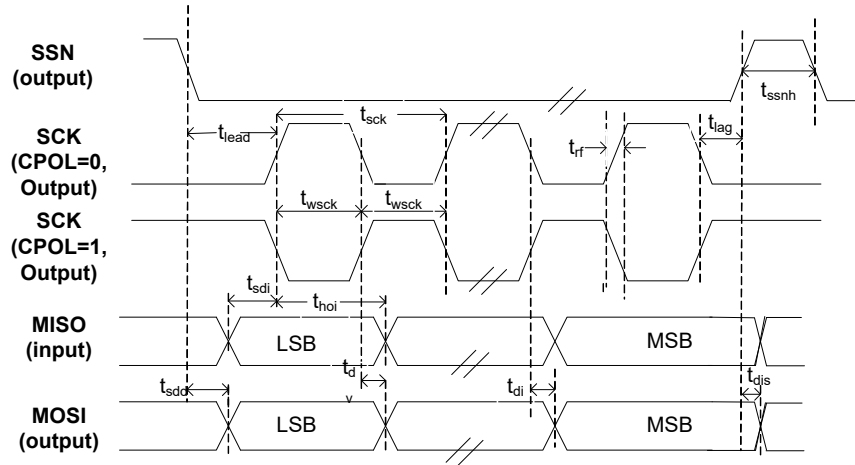

SPI Master Timing for CPHA = 0

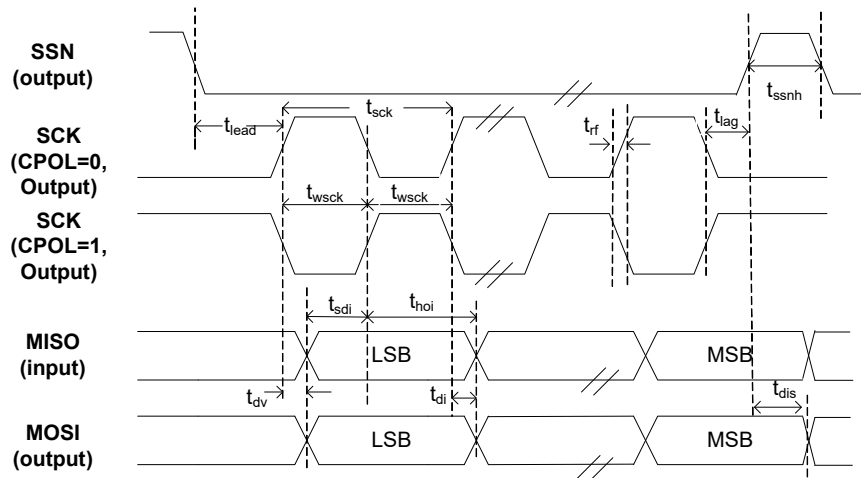

SPI Master Timing for CPHA = 1

Table 11. SPI Timing Parameters^[5]

Parameter	Description	Min	Max	Units
fop	Operating frequency	0	33	MHz
tsck	Cycle time	30	–	ns
twsck	Clock high/low time	13.5	–	ns
tlead	SSN-SCK lead time	$1/2 \text{ tsck}^{[6]} - 5$	$1.5 \text{ tsck}^{[6]} + 5$	ns
tlag	Enable lag time	0.5	$1.5 \text{ tsck}^{[6]} + 5$	ns
trf	Rise/fall time	–	8	ns
tsdd	Output SSN to valid data delay time	–	5	ns
tdv	Output data valid time	–	5	ns
tdi	Output data invalid	0	–	ns
tssnh	Minimum SSN high time	10	–	ns
tsdi	Data setup time input	8	–	ns
thoi	Data hold time input	0	–	ns
tdis	Disable data output on SSN high	0	–	ns

Notes

5. All parameters guaranteed by design and validated through characterization.
6. Depends on LAG and LEAD setting in the SPI_CONFIG register.

Absolute Maximum Ratings

Exceeding maximum ratings may shorten the useful life of the device.

Storage temperature	-65 °C to +150 °C
Ambient temperature with power supplied (Industrial)	-40 °C to +85 °C
Supply voltage to ground potential V_{DD} , A_{VDDQ}	1.25 V
$S2_{VDDQ}$, $S1_{VDDQ}$, $S0_{VDDQ}$, V_{IO4} , V_{IO5}	3.6 V
$U3TX_{VDDQ}$, $U3RX_{VDDQ}$	1.25 V
DC input voltage to any input pin	$VCC + 0.3$
DC voltage applied to outputs in High Z State	$VCC + 0.3$ (VCC is the corresponding I/O voltage)
Static discharge voltage ESD protection levels:	
■ ±2.2-KV human body model (HBM) based on JESD22-A114	

- Additional ESD Protection levels on D+, D-, VBUS, GND pins U-port and GPIO pins LPP-Port
 - ±6-KV contact discharge, ±8-KV air gap discharge based on IEC61000-4-2 level 3A, ±8-KV contact discharge, and ±15-KV air gap discharge based on IEC61000-4-2 level 4C
- Latch-up current
- Maximum output short circuit current for all I/O configurations. ($V_{out} = 0$ V)

Operating Conditions

TA (ambient temperature under bias)	
Commercial	0 °C to +70 °C
Industrial	-40 °C to +85 °C
V_{DD} , A_{VDDQ} , $U3TX_{VDDQ}$, $U3RX_{VDDQ}$ supply voltage	1.15 V to 1.25 V
V_{BATT} supply voltage	3.2 V to 6 V
$S2_{VDDQ}$, $S1_{VDDQ}$, $S0_{VDDQ}$, V_{IO4} , C_{VDDQ} supply voltage	1.7 V to 3.6 V
V_{IO5} supply voltage	1.15 V to 3.6 V

DC Specifications

Table 12. DC Specifications

Parameter	Description	Min	Max	Units	Notes
V_{DD}	Core voltage supply	1.15	1.25	V	1.2-V typical
A_{VDD}	Analog voltage supply	1.15	1.25	V	1.2-V typical
V_{IO2}	SD/ MMC/ CF I/O power supply domain	1.7	3.6	V	1.8-, 2.5-, and 3.3-V typical
V_{IO3}	SD/MMC I/O power supply domain	1.7	3.6	V	1.8-, 2.5-, and 3.3-V typical
V_{IO1}	GPIO/ CF I/O power supply domain	1.7	3.6	V	1.8-, 2.5-, and 3.3-V typical
V_{IO4}	GPIO/ I/O power supply domain	1.7	3.6	V	1.8-, 2.5-, and 3.3-V typical
V_{BATT}	USB voltage supply	3.2	6	V	3.7-V typical
V_{BUS}	USB voltage supply	4.0	6	V	5-V typical
C_{VDDQ}	Clock voltage supply	1.7	3.6	V	1.8-, 3.3-V typical
V_{IO5}	I ² C voltage supply	1.2	3.3	V	1.2-, 1.8-, 2.5-, and 3.3-V typical
V_{IH1}	Input HIGH voltage 1	$0.625 \times VCC$	$VCC + 0.3$	V	For $2.0\text{ V} \leq V_{CC} \leq 3.6\text{ V}$ (except USB port). VCC is the corresponding I/O voltage supply.
V_{IH2}	Input HIGH voltage 2	$VCC - 0.4$	$VCC + 0.3$	V	For $1.7\text{ V} \leq V_{CC} \leq 2.0\text{ V}$ (except USB port). VCC is the corresponding I/O voltage supply.
V_{IL}	Input LOW voltage	-0.3	$0.25 \times VCC$	V	VCC is the corresponding I/O voltage supply.
V_{OH}	Output HIGH voltage	$0.9 \times VCC$	-	V	$I_{OH}(\text{max}) = -100\ \mu\text{A}$ tested at quarter drive strength. VCC is the corresponding I/O voltage supply.
V_{OL}	Output LOW voltage	-	$0.1 \times VCC$	V	$I_{OL}(\text{min}) = +100\ \mu\text{A}$ tested at quarter drive strength. VCC is the corresponding I/O voltage supply.

Table 12. DC Specifications (continued)

Parameter	Description	Min	Max	Units	Notes
I _{IX}	Input leakage current for all pins	-1	1	μA	All I/O signals held at V _{DDQ} (For I/Os that have a pull-up/down resistor connected, the leakage current increases by V _{DDQ} /R _{pu} or V _{DDQ} /R _{pd})
I _{OZ}	Output High-Z leakage current for all pins	-1	1	μA	All I/O signals held at VDDQ
I _{CC} Core	Core and Analog Voltage Operating Current	-	150	mA	Total current through AVDD, VDD
I _{CC} USB	USB voltage supply operating current	-	20	mA	
I _{SB1}	Total suspend current during Suspend Mode with USB 3.0 PHY enabled (L1 mode)	-	-	mA	Core current: 1.5 mA I/O current: 20 uA USB current: 2 mA For typical PVT (Typical silicon, all power supplies at their respective nominal levels at 25 °C.)
I _{SB2}	Total suspend current during Suspend Mode with USB 3.0 PHY disabled (L2 mode)	-	-	mA	Core current: 250 uA I/O current: 20 uA USB current: 1.2 mA For typical PVT (Typical silicon, all power supplies at their respective nominal levels at 25 °C.)
I _{SB3}	Total Standby Current during Standby Mode (L3 mode)	-	-	μA	Core current: 60 uA I/O current: 20 uA USB current: 40 uA For typical PVT (Typical silicon, all power supplies at their respective nominal levels at 25 °C.)
I _{SB4}	Total Standby Current during Core Power Down Mode (L4 mode)	-	-	μA	Core current: 0 uA I/O current: 20 uA USB current: 40 uA For typical PVT (Typical silicon, all power supplies at their respective nominal levels at 25 °C.)
V _{RAMP}	Voltage Ramp Rate on Core and I/O Supplies	0.2	50	V/ms	Voltage ramp must be monotonic
V _N	Noise Level Permitted on VDD and I/O Supplies	-	100	mV	Max p-p noise level permitted on all supplies except A _{VDD}
V _{N_AVDD}	Noise Level Permitted on AVDD Supply	-	20	mV	Max p-p noise level permitted on A _{VDD}

Thermal Characteristics

Table 13. Thermal Characteristics

Parameter	Description	Value	Unit
T _J MAX	Maximum Junction Temperature	125	°C
Θ _{JA}	Thermal resistance (junction to ambient)	34.66	°C/W
Θ _{JB}	Thermal resistance (junction to board)	27.03	°C/W
Θ _{JC}	Thermal resistance (junction to case)	13.57	°C/W

Reset Sequence

The hard reset sequence requirements for SD2 are specified in the following table.

Table 14. Reset and Standby Timing Parameters

Parameter	Definition	Conditions	Min (ms)	Max (ms)
tRPW	Minimum RESET# pulse width	Clock Input	1	–
		Crystal Input	1	–
tRH	Minimum high on RESET#		5	–
tRR	Reset Recovery Time (after which Boot loader begins firmware download)	Clock Input	1	–
		Crystal Input	5	–
tSBY	Time to enter Standby/Suspend (from the time MAIN_CLOCK_EN/ MAIN_POWER_EN bit is set)		–	1
tWU	Time to wakeup from standby	Clock Input	1	–
		Crystal Input	5	–
tWH	Minimum time before Standby/Suspend source may be reasserted		5	–

Figure 6. Reset Sequence

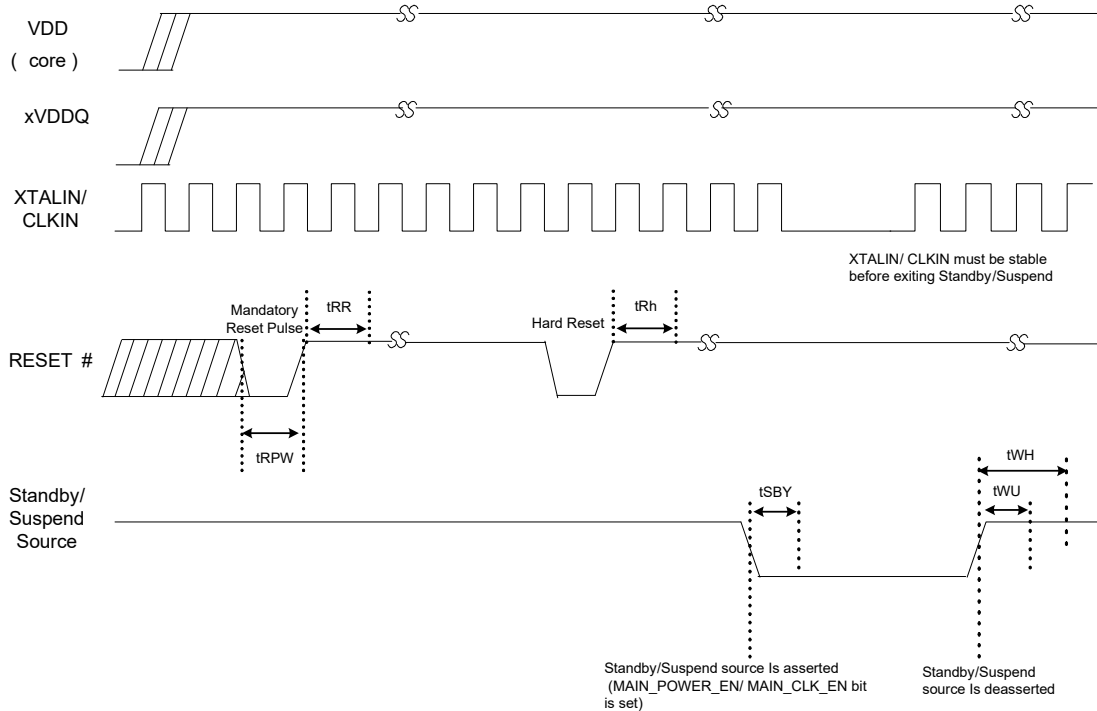

Package Diagram

Figure 7. 121-ball FBGA (10 × 10 × 1.20 mm) Package Outline, 001-54471

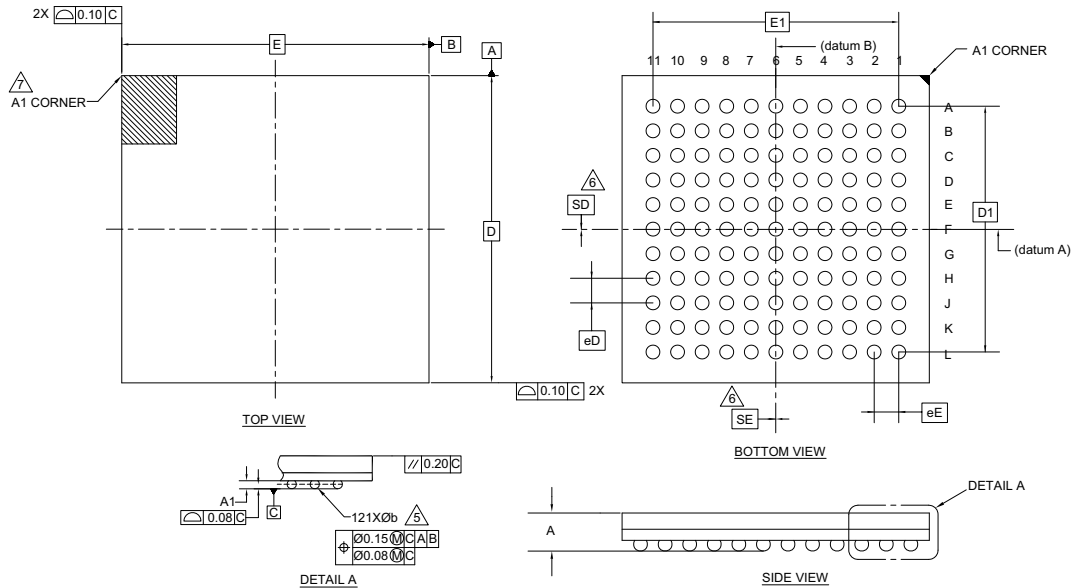

SYMBOL	DIMENSIONS		
	MIN.	NOM.	MAX.
A	-	-	1.20
A1	0.15	-	-
D	10.00 BSC		
E	10.00 BSC		
D1	8.00 BSC		
E1	8.00 BSC		
MD	11		
ME	11		
N	121		
∅ b	0.25	0.30	0.35
eD	0.80 BSC		
eE	0.80 BSC		
SD	0.00		
SE	0.00		

NOTES:

- ALL DIMENSIONS ARE IN MILLIMETERS.
- SOLDER BALL POSITION DESIGNATION PER JEP95, SECTION 3, SPP-020.
- "e" REPRESENTS THE SOLDER BALL GRID PITCH.
- SYMBOL "MD" IS THE BALL MATRIX SIZE IN THE "D" DIRECTION. SYMBOL "ME" IS THE BALL MATRIX SIZE IN THE "E" DIRECTION. N IS THE NUMBER OF POPULATED SOLDER BALL POSITIONS FOR MATRIX SIZE MD X ME.
- DIMENSION "b" IS MEASURED AT THE MAXIMUM BALL DIAMETER IN A PLANE PARALLEL TO DATUM C.
- "SD" AND "SE" ARE MEASURED WITH RESPECT TO DATUMS A AND B AND DEFINE THE POSITION OF THE CENTER SOLDER BALL IN THE OUTER ROW. WHEN THERE IS AN ODD NUMBER OF SOLDER BALLS IN THE OUTER ROW, "SD" OR "SE" = 0. WHEN THERE IS AN EVEN NUMBER OF SOLDER BALLS IN THE OUTER ROW, "SD" = eD/2 AND "SE" = eE/2.
- A1 CORNER TO BE IDENTIFIED BY CHAMFER, LASER OR INK MARK METALIZED MARK, INDENTATION OR OTHER MEANS.
- "+" INDICATES THE THEORETICAL CENTER OF DEPOPULATED SOLDER BALLS.

001-54471 *F

Ordering Information

Table 15. Ordering Information

Ordering Code	SD/eMMC SDIO Ports	RAID Support	SRAM (KB)	Package Type
CYUSB2024-BZXI	2	No	512	121-ball BGA
CYUSB2025-BZXI	2	Yes	512	121-ball BGA

Ordering Code Definitions

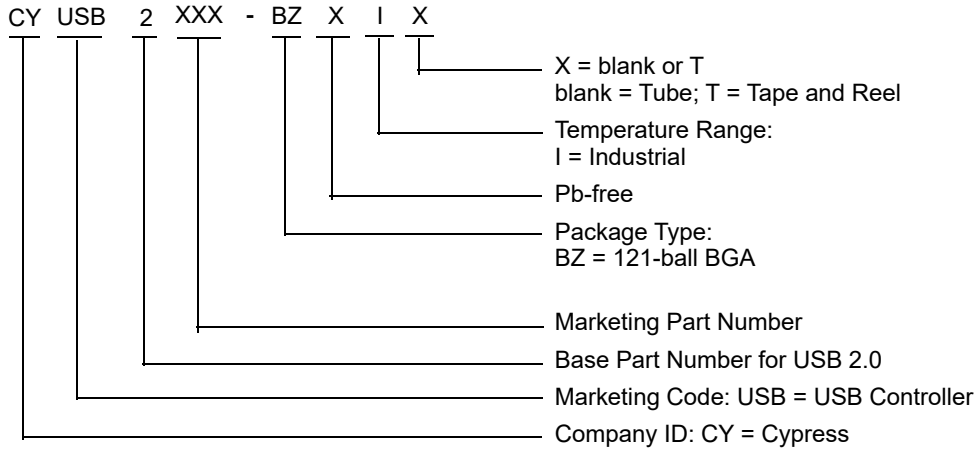

Acronyms

Acronym	Description
BGA	ball grid array
MMC	multimedia card
PLL	phase locked loop
RAID	Redundant Array of Independent Disks
SD	secure digital
SDIO	secure digital input / output
SLC	single-level cell
USB	universal serial bus

Document Conventions

Units of Measure

Symbol	Unit of Measure
°C	degree Celsius
μA	microamperes
μs	microseconds
mA	milliamperes
MBps	Megabytes per second
MHz	mega hertz
ms	milliseconds
ns	nanoseconds
Ω	ohms
pF	pico Farad
V	volts

Errata

This section describes the errata for SD2 USB and Mass Storage Peripheral Controller. Details include errata trigger conditions, scope of impact, available workaround, and silicon revision applicability. Contact your local Cypress Sales Representative if you have questions.

Part Numbers Affected

Part Number	Device Characteristics
CYUSB2024-BZXI	All Variants
CYUSB2025-BZXI	All Variants

Qualification Status

Product Status: Production

Errata Summary

The following table defines the errata applicability to available SD2 USB and Mass Storage Peripheral Controller family devices.

Items	[Part Number]	Silicon Revision	Fix Status
1. Turning off VIO1 during Normal, Suspend and Standby modes causes the SD2 to stop working.	CYUSB2024-BZXI CYUSB2025-BZXI	Rev. D	Workaround provided
2. USB enumeration failure in USB boot mode when SD2 is self-powered.	CYUSB2024-BZXI CYUSB2025-BZXI	Rev. D	Workaround provided
3. Bus collision is seen when the I2C block is used as a master in the I2C Multi-master configuration.	CYUSB2024-BZXI CYUSB2025-BZXI	Rev. D	Use SD2 in single I2C master environment only

1. Turning off VIO1 during Normal, Suspend and Standby modes causes the SD2 to stop working.

■Problem Definition

Turning off the VIO1 during Normal, Suspend and Standby modes will cause the SD2 to stop working.

■Parameters Affected

N/A

■Trigger Conditions

This condition is triggered when the VIO1 is turned off during Normal, Suspend, and Standby modes.

■Scope Of Impact

SD2 stops working.

■Workaround

VIO1 must stay on during Normal, Suspend, and Standby modes.

■Fix Status

No fix. Workaround is required.

2. USB enumeration failure in USB boot mode when SD2 is self-powered.

■Problem Definition

When SD2 is self-powered and not connected to the USB host, it enters low-power mode and does not wake up when connected to USB host afterwards. This is because the bootloader does not check the VBUS pin on the connector to detect USB connection. It expects that the USB bus is connected to the host when it is powered on.

■Parameters Affected

N/A

■Trigger Conditions

This condition is triggered when SD2 is self-powered in USB boot mode.

■Scope Of Impact

Device does not enumerate

■Workaround

Reset the SD2 device after connecting to USB host using the RESET pin.

■Fix Status

No fix. Workaround is required.

3. Bus collision is seen when the I²C block is used as a master in the I²C Multi-master configuration.

■Problem Definition

When SD2 is used as a master in the I²C multi-master configuration, there can be occasional bus collisions.

■Parameters Affected

NA

■Trigger Conditions

This condition is triggered only when the SD2 I²C block operates in Multi-master configuration.

■Scope Of Impact

The SD2 I²C block can transmit data when the I²C bus is not idle leading to bus collisions.

■Workaround

Use SD2 in a single I2C master environment only.

■Fix Status

No fix. Workaround is required.

Document History Page

Document Title: CYUSB202X, SD2™ USB and Mass Storage Peripheral Controller Document Number: 001-87710				
Revision	ECN	Orig. of Change	Submission Date	Description of Change
**	4016299	GSZ	05/31/2013	New data sheet.
*A	4114923	GSZ	09/05/2013	Changed status from “Company Confidential” to “Final”. Updated to new template.
*B	5329287	RAJV	06/29/2016	Updated Package Diagram : spec 001-54471 – Changed revision from *D to *E. Updated to new template.
*C	5708850	AESATMP7	04/24/2017	Updated Cypress Logo and Copyright.
*D	6274940	ANNR	08/21/2018	Updated Features : Updated description. Updated Functional Overview : Updated USB Interface (U-Port) : Updated Figure 1 . Updated I2S Interface : Updated description. Updated Boot Options : Updated description. Updated Power : Updated description. Updated Power Modes : Updated description. Updated Table 6 . Updated Pinouts : Updated Figure 2 . Updated Pin Descriptions : Updated Table 7 . Updated Operating Conditions : Added Commercial Temperature Range related information. Updated DC Specifications : Updated Table 12 . Added Thermal Characteristics . Updated Package Diagram : spec 001-54471 – Changed revision from *E to *F. Updated Ordering Information : No change in part numbers. Added a column “RAID Support” and added details in that column. Added Errata . Updated to new template.

Sales, Solutions, and Legal Information

Worldwide Sales and Design Support

Cypress maintains a worldwide network of offices, solution centers, manufacturer's representatives, and distributors. To find the office closest to you, visit us at [Cypress Locations](#).

Products

Arm [®] Cortex [®] Microcontrollers	cypress.com/arm
Automotive	cypress.com/automotive
Clocks & Buffers	cypress.com/clocks
Interface	cypress.com/interface
Internet of Things	cypress.com/iot
Memory	cypress.com/memory
Microcontrollers	cypress.com/mcu
PSoC	cypress.com/psoc
Power Management ICs	cypress.com/pmic
Touch Sensing	cypress.com/touch
USB Controllers	cypress.com/usb
Wireless Connectivity	cypress.com/wireless

PSoC[®] Solutions

[PSoC 1](#) | [PSoC 3](#) | [PSoC 4](#) | [PSoC 5LP](#) | [PSoC 6 MCU](#)

Cypress Developer Community

[Community](#) | [Projects](#) | [Video](#) | [Blogs](#) | [Training](#) | [Components](#)

Technical Support

cypress.com/support

© Cypress Semiconductor Corporation, 2013-2018. This document is the property of Cypress Semiconductor Corporation and its subsidiaries, including Spansion LLC ("Cypress"). This document, including any software or firmware included or referenced in this document ("Software"), is owned by Cypress under the intellectual property laws and treaties of the United States and other countries worldwide. Cypress reserves all rights under such laws and treaties and does not, except as specifically stated in this paragraph, grant any license under its patents, copyrights, trademarks, or other intellectual property rights. If the Software is not accompanied by a license agreement and you do not otherwise have a written agreement with Cypress governing the use of the Software, then Cypress hereby grants you a personal, non-exclusive, nontransferable license (without the right to sublicense) (1) under its copyright rights in the Software (a) for Software provided in source code form, to modify and reproduce the Software solely for use with Cypress hardware products, only internally within your organization, and (b) to distribute the Software in binary code form externally to end users (either directly or indirectly through resellers and distributors), solely for use on Cypress hardware product units, and (2) under those claims of Cypress's patents that are infringed by the Software (as provided by Cypress, unmodified) to make, use, distribute, and import the Software solely for use with Cypress hardware products. Any other use, reproduction, modification, translation, or compilation of the Software is prohibited.

TO THE EXTENT PERMITTED BY APPLICABLE LAW, CYPRESS MAKES NO WARRANTY OF ANY KIND, EXPRESS OR IMPLIED, WITH REGARD TO THIS DOCUMENT OR ANY SOFTWARE OR ACCOMPANYING HARDWARE, INCLUDING, BUT NOT LIMITED TO, THE IMPLIED WARRANTIES OF MERCHANTABILITY AND FITNESS FOR A PARTICULAR PURPOSE. No computing device can be absolutely secure. Therefore, despite security measures implemented in Cypress hardware or software products, Cypress does not assume any liability arising out of any security breach, such as unauthorized access to or use of a Cypress product. In addition, the products described in these materials may contain design defects or errors known as errata which may cause the product to deviate from published specifications. To the extent permitted by applicable law, Cypress reserves the right to make changes to this document without further notice. Cypress does not assume any liability arising out of the application or use of any product or circuit described in this document. Any information provided in this document, including any sample design information or programming code, is provided only for reference purposes. It is the responsibility of the user of this document to properly design, program, and test the functionality and safety of any application made of this information and any resulting product. Cypress products are not designed, intended, or authorized for use as critical components in systems designed or intended for the operation of weapons, weapons systems, nuclear installations, life-support devices or systems, other medical devices or systems (including resuscitation equipment and surgical implants), pollution control or hazardous substances management, or other uses where the failure of the device or system could cause personal injury, death, or property damage ("Unintended Uses"). A critical component is any component of a device or system whose failure to perform can be reasonably expected to cause the failure of the device or system, or to affect its safety or effectiveness. Cypress is not liable, in whole or in part, and you shall and hereby do release Cypress from any claim, damage, or other liability arising from or related to all Unintended Uses of Cypress products. You shall indemnify and hold Cypress harmless from and against all claims, costs, damages, and other liabilities, including claims for personal injury or death, arising from or related to any Unintended Uses of Cypress products.

Cypress, the Cypress logo, Spansion, the Spansion logo, and combinations thereof, WICED, PSoC, CapSense, EZ-USB, F-RAM, and Traveo are trademarks or registered trademarks of Cypress in the United States and other countries. For a more complete list of Cypress trademarks, visit cypress.com. Other names and brands may be claimed as property of their respective owners.