



# West Bridge<sup>®</sup> Bay<sup>™</sup> USB and Mass Storage Controller

## Features

- Best-in-class sideload performance (>30 MBps) based on Cypress's proprietary SLIM<sup>®</sup> II technology, enabling direct path from Hi-Speed USB 2.0 to mass storage devices
- USB-IF compliance certified
  - USB 2.0 peripheral
  - High-Speed On-The-Go (HS-OTG) 2.0 host negotiation protocol (HNP) and session request protocol (SRP)
  - Thirty-two endpoints
  - Integrated USB 2.0 transceivers
  - EZ-Dtect<sup>™</sup> – USB charger detection 1.1
  - Accessory charger adaptor (ACA)
  - Integrated Hi-Speed USB 2.0 switch<sup>[1]</sup>
  - CarKit Pass-Through UART functionality on USB
- Mass storage support
  - SD 3.0 (SDXC) UHS-1
  - eMMC 4.4
- System I/O expansion with two secure digital I/O (SDIO) ports
- Native mass storage class (MSC), human interface device (HID), full, and Turbo-MTP<sup>™</sup> support
- Flexible host processor interface
  - Asynchronous non-multiplexed SRAM
  - Synchronous and asynchronous address/data multiplexed SRAM
  - Multimedia card (MMC) slave with eMMC 4.3/4.4 pass-through boot
  - Direct memory access (DMA) slave support over processor interfaces
- Ultra low-power in core power-down mode
  - Less than 60  $\mu$ A with  $V_{BATT}$  on and 20  $\mu$ A with  $V_{BATT}$  off
- Independent and flexible power domains
- Flexible serial peripheral interfaces (SPIs)
  - I<sup>2</sup>C master controller at 1 MHz
  - I<sup>2</sup>S master (transmitter only) with sampling frequencies of 32 kHz, 44.1 kHz, and 48 kHz
  - UART at 4 Mbps
  - SPI master at 33 MHz
- Selectable clocking frequencies
  - 19.2-, 26-, 38.4-, and 52-MHz clock input
  - 19.2-MHz crystal input
  - 32-kHz low-power clock for watchdog timer
- Package options:
  - 5.099 mm  $\times$  4.695 mm  $\times$  0.55 mm, with 0.4 mm pitch small footprint wafer-level chip scale package (WLCSP)
  - 10  $\times$  10 mm, 0.8-mm pitch ball grid array (BGA) package
- Pin compatible with West Bridge<sup>®</sup> Benicia<sup>™</sup> enabling easy migration to USB 3.0

## Applications

- Mobile phones
- Portable media players
- Portable navigation devices
- Personal digital assistant devices
- Digital still/video cameras

### Note

1. Available only with the WLCSP package.

**Logic Block Diagram**

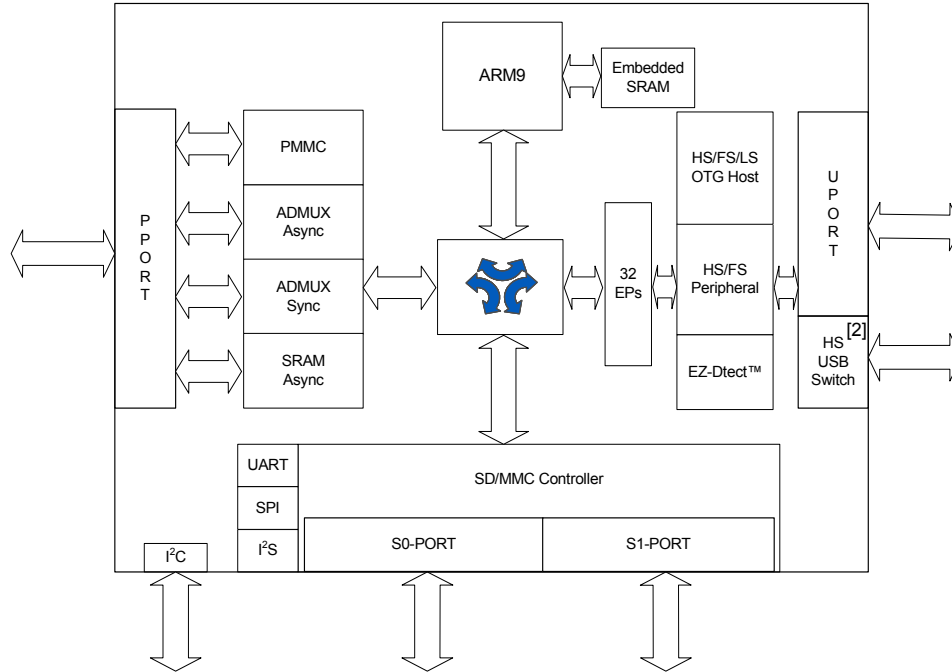

**Note**

2. Available only with the WLCSP package.

**Contents**

<b>Functional Overview</b> .....	<b>4</b>	Low Performance Peripherals Timing .....	38
<b>Interface Description</b> .....	<b>4</b>	SPI Timing Specification .....	41
USB Interface (U-Port) .....	4	<b>Reset Sequence</b> .....	<b>42</b>
Storage Port (S-Port) .....	8	<b>Package Diagram</b> .....	<b>44</b>
Host Processor Interface (P-Port) .....	8	<b>Ordering Information</b> .....	<b>46</b>
Other Interfaces .....	10	Ordering Code Definitions .....	46
<b>Boot Options</b> .....	<b>11</b>	<b>Acronyms</b> .....	<b>47</b>
<b>Reset</b> .....	<b>11</b>	<b>Document Conventions</b> .....	<b>47</b>
Hard Reset .....	11	Units of Measure .....	47
Soft Reset .....	11	<b>Errata</b> .....	<b>48</b>
<b>Clocking</b> .....	<b>11</b>	Part Numbers Affected .....	48
32-kHz Watchdog Timer Clock Input .....	12	Bay and Benicia, USB and	
<b>Power</b> .....	<b>12</b>	Mass Storage Peripheral Controller Qualification Status	48
Power Modes .....	13	Bay and Benicia, USB and	
<b>Configuration Options</b> .....	<b>15</b>	Mass Storage Peripheral Controller Errata Summary .....	48
<b>EMI</b> .....	<b>15</b>	<b>Document History Page</b> .....	<b>50</b>
<b>System-level ESD</b> .....	<b>15</b>	<b>Sales, Solutions, and Legal Information</b> .....	<b>52</b>
<b>Pin Description</b> .....	<b>16</b>	Worldwide Sales and Design Support .....	52
<b>Absolute Maximum Ratings</b> .....	<b>26</b>	Products .....	52
<b>Operating Conditions</b> .....	<b>26</b>	PSoC® Solutions .....	52
<b>DC Specifications</b> .....	<b>26</b>	Cypress Developer Community .....	52
<b>AC Timing Parameters</b> .....	<b>28</b>	Technical Support .....	52
Storage Port Timing .....	28		
Host Processor Interface (P-Port) Timing .....	31		

## Functional Overview

West Bridge Bay™ is a Hi-Speed USB 2.0 West Bridge peripheral controller optimized for all sideloading and streaming applications. It supports the latest removable and embedded mass-storage devices. The SLIM II architecture, supervised by the ARM9 CPU core, enables simultaneous accesses among all the functional Bay ports without affecting the performance of each independent data path. The functional ports are as follows:

- USB port (U-Port) supporting USB 2.0 peripheral and USB 2.0 OTG host
- Mass storage port (S-Port) supporting two independent mass storage devices
- Processor port (P-Port) connecting to a host processor
- Low-performance peripheral port (LPP-Port) providing additional serial interfaces

Bay offers the following advantages:

- USB host (that is, PC) accessing mass storage attached to Bay (U-Port ↔ S-Port access) in a sideloading application. Bay acts as a USB 2.0 peripheral
- USB host exchanging data with the P-Port host processor (P-Port ↔ U-Port access) in a video streaming or tethered modem application. Bay acts as a USB 2.0 peripheral
- P-Port host processor accessing mass storage or I/O devices attached to Bay (P-Port ↔ S-Port access). Bay acts as a mass storage bridge
- P-Port host processor connecting to mass storage or HID attached to Bay's USB port (P-Port ↔ U-Port access). Bay acts as a USB 2.0 OTG host

Each of these access paths can operate independently or simultaneously in an interleaved manner. Bay also supports the USB composite device driver, enabling simultaneous enumeration of multiple independent USB device classes.

## Interface Description

### USB Interface (U-Port)

Bay supports USB peripheral functionality compliant with the USB 2.0 Specification.

- Bay is compliant with the USB OTG supplement revision 2.0. It supports high-speed, full-speed, and low-speed OTG dual-role device capability. As a peripheral, it is capable of high-speed and full-speed. As a host, it is capable of high-speed, full-speed, and low-speed
- Bay supports the Carkit Pass-Through UART functionality on USB D+/D- lines based on the CEA-936A specification

Bay supports up to 32 endpoints with fully configurable buffer sizes.

As a USB peripheral, Bay natively supports MSC and Media Transfer Protocol (MTP) USB peripheral classes. All other device classes are supported in pass-through mode. The external host processor, connected to the P-Port, handles enumeration.

As a USB OTG host, Bay natively supports MSC and HID device classes. All other device classes can be supported with custom firmware. Contact Cypress applications support for details.

When the USB port is not in use, the PHY and transceiver may be disabled for power savings.

The Cypress Vendor ID 0X04B4 is the default VID used for enumeration. This may be changed through firmware.

Figure 1. U-Port Interface Signals

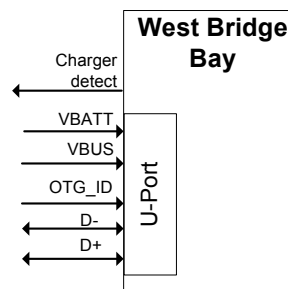

### USB Switch

Bay integrates a high-speed USB 2.0 switch that allows a single USB connector to be shared with another device. The firmware can enable or disable this switch. When the switch is enabled, the USB D+/D- are connected to an external high-speed USB 2.0 PHY. After power-on-reset (POR) in the normal mode of operation, the USB switch is enabled by default. Note that this USB switch is only available with the WLCSP package, not with the BGA package.

### Carkit UART Mode

The U-Port supports the Carkit UART mode (UART over D+/D-) for non-USB serial data transfer. This complies with the CEA-936A specification.

In the Carkit UART mode, the output signaling voltage is 3.3 V. The TXD of UART (output) is mapped to the D- line and the RXD of UART (input) is mapped to the D+ line.

Bay disables the USB transceiver and the D+ and D- pins function as pass-through pins to connect to the host processor UART. When the P-Port is configured to be in the asynchronous ADMux and PMMC modes, the Carkit UART signals are routed to the P-Port. In the asynchronous SRAM and synchronous ADMux modes, the Carkit UART signals are routed to S1-Port GPIOs as shown in Figure 2. Bay supports a baud rate of up to 9600 bps in this mode.

Figure 2. Carokit UART Pass-Through Block Diagram

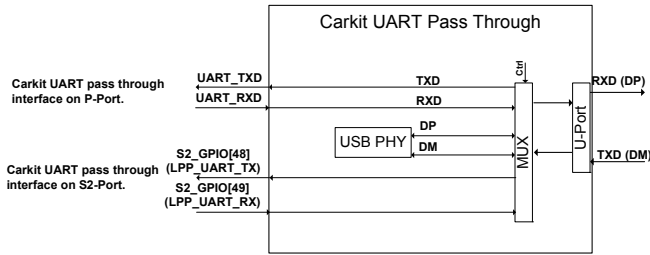

*EZ-Dtect*

Bay supports USB the charger and accessory detection mechanism (EZ-Dtect). The charger detection mechanism complies with the battery-charging specification, revision 1.1. Bay also provides hardware support to detect the resistance values on the ID pin.

The Bay device detects the following resistance ranges:

- Less than 10 Ω
- Less than 1 kΩ
- 65 kΩ to 72 kΩ
- 35 kΩ to 39 kΩ
- 99.96 kΩ to 104.4 kΩ (102 kΩ ± 2%)
- 119 kΩ to 132 kΩ
- Higher than 220 kΩ
- 431.2 kΩ to 448.8 kΩ (440 kΩ ± 2%)

Bay's EZ-Dtect feature can identify a dedicated wall charger, host/hub charger, and host/hub.

Figure 3 shows the flowchart of the charger detection procedure that Bay uses. Table 1 on page 7 shows the messages that Bay may communicate over I<sup>2</sup>C to an external PMIC or processor.

Figure 3. Charger Detection Procedure

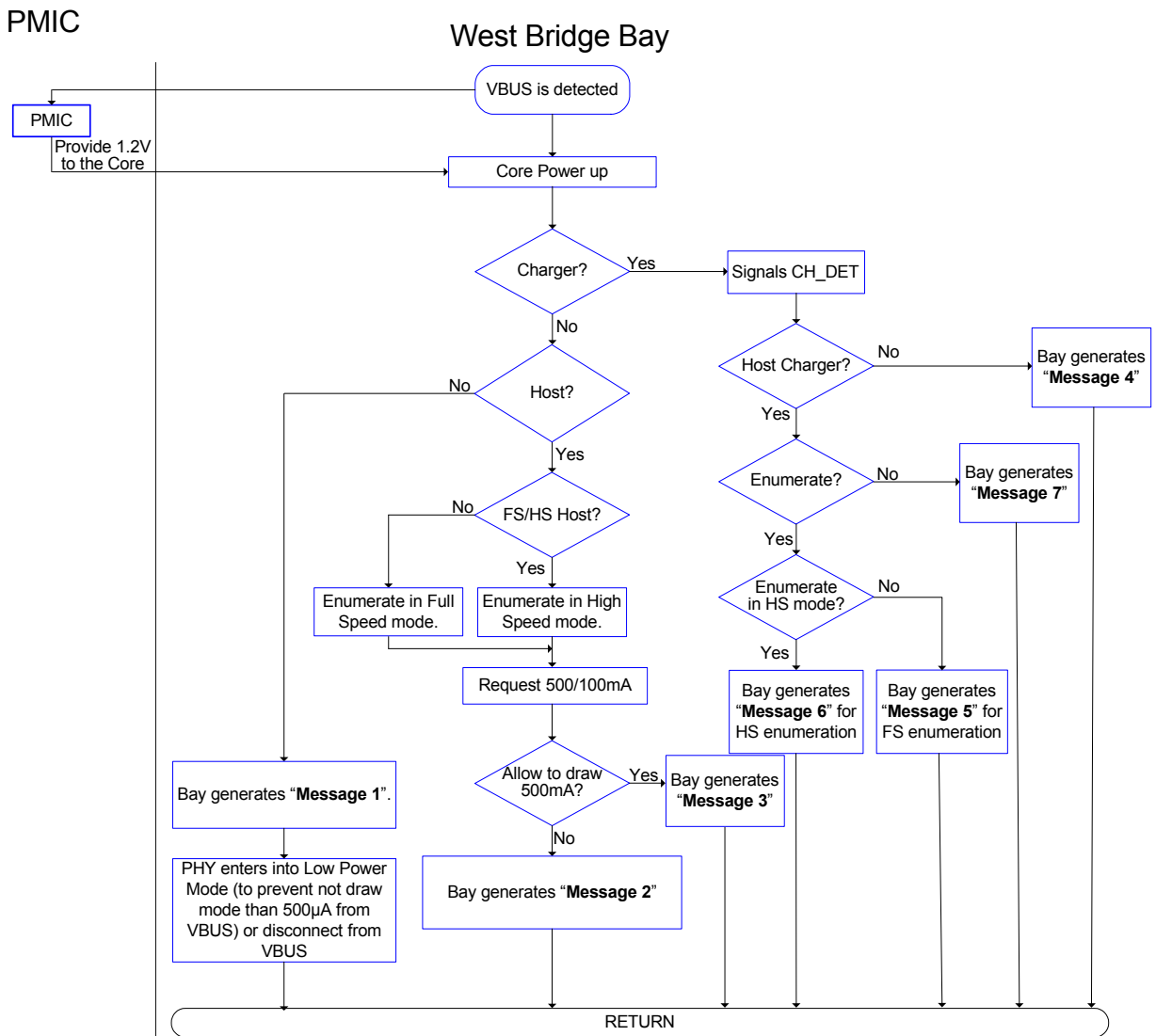

**Table 1. Charger Detect Messages**

I <sup>2</sup> C to PMIC or External Processor	Description
Message 1	Fail negotiation
Message 2	100 mA available – Host only
Message 3	500 mA available – Host only
Message 4	1.8 A available – Wall charger
Message 5	1.5 A available – Host/hub charger in FS mode
Message 6	900 mA available – Host/hub charger in HS mode
Message 7	1.5 A available – Host/hub charger

Note: Other messages can be customized in firmware.

**VBUS Overvoltage Protection**

Bay can withstand up to 6 V on the VBUS pin. In various failure scenarios, a charger may supply up to 12 V on VBUS. In this case, an external overvoltage protection (OVP) device prevents the failing charger from causing damage to the Bay device. Figure 4 shows the system application diagram with an OVP device connected to VBUS. Bay is able to draw power from either the VBATT or VBUS voltage sources. Therefore, it is also possible to leave VBUS unconnected in the system and solely use VBATT as the power source. VBATT can be connected to the system battery or a stable 3.2–6-V voltage rail from the PMIC. In this case, Bay does not perform the charger detection function and this function is supported by the external PMIC. Refer to the DC Specifications for the operating range of VBUS and VBATT.

**Figure 4. System Diagram with OVP Device For VBUS**

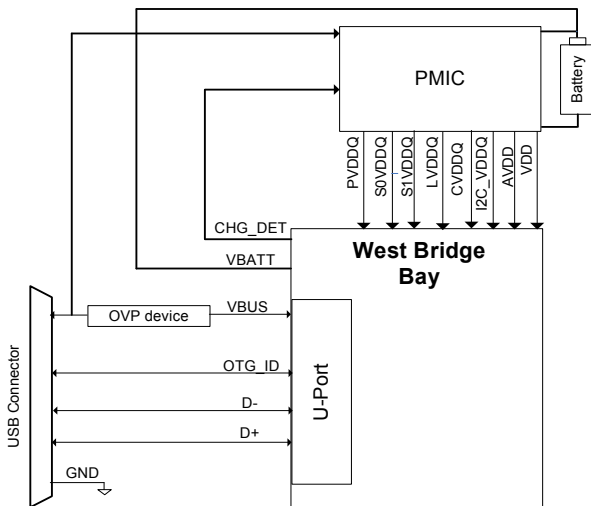

**On-The-Go (OTG)**

The West Bridge Bay OTG performs the following functions:

- Complies with OTG revision 2.0 specification
- Supports both A and B device modes and supports control, interrupt, bulk, and isochronous data transfers
- Requires an external charge pump (either standalone or integrated with a PMIC) to power VBUS in OTG A-device mode
- The target peripheral list for OTG host implementation consists of MSC- and HID-class devices. Other devices may be supported with custom firmware. Contact Cypress Applications Support for details
- Bay does not support the attach detection protocol (ADP)

**OTG Connectivity**

In the OTG mode, Bay can be configured to be an A-, B-, or dual-role device. It can connect to the following:

- Targeted USB peripheral
- SRP-capable USB peripheral
- HNP-capable USB peripheral
- OTG host
- HNP-capable host
- OTG device

The Bay device supports ACA.

**Storage Port (S-Port)**

Bay has two independent storage ports (S0-Port and S1-Port). Both storage ports comply with the following specifications:

- MMC system specification, MMCA Technical Committee, Version 4.4
- SD specification, Version 3.0
- SDIO host controller compliant with SDIO specification version 2.00 (Jan.30, 2007)

The following sections list the features that both the storage ports support.

*SD/MMC Clock Stop*

Bay supports the stop clock feature that saves power if the internal buffer becomes full, when receiving data from the SD/MMC/SDIO.

*SD\_CLK Output Clock Stop*

During the data transfer, the SD\_CLK clock can be enabled (on) or disabled (stopped) any time by the internal flow control mechanism.

You can dynamically configure the SD\_CLK output frequency using a clock divisor from a system clock. The clock choice for the divisor is user-configurable through a register. For example, the following frequencies may be configured:

- 400 kHz – For the SD/MMC card initialization
- 20 MHz – For a card with 0- to 20-MHz frequency
- 24 MHz – For a card with 0- to 26-MHz frequency
- 48 MHz – For a card with 0- to 52-MHz frequency (SD\_CLK supports 48-MHz frequency when the clock input to Bay is either 19.2 MHz or 38.4 MHz)
- 52 MHz – For a card with 0- to 52-MHz frequency (SD\_CLK supports 52-MHz frequency when the clock input to Bay is either 26 MHz or 52 MHz)
- 100 MHz – For a card with 0- to 100-MHz frequency

In the DDR mode, data is clocked on both the rising and falling edge of the SD clock. DDR clocks run up to 52 MHz.

*Card Insertion and Removal Detection*

Bay supports two-card insertion and removal detection mechanisms.

- Use of SD\_D[3] data: During system design, this signal must have an external 470-kΩ pull-down resistor connected to SD\_D[3]. SD cards have an internal 10-kΩ pull-up resistor. When the card is inserted or removed from the SD/MMC connector, the voltage level at the SD\_D[3] pin changes and triggers an interrupt to the CPU. The older generations of MMC cards do not support this card detection mechanism.

- Use of S0/S1\_INS pin: Some SD/MMC connectors facilitate a micro switch for card insertion or removal of detection. This micro switch can be connected to S0/S1\_INS. When the card is inserted or removed from the SD/MMC connector, it turns the micro switch on and off. This causes a voltage-level change at the pin that triggers the interrupt to the CPU. The card-detect micro switch polarity is assumed to be the same as the write-protect micro switch polarity. A low indicates that the card is inserted. This S0/S1\_INS pin is shared between the two S-Ports. Register configuration determines which port gets to use this pin. This pin is mapped to the S1VDDQ power domain; if S0VDDQ and S1VDDQ are at different voltage levels, this pin cannot be used as S1\_INS.

*Write Protection (WP)*

The S0\_WP/S1\_WP (SD Write Protection) on S-Port is used to connect to the WP micro switch of the SD/MMC card connector. This pin internally connects to a CPU-accessible GPIO for the firmware to detect the SD card Write Protection.

*SDIO Interrupt*

The SDIO interrupt functionality is supported as specified in the SDIO specification version 2.00 (January 30, 2007).

*SDIO Read-Wait Feature*

Bay supports the optional read-wait and suspend-resume features as defined in the SDIO specification Version 2.00 (January 30, 2007).

**Host Processor Interface (P-Port)**

A dedicated interface enables communications with a host processor. Bay supports the following P-Port interfaces.

- 16-bit asynchronous non-multiplexed SRAM
- 16-bit asynchronous address/data multiplexed SRAM
- 32-bit synchronous address/data multiplexed SRAM
- MMC slave interface compatible with MMC system specification, MMCA Technical Committee, Version 4.2 with eMMC 4.3 and 4.4 Pass-Through boot

The following sections describe these P-Port interfaces.

*Asynchronous SRAM*

This interface consists of standard asynchronous SRAM interface signals as shown in [Figure 5](#) on page 9. This interface is used to access the Bay device’s configuration registers and buffer memory. Both single-cycle and burst accesses are supported by the asynchronous interface signals.

The most significant address bit, A[7], determines if configuration registers or buffer memory are accessed. When the configuration registers are selected by asserting the A[7] address bit, the address bus bits A[6:0] point to a configuration register. When A[7] is deasserted, the buffer memory is accessed as indicated by the P-Port DMA transfer register and the transfer size is determined by the P-Port DMA transfer size register.



Application processors, with a DMA controller that uses address auto-increment during DMA transfers, can override this by connecting any higher-order address line (such as A[15]/A[23]/A[31]) of the application processor to Bay's A[7].

In the asynchronous SRAM mode, when reading from a buffer memory, Bay supports two methods of reading out the next data from the buffer: read out on the rising edge of OE# or toggle the least significant address bit A[0].

In this mode, the P-Port interface works with a 32.5-ns minimum access cycle providing an interface data rate of up to 61.5 MB per second.

Figure 5. Asynchronous SRAM Interface

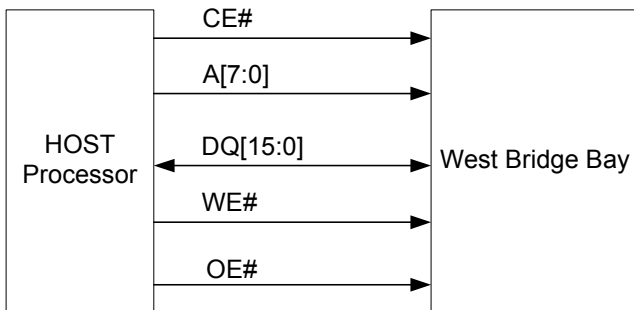

*Asynchronous Address/Data Multiplexed*

The physical ADMux memory interface consists of signals shown in Figure 6. This interface supports processors that implement a multiplexed address or data bus.

Figure 6. ADMux Memory Interface

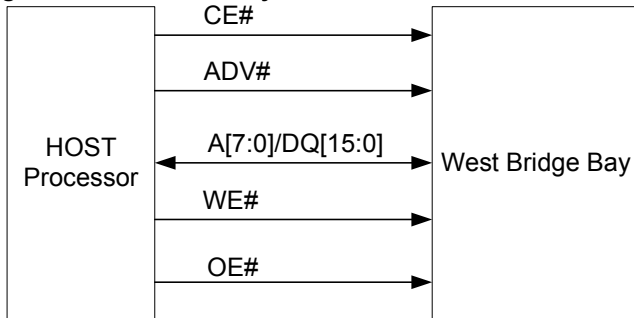

The Bay device's ADMux interface supports a 16-bit time multiplexed address/data SRAM bus.

For read operations, both CE# and OE# must be asserted.

For write operations, both CE# and WE# are asserted. OE# is "Don't Care" during a write operation (during both address and data phase of the write cycle). Input data is latched on the rising edge of WE# or CE#, whichever occurs first. The addresses must be latched prior to the write operation by toggling Address Valid (ADV#). The Address Valid (ADV#) must be asserted during the address phase of the write operation, as shown in Figure 15 on page 34.

ADV# must be LOW during the Address phase of a read/write operation. ADV# must be HIGH during the data phase of a read/write operation, as shown in Figure 14 and Figure 15 on page 34.

*Synchronous ADMux Interface*

Bay's P-Port supports a synchronous address/data multiplexed interface. This interface operates at a frequency of up to 100 MHz and supports a 16-bit data bus.

The RDY output signal from the Bay device indicates a data valid for read transfers and is acknowledged for write transfers.

Figure 7. Synchronous ADMux Interface

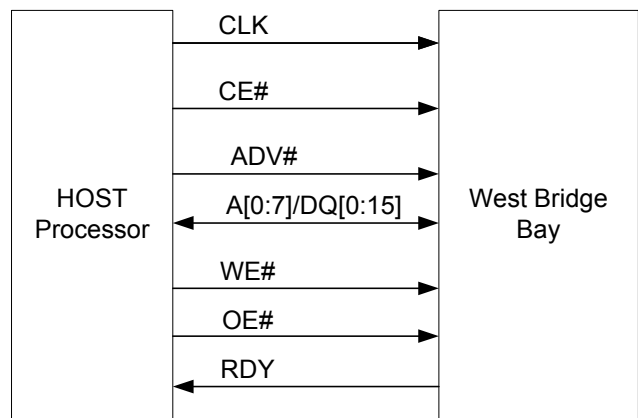

See the synchronous ADMux interface timing diagrams for details.

*Processor MMC (PMMC) Slave Interface*

Bay supports an MMC Slave interface on the P-Port called PMMC to distinguish it from the S-Port MMC interface.

Figure 8 illustrates the signals used to connect to the host processor.

The PMMC interface's GO\_IRQ\_STATE command allows West Bridge Bay to communicate asynchronous events without requiring the INT# signal. The use of the INT# signal is optional.

Figure 8. PMMC Interface Configuration

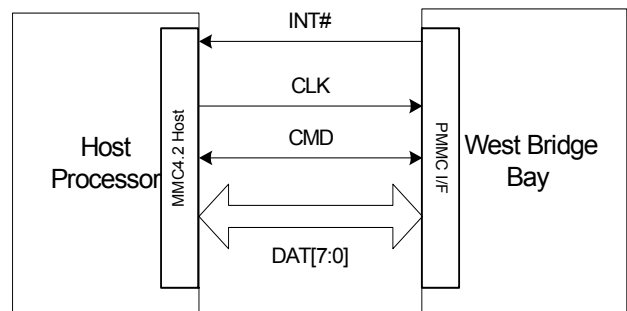

The MMC slave interface features are as follows:

- Interface operations are compatible with the MMC system specification, MMCA Technical Committee, Version 4.2
- Supports booting from an eMMC device connected to the S-Port. This feature is supported for eMMC devices operating at up to 52-MHz SDR
- Supports PMMC interface voltage ranges of 1.7 V to 1.95 V and 2.7 V to 3.6 V
- Supports open drain (both drive and receive open drain signals) on the CMD pin to allow GO\_IRQ\_STATE (CMD40) for PMMC
- Interface clock frequency range: 0 to 52 MHz
- Supports 1-bit, 4-bit, or 8-bit operation modes. This configuration is determined by the MMC initialization procedure
- Bay responds to standard initialization phase commands as specified for the MMC 4.2 slave device
- PMMC mode MMC 4.2 command classes: Class 0 (Basic), Class 2 (Block read), and Class 4 (Block write), Class 9 (I/O)

Bay supports the following PMMC commands:

- Class 0: Basic  
 CMD0, CMD1, CMD2, CMD3, CMD4, CMD6, CMD7, CMD8, CMD9, CMD10, CMD12, CMD13, CMD15, CMD19, CMD5 (wake-up support)
- Class 2: Block Read  
 CMD16, CMD17, CMD18, CMD23
- Class 4: Block Write  
 CMD16, CMD23, CMD24, CMD25
- Class 9: I-O  
 CMD39, CMD40

**Other Interfaces**

Bay supports additional low-performance peripherals that include:

- UART
- I<sup>2</sup>C
- I<sup>2</sup>S
- SPI

The SPI, UART, and I<sup>2</sup>S interfaces are multiplexed on the S1-Port. The [WLCSP Pin List](#) on page 16 shows the details.

*UART Interface*

The UART interface of Bay is intended for asynchronous serial communication with other UART devices.

The UART implementation supports full-duplex communication with a signaling format compatible with industry-standard UART. It includes the signals noted in [Table 2](#).

The UART is capable of generating a range of baud rates from 300 bps to 4608 Kbps selectable by the firmware. If flow control is enabled, then Bay's UART only transmits data when the CTS input is asserted. In addition to this, Bay's UART asserts the RTS output signal, when it is ready to receive data.

**Table 2. UART Interface Signals**

Signal	Description
TX	Output signal
RX	Input signal
CTS	Flow control
RTS	Flow control

*I<sup>2</sup>C Interface*

Bay has an I<sup>2</sup>C interface compatible with the I<sup>2</sup>C Bus Specification Revision 3. This I<sup>2</sup>C interface is only capable of operating as I<sup>2</sup>C master. Therefore, it may be used to communicate with other I<sup>2</sup>C slave devices. For example, Bay may boot from an EEPROM connected to the I<sup>2</sup>C interface, as a selectable boot option.

Bay's I<sup>2</sup>C master controller also supports the multi-master mode functionality.

The power supply for the I<sup>2</sup>C interface is I2CVDDQ, which is a separate power domain from the other serial peripherals. This gives the I<sup>2</sup>C interface the flexibility to operate at a different voltage than the other serial interfaces.

The bus frequencies supported by the I<sup>2</sup>C controller are 100 kHz, 400 kHz, and 1 MHz. When I2CVDDQ is 1.2 V, the maximum operating frequency supported is 100 kHz. When I2CVDDQ is 1.8 V, 2.5 V, or 3.3 V, the operating frequencies supported are 400 kHz and 1 MHz. The I<sup>2</sup>C controller supports the clock-stretching feature to enable slower devices to exercise flow control.

Both serial clock (SCL) and serial data (SDA) signals of the I<sup>2</sup>C interface require external pull-up resistors. The pull-up resistors must be connected to I2CVDDQ.

*I<sup>2</sup>S Interface*

Bay has an I<sup>2</sup>S port to support external audio codec devices. It functions as I<sup>2</sup>S master only as a transmitter. The I<sup>2</sup>S interface consists of four signals: clock line (I2S\_CLK), serial data line (I2S\_SD), word select line (I2S\_WS), and master system clock (I2S\_MCLK). Bay can generate the system clock as an output on I2S\_MCLK or accept an external system clock input on I2S\_MCLK.

The I<sup>2</sup>S interface supports sampling frequencies of 32 kHz, 44.1 kHz, and 48 kHz.

*SPI Interface*

Bay supports an SPI master interface on the S1-Port. The maximum operating frequency is 33 MHz.

The SPI controller supports the four modes of SPI communication (see [SPI Timing Specification](#) on page 41 for details on the modes) with a start-stop clock. The SPI controller is a single-master controller with a single automated SSN control. It supports transaction sizes ranging from 4 bits to 32 bits.

## Boot Options

Bay can load boot images from various sources, selected by the configuration of the PMODE pins. These include:

- Boot from eMMC (S0-Port)
- Boot from I<sup>2</sup>C
- Boot from asynchronous ADMux (P-Port)
- Boot from synchronous ADMux (P-Port)
- Boot from asynchronous non-multiplexed SRAM (P-Port)
- Boot from PMMC (P-Port)

USB boot can be enabled as a fallback boot option.

**Table 3. West Bridge Bay Booting Options**

PMODE[2:0]	Boot From
000	S0-Port (eMMC) On failure, USB boot is enabled
001	PMMC pass-through On failure, USB boot enabled
010	PMMC pass-through
011	PMMC_Relay (enables secure boot)
100	S0-Port (eMMC)
101	Sync ADMux (16-bit data bus)
110	PMMC legacy
111	USB Boot
00F <sup>[3]</sup>	Async SRAM (16-bit data bus)
01F <sup>[3]</sup>	Async ADMux (16-bit data bus)
10F <sup>[3]</sup>	I <sup>2</sup> C On failure, USB boot is enabled
11F <sup>[3]</sup>	I <sup>2</sup> C only
1F1 <sup>[3]</sup>	PMMC_Relay (enables secure boot) On failure USB boot is enabled
Other Combinations	Reserved

## Reset

### Hard Reset

A hard reset is initiated by asserting the RESET# pin on West Bridge Bay. The specific reset sequence and timing requirements are detailed in [Figure 23](#) on page 43 and [Figure 17](#) on page 42. All I/Os are tristated during a hard reset.

### Soft Reset

In a soft reset, the processor sets the appropriate bits in the PP\_INIT control register. There are two types of soft reset:

- CPU Reset - The CPU Program Counter is reset. Firmware does not need to be reloaded following a CPU Reset.
- Whole Device Reset - This reset is identical to hard reset. The firmware must be reloaded following a Whole Device Reset.

## Clocking

Bay allows either a crystal to be connected between the XTALIN and XTALOUT pins or an external clock to be connected at the CLKIN pin. The XTALIN, XTALOUT, CLKIN, and CLKIN\_32 pins can be left unconnected if not used.

Crystal frequency supported is 19.2 MHz, and the external clock frequencies supported are 19.2, 26, 38.4, and 52 MHz.

Bay has an on-chip oscillator circuit that uses an external 19.2-MHz (±100 ppm) crystal (when the crystal option is used). An appropriate load capacitance is required with a crystal. Refer to the specification of the crystal used to determine the appropriate load capacitance. The FSLC[2:0] pins must be configured appropriately to select the crystal- or clock-frequency option. The configuration options are shown in [Table 4](#) on page 11.

Clock inputs to Bay must meet the phase noise and jitter requirements specified in [Table 5](#) on page 12.

The input clock frequency is independent of the Bay core's clock/data rate or any of the device interfaces (including P-Port and S-Port). The internal PLL applies the appropriate clock multiply option depending on the input frequency.

**Table 4. Crystal/Clock Frequency Selection**

FSLC[2]	FSLC[1]	FSLC[0]	Crystal/Clock Frequency
0	0	0	19.2-MHz crystal
1	0	0	19.2-MHz input CLK
1	0	1	26-MHz input CLK
1	1	0	38.4-MHz input CLK
1	1	1	52-MHz input CLK

**Note**

3. F indicates Floating.

**Table 5. West Bridge Bay Input Clock Specifications**

Parameter	Description	Specification		Units
		Min	Max	
Phase Noise	100-Hz offset	–	–75	dB
	1-kHz offset	–	–104	dB
	10-kHz offset	–	–120	dB
	100-kHz offset	–	–128	dB
	1-MHz offset	–	–130	dB
Maximum frequency deviation		–	150	ppm
Duty cycle		30	70	%
Overshoot		–	3	%
Undershoot		–	–3	%
Rise time/fall time		–	3	ns

### 32-kHz Watchdog Timer Clock Input

Bay includes a watchdog timer that can be used to interrupt the CPU, automatically wake up Bay in standby mode, and reset the CPU. The watchdog timer runs off a 32-kHz clock, which may optionally be supplied from an external source on a dedicated Bay pin.

The watchdog also periodically wakes up the processor in Standby mode for polling operations, if enabled. The firmware can disable the watchdog timer.

Requirements for the optional 32-kHz clock input are listed in [Table 6](#).

**Table 6. 32-kHz Clock Input Requirement**

Parameter	Min	Max	Units
Duty cycle	40	60	%
Frequency deviation	–	±200	ppm
Rise time/Fall time	–	200	ns

### Power

Bay has the following main power supply domains:

■ **IO\_VDDQ**: This is a group of independent supply domains for digital I/Os. The voltage level on these supplies is 1.8 V to 3.3 V. Specifically, the separate I/O power domains are:

- PVDDQ: P-Port interface supply
- S0VDDQ: S0-Port supply
- S1VDDQ: S1-Port supply
- I2CVDDQ: I<sup>2</sup>C power supply (1.2 V to 3.3 V)
- LVDDQ: Low-performance peripherals power supply (UART/SPI/I<sup>2</sup>S)
- CVDDQ: Clock power supply

■ **V<sub>DD</sub>/AVDD**: Supply voltage for the logic core. The nominal supply voltage level is 1.2 V. This supplies the core logic circuits. The same supply must also be used for AVDD.

■ **VBATT**: This is the 3.2-V to 6-V battery power supply for the USB I/O and some analog circuits. This supply powers the USB transceiver through an internal voltage regulator. This supply is internally regulated to 3.3 V for the USB PHY.

■ **VBUS**: This is the 4.0-V to 6-V input from USB. When VBUS is greater than 3.7 V, it becomes the primary source of supply to the USB circuitry unless there is a software override.

**Power Modes**

Bay supports the following power modes:

- Normal mode: This is the full-functional operating mode. In this mode the internal CPU clock and the internal PLLs are enabled.

Normal operating power consumption does not exceed the sum of I<sub>CC</sub> core max and I<sub>CC</sub> USB max (refer to DC Specifications for current consumption specifications).

The I/O power supplies S0VDDQ, S1VDDQ, LVDDQ, and I2CVDDQ can be turned off when the corresponding interface is not in use. PVDDQ cannot be turned off at any time if the P-port is used in the application.

- Low-power modes (see Table 7:):
  - Suspend mode
  - Standby mode
  - Core power-down mode

**Table 7. Summary for Methods of Entry/Exit for Low Power Modes**

Power Mode	Characteristics	Method of Entry	Method of Exit
Suspend mode	<ul style="list-style-type: none"> <li>■ The power consumption in this mode does not exceed ISB<sub>suspend</sub></li> <li>■ The clocks are shut off. The PLLs are disabled</li> <li>■ All I/Os maintain their previous state</li> <li>■ Power supply for the wakeup source and core power must be retained. All other power domains can be turned on/off individually</li> <li>■ The states of the configuration registers, buffer memory, and all internal RAM are maintained</li> <li>■ All transactions must be completed before Bay enters Suspend mode (state of outstanding transactions are not preserved)</li> <li>■ The firmware resumes operation from where it was suspended (except when woken up by RESET# assertion). The program counter does not reset</li> </ul>	<ul style="list-style-type: none"> <li>■ Firmware executing on the internal ARM9 core can put West Bridge Bay into suspend mode. For example, on USB suspend condition, firmware may decide to put West Bridge Bay into suspend mode</li> <li>■ External Processor, through the use of mailbox registers, can put West Bridge Bay into suspend mode</li> </ul>	<ul style="list-style-type: none"> <li>■ D+ transitioning to LOW or HIGH</li> <li>■ D- transitioning to LOW or HIGH</li> <li>■ Impedance change on OTG_ID pin</li> <li>■ Detection of VBUS</li> <li>■ Level detect on UART_CTS (programmable polarity)</li> <li>■ P-port interface assertion of CE#</li> <li>■ Assertion of RESET#</li> <li>■ MMC CMD5 received over PMMC interface</li> <li>■ Insertion or removal of SD/MMC card detected on S0/S1_INS pin</li> <li>■ Level detect on S0_D1/S1_D1 (SDIO_INT; programmable polarity)</li> </ul>

**Table 7. Summary for Methods of Entry/Exit for Low Power Modes (continued)**

Power Mode	Characteristics	Method of Entry	Method of Exit
Standby mode	<ul style="list-style-type: none"> <li>■ The power consumption in this mode does not exceed <math>ISB_{standby}</math></li> <li>■ All configuration register settings and program/data RAM contents are preserved. However, data in the buffers or other parts of the data path, if any, is not guaranteed. Therefore, the external processor must take care that the data needed is read before putting Bay into this Standby Mode</li> <li>■ The program counter is reset after waking up from Standby</li> <li>■ GPIO pins maintain their configuration</li> <li>■ Crystal oscillator is turned off</li> <li>■ Internal PLL is turned off</li> <li>■ USB transceiver is turned off</li> <li>■ ARM9 core is powered down. Upon wakeup, the core re-starts and runs the program stored in the program/data RAM</li> <li>■ Power supply for the wakeup source and core power must be retained. All other power domains can be turned on/off individually</li> </ul>	<ul style="list-style-type: none"> <li>■ Firmware executing on the internal ARM9 core or external processor sets the appropriate register</li> <li>■ MMC CMD5 (Sleep/Awake command) over PMMC interface</li> </ul>	<ul style="list-style-type: none"> <li>■ Detection of VBUS</li> <li>■ Insertion or removal of SD/MMC card detected on S0/S1_INS pin</li> <li>■ Level detect on S0_D1/S1_D1 (SDIO_INT; programmable polarity)</li> <li>■ Level detect on UART_CTS (Programmable Polarity)</li> <li>■ P-port interface assertion of CE# in SRAM/ADMux mode</li> <li>■ P-port interface activation of MMC_CLK in PMMC mode</li> <li>■ Assertion of RESET#</li> </ul>
Core power-down mode	<ul style="list-style-type: none"> <li>■ The power consumption in this mode does not exceed <math>ISB_{core}</math></li> <li>■ Core power is turned off</li> <li>■ All buffer memory, configuration registers, and the program RAM do not maintain state. After exiting this mode, reload the firmware</li> <li>■ In this mode, all other power domains can be turned on/off individually</li> </ul>	<ul style="list-style-type: none"> <li>■ Turn off <math>V_{DD}</math></li> </ul>	<ul style="list-style-type: none"> <li>■ Reapply <math>V_{DD}</math></li> <li>■ Assertion of RESET#</li> </ul>

## Configuration Options

Configuration options are available for specific usage models. Contact Cypress Applications/Marketing for details.

## Digital I/Os

Bay provides firmware-controlled pull-up or pull-down resistors internally on all digital I/O pins. The pins can be pulled HIGH through an internal 50-kΩ resistor or can be pulled LOW through an internal 10-kΩ resistor to prevent the pins from floating. An external 470-kΩ pull-down resistor is required on SD\_D[3] when this pin is used for SD card detection. The I/O pins may have the following states:

- Tristated (High-Z)
- Weak pull-up (through internal 50 kΩ)
- Pulled down (through internal 10 kΩ)
- Hold (I/O hold its value) when in low-power modes

All unused I/Os should be pulled high by using the internal pull-up resistors. All unused outputs should be left floating. All I/Os can be driven at full-strength, three-quarter strength, half-strength, or quarter-strength. These drive strengths are configured based on each interface.

## EMI

Bay meets the EMI requirements outlined by FCC 15B (USA) and EN55022 (Europe) for consumer electronics. It can also tolerate reasonable EMI, conducted by the aggressor, outlined by these specifications and continue to function as expected.

## System-level ESD

Bay has additional ESD protection on the D+, D-, OTG\_ID, VBUS, GND pins on the U-port and the S1\_D[0:7], S1\_CMD, S1\_CLK, S1\_WP and MMC1RST\_OUT pins on the S1-Port. The ESD protection levels provided on these ports are:

- ± 2.2-KV human body model (HBM) based on JESD22-A114 specification
- ± 6-KV contact discharge and ± 8-KV air gap discharge based on IEC61000-4-2 level 3A
- ± 8 KV contact discharge and ± 15 KV air gap discharge based on IEC61000-4-2 level 4C

This protection ensures that the device continues to function after ESD events up to the levels stated.

The S0/S1\_INS pin has up to ± 2.2-KV HBM internal ESD protection.

Figure 9. WLCSP Ball Map (Bottom View)<sup>[4]</sup>

	12	11	10	9	8	7	6	5	4	3	2	1
A	VSS	VSS	NC	NC	NC	FSLC[0]	AVSS	AVDD	DP	U2AFEVSSQ	DM	VDD
B	L_GPIO[55]	LVDDQ	NC	R_USB3	NC	FSLC[2]	XTALIN	XTALOUT	SWDP	R_USB2	SWDM	VDD
C	L_GPIO[56]	S1VDDQ	VDD	VSS	VDD	CVDDQ	CLKIN_32	CLKIN	U2PLLVSQ	OTG_ID	TDO	TRST#
D	S1_GPIO[49]	S1_GPIO[50]	L_GPIO[53]	L_GPIO[54]	RESET#	VDD	I2C_GPIO[58]	TMS	I2CVDDQ	TCK	I2C_GPIO[59]	VSS
E	L_GPIO[57]	S1_GPIO[48]	S1_GPIO[51]	S1_GPIO[52]	I2C_O[60]	VSS	VSS	VSS	VSS	P_GPIO[3]	VBATT	VBUS
F	VSS	S1_GPIO[46]	S1_GPIO[47]	FSLC[1]	TDI	VDD	VDD	VDD	VDD	P_GPIO[4]	P_GPIO[1]	P_GPIO[0]
G	S0VDDQ	S0_GPIO[43]	S0_GPIO[44]	S0_GPIO[45]	VSS	VSS	VDD	VSS	P_GPIO[9]	P_GPIO[7]	P_GPIO[6]	P_GPIO[2]
H	VSS	S0_GPIO[40]	S0_GPIO[41]	S0_GPIO[42]	S0_GPIO[39]	VSS	P_GPIO[20]	P_GPIO[18]	P_GPIO[14]	P_GPIO[12]	P_GPIO[8]	PVDDQ
J	S0VDDQ	S0_GPIO[38]	S0_GPIO[37]	S0_GPIO[36]	P_GPIO[31]	P_GPIO[27]	P_GPIO[25]	P_GPIO[22]	P_GPIO[19]	P_GPIO[15]	P_GPIO[10]	P_GPIO[5]
K	S0_GPIO[35]	S0_GPIO[34]	S0_GPIO[33]	P_GPIO[32]	P_GPIO[28]	P_GPIO[26]	P_GPIO[16]	P_GPIO[21]	INT#	P_GPIO[24]	P_GPIO[11]	VSS
L	VDD	VSS	VDD	P_GPIO[30]	P_GPIO[29]	PVDDQ	P_GPIO[23]	VSS	PVDDQ	P_GPIO[17]	P_GPIO[13]	VSS

Figure 10. BGA Ball Map

	1	2	3	4	5	6	7	8	9	10	11
A	VSS	VDD	NC	NC	NC	NC	AVDD	VSS	DP	DM	NC
B	LVDDQ	FSLC[0]	NC	FSLC[1]	VDD	CVDDQ	AVSS	VSS	VSS	VDD	TRST#
C	L_GPIO[54]	L_GPIO[55]	VDD	L_GPIO[57]	RESET#	XTALIN	XTALOUT	R_USB2	OTG_ID	TDO	I2CVDDQ
D	S1_GPIO[50]	S1_GPIO[51]	S1_GPIO[52]	L_GPIO[53]	L_GPIO[56]	CLKIN_32	CLKIN	VSS	I2C_GPIO[58]	I2C_GPIO[59]	O[60]
E	S1_GPIO[47]	VSS	S1VDDQ	S1_GPIO[49]	S1_GPIO[48]	FSLC[2]	TDI	TMS	VDD	VBATT	VBUS
F	S0VDDQ	S0_GPIO[45]	S0_GPIO[44]	S0_GPIO[41]	S1_GPIO[46]	TCK	P_GPIO[2]	P_GPIO[5]	P_GPIO[1]	P_GPIO[0]	VDD
G	VSS	S0_GPIO[42]	S0_GPIO[43]	P_GPIO[30]	P_GPIO[25]	P_GPIO[22]	P_GPIO[21]	P_GPIO[15]	P_GPIO[4]	P_GPIO[3]	VSS
H	VDD	S0_GPIO[39]	S0_GPIO[40]	P_GPIO[31]	P_GPIO[29]	P_GPIO[26]	P_GPIO[20]	P_GPIO[24]	P_GPIO[7]	P_GPIO[6]	PVDDQ
J	S0_GPIO[38]	S0_GPIO[36]	S0_GPIO[37]	S0_GPIO[34]	P_GPIO[28]	P_GPIO[16]	P_GPIO[19]	P_GPIO[14]	P_GPIO[9]	P_GPIO[8]	VDD
K	S0_GPIO[35]	S0_GPIO[33]	VSS	VSS	P_GPIO[27]	P_GPIO[23]	P_GPIO[18]	P_GPIO[17]	P_GPIO[13]	P_GPIO[12]	P_GPIO[10]
L	VSS	VSS	VSS	P_GPIO[32]	VDD	VSS	VDD	INT#	PVDDQ	P_GPIO[11]	VSS

**Note**

- 4. No ball is populated at location A9.

## Pin Description

Table 8. WLCSP Pin List

Pin	Power Domain	I/O	Name	Description			
				P-Port			
				Async SRAM	Async ADMux	Sync ADMux	PMMC
F1	PVDDQ	I/O	P_GPIO[0]	DQ[0]	DQ[0]/A[0]	DQ[0]/A[0]	MMC_D0
F2	PVDDQ	I/O	P_GPIO[1]	DQ[1]	DQ[1]/A[1]	DQ[1]/A[1]	MMC_D1
G1	PVDDQ	I/O	P_GPIO[2]	DQ[2]	DQ[2]/A[2]	DQ[2]/A[2]	MMC_D2
E3	PVDDQ	I/O	P_GPIO[3]	DQ[3]	DQ[3]/A[3]	DQ[3]/A[3]	MMC_D3
F3	PVDDQ	I/O	P_GPIO[4]	DQ[4]	DQ[4]/A[4]	DQ[4]/A[4]	MMC_D4
J1	PVDDQ	I/O	P_GPIO[5]	DQ[5]	DQ[5]/A[5]	DQ[5]/A[5]	MMC_D5
G2	PVDDQ	I/O	P_GPIO[6]	DQ[6]	DQ[6]/A[6]	DQ[6]/A[6]	MMC_D6
G3	PVDDQ	I/O	P_GPIO[7]	DQ[7]	DQ[7]/A[7]	DQ[7]/A[7]	MMC_D7
H2	PVDDQ	I/O	P_GPIO[8]	DQ[8]	DQ[8]/A[8]	DQ[8]/A[8]	GPIO
G4	PVDDQ	I/O	P_GPIO[9]	DQ[9]	DQ[9]/A[9]	DQ[9]/A[9]	GPIO
J2	PVDDQ	I/O	P_GPIO[10]	DQ[10]	DQ[10]/A[10]	DQ[10]/A[10]	GPIO
K2	PVDDQ	I/O	P_GPIO[11]	DQ[11]	DQ[11]/A[11]	DQ[11]/A[11]	GPIO
H3	PVDDQ	I/O	P_GPIO[12]	DQ[12]	DQ[12]/A[12]	DQ[12]/A[12]	GPIO
L2	PVDDQ	I/O	P_GPIO[13]	DQ[13]	DQ[13]/A[13]	DQ[13]/A[13]	GPIO
H4	PVDDQ	I/O	P_GPIO[14]	DQ[14]	DQ[14]/A[14]	DQ[14]/A[14]	GPIO
J3	PVDDQ	I/O	P_GPIO[15]	DQ[15]	DQ[15]/A[15]	DQ[15]/A[15]	GPIO
K6	PVDDQ	I/O	P_GPIO[16]	CLK	CLK	CLK	MMC_CLK
L3	PVDDQ	I/O	P_GPIO[17]	CE#	CE#	CE#	GPIO
H5	PVDDQ	I/O	P_GPIO[18]	WE#	WE#	WE#	MMC_CMD
J4	PVDDQ	I/O	P_GPIO[19]	OE#	OE#	OE#	GPIO
H6	PVDDQ	I/O	P_GPIO[20]	DACK#	DACK#	DACK#	GPIO
K5	PVDDQ	I/O	P_GPIO[21]	DRQ#	DRQ#	DRQ#	GPIO
J5	PVDDQ	I/O	P_GPIO[22]	A[7]	GPIO	GPIO	GPIO
L6	PVDDQ	I/O	P_GPIO[23]	A[6]	GPIO	RDY	GPIO
K3	PVDDQ	I/O	P_GPIO[24]	A[5]	GPIO	GPIO	GPIO
J6	PVDDQ	I/O	P_GPIO[25]	A[4]	GPIO	GPIO	GPIO
K7	PVDDQ	I/O	P_GPIO[26]	A[3]	GPIO	GPIO	GPIO
J7	PVDDQ	I/O	P_GPIO[27]	A[2]	ADV#	ADV#	GPIO



Table 8. WLCSP Pin List (continued)

Pin	Power Domain	I/O	Name	Description							
K8	PVDDQ	I/O	P_GPIO[28]	A[1]	GPIO	GPIO	UART_RX				
L8	PVDDQ	I/O	P_GPIO[29]	A[0]	GPIO	GPIO	UART_TX				
L9	PVDDQ	I/O	P_GPIO[30]	PMODE[0]	PMODE[0]	PMODE[0]	PMODE[0]				
J8	PVDDQ	I/O	P_GPIO[31]	PMODE[1]	PMODE[1]	PMODE[1]	PMODE[1]				
K9	PVDDQ	I/O	P_GPIO[32]	PMODE[2]	PMODE[2]	PMODE[2]	PMODE[2]				
K4	PVDDQ	O	INT#	INT#	INT#	INT#	INT#				
D8	CVDDQ	I	RESET#	RESET#	RESET#	RESET#	RESET#				
				<b>S0-Port</b>							
				<b>8b MMC</b>	<b>SD+GPIO</b>			<b>GPIO</b>			
K10	S0VDDQ	I/O	S0_GPIO[33]	S0_SD0	S0_SD0			GPIO			
K11	S0VDDQ	I/O	S0_GPIO[34]	S0_SD1	S0_SD1			GPIO			
K12	S0VDDQ	I/O	S0_GPIO[35]	S0_SD2	S0_SD2			GPIO			
J9	S0VDDQ	I/O	S0_GPIO[36]	S0_SD3	S0_SD3			GPIO			
J10	S0VDDQ	I/O	S0_GPIO[37]	S0_SD4	GPIO			GPIO			
J11	S0VDDQ	I/O	S0_GPIO[38]	S0_SD5	GPIO			GPIO			
H8	S0VDDQ	I/O	S0_GPIO[39]	S0_SD6	GPIO			GPIO			
H11	S0VDDQ	I/O	S0_GPIO[40]	S0_SD7	GPIO			GPIO			
H10	S0VDDQ	I/O	S0_GPIO[41]	S0_CMD	S0_CMD			GPIO			
H9	S0VDDQ	I/O	S0_GPIO[42]	S0_CLK	S0_CLK			GPIO			
G11	S0VDDQ	I/O	S0_GPIO[43]	S0_WP	S0_WP			GPIO			
G10	S0VDDQ	I/O	S0_GPIO[44]	S0S1_INS	S0S1_INS			GPIO			
G9	S0VDDQ	I/O	S0_GPIO[45]	MMC0_RST_OUT	GPIO			GPIO			
				<b>S1-Port</b>							
				<b>8b MMC</b>	<b>SD+UART</b>	<b>SD+SPI</b>	<b>SD+GPIO</b>	<b>GPIO</b>	<b>GPIO+ UART+SPI</b>	<b>4b SD+I2S</b>	<b>UART+ SPI+I2S</b>
F11	S1VDDQ	I/O	S1_GPIO[46]	S1_SD0	S1_SD0	S1_SD0	S1_SD0	GPIO	GPIO	S1_SD0	UART_RTS
F10	S1VDDQ	I/O	S1_GPIO[47]	S1_SD1	S1_SD1	S1_SD1	S1_SD1	GPIO	GPIO	S1_SD1	UART_CTS
E11	S1VDDQ	I/O	S1_GPIO[48]	S1_SD2	S1_SD2	S1_SD2	S1_SD2	GPIO	GPIO	S1_SD2	UART_TX
D12	S1VDDQ	I/O	S1_GPIO[49]	S1_SD3	S1_SD3	S1_SD3	S1_SD3	GPIO	GPIO	S1_SD3	UART_RX
D11	S1VDDQ	I/O	S1_GPIO[50]	S1_CMD	S1_CMD	S1_CMD	S1_CMD	GPIO	I2S_CLK	S1_CMD	I2S_CLK
E10	S1VDDQ	I/O	S1_GPIO[51]	S1_CLK	S1_CLK	S1_CLK	S1_CLK	GPIO	I2S_SD	S1_CLK	I2S_SD
E9	S1VDDQ	I/O	S1_GPIO[52]	S1_WP	S1_WP	S1_WP	S1_WP	GPIO	I2S_WS	S1_WP	I2S_WS

Table 8. WLCSP Pin List (continued)

Pin	Power Domain	I/O	Name	Description							
D10	LVDDQ	I/O	L_GPIO[53]	S1_SD4	UART_RTS	SPI_SCK	GPIO	GPIO	UART_RTS	GPIO	SPI_SCK
D9	LVDDQ	I/O	L_GPIO[54]	S1_SD5	UART_CTS	SPI_SSN	GPIO	GPIO	UART_CTS	I2S_CLK	SPI_SSN
B12	LVDDQ	I/O	L_GPIO[55]	S1_SD6	UART_TX	SPI_MISO	GPIO	GPIO	UART_TX	I2S_SD	SPI_MISO
C12	LVDDQ	I/O	L_GPIO[56]	S1_SD7	UART_RX	SPI_MOSI	GPIO	GPIO	UART_RX	I2S_WS	SPI_MOSI
E12	LVDDQ	I/O	L_GPIO[57]	MMC1_RST_OUT	GPIO	GPIO	GPIO	GPIO	I2S_MCLK	I2S_MCLK	I2S_MCLK
<b>U-Port</b>											
C3	VBUS/ VBATT	I	OTG_ID	USB OTG Identification							
A10		I	NC	No Connect							
B10		I	NC	No Connect							
A8		O	NC	No Connect							
B8		O	NC	No Connect							
A4	VBUS/VBATT	I/O	DP	USB (HS/FS) Data Plus							
A2	VBUS/VBATT	I/O	DM	USB (HS/FS) Data Minus							
B4	VBUS/VBATT	I/O	SWDP	USB (HS/FS) Switch Interface Data Plus							
B2	VBUS/VBATT	I/O	SWDM	USB (HS/FS) Switch Interface Data Minus							
<b>Crystal/Clocks</b>											
A7	CVDDQ	I	FSLC[0]	Frequency Select 0							
B6	AVDD	I/O	XTALIN	Crystal Oscillator Input							
B5	AVDD	I/O	XTALOUT	Crystal Oscillator Output							
F9	CVDDQ	I	FSLC[1]	Frequency Select 1							
B7	CVDDQ	I	FSLC[2]	Frequency Select 2							
C5	CVDDQ	I	CLKIN	External Clock Input							
C6	CVDDQ	I	CLKIN_32	32.76-kHz Clock Input for Watchdog Timer							
<b>Other</b>											
D6	I2CVDDQ	I/O	I <sup>2</sup> C_GPIO[58]	Serial Clock (SCL) for I <sup>2</sup> C Bus Interface							
D2	I2CVDDQ	I/O	I <sup>2</sup> C_GPIO[59]	Serial Data (SDA) for I <sup>2</sup> C Bus Interface							
F8	I2CVDDQ	I	TDI	Test Data In (TDI) for JTAG Interface							
C2	I2CVDDQ	O	TDO	Test Data Out (TDO) for JTAG Interface							
C1	I2CVDDQ	O	TRST#	Test Reset (TRST) for JTAG Interface							
D5	I2CVDDQ	O	TMS	Test Mode Select (TMS) for JTAG Interface							
D3	I2CVDDQ	O	TCK	Test Clock (TCK) for JTAG Interface							

Table 8. WLCSP Pin List (continued)

Pin	Power Domain	I/O	Name	Description
E8	I2CVDDQ	O	O[60]	Charger Detect Output
				<b>Power</b>
E2		PWR	VBATT	USB Supply Voltage Input
B1		PWR	VDD	E-fuse Program Supply
A1		PWR	VDD	E-fuse Program Supply
C9		PWR	VSS	GND
E1		PWR	VBUS	USB Supply Voltage Input
C4		PWR	U2PLLVSSQ	USB2 Regulator GND
H1		PWR	PVDDQ	P-Port Supply Voltage Input
K1		PWR	VSS	GND
L4		PWR	PVDDQ	P-Port Supply Voltage Input
L5		PWR	VSS	GND
L7		PWR	PVDDQ	P-Port Supply Voltage Input
L1		PWR	VSS	GND
J12		PWR	S0VDDQ	S0-Port Supply Voltage Input
H12		PWR	VSS	GND
G12		PWR	S0VDDQ	S0- Port Supply Voltage Input
C11		PWR	S1VDDQ	S1-Port Supply Voltage Input
F12		PWR	VSS	GND
B11		PWR	LVDDQ	Low-Performance Peripherals Supply Voltage Input
A11		PWR	VSS	GND
A12		PWR	VSS	GND
C7		PWR	CVDDQ	Clock-Supply Voltage Input
C8		PWR	VDD	Core-Supply Voltage Input
C10		PWR	VDD	Core-Supply Voltage Input
D4		PWR	I2CVDDQ	I2C- and JTAG-Supply Voltage Input
A3		PWR	U2AFEVSSQ	GND
A5		PWR	AVDD	Analog-Supply Voltage Input
A6		PWR	AVSS	Analog GND
F4		PWR	VDD	Core-Supply Voltage Input
D1		PWR	VSS	GND
F5		PWR	VDD	Core-Supply Voltage Input

Table 8. WLCSP Pin List (continued)

Pin	Power Domain	I/O	Name	Description
E4		PWR	VSS	GND
F6		PWR	VDD	Core-Supply Voltage Input
E5		PWR	VSS	GND
F7		PWR	VDD	Core-Supply Voltage Input
E6		PWR	VSS	GND
D7		PWR	VDD	Core-Supply Voltage Input
E7		PWR	VSS	GND
G6		PWR	VDD	Core-Supply Voltage Input
L10		PWR	VDD	Core-Supply Voltage Input
L12		PWR	VDD	Core-Supply Voltage Input
H7		PWR	VSS	GND
G7		PWR	VSS	GND
L11		PWR	VSS	GND
G8		PWR	VSS	GND
G5		PWR	VSS	GND
B3	VBATT/ VBUS	I/O	R_USB2	Precision Resistor for USB 2.0 (Connect a 6.04-kΩ ± 1% resistor between this pin and GND)
B9		I/O	NC	No Connect

Table 9. BGA Pin List

Pin	Power Domain	I/O	Name	Description			
				P-Port			
				Async SRAM	Async ADMux	Sync ADMux	PMMC
F10	PVDDQ	I/O	P_GPIO[0]	DQ[0]	DQ[0]/A[0]	DQ[0]/A[0]	MMC_D0
F9	PVDDQ	I/O	P_GPIO[1]	DQ[1]	DQ[1]/A[1]	DQ[1]/A[1]	MMC_D1
F7	PVDDQ	I/O	P_GPIO[2]	DQ[2]	DQ[2]/A[2]	DQ[2]/A[2]	MMC_D2
G10	PVDDQ	I/O	P_GPIO[3]	DQ[3]	DQ[3]/A[3]	DQ[3]/A[3]	MMC_D3
G9	PVDDQ	I/O	P_GPIO[4]	DQ[4]	DQ[4]/A[4]	DQ[4]/A[4]	MMC_D4
F8	PVDDQ	I/O	P_GPIO[5]	DQ[5]	DQ[5]/A[5]	DQ[5]/A[5]	MMC_D5
H10	PVDDQ	I/O	P_GPIO[6]	DQ[6]	DQ[6]/A[6]	DQ[6]/A[6]	MMC_D6

Table 9. BGA Pin List

Pin	Power Domain	I/O	Name	Description			
H9	PVDDQ	I/O	P_GPIO[7]	DQ[7]	DQ[7]/A[7]	DQ[7]/A[7]	MMC_D7
J10	PVDDQ	I/O	P_GPIO[8]	DQ[8]	DQ[8]/A[8]	DQ[8]/A[8]	GPIO
J9	PVDDQ	I/O	P_GPIO[9]	DQ[9]	DQ[9]/A[9]	DQ[9]/A[9]	GPIO
K11	PVDDQ	I/O	P_GPIO[10]	DQ[10]	DQ[10]/A[10]	DQ[10]/A[10]	GPIO
L10	PVDDQ	I/O	P_GPIO[11]	DQ[11]	DQ[11]/A[11]	DQ[11]/A[11]	GPIO
K10	PVDDQ	I/O	P_GPIO[12]	DQ[12]	DQ[12]/A[12]	DQ[12]/A[12]	GPIO
K9	PVDDQ	I/O	P_GPIO[13]	DQ[13]	DQ[13]/A[13]	DQ[13]/A[13]	GPIO
J8	PVDDQ	I/O	P_GPIO[14]	DQ[14]	DQ[14]/A[14]	DQ[14]/A[14]	GPIO
G8	PVDDQ	I/O	P_GPIO[15]	DQ[15]	DQ[15]/A[15]	DQ[15]/A[15]	GPIO
J6	PVDDQ	I/O	P_GPIO[16]	CLK	CLK	CLK	MMC_CLK
K8	PVDDQ	I/O	P_GPIO[17]	CE#	CE#	CE#	GPIO
K7	PVDDQ	I/O	P_GPIO[18]	WE#	WE#	WE#	MMC_CMD
J7	PVDDQ	I/O	P_GPIO[19]	OE#	OE#	OE#	GPIO
H7	PVDDQ	I/O	P_GPIO[20]	DACK#	DACK#	DACK#	GPIO
G7	PVDDQ	I/O	P_GPIO[21]	DRQ#	DRQ#	DRQ#	GPIO
G6	PVDDQ	I/O	P_GPIO[22]	A[7]	GPIO	GPIO	GPIO
K6	PVDDQ	I/O	P_GPIO[23]	A[6]	GPIO	RDY	GPIO
H8	PVDDQ	I/O	P_GPIO[24]	A[5]	GPIO	GPIO	GPIO
G5	PVDDQ	I/O	P_GPIO[25]	A[4]	GPIO	GPIO	GPIO
H6	PVDDQ	I/O	P_GPIO[26]	A[3]	GPIO	GPIO	GPIO
K5	PVDDQ	I/O	P_GPIO[27]	A[2]	ADV#	ADV#	GPIO
J5	PVDDQ	I/O	P_GPIO[28]	A[1]	GPIO	GPIO	UART_RX
H5	PVDDQ	I/O	P_GPIO[29]	A[0]	GPIO	GPIO	UART_TX
G4	PVDDQ	I/O	P_GPIO[30]	PMODE[0]	PMODE[0]	PMODE[0]	PMODE[0]
H4	PVDDQ	I/O	P_GPIO[31]	PMODE[1]	PMODE[1]	PMODE[1]	PMODE[1]
L4	PVDDQ	I/O	P_GPIO[32]	PMODE[2]	PMODE[2]	PMODE[2]	PMODE[2]
L8	PVDDQ	I/O	INT#	INT#	INT#	INT#	INT#
C5	CVDDQ	I	RESET#	RESET#	RESET#	RESET#	RESET#
				S0-Port			
				8b MMC	SD+GPIO		GPIO
K2	S0VDDQ	I/O	S0_GPIO[33]	S0_SD0	S0_SD0		GPIO
J4	S0VDDQ	I/O	S0_GPIO[34]	S0_SD1	S0_SD1		GPIO

Table 9. BGA Pin List

Pin	Power Domain	I/O	Name	Description							
K1	S0VDDQ	I/O	S0_GPIO[35]	S0_SD2		S0_SD2		GPIO			
J2	S0VDDQ	I/O	S0_GPIO[36]	S0_SD3		S0_SD3		GPIO			
J3	S0VDDQ	I/O	S0_GPIO[37]	S0_SD4		GPIO		GPIO			
J1	S0VDDQ	I/O	S0_GPIO[38]	S0_SD5		GPIO		GPIO			
H2	S0VDDQ	I/O	S0_GPIO[39]	S0_SD6		GPIO		GPIO			
H3	S0VDDQ	I/O	S0_GPIO[40]	S0_SD7		GPIO		GPIO			
F4	S0VDDQ	I/O	S0_GPIO[41]	S0_CMD		S0_CMD		GPIO			
G2	S0VDDQ	I/O	S0_GPIO[42]	S0_CLK		S0_CLK		GPIO			
G3	S0VDDQ	I/O	S0_GPIO[43]	S0_WP		S0_WP		GPIO			
F3	S0VDDQ	I/O	S0_GPIO[44]	S0S1_INS				S0S1_INS			
F2	S0VDDQ	I/O	S0_GPIO[45]	MMC0_RST_OUT				GPIO		GPIO	
				S1-Port							
				8b MMC	SD+UART	SD+SPI	SD+GPIO	GPIO	GPIO+UART+I2S	SD+I2S	UART+SPI+I2S
F5	S1VDDQ	I/O	S1_GPIO[46]	S1_SD0	S1_SD0	S1_SD0	S1_SD0	GPIO	GPIO	S1_SD0	UART_RTS
E1	S1VDDQ	I/O	S1_GPIO[47]	S1_SD1	S1_SD1	S1_SD1	S1_SD1	GPIO	GPIO	S1_SD1	UART_CTS
E5	S1VDDQ	I/O	S1_GPIO[48]	S1_SD2	S1_SD2	S1_SD2	S1_SD2	GPIO	GPIO	S1_SD2	UART_TX
E4	S1VDDQ	I/O	S1_GPIO[49]	S1_SD3	S1_SD3	S1_SD3	S1_SD3	GPIO	GPIO	S1_SD3	UART_RX
D1	S1VDDQ	I/O	S1_GPIO[50]	S1_CMD	S1_CMD	S1_CMD	S1_CMD	GPIO	I2S_CLK	S1_CMD	I2S_CLK
D2	S1VDDQ	I/O	S1_GPIO[51]	S1_CLK	S1_CLK	S1_CLK	S1_CLK	GPIO	I2S_SD	S1_CLK	I2S_SD
D3	S1VDDQ	I/O	S1_GPIO[52]	S1_WP	S1_WP	S1_WP	S1_WP	GPIO	I2S_WS	S1_WP	I2S_WS
D4	LVDDQ	I/O	L_GPIO[53]	S1_SD4	UART_RTS	SPI_SCK	GPIO	GPIO	UART_RTS	GPIO	SPI_SCK
C1	LVDDQ	I/O	L_GPIO[54]	S1_SD5	UART_CTS	SPI_SSN	GPIO	GPIO	UART_CTS	I2S_CLK	SPI_SSN
C2	LVDDQ	I/O	L_GPIO[55]	S1_SD6	UART_TX	SPI_MISO	GPIO	GPIO	UART_TX	I2S_SD	SPI_MISO
D5	LVDDQ	I/O	L_GPIO[56]	S1_SD7	UART_RX	SPI_MOSI	GPIO	GPIO	UART_RX	I2S_WS	SPI_MOSI

Table 9. BGA Pin List

Pin	Power Domain	I/O	Name	Description							
C4	LVDDQ	I/O	L_GPIO[57]	MMC1_R ST_OUT	GPIO	GPIO	GPIO	GPIO	I2S_MCLK	I2S_MCLK	I2S_MCLK
				USB Port (VBATT/VBUS Power Domain)							
C9	VBUS/VBATT	I	OTG_ID	OTG_ID							
				USB Port (VBATT/VBUS Power Domain)							
A3		I	NC	No Connect							
A4		I	NC	No Connect							
A6		O	NC	No Connect							
A5		O	NC	No Connect							
A9	VBUS/VBATT	I/O	DP	D+							
A10	VBUS/VBATT	I/O	DM	D-							
A11			NC	Do Not Connect							
				Crystal/Clocks (CVDDQ Power Domain)							
B2	CVDDQ	I	FSLC[0]	FSLC[0]							
C6	AVDD	I/O	XTALIN	XTALIN							
C7	AVDD	I/O	XTALOUT	XTALOUT							
B4	CVDDQ	I	FSLC[1]	FSLC[1]							
E6	CVDDQ	I	FSLC[2]	FSLC[2]							
D7	CVDDQ	I	CLKIN	CLKIN							
D6	CVDDQ	I	CLKIN_32	CLKIN_32							
				I2C and JTAG (I2CVDDQ Power Domain)							
D9	I2CVDDQ	I/O	I2C_GPIO[58]	I <sup>2</sup> C_SCL							
D10	I2CVDDQ	I/O	I2C_GPIO[59]	I <sup>2</sup> C_SDA							
E7	I2CVDDQ	I	TDI	TDI							
C10	I2CVDDQ	O	TDO	TDO							
B11	I2CVDDQ	I	TRST#	TRST#							
E8	I2CVDDQ	I	TMS	TMS							
F6	I2CVDDQ	I	TCK	TCK							
D11	I2CVDDQ	O	O[60]	Charger detect output							
				Power							

**Table 9. BGA Pin List**

Pin	Power Domain	I/O	Name	Description
E10		PWR	VBATT	
B10		PWR	VDD	
A1		PWR	VSS	
E11		PWR	VBUS	
D8		PWR	VSS	
H11		PWR	PVDDQ	
E2		PWR	VSS	
L9		PWR	PVDDQ	
G1		PWR	VSS	
F1		PWR	S0VDDQ	
G11		PWR	VSS	
E3		PWR	S1VDDQ	
L1		PWR	VSS	
B1		PWR	LVDDQ	
L6		PWR	VSS	
B6		PWR	CVDDQ	
B5		PWR	VDD	
A2		PWR	VDD	
C11		PWR	I2CVDDQ	
L11		PWR	VSS	
A7		PWR	AVDD	
B7		PWR	AVSS	
C3		PWR	VDD	
B8		PWR	VSS	
E9		PWR	VDD	
B9		PWR	VSS	
F11		PWR	VDD	
H1		PWR	VDD	
L7		PWR	VDD	
J11		PWR	VDD	
L5		PWR	VDD	
K4		PWR	VSS	



**Table 9. BGA Pin List**

Pin	Power Domain	I/O	Name	Description
L3		PWR	VSS	
K3		PWR	VSS	
L2		PWR	VSS	
A8		PWR	VSS	
				Precision Resistors
C8	VBUS/VBATT	I/O	R_usb2	Precision Resistor for USB 2.0 (Connect a 6.04 k $\Omega$ $\pm$ 1% resistor between this pin and GND)
B3		I/O	NC	No Connect

### Absolute Maximum Ratings

Exceeding maximum ratings may shorten the useful life of the device.

- Storage temperature..... -65 °C to +150 °C
- Ambient temperature with power supplied (Industrial)..... -40 °C to +85 °C
- Supply voltage to ground potential  
V<sub>DD</sub>, A<sub>VDDQ</sub>..... 1.25 V
- P<sub>VDDQ</sub>, S0<sub>VDDQ</sub>, S1<sub>VDDQ</sub>, L<sub>VDDQ</sub>,  
C<sub>VDDQ</sub>, I<sup>2</sup>C<sub>VDDQ</sub>..... 3.6 V
- DC input voltage to any input pin..... VCC + 0.3
- DC voltage applied to outputs in HIGH-Z state..... VCC + 0.3  
(VCC is the corresponding IO voltage)

Static discharge voltage ESD protection levels:

- ± 2.2 KV HBM based on JESD22-A114
- Additional ESD protection levels on D+, D-, OTG\_ID, V<sub>BUS</sub>, GND pins U-port and S1\_D[0:7], S1\_CMD, S1\_CLK, S1\_WP, MMC1RST\_OUT pins S1-Port.

- ± 6 KV contact discharge, ± 8 KV air gap discharge based on IEC61000-4-2 level 3A, ± 8 KV Contact Discharge, and ± 15 KV air gap discharge based on IEC61000-4-2 level 4C

- Latch-up current..... > 200 mA
- Maximum output short-circuit current for all I/O configurations. (V<sub>out</sub> = 0 V)..... -100 mA

### Operating Conditions

- Ambient temperature under bias (T<sub>A</sub>)  
Industrial..... -40 °C to +85 °C
- V<sub>DD</sub>, A<sub>VDDQ</sub>, supply voltage..... 1.15 V to 1.25 V
- V<sub>BATT</sub> supply voltage..... 3.2 V to 6 V
- P<sub>VDDQ</sub>, S0<sub>VDDQ</sub>, S1<sub>VDDQ</sub>, L<sub>VDDQ</sub>, C<sub>VDDQ</sub>  
supply voltage..... 1.7 V to 3.6 V
- I<sup>2</sup>C<sub>VDDQ</sub> supply voltage..... 1.15 V to 3.6 V

### DC Specifications

Parameter	Description	Min	Max	Units	Notes
V <sub>DD</sub>	Core voltage supply	1.15	1.25	V	1.2-V typical
A <sub>VDD</sub>	Analog voltage supply	1.15	1.25	V	1.2-V typical
P <sub>VDDQ</sub>	P-Port I/O voltage supply	1.7	3.6	V	1.8-, 2.5-, and 3.3-V typical
S0 <sub>VDDQ</sub>	S0 Port I/O voltage supply	1.7	3.6	V	1.8-, 2.5-, and 3.3-V typical
S1 <sub>VDDQ</sub>	S1 Port I/O voltage supply	1.7	3.6	V	1.8-, 2.5-, and 3.3-V typical
L <sub>VDDQ</sub>	LPP I/O voltage supply	1.7	3.6	V	1.8-, 2.5-, and 3.3-V typical
V <sub>BATT</sub>	USB voltage supply	3.2	6	V	3.7-V typical
V <sub>BUS</sub>	USB voltage supply	4.0	6	V	5-V typical
C <sub>VDDQ</sub>	Clock voltage supply	1.7	3.6	V	1.8-, 3.3-V typical
I <sup>2</sup> C <sub>VDDQ</sub>	I <sup>2</sup> C voltage supply	1.15	3.6	V	1.2-, 1.8-, 2.5-, and 3.3-V typical
V <sub>IH1</sub>	Input HIGH voltage 1	0.625 × VCC	VCC+0.3	V	For 2.0 V ≤ V <sub>CC</sub> ≤ 3.6 V (except USB port). VCC is the corresponding IO voltage supply.
V <sub>IH2</sub>	Input HIGH voltage 2	VCC - 0.4	VCC+0.3	V	For 1.7 V ≤ V <sub>CC</sub> ≤ 2.0 V (except USB port). VCC is the corresponding IO voltage supply.
V <sub>IL</sub>	Input LOW voltage	-0.3	0.25 × VCC	V	VCC is the corresponding I/O voltage supply.
V <sub>OH</sub>	Output HIGH voltage	0.9 × VCC	-	V	I <sub>OH</sub> (max) = -100 μA tested at quarter drive strength. VCC is the corresponding I/O voltage supply.
V <sub>OL</sub>	Output LOW voltage	-	0.1 × VCC	V	I <sub>OL</sub> (min) = +100 μA tested at quarter drive strength. VCC is the corresponding I/O voltage supply.

**DC Specifications** (continued)

Parameter	Description	Min	Max	Units	Notes
$I_{IX}$	Input leakage current	-1	1	$\mu\text{A}$	All I/O signals held at $V_{DDQ}$ For I/Os with a pull-up/pull-down resistor connected, the leakage current increases by $V_{DDQ}/R_{pu}$ or $V_{DDQ}/R_{pd}$
$I_{OZ}$	Output high-Z leakage current	-1	1	$\mu\text{A}$	All I/O signals held at $V_{DDQ}$
$I_{CC}$ Core	Core and analog voltage operating current	-	200	mA	Total current through $A_{VDD}$ , $V_{DD}$
$I_{CC}$ USB	USB voltage supply voltage operating current	-	60	mA	
$ISB_{suspend}$	Total suspend current during suspend mode	-	-	mA	Core current: 250 $\mu\text{A}$ I/O current: 20 $\mu\text{A}$ USB current: 1.2 mA For typical PVT (typical silicon, all power supplies at their respective nominal levels at 25 °C.)
$ISB_{standby}$	Total standby current during standby mode	-	-	$\mu\text{A}$	Core current: 60 $\mu\text{A}$ I/O current: 20 $\mu\text{A}$ USB current: 40 $\mu\text{A}$ For typical PVT (typical silicon, all power supplies at their respective nominal levels at 25 °C.)
$ISB_{core}$	Total standby current during core power-down mode	-	-	$\mu\text{A}$	Core current: 0 $\mu\text{A}$ I/O current: 20 $\mu\text{A}$ USB current: 40 $\mu\text{A}$ For typical PVT (typical silicon, all power supplies at their respective nominal levels at 25 °C.)
$V_{RAMP}$	Voltage ramp rate on core and I/O supplies	0.2	50	V/ms	Voltage ramp must be monotonic
$V_N$	Noise level permitted on $V_{DD}$ and I/O supplies	-	100	mV	Max p-p noise level permitted on all supplies except $A_{VDD}$
$V_{N\_AVDD}$	Noise level permitted on $A_{VDD}$ supply	-	20	mV	Max p-p noise level permitted on $A_{VDD}$

## AC Timing Parameters

### Storage Port Timing

The S0-Port and S1-Port support the MMC specification Version 4.4 and SD Specification Version 3.0. [Table 10](#) lists the timing parameters for the Bay device's S-Port.

**Table 10. S-Port Timing Parameters<sup>[5]</sup>**

Parameter	Description	Min	Max	Units
<b>MMC-20</b>				
tSDIS CMD	Host input setup time for CMD	4.8	–	ns
tSDIS DAT	Host input setup time for DAT	4.8	–	ns
tSDIH CMD	Host input hold time for CMD	4.4	–	ns
tSDIH DAT	Host input hold time for DAT	4.4	–	ns
tSDOS CMD	Host output setup time for CMD	5	–	ns
tSDOS DAT	Host output setup time for DAT	5	–	ns
tSDOH CMD	Host output hold time for CMD	5	–	ns
tSDOH DAT	Host output hold time for DAT	5	–	ns
tSCLKR	Clock rise time	–	2	ns
tSCLKF	Clock fall time	–	2	ns
tSDCK	Clock cycle time	50	–	ns
SDFREQ	Clock frequency	–	20	MHz
tSDCLKOD	Clock duty cycle	40	60	%
<b>MMC-26</b>				
tSDIS CMD	Host input setup time for CMD	10	–	ns
tSDIS DAT	Host input setup time for DAT	10	–	ns
tSDIH CMD	Host input hold time for CMD	9	–	ns
tSDIH DAT	Host input hold time for DAT	9	–	ns
tSDOS CMD	Host output setup time for CMD	3	–	ns
tSDOS DAT	Host output setup time for DAT	3	–	ns
tSDOH CMD	Host output hold time for CMD	3	–	ns
tSDOH DAT	Host output hold time for DAT	3	–	ns
tSCLKR	Clock rise time	–	2	ns
tSCLKF	Clock fall time	–	2	ns
tSDCK	Clock cycle time	38.5	–	ns
SDFREQ	Clock frequency	–	26	MHz
tSDCLKOD	Clock duty cycle	40	60	%
<b>MC-HS</b>				
tSDIS CMD	Host input setup time for CMD	4	–	ns
tSDIS DAT	Host input setup time for DAT	4	–	ns
tSDIH CMD	Host input hold time for CMD	3	–	ns
tSDIH DAT	Host input hold time for DAT	3	–	ns
tSDOS CMD	Host output setup time for CMD	3	–	ns
tSDOS DAT	Host output setup time for DAT	3	–	ns
tSDOH CMD	Host output hold time for CMD	3	–	ns
tSDOH DAT	Host output hold time for DAT	3	–	ns
tSCLKR	Clock rise time	–	2	ns

Table 10. S-Port Timing Parameters<sup>[5]</sup> (continued)

Parameter	Description	Min	Max	Units
tSCLKF	Clock fall time	–	2	ns
tSDCK	Clock cycle time	19.2	–	ns
SDFREQ	Clock frequency	–	52	MHz
tSDCLKOD	Clock duty cycle	40	60	%
<b>MMC-DDR52</b>				
tSDIS CMD	Host input setup time for CMD	4	–	ns
tSDIS DAT	Host input setup time for DAT	0.56	–	ns
tSDIH CMD	Host input hold time for CMD	3	–	ns
tSDIH DAT	Host input hold time for DAT	2.58	–	ns
tSDOS CMD	Host output setup time for CMD	3	–	ns
tSDOS DAT	Host output setup time for DAT	2.5	–	ns
tSDOH CMD	Host output hold time for CMD	3	–	ns
tSDOH DAT	Host output hold time for DAT	2.5	–	ns
tSCLKR	Clock rise time	–	2	ns
tSCLKF	Clock fall time	–	2	ns
tSDCK	Clock cycle time	19.2	–	ns
SDFREQ	Clock frequency	–	52	MHz
tSDCLKOD	Clock duty cycle	45	55	%
<b>SD-Default Speed (SDR12)</b>				
tSDIS CMD	Host input setup time for CMD	24	–	ns
tSDIS DAT	Host input setup time for DAT	24	–	ns
tSDIH CMD	Host input hold time for CMD	2.5	–	ns
tSDIH DAT	Host input hold time for DAT	2.5	–	ns
tSDOS CMD	Host output setup time for CMD	5	–	ns
tSDOS DAT	Host output setup time for DAT	5	–	ns
tSDOH CMD	Host output hold time for CMD	5	–	ns
tSDOH DAT	Host output hold time for DAT	5	–	ns
tSCLKR	Clock rise time	–	2	ns
tSCLKF	Clock fall time	–	2	ns
tSDCK	Clock cycle time	40	–	ns
SDFREQ	Clock frequency	–	25	MHz
tSDCLKOD	Clock duty cycle	40	60	%
<b>SD-High-Speed(SDR25)</b>				
tSDIS CMD	Host input setup time for CMD	4	–	ns
tSDIS DAT	Host input setup time for DAT	4	–	ns
tSDIH CMD	Host input hold time for CMD	2.5	–	ns
tSDIH DAT	Host input hold time for DAT	2.5	–	ns
tSDOS CMD	Host output setup time for CMD	6	–	ns
tSDOS DAT	Host output setup time for DAT	6	–	ns
tSDOH CMD	Host output hold time for CMD	2	–	ns
tSDOH DAT	Host output hold time for DAT	2	–	ns
tSCLKR	Clock rise time	–	2	ns

Table 10. S-Port Timing Parameters<sup>[5]</sup> (continued)

Parameter	Description	Min	Max	Units
tSCLKF	Clock fall time	–	2	ns
tSDCK	Clock cycle time	20	–	ns
SDFREQ	Clock frequency	–	50	MHz
tSDCLKOD	Clock duty cycle	40	60	%
<b>SD-SDR50</b>				
tSDIS CMD	Host input setup time for CMD	1.5	–	ns
tSDIS DAT	Host input setup time for DAT	1.5	–	ns
tSDIH CMD	Host input hold time for CMD	2.5	–	ns
tSDIH DAT	Host input hold time for DAT	2.5	–	ns
tSDOS CMD	Host output setup time for CMD	3	–	ns
tSDOS DAT	Host output setup time for DAT	3	–	ns
tSDOH CMD	Host output hold time for CMD	0.8	–	ns
tSDOH DAT	Host output hold time for DAT	0.8	–	ns
tSCLKR	Clock rise time	–	2	ns
tSCLKF	Clock fall time	–	2	ns
tSDCK	Clock cycle time	10	–	ns
SDFREQ	Clock frequency	–	100	MHz
tSDCLKOD	Clock duty cycle	40	60	%
<b>SD-DDR50</b>				
tSDIS CMD	Host input setup time for CMD	4	–	ns
tSDIS DAT	Host input setup time for DAT	0.92	–	ns
tSDIH CMD	Host input hold time for CMD	2.5	–	ns
tSDIH DAT	Host input hold time for DAT	2.5	–	ns
tSDOS CMD	Host output setup time for CMD	6	–	ns
tSDOS DAT	Host output setup time for DAT	3	–	ns
tSDOH CMD	Host output hold time for CMD	0.8	–	ns
tSDOH DAT	Host output hold time for DAT	0.8	–	ns
tSCLKR	Clock rise time	–	2	ns
tSCLKF	Clock fall time	–	2	ns
tSDCK	Clock cycle time	20	–	ns
SDFREQ	Clock frequency	–	50	MHz
tSDCLKOD	Clock duty cycle	45	55	%

**Note**

5. All parameters guaranteed by design and validated through characterization.

Host Processor Interface (P-Port) Timing

Asynchronous SRAM Timing

Figure 11. Non-multiplexed Asynchronous SRAM Read Timing

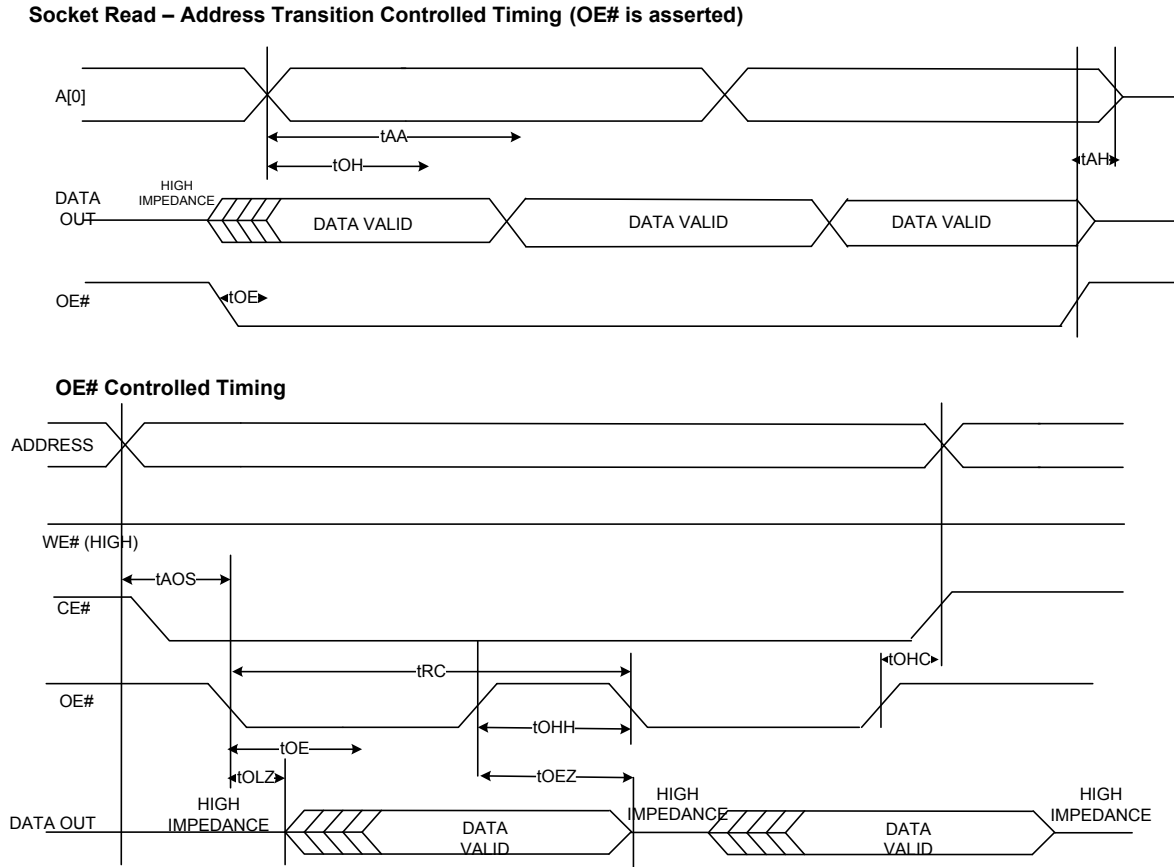
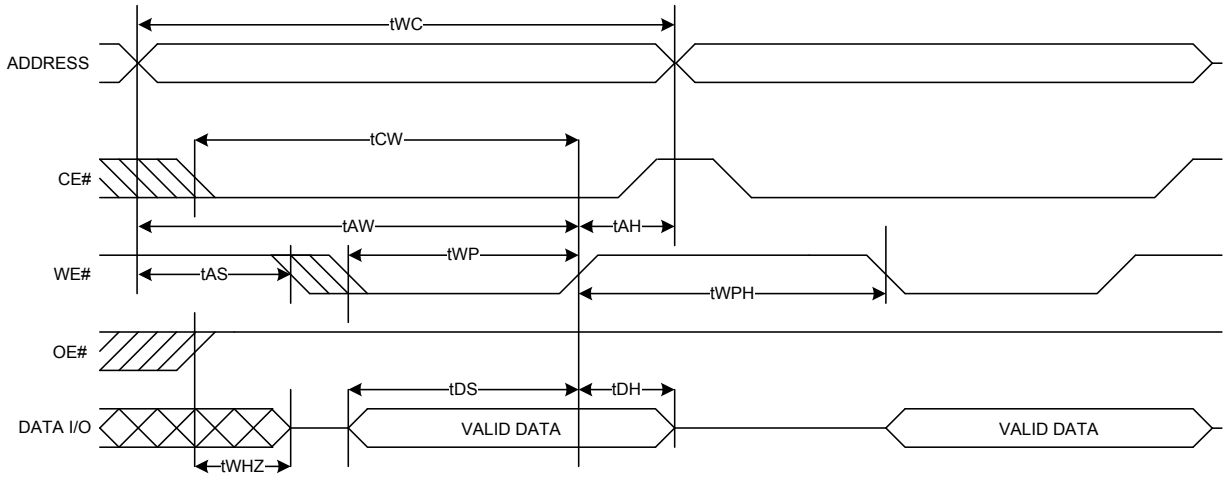

Figure 12. Non-multiplexed Asynchronous SRAM Write Timing (WE# and CE# controlled)

Write Cycle 1 WE# Controlled, OE# High During Write



Write Cycle 2 CE# Controlled, OE# High During Write

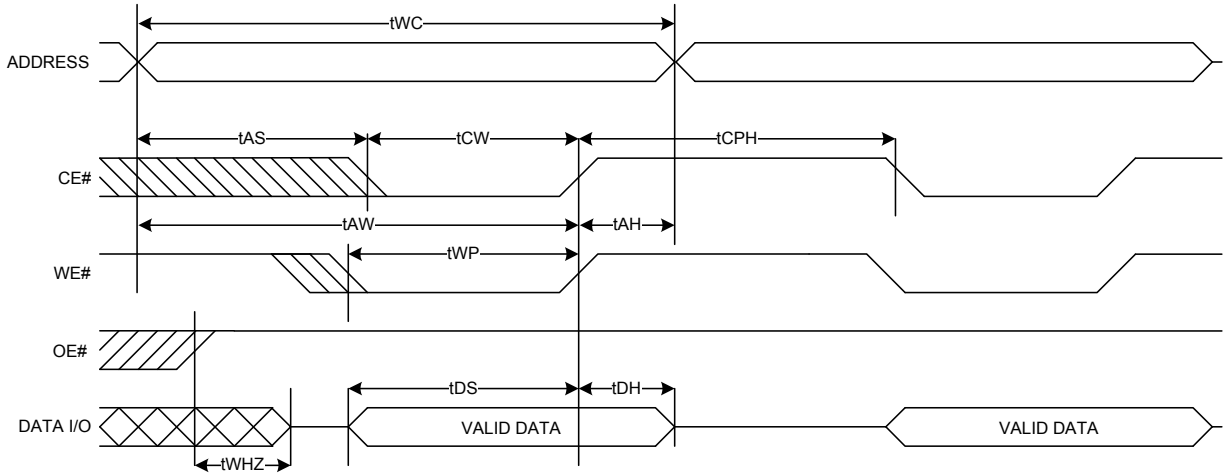
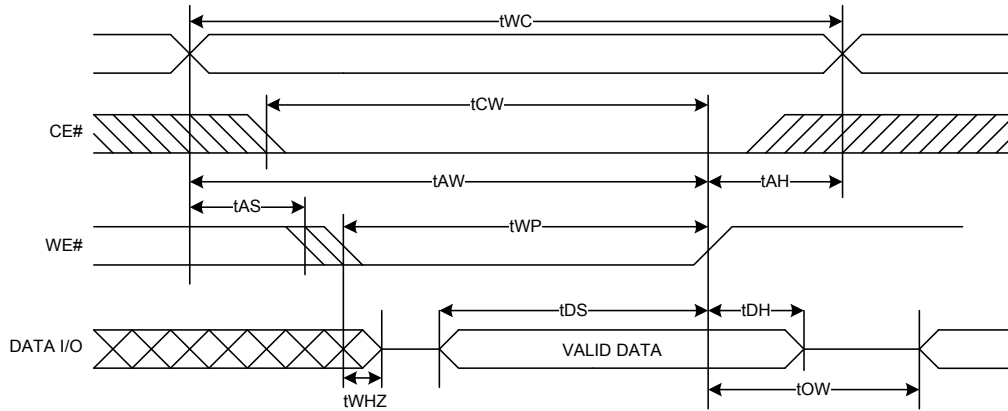



Figure 13. Non-multiplexed Asynchronous SRAM Write Timing (WE# controlled, OE# LOW)

Write Cycle 3 WE# Controlled. OE# Low



Note: tWP must be adjusted such that  $tWP > tWHZ + tDS$

Table 11. Asynchronous SRAM Timing Parameters<sup>[6]</sup>

Parameter	Description	Min	Max	Units	Notes
	SRAM interface bandwidth	–	61.5	MBps	
tRC	Read cycle time	32.5	–	ns	
tAA	Address to data valid	–	30	ns	
tAOS	Address to OE# LOW setup time	7	–	ns	
tOH	Data output hold from address change	3	–	ns	
tOHH	OE# HIGH hold time	7.5	–	ns	
tOHC	OE# HIGH to CE# HIGH	2	–	ns	
tOE	OE# LOW to data valid	–	25	ns	
tOLZ	OE# LOW to LOW-Z	0	–	ns	
tWC	Write cycle time	30	–	ns	
tCW	CE# LOW to write end	30	–	ns	
tAW	Address valid to write end	30	–	ns	
tAS	Address setup to write start	7	–	ns	
tAH	Address hold time from CE# or WE#	2	–	ns	
tWP	WE# pulse width	20	–	ns	
tWPH	WE# HIGH time	10	–	ns	
tCPH	CE# HIGH time	10	–	ns	
tDS	Data setup to write end	7	–	ns	
tDH	Data hold to write end	2	–	ns	
tWHZ	Write to DQ high-Z output	–	22.5	ns	
tOEZ	OE# HIGH to DQ high-Z output	–	22.5	ns	
tOW	End of write to low-Z output	0	–	ns	

Note

6. All parameters guaranteed by design and validated through characterization.

ADMux Timing for Asynchronous Access

Figure 14. ADMux Asynchronous Random Read

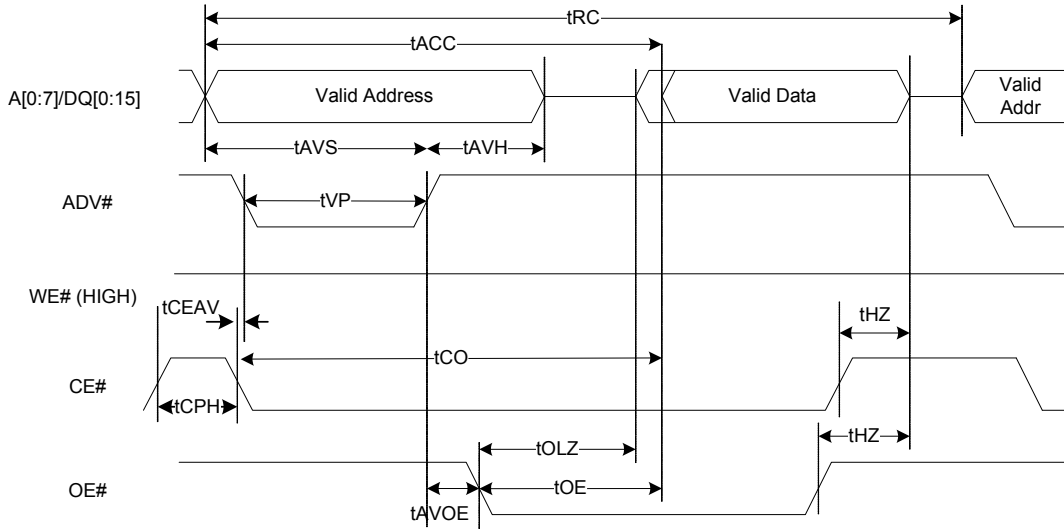

Note:

- Multiple read cycles can be executed while keeping CE# low.
- Read operation ends with either de-assertion of either OE# or CE#, whichever comes earlier.

Figure 15. ADMux Asynchronous Random Write

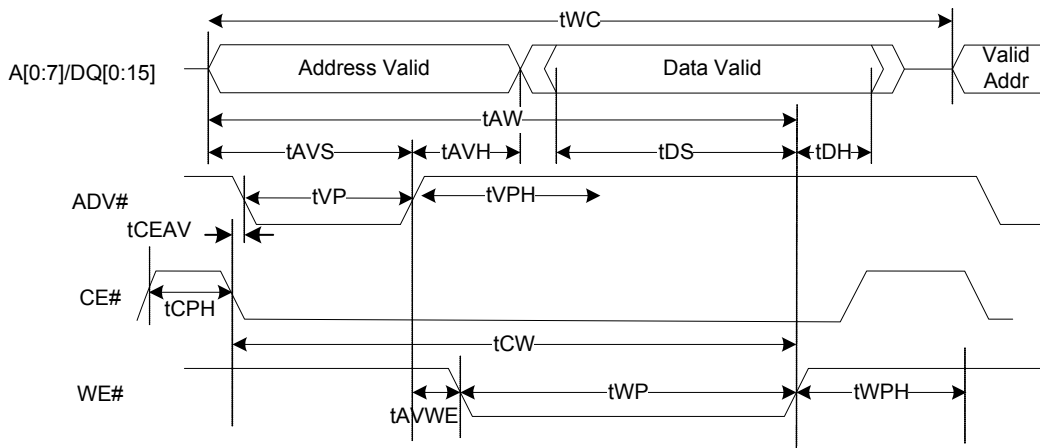

Note:

- Multiple write cycles can be executed while keeping CE# low.
- Write operation ends with de-assertion of either WE# or CE#, whichever comes earlier.

Table 12. Asynchronous ADMux Timing Parameters<sup>[7]</sup>

Parameter	Description	Min	Max	Units	Notes
<b>ADMux Asynchronous READ Access Timing Parameters</b>					
tRC	Read cycle time (address valid to address valid)	54.5	–	ns	This parameter is dependent on when the P-port processors deasserts OE#
tACC	Address valid to data valid	–	32	ns	
tCO	CE# assert to data valid	–	34.5	ns	
tAVOE	ADV# deassert to OE# assert	2	–	ns	
tOLZ	OE# assert to data LOW-Z	0	–	ns	
tOE	OE# assert to data valid	–	25	ns	
tHZ	Read cycle end to data HIGH-Z	–	22.5	ns	
<b>ADMux Asynchronous WRITE Access Timing Parameters</b>					
tWC	Write cycle time (address valid to address valid)	–	52.5	ns	
tAW	Address valid to write end	30	–	ns	
tCW	CE# assert to write end	30	–	ns	
tAVWE	ADV# deassert to WE# assert	2	–	ns	
tWP	WE# LOW pulse width	20	–	ns	
tWPH	WE# HIGH pulse width	10	–	ns	
tDS	Data valid setup to WE# deassert	18	–	ns	
tDH	Data valid hold from WE# deassert	2	–	ns	
<b>ADMux Asynchronous Common READ/WRITE Access Timing Parameters</b>					
tAVS	Address valid setup to ADV# deassert	5	–	ns	
tAVH	Address valid hold from ADV# deassert	2	–	ns	
tVP	ADV# LOW pulse width	7.5	–	ns	
tCPH	CE# HIGH pulse width	10	–	ns	
tVPH	ADV# HIGH pulse width	15	–	ns	
tCEAV	CE# assert to ADV# assert	0	–	ns	

**Note**

7. All parameters guaranteed by design and validated through characterization.

Synchronous ADMux Timing

Figure 16. Synchronous ADMux Interface – Read Cycle Timing

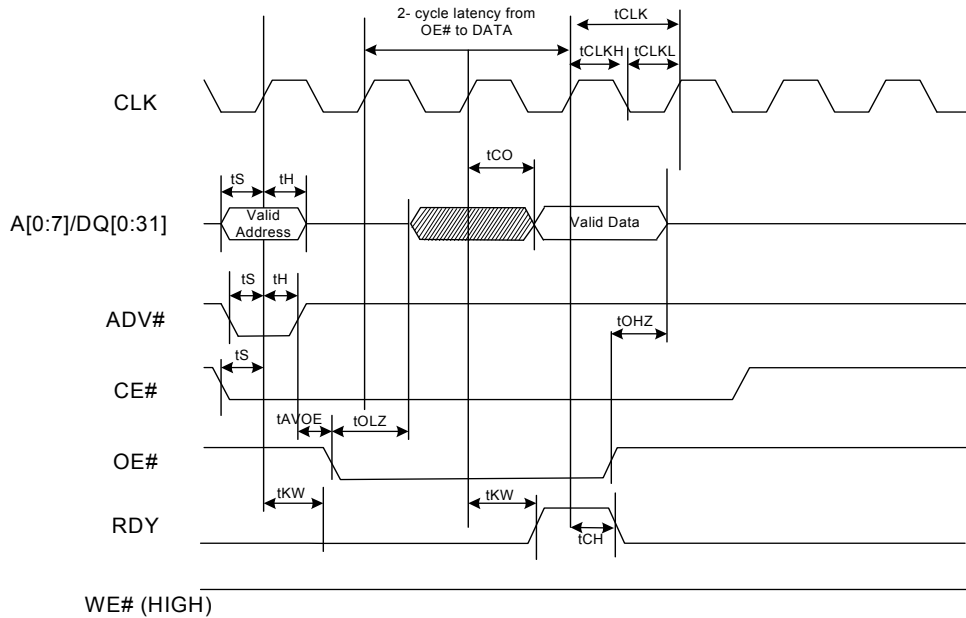

Note:

- 1) External P-Port processor and West Bridge Benicia operate on the same clock edge
- 2) External processor sees RDY assert 2 cycles after OE # asserts and sees RDY deassert a cycle after the data appears on the output
- 3) Valid output data appears 2 cycle after OE # asserted. The data is held until OE # deasserts
- 4) Two cycle latency is shown for 0-100 MHz operation. Latency can be reduced by 1 cycle for operations at less than 50 MHz (this 1 cycle latency is not supported by bootloader)

Figure 17. Synchronous ADMux Interface – Write Cycle Timing

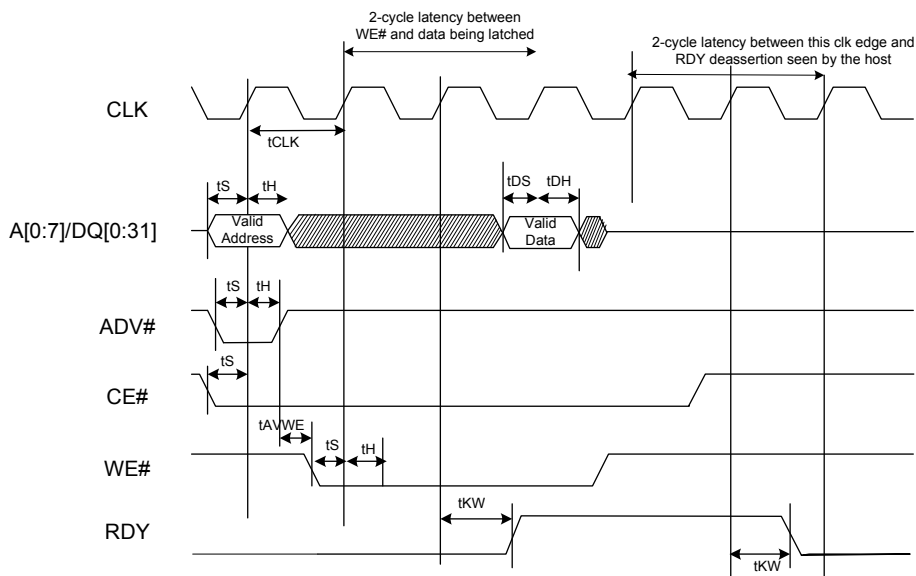

Note:

- 1) External P-Port processor and West Bridge Benicia operate on the same clock edge
- 2) External processor sees RDY assert 2 cycles after WE # asserts and deassert 3 cycles after the edge sampling the data.
- 3) Two cycle latency is shown for 0-100 MHz operation. Latency can be reduced by 1 cycle at operations less than 50 MHz (this 1 cycle latency is not supported by bootloader)

Figure 18. Sync ADMux Interface - Burst Read Timing

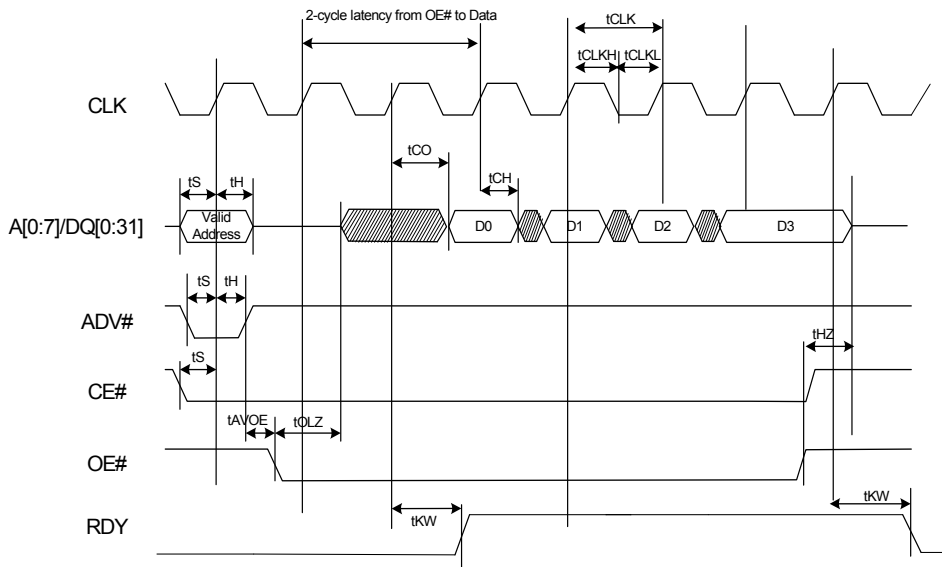

Note:

- 1) External P-Port processor and West Bridge Benicia work operate on the same clock edge
- 2) External processor sees RDY assert 2 cycles after OE # asserts and deasserts a cycle after the last burst data appears on the output
- 3) Valid output data appears 2 cycle after OE # asserts. The last burst data is held until OE # deasserts
- 4) Burst size of 4 is shown. Transfer size for the operation must be a multiple of burst size. Burst size is usually power of 2. RDY will not deassert in the middle of the burst.
- 5) External processor cannot deassert OE in the middle of a burst. If it does so, any bytes remaining in the burst packet could get lost.
- 6) Two cycle latency is shown for 0-100 MHz operation. Latency can be reduced by 1 cycle at operations less than 50 MHz (this 1 cycle latency is not supported by bootloader)

Figure 19. Sync ADMux Interface - Burst Write Timing

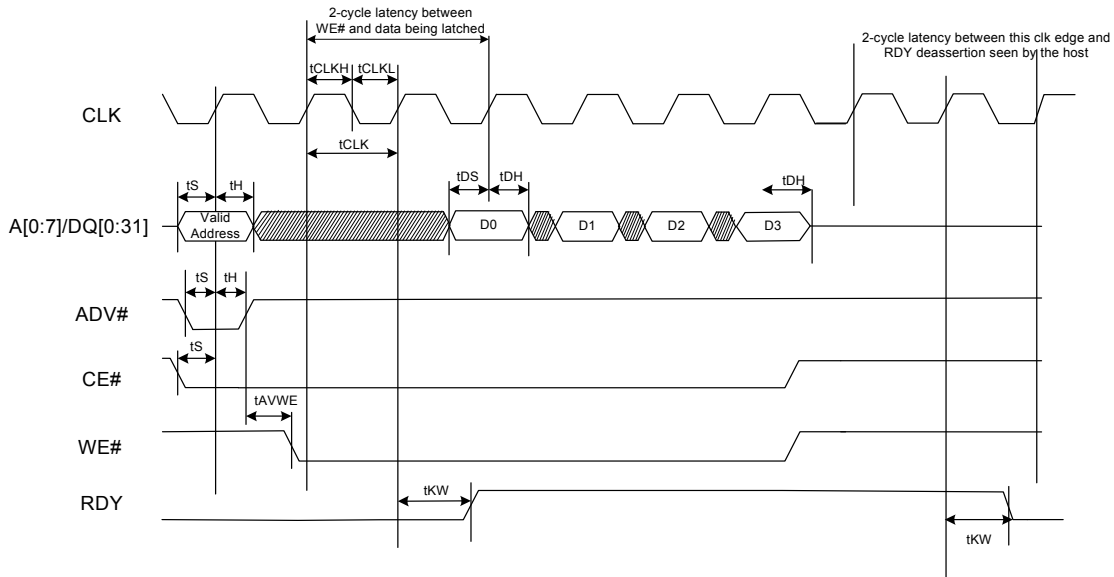

Note:

- 1) External P-Port processor and West Bridge Benicia operate on the same clock edge
- 2) External processor sees RDY assert 2 cycles after WE # asserts and deasserts 3 cycles after the edge sampling the last burst data.
- 3) Transfer size for the operation must be a multiple of burst size. Burst size is usually power of 2. RDY will not deassert in the middle of the burst. Burst size of 4 is shown
- 4) External processor cannot deassert WE in the middle of a burst. If it does so, any bytes remaining in the burst packet could get lost.
- 5) Two cycle latency is shown for 0-100 MHz operation. Latency can be reduced by 1 cycle at operations less than 50 MHz (this 1 cycle latency is not supported by bootloader)

Table 13. Synchronous ADMux Timing Parameters<sup>[8]</sup>

Parameter	Description	Min	Max	Unit
FREQ	Interface clock frequency	–	100	MHz
tCLK	Clock period	10	–	ns
tCLKH	Clock HIGH time	4	–	ns
tCLKL	Clock LOW time	4	–	ns
tS	CE#/WE#/DQ setup time	2	–	ns
tH	CE#/WE#/DQ hold time	0.5	–	ns
tCH	Clock to data output hold time	0	–	ns
tDS	Data input setup time	2	–	ns
tDH	Clock to data input hold	0.5	–	ns
tAVDOE	ADV# HIGH to OE# LOW	0	–	ns
tAVDWE	ADV# HIGH to WE# LOW	0	–	ns
tHZ	CE# HIGH to Data HIGH-Z	–	8	ns
tOHZ	OE# HIGH to Data HIGH-Z	–	8	ns
tOLZ	OE# LOW to Data LOW-Z	0	–	ns
tKW	Clock to RDY valid	–	8	ns

Low Performance Peripherals Timing

I<sup>2</sup>C Timing

Figure 20. I<sup>2</sup>C Timing Definition

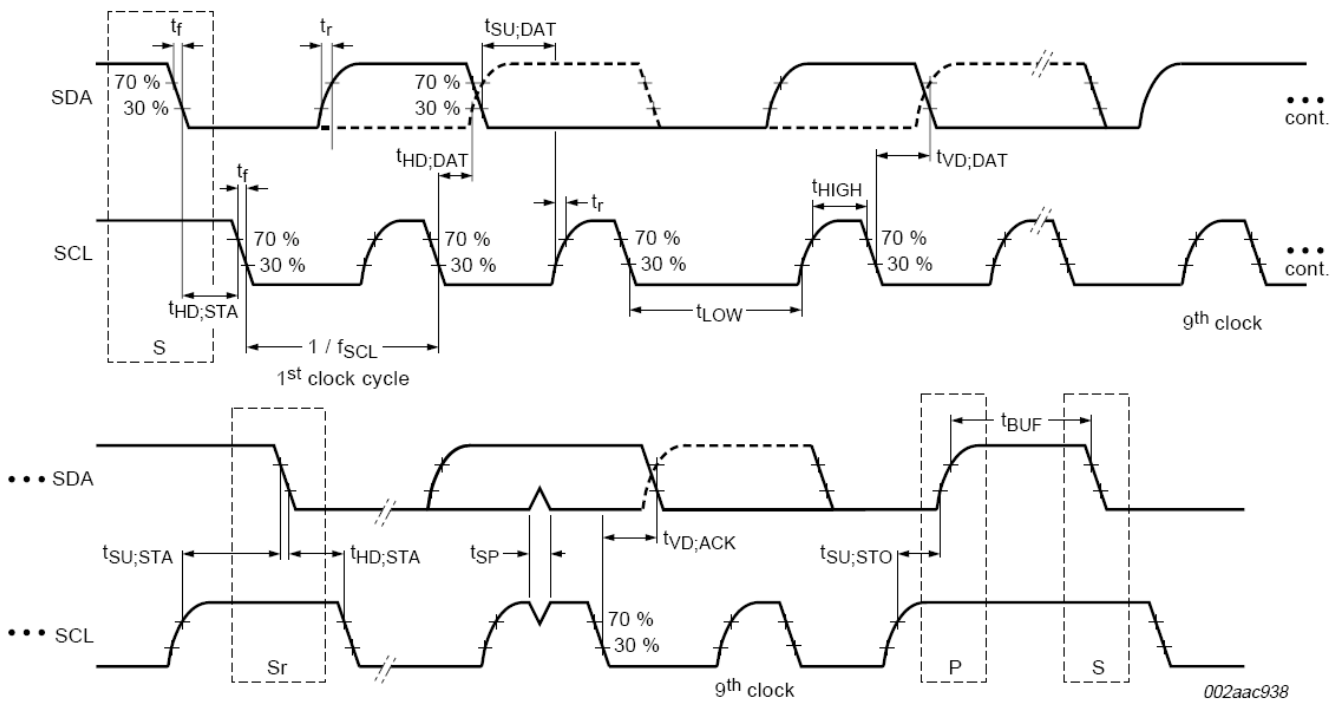

Note

8. All parameters guaranteed by design and validated through characterization.

**Table 14. I<sup>2</sup>C Timing Parameters** <sup>[9]</sup>

Parameter	Description	Min	Max	Units	Notes
<b>I<sup>2</sup>C Standard Mode Parameters</b>					
fSCL	SCL clock frequency	0	100	kHz	
tHD:STA	Hold time START condition	4	–	μs	
tLOW	LOW period of the SCL	4.7	–	μs	
tHIGH	HIGH period of the SCL	4	–	μs	
tSU:STA	Setup time for a repeated START condition	4.7	–	μs	
tHD:DAT	Data hold time	0	–	μs	
tSU:DAT	Data setup time	250	–	ns	
tr	Rise time of both SDA and SCL signals	–	1000	ns	
tf	Fall time of both SDA and SCL signals	–	300	ns	
tSU:STO	Setup time for STOP condition	4	–	μs	
tBUF	Bus free time between a STOP and START condition	4.7	–	μs	
tVD:DAT	Data valid time	–	3.45	μs	
tVD:ACK	Data valid ACK	–	3.45	μs	
tSP	Pulse width of spikes that must be suppressed by input filter	–	–		
<b>I<sup>2</sup>C Fast Mode Parameters</b>					
fSCL	SCL clock frequency	0	400	kHz	
tHD:STA	Hold time START condition	0.6	–	μs	
tLOW	LOW period of the SCL	1.3	–	μs	
tHIGH	HIGH period of the SCL	0.6	–	μs	
tSU:STA	Setup time for a repeated START condition	0.6	–	μs	
tHD:DAT	Data hold time	0	–	μs	
tSU:DAT	Data setup time	100	–	ns	
tr	Rise time of both SDA and SCL signals	–	300	ns	
tf	Fall time of both SDA and SCL signals	–	300	ns	
tSU:STO	Setup time for STOP condition	0.6	–	μs	
tBUF	Bus free time between a STOP and START condition	1.3	–	μs	
tVD:DAT	Data valid time	–	0.9	μs	
tVD:ACK	Data valid ACK	–	0.9	μs	
tSP	Pulse width of spikes that must be suppressed by input filter	0	50	ns	
<b>I<sup>2</sup>C Fast Mode Plus Parameters (Not supported at I2CVDDQ = 1.2 V)</b>					
fSCL	SCL clock frequency	0	1000	kHz	
tHD:STA	Hold time START condition	0.26	–	μs	
tLOW	LOW period of the SCL	0.5	–	μs	
tHIGH	HIGH period of the SCL	0.26	–	μs	
tSU:STA	Setup time for a repeated START condition	0.26	–	μs	
tHD:DAT	Data hold time	0	–	μs	
tSU:DAT	Data setup time	50	–	ns	
tr	Rise time of both SDA and SCL signals	–	120	ns	
tf	Fall time of both SDA and SCL signals	–	120	ns	
tSU:STO	Setup time for STOP condition	0.26	–	μs	
tBUF	Bus free time between a STOP and START condition	0.5	–	μs	
tVD:DAT	Data valid time	–	0.45	μs	
tVD:ACK	Data valid ACK	–	0.55	μs	
tSP	Pulse width of spikes that must be suppressed by input filter	0	50	ns	

**Note**

9. All parameters guaranteed by design and validated through characterization.

I<sup>2</sup>S Timing Diagram

Figure 21. I<sup>2</sup>S Transmit Cycle

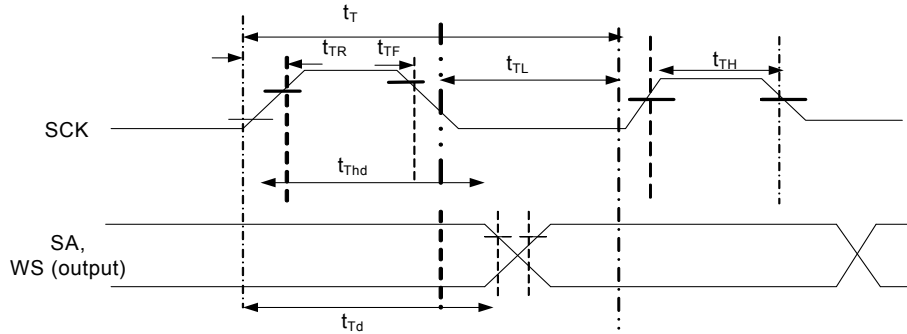

Table 15. I<sup>2</sup>S Timing Parameters<sup>[10]</sup>

Parameter	Description	Min	Max	Units
$t_T$	I <sup>2</sup> S transmitter clock cycle	$T_{tr}$	–	ns
$t_{TL}$	I <sup>2</sup> S transmitter cycle LOW period	$0.35 T_{tr}$	–	ns
$t_{TH}$	I <sup>2</sup> S transmitter cycle HIGH period	$0.35 T_{tr}$	–	ns
$t_{TR}$	I <sup>2</sup> S transmitter rise time	–	$0.15 T_{tr}$	ns
$t_{TF}$	I <sup>2</sup> S transmitter fall time	–	$0.15 T_{tr}$	ns
$t_{Thd}$	I <sup>2</sup> S transmitter data hold time	0	–	ns
$t_{Td}$	I <sup>2</sup> S transmitter delay time	–	$0.8 t_T$	ns

**Note**  $t_T$  is selectable through clock gears. Max  $T_{tr}$  is designed for 96-kHz codec at 32 bits to be 326 ns (3.072 MHz).

**Note**

10. All parameters guaranteed by design and validated through characterization.



SPI Timing Specification

Figure 22. SPI Timing

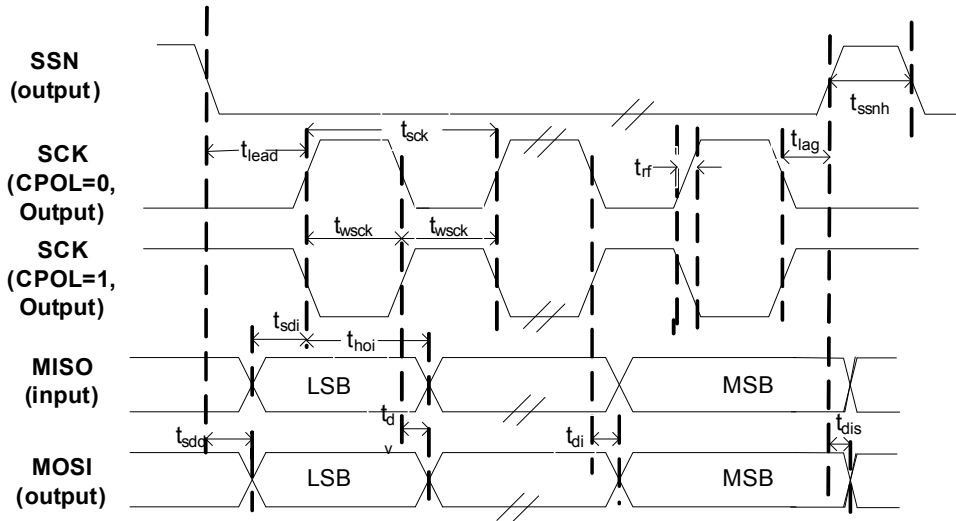

SPI Master Timing for CPHA = 0

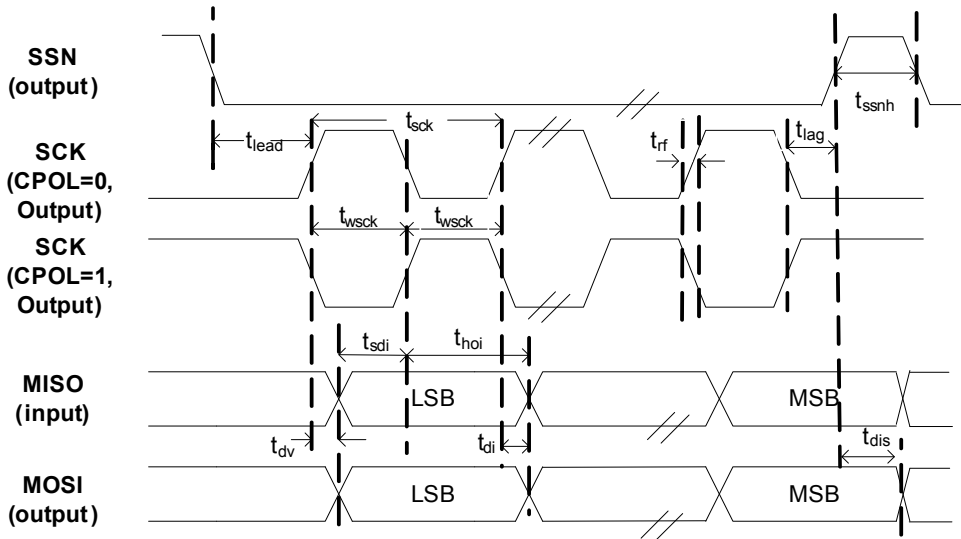

SPI Master Timing for CPHA = 1

**Table 16. SPI Timing Parameters<sup>[11]</sup>**

Parameter	Description	Min	Max	Units
fop	Operating frequency	0	33	MHz
tsck	Cycle time	30	–	ns
twscck	Clock HIGH/LOW time	13.5	–	ns
tlead	SSN-SCK lead time	$1/2 \text{ tsck}^{[12]} - 5$	$1.5 \text{ tsck}^{[12]} + 5$	ns
tlag	Enable lag time	0.5	$1.5 \text{ tsck}^{[12]} + 5$	ns
trf	Rise/fall time	–	8	ns
tsdd	Output SSN to valid data delay time	–	5	ns
tdv	Output data valid time	–	5	ns
tdi	Output data invalid	0	–	ns
tssnh	Minimum SSN HIGH time	10	–	ns
tsdi	Data setup time input	8	–	ns
thoi	Data hold time input	0	–	ns
tdis	Disable data output on SSN HIGH	0	–	ns

## Reset Sequence

The hard reset sequence requirements for West Bridge Bay are specified in the following table.

**Table 17. Reset and Standby Timing Parameters**

Parameter	Description	Conditions	Min	Max	Units
tRPW	Minimum RESET# pulse width	Clock input	1	–	ms
		Crystal input	1	–	ms
tRH	Minimum HIGH on RESET#		5	–	ms
tRR	Reset recovery time (after which boot loader begins firmware download)	Clock input	1	–	ms
		Crystal input	5		ms
tSBY	Time to enter standby/suspend (from the time MAIN_CLOCK_EN/ MAIN_POWER_EN bit is set)		–	1	ms
tWU	Time to wakeup from standby	Clock input	1	–	ms
		Crystal input	5	–	ms
tWH	Minimum time before standby/suspend source is reasserted		5	–	ms

### Notes

- 11. All parameters guaranteed by design and validated through characterization.
- 12. Depends on LAG and LEAD setting in SPI\_CONFIG register.

Figure 23. Reset Sequence

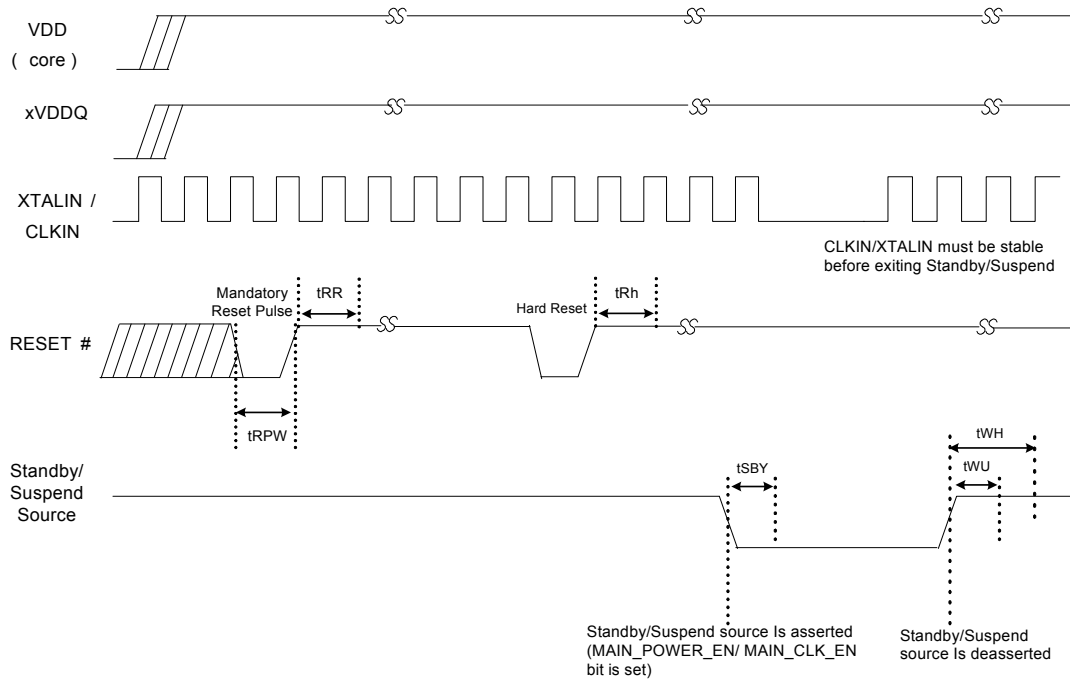

Package Diagram

Figure 24. 131-ball Benicia WLCSP (5.099 × 4.695 × 0.60 mm) Package Outline, 001-62221

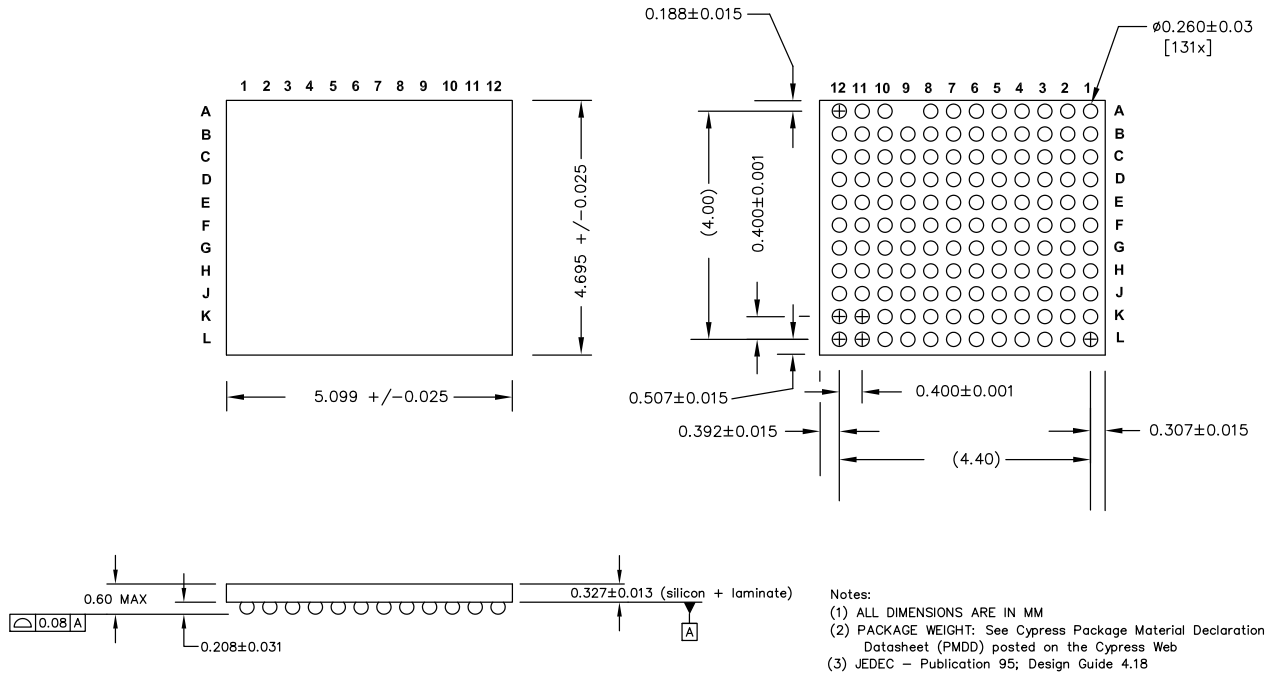

001-62221 \*C

Figure 25. 121-Ball FBGA 10 × 10 × 1.2 Diagram

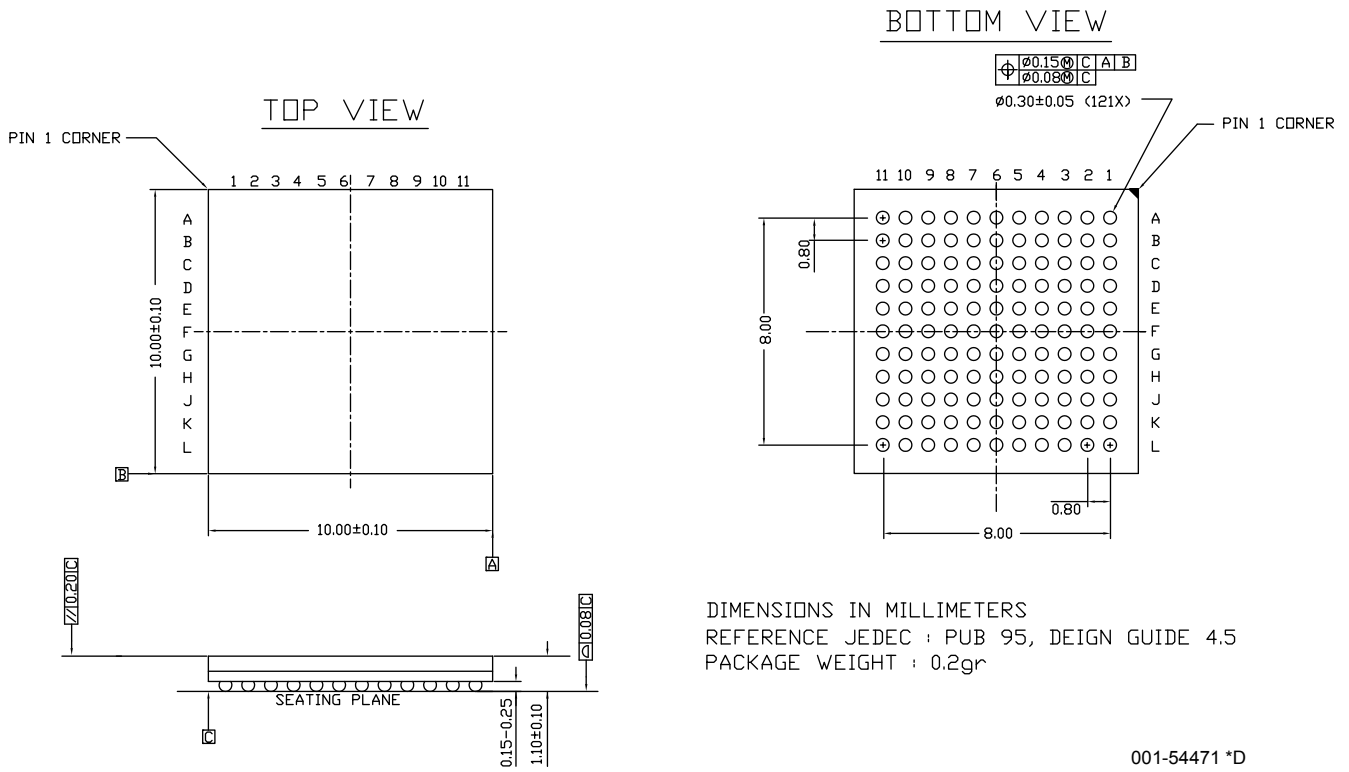

001-54471 \*D

**Note** Underfill is required on the board design. Contact Cypress Applications for details.

## Ordering Information

**Table 18. Ordering Information**

Ordering Code	Package Type	USB2.0 Integrated Switch
CYWB0163BB-FBXIT	131-ball WLCSP	Yes
CYWB0164BB-BZXI	121-ball BGA	No

## Ordering Code Definitions

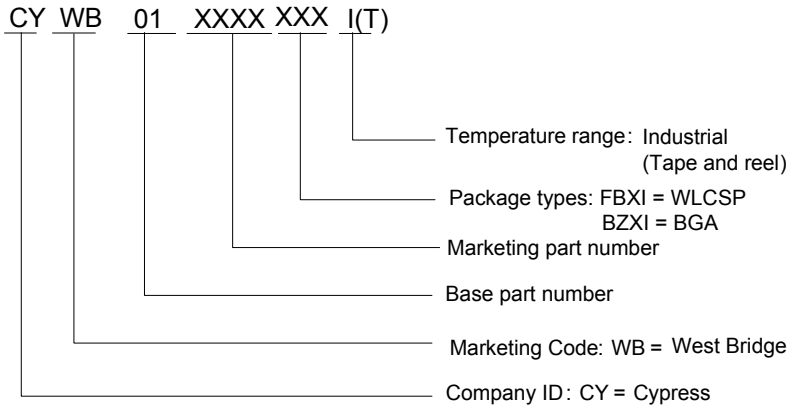

## Acronyms

Acronym	Description
ACA	Accessory Charger Adaptor
ADP	Attach Detection Protocol
DMA	Direct Memory Access
HID	Human Interface Device
HNP	Host Negotiation Protocol
MMC	Multimedia Card
MSC	Mass Storage Class
MTP	Media Transfer Protocol
OTG	On-The-Go
OVP	Overvoltage Protection
PLL	Phase Locked Loop
SCL	Serial Clock
SD	Secure Digital
SDA	Serial Data
SDIO	Secure Digital Input / Output
SLC	Single-Level Cell
SPI	Serial Peripheral Interface
SRP	Session Request Protocol
USB	Universal Serial Bus
WP	Write Protection
WLCSP	Wafer Level Chip Scale Package

## Document Conventions

### Units of Measure

Symbol	Unit of Measure
°C	degree Celsius
μA	microampere
μs	microsecond
KHz	kilohertz
mA	milliampere
Mbps	megabits per second
MBps	megabytes per second
MHz	megahertz
ms	millisecond
ns	nanosecond
Ω	ohm
pF	picofarad
V	volt

## Errata

This section describes the errata for West Bridge Bay and Benicia, CYWB0163BB-FBXI and CYWB0263BB-FBXI. Details include errata trigger conditions, scope of impact, available workaround, and silicon revision applicability.

Contact your local Cypress Sales Representative if you have questions.

### Part Numbers Affected

Part Number
CYWB0163BB-FBXI
CYWB0263BB-FBXI

### Bay and Benicia, USB and Mass Storage Peripheral Controller Qualification Status

Product Status: Sampling

### Bay and Benicia, USB and Mass Storage Peripheral Controller Errata Summary

This table defines the errata applicable to Bay and Benicia, USB and Mass Storage Peripheral Controller family devices.

**Note:** Errata items in the table below are hyperlinked. Click on any item entry to jump to its description.

Items	Part Number	Silicon Revision	Fix Status
<a href="#">1. USB Boot Is Not Stable</a>	CYWB0163BB-FBXI CYWB0263BB-FBXI	ES	1. Workaround provided. 2. Fix in Production Silicon.
<a href="#">2. P-Port Clock Stop</a>	CYWB0163BB-FBXI CYWB0263BB-FBXI	ES	1. Workaround provided.

#### 1. USB Boot Is Not Stable

##### ■ Problem Definition

Bay and Benicia may not enumerate with the USB host (for example: PC) and fail to boot from the USB port if after reset the PMODE pins are selected or configured to boot from USB.

##### ■ Parameters Affected

NA

##### ■ Trigger Condition(S)

This condition is triggered when PMODE pins is configured to boot from the USB port.

##### ■ Scope of Impact

Fail to boot from USB Port.

##### ■ Workaround

Select alternate boot option like I2C and P-Port etc. boot

##### ■ Fix Status

Fix in production silicon



## 2. P-Port Clock Stop

### ■ Problem Definition

Bay and Benicia require a free running clock on the P-Port in synchronous mode. In cases where free running clocks are not available P-Port DMA transfers will not work.

### ■ Parameters Affected

NA

### ■ Trigger Condition(S)

This condition is triggered when P-Port is configured to synchronous interface (for example synchronous ADMux interface).

### ■ Scope of Impact

In cases where free running clocks are not available P-Port DMA transfers will not work.

### ■ Workaround

Provide a free running clock or provide at least 150 clock edges before the clock stops.

### ■ Fix Status

No fix. Workaround is required.

Document History Page

Document Title: CYWB0163BB/CYWB0164BB, West Bridge® Bay™ USB and Mass Storage Controller				
Document Number: 001-45550				
Revision	ECN	Orig. of Change	Submission Date	Description of Change
**	2669072	VSO / PYRS	03/05/09	New data sheet
*A	2754304	VSO	08/21/09	Updated the part number (in title). The whole Features section has been updated. The whole Applications section has been updated. Updated the block diagram. The Functional Overview section has been updated. The Processor Interface section and sub-sections have been updated. Added Boot Options section. Added a section of Power. Added a section of Pin Description. Added Table 1. Pin List.
*B	2823531	OSG	12/08/09	Added data sheet to the USB 3.0 EROS spec 001-51884. No technical updates.
*C	3080927	OSG	11/08/2010	Changed status from Advance to Preliminary Changed part number from CYWB0101BB to CYWB0163BB Added the following sections: <a href="#">Power</a> , <a href="#">Configuration Options</a> , <a href="#">Digital I/Os</a> , <a href="#">EMI</a> , <a href="#">System-level ESD</a> , <a href="#">Absolute Maximum Ratings</a> , <a href="#">AC Timing Parameters</a> , <a href="#">Reset Sequence</a> Added <a href="#">DC Specifications</a> table Updated Pin List Updated block diagram
*D	3204393	OSG	03/24/2011	Changed Async SRAM tOE parameter Changed Async SRAM tRC parameter Changed Async ADMux tOE parameter Changed Async ADMux tRC parameter Changed Async ADMux tACC parameter Changed Async ADMux tCO parameter Changed Async SRAM max interface throughput Updated dimensions of WLCSP package Updated Pin List Added description for Clock Stop Enable feature for Sync ADMux interface.
*E	3217917	OSG	04/06/2011	Changed value of R_USB2 Updated Async SRAM A0 Controlled Read timing diagram Removed Sync ADMux Clock Stop support Updated Sync ADMux interconnect diagram.
*F	3369042	OSG	12/06/2011	Updated tRR and tRPW for crystal input Removed tWZ parameter from Sync ADMux timing Updated SPI timing diagram Updated I2S Timing diagram and tTd parameter Added Note in the Package Diagram section. Corrected ADV# pin mapping in the Pin List Updated Absolute Maximum Ratings In Power Modes description, stated that PVDDQ cannot be turned off at any time if the P-port is used in the application. Added clarification regarding VCC in DC Specifications table Updated I2C interface tVD:ACK parameter for 1 MHz operation Changed datasheet status from Preliminary to Final.
*G	3649782	OSG	08/16/2012	Added note about the I <sup>2</sup> C controller support for clock stretching. Updated Clocking and Hard Reset sections. Modified V <sub>BUS</sub> min value. Updated Rise/fall time max value.

**Document History Page** (continued)

Document Title: CYWB0163BB/CYWB0164BB, West Bridge® Bay™ USB and Mass Storage Controller Document Number: 001-45550				
Revision	ECN	Orig. of Change	Submission Date	Description of Change
*H	3848148	OSG	12/20/2012	Added BGA Pin List and package diagram. Added BGA ball map. Updated ordering information and ordering code diagram.
*I	4016006	OSG	05/31/2013	No content update.
*J	4354719	DBIR	04/21/2014	Updated <a href="#">Package Diagram</a> : spec 001-62221 – Changed revision from *B to *C.  Added <a href="#">Errata</a> .  Updated in new template.

## Sales, Solutions, and Legal Information

### Worldwide Sales and Design Support

Cypress maintains a worldwide network of offices, solution centers, manufacturer's representatives, and distributors. To find the office closest to you, visit us at [Cypress Locations](#).

#### Products

Automotive	<a href="http://cypress.com/go/automotive">cypress.com/go/automotive</a>
Clocks & Buffers	<a href="http://cypress.com/go/clocks">cypress.com/go/clocks</a>
Interface	<a href="http://cypress.com/go/interface">cypress.com/go/interface</a>
Lighting & Power Control	<a href="http://cypress.com/go/powerpsoc">cypress.com/go/powerpsoc</a> <a href="http://cypress.com/go/plc">cypress.com/go/plc</a>
Memory	<a href="http://cypress.com/go/memory">cypress.com/go/memory</a>
PSoC	<a href="http://cypress.com/go/psoc">cypress.com/go/psoc</a>
Touch Sensing	<a href="http://cypress.com/go/touch">cypress.com/go/touch</a>
USB Controllers	<a href="http://cypress.com/go/USB">cypress.com/go/USB</a>
Wireless/RF	<a href="http://cypress.com/go/wireless">cypress.com/go/wireless</a>

#### PSoC® Solutions

[psoc.cypress.com/solutions](http://psoc.cypress.com/solutions)  
PSoC 1 | PSoC 3 | PSoC 4 | PSoC 5LP

#### Cypress Developer Community

[Community](#) | [Forums](#) | [Blogs](#) | [Video](#) | [Training](#)

#### Technical Support

[cypress.com/go/support](http://cypress.com/go/support)

---

© Cypress Semiconductor Corporation, 2009-2014. The information contained herein is subject to change without notice. Cypress Semiconductor Corporation assumes no responsibility for the use of any circuitry other than circuitry embodied in a Cypress product. Nor does it convey or imply any license under patent or other rights. Cypress products are not warranted nor intended to be used for medical, life support, life saving, critical control or safety applications, unless pursuant to an express written agreement with Cypress. Furthermore, Cypress does not authorize its products for use as critical components in life-support systems where a malfunction or failure may reasonably be expected to result in significant injury to the user. The inclusion of Cypress products in life-support systems application implies that the manufacturer assumes all risk of such use and in doing so indemnifies Cypress against all charges.

Any Source Code (software and/or firmware) is owned by Cypress Semiconductor Corporation (Cypress) and is protected by and subject to worldwide patent protection (United States and foreign), United States copyright laws and international treaty provisions. Cypress hereby grants to licensee a personal, non-exclusive, non-transferable license to copy, use, modify, create derivative works of, and compile the Cypress Source Code and derivative works for the sole purpose of creating custom software and or firmware in support of licensee product to be used only in conjunction with a Cypress integrated circuit as specified in the applicable agreement. Any reproduction, modification, translation, compilation, or representation of this Source Code except as specified above is prohibited without the express written permission of Cypress.

Disclaimer: CYPRESS MAKES NO WARRANTY OF ANY KIND, EXPRESS OR IMPLIED, WITH REGARD TO THIS MATERIAL, INCLUDING, BUT NOT LIMITED TO, THE IMPLIED WARRANTIES OF MERCHANTABILITY AND FITNESS FOR A PARTICULAR PURPOSE. Cypress reserves the right to make changes without further notice to the materials described herein. Cypress does not assume any liability arising out of the application or use of any product or circuit described herein. Cypress does not authorize its products for use as critical components in life-support systems where a malfunction or failure may reasonably be expected to result in significant injury to the user. The inclusion of Cypress' product in a life-support systems application implies that the manufacturer assumes all risk of such use and in doing so indemnifies Cypress against all charges.

Use may be limited by and subject to the applicable Cypress software license agreement.