

DESCRIPTION

The CZD5103 is designed for high speed switching applications.

www.DataSheet4U.net

FEATURES

- Low saturation voltage, typically $V_{CE(sat)} = 0.15V$ at $I_C/I_B = 3A/0.15A$
- High speed switching, typically $T_f = 0.1\mu s$ at $I_C = 3A$
- Wide SOA
- Complements to CZD1952

D-Pack (TO-252)

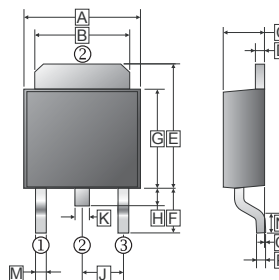
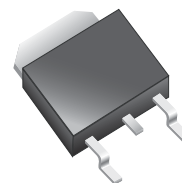

REF.	Millimeter		REF.	Millimeter	
	Min.	Max.		Min.	Max.
A	6.4	6.8	J	2.30 REF.	
B	5.20	5.50	K	0.70	0.90
C	2.20	2.40	M	0.50	1.1
D	0.45	0.58	N	0.9	1.6
E	6.8	7.3	O	0	0.15
F	2.40	3.0	P	0.43	0.58
G	5.40	6.2			
H	0.8	1.20			

MARKING

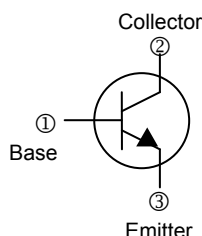
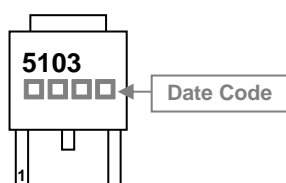

SWITCHING TIME TEST CIRCUIT

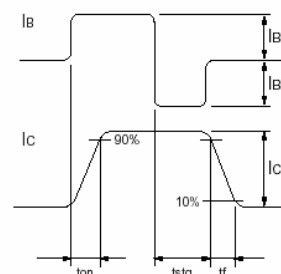
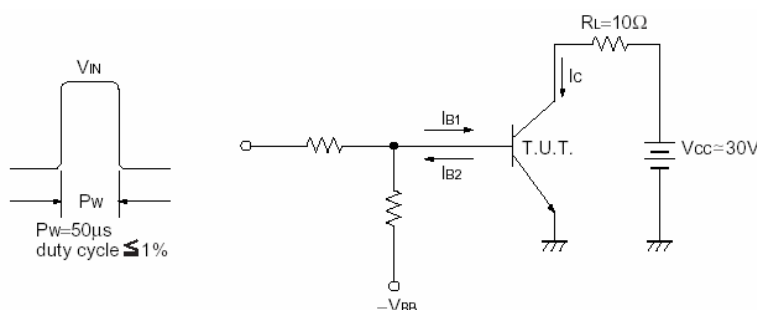

ABSOLUTE MAXIMUM RATINGS (T_A = 25°C)

Parameter	Symbol	Ratings	Unit
Collector to Base Voltage	V_{CBO}	100	V
Collector to Emitter Voltage	V_{CEO}	60	V
Emitter to Base Voltage	V_{EBO}	5	V
Collector Current (DC)	I_C	6	A
Collector Current (Pulse)	I_C	20	A
Total Device Dissipation (T _A =25°C)	P_D	1	W
Total Device Dissipation (T _C =25°C)	P_D	10	W
Junction Temperature	T_J	150	°C
Storage Temperature	T_{STG}	-55 ~ 150	°C

ELECTRICAL CHARACTERISTICS ($T_A = 25^\circ\text{C}$ unless otherwise noted)

Parameter	Symbol	Min.	Typ.	Max.	Unit	Test Conditions
Collector-base breakdown voltage	$V_{(BR)CBO}$	100	-	-	V	$I_C=50\text{ A}, I_E=0$
Collector-emitter breakdown voltage	$V_{(BR)CEO}$	60	-	-	V	$I_C=1\text{mA}, I_B=0$
Emitter-base breakdown voltage	$V_{(BR)EBO}$	5	-	-	V	$I_E=50\text{ A}, I_C=0$
Collector cut-off current	I_{CBO}	-	-	10	A	$V_{CB}=100\text{V}, I_E=0$
Emitter cut-off current	I_{EBO}	-	-	10	A	$V_{EB}=5\text{V}, I_C=0$
Collector-emitter saturation voltage	* $V_{CE(sat)1}$	-	0.15	0.3	V	$I_C=3\text{A}, I_B=0.15\text{A}$
	* $V_{CE(sat)2}$	-	-	0.5	V	$I_C=4\text{A}, I_B=0.2\text{A}$
Base-emitter saturation voltage	* $V_{BE(sat)1}$	-	-	1.2	V	$I_C=3\text{A}, I_B=0.15\text{A}$
	* $V_{BE(sat)2}$	-	-	1.5	V	$I_C=4\text{A}, I_B=0.2\text{A}$
*DC current gain	* h_{FE1}	120	-	270		$V_{CE}=2\text{V}, I_C=1\text{A}$
	* h_{FE2}	40	-	-		$V_{CE}=2\text{V}, I_C=3\text{A}$
Transition frequency	f_T	-	210	-	MHz	$V_{CB}=10\text{V}, I_E=-0.5\text{A}, f=30\text{MHz}$
Output Capacitance	C_{OB}	-	80	-	pF	$V_{CE}=10\text{V}, I_E=0, f=1\text{MHz}$
Turn-On Time	T_{ON}	-	-	0.3	μS	$I_C=3\text{A}, R_L=10\Omega, I_{B1}=-I_{B2}=0.15\text{A}, V_{CC}=30\text{V}$
Storage Time	T_{STG}	-	-	1.5		
Fall Time	T_f	-	0.1	0.3		

*Measured under pulse condition. Pulse width $\leq 300\mu\text{s}$, Duty Cycle $\leq 2\%$

CHARACTERISTIC CURVES

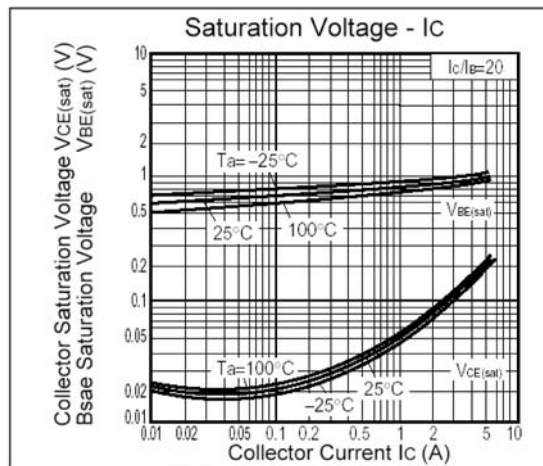
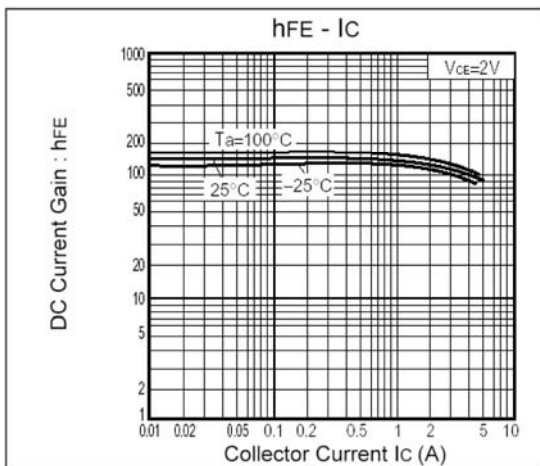
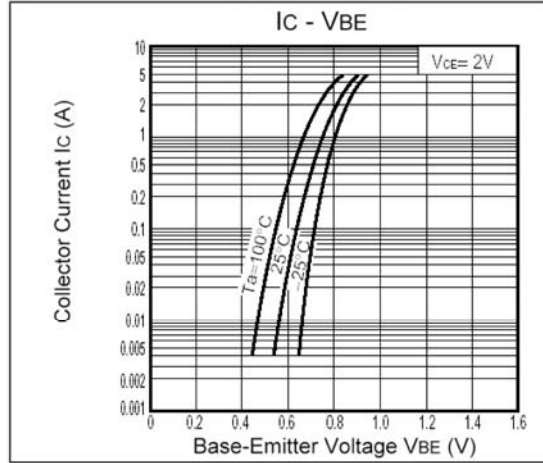
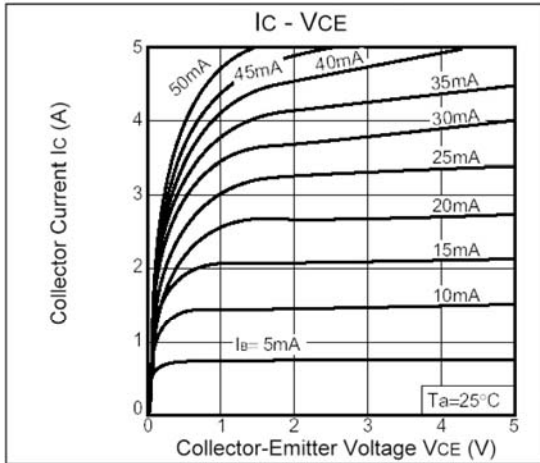

CHARACTERISTIC CURVES

