

PRODUCT SPECIFICATION

DATE: 11/05/1998

COSMO ELECTRONICS CORPORATION	Reed Relay :	NO. 50R02001	REV.
	D1A051000	SHEET 1 OF 2	2

1. OUTSIDE DIMENSION : UNIT (mm)

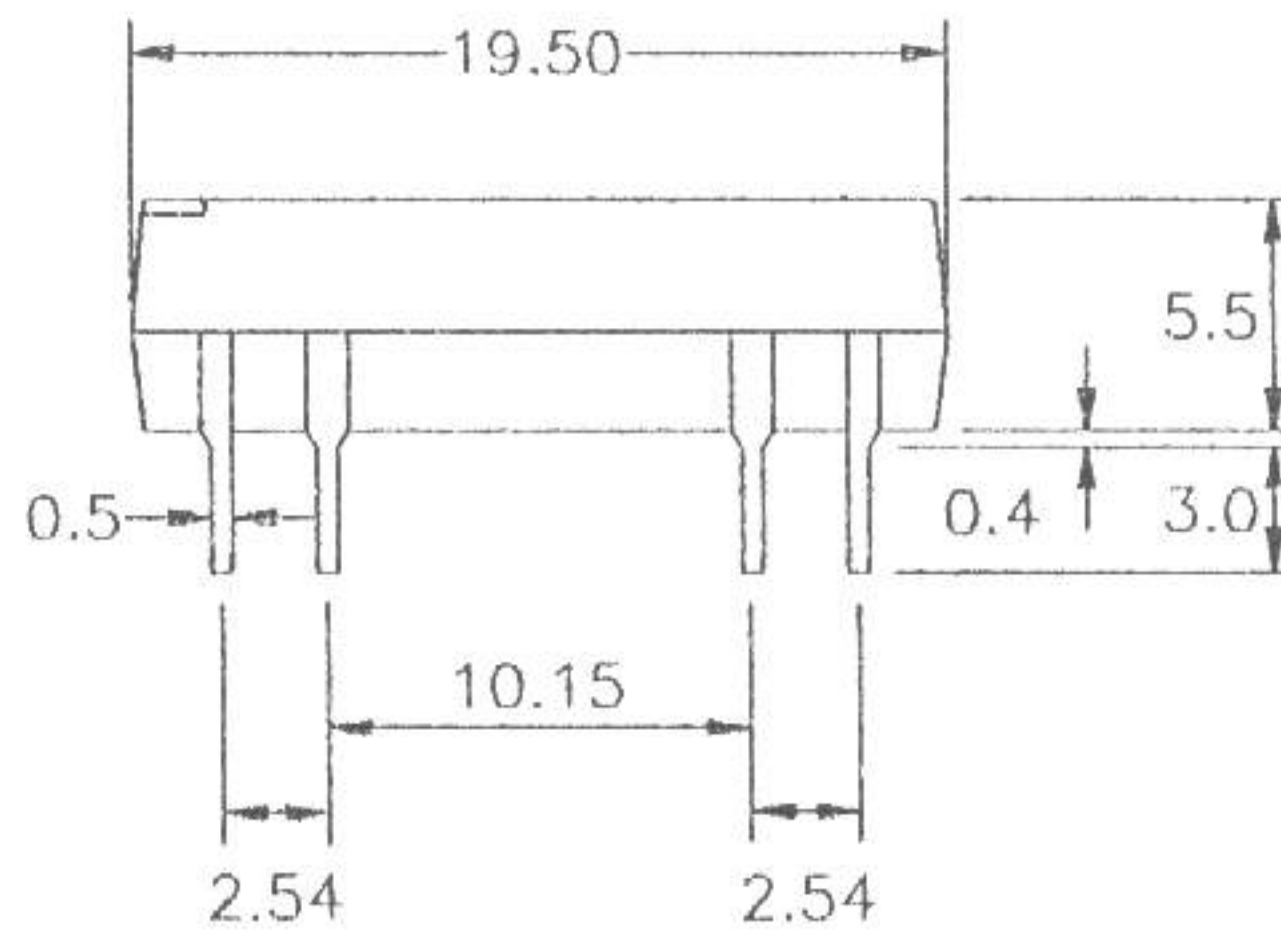
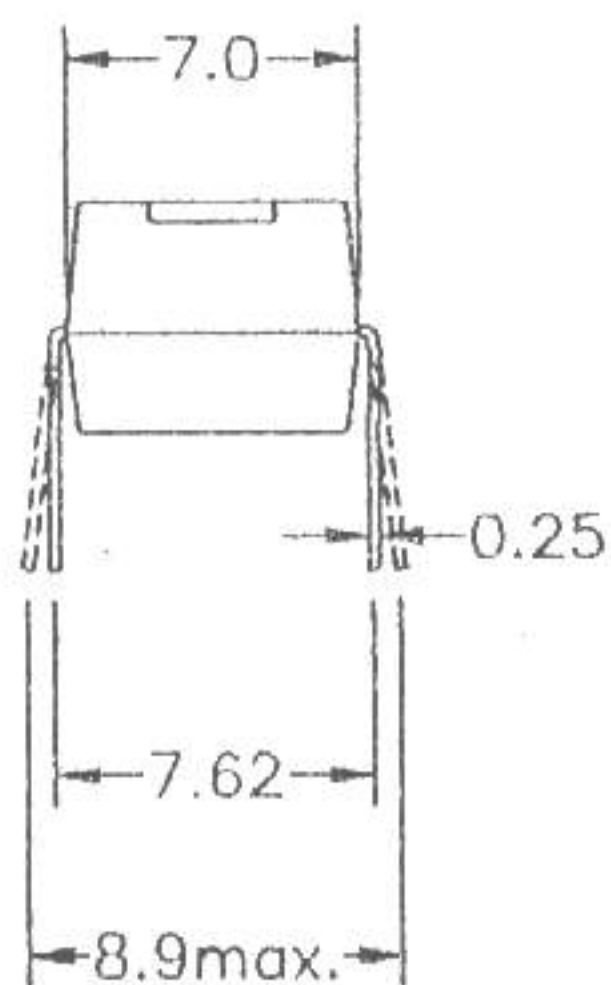
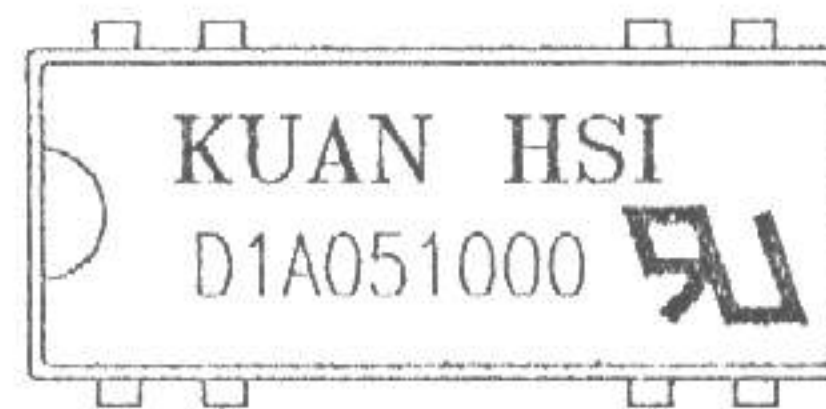

TOLERANCE : $\pm 0.1\text{mm}$

2. SCHEMATIC : TOP VIEW

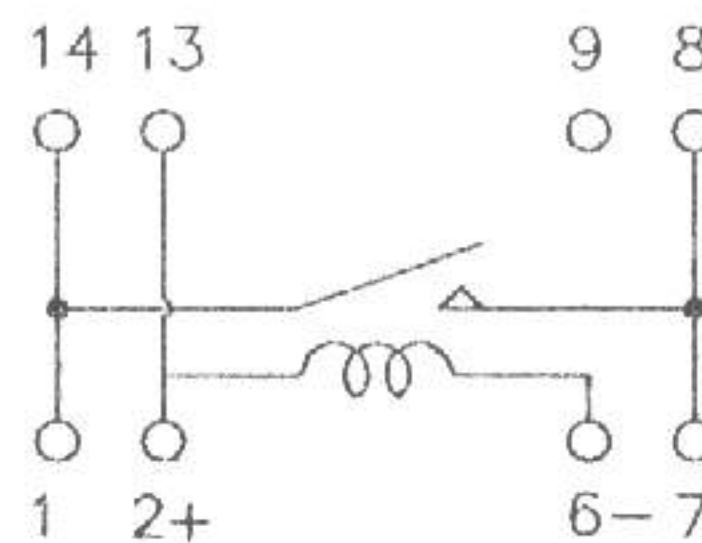

ISSUE <i>Alan Lai</i> 5-11-98	CHECK <i>Alan Lai</i> 5-11-98	APPROVED <i>[Signature]</i> 8/2.5.28
----------------------------------	----------------------------------	---

PRODUCT SPECIFICATION

DATE: 11/05/1998

COSMO ELECTRONICS CORPORATION	Reed Relay : D1A051000	NO. 50R02001 SHEET 2 OF 2	REV. 2
---	---------------------------	------------------------------	------------------

3.0 COIL RATINGS: (AT 20°C)

3.1 Coil resistance	500 ($\Omega \pm 10\%$)
3.2 Nominal coil voltage	5 (VDC)
3.3 Maximum Continuous voltage	10 (VDC)
3.4 Must operate	3.75 (VDC)
3.5 Must release	1.0 (VDC)
3.6 Rated current	10 (mA)

4.0 ELECTRICAL CHARACTERISTICS :

4.1 Contact resistance	100 (m Ω max)
4.2 Operate time	0.5 (mS max)
4.3 Bounce time	0.5 (mS max)
4.4 Release time	0.2 (mS max)
4.5 Insulation resistance (100 VDC open contact)	11 10 (Ω min)
4.6 Power	15 (VA max)
4.7 Switching voltage	200 (VDC max)
4.8 Switching current	1.0 (A max)
4.9 Carry current	1.25 (A max)
4.10 Breakdown voltage (across open contact)	250 (VDC min)
(between coil & contact)	500 (VDC min)
4.11 Life expectancy (signal level)	8 10
4.12 Operating temp.	-40 to 85°C
4.13 Storage temp.	-50 to 125°C
4.14 Resonant frequency	3.5 (KHZ)
4.15 Vibration (10 - 2000 HZ)	20 (g max)
4.16 Minimum permissible load	100 mVDC 10uA

ISSUE *Alan Lui*
5-11-98

CHECK *Alan Lui*
5-11-98

APPROVED *C. Liu*
7.5.98