

PRODUCT SPECIFICATION

DATE: 02/07/94'

KUAN HSI ELECTRONICS CO.,LTD.	Reed Relay : D1C241000	NO. 50R02021	REV. 1
		SHEET 1 OF 2	

1. OUTSIDE DIMENSION : UNIT (mm)

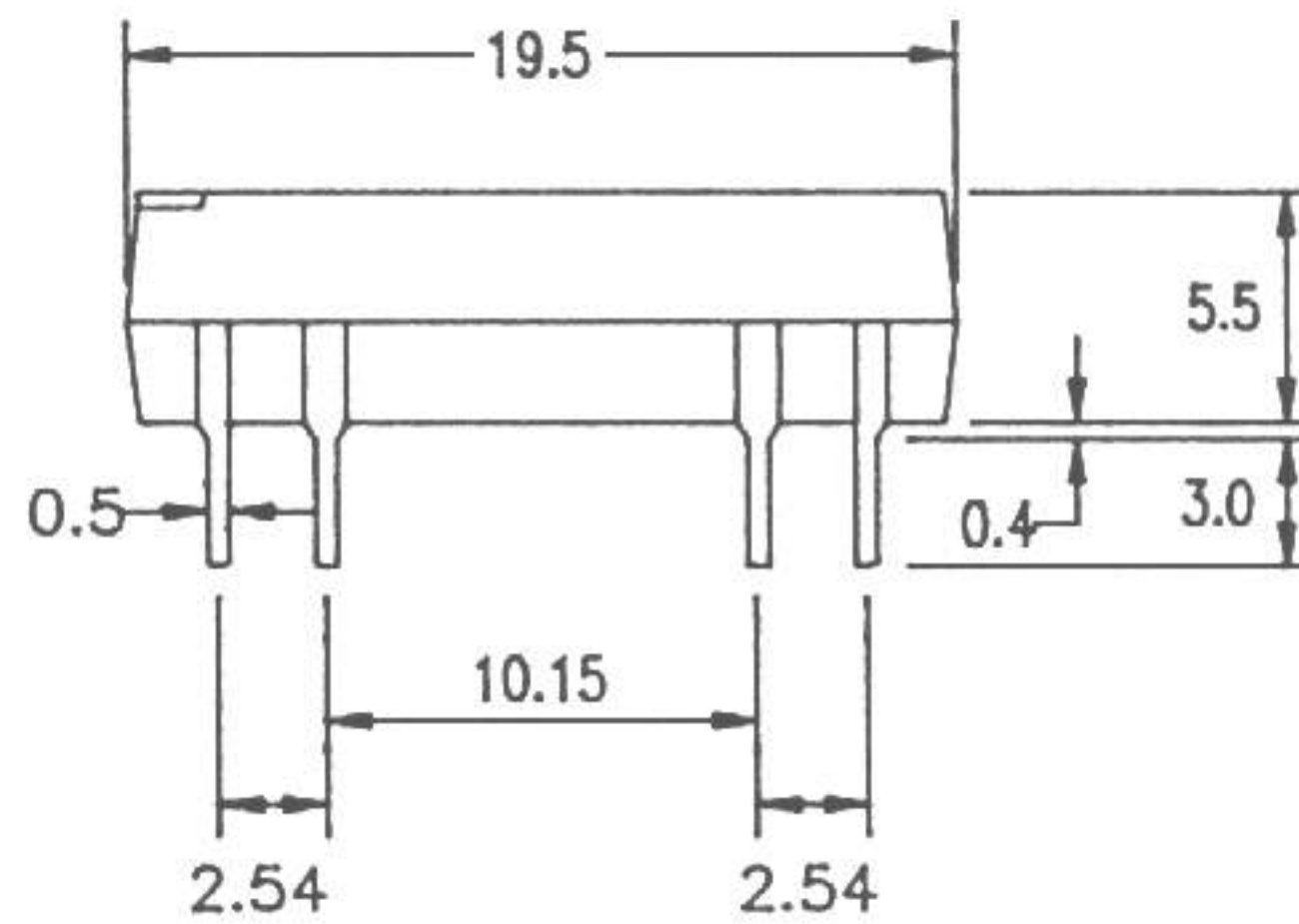
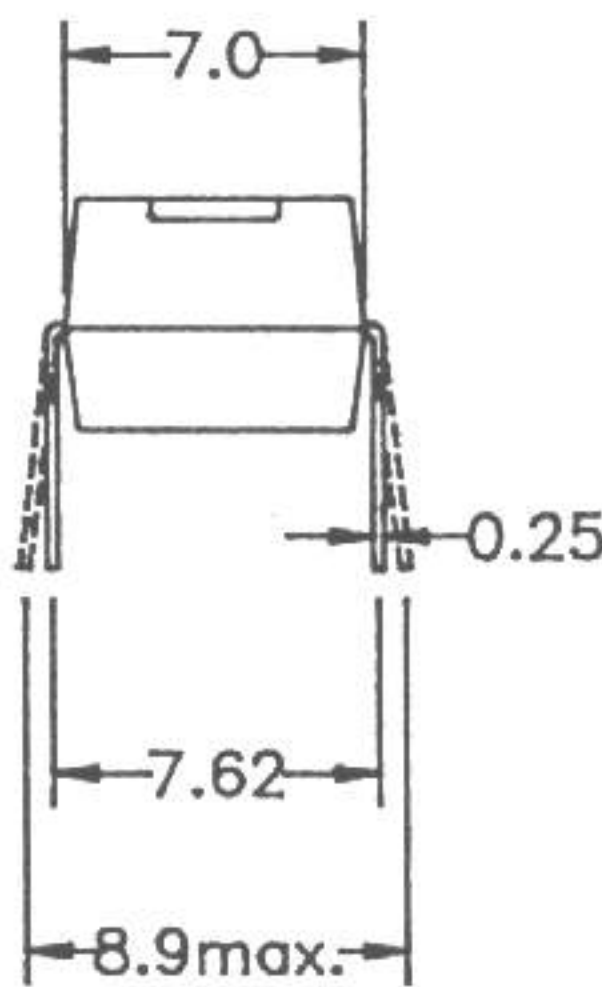

TOLERANCE : $\pm 0.1\text{mm}$

2. SCHEMATIC : TOP VIEW

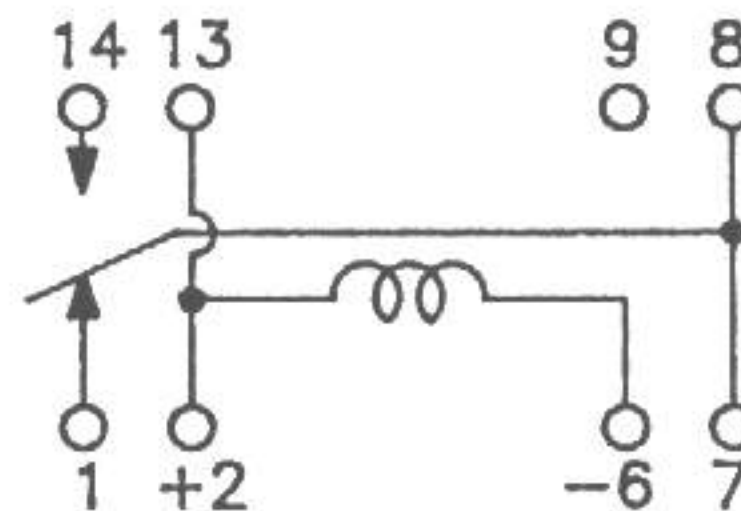

ISSUE **SAM YIIN.**
1-4-1994

CHECK **尹考謙** 3/18
3-18-1994

APPROVED **Eug-Hing** 3/18/94
3-18-1994

PRODUCT SPECIFICATION

DATE: 01/04/94'

KUAN HSI ELECTRONICS CO.,LTD.	Reed Relay : D1C241000	NO. 50R02021 SHEET 2 OF 2	REV. 1
-----------------------------------------	---------------------------	------------------------------	-----------

3.0 COIL RATINGS: (AT 20°C)

3.1	Coil resistance	2150	($\Omega \pm 10\%$)
3.2	Nominal coil voltage	24	(VDC)
3.3	Maximun Continuous voltage	28	(VDC)
3.4	Must operate	18	(VDC)
3.5	Must release	2.4	(VDC)
3.6	Rated current	11.1	(mA)

4.0 ELECTRONICAL CHARACTERISTICS :

4.1	Contact resistance	150	(m Ω max)
4.2	Operate time	1.0	(mS max)
4.3	Bounce time	2.0	(mS max)
4.4	Release time	0.2	(mS max)
4.5	Insulation resistance (100 VDC open contact)	10 ⁷	(Ω min)
4.6	Power	3	(VA max)
4.7	Switching voltage	100	(VDC max)
4.8	Switching current	0.25	(A max)
4.9	Carry current	0.5	(A max)
4.10	Breakdown voltage (across open contact)	200	(VDC min)
	(between coil & contact)	500	(VDC min)
4.11	Life expectancy (signal level)	5X10 ⁷	
4.12	Operating temp.	-40	to 85°C
4.13	Storage temp.	-50	to 125°C
4.14	Resonant frequency	3.5	(KHZ)
4.15	Vibration (10 - 2000 HZ)	20	(g max)
4.16	Minimum permissible load	100mVDC	10uA

ISSUE SAM YIIN 1-4-1994	CHECK 尹若謀 3/18 3-18-1994	APPROVED Super 3/18/94 3-18-1994
-----------------------------------	------------------------------------	--------------------------------------------