



14W Hi-Fi AUDIO AMPLIFIER D2030

GENERAL DESCRIPTION

The D2030 is a monolithic integrated circuit in Pentawatt package, intended for use as a low frequency class AB amplifier. Typically it provides 14W output power ($d = 0.5\%$) at 14V/4Ω; at ±14V or 28V, the guaranteed output power is 12W on a 4Ω load and 8W on a 8Ω (DIN45500).

The D2030 provides high output current and has very low harmonic and cross-over distortion.

Further the device incorporates an original (and patented) short circuit protection system comprising an arrangement for automatically limiting the dissipated power so as to keep the working point of the output transistors within their safe operating area. A conventional thermal shut-down system is also included.

Outline Drawing

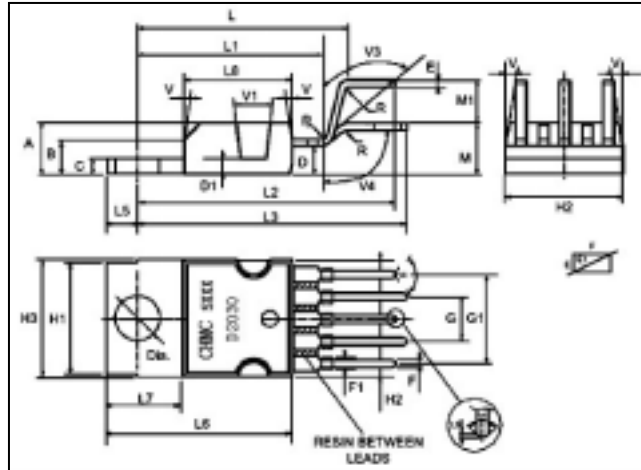

TYPICAL APPLICATION

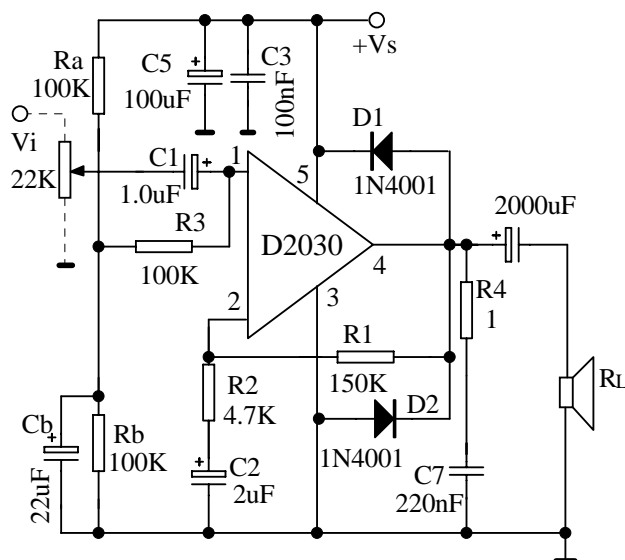

PIN CONNECTION

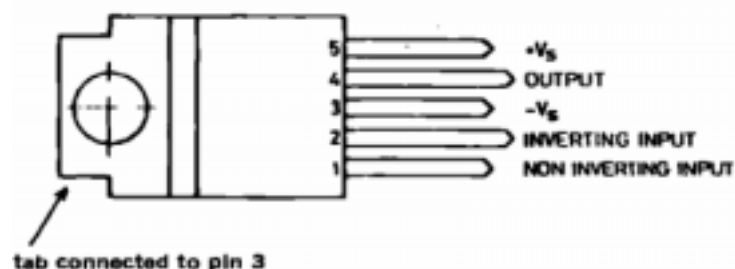

ABSOLUTE MAXIMUM RATINGS (Ta=25°C)

Characteristics	Symbol	Value	Units
Supply Voltage	Vs	±18	V
Input Voltage	Vi	Vs	V
Differential input Voltage	Vdi	±15	V
Peak output Current (Internally limited)	Io	3.5	A
Power Dissipation at Tcase=90°C	Ptot	20	W
Storage Temperature	Tstg	-40~+150	°C
Junction Temperature	Tj	-40~+150	°C

THERMAL DATA

Characteristics	Symbol	Value	Units
Thermal Resistance Junction-case Max	Rth(j-case)	3	°C/W

ELECTRICAL CHARACTERISTICS

(Refer to the test circuit, Vs=±14V, Ta=25°C, unless otherwise specified)

Characteristics	Test conditions	Symbol	Min	Typ	Max	Unit
Supply Voltage		Vs	±6		±18	V
			12		36	
Quiescent Drain Current	Vs=±18V(Vs=36V)	Id		40	60	mA
Input Bias Current		Ib		0.2	2	µA
Input Offset Voltage		Vos		±2	±20	mA
Input Offset Current		Ios		±20	±200	nA

ELECTRICAL CHARACTERISTICS

Continue

Characteristics	Test conditions	Symbol	Min	Typ	Max	Unit	
Output Power	THD=0.5%, $G_v=30\text{dB}$, $f=40$ to 15000Hz	P_o	$R_L=4\Omega$	12	14		W
			$R_L=8\Omega$	8	9		
	THD=10%, $G_v=30\text{dB}$, $f=1\text{kHz}$	$R_L=4\Omega$		18			
		$R_L=8\Omega$		11			
Power Bandwidth (-3dB)	$P_o=12\text{W}$, $R_L=4\Omega$, $G_v=30\text{dB}$	BW	10~140000			kHz	
Open Loop Voltage Gain		G_v		90		dB	
Closed Loop Voltage Gain	$f=1\text{kHz}$	G_v	29.5	30	30.5	dB	
Total Harmonic Distortion	$P_o=0.1$ to 12W , $R_L=4\Omega$, $G_v=30\text{dB}$, $f=40$ to 15000kHz	THD		0.2	0.5	%	
	$P_o=0.1$ to 8W , $R_L=8\Omega$, $G_v=30\text{dB}$, $f=40$ to 15000kHz			0.1	0.5		
Input Noise Voltage	$B=22\text{Hz}$ to 22kHz	e_N		3	10	μV	
Input Noise Current		i_N		80	200	pA	
Input Resistance (pin1)		R_i	0.5	5		M Ω	
Supply Voltage Rejection	$R_L=4\Omega$, $R_g=22\text{k}\Omega$, $G_v=30\text{dB}$, $V_{\text{ripple}}=0.5\text{V}_{\text{eff}}$, $f_{\text{ripple}}=100\text{Hz}$	SVR	40	50		dB	
Drain current	$P_o=14\text{W}$, $R_L=4\Omega$	I_d		900		mA	
	$P_o=8\text{W}$, $R_L=8\Omega$			500			

TEST CIRCUIT

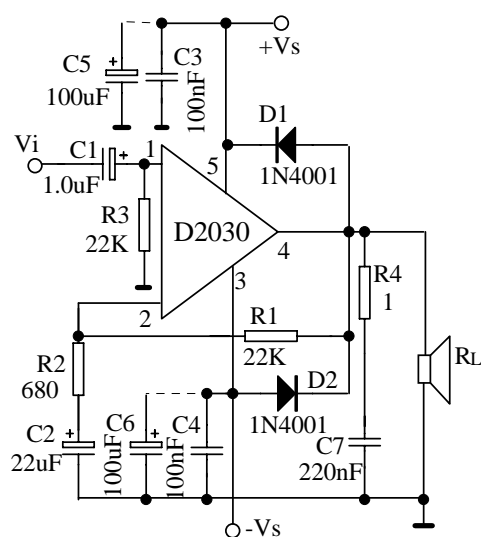

APPLICATION CIRCUIT

1. Typical amplifier with split power supply

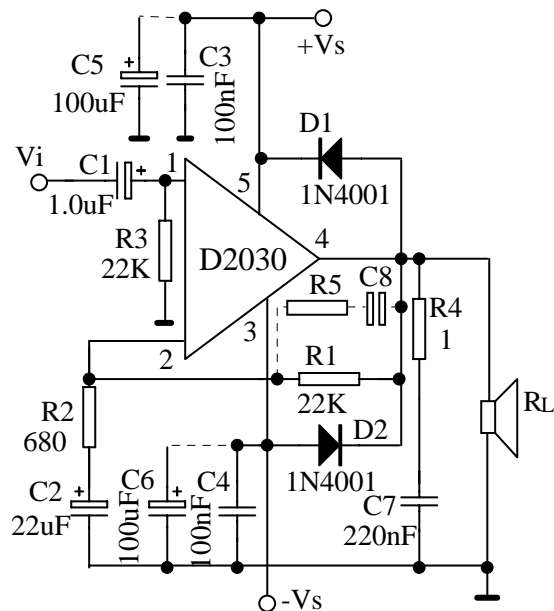

2. Typical amplifier with single power supply

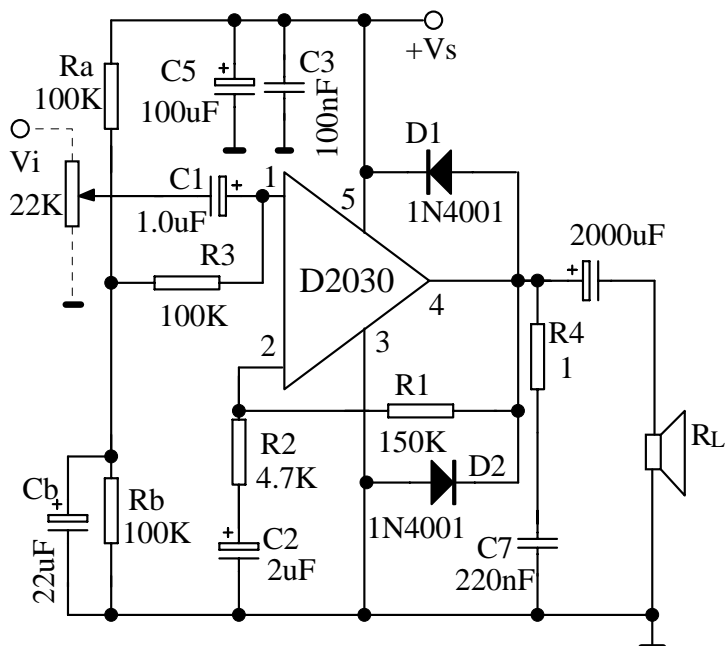

3. Bridge amplifier configuration with split power supply ($P_o=28W$, $V_s=\pm 14V$)

