

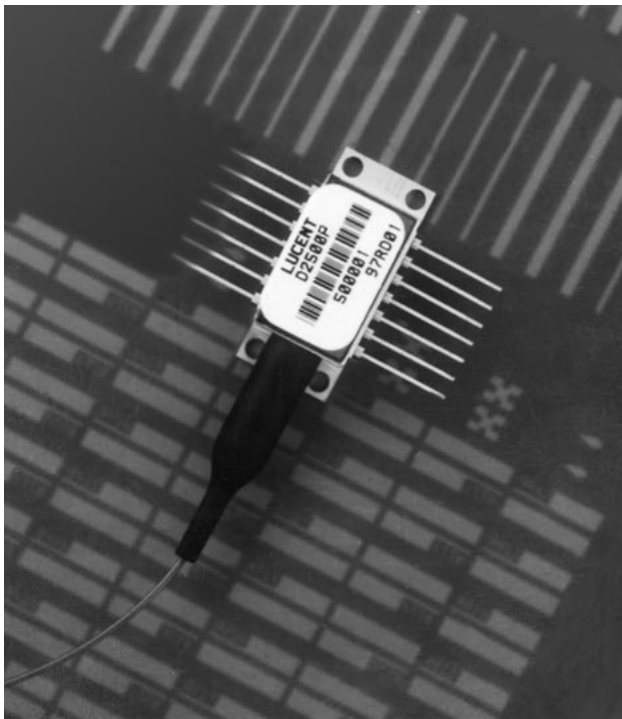

Wavelength-Selected D2525P Isolated DFB Laser Module with PMF



The 1.5 μm D2525P Laser Module is available in a 14-pin, hermetic, butterfly package.

Features

- ITU wavelengths available from 1529.55 nm —1610.06 nm
- Integrated optical isolator
- High-performance, multiquantum-well (MQW), distributed-feedback (DFB) laser
- Industry-standard, 14-pin butterfly package
- Hermetic package
- InGaAs, PIN photodetector back-facet monitor
- Polarization-maintaining fiber pigtail
- For use with lithium niobate modulators
- High reliability
- Narrow linewidth
- High optical power available

Applications

- Telecommunications
 - SONET/SDH OC-48/STM-16, OC-192/STM-64
 - Extended and ultralong reach
 - Undersea systems
 - Dense WDM systems
- Digital video

Description

The D2525P family of DFB laser modules is designed to be used with a lithium niobate external modulator (see Table 4). The laser module features a polarization-maintaining fiber (PMF) pigtail, enabling it to be directly connected to a modulator without the need of a polarization controller. The PMF maintains the polarization of the output light to a consistent orientation. This allows the D2525P to be used as a CW light source for systems requiring extremely low chirp such as undersea or 10 Gbits/s systems. The module contains a multiquantum-well (MQW), distributed-feedback (DFB) laser. This device nominally has an output power of 10 mW. The wavelength of the laser can be temperature-tuned for more precise wavelength selection by adjusting the temperature of the internal thermoelectric cooler.

Description (continued)

Controlled Feedback

The module contains an internal optical isolator that suppresses optical feedback in laser-based, fiber-optic systems. Light reflected back to the laser is attenuated a minimum of 30 dB.

Controlled Temperature

An integral thermoelectric cooler (TEC) provides stable thermal characteristics. The TEC allows for heating and cooling of the laser chip to maintain a temperature of 25 °C for case temperatures from -40 °C to +70 °C. The laser temperature is monitored by the internal thermistor, which can be used with external circuitry to control the laser chip temperature.

Controlled Power

An internal, InGaAs, PIN photodiode functions as the back-facet monitor. The photodiode monitors emission from the rear facet of the laser and, when used in conjunction with control circuitry, can control optical power launched into the fiber. Normally, this configuration is used in a feedback arrangement to maintain consistent laser output power.

Standard Package

The laser module is fabricated in a 14-pin, hermetic, metal/ceramic butterfly package that incorporates a bias tee that separates the dc-bias path from the RF input. The RF input has a nominal 25 Ω impedance.

The laser module is equipped with *Fujikura** polarization-maintaining fiber (PMF). The fiber is PANDA type and is the same fiber that is used on Lucent Technologies Microelectronics Group's lithium niobate modulators. It has a mode field diameter of 10.5 μm, a cladding diameter of 123 μm—128 μm, and a loose tube jacketed fiber 900 μm in diameter. The pigtail is terminated with an *ST*[†] ferrule. Figure 1 shows the orientation of polarization in the fiber.

Lucent's optoelectronic components are being qualified to rigorous internal standards that are consistent with *Telcordia Technologies*[‡] TR-NWT-000468. All design and manufacturing operations are *ISO*[§] 9001 certified. The module is being fully qualified for central office applications.

* *Fujikura* is a registered trademark of Fujikura Ltd.
 † The *ST* ferrule key is not aligned to slow axis of fiber. Connector is intended for testing purposes only.
 ‡ *Telcordia Technologies* is a trademark of Bell Communications Research, Inc.
 § *ISO* is a registered trademark of The International Organization for Standardization.

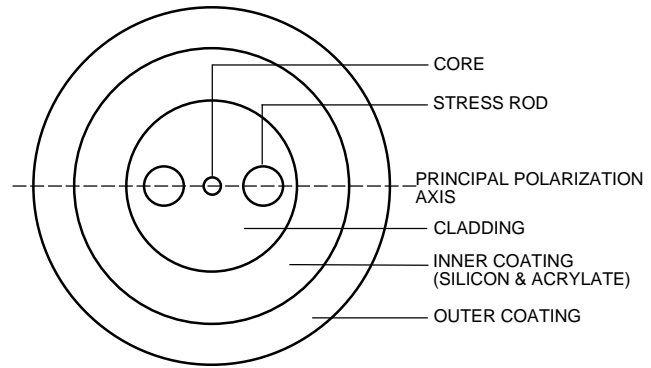

Figure 1. Polarization-Maintaining Fiber

1-771(C).a

Pin Information

Table 1. Pin Descriptions

Pin	Name
1	Thermistor
2	Thermistor
3	Laser dc Bias (Cathode) (-)
4	Back-facet Monitor Anode (-)
5	Back-facet Monitor Cathode (+)
6	Thermoelectric Cooler (+) ¹
7	Thermoelectric Cooler (-) ¹
8	Case Ground
9	Case Ground
10	Case Ground
11	Laser Anode (+) ²
12	RF Laser Input Cathode (-)
13	Laser Anode (+) ²
14	Case Ground

1. A positive current through the thermoelectric heat pump cools the laser.
2. Both leads should be grounded for optimum performance.

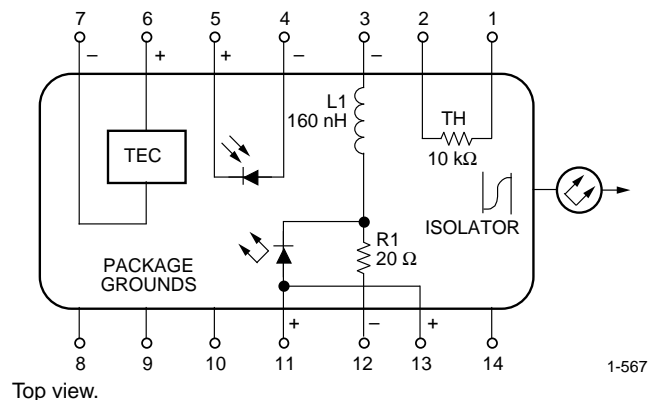

Figure 2. Circuit Schematic

1-567

Absolute Maximum Ratings

Stresses in excess of the absolute maximum ratings can cause permanent damage to the device. These are absolute stress ratings only. Functional operation of the device is not implied at these or any other conditions in excess of those given in the operations sections of the data sheet. Exposure to absolute maximum ratings for extended periods can adversely affect device reliability.

Parameter	Symbol	Min	Max	Unit
Laser Reverse Voltage	VRLMAX	—	2	V
dc Forward Current	IFLMAX	—	225	mA
Operating Case Temperature Range	T _C	-40	70	°C
Storage Case Temperature Range*	T _{stg}	-40	70	°C
Photodiode Reverse Voltage	VRPDMAX	—	10	V
Photodiode Forward Current	IFPDMAX	—	2	mA

* Does not apply to shipping container.

Handling Precautions

Power Sequencing

To avoid the possibility of damage to the laser module from power supply switching transients, follow this turn-on sequence:

1. All ground connections
2. Most negative supply
3. Most positive supply
4. All remaining connections

Reverse the order for the proper turn-off sequence.

Electrostatic Discharge

CAUTION: This device is susceptible to damage as a result of electrostatic discharge. Take proper precautions during both handling and testing. Follow guidelines such as JEDEC Publication No. 108-A (Dec. 1988).

Lucent employs a human-body model (HBM) for ESD-susceptibility testing and protection-design evaluation. ESD voltage thresholds are dependent on the critical parameters used to define the model. A standard HBM (resistance = 1.5 kΩ, capacitance = 100 pF) is widely used and, therefore, can be used for comparison purposes. The HBM ESD threshold presented here was obtained using these circuit parameters:

Parameter	Value	Unit
Human-body Model	>400	V

Mounting Instructions

The minimum fiber bend radius is 1.50 in.

To avoid degradation in performance, mount the module on the board as follows:

1. Place the bottom flange of the module on a flat heat sink at least 0.5 in. x 1.180 in. (12.7 mm x 30 mm) in size. The surface finish of the heat sink should be better than 32 μin. (0.8 μm), and the surface flatness must be better than 0.001 in. (25.4 μm). Using thermal conductive grease is optional; however, thermal performance can be improved by up to 5% if conductive grease is applied between the bottom flange and the heat sink.
2. Mount four #2-56 screws with Fillister heads (M2-3 mm) at the four screw hole locations (see Outline Diagram). The Fillister head diameter must not exceed 0.140 in. (3.55 mm). Do not apply more than 1 in.-lb. of torque to the screws.

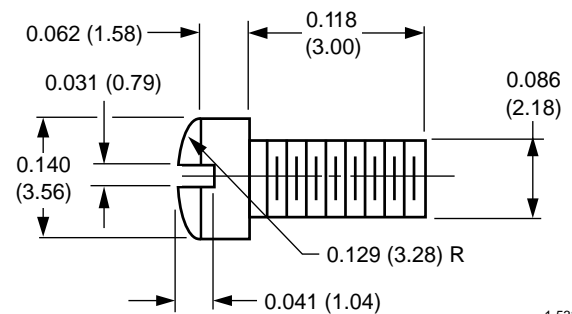

Note: Dimensions are in inches and (millimeters).

Figure 3. Fillister Head Screw

Characteristics

Table 2. Electrical Characteristics (at 25 °C laser temperature)

Parameter	Symbol	Test Conditions	Min	Typ	Max	Unit
Threshold Current	I_{TH}	—	—	15	40	mA
Drive Current Above Threshold	—	$L_F = 10 \text{ mW}$	—	—	110	mA
Laser Forward Voltage	V_{LF}	$L_F = 10 \text{ mW (CW)}$	—	1.3	1.8	V
Monitor Reverse-bias Voltage*	V_{RMON}	—	3	5	10	V
Monitor Current	I_{RMON}	$P_O = 10 \text{ mW (CW)}$	0.200	—	—	mA
Monitor Dark Current	I_D	$I_F = 0, V_{RMON} = 5 \text{ V}$	—	0.01	0.1	μA
Input Impedance	Z_{IN}	—	—	25	—	Ω
Thermistor Current	I_{TC}	—	10	—	100	μA
Resistance Ratio†	—	—	9.1	9.6	10.1	—
Thermistor Resistance	R_{TH}	$T_L = 25 \text{ }^\circ\text{C}$	9.5	—	10.5	k Ω
TEC Current	I_{TEC}	$T_L = 25 \text{ }^\circ\text{C}, T_C = 70 \text{ }^\circ\text{C}$	—	—	1.0	A
TEC Voltage	V_{TEC}	$T_L = 25 \text{ }^\circ\text{C}, T_C = 70 \text{ }^\circ\text{C}$	—	—	2.0	V
TEC Capacity	ΔT	$T_C = 70 \text{ }^\circ\text{C}$	50	—	—	$^\circ\text{C}$

* Standard operating condition is 5.0 V reverse bias.

† Ratio of thermistor resistance at 0 °C to thermistor resistance at 50 °C.

Table 3. Optical Characteristics (at 25 °C laser temperature)

Parameter	Symbol	Test Conditions	Min	Typ	Max	Unit
Peak Optical Output Power	P_P	—	10.0	—	—	mW
Center Wavelength* (See Table 4.)	λ_C	$T_L = 25 \text{ }^\circ\text{C}$ CW Wavelength	1529.55	—	1610.06	nm
Line Width (3 dB full width)	$\Delta\lambda$	CW, $P_F = 10.0 \text{ mW}$	—	2	10	MHz
Relative Intensity Noise	RIN	CW, $P_F = 10.0 \text{ mW}$, $200 \text{ MHz} < f < 10 \text{ GHz}$	—	—	-135	dB/Hz
Side-mode Suppression Ratio	SMSR	CW	33	—	—	dB
Optical Isolation	—	$T_C = 0 \text{ }^\circ\text{C to } 75 \text{ }^\circ\text{C}$	30	—	—	dB
Optical Polarization Extinction Ratio†	—	$0 \text{ }^\circ\text{C to } 75 \text{ }^\circ\text{C}$	20	—	—	dB

* Custom wavelengths available.

† The ST ferrule key is not aligned to slow axis of fiber. Connector is intended for testing purposes only.

Outline Diagram

Dimensions are in inches and (millimeters). Tolerances are ± 0.005 in. (± 0.127 mm).

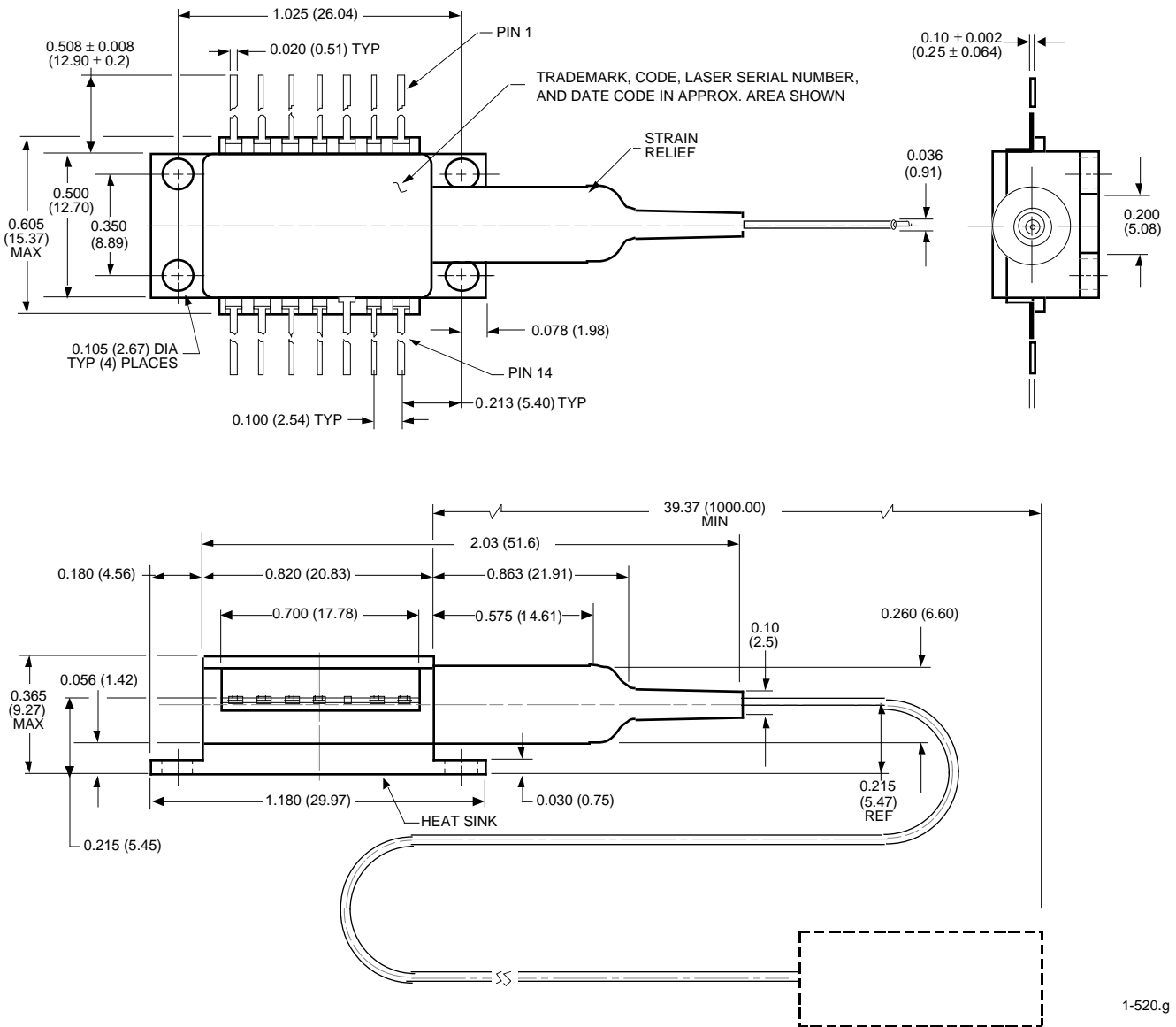

1-520.g

High-Power Product

Class IIIb Laser Product

FDA/CDRH Class IIIb laser product. All versions are Class IIIb laser products per CDRH, 21 CFR 1040 Laser Safety requirements. All versions are Class IIIb laser products per *IEC** 60825-1:1993. The device has been certified with the FDA under accession number 8720010.

This product complies with 21 CFR 1040.10 and 1040.11.

8 μm /123 μm —128 μm single-mode fiber with 900 μm loose-tube jacketed fiber and connector

Wavelength = 1.5 μm

Maximum power = 40 mW

Because of size constraints, laser safety labeling is not affixed to the module but attached to the outside of the shipping carton.

Product is not shipped with power supply.

Caution: Use of controls, adjustments, and procedures other than those specified herein may result in hazardous laser radiation exposure.

* *IEC* is a registered trademark of The International Electrotechnical Commission.

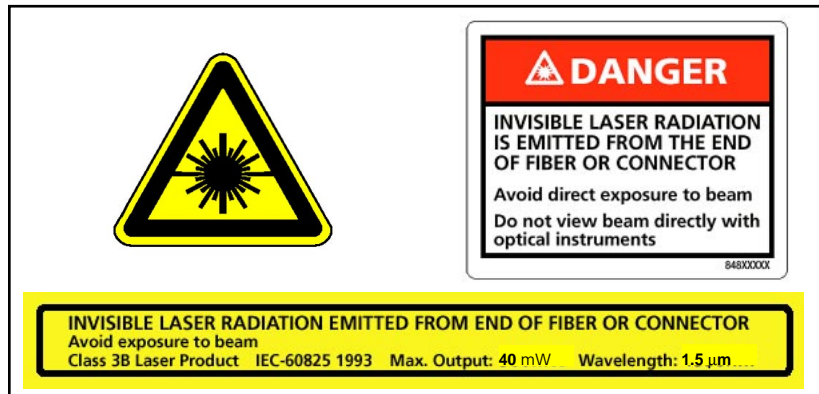

Ordering Information

Table 4. Ordering Information

Device Code	Comcode	ITU Frequency	Wavelength	Tolerance
D2525P862	108575085	186.2	1610.06	±0.4 nm
D2525P863	108575093	186.3	1609.19	±0.4 nm
D2525P864	108575119	186.4	1608.33	±0.4 nm
D2525P865	108575127	186.5	1607.47	±0.4 nm
D2525P866	108575135	186.6	1606.60	±0.4 nm
D2525P867	108575143	186.7	1605.74	±0.4 nm
D2525P868	108575150	186.8	1604.88	±0.4 nm
D2525P869	108575168	186.9	1604.33	±0.4 nm
D2525P870	108575184	187.0	1603.17	±0.4 nm
D2525P871	108476227	187.1	1602.31	±0.4 nm
D2525P872	108476235	187.2	1601.45	±0.4 nm
D2525P873	108476243	187.3	1600.60	±0.4 nm
D2525P874	108476250	187.4	1599.75	±0.4 nm
D2525P875	108476268	187.5	1598.89	±0.4 nm
D2525P876	108476276	187.6	1598.04	±0.4 nm
D2525P877	108476284	187.7	1597.19	±0.4 nm
D2525P878	108476292	187.8	1596.34	±0.4 nm
D2525P879	108476300	187.9	1595.49	±0.4 nm
D2525P880	108476318	188.0	1594.64	±0.4 nm
D2525P881	108476326	188.1	1593.79	±0.4 nm
D2525P882	108476334	188.2	1592.95	±0.4 nm
D2525P883	108476342	188.3	1592.10	±0.4 nm
D2525P884	108476359	188.4	1591.25	±0.4 nm
D2525P885	108476367	188.5	1590.41	±0.4 nm
D2525P886	108476375	188.6	1589.57	±0.4 nm
D2525P887	108476383	188.7	1588.72	±0.4 nm
D2525P888	108476391	188.8	1587.88	±0.4 nm
D2525P889	108476409	188.9	1587.04	±0.4 nm
D2525P890	108476417	189.0	1586.20	±0.4 nm
D2525P891	108476425	189.1	1585.36	±0.4 nm
D2525P892	108476433	189.2	1584.53	±0.4 nm
D2525P893	108476441	189.3	1583.69	±0.4 nm
D2525P894	108476458	189.4	1582.85	±0.4 nm
D2525P895	108476516	189.5	1582.02	±0.4 nm
D2525P896	108476524	189.6	1581.18	±0.4 nm
D2525P897	108476540	189.7	1580.35	±0.4 nm
D2525P898	108476557	189.8	1579.52	±0.4 nm
D2525P899	108476573	189.9	1578.69	±0.4 nm

Ordering Information (continued)

Table 4. Ordering Information (continued)

Device Code	Comcode	ITU Frequency	Wavelength	Tolerance
D2525P900	108476581	190.0	1577.85	±0.4 nm
D2525P901	108476599	190.1	1577.02	±0.4 nm
D2525P902	108476615	190.2	1576.20	±0.4 nm
D2525P903	108476623	190.3	1575.37	±0.4 nm
D2525P904	108476631	190.4	1574.54	±0.4 nm
D2525P905	108476649	190.5	1573.71	±0.4 nm
D2525P906	108476656	190.6	1572.89	±0.4 nm
D2525P907	108476664	190.7	1572.06	±0.4 nm
D2525P908	108476672	190.8	1571.24	±0.4 nm
D2525P909	108476680	190.9	1570.42	±0.4 nm
D2525P910	108476698	191.0	1569.59	±0.4 nm
D2525P911	108476706	191.1	1568.77	±0.4 nm
D2525P912	108476714	191.2	1567.95	±0.4 nm
D2525P913	108476722	191.3	1567.13	±0.4 nm
D2525P914	108476730	191.4	1566.31	±0.4 nm
D2525P915	108512534	191.5	1565.50	±0.4 nm
D2525P916	108512542	191.6	1564.68	±0.4 nm
D2525P17	108196098	191.7	1563.86	±0.4 nm
D2525P18	108196106	191.8	1563.05	±0.4 nm
D2525P19	108002452	191.9	1562.23	±0.4 nm
D2525P20	108002460	192.0	1561.42	±0.4 nm
D2525P21	108002478	192.1	1560.61	±0.4 nm
D2525P22	108002486	192.2	1559.79	±0.4 nm
D2525P23	108002494	192.3	1558.98	±0.4 nm
D2525P24	108002502	192.4	1558.17	±0.4 nm
D2525P25	108002510	192.5	1557.36	±0.4 nm
D2525P26	108002528	192.6	1556.55	±0.4 nm
D2525P27	108002536	192.7	1555.75	±0.4 nm
D2525P28	108002544	192.8	1554.94	±0.4 nm
D2525P29	108002551	192.9	1554.13	±0.4 nm
D2525P30	108002569	193.0	1553.33	±0.4 nm
D2525P31	108002577	193.1	1552.52	±0.4 nm
D2525P32	108002585	193.2	1551.72	±0.4 nm
D2525P33	108002593	193.3	1550.92	±0.4 nm
D2525P34	108002601	193.4	1550.12	±0.4 nm
D2525P35	108003039	193.5	1549.32	±0.4 nm
D2525P36	108003047	193.6	1548.51	±0.4 nm
D2525P37	108003054	193.7	1547.72	±0.4 nm
D2525P38	108003062	193.8	1546.92	±0.4 nm
D2525P39	108003070	193.9	1546.12	±0.4 nm

Ordering Information (continued)

Table 4. Ordering Information (continued)

Device Code	Comcode	ITU Frequency	Wavelength	Tolerance
D2525P40	108003088	194.0	1545.32	±0.4 nm
D2525P41	108003096	194.1	1544.53	±0.4 nm
D2525P42	108003104	194.2	1543.73	±0.4 nm
D2525P43	108003112	194.3	1542.94	±0.4 nm
D2525P44	108003120	194.4	1542.14	±0.4 nm
D2525P45	108003138	194.5	1541.35	±0.4 nm
D2525P46	108003146	194.6	1540.56	±0.4 nm
D2525P47	108003153	194.7	1539.77	±0.4 nm
D2525P48	108003161	194.8	1538.98	±0.4 nm
D2525P49	108003179	194.9	1538.19	±0.4 nm
D2525P50	108003187	195.0	1537.40	±0.4 nm
D2525P51	108003195	195.1	1536.61	±0.4 nm
D2525P52	108003203	195.2	1535.82	±0.4 nm
D2525P53	108003211	195.3	1535.04	±0.4 nm
D2525P54	108003229	195.4	1534.25	±0.4 nm
D2525P55	108003237	195.5	1533.47	±0.4 nm
D2525P56	108003245	195.6	1532.68	±0.4 nm
D2525P57	108196114	195.7	1531.90	±0.4 nm
D2525P58	108196122	195.8	1531.12	±0.4 nm
D2525P59	108196130	195.9	1530.33	±0.4 nm
D2525P60	108196148	196.0	1529.55	±0.4 nm

For additional information, contact your Microelectronics Group Account Manager or the following:

INTERNET: <http://www.lucent.com/micro>, or for Optoelectronics information, <http://www.lucent.com/micro/opto>
E-MAIL: docmaster@micro.lucent.com
N. AMERICA: Microelectronics Group, Lucent Technologies Inc., 555 Union Boulevard, Room 30L-15P-BA, Allentown, PA 18103
1-800-372-2447, FAX 610-712-4106 (In CANADA: **1-800-553-2448**, FAX 610-712-4106)
ASIA PACIFIC: Microelectronics Group, Lucent Technologies Singapore Pte. Ltd., 77 Science Park Drive, #03-18 Cintech III, Singapore 118256
Tel. (65) 778 8833, FAX (65) 777 7495
CHINA: Microelectronics Group, Lucent Technologies (China) Co., Ltd., A-F2, 23/F, Zao Fong Universe Building, 1800 Zhong Shan Xi Road, Shanghai 200233 P. R. China **Tel. (86) 21 6440 0468, ext. 316**, FAX (86) 21 6440 0652
JAPAN: Microelectronics Group, Lucent Technologies Japan Ltd., 7-18, Higashi-Gotanda 2-chome, Shinagawa-ku, Tokyo 141, Japan
Tel. (81) 3 5421 1600, FAX (81) 3 5421 1700
EUROPE: Data Requests: MICROELECTRONICS GROUP DATALINE: **Tel. (44) 7000 582 368**, FAX (44) 1189 328 148
Technical Inquiries: OPTOELECTRONICS MARKETING: **(44) 1344 865 900** (Ascot UK)

Lucent Technologies Inc. reserves the right to make changes to the product(s) or information contained herein without notice. No liability is assumed as a result of their use or application. No rights under any patent accompany the sale of any such product(s) or information. *ST* is a registered trademark of Lucent Technologies Inc.

