

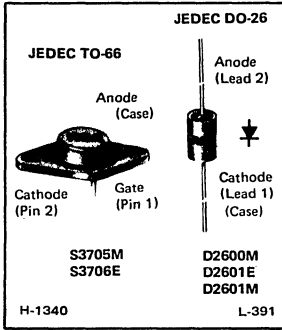

Thyristors/Rectifiers

S3705M D2600M
S3706E D2601E
D2601M



SCR's and Rectifiers for Horizontal-Deflection Circuits

For Large-Screen Color TV

Features:

- Ability to handle high beam current; average 1.6 mA dc
- Ability to supply as much as 5 mJ of stored energy to the deflection yoke, which is sufficient for 29-mm-neck and 36.5-mm-neck picture tubes operated at 29 kV (nominal value)
- Highly reliable circuit which can also be used as a low-voltage power supply

Package	Voltage	
	600 V Types	500 V Types
TO-66	S3705M	S3706E
DO-26	D2600M, D2601M	D2601E

These RCA types are designed for use in a horizontal output circuit such as that shown in Fig. 1.

The S3705M silicon controlled rectifier and the D2601M silicon rectifier are designed to act as a bipolar switch that controls horizontal yoke current during the beam trace interval. The S3706E silicon controlled rectifier and the D2601E silicon

rectifier act as the commutating switch to initiate trace-retrace switching and control yoke current during retrace.

The D2600M silicon rectifier may be used as a clamp to protect the circuit components from excessively high transient voltages which may be generated as a result of arcing in the picture tube or in a high-voltage rectifier tube.

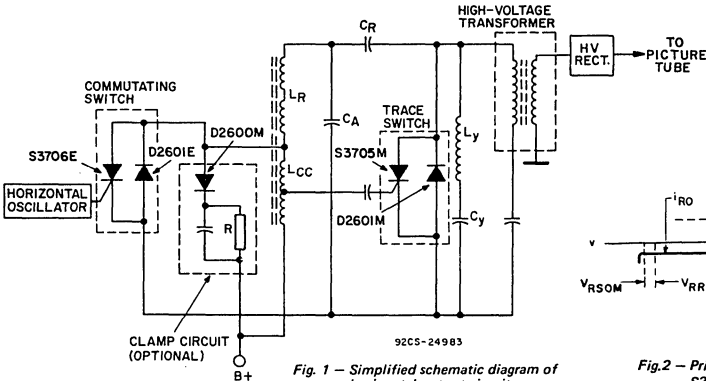

Fig. 1 - Simplified schematic diagram of horizontal output circuit.

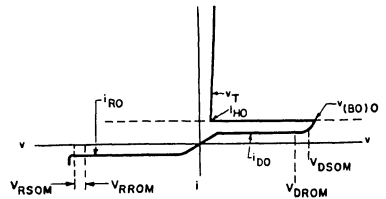

Fig. 2 - Principal voltage-current characteristic for S3705M and S3706E.

SILICON CONTROLLED RECTIFIERS

MAXIMUM RATINGS, Absolute-Maximum Values:

NON-REPETITIVE PEAK OFF-STATE VOLTAGE:[•]

Gate Open V_{DSOM} 700* 600* V

REPETITIVE PEAK REVERSE VOLTAGE:[•]

Gate Open V_{RRM} 25 25 V

REPETITIVE PEAK OFF-STATE VOLTAGE:[•]

Gate Open V_{DROM} 600 500 V

ON-STATE CURRENT:

$T_C = 60^\circ C$, 60 Hz sine wave, conduction angle = 180° .

RMS $I_T(RMS)$ 5 5 A

Average DC $I_T(AV)$ 3.2 3.2 A

PEAK SURGE (NON-REPETITIVE) ON-STATE CURRENT:

For one full cycle of applied principal voltage

60 Hz (sinusoidal), $T_C = 60^\circ C$ 80 A

50 Hz (sinusoidal), $T_C = 60^\circ C$ 65 A

For one-half sine wave, 3 ms pulse width 150 A

RATE OF CHANGE OF ON-STATE CURRENT:

$V_D = V_{DROM}$, $I_{GT} = 50$ mA, $t_r = 0.1$ μs di/dt 200 A/ μs

FUSING CURRENT (for SCR protection):

$T_J = -40$ to $80^\circ C$, $t = 1$ to 10 ms $I^2 t$ 20 A²s

GATE POWER DISSIPATION:[•]

Peak (forward or reverse) for 10 μs duration, max.

negative gate bias = -35 V (S3705M) 25 W

= -10 V (S3706E) 25 W

TEMPERATURE RANGE:[•]

Storage T_{stg} -40 to 150 $^\circ C$

Operating (Case) T_C -40 to 80 $^\circ C$

PIN TEMPERATURE (During soldering):

At distances $\geq 1/32$ in. (0.8 mm) from seating plane

for 10 s max. T_p 225 225 $^\circ C$

S3705M
TRACE SCR
S3706E
COMMUTATING SCR

[•]Protection against transients above these values induced by arcing or other causes must be provided.

[•]These values do not apply if there is a positive gate signal. Gate must be open or negatively biased.

[•]Any product of gate current and gate voltage which results in a gate power less than the maximum is permitted, provided that the maximum reverse gate bias (as specified) is not exceeded.

[•]For temperature measurement reference point, see Dimensional Outline.

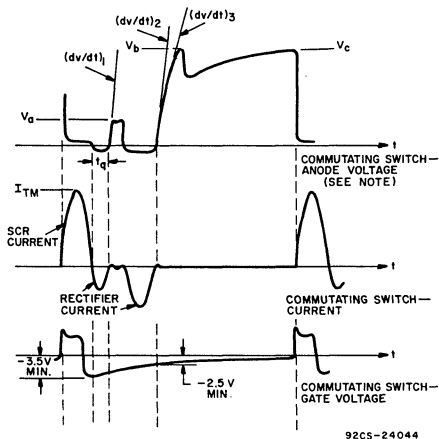

NOTE: "Commutating Switch-Anode Voltage" oscilloscope display has been modified graphically to show the measurement points of dv/dt more effectively.

$I_{TM} = 15$ A, $V_a = 100$ V max., $V_b = 250$ V max., $V_c = 400$. Gate voltage = 12 V positive from 15 V supply. Gate current should rise to 100 mA within 0.2 μs . Minimum duration of gate current pulse = 3 μs . Minimum amplitude of gate current pulse = 200 mA. Negative gate bias at turn-off = -3.5 V minimum, negative gate bias at 2nd reapplied voltage $(dv/dt)_2 = -2.5$ V minimum.

$(dv/dt)_1 = 400$ V/ μs (measured tangent to waveform at 0.8 of V_a)

$(dv/dt)_2 = 1000$ V/ μs (measured tangent to waveform at 0.3 of V_b)

$(dv/dt)_3 = 700$ V/ μs (measured tangent to waveform at 0.8 of V_b)

92CS-24044

Fig.3 - Oscilloscope display of commutating switching (S3706E) showing circuit-commutated turn-off time (t_q).

SILICON CONTROLLED RECTIFIERS

ELECTRICAL CHARACTERISTICS

At Maximum Ratings Unless Otherwise Specified and at Indicated Case Temperature (T_C)

CHARACTERISTIC	SYMBOL	LIMITS				UNITS
		S3705M		S3706E		
		TRACE SCR	COMMUTATING SCR	TYP.	MAX.	
Peak Forward Off-State Current: Gate open, $V_D = V_{DROM}$, $T_C = 85^\circ C$. .	I_{DOM}	0.5	1.5	0.5	1.5	mA
Instantaneous On-State Voltage: $i_T = 30$ A (peak), $T_C = 25^\circ C$	V_T	2.2	3	2.2	3	V
Critical Rate of Rise of Off-State Voltage: $V_D = V_{DROM}$, exponential voltage rise, $T_C = 70^\circ C$	dv/dt	175 (min.) (See Fig.4)		1000 (min.) $(dv/dt)_2$ (See Fig.3)		V/ μs
DC Gate Trigger Current: $V_D = 12$ V (dc), $R_L = 30 \Omega$, $T_C = 25^\circ C$	I_{GT}	15	32	15	45	mA
DC Gate Trigger Voltage: $V_D = 12$ V (dc), $R_L = 30 \Omega$, $T_C = 25^\circ C$	V_{GT}	1.8	4	1.8	4	V
Circuit Commutated Turn-Off Time: \blacklozenge $T_C = 70^\circ C$, minimum negative gate bias during turn-off time = -20 V (S3705M) and -2.5 V (S3706E), rate of reapplied voltage (dv/dt) = 175 V/ μs (See Fig. 4) = 400 V/ μs (See Fig. 3)	t_q	—	2.5	—	— 4.5	μs μs
Thermal Resistance, Junction-to-Case . . .	$R_{\theta JC}$	—	4	—	4	$^\circ C/W$

\blacklozenge This parameter, the sum of reverse recovery time and gate recovery time, is measured from the zero crossing of current to the start of the reapplied voltage. Knowledge of the current, the reapplied voltage, and the case temperature is necessary when measuring t_q . In the worst conditions (high line, zero-beam, off-frequency, minimum auxiliary load, etc.), turn-off time must not fall below the given values. Turn-off time increases with temperature, therefore, case temperature must not exceed $70^\circ C$. See Figs. 3 and 4.

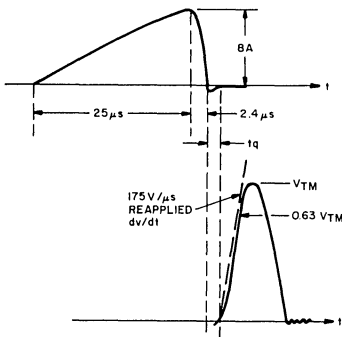

$I_{TM} = 8$ A, $V_{TM} = V_{DROM}$, reapplied $dv/dt = 175$ V/ μs (measured from 0 to 0.63 of V_{TM}), negative gate voltage source = -24 V, source impedance = 15Ω .

92CS-24045

Fig. 4 - Oscilloscope display of trace switching (S3705M) showing circuit-commutating turn-off time (t_q).

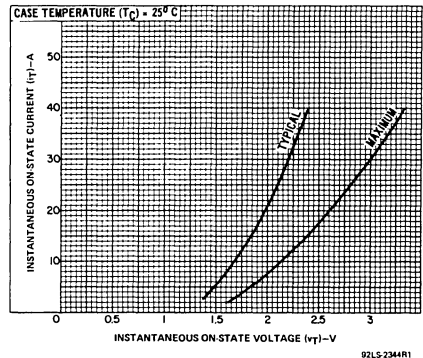

92LS-2344R1

Fig. 5 - Instantaneous on-state current vs. on-state voltage for S3705M and S3706E.

SILICON RECTIFIERS

MAXIMUM RATINGS, *Absolute-Maximum Values:*

		D2601M TRACE	D2601E COMMUTATING	D2600M CLAMP	
REVERSE VOLTAGE:**					
Repetitive Peak	V _{RRM}	600	500	600	V
Non-Repetitive Peak**	V _{RSM}	700	600	700	V
FORWARD CURRENT (operating in 15 kHz deflection circuit):					
RMS	I _{F(RMS)}	1.9**	1.6**	0.5**	A
Peak Surge (Non-Repetitive)**	I _{FSM}	70 ^{▲▲}	70 ^{▲▲}	30 ^{▲▲}	A
Peak (Repetitive)	I _{FRM}	6.5	6	0.5	A
TEMPERATURE RANGE					
Storage	T _{stg}	-30 to 150			°C
Operating (Case)	T _C	-30 to 80			°C
LEAD TEMPERATURE (During Soldering):					
Measured 1/8 in. (3.17 mm) from case for 10 s maximum	T _L	225			°C

** For ambient temperatures up to 45°C.

•• For a maximum of 3 pulses, each less than 10 μs duration, during any 64-μs period.

■ Maximum current rating applies only if the rectifier is properly mounted to maintain junction temperature below 150°C.

▲▲ See Fig.9 for I_{FSM} value for 50 and 60 Hz operation.

SILICON RECTIFIERS

ELECTRICAL CHARACTERISTICS

CHARACTERISTIC	SYMBOL	LIMITS		UNITS	
		D2601M D2601E	TRACE COMMUT.		D2600M CLAMP
		MAXIMUM			MAXIMUM
Reverse Current: <i>Static</i> For V _{RRM} = max. rated value, I _F = 0, T _C = 25°C	I _{RM}	10		10	μA
For V _R = 500 V, T _C = 100°C		250		250	
Instantaneous Forward Voltage Drop: At I _F = 4 A, T _A = 25°C	V _F	1.9		2	V
Reverse Recovery Time: For circuit shown in Fig. 8: At I _{FM} = 20 A, -di _F /dt = -20 A/μs, pulse duration = 2.8 μs, T _C = 25°C	t _{rr}	0.5		0.7	μs
In Tektronix type "S" plug-in unit (or equivalent): At I _F = 20 mA, I _R = 1 mA, T _C = 25°C		1.2		1.5	
Peak Forward Voltage Drop (at turn-on): In Tektronix type "S" plug-in unit (or equivalent): At I _F = 20 mA, T _C = 25°C	V _{F(pk)}	5		6	V
Thermal Resistance (Junction-to-Lead)♦ (See Fig.14)	R _{θJL}	45		45	°C/W

♦ Measured on anode lead 1/8 in. (3.18 mm) from case.

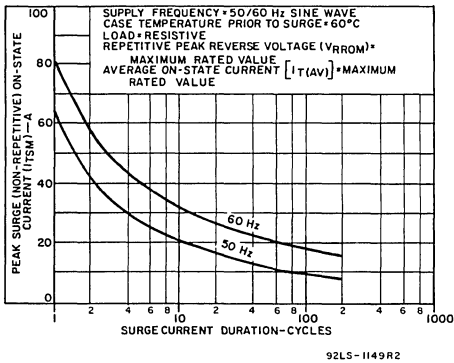

Fig. 6 — Peak surge on-state current vs. surge current duration for S3705M and S3706E.

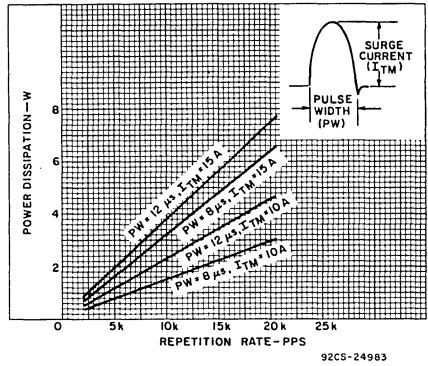

Fig. 7 — Dissipation vs. repetition rate for S3705M and S3706E.

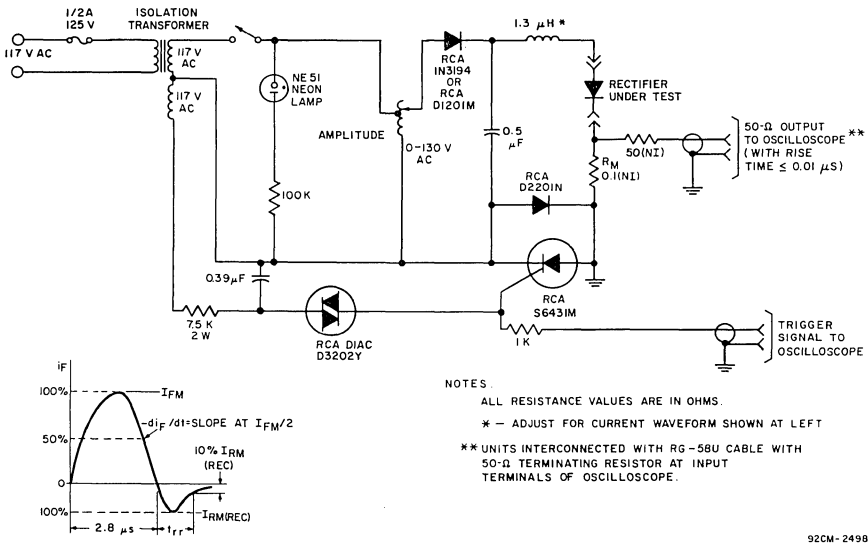

Fig. 8 — Oscilloscope display and test circuit for measurement of reverse-recovery time for D2600M, D2601E, and D2601M.

**TERMINAL CONNECTIONS
FOR TYPES
S3705M AND S3706E**

- Pin 1 — Gate
- Pin 2 — Cathode
- Case, Mounting Flange — Anode

**TERMINAL CONNECTIONS
FOR TYPES
D2600M, D2601E, AND D2601M**

- Case, Lead 1 — Cathode
- Lead 2 — Anode

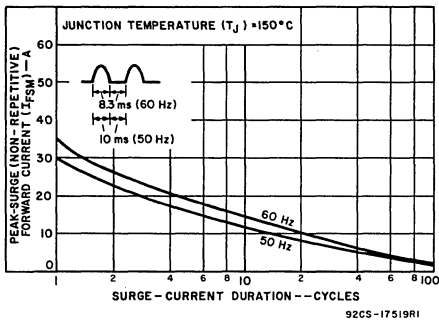

Fig. 9 - Peak-surge (non-repetitive) forward current vs. surge-current duration for D2600M, D2601E, and D2601M.

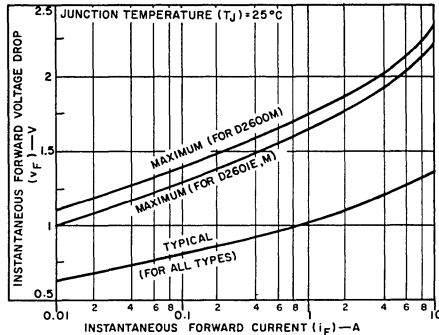

Fig. 10 - Forward-voltage drop vs. forward current for D2600M, D2601E, and D2601M.

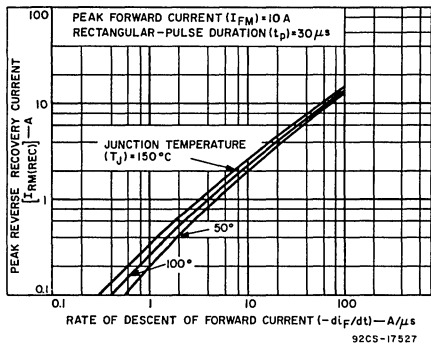

Fig. 11 - Typical peak reverse-recovery current vs. rate of descent of forward current for D2600M, D2601E, and D2601M.

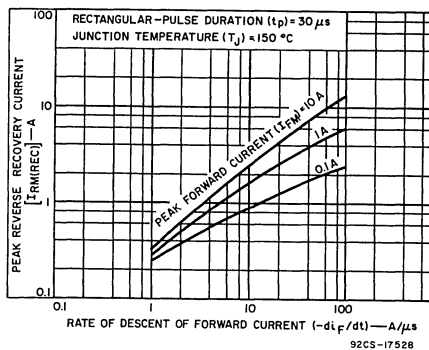

Fig. 12 - Typical peak reverse-recovery current vs. rate of descent of forward-current for D2600M, D2601E, and D2601M.

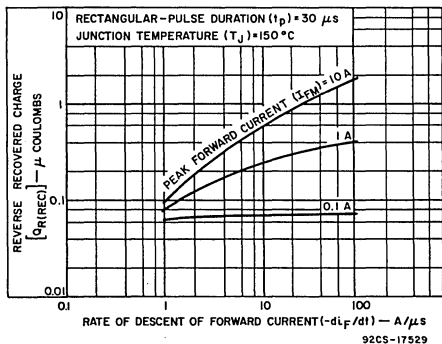

Fig. 13 - Typical reverse-recovered charge vs. rate of descent of forward current for D2600M, D2601E, and D2601M.

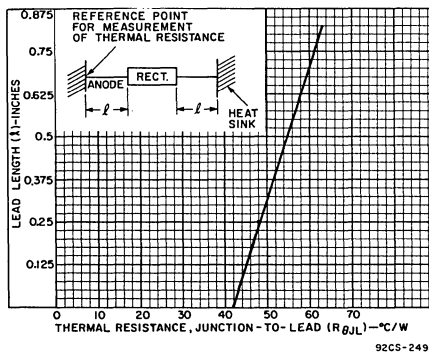

Fig. 14 - Junction-to-lead thermal resistance vs. lead length for D2600M, D2601E, and D2601M.