

用途：用于一般功率输出放大。

Purpose: Power out amplifier applications.

特点：击穿电压高, 饱和压降低。

Features: High V_{CE0} , low $V_{CE(sat)}$.

极限参数/Absolute maximum ratings ($T_a=25^\circ\text{C}$)

参数符号 Symbol	数值 Rating	单位 Unit
V_{CBO}	100	V
V_{CEO}	100	V
V_{EBO}	5.0	V
I_C	5.0	A
P_C	2.0	W
$P_C(T_c=25^\circ\text{C})$	40	W
T_j	150	$^\circ\text{C}$
T_{stg}	-55~150	$^\circ\text{C}$

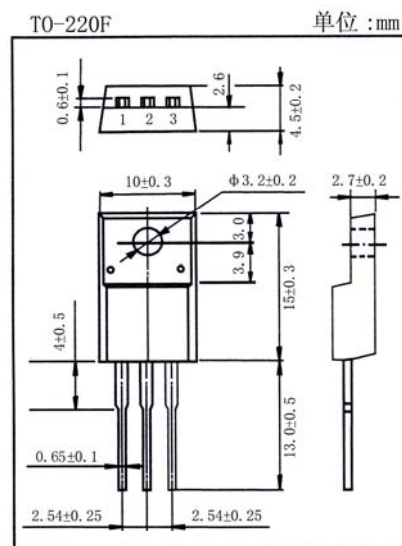

引脚： 1. B 2. C 3. E

电性能参数/Electrical characteristics ($T_a=25^\circ\text{C}$)

参数符号 Symbol	测试条件 Test condition		数值 Rating			单位 Unit
			最小值 Min	典型值 Typ	最大值 Max	
I_{CBO}	$V_{CB}=100\text{V}$	$I_E=0$			20	μA
I_{EBO}	$V_{EB}=5.0\text{V}$	$I_C=0$			20	μA
h_{FE}	$V_{CE}=5.0\text{V}$	$I_C=1.0\text{A}^*$	60		200	
$V_{CE(sat)}$	$I_C=3.0\text{A}$	$I_B=0.3\text{A}^*$			1.0	V
f_T	$V_{CE}=5.0\text{V}$	$I_C=500\text{mA}$	10			MHz

*: 脉冲测试/pulse test.

h_{FE} 分档/ h_{FE} classifications: R: 60~120 0: 100~200

