

# SHINDENGEN

## Super Fast Recovery Rectifiers

Single

# D2FL40

**400V 1.3A**

### FEATURES

- Small SMT
- Low noise
- trr50ns

### APPLICATION

- Switching power supply
- DC/DC converter
- Free Wheel
- Home Appliances, Office Equipment
- Telecommunication, Factory Automation

### OUTLINE DIMENSIONS

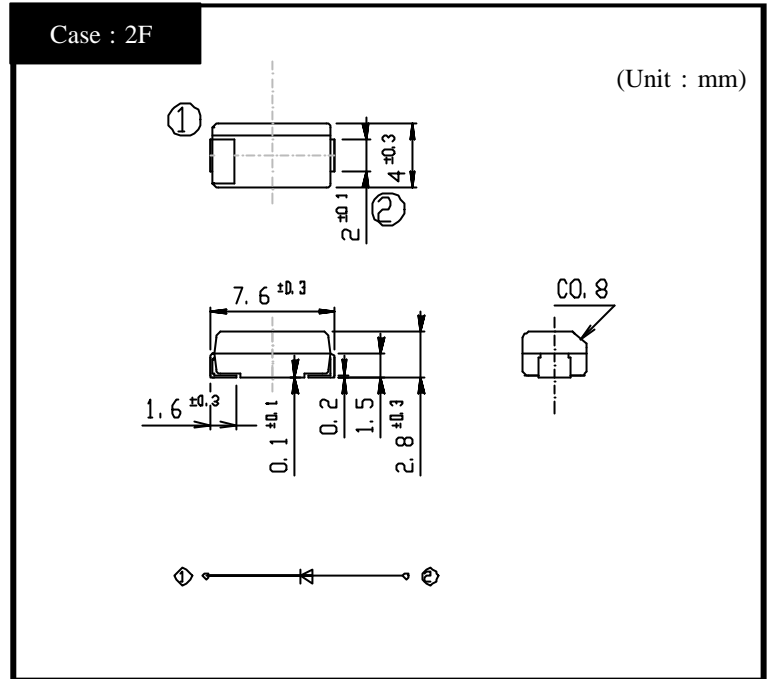

### RATINGS

Absolute Maximum Ratings (If not specified Tl=25 )

Item	Symbol	Conditions	Ratings	Unit
Storage Temperature	Tstg		-40 ~ 150	
Operating Junction Temperature	Tj		150	
Maximum Reverse Voltage	V <sub>RM</sub>		400	V
Average Rectified Forward Current	I <sub>O</sub>	50Hz sine wave, R-load, Ta=25 On alumina substrate	1.3	A
		50Hz sine wave, R-load, Ta=25 On glass-epoxy substrate	1.05	
Peak Surge Forward Current	I <sub>FSM</sub>	50Hz sine wave, Non-repetitive 1 cycle peak value, Tj=25	40	A

Electrical Characteristics (If not specified Tl=25 )

Item	Symbol	Conditions	Ratings	Unit
Forward Voltage	V <sub>F</sub>	I <sub>F</sub> =1.3A, Pulse measurement	Max.1.3	V
Reverse Current	I <sub>R</sub>	V <sub>R</sub> =V <sub>RM</sub> , Pulse measurement	Max.10	μA
Reverse Recovery Time	t <sub>rr</sub>	I <sub>F</sub> =0.5A, I <sub>R</sub> =1A	Max.50	ns
Thermal Resistance	j	junction to lead	Max.24	/W
		junction to ambient, On alumina substrate	Max.90	
		junction to ambient, On glass-epoxy substrate	Max.120	

# D2FL40

# Forward Voltage

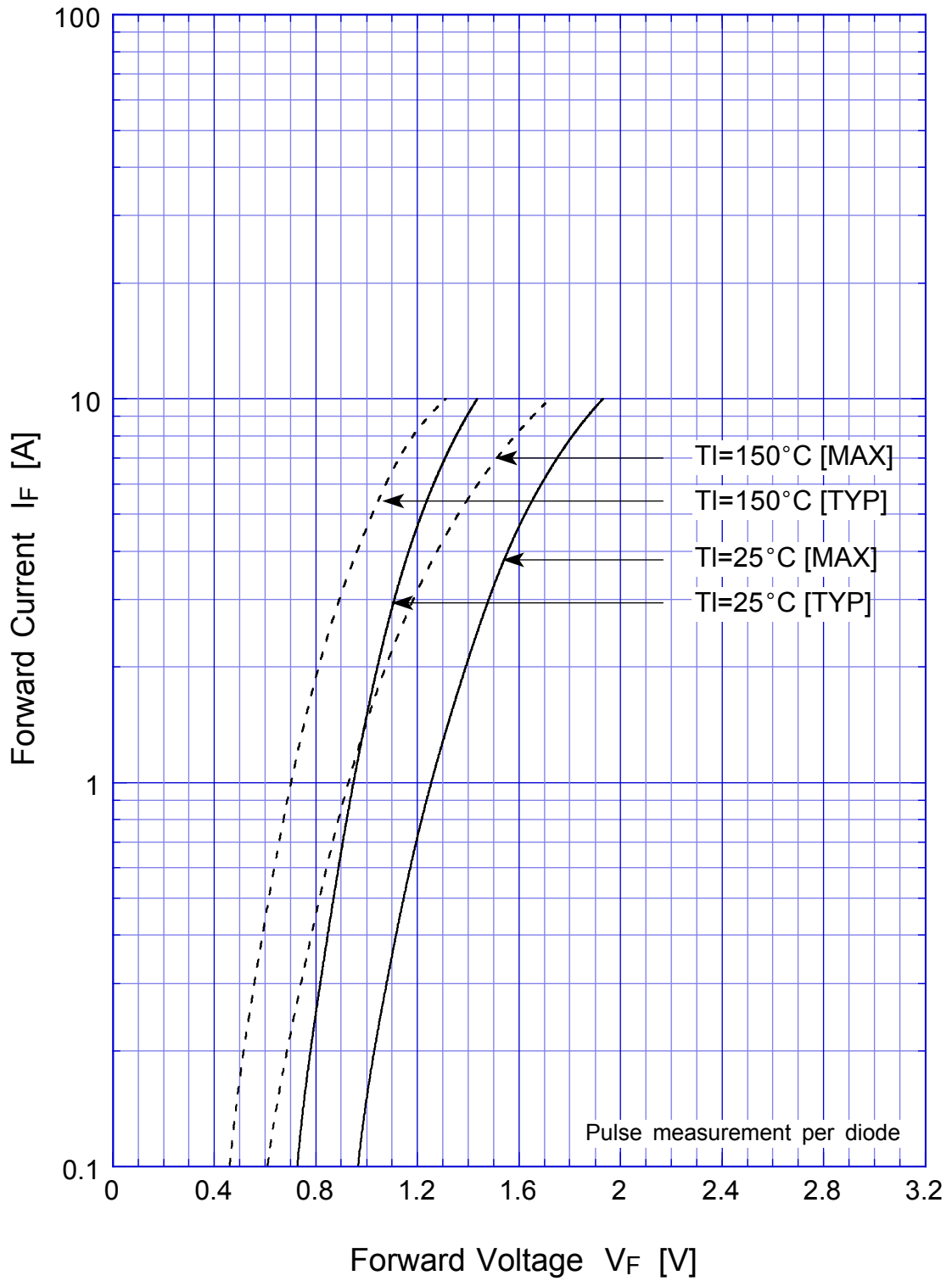

# D2FL40

## Forward Power Dissipation

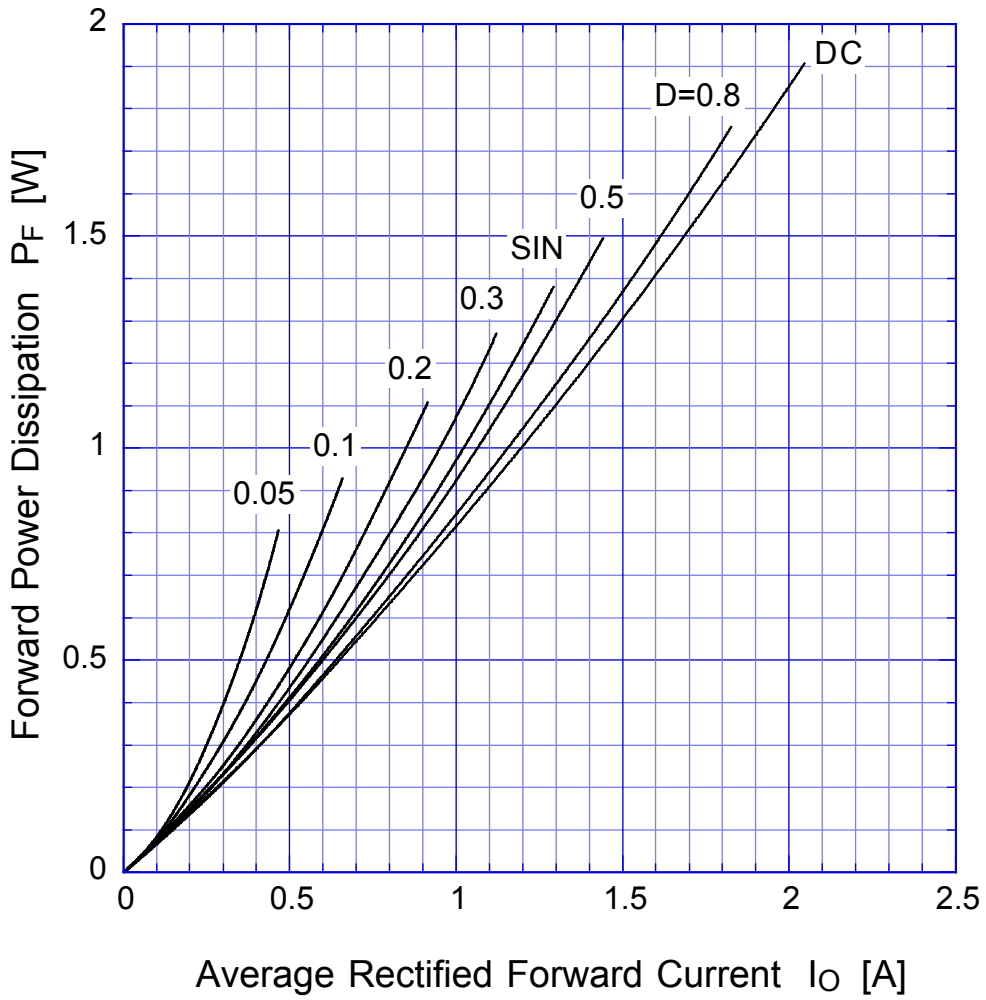

$T_j = T_{jmax}$

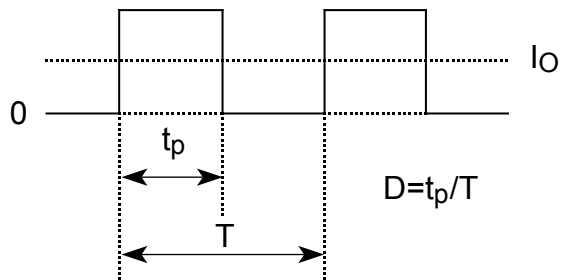

# D2FL40

# Derating Curve

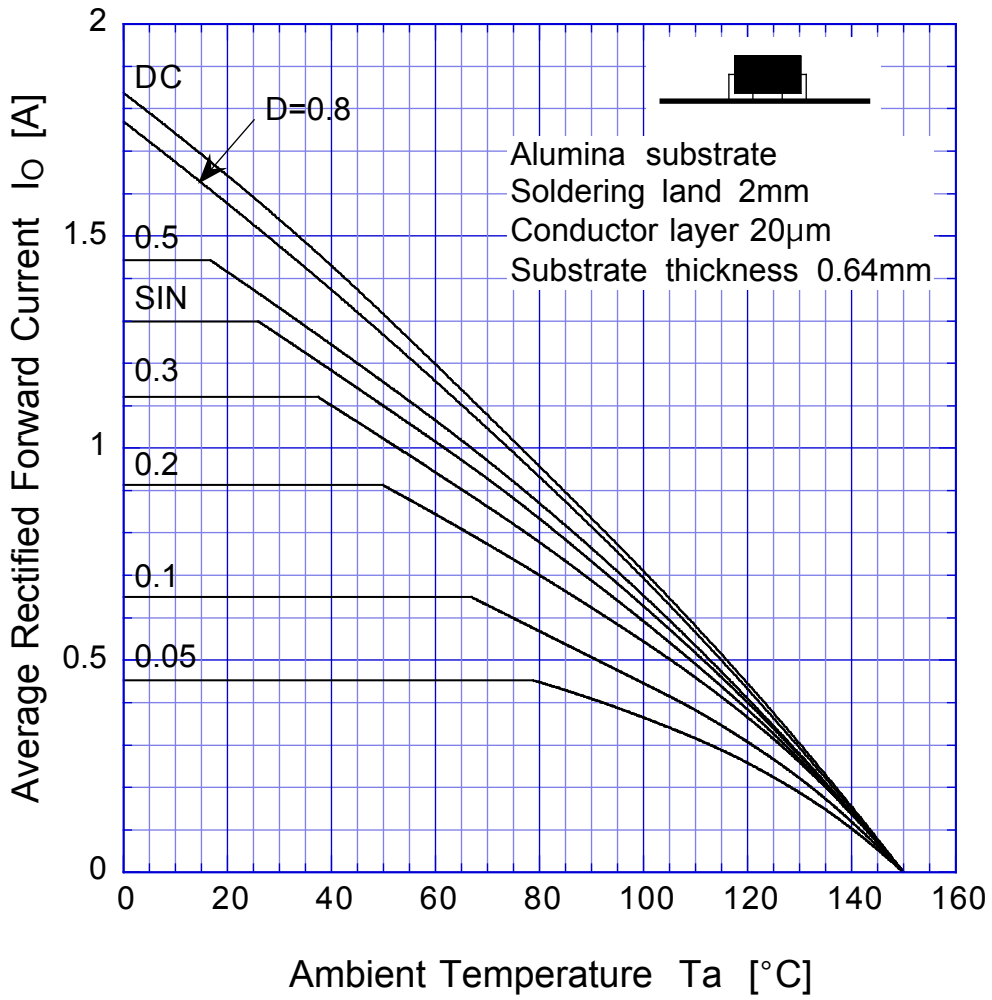

$$V_R = V_{RM}$$



# D2FL40

# Derating Curve

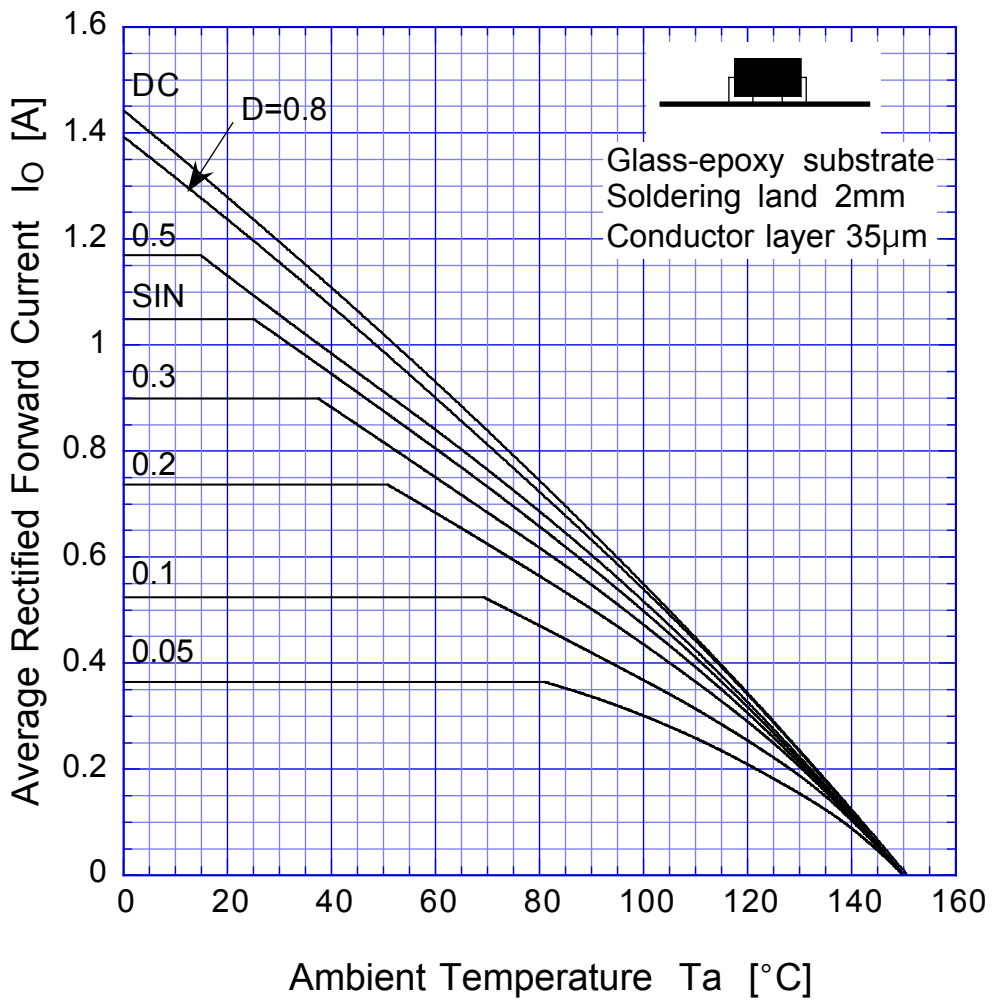

$$V_R = V_{RM}$$

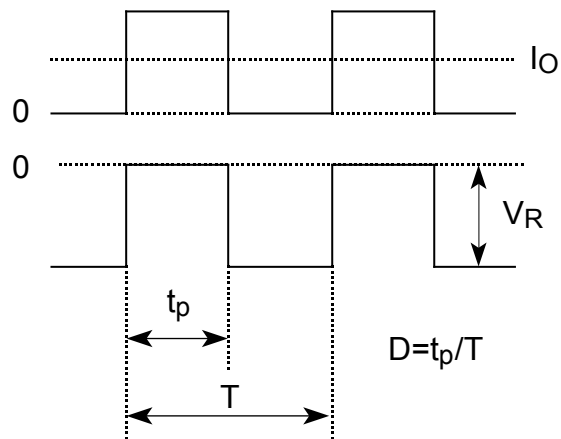

# D2FL40

## Peak Surge Forward Capability

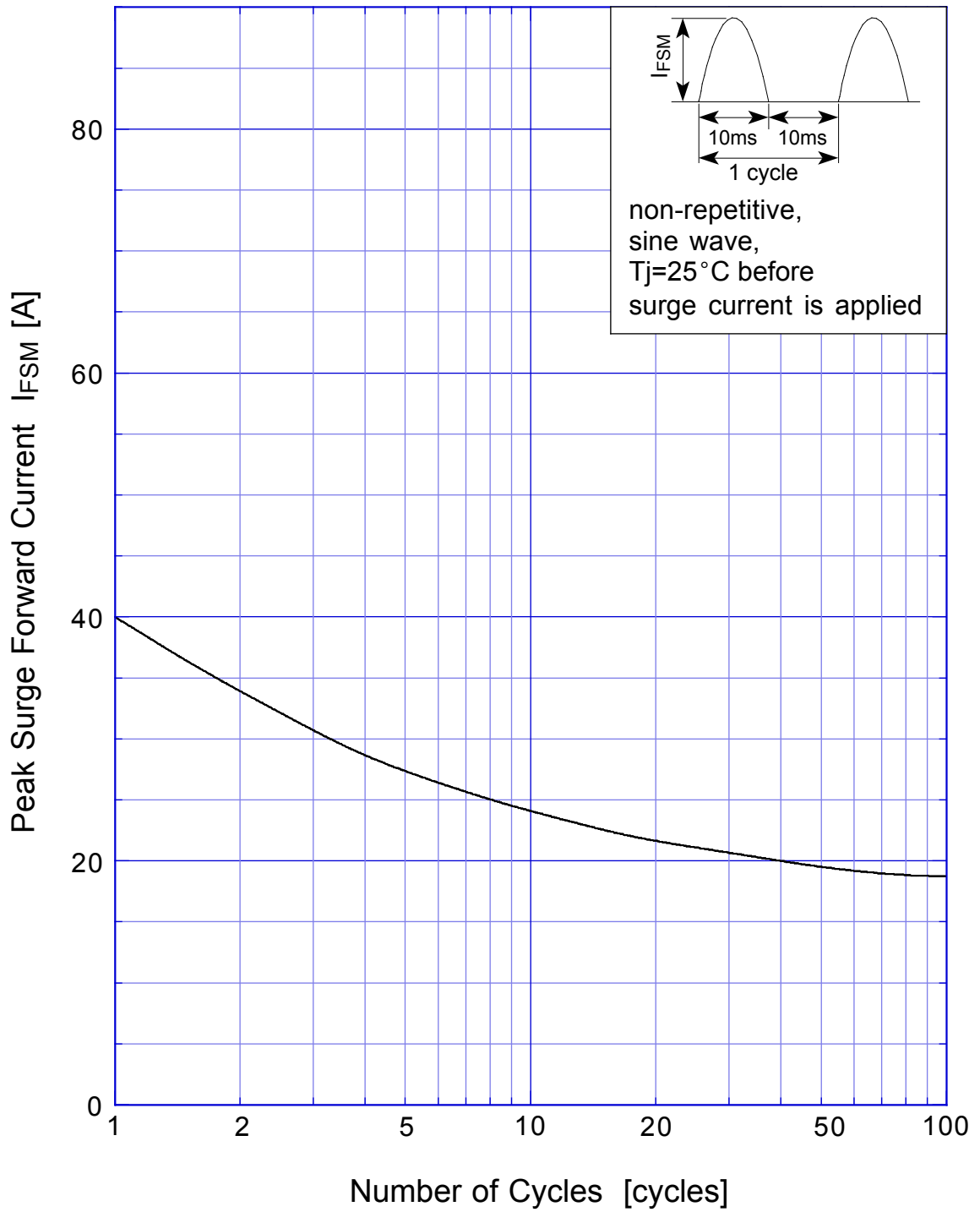

# D2FL40 Junction Capacitance

