

N

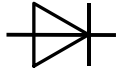

## Datenblatt / Data sheet

power electronics in motion

eupec

Netz-Gleichrichterdiode  
Rectifier Diode

D 3041N

Zieldaten

Elektrische Eigenschaften / Electrical properties  
Höchstzulässige Werte / Maximum rated values

Periodische Rückwärts-Spitzensperrspannung repetitive peak reverse voltages	$T_{vj} = -40^{\circ}\text{C} \dots T_{vj \max}$	$V_{RRM}$	5800 6500	6000 6800	V V
Periodische Rückwärts-Spitzensperrspannung repetitive peak reverse voltages	$T_{vj} = 0^{\circ}\text{C} \dots T_{vj \max}$	$V_{RRM}$	6000 6700	6200 7000	V V
Durchlaßstrom-Grenzeffektivwert maximum RMS on-state current		$I_{FRMSM}$		6440	A
Dauergrenzstrom average on-state current	$T_C = 100^{\circ}\text{C}$ $T_C = 60^{\circ}\text{C}$	$I_{FAVM}$		3030 4100	A A
Stoßstrom-Grenzwert surge current	$T_{vj} = 25^{\circ}\text{C}, t_p = 10 \text{ ms}$ $T_{vj} = T_{vj \max}, t_p = 10 \text{ ms}$	$I_{FSM}$		57000 53000	A A
Grenzlastintegral $I^2t$ -value	$T_{vj} = 25^{\circ}\text{C}, t_p = 10 \text{ ms}$ $T_{vj} = T_{vj \max}, t_p = 10 \text{ ms}$	$I^2t$		16240 14040	$10^3 \text{ A}^2\text{s}$ $10^3 \text{ A}^2\text{s}$
Spitzensperrverlustleistung Surge reverse power dissipation	$T_{vj} = 25^{\circ}\text{C}, t_p = 20 \mu\text{s}$ $T_{vj} = T_{vj \max}, t_p = 20 \mu\text{s}$	$P_{RSM}$			$10^3 \text{ W}$ $10^3 \text{ W}$

## Charakteristische Werte / Characteristic values

Durchlaßspannung on-state voltage	$T_{vj} = T_{vj \max}, i_F = 4000 \text{ A}$	$V_F$	typ. max.	1,58 1,7	V V
Schleusenspannung threshold voltage	$T_{vj} = T_{vj \max}$	$V_{(TO)}$	typ. max.	0,78 0,84	V V
Ersatzwiderstand slope resistance	$T_{vj} = T_{vj \max}$	$r_T$	typ. max.	0,20 0,22	mΩ mΩ
Durchlaßkennlinie on-state characteristic  $v_F = A + B \cdot i_T + C \cdot \ln(i_T + 1) + D \cdot \sqrt{i_T}$	$1500\text{A} \leq i_F \leq 4000\text{A}$  $T_{vj} = T_{vj \max}$	typ.  max.	A B C D  A B C D	0,4075395 0,00008787 0,0173038 0,010806  0,442073 9,7148E-5 0,0187525 0,0113256	
Rückwärts-Sperrstrom reverse current	$T_{vj} = T_{vj \max}, V_R = V_{RRM}$	$i_R$	max.	100	mA

[www.DataSheet.in](http://www.DataSheet.in)

prepared by:	C. Schneider	date of publication:	2003-10-24
approved by:	R. Keller	revision:	0

Netz-Gleichrichterdiode  
Rectifier Diode

## D 3041N

## Zieldaten

**Elektrische Eigenschaften / Electrical properties**  
Charakteristische Werte / Characteristic values

Sperrverzögerungsladung recovered charge	$V_R = 1000V, T_{vj} = T_{vj\ max}$ $C = 1\mu F, R = 22\Omega$ $i_{TM} = 1000A, -di_T/dt = 10 A/\mu s$	$Q_r$	max.	11	mAs
Rückstromspitze peak reverse recovery current	$V_R = 1000V, T_{vj} = T_{vj\ max}$ $C = 1\mu F, R = 22\Omega$ $i_{TM} = 1000A, -di_T/dt = 10 A/\mu s$	$I_{RM}$	max.	300	A

Sperrverzögerungsladung recovered charge	$V_R = 100V, T_{vj} = T_{vj\ max}$ $C = 1\mu F, R = 22\Omega$ $i_{TM} = 1000A, -di_T/dt = 10 A/\mu s$	$Q_r$	typ.	9	mAs
Rückstromspitze peak reverse recovery current	$V_R = 100V, T_{vj} = T_{vj\ max}$ $C = 1\mu F, R = 22\Omega$ $i_{TM} = 1000A, -di_T/dt = 10 A/\mu s$	$I_{RM}$	typ.	240	A

**Thermische Eigenschaften / Thermal properties**

Innerer Wärmewiderstand thermal resistance, junction to case	<u>Kühlfläche / cooling surface</u> beidseitig / two-sided, $\theta = 180^\circ$ sin beidseitig / two-sided, DC Anode / anode, DC Kathode / cathode, DC	$R_{thJC}$	max.	0,00827	$^\circ C/W$
			max.	0,0075	$^\circ C/W$
			max.	0,0133	$^\circ C/W$
			max.	0,0172	$^\circ C/W$
Übergangs-Wärmewiderstand thermal resistance, case to heatsink	<u>Kühlfläche / cooling surface</u> beidseitig / two-sided einseitig / single-sided	$R_{thCH}$	max.	0,0025	$^\circ C/W$
			max.	0,005	$^\circ C/W$
Höchstzulässige Sperrschichttemperatur maximum junction temperature		$T_{vj\ max}$		160	$^\circ C$
Betriebstemperatur operating temperature		$T_{c\ op}$		-40...+160	$^\circ C$
Lagertemperatur storage temperature		$T_{stg}$		-40...+160	$^\circ C$

**Mechanische Eigenschaften / Mechanical properties**

Gehäuse, siehe Anlage case, see annex				Seite 3 page 3	
Si-Element mit Druckkontakt Si-pellet with pressure contact				76DNE68	
Anpresskraft clamping force		F		36...53	kN
Gewicht weight		G	typ.	1200	g
Kriechstrecke creepage distance				33	mm
Schwingfestigkeit vibration resistance	f = 50 Hz			50	m/s <sup>2</sup>

[www.DataSheet.in](http://www.DataSheet.in)

Mit diesem Datenblatt werden Halbleiterbauelemente spezifiziert, jedoch keine Eigenschaften zugesichert. Sie gilt in Verbindung mit den zugehörigen technischen Erläuterungen.

This data sheet specifies semiconductor devices, but promises no characteristics. It is valid in combination with the belonging technical notes.

D120/26

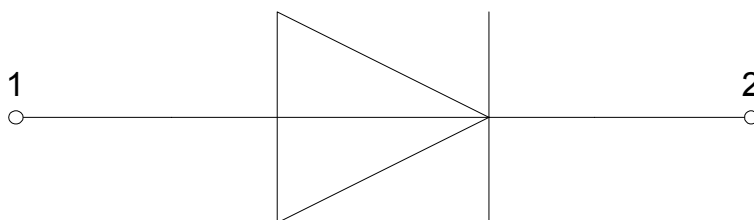
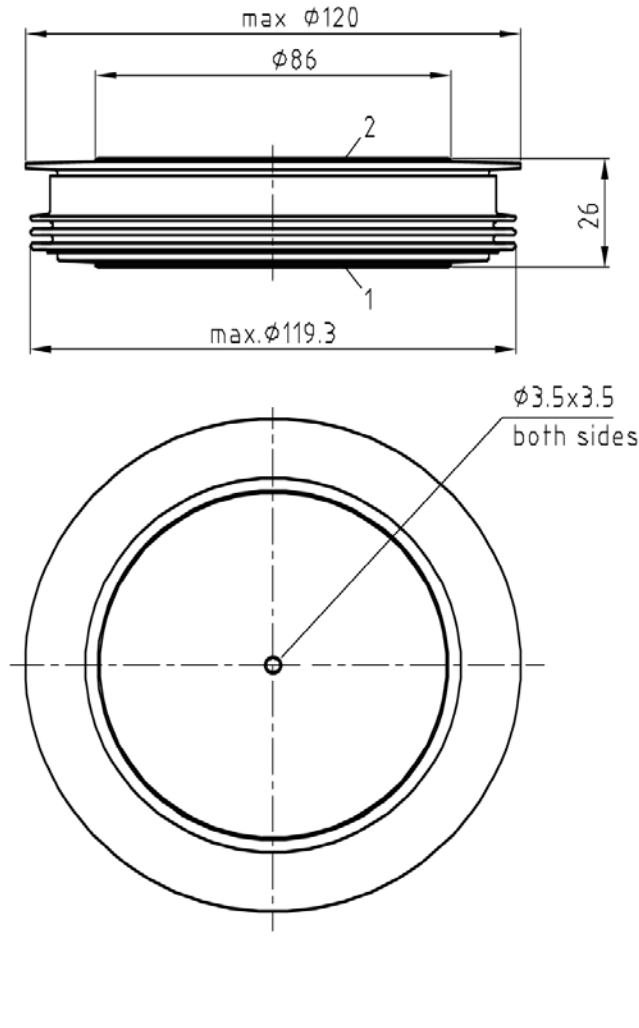

**1: Anode/Anode**

**2: Kathode/Cathode**

Analytische Elemente des transienten Wärmewiderstandes  $Z_{thJC}$   
Analytical elements of transient thermal impedance  $Z_{thJC}$

	Pos. n	1	2	3	4	5	6	7
beidseitig two-sided	$R_{thn}$ [ $^{\circ}C/W$ ]	0,00295	0,002	0,00154	0,00098	0,00003		
	$\tau_n$ [s]	0,78008	0,13092	0,02165	0,00514	0,00104		
anodenseitig anode-sided	$R_{thn}$ [ $^{\circ}C/W$ ]	0,00804	0,00081	0,00239	0,0016	0,00046		
	$\tau_n$ [s]	5,11029	0,35916	0,09623	0,01197	0,00332		
kathodenseitig cathode-sided	$R_{thn}$ [ $^{\circ}C/W$ ]	0,0121	0,0004	0,00244	0,00155	0,00071		
	$\tau_n$ [s]	4,97289	0,48885	0,12071	0,01530	0,00427		

Analytische Funktion / Analytical function:

$$Z_{thJC} = \sum_{n=1}^{n_{max}} R_{thn} \left( 1 - e^{-\frac{t}{\tau_n}} \right)$$

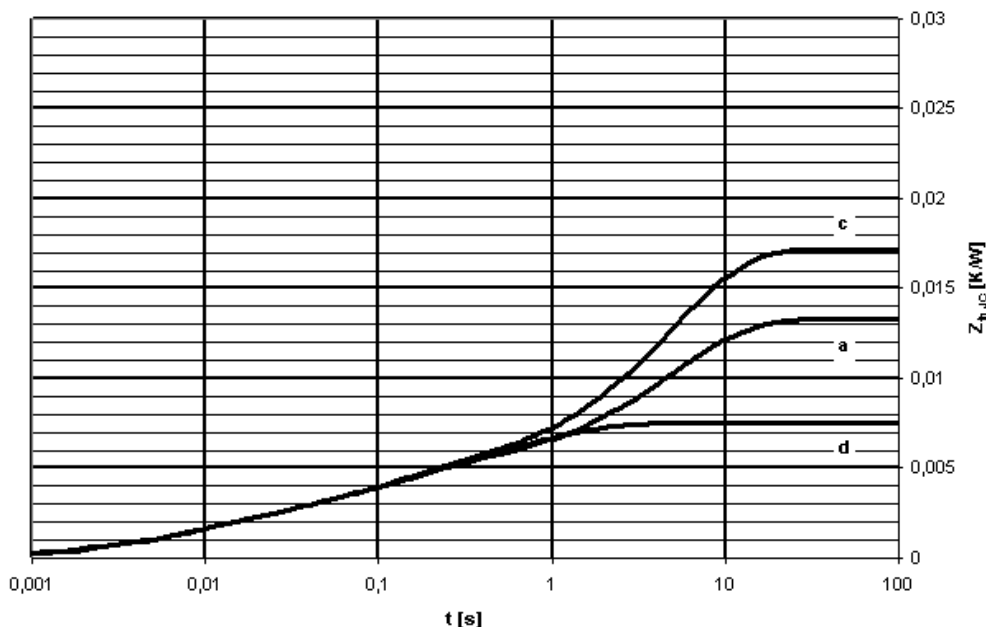

Transienter innerer Wärmewiderstand für DC/ Transient thermal impedance  $Z_{thJC} = f(t)$  for DC

Beidseitige Kühlung / Two-sided cooling

Anodenseitige Kühlung / Anode-sided cooling

Kathodenseitige Kühlung / Cathode-sided cooling

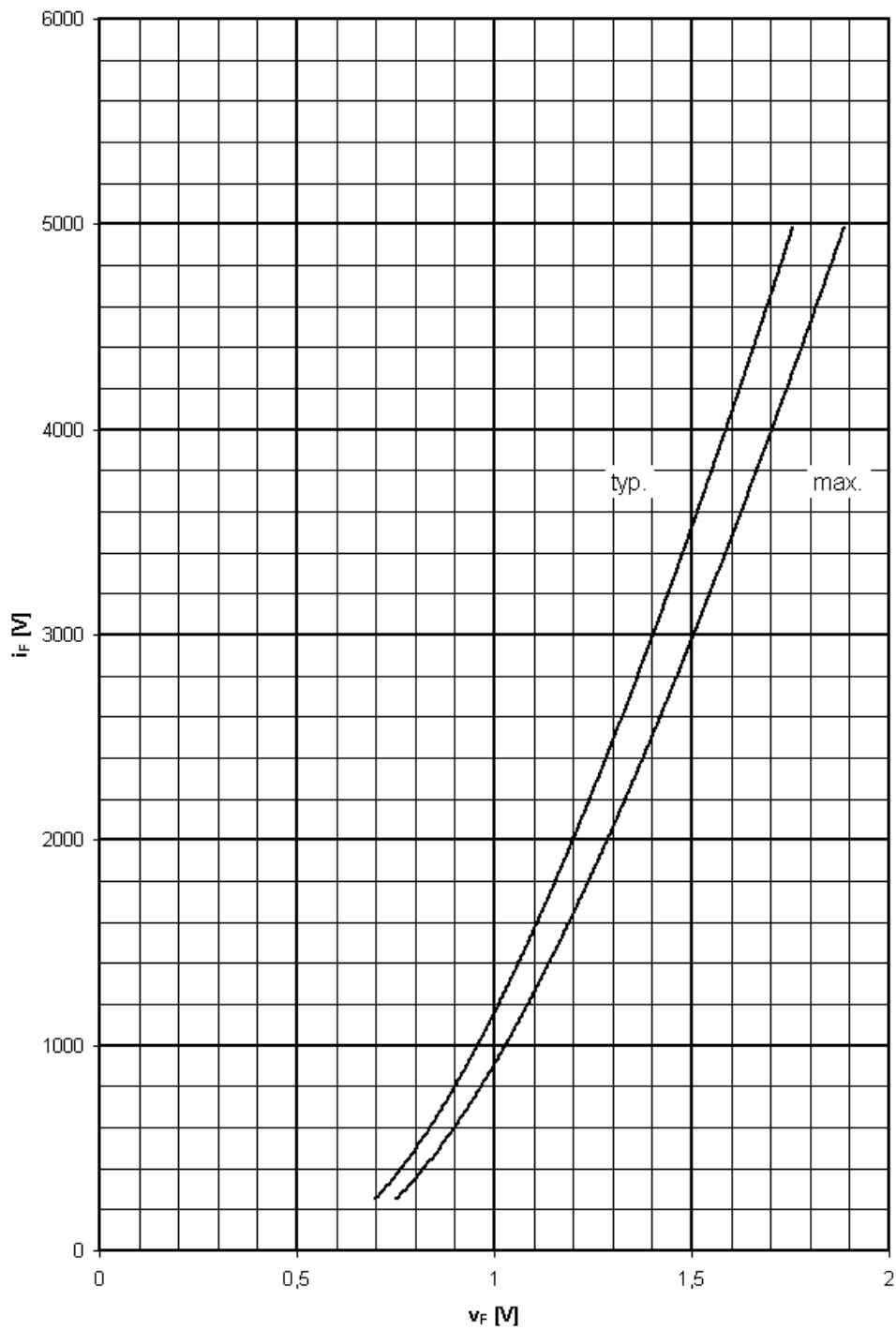

Grenzdurchlaßkennlinie / Limiting on-state characteristic  $i_F = f(v_F)$

$$T_{vj} = T_{vj \max}$$

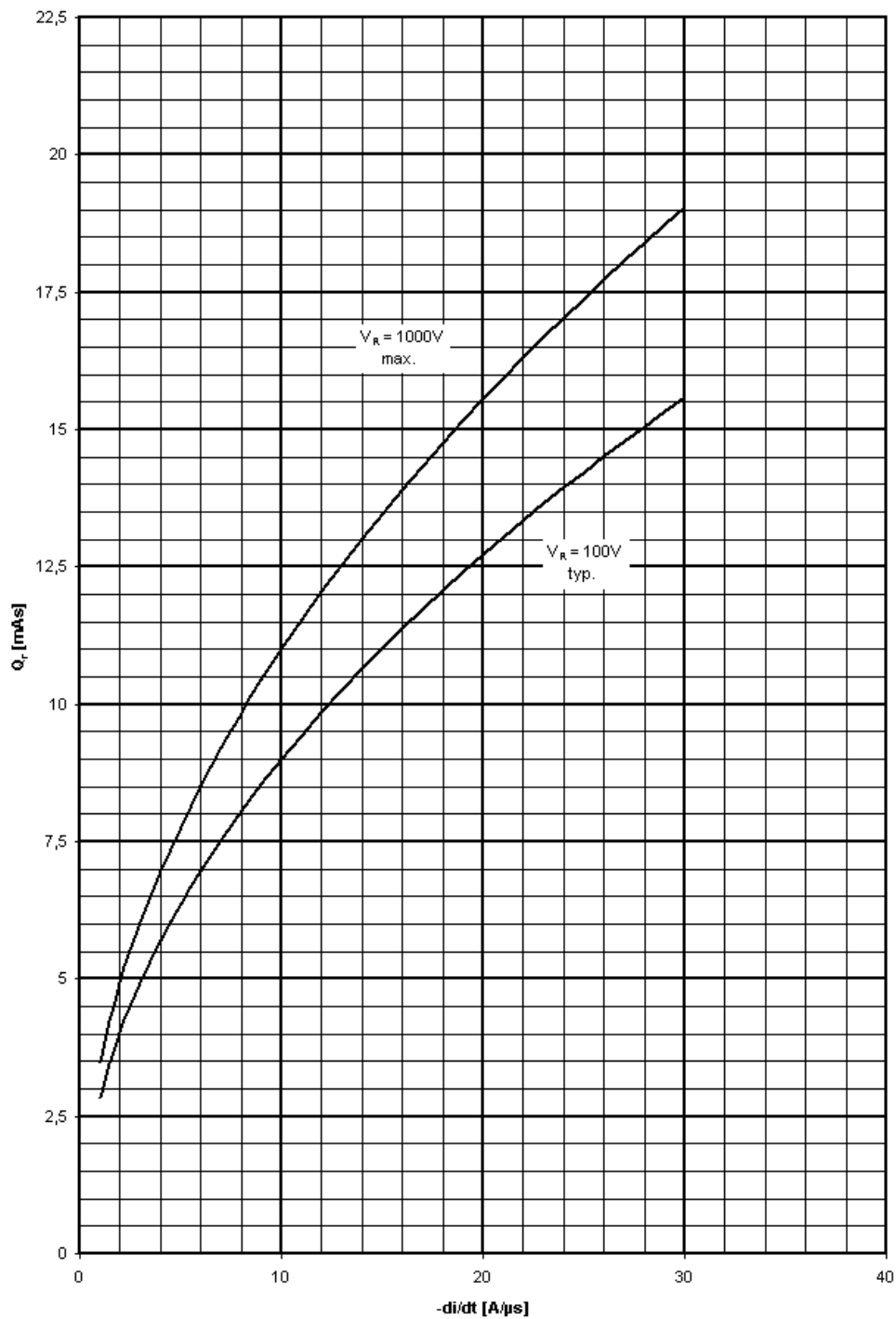

Sperrverzögerungsladung / Recovered charge  $Q_r = f(-di/dt)$

$$T_{vj} = T_{vjmax}, C = 1\mu F, R = 22\Omega$$

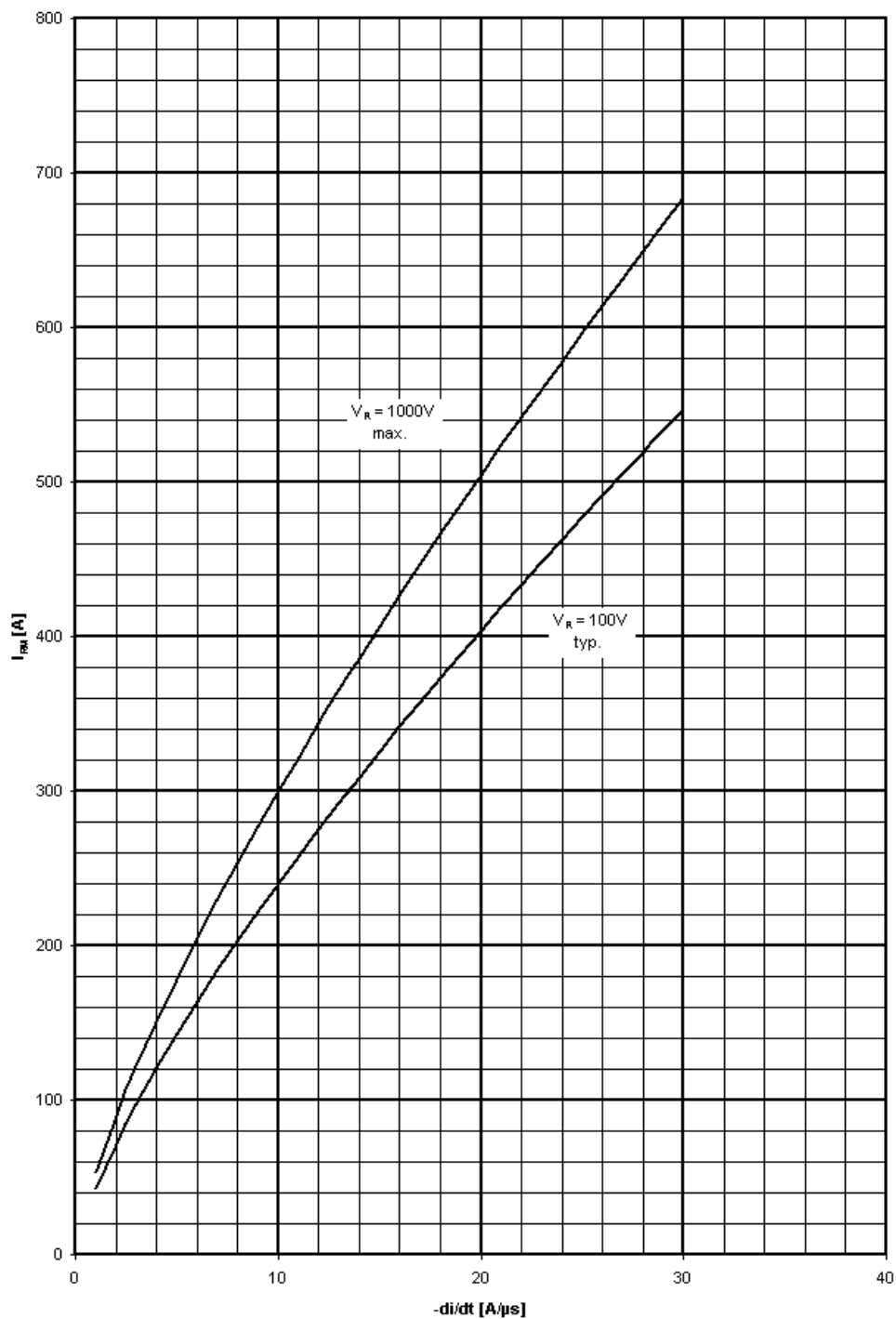

Rückstromspitze / Peak reverse recovery current  $I_{RM} = f(-di/dt)$

$T_{vj} = T_{vjmax}$ ,  $C = 1\mu F$ ,  $R = 22\Omega$

## **Terms & Conditions of Usage**

### **Attention**

The present product data is exclusively subscribed to technically experienced staff. This Data Sheet is describing the specification of the products for which a warranty is granted exclusively pursuant the terms and conditions of the supply agreement. There will be no guarantee of any kind for the product and its specifications. Changes to the Data Sheet are reserved.

You and your technical departments will have to evaluate the suitability of the product for the intended application and the completeness of the product data with respect to such application. Should you require product information in excess of the data given in the Data Sheet, please contact your local Sales Office via "[www.eupec.com / sales & contact](http://www.eupec.com / sales & contact)".

### **Warning**

Due to technical requirements the products may contain dangerous substances. For information on the types in question please contact your local Sales Office via "[www.eupec.com / sales & contact](http://www.eupec.com / sales & contact)".