

Glass Passivated Bridge Rectifiers

 Lead(Pb)-Free

REVERSE VOLTAGE
50 TO 1000 VOLTS
FORWARD CURRENT
4.0 AMPERE

Features:

- * Glass passivated chip junction
- * High case dielectric strength
- * High surge current capability
- * Ideal for printed circuit board

Mechanical Data:

- * Terminal:Plated leads solderable per MIL-STD 202E, Method 208C
- * Case:UL-94 Class V-0 recognized Flame Retardant Epoxy
- * Polarity:Polarity symbol marked on body
- * Mounting position:any

D3K Outline Dimensions

Unit:mm

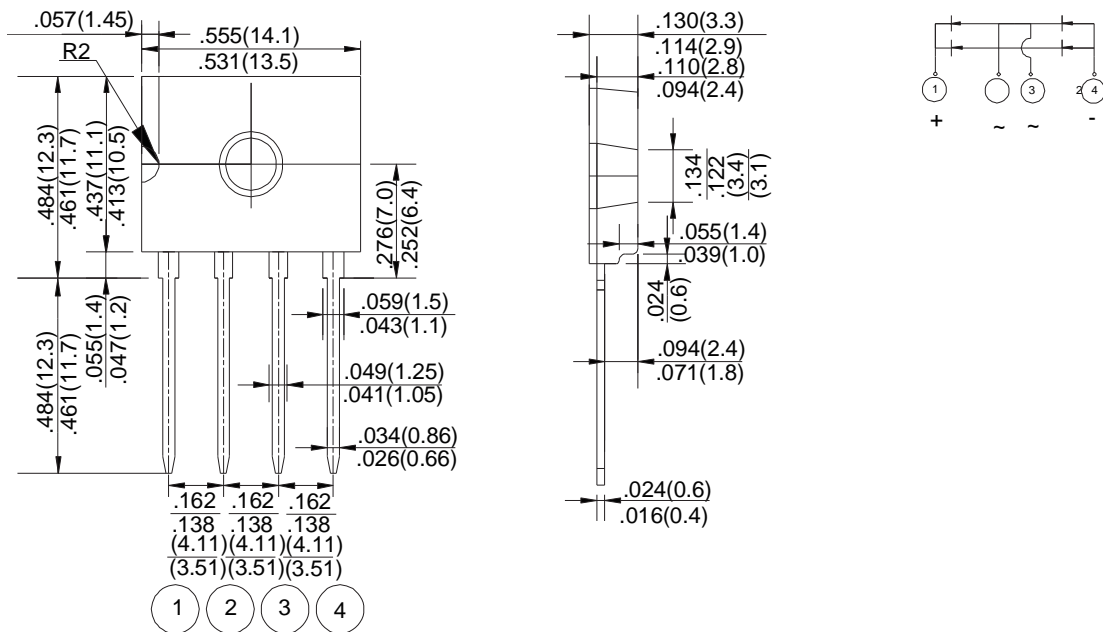

MAXIMUM RATINGS AND ELECTRICAL CHARACTERISTICS

Rating at 25°C ambient temperature unless otherwise specified.

Single phase, half wave ,60Hz, resistive or inductive load.

For capacitive load, derate current by 20%

CHARACTERISTICS	SYMBOL	D4KB05	D4KB1	D4KB2	D4KB4	D4KB6	D4KB8	D4KB10	UNIT
Maximum Recurrent Peak Reverse Voltage	V _{RRM}	50	100	200	400	600	800	1000	V
Maximum RMS Voltage	V _{RMS}	35	70	140	280	420	560	700	V
Maximum DC Blocking Voltage	V _{DC}	50	100	200	400	600	800	1000	V
Maximum Average Forward Rectified Current @T _A =138°C (with heatsink)	I _(AV)	4							A
Peak Forward Surge Current 8.3ms Single Half Sine-Wave Super Imposed on Rated Load (JEDEC Method)	I _{FSM}	125							A
Maximum Forward Voltage at 4.0A DC	V _F	1.1							V
I ² t Rating for Fusing (t<8.3ms)	I ² t	64.84							A ² s
Maximum DC Reverse Current at Rated DC Blocking Voltage	I _R	10.0 500							uA
Typical Thermal Resistance	R _{θJA} R _{θJC} R _{θJL}	55 1.5 15							°C/W
Operating Temperature Range	T _J	-55 to +150							°C
Storage Temperature Range	T _{STG}	-55 to +150							°C

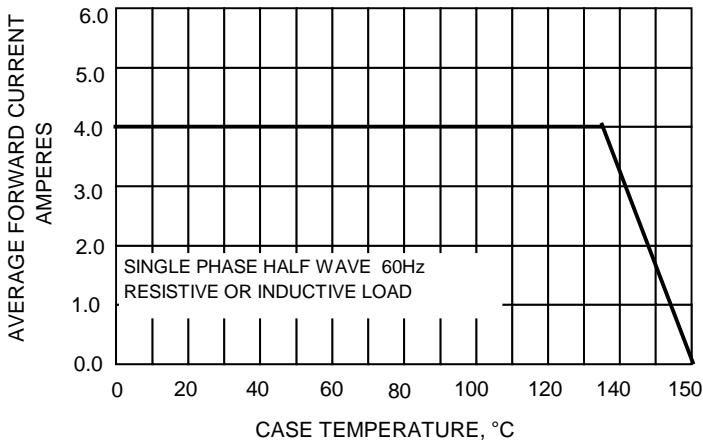

FIG.1-DERATING CURVE OUTPUT RECTIFIED CURRENT

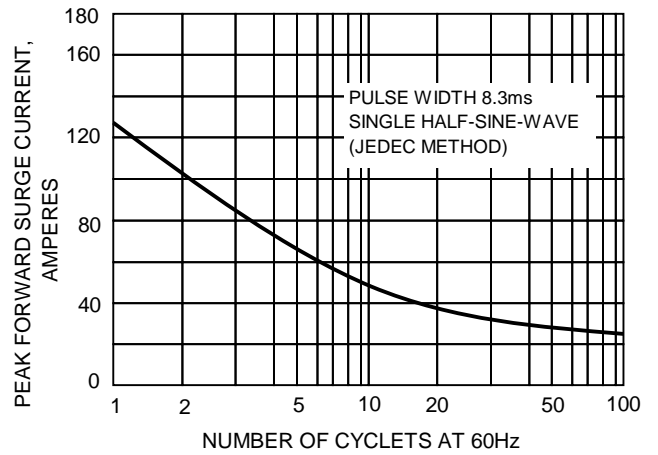

FIG.2-MAXIMUM NON-REPETITIVE SURGE CURRENT

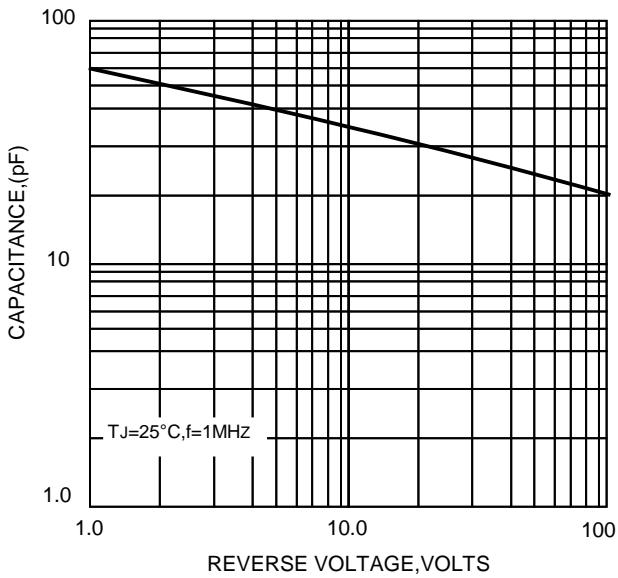

FIG.3-TYPICAL JUNCTION CAPACITANCE

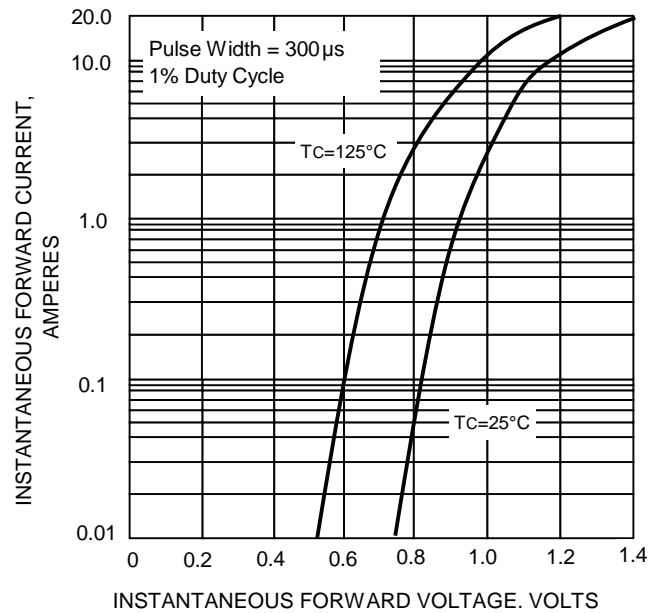

FIG.3-TYPICAL FORWARD CHARACTERISTICS

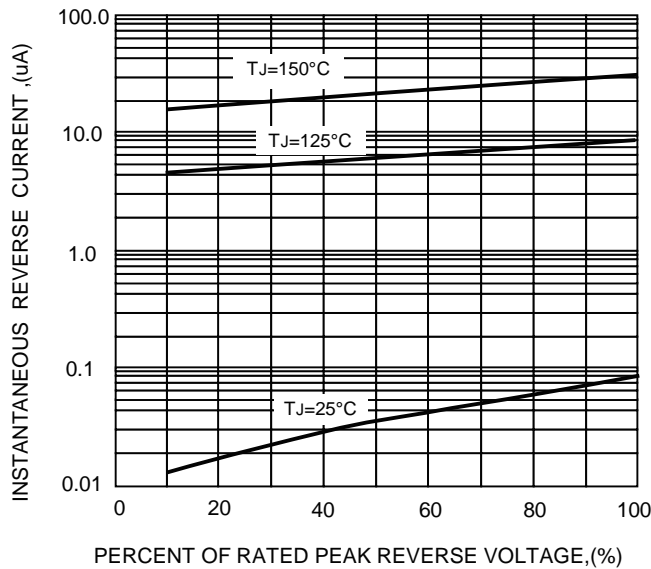

FIG.5-TYPICAL REVERSE CHARACTERISTICS