

SHINDENGEN

General Purpose Rectifiers

SIL Bridges

D4KB80R

800V 4A

APPLICATION

- Monitor
- TV
- Audio equipment
- Printer
- SMPS
- Adapter for notebook PC
- Power supply for desktop PC

OUTLINE DIMENSIONS

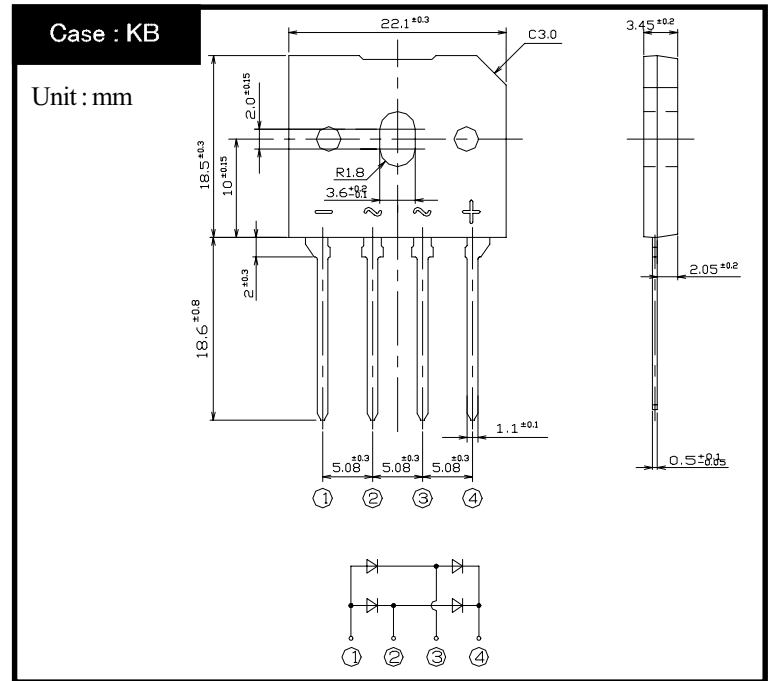

RATINGS

● Absolute Maximum Ratings (If not specified, Tc=25°C)

Item	Symbol	Conditions	Ratings	Unit
Storage Temperature	T _{stg}		-55 ~ 150	°C
Operating Junction Temperature	T _j		150	°C
Maximum Reverse Voltage	V _{RM}		800	V
Average Rectified Forward Current	I _O	50Hz sine wave, R-load, On glass-epoxy substrate Ta=25°C	3.15	A
		50Hz sine wave, R-load Tc=111°C	4.0	
Peak Surge Forward Current	I _{FSM}	60Hz sine wave, Non-repetitive 1 cycle peak value, T _j =25°C	150	A
Current Squared Time	I ² t	1ms ≤ t < 10ms T _j =25°C, Rating of per diode	50	A ² s
Dielectric Strength	V _{dis}	Terminals to case, AC 1 minute	2.0	kV
Mounting Torque	TOR	(Recommended torque: 0.5N·m)	0.8	N·m

● Electrical Characteristics (If not specified, Tc=25°C)

Item	Symbol	Conditions	Ratings	Unit
Forward Voltage	V _F	I _F =4A, Pulse measurement, Rating of per diode	Max 1.0	V
Reverse Current	I _R	V _R =800V, Pulse measurement, Rating of per diode	Max 10	μA
Thermal Resistance	θ _{jl}	junction to lead, On glass-epoxy substrate	Max 4.2	°C/W
	θ _{ja}	junction to ambient, On glass-epoxy substrate	Max 23	
	θ _{jc}	junction to case	Max 5.5	

D4KB80R Forward Voltage

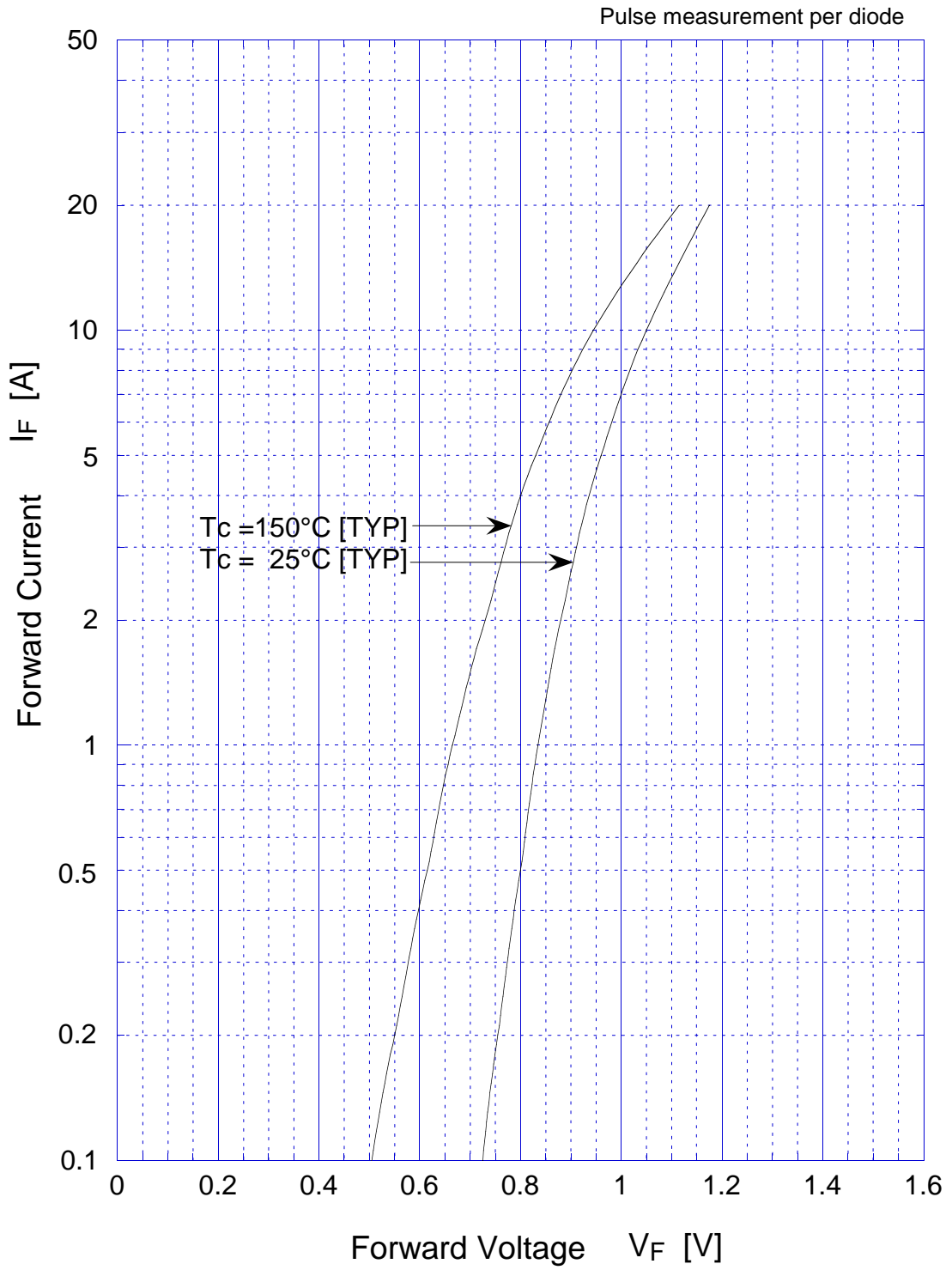

D4KB80R Forward Power Dissipation

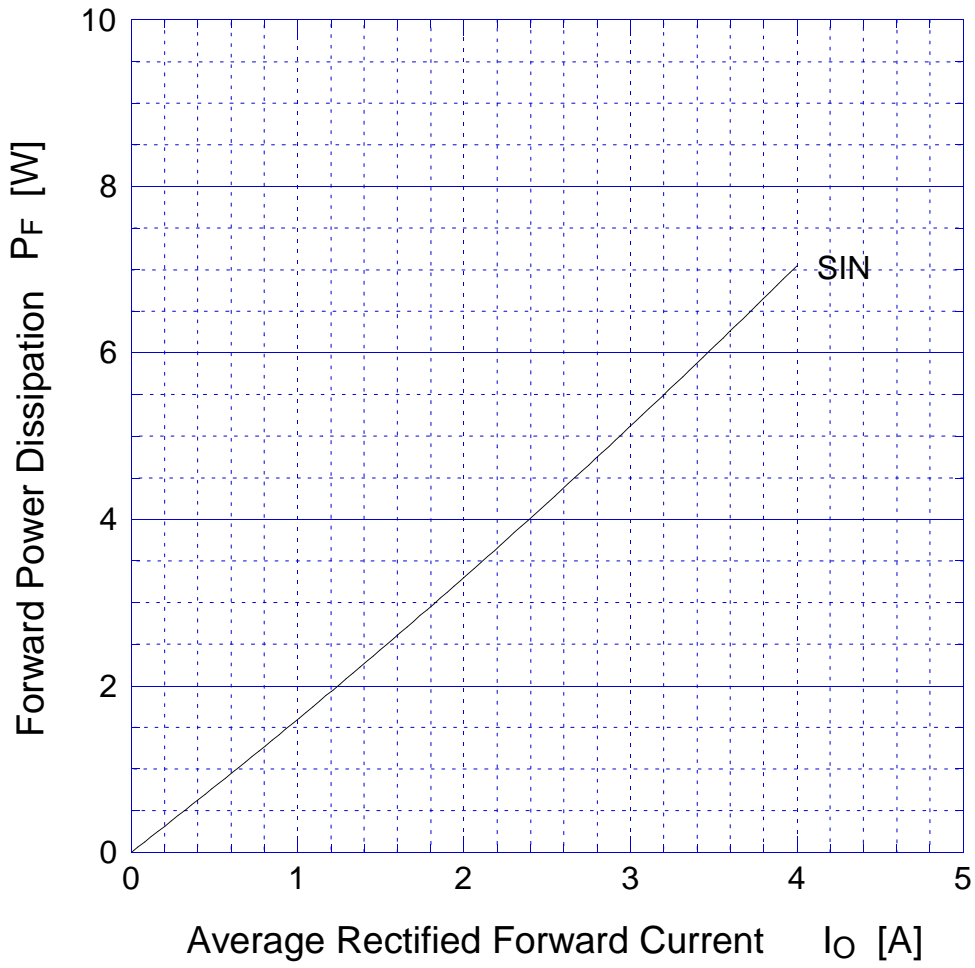

$T_j = 150^\circ\text{C}$

D4KB80R

Derating Curve

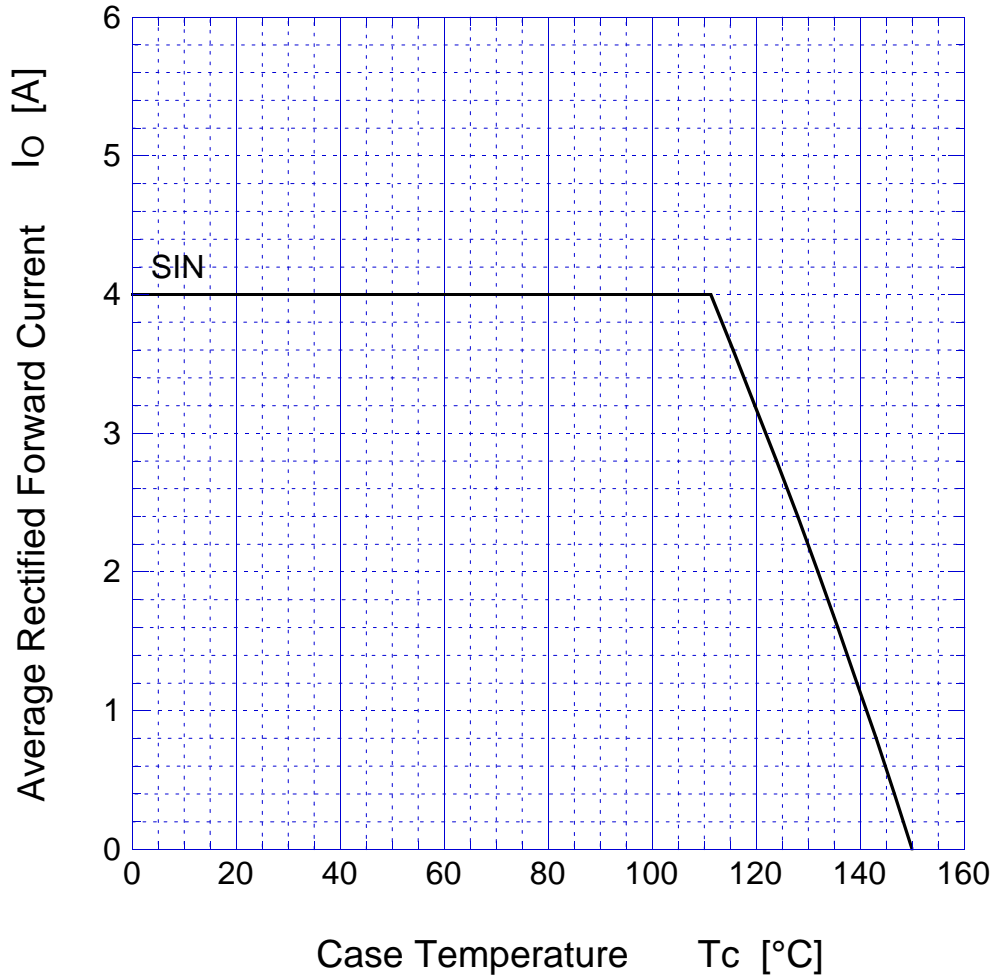

D4KB80R

Derating Curve

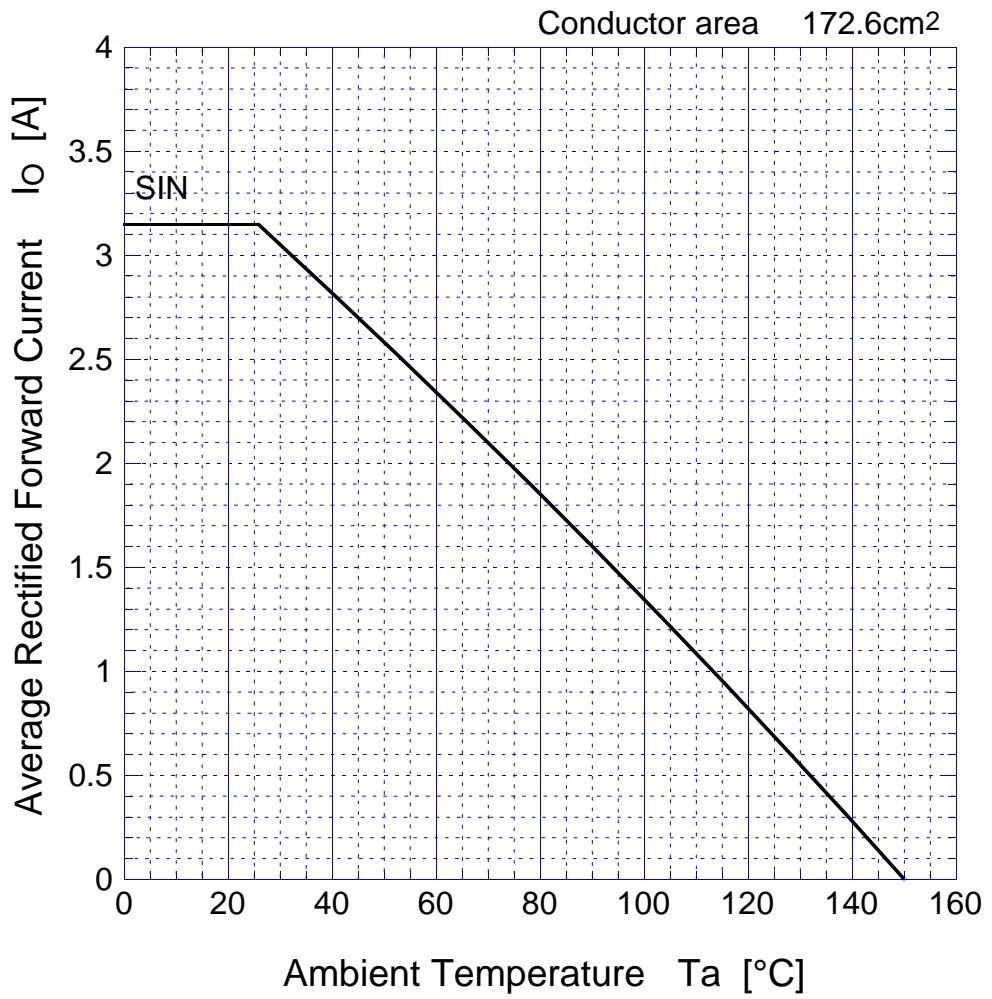

D4KB80R Peak Surge Forward Capability

