



NPN POWER DARLINGTON TRANSISTORS

D54FY7D

**80 VOLTS
7 AMP, 30 WATTS**

Designed for high power switching applications, hammer drive, pulse motor drive applications.

Features:

- High DC Current Gain:
 $h_{FE} = 2000$ (Min.) (at $V_{CE} = 3V, I_C = 3A$)
- Low Saturation Voltage:
 $V_{CE(sat)} = 1.5V$ (Max.) (at $I_C = 3A$)
- Complementary to D55FY7D
- Isolated TO-220 package

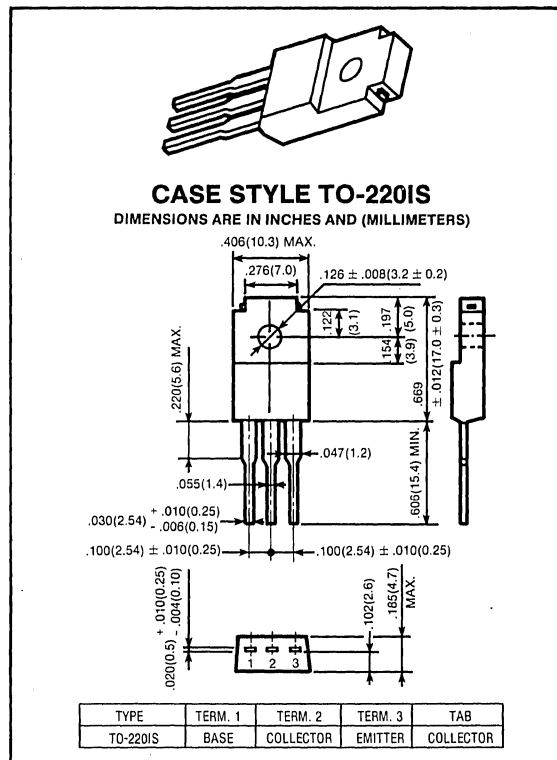
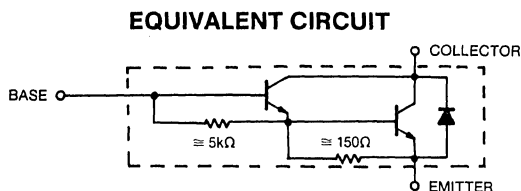

maximum ratings ($T_A = 25^\circ C$) (unless otherwise specified)

RATING	SYMBOL	D54FY7D	UNITS
Collector-Emitter Voltage	V_{CEO}	80	Volts
Collector-Base Voltage	V_{CBO}	80	Volts
Emitter Base Voltage	V_{EBO}	5	Volts
Collector Current — Continuous	I_C	7	A
Base Current — Continuous	I_B	0.2	A
Total Power Dissipation @ $T_C = 25^\circ C$	P_D	1.0	Watts
Operating and Storage Junction Temperature Range	T_J, T_{STG}	-55 to +150	$^\circ C$

thermal characteristics

Maximum Lead Temperature for Soldering Purposes: $\frac{1}{8}$ " from Case for 5 Seconds	T_L	260	$^\circ C$
--	-------	-----	------------

electrical characteristics ($T_A = 25^\circ\text{C}$) (unless otherwise specified)

CHARACTERISTIC	SYMBOL	MIN	TYP	MAX	UNIT
----------------	--------	-----	-----	-----	------

off characteristics

Collector-Emitter Breakdown Voltage ($I_C = 50\text{mA}$)	$V_{(BR)CEO}$	80	—	—	Volts
Collector Cutoff Current ($V_{CB} = 80\text{V}$)	I_{CBO}	—	—	100	μA
Emitter Cutoff Current ($V_{EB} = 5\text{V}$)	I_{EBO}	—	—	3.0	mA

second breakdown

Second Breakdown with Base Forward Biased	FBSOA	SEE FIGURE 9			
---	-------	--------------	--	--	--

on characteristics

DC Current Gain ($I_C = 3\text{A}, V_{CE} = 3\text{V}$) ($I_C = 7\text{A}, V_{CE} = 3\text{V}$)	h_{FE}	2000 1000	— —	15000 —	—
Collector-Emitter Saturation Voltage ($I_C = 3\text{A}, I_B = 6\text{mA}$) ($I_C = 7\text{A}, I_B = 14\text{mA}$)	$V_{CE(sat)}$	— —	0.9 1.2	1.5 2.0	V
Base-Emitter Saturation Voltage ($I_C = 3\text{A}, I_B = 6\text{mA}$)	$V_{BE(sat)}$	—	1.5	2.5	Volts

switching characteristics

Turn-on Time	$V_{CC} = 45\text{V}$ $I_{B1} = I_{B2} = 6\text{mA}$ Duty Cycle $\leq 1\%$	t_{on}	—	0.8	—	μs
Storage Time		t_{stg}	—	3.0	—	
Fall Time		t_f	—	2.5	—	

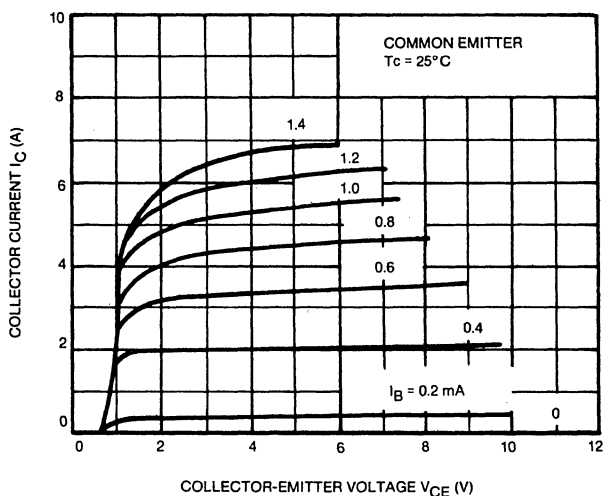

FIG. 1 $I_C - V_{CE}$

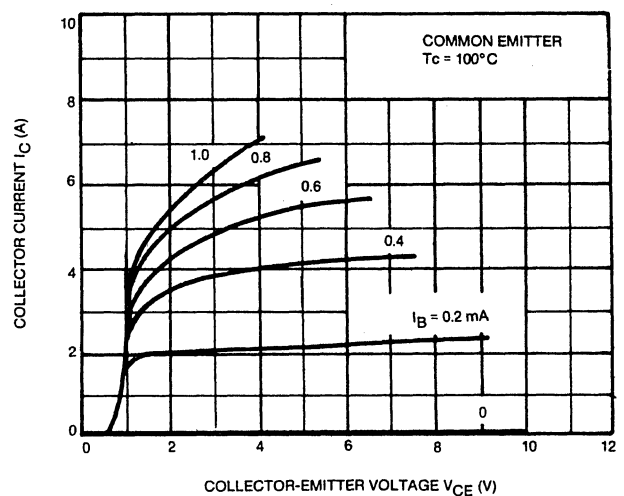

FIG. 2 $I_C - V_{CE}$

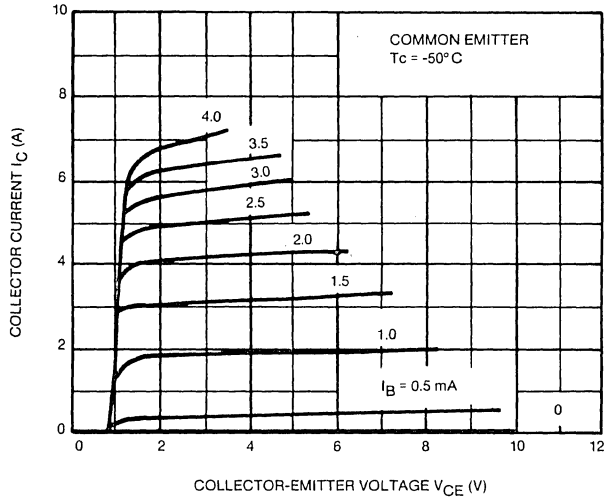

FIG. 3 I_C - V_{CE}

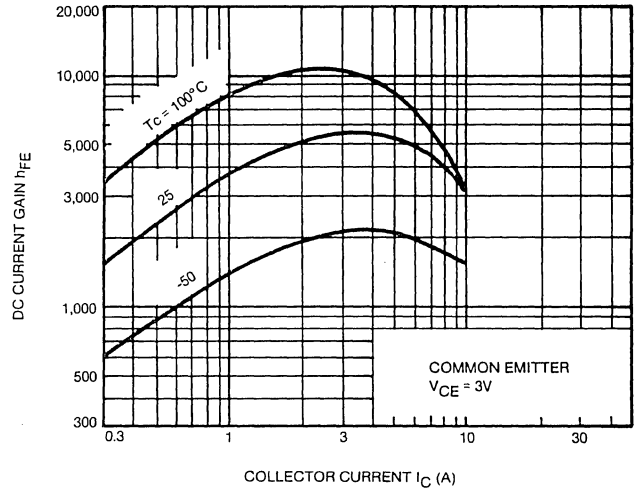

FIG. 4 h_{FE} - I_C

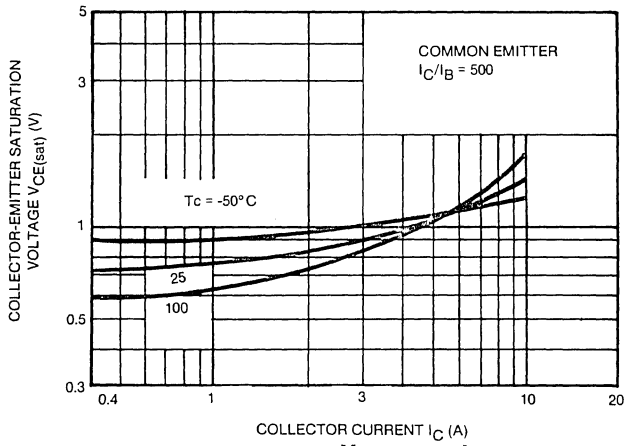

FIG. 5 V_{CE(sat)} - I_C

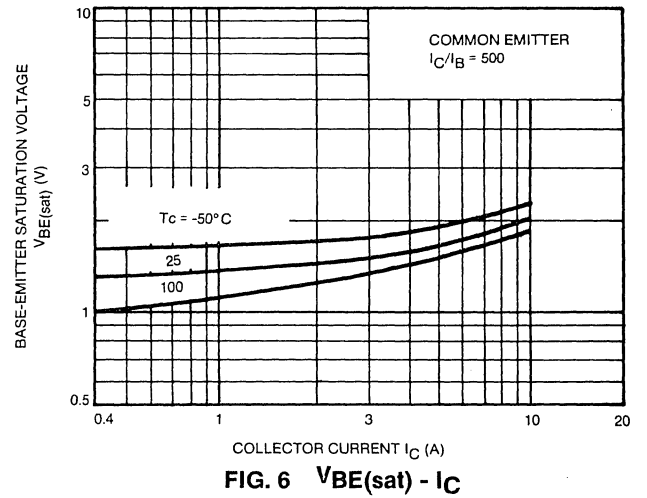

FIG. 6 V_{BE(sat)} - I_C

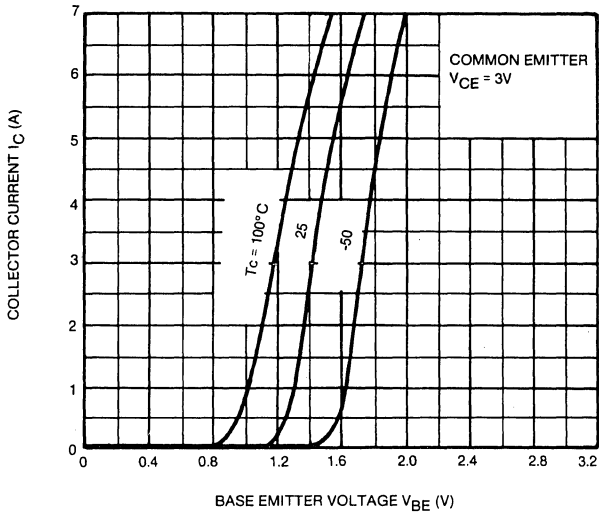

FIG. 7 I_C - V_{BE}

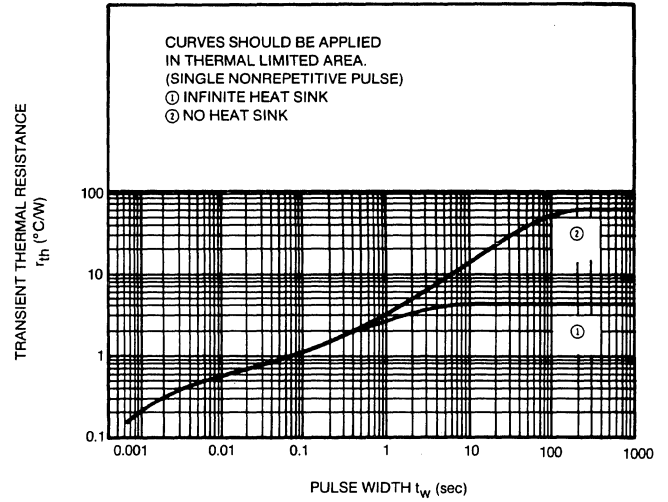

FIG. 8 r_{th} - t_w

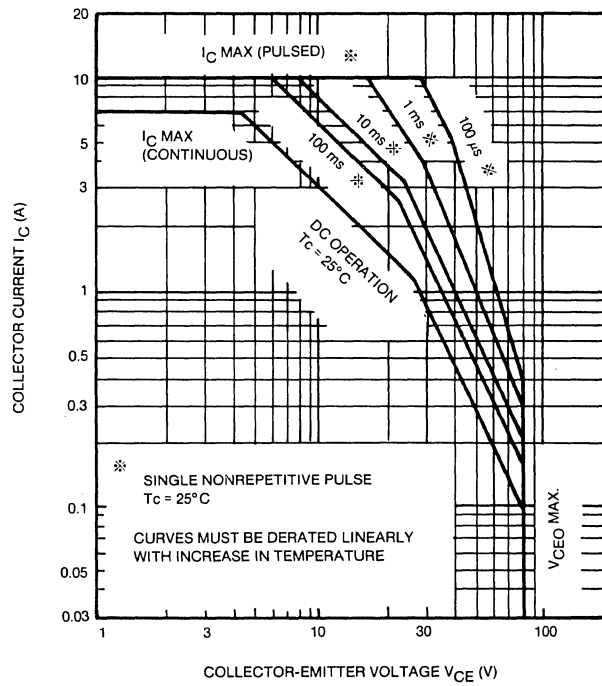

FIG. 9 SAFE OPERATING AREA