

NPN Power Switching Transistors 40-50-60 Amperes 400-500 Volts

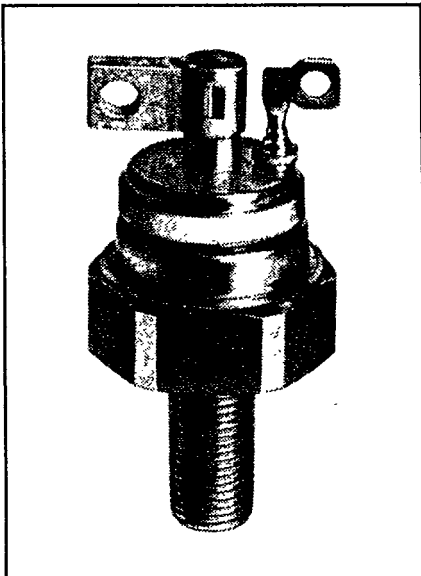

D60T ___40/50/60
 NPN Power Switching Transistors
 40-50-60 Amperes/400-500 Volts

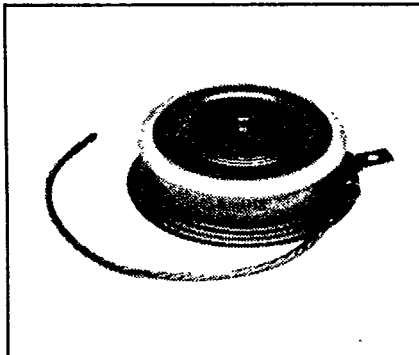

D62T ___40/50/60
 NPN Power Switching Transistors
 40-50-60 Amperes/400-500 Volts

Features:

- Triple Diffused Design
- Compression Bonded Construction/No Solder
- Double Sided Cooling on D62T
- Fast Switching
- 100 kHz Operation
- 200 Amperes Peak

Applications:

- High Frequency Inverters
- Motor Controls
- Switching Regulators
- VLF Transmitters
- Induction Heating
- Power Supplies

Ordering Information

Example: Select the complete ten digit part number you desire from the table—i.e. a D62T454010 describes a Disc Package Transistor rated at 450 Volts, 40 Amperes, and a gain of 10 at rated current (40 Amperes). D60T454010 is the same transistor in a stud package.

Type	V _{CEO} (SUS) Volts (×10)	Current Rating Amperes	Gain
D60T	40	40	10
D62T	45	50	
	50	60	

Powerex, Inc., Hillis Street, Youngwood, Pennsylvania 15697 (412) 925-7272

D60T/D62T__40, D60T/D62T__50, D60T/D62T__60
 NPN Power Switching Transistors
 40-50-60 Amperes/400-500 Volts

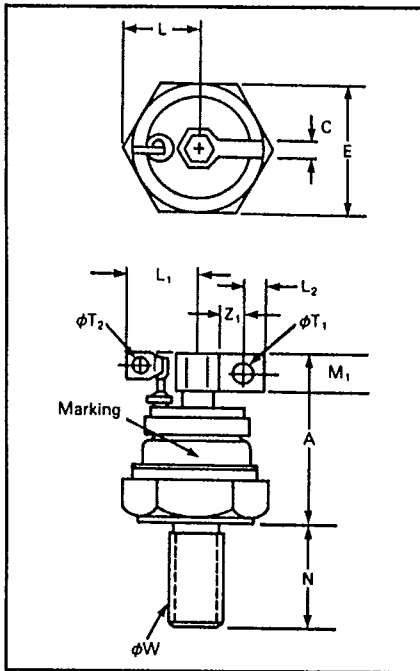

D60T__40/50/60, 400-500 Volts
 Outline Drawing

Dimension	Inches		Millimeters	
	Min.	Max.	Min.	Max.
A		1.80		45.72
C	.160	.180	4.06	4.57
E	1.212	1.252	30.78	31.75
L		.812		20.62
L ₁		.64		16.26
L ₂	.155		3.94	
M ₁	.350	.450	8.88	11.42
N	1.040	1.077	24.89	27.69
phi T ₁	.193	.203	4.90	5.16
phi T ₂	.145	.160	3.68	4.06
Z ₁	.22		5.59	
phi W	1/2-20 UNF 3A			

Creep and Strike Distance:

D60T- 17 in. min. (4.3mm).

(In accordance with NEMA standards.)

Finish—Nickel Plate,

Approx. Weight—4.9 oz. (140 g).

1. Complete threads to extend to within 2½ threads of seating plane.
2. Angular orientation of terminals is undefined.
3. Pitch diameter of 1/2-20 UNF 3A (COATED) threads (ASA B1.1-1960).

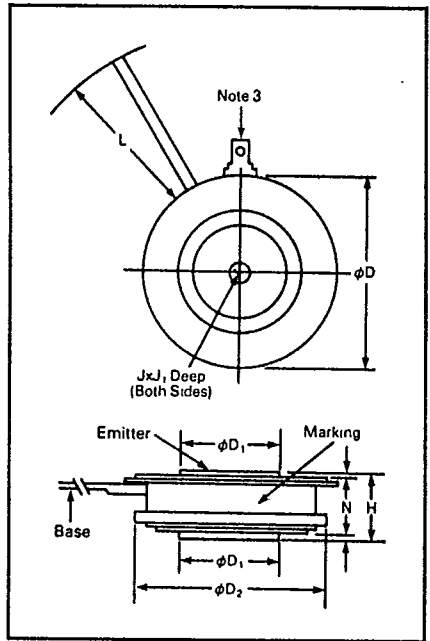

D62T__40/50/60, 400-500 Volts
 Outline Drawing

Dimension	Inches		Millimeters	
	Min.	Max.	Min.	Max.
phi D	1.610	1.650	40.89	41.91
phi D ₁	.745	.755	18.92	19.18
phi D ₂	1.420	1.460	36.07	37.08
H	.500	.560	12.70	14.22
phi J	.135	.145	3.43	3.68
J ₁	.072	.082	1.83	2.08
L	4.000		101.6	
N	.030		.76	

Creep Distance—.34 in. min. (8.64mm)

Strike Distance—.52 in. min. (13.21mm)

(In accordance with NEMA standards.)

Finish—Nickel Plate.

Approx. Weight—2.1 oz. (60g).

1. Dimension "H" is a clamped dimension.

2. Base Lead is No. 14 uninsulated flexible stranded wires.

3. Emitter tab for 3/16 inch fast-on terminal.

Powerex, Inc., Hillis Street, Youngwood, Pennsylvania 15697 (412) 925-7272

D60T/D62T___40, D60T/D62T___50, D60T/D62T___60

NPN Power Switching Transistors

40-50-60 Amperes/400-500 Volts

D60T Maximum Ratings

Characteristics	Symbol	D60T___40/50/60	Units
Operating and Storage Temperature	T_J/T_{STG}	- 65 to 200	°C
Emitter Base Voltage	V_{EBO}	7	Volts
Peak Collector Current	I_C Peak	200	Amperes
Continuous Collector Current ^①	I_C Cont.	—	Amperes
Continuous Base Current	I_B	20	Amperes
Linear Power Derating Factor from $T_C = 25^\circ\text{C}$ to $T_C = 175^\circ\text{C}$	—	5.88	W/°C
Thermal Resistance Case to Sink, Lubricated	$R_{\theta CS}$	0.12	°C/W
Thermal Resistance, Junction to Case	$R_{\theta JC}$	0.17	°C/W
Power Dissipation $T_C = 25^\circ\text{C}$	P_T	885	Watts
Power Dissipation $T_C = 75^\circ\text{C}$	P_T	590	Watts
Mounting Torque Non-Lubricated Threads		130	in.-lb.
Mounting Torque Non-Lubricated Threads		14.46	N-M

		D60T4040 D60T4050 D60T4060	D60T4540 D60T4550 D60T4560	D60T5040 D60T5050 D60T5060	
Collector Emitter Sustaining Voltage ^②	$V_{CE(sus)}$	400	450	500	Volts
Collector Base Voltage	V_{CBO}	450	500	550	Volts
Collector Emitter Voltage $V_{BE} = -1.5V$	V_{CEV}	450	500	550	Volts

① Collector current limited by base current. Base current must not exceed 20 Amperes, RMS, 28 Amperes square wave 50% duty cycle or 40 Amperes peak ½ sine wave.

② $V_{CE(sus)}$ must not be measured on a curve tracer.

Powerex, Inc., Hillis Street, Youngwood, Pennsylvania 15697 (412) 925-7272

D60T/D62T___40, D60T/D62T___50, D60T/D62T___60

NPN Power Switching Transistors

40-50-60 Amperes/400-500 Volts

D62T Maximum Ratings

Characteristics	Symbol	D62T___40/50/60			Units
Operating and Storage Temperature	T_J/T_{STG}	- 65 to 200			$^{\circ}\text{C}$
Emitter Base Voltage	V_{EBO}	7			Volts
Peak Collector Current	I_C Peak	200			Amperes
Continuous Collector Current ^①	I_C Cont.	—			Amperes
Continuous Base Current	I_B	20			Amperes
Linear Power Derating Factor from $T_C = 25^{\circ}\text{C}$ to $T_C = 175^{\circ}\text{C}$	—	11.11			$\text{W}/^{\circ}\text{C}$
Thermal Impedance, Double Sided Cooling Case to Sink, Lubricated	$R_{\theta CS}$	0.05			$^{\circ}\text{C}/\text{W}$
Thermal Impedance, Junction to Case	$R_{\theta JC}$	0.09			$^{\circ}\text{C}/\text{W}$
Power Dissipation $T_C = 25^{\circ}\text{C}$	P_T	1650			Watts
Power Dissipation $T_C = 75^{\circ}\text{C}$	P_T	1100			Watts
Mounting Force		900			lb.
Mounting Force		4.05			kN
		D62T4040 D62T4050 D62T4060	D62T4540 D62T4550 D62T4560	D62T5040 D62T5050 D62T5060	
Collector Emitter Sustaining Voltage ^②	$V_{CEO(SUS)}$	400	450	500	Volts
Collector Base Voltage	V_{CBO}	450	500	550	Volts
Collector Emitter Voltage $V_{BE} = -1.5\text{V}$	V_{CEV}	450	500	550	Volts

① Collector current limited by base current. Base current must not exceed 20 Amperes, RMS, 28 Amperes square wave 50% duty cycle or 40 Amperes peak 1/2 sine wave.

② $V_{CEO(SUS)}$ must not be measured on a curve tracer.



Powerex, Inc., Hillis Street, Youngwood, Pennsylvania 15697 (412) 925-7272

D60T/D62T___40, D60T/D62T___50, D60T/D62T___60

NPN Power Switching Transistors

40-50-60 Amperes/400-500 Volts

Electrical and Mechanical Characteristics $T_c, T_j = 25^\circ\text{C}$ unless otherwise specified

Characteristics	Symbol	Test Conditions	Min.	D60T/D62T___40/50/60		Units
				Typ.	Max.	
Collector Cutoff Current (Base Emitter Reverse Biased)	I_{CEV}	At Rated V_{CEV} $V_{BE(OFF)} = -1.5V$	—	0.1	1	mA
Collector Cutoff Current (Base Emitter Reverse Biased)	I_{CEV}	At Rated V_{CEV} $V_{BE(OFF)} = -1.5V, T_j = 150^\circ\text{C}$	—	0.8	3	mA
Emitter Cutoff Current	I_{EBO}	$V_{EB} = 7V$	—	2	30	mA
Output Capacitance	C_{OB}	$f_{TEST} = 1\text{ MHz}, V_{CB} = 10V$	—	2500	—	μf
Gain-Bandwidth	f_T	$f_{TEST} = 1\text{ MHz}, I_C = 5A, V_{CE} = 10V$	7	10	—	MHz
D60T/D62T___40						
DC Current Gain	h_{FE}	$I_C = 40A, V_{CE} = 2.5V$	10	—	—	—
		$I_C = 40A, V_{CE} = 5V$	10	—	—	—
		$I_C = 80A, V_{CE} = 2.5V$	—	5	—	—
Collector-Emitter Saturation Voltage	$V_{CE(SAT)}$	$I_C = 40A, I_B = 6A$	—	—	1.25	Volts
		$I_C = 40A, I_B = 4.8A$	—	—	1.25	Volts
Base-Emitter Saturation Voltage	$V_{BE(SAT)}$	$I_C = 40A, I_B = 6A$	—	—	1.50	Volts
		$I_C = 40A, I_B = 4.8A$	—	—	1.40	Volts
Resistive Load	Turn-On Delay	$V_{CC} = 250V, I_C = 40A$	—	—	110	ns
	Rise Time	$I_{B1} = -I_{B2} = 6A$	—	0.7	1.0	μs
Switch Times	Storage Time	$t_p = 50\ \mu\text{s}$	—	1.25	3.0	μs
	Fall Time	Duty Cycle < 2%	—	0.3	0.5	μs
D60T/D62T___50						
DC Current Gain	h_{FE}	$I_C = 50A, V_{CE} = 2.5V$	10	—	—	—
		$I_C = 100A, V_{CE} = 2.5V$	—	5	—	—
Collector-Emitter Saturation Voltage	$V_{CE(SAT)}$	$I_C = 50A, I_B = 6A$	—	—	1.25	Volts
Base-Emitter Saturation Voltage	$V_{BE(SAT)}$	$I_C = 50A, I_B = 6A$	—	—	1.50	Volts
Resistive Load	Turn-On Delay	$V_{CC} = 250V, I_C = 50A$	—	—	120	ns
	Rise Time	$I_{B1} = -I_{B2} = 7.5A$	—	0.8	1.10	μs
Switch Times	Storage Time	$t_p = 50\ \mu\text{s}$	—	1.75	3.0	μs
	Fall Time	Duty Cycle < 2%	—	0.35	0.5	μs
D60T/D62T___60						
DC Current Gain	h_{FE}	$I_C = 60A, V_{CE} = 2.5V$	10	—	—	—
		$I_C = 120A, V_{CE} = 2.5V$	—	5	—	—
Collector-Emitter Saturation Voltage	$V_{CE(SAT)}$	$I_C = 60A, I_B = 6A$	—	—	1.25	Volts
Base-Emitter Saturation Voltage	$V_{BE(SAT)}$	$I_C = 60A, I_B = 6A$	—	—	1.60	Volts
Resistive Load	Turn-On Delay	$V_{CC} = 250V, I_C = 60A$	—	—	150	ns
	Rise Time	$I_{B1} = -I_{B2} = 9A$	—	0.85	1.20	μs
Switch Times	Storage Time	$t_p = 50\ \mu\text{s}$	—	2.0	3.0	μs
	Fall Time	Duty Cycle < 2%	—	0.35	0.5	μs

Powerex, Inc., Hillis Street, Youngwood, Pennsylvania 15697 (412) 925-7272

D60T/D62T___40, D60T/D62T___50, D60T/D62T___60
 NPN Power Switching Transistors
 40-50-60 Amperes/400-500 Volts

DC CURRENT GAIN (TYPICAL)
 D60T/D62T___40

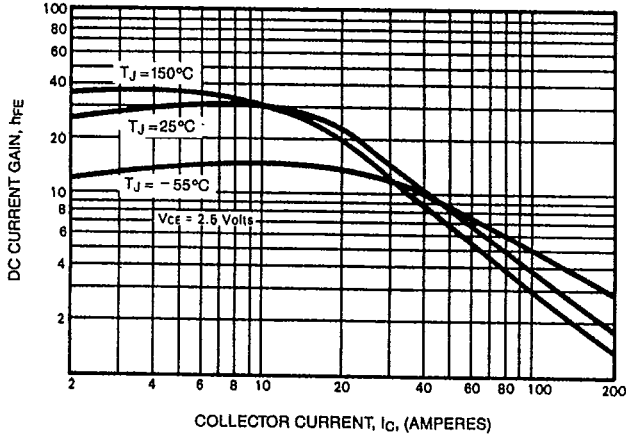

SATURATION VOLTAGE (TYPICAL)
 D60T/D62T___40

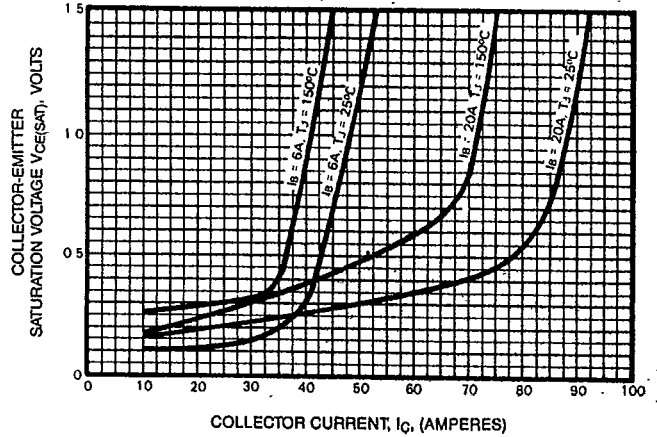

DC CURRENT GAIN (TYPICAL)
 D60T/D62T___50

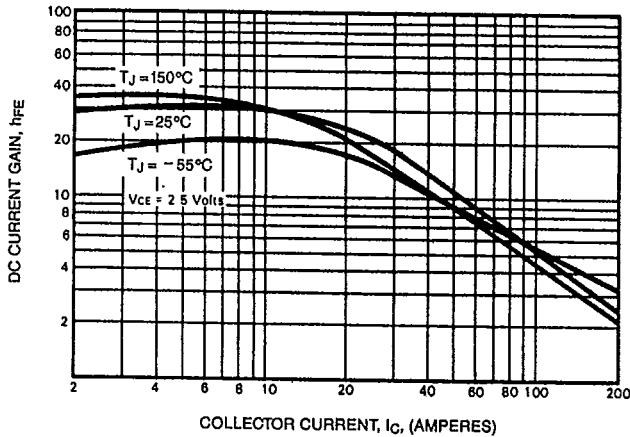

SATURATION VOLTAGE (TYPICAL)
 D60T/D62T___50

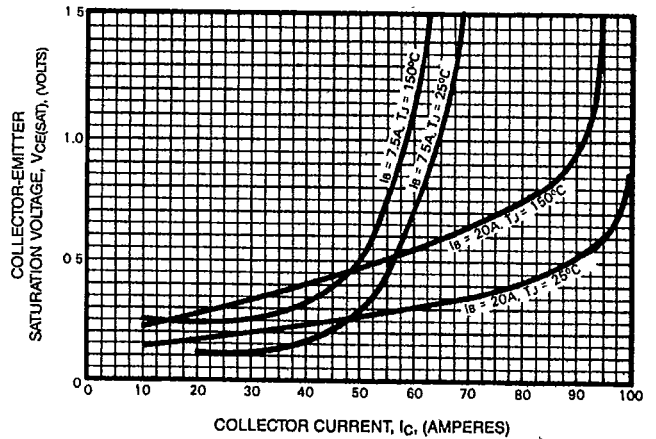

DC CURRENT GAIN (TYPICAL)
 D60T/D62T___60

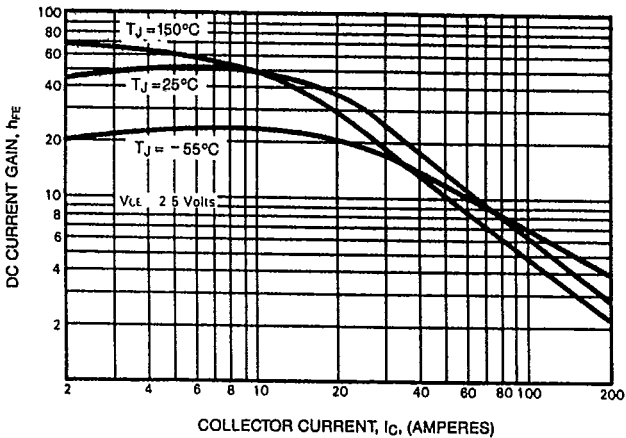

SATURATION VOLTAGE (TYPICAL)
 D60T/D62T___60

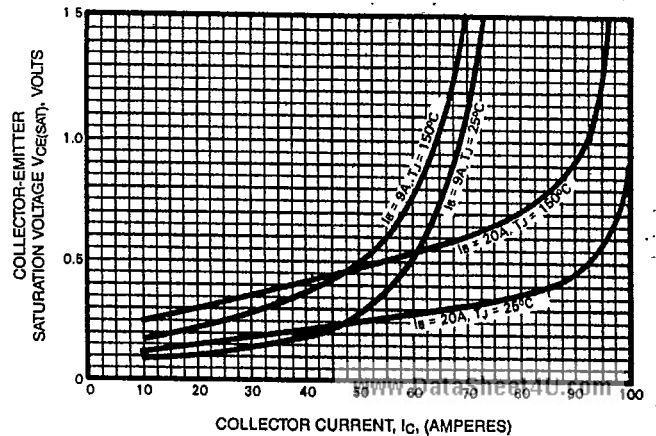

Powerex, Inc., Hillis Street, Youngwood, Pennsylvania 15697 (412) 925-7272

D60T/D62T___40, D60T/D62T___50, D60T/D62T___60
NPN Power Switching Transistors
 40-50-60 Amperes/400-500 Volts

TRANSFER CHARACTERISTICS (TYPICAL)
D60T/D62T___40

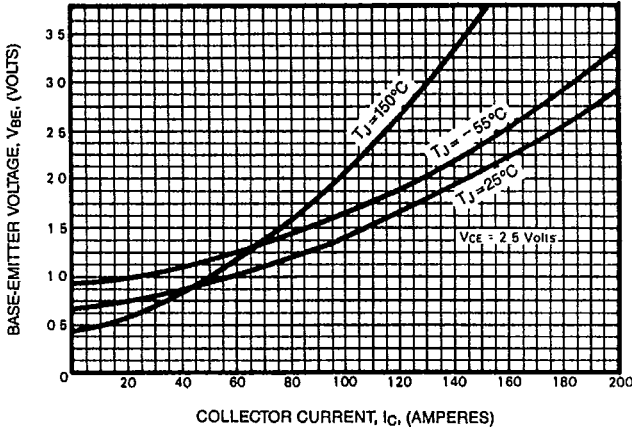

RESISTIVE SWITCHING (TYPICAL)
D60T/D62T___40

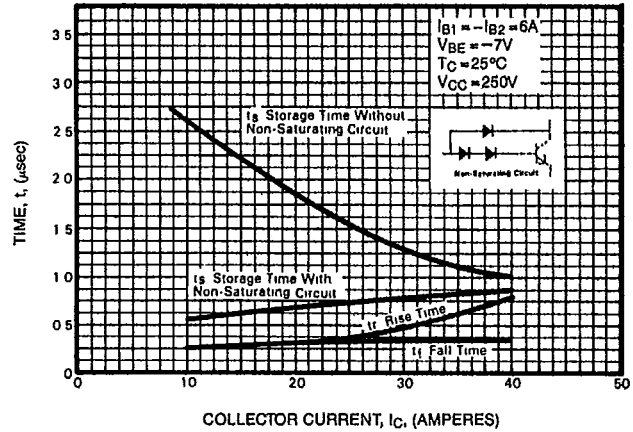

TRANSFER CHARACTERISTICS (TYPICAL)
D60T/D62T___50

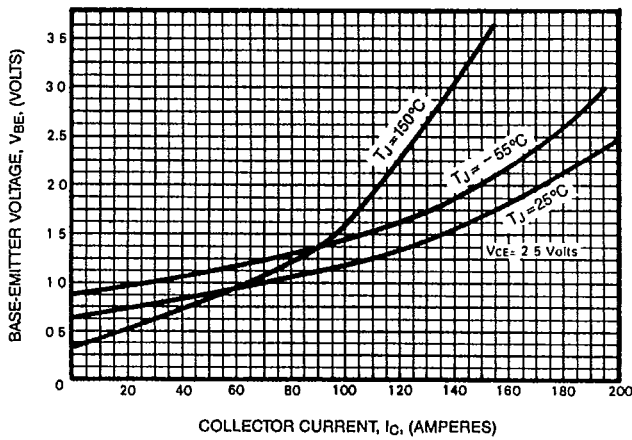

RESISTIVE SWITCHING (TYPICAL)
D60T/D62T___50

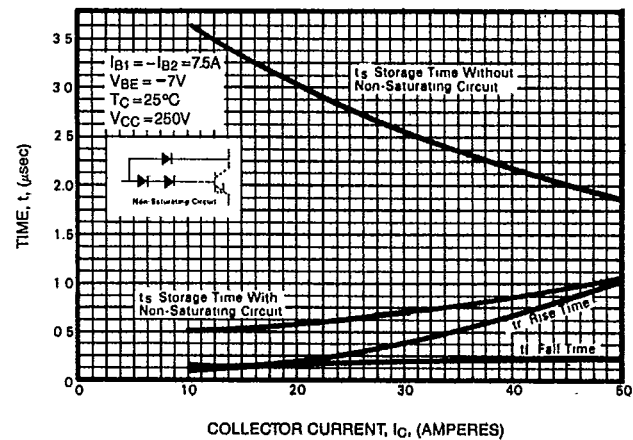

TRANSFER CHARACTERISTICS (TYPICAL)
D60T/D62T___60

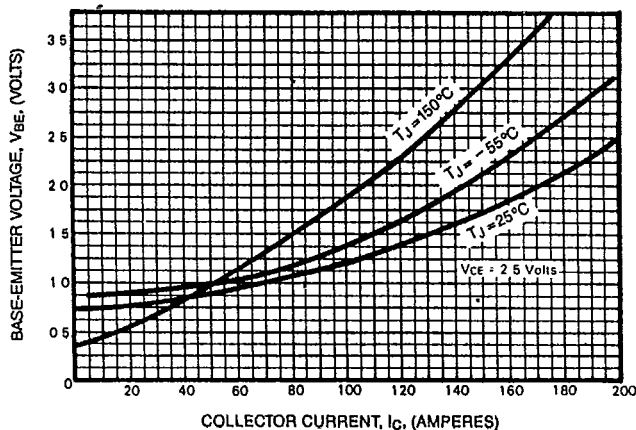

RESISTIVE SWITCHING (TYPICAL)
D60T/D62T___60

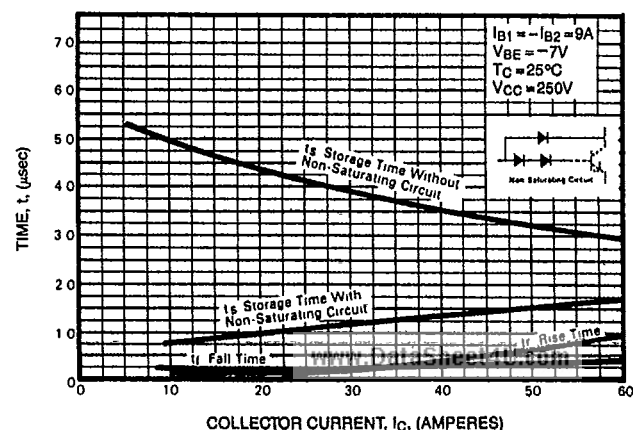

Powerex, Inc., Hillis Street, Youngwood, Pennsylvania 15697 (412) 925-7272

D60T/D62T___40, D60T/D62T___50, D60T/D62T___60
 NPN Power Switching Transistors
 40-50-60 Amperes/400-500 Volts

**TURN-OFF TIME FOR CLAMPED
 INDUCTIVE SWITCHING (TYPICAL)
 D60T/D62T___40**

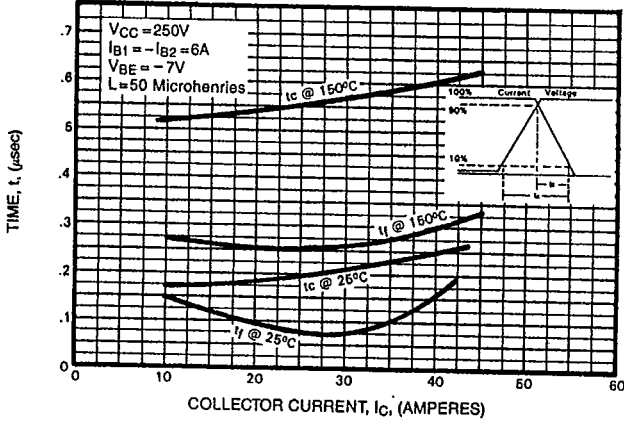

**STORAGE TIME FOR
 CLAMPED INDUCTIVE SWITCHING (TYPICAL)
 D60T/D62T___40**

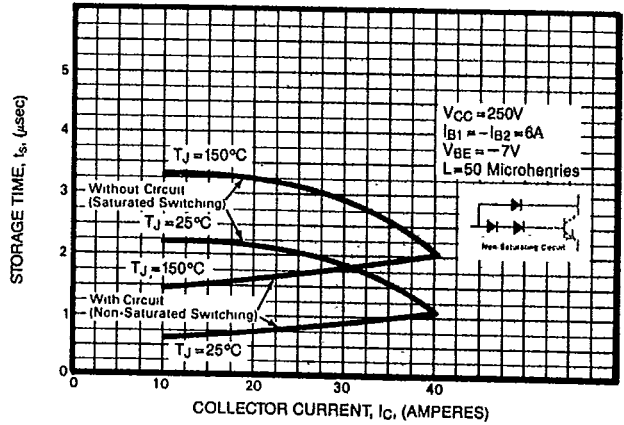

**TURN-OFF TIME FOR CLAMPED
 INDUCTIVE SWITCHING (TYPICAL)
 D60T/D62T___50**

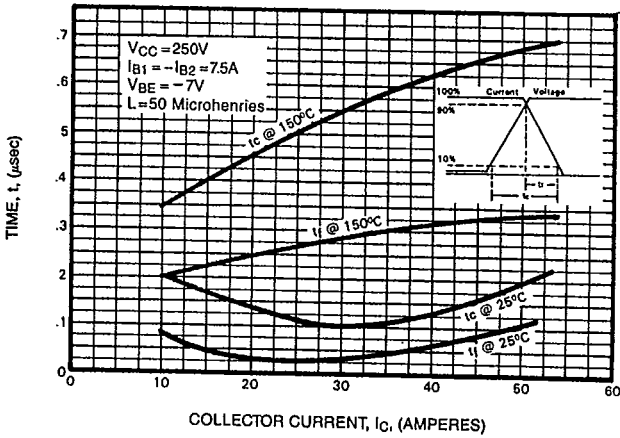

**STORAGE TIME FOR
 CLAMPED INDUCTIVE SWITCHING (TYPICAL)
 D60T/D62T___50**

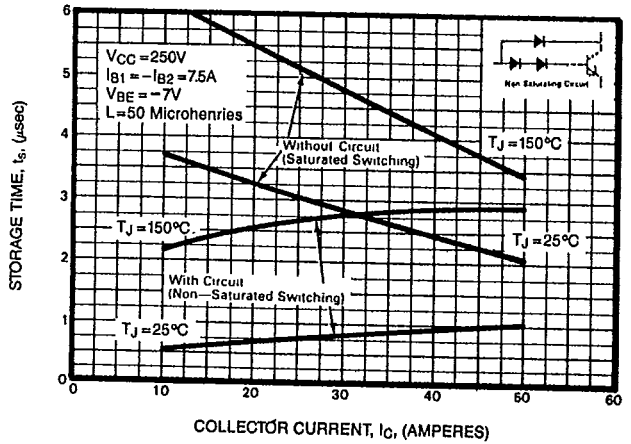

**TURN-OFF TIME FOR CLAMPED
 INDUCTIVE SWITCHING (TYPICAL)
 D60T/D62T___60**

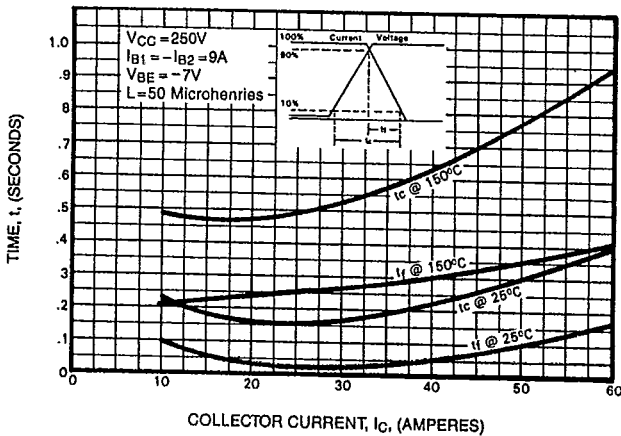

**STORAGE TIME FOR
 CLAMPED INDUCTIVE SWITCHING (TYPICAL)
 D60T/D62T___60**

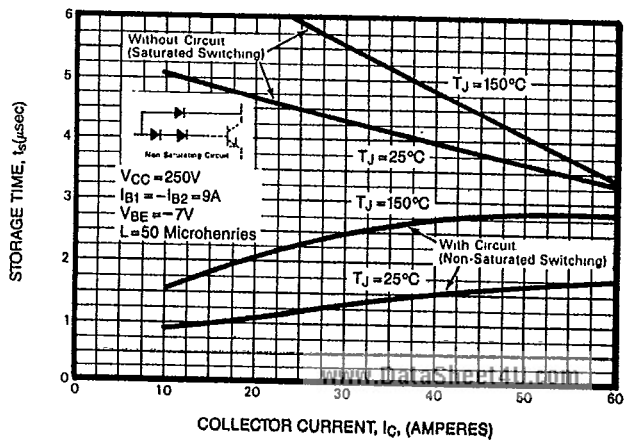

Powerex, Inc., Hillis Street, Youngwood, Pennsylvania 15697 (412) 925-7272

D60T/D62T ___40, D60T/D62T ___50, D60T/D62T ___60
 NPN Power Switching Transistors
 40-50-60 Amperes/400-500 Volts

FORWARD BIAS SAFE OPERATING AREA (S.O.A.) D60T

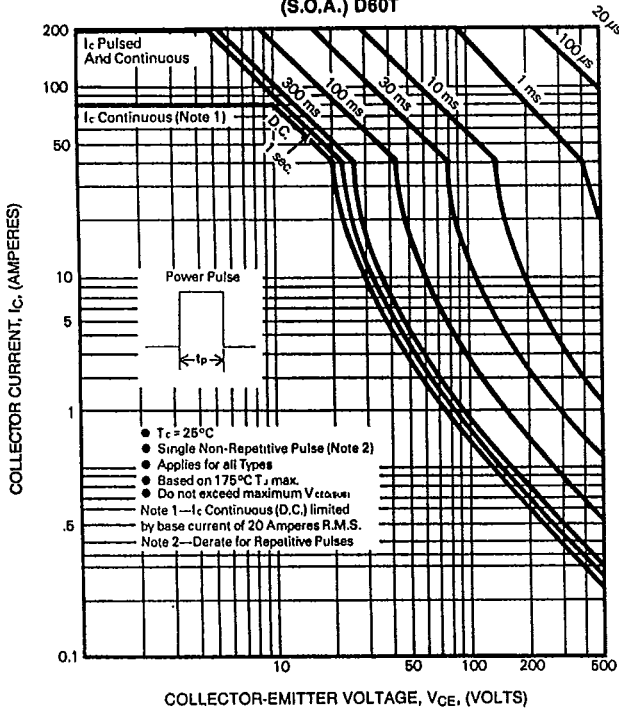

FORWARD BIAS SAFE OPERATING AREA (S.O.A.) D62T

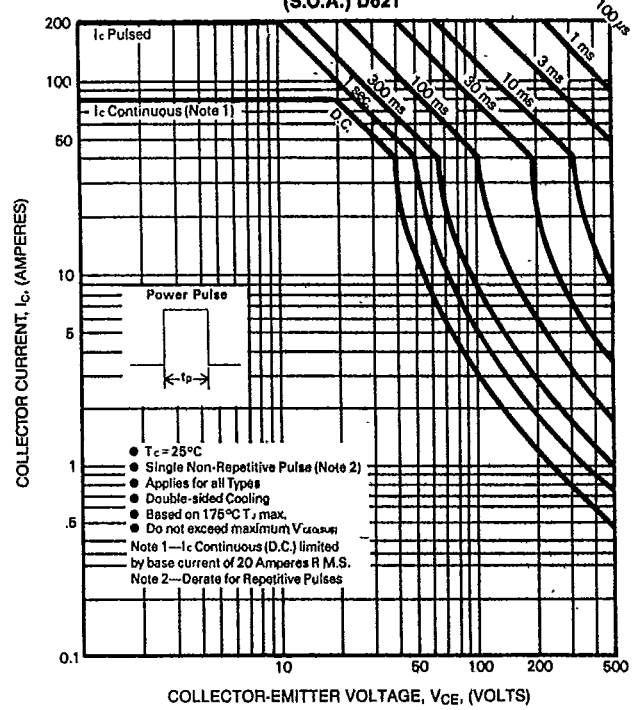

TRANSIENT THERMAL IMPEDANCE CHARACTERISTICS D60T/D62T

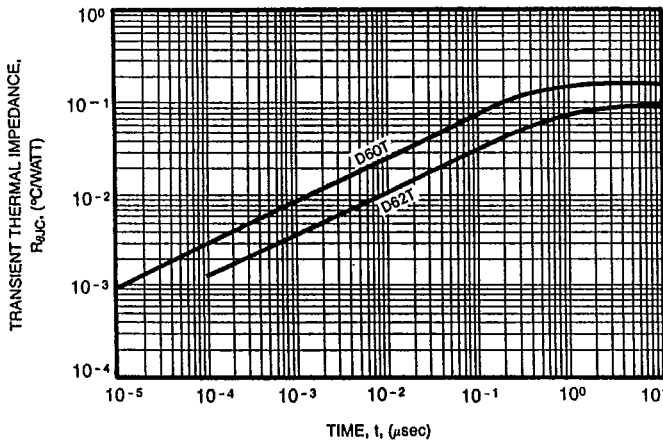

REVERSE BIAS SAFE OPERATING AREA (R.B.S.O.A.) D60T/D62T

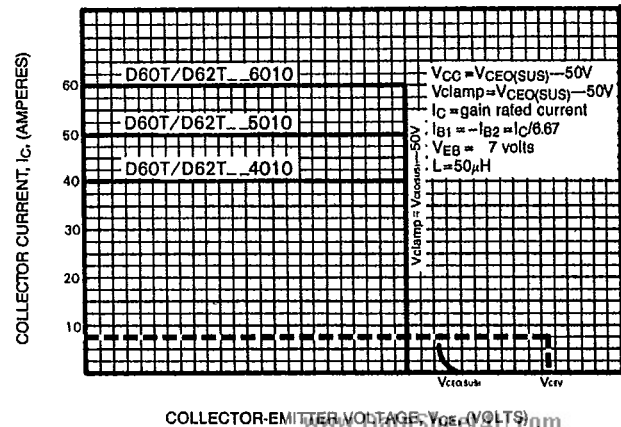

Powerex, Inc., Hillis Street, Youngwood, Pennsylvania 15697 (412) 925-7272

D60T/D62T___40, D60T/D62T___50, D60T/D62T___60
NPN Power Switching Transistors
40-50-60 Amperes/400-500 Volts

Typical Turn-Off Waveforms for Clamped Inductive Switching*

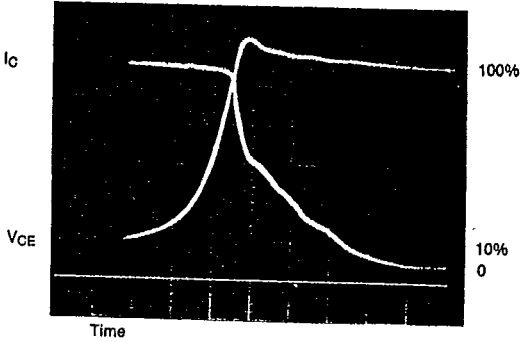

D60T___40
D62T___40

$V_{CE} = 250V$, 50V/cm
 $I_C = 40A$, scale not calibrated
 $I_{B1} = -I_{B2} = 6A$, $V_{EB} = 7V$
Time = 100 ns/cm
 $T = 150^\circ C$

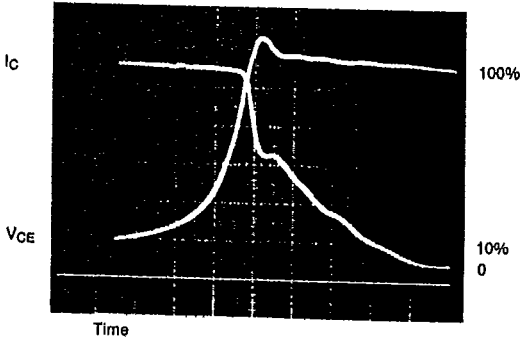

D60T___50
D62T___50

$V_{CE} = 250V$, 50V/cm
 $I_C = 50A$, 10A/cm
 $I_{B1} = -I_{B2} = 7.5A$, $V_{EB} = 7V$
Time = 100 ns/cm
 $T = 150^\circ C$

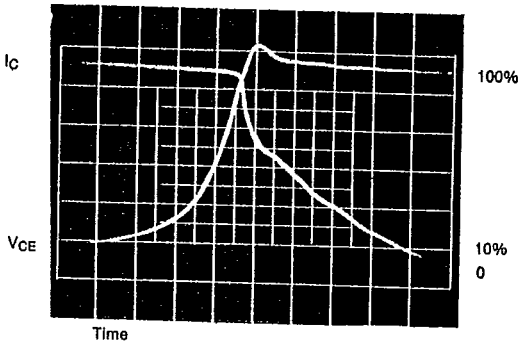

D60T___60
D62T___60

$V_{CE} = 250V$, 50V/cm
 $I_C = 60A$, scale not calibrated
 $I_{B1} = -I_{B2} = 9A$, $V_{EB} = 7V$
Time = 100 ns/cm
 $T = 150^\circ C$

*Shown above are actual photographs taken during 150°C Inductive switching measurements