

Multi DomiLED

Synonymous with function and performance, the Multi DomiLED series is perfectly suited for a variety of cross-industrial applications due to its small package outline, durability and superior brightness.



Features:

- > High brightness tri-color surface mount LED.
- > Each color can be individually controlled
- > 120° viewing angle.
- > Small package outline (LxWxH) of 3.2 x 3.0 x 1.7mm.
- > Qualified according to JEDEC moisture sensitivity Level 2.
- > Compatible to IR reflow soldering.
- > Environmental friendly; RoHS compliance.
- > Passed Corrosion Resistant Test. *Appx. 6.1*
- > Compliance to automotive standard; AEC-Q101.



Applications:

- > Automotive: Interior applications, eg: switches, telematics, climate control system, dashboard, etc.
- > Signs: full color video
- > Consumer & Communication: backlighting of LCDs
- > General Lighting: architectural lighting, decorative lighting

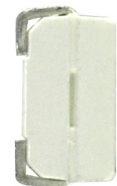

Optical Characteristics at Tj=25°C

Part Ordering Number	Color, λ_{dom} (nm)			Luminous Intensity @ If = 20mA IV (mcd) <i>Appx. 1.1</i>		
	Chip #1	Chip #2	Chip #3	Chip #1	Chip #2	Chip #3
● D6RTB-FJG-U2V+W3X3+S2T-1	Red 625nm	True Green 528nm	Blue 465nm	560.0-1125.0	1000.0-2100.0	224.0-450.0

● Not for new design

Electrical Characteristics at Tj=25°C

	V_f @ If = 20mA <i>Appx. 3.1</i>			V_r @ Ir = 10uA <i>Appx. 7.1</i>
	Min. (V)	Typ. (V)	Max. (V)	Min. (V)
Red	1.90	2.10	2.50	12
True Green	2.80	3.10	3.40	5
Blue	2.80	3.10	3.40	5

Absolute Maximum Ratings

	Maximum Value	Unit
DC forward current	Red; AllInGaP=50; True Green, Blue; InGaN=50	mA
Peak pulse current; (tp ≤ 10μs, Duty cycle = 0.005)	Red ; AllInGaP=200 True Green, Blue; InGaN=200	mA
Reverse voltage <i>Appx. 7.1</i>	Red; AllInGaP=12; True Green, Blue; InGaN= 5	V
ESD threshold (HBM)	2000	V
LED junction temperature	125	°C
Operating temperature	-40 ... +115	°C
Storage temperature	-40 ... +125	°C
Thermal resistance junction/ambient (3 chips on)		
Red, R _{th JA}	440	K/W
Blue & True Green, R _{th JA}	320	K/W
Thermal resistance junction/solder (3 chips on), R _{th JS}	180	K/W

Wavelength Grouping

Color	Group	Wavelength distribution (nm) <small>Appx. 2.2</small>
Red	Full	619 - 629
True Green	Full	521 - 536
	A	521 - 526
	B	526 - 531
	C	531 - 536
Blue	Full	459 - 471
	A	459 - 463
	B	463 - 467
	C	467 - 471

Luminous Intensity Group at Tj=25°C

Color	Brightness Group	Luminous Intensity <small>Appx. 1.1</small> IV (mcd)
Red	U2	560.0 ... 715.0
	V1	715.0 ... 900.0
	V2	900.0 ... 1125.0
True Green	W3	1000.0 ... 1300.0
	W4	1300.0 ... 1700.0
	X3	1700.0 ... 2100.0
Blue	S2	224.0 ... 285.0
	T1	285.0 ... 355.0
	T2	355.0 ... 450.0

Relative Luminous Intensity Vs Forward Current (Red)
 $I_V/I_V(20\text{mA}) = f(I_F); T_j = 25^\circ\text{C}$

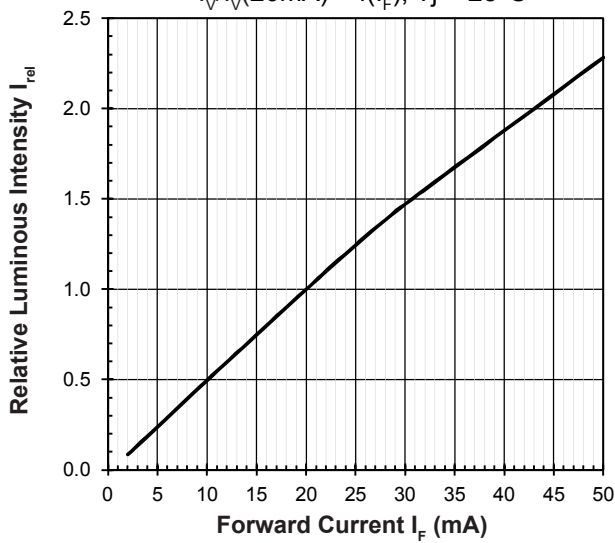

Relative Luminous Intensity Vs Forward Current (Blue & True Green)
 $I_V/I_V(20\text{mA}) = f(I_F); T_j = 25^\circ\text{C}$

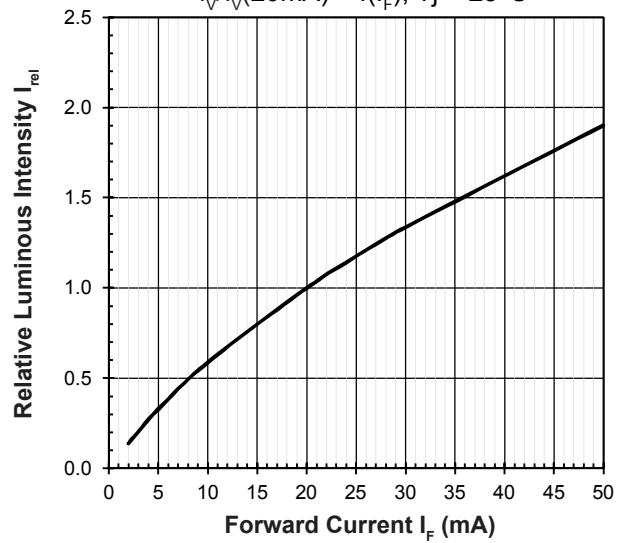

Forward Current Vs Forward Voltage (Red)
 $I_F = f(V_F); T_j = 25^\circ\text{C}$

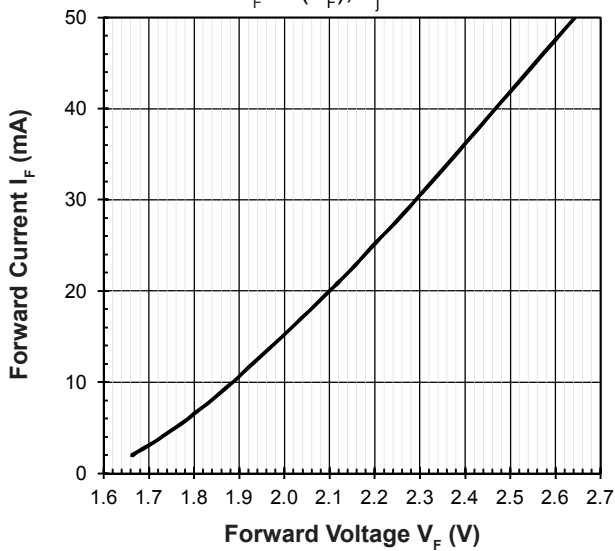

Forward Current Vs Forward Voltage (Blue & True Green)
 $I_F = f(V_F); T_j = 25^\circ\text{C}$

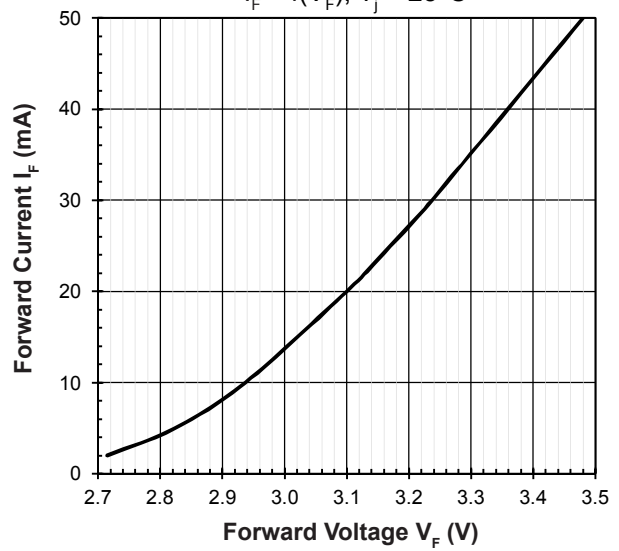

Maximum Current Vs Temperature
 $I_F = f(T)$

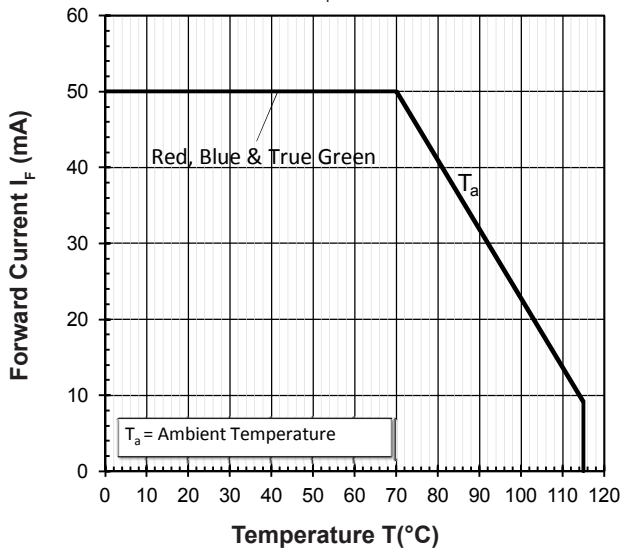

Relative Spectral Emission
 $I_{rel} = f(\lambda); T_j = 25^\circ\text{C}; I_F = 20\text{mA}$

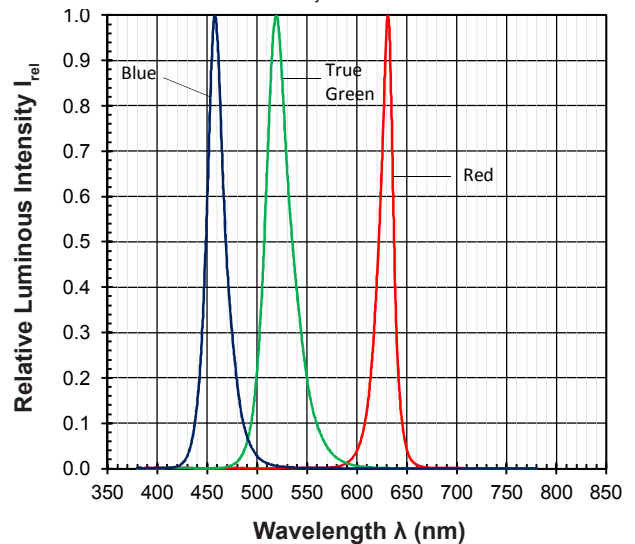

Allowable Forward Current Vs Duty Ratio
 ($T_j = 25^\circ\text{C}$; $t_p \leq 10\mu\text{s}$)



Relative Wavelength Shift Vs Forward Current
 $\lambda_{\text{dom}} = f(I_F)$; $T_j = 25^\circ\text{C}$

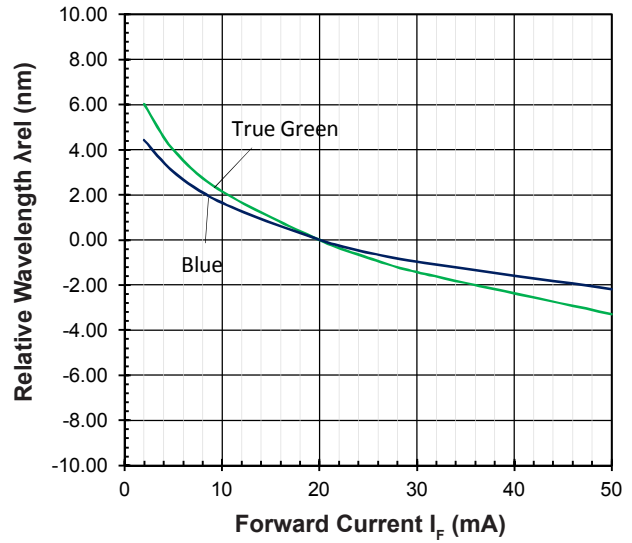

Radiation Pattern

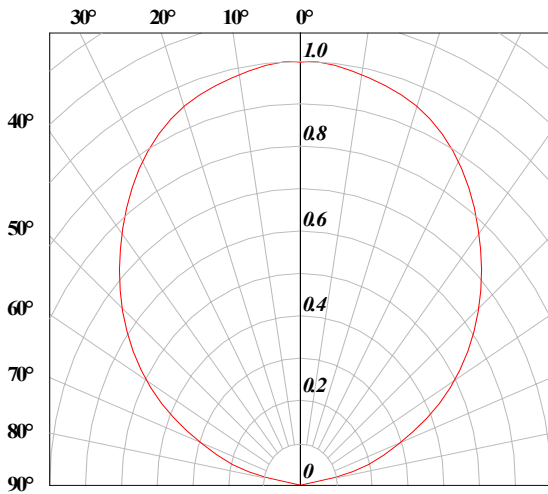

Relative Forward Voltage Vs Junction Temperature
 $\Delta V_F = V_F - V_F(25^\circ\text{C}) = f(T_j)$; $I_F = 20\text{mA}$

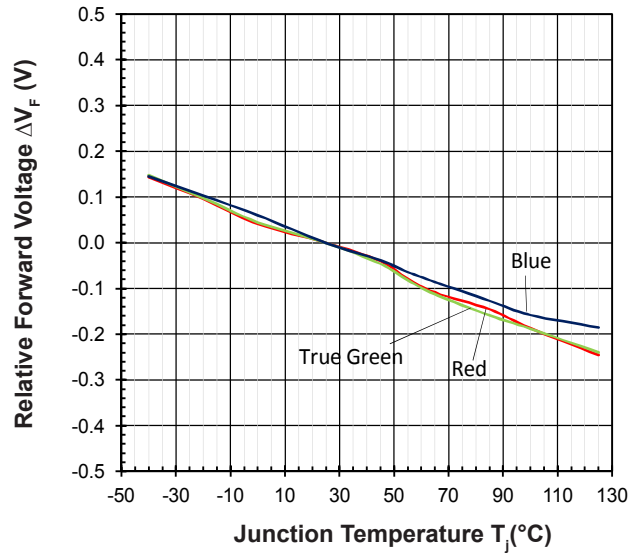

Relative Luminous Intensity Vs Junction Temperature
 $I_v/I_v(25^\circ\text{C}) = f(T_j)$; $I_F = 20\text{mA}$

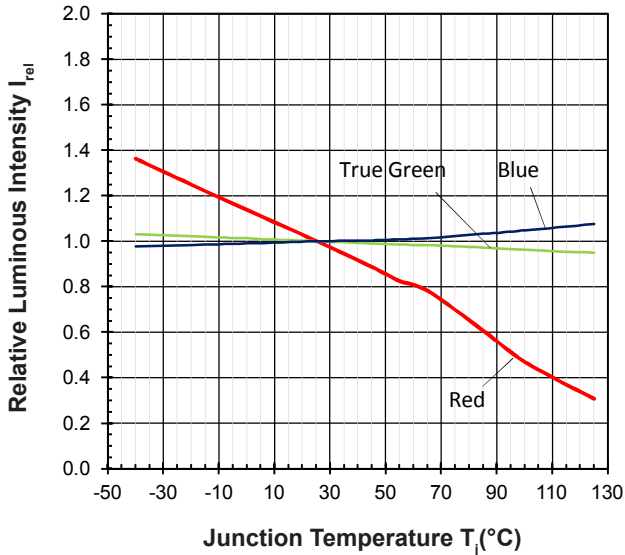

Relative Wavelength Vs Junction Temperature
 $\Delta\lambda_{\text{dom}} = \lambda_{\text{dom}} - \lambda_{\text{dom}}(25^\circ\text{C}) = f(T_j)$; $I_F = 20\text{mA}$

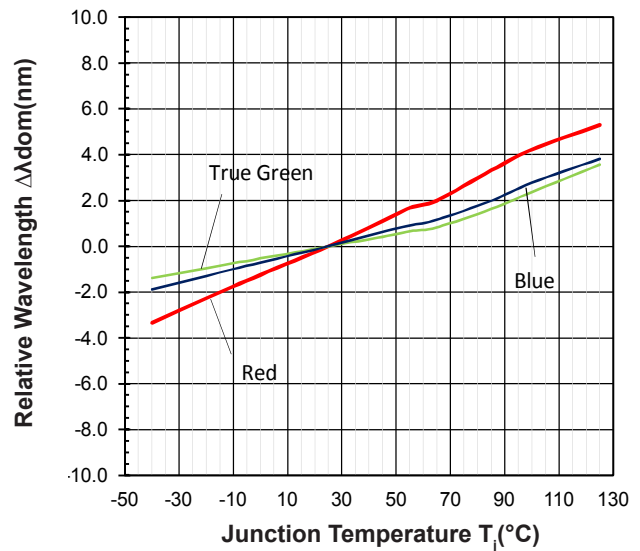

Multi DomiLED : D6RTB-FJG Package Outlines

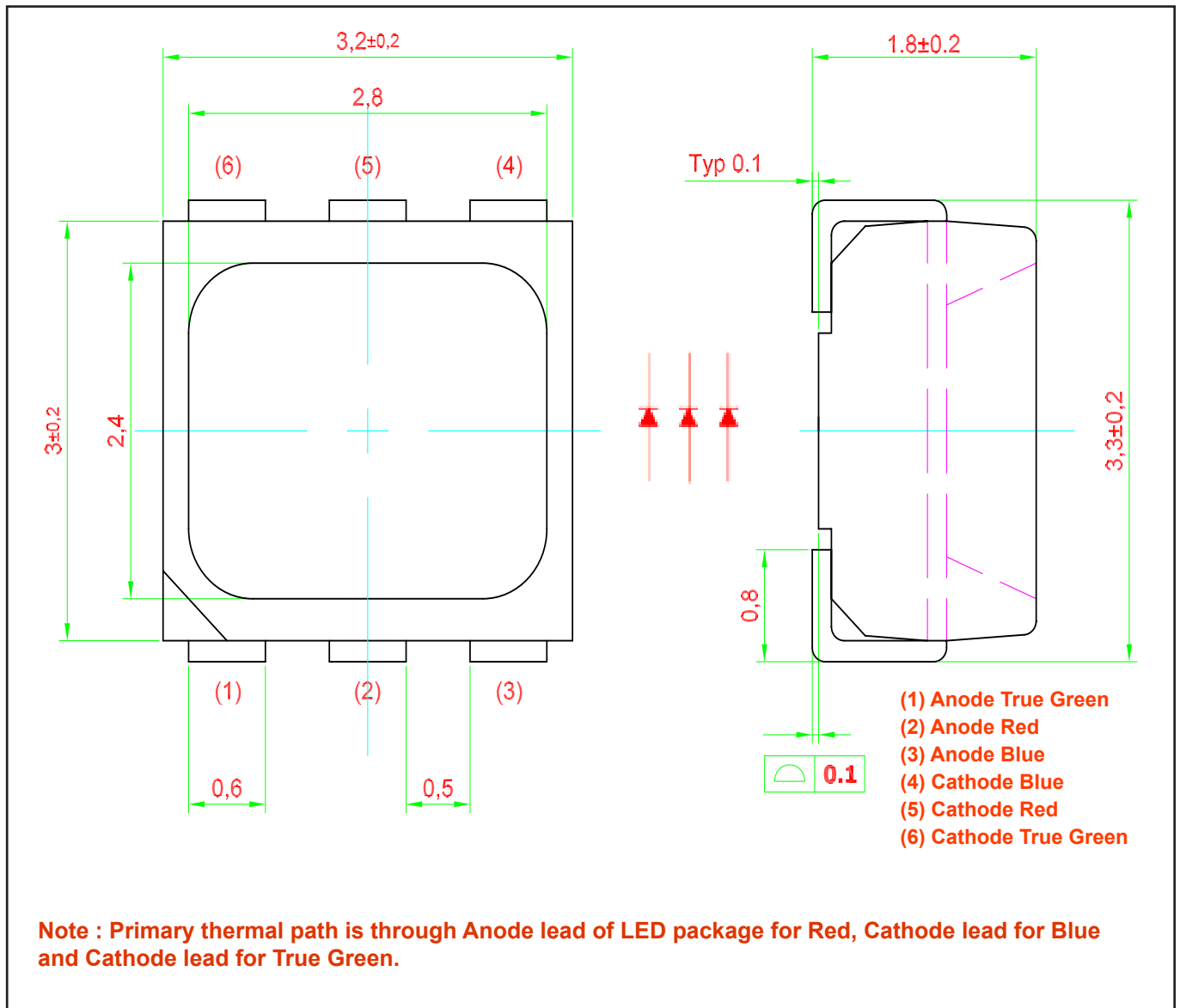

Materials

Materials	
Lead Frame	Copper alloy
Housing	High temperature resistant plastic, PPA
Encapsulant	Silicone resin
Lead-finishing	Pure tin plating, Sn

Note: Package is Pb-free.

Recommended Solder Pad

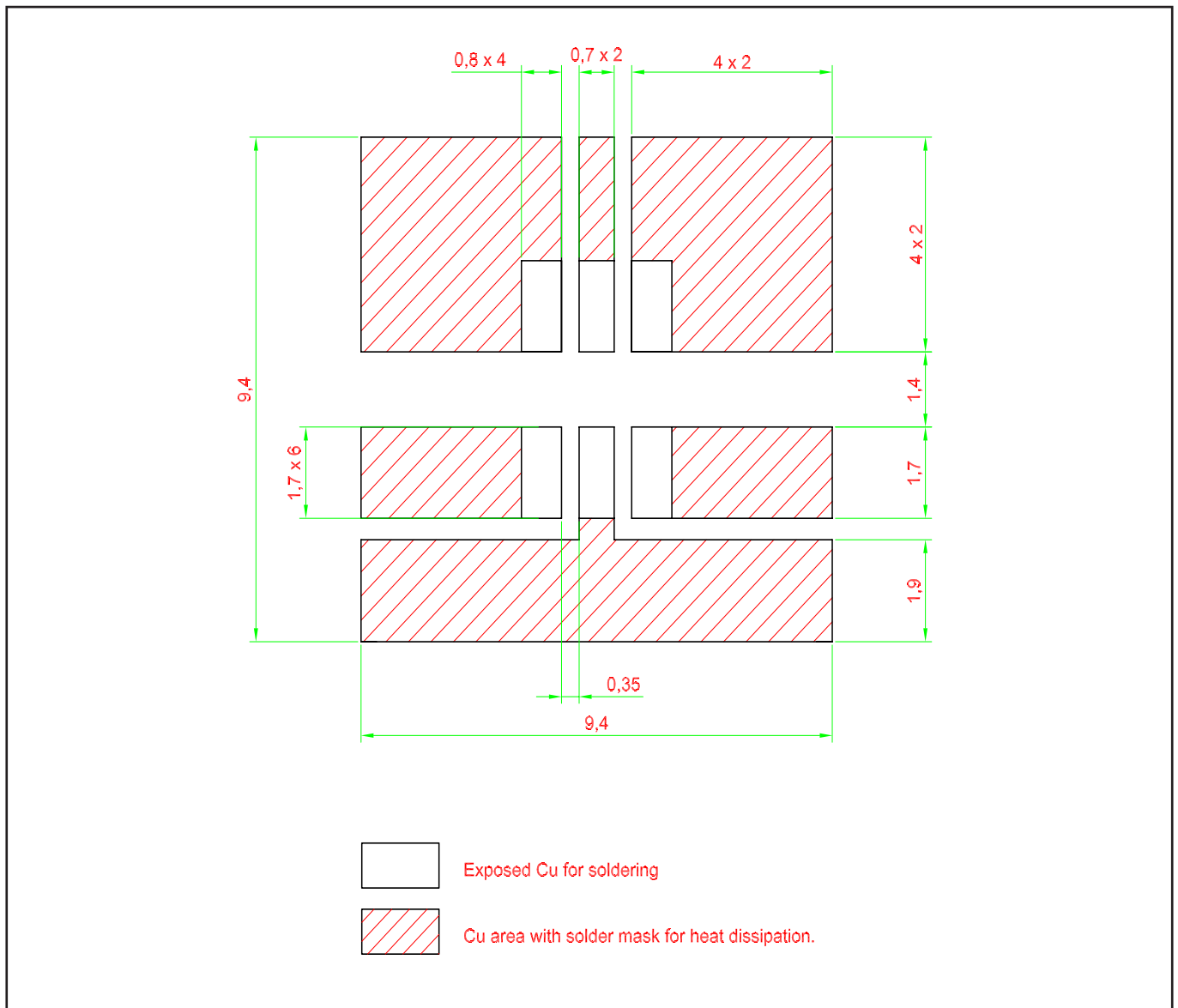

Taping and orientation

- Reels come in quantity of 1000 units.
- Reel diameter is 180 mm.

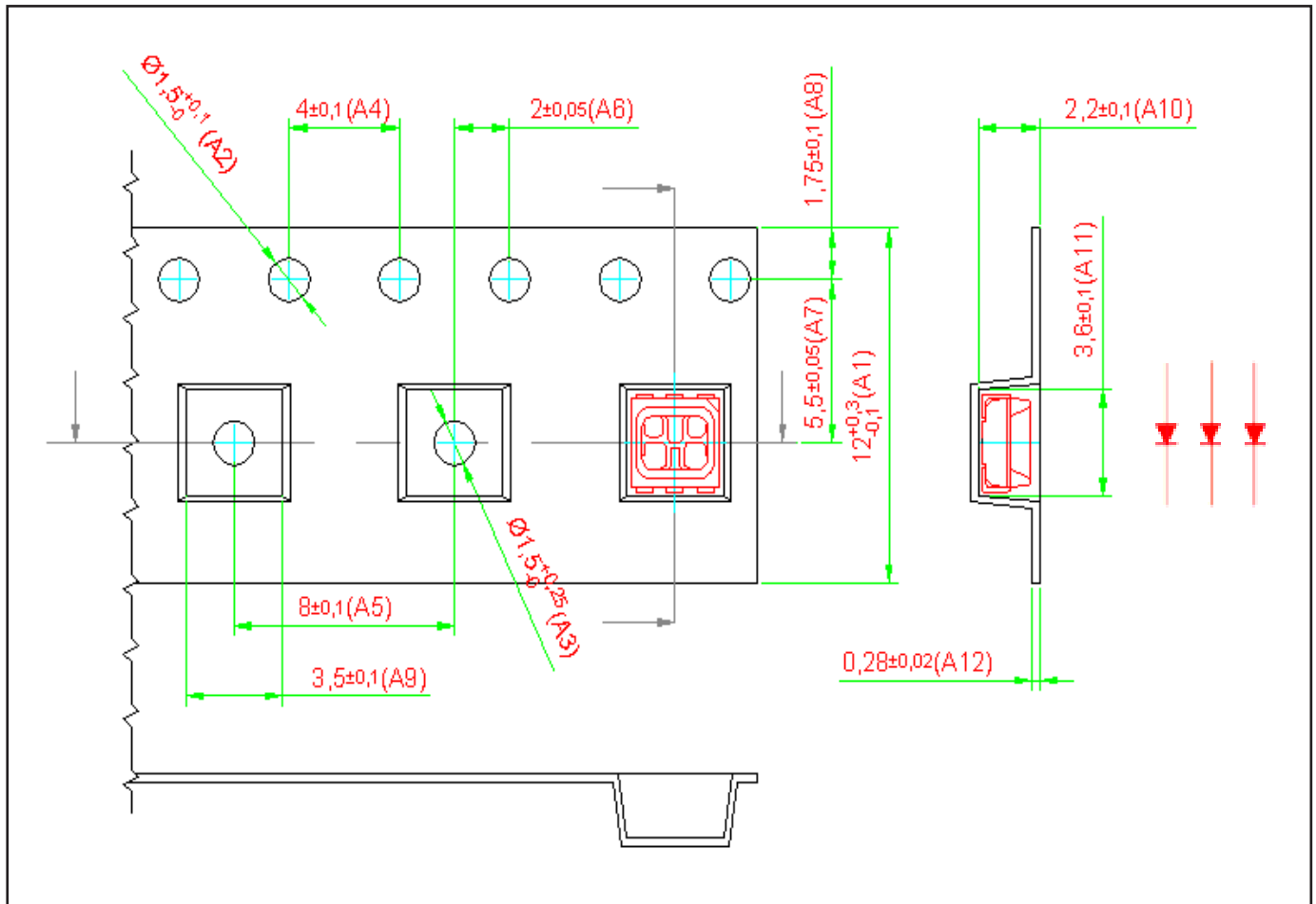

Packaging Specification

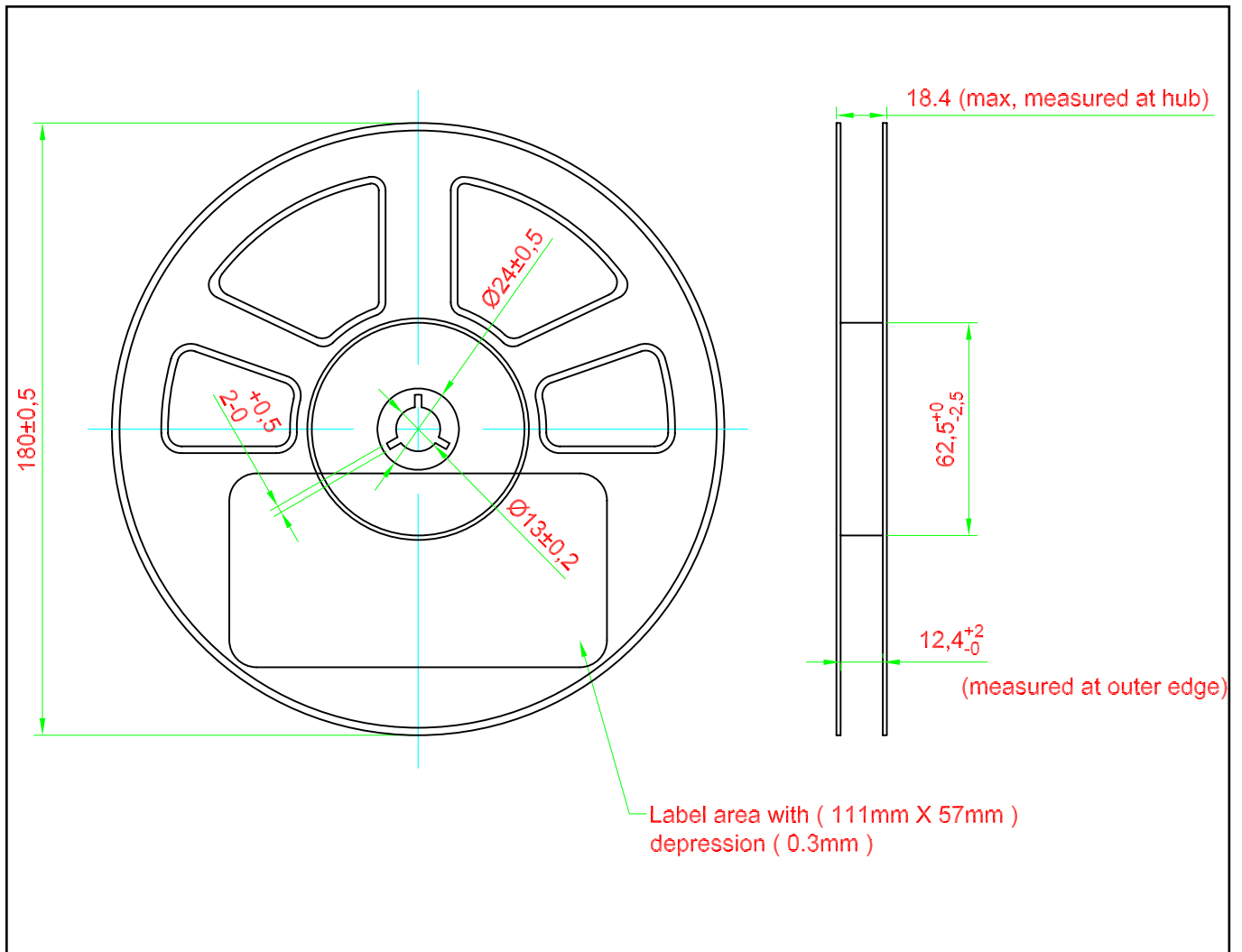

Packaging Specification

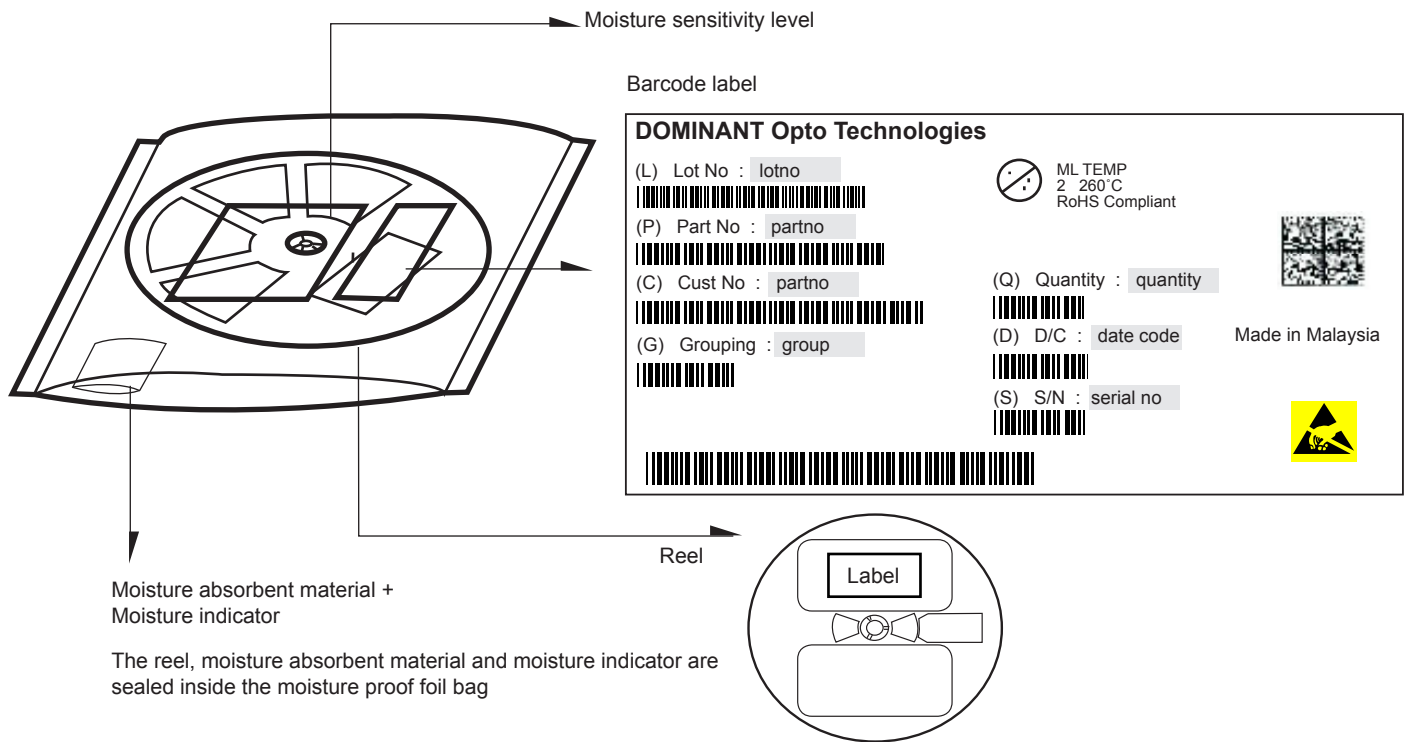

	Average 1pc Multi DomiLED	1 completed bag (1000pcs)
Weight (gram)	0.034	240 ± 10

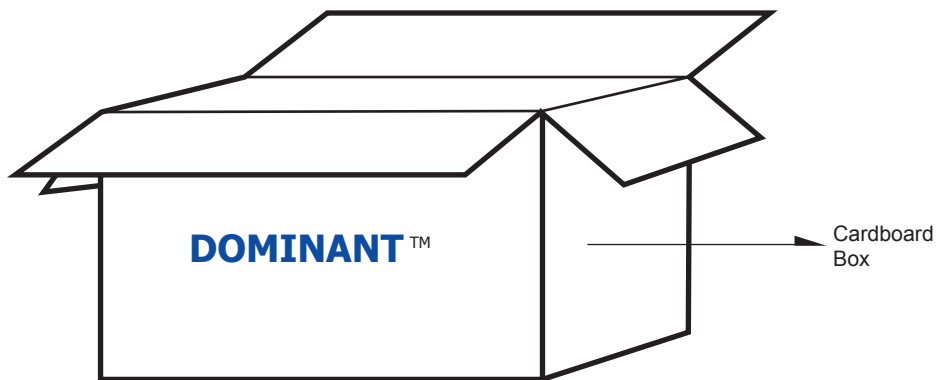

For Multi DomiLED

Cardboard Box Size	Dimensions (mm)	Empty Box Weight (kg)	Reel / Box
Super Small	325 x 225 x 190	0.38	7 reels MAX
Small	325 x 225 x 280	0.54	11 reels MAX
Medium	570 x 440 x 230	1.46	48 reels MAX
Large	570 x 440 x 460	1.92	96 reels MAX

Recommended Pb-free Soldering Profile

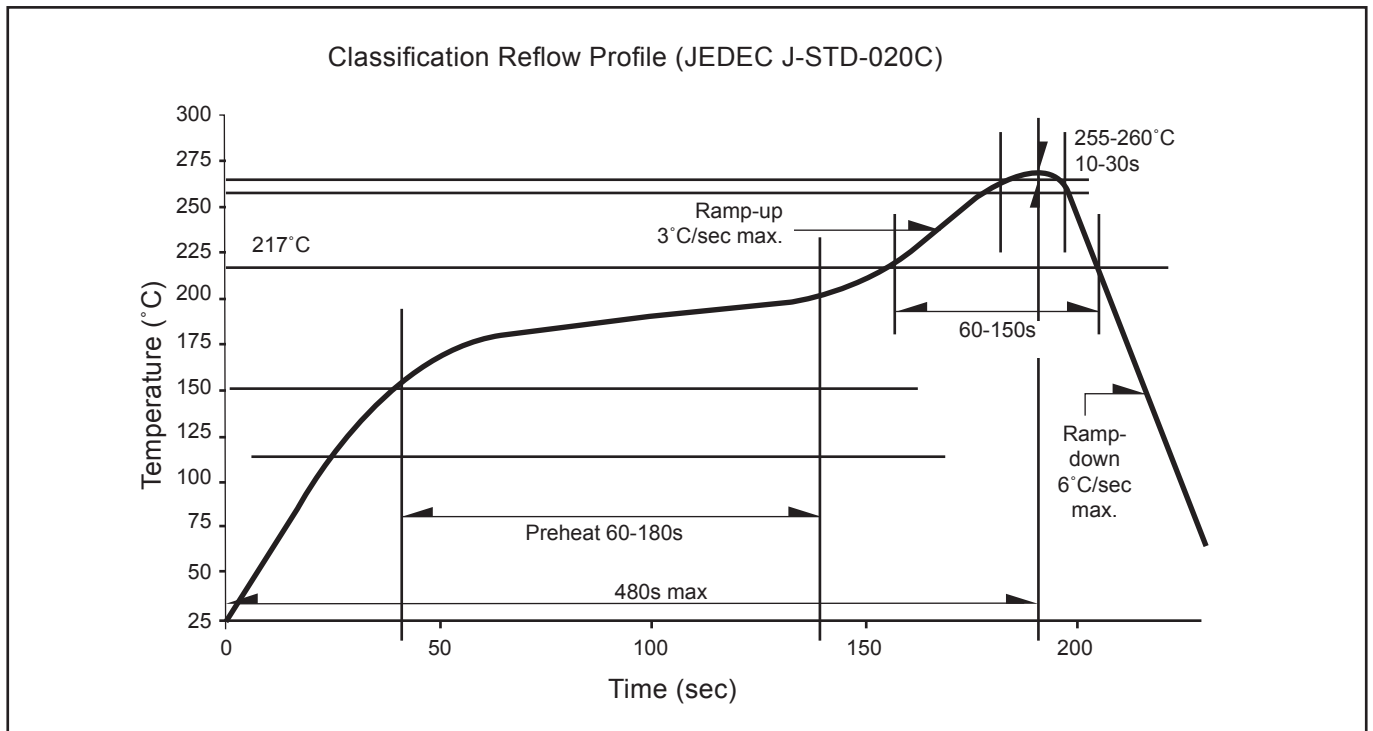

Appendix

1) **Brightness:**

- 1.1 Luminous intensity is measured at current pulse 25 ms(typ) with an internal reproducibility of $\pm 8\%$ and an expanded uncertainty of $\pm 11\%$ (according to GUM with a coverage factor of $k=3$).
- 1.2 Luminous flux is measured at current pulse 25 ms(typ) with an internal reproducibility of $\pm 8\%$ and an expanded uncertainty of $\pm 11\%$ (according to GUM with a coverage factor of $k=3$).
- 1.3 Radiant intensity is measured at current pulse 25 ms(typ) with an internal reproducibility of $\pm 8\%$ and an expanded uncertainty of $\pm 11\%$ (according to GUM with a coverage factor of $k=3$).
- 1.4 Radiant flux is measured at current pulse 25 ms(typ) with an internal reproducibility of $\pm 8\%$ and an expanded uncertainty of $\pm 11\%$ (according to GUM with a coverage factor of $k=3$).

2) **Color:**

- 2.1 Chromaticity coordinate groups are measured at current pulse 25 ms(typ) with an internal reproducibility of ± 0.005 and an expanded uncertainty of ± 0.01 (accordingly to GUM with a coverage factor of $k=3$).
- 2.2 Dominant wavelength is measured at current pulse 25 ms(typ) with an internal reproducibility of $\pm 0.5\text{nm}$ and an expanded uncertainty of $\pm 1\text{nm}$ (accordingly to GUM with a coverage factor of $k=3$).

3) **Voltage:**

- 3.1 Forward Voltage, V_f is measured when a current pulse of 8 ms(typ) with an internal reproducibility of $\pm 0.05\text{V}$ and an expanded uncertainty of $\pm 0.1\text{V}$ (accordingly to GUM with a coverage factor of $k=3$).

4) **Typical Values:**

- 4.1 At special conditions of LED manufacturing processes, typical data or calculated correlations of technical parameters only reflect the statistical figures. But not necessarily correspond to the actual parameters of each single product, which could differ from the typical data or calculated correlations or the typical characteristic line. These typical data may change whenever technical improvements happen.

5) **Tolerance of Measure**

- 5.1 Unless otherwise noted in drawing, tolerances are specified with ± 0.1 and dimension are specific in mm.

6) **Corrosion Robustness:**

- 6.1 Test conditions: 40 °C / 90 % rh / 15 ppm H_2S / 336 h.
= Stricter than IEC 60068-2-43 (H_2S) [25 °C / 75% rh / 10 ppm H_2S / 21 days].

7) **Reverse Voltage:**

- 7.1 Not designed for reverse operation. Continuous reverse voltage can cause migration and LED damage.

Revision History

Page	Subjects	Date of Modification
-	Initial release	30 Oct 2014
1, 3	Add Features and Application Add Characteristics	16 Apr 2015
7, 9, 11	Update Packaging Outline Update Carrier Tape Update Packaging Specification	15 Mar 2016
1, 2, 5, 6, 8, 9, 13	Update Features Update Operating Temperature and Storage Temperature Update Graph Update Recommended Solder Pad Update Taping and Orientation Add Appendix	07 Dec 2016
2, 13	Not For New Design: D6RTB-FJG-W3X3+S2T-1 Update Appendix	16 Mar 2018

NOTE

All the information contained in this document is considered to be reliable at the time of publishing. However, DOMINANT Opto Technologies does not assume any liability arising out of the application or use of any product described herein.

DOMINANT Opto Technologies reserves the right to make changes to any products in order to improve reliability, function or design.

DOMINANT Opto Technologies products are not authorized for use as critical components in life support devices or systems without the express written approval from the Managing Director of DOMINANT Opto Technologies.

About Us

DOMINANT Opto Technologies is a dynamic company that is amongst the world's leading automotive LED manufacturers. With an extensive industry experience and relentless pursuit of innovation, DOMINANT's state-of-art manufacturing and development capabilities have become a trusted and reliable brand across the globe. More information about DOMINANT Opto Technologies, a ISO/TS 16949 and ISO 14001 certified company, can be found under <http://www.dominant-semi.com>.

Please contact us for more information:

DOMINANT Opto Technologies Sdn. Bhd.
Lot 6, Batu Berendam, FTZ Phase III, 75350 Melaka, Malaysia
Tel: (606) 283 3566 Fax: (606) 283 0566
E-mail: sales@dominant-semi.com