

## Silicon NPN Power Transistors

## 2SD762 2SD762A

## DESCRIPTION

www.datasheet4u.com

- With TO-220C package
- Wide area of safe operation

## APPLICATIONS

- For audio frequency power amplifier applications

## PINNING

PIN	DESCRIPTION
1	Base
2	Collector;connected to mounting base
3	Emitter

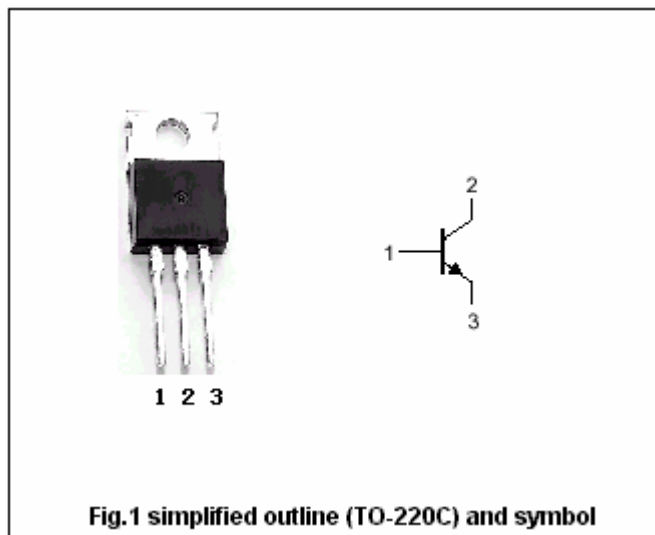

Fig.1 simplified outline (TO-220C) and symbol

Absolute maximum ratings( $T_c=25^\circ\text{C}$ )

SYMBOL	PARAMETER	CONDITIONS	VALUE	UNIT
$V_{CBO}$	Collector-base voltage	2SD762	60	V
		2SD762A	80	
$V_{CEO}$	Collector-emitter voltage	2SD762	60	V
		2SD762A	80	
$V_{EBO}$	Emitter-base voltage	Open collector	8	V
$I_C$	Collector current		4	A
$I_{CM}$	Collector current-peak		6	A
$I_B$	Base current		1	A
$P_C$	Collector power dissipation	$T_c=25^\circ\text{C}$	30	W
$T_j$	Junction temperature		150	$^\circ\text{C}$
$T_{stg}$	Storage temperature		-55~150	$^\circ\text{C}$

## Silicon NPN Power Transistors

## 2SD762 2SD762A

## CHARACTERISTICS

T<sub>j</sub>=25°C unless otherwise specified

www.datasheet4u.com

SYMBOL	PARAMETER	CONDITIONS	MIN	TYP.	MAX	UNIT	
V <sub>CEO(SUS)</sub>	Collector-emitter sustaining voltage	2SD762	I <sub>C</sub> =0.2A; L=25mH	60			V
		2SD762A		80			
V <sub>CEsat</sub>	Collector-emitter saturation voltage	I <sub>C</sub> =2 A; I <sub>B</sub> =0.4 A			1.0	V	
V <sub>BE</sub>	Base-emitter on voltage	I <sub>C</sub> =1A ; V <sub>CE</sub> =3V			1.2	V	
I <sub>CBO</sub>	Collector cut-off current	V <sub>CB</sub> =50V; I <sub>E</sub> =0			30	μA	
I <sub>EBO</sub>	Emitter cut-off current	V <sub>EB</sub> =8V; I <sub>C</sub> =0			1	mA	
h <sub>FE-1</sub>	DC current gain	I <sub>C</sub> =0.1A ; V <sub>CE</sub> =3V	40				
h <sub>FE-2</sub>	DC current gain	I <sub>C</sub> =1A ; V <sub>CE</sub> =3V	30		160		

◆ h<sub>FE-2</sub> classifications

Q	P	O
30-60	50-100	80-160

Silicon NPN Power Transistors

2SD762 2SD762A

PACKAGE OUTLINE

www.datasheet4u.com

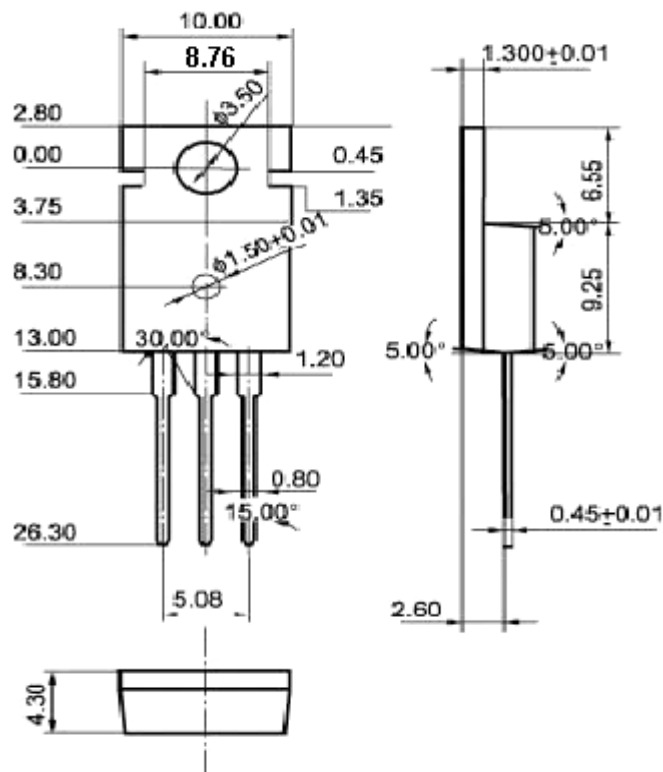

Fig.2 Outline dimensions (unindicated tolerance:  $\pm 0.10$  mm)