

www.DataSheet4U.com

μ PD78064, 78064Y Subseries

8-Bit Single-Chip Microcontrollers

μ PD78062

μ PD78062Y

μ PD78063

μ PD78063Y

μ PD78064

μ PD78064Y

μ PD78P064

μ PD78P064Y

[MEMO]

www.DataSheet4U.com

NOTES FOR CMOS DEVICES

① PRECAUTION AGAINST ESD FOR SEMICONDUCTORS

Note:

Strong electric field, when exposed to a MOS device, can cause destruction of the gate oxide and ultimately degrade the device operation. Steps must be taken to stop generation of static electricity as much as possible, and quickly dissipate it once, when it has occurred. Environmental control must be adequate. When it is dry, humidifier should be used. It is recommended to avoid using insulators that easily build static electricity. Semiconductor devices must be stored and transported in an anti-static container, static shielding bag or conductive material. All test and measurement tools including work bench and floor should be grounded. The operator should be grounded using wrist strap. Semiconductor devices must not be touched with bare hands. Similar precautions need to be taken for PW boards with semiconductor devices on it.

② HANDLING OF UNUSED INPUT PINS FOR CMOS

Note:

No connection for CMOS device inputs can be cause of malfunction. If no connection is provided to the input pins, it is possible that an internal input level may be generated due to noise, etc., hence causing malfunction. CMOS devices behave differently than Bipolar or NMOS devices. Input levels of CMOS devices must be fixed high or low by using a pull-up or pull-down circuitry. Each unused pin should be connected to V_{DD} or GND with a resistor, if it is considered to have a possibility of being an output pin. All handling related to the unused pins must be judged device by device and related specifications governing the devices.

③ STATUS BEFORE INITIALIZATION OF MOS DEVICES

Note:

Power-on does not necessarily define initial status of MOS device. Production process of MOS does not define the initial operation status of the device. Immediately after the power source is turned ON, the devices with reset function have not yet been initialized. Hence, power-on does not guarantee out-pin levels, I/O settings or contents of registers. Device is not initialized until the reset signal is received. Reset operation must be executed immediately after power-on for devices having reset function.

FIP is a trademark of NEC Corporation.

IEBus, QTOP are trademarks of NEC Corporation.

MS-DOS and Windows are trademarks of Microsoft Corporation.

IBM DOS, PC/AT and PC DOS are trademarks of IBM Corporation.

HP9000 Series 300, HP9000 Series 700, and HP-UX are trademarks of Hewlett-Packard Company.

SPARCstation is a trademark of SPARC International, Inc.

SunOS is a trademark of Sun Microsystems, Inc.

TRON is an abbreviation of The Realtime Operating system Nucleus.

ITRON is an abbreviation of Industrial TRON.

The export of these products from Japan is regulated by the Japanese government. The export of some or all of these products may be prohibited without governmental license. To export or re-export some or all of these products from a country other than Japan may also be prohibited without a license from that country. Please call an NEC sales representative.

License not needed: μ PD78P064KL-T, 78P064YKL-T

The customer must judge the need for license:

μ PD78062GC- x x x -7EA, 78062YGC- x x x -7EA,

μ PD78062GF- x x x -3BA, 78062YGF- x x x -3BA,

μ PD78063GC- x x x -7EA, 78063YGC- x x x -7EA,

μ PD78063GF- x x x -3BA, 78063YGF- x x x -3BA,

μ PD78064GC- x x x -7EA, 78064YGC- x x x -7EA,

μ PD78064GF- x x x -3BA, 78064YGF- x x x -3BA,

μ PD78P064GC-7EA, 78P064YGC-7EA,

μ PD78P064GF-3BA, 78P064YGF-3BA

The application circuits and their parameters are for references only and are not intended for use in actual design-in's.

Purchase of NEC I²C components conveys a license under the Philips I²C Patent Rights to use these components in an I²C system, provided that the system conforms to the I²C Standard Specification as defined by Philips.

- **The information in this document is subject to change without notice. Before using this document, please confirm that this is the latest version.**
 - **Not all devices/types available in every country. Please check with local NEC representative for availability and additional information.**
 - No part of this document may be copied or reproduced in any form or by any means without the prior written consent of NEC Corporation. NEC Corporation assumes no responsibility for any errors which may appear in this document.
 - NEC Corporation does not assume any liability for infringement of patents, copyrights or other intellectual property rights of third parties by or arising from use of a device described herein or any other liability arising from use of such device. No license, either express, implied or otherwise, is granted under any patents, copyrights or other intellectual property rights of NEC Corporation or others.
 - Descriptions of circuits, software, and other related information in this document are provided for illustrative purposes in semiconductor product operation and application examples. The incorporation of these circuits, software, and information in the design of the customer's equipment shall be done under the full responsibility of the customer. NEC Corporation assumes no responsibility for any losses incurred by the customer or third parties arising from the use of these circuits, software, and information.
 - While NEC Corporation has been making continuous effort to enhance the reliability of its semiconductor devices, the possibility of defects cannot be eliminated entirely. To minimize risks of damage or injury to persons or property arising from a defect in an NEC semiconductor device, customers must incorporate sufficient safety measures in its design, such as redundancy, fire-containment, and anti-failure features.
 - NEC devices are classified into the following three quality grades:
"Standard", "Special", and "Specific". The Specific quality grade applies only to devices developed based on a customer designated "quality assurance program" for a specific application. The recommended applications of a device depend on its quality grade, as indicated below. Customers must check the quality grade of each device before using it in a particular application.
 - Standard: Computers, office equipment, communications equipment, test and measurement equipment, audio and visual equipment, home electronic appliances, machine tools, personal electronic equipment and industrial robots
 - Special: Transportation equipment (automobiles, trains, ships, etc.), traffic control systems, anti-disaster systems, anti-crime systems, safety equipment and medical equipment (not specifically designed for life support)
 - Specific: Aircraft, aerospace equipment, submersible repeaters, nuclear reactor control systems, life support systems or medical equipment for life support, etc.
- The quality grade of NEC devices is "Standard" unless otherwise specified in NEC's Data Sheets or Data Books. If customers intend to use NEC devices for applications other than those specified for Standard quality grade, they should contact an NEC sales representative in advance.

M7D 98.12

Regional Information

Some information contained in this document may vary from country to country. Before using any NEC product in your application, please contact the NEC office in your country to obtain a list of authorized representatives and distributors. They will verify:

- Device availability
- Ordering information
- Product release schedule
- Availability of related technical literature
- Development environment specifications (for example, specifications for third-party tools and components, host computers, power plugs, AC supply voltages, and so forth)
- Network requirements

In addition, trademarks, registered trademarks, export restrictions, and other legal issues may also vary from country to country.

NEC Electronics Inc. (U.S.)

Santa Clara, California
Tel: 408-588-6000
800-366-9782
Fax: 408-588-6130
800-729-9288

NEC Electronics (Germany) GmbH

Duesseldorf, Germany
Tel: 0211-65 03 02
Fax: 0211-65 03 490

NEC Electronics (UK) Ltd.

Milton Keynes, UK
Tel: 01908-691-133
Fax: 01908-670-290

NEC Electronics Italiana s.r.l.

Milano, Italy
Tel: 02-66 75 41
Fax: 02-66 75 42 99

NEC Electronics (Germany) GmbH

Benelux Office
Eindhoven, The Netherlands
Tel: 040-2445845
Fax: 040-2444580

NEC Electronics (France) S.A.

Velizy-Villacoublay, France
Tel: 01-30-67 58 00
Fax: 01-30-67 58 99

NEC Electronics (France) S.A.

Spain Office
Madrid, Spain
Tel: 91-504-2787
Fax: 91-504-2860

NEC Electronics (Germany) GmbH

Scandinavia Office
Taebby, Sweden
Tel: 08-63 80 820
Fax: 08-63 80 388

NEC Electronics Hong Kong Ltd.

Hong Kong
Tel: 2886-9318
Fax: 2886-9022/9044

NEC Electronics Hong Kong Ltd.

Seoul Branch
Seoul, Korea
Tel: 02-528-0303
Fax: 02-528-4411

NEC Electronics Singapore Pte. Ltd.

United Square, Singapore 1130
Tel: 65-253-8311
Fax: 65-250-3583

NEC Electronics Taiwan Ltd.

Taipei, Taiwan
Tel: 02-2719-2377
Fax: 02-2719-5951

NEC do Brasil S.A.

Electron Devices Division
Rodovia Presidente Dutra, Km 214
07210-902-Guarulhos-SP Brasil
Tel: 55-11-6465-6810
Fax: 55-11-6465-6829

J99.1

Major Revised Points

(1/2)

Page	Revisions
Throughout	μPD78064Y subseries has been added for target devices.
p.8	Section 1.5 "78K/0 Series Expansion" has been modified.
p.36	Table 3-1. "Pin Input/Output Circuit Types" has been modified. <ul style="list-style-type: none"> • Recommended connections of the following unused pins P07/XT1, P110 to P117, V_{PP} • Input/output circuit type of the following pins P110 to P117
p.108	PM2 given in Figure 6-17. "Port Mode Register Format" has been modified.
p.117	A caution given in Figure 7-4. "Oscillation Mode Selection Register Format" has been modified and added.
p.118	A caution given in Figure 7-6. "External Circuit of Main System Clock Oscillator" has been modified.
p.121	Section 7.4.4 "When no subsystem clocks are used" has been modified. Connection of XT1 pin: Connect to V _{SS} -> Connect to V _{DD} .
p.197	Figure 10-1. "Watch Timer Block Diagram" has been modified.
p.223	Figure 14-2. "A/D Converter Mode Register Format" has been modified.
p.233	Section 14.5(7) "AV _{DD} pin" has been modified and Figure 14-12. "Handling of AV _{DD} Pin" has been added.
p.244	Figure 15-4. "Serial Operating Mode Register 0 Format" has been modified.
p.261	Figure 15-18. "Acknowledge Signal" has been modified.
p.267	Figure 15-21. "RELD and CMDD Operations (Slave)" has been modified.
p.284	Section 15.4.4(c) "Interrupt timing specify register (SINT)" has been modified.
p.287	Figure 15-34. " $\overline{\text{SCK0}}$ /P27 Pin Configuration" has been modified.
p.339	Figure 17-1. "Serial Interface Channel 2 Block Diagram" has been modified.
p.348	Range of baud rate transmit/receive clock generated by main system clock has been changed. 75 bps to 38400 bps -> 75 bps to 76800 bps
p.429	Table 20-1. "HALT Mode Operating Status" has been modified. Description of HALT mode operating status has been separated to those during main system clock execution and during sub-system clock execution.
p.432	Cautions given in Section 20.2.2(1) "STOP Mode Set and Operating Status" have been modified.
p.432	Table 20-3. "STOP Mode Operating Status" has been modified. Description of STOP mode operating status has been separated to those during main system clock execution and during sub-system clock execution.

Page	Revisions
p.448	Description of QTOP microcontroller has been added to Section 22.5 "Screening of One-Time PROM Versions".
p.465, 475	HP9000 series 700 has been added for the host machine of development tools and embedded software.
p.469	System simulator (SM78K0) has been added for development tools.
p.470	Section A.4 "Operating System for IBM PC" has been added.
p.476	OS(MX78K0) has been added for embedded software.

The asterisks on page margins show revised points.

PREFACE

Readers

This manual has been prepared for user engineers who want to understand the functions of the μ PD78064 and 78064Y subseries and design and develop its application systems and programs.

- μ PD78064 subseries : μ PD78062, 78063, 78064, 78P064
- μ PD78064Y subseries : μ PD78062Y, 78063Y, 78064Y, 78P064Y **Note**

Note Under development

www.DataSheet4U.com Purpose

This manual is intended for users to understand the functions described in the Organization below.

Organization

The μ PD78064, 78064Y subseries manual is separated into two parts: this manual and the instruction edition (common to the 78K/0 series).

μ PD78064, 78064Y
subseries
User's Manual

- Pin functions
- Internal block functions
- Interrupt

78K/0 series
User's Manual
Instruction

- CPU functions
 - Instruction set
 - Explanation of each instruction
- Other on-chip peripheral functions

How to Read This Manual

Before reading this manual, you should have general knowledge of electric and logic circuits and microcontrollers.

- When you want to understand the functions in general:
 - Read this manual in the order of the contents.
- How to interpret the register format:
 - For the circled bit number, the bit name is defined as a reserved word in RA78K/0, and in CC78K/0, already defined in the header file named sfrbit.h.
- When you know a register name and want to confirm its details:
 - Read **APPENDIX C REGISTER INDEX**.
- To know the μ PD78064 and 78064Y subseries instruction function in detail:
 - Refer to the **78K/0 series User's Manual: Instructions (IEU-1372)**
- To know the electrical specifications of the μ PD78064 and 78064Y subseries:
 - Refer to separately available **Data Sheet μ PD78062, 78063 and 78064 (IC-3244), μ PD78P064 Data Sheet (IC-3224), μ PD78062Y, 78063Y, 78064Y Data Sheet (IC-3235)**
- To know the application example of each function of the μ PD78064 and 78064Y subseries:
 - Refer to separately available **Application Note 78K/0 Series: Basic (III) (In preparation), 78K/0 series Application Note: Floating-Point Operation Program (IEA-1289)**

Chapter Organization: This manual divides the descriptions for the μ PD78064 and 78064Y subseries into different chapters as shown below. Read only the chapters related to the device you use.

Chapter	μ PD78064 Subseries	μ PD78064Y Subseries
Chapter 1 Outline (μ PD78064 Subseries)	√	—
Chapter 2 Outline (μ PD78064Y Subseries)	—	√
Chapter 3 Pin Function (μ PD78064 Subseries)	√	—
Chapter 4 Pin Function (μ PD78064Y Subseries)	—	√
Chapter 5 CPU Architecture	√	√
Chapter 6 Port Functions	√	√
Chapter 7 Clock Generator	√	√
Chapter 8 16-Bit Timer/Event Counter	√	√
Chapter 9 8-Bit Timer/Event Counters 1 and 2	√	√
Chapter 10 Watch Timer	√	√
Chapter 11 Watchdog Timer	√	√
Chapter 12 Clock Output Control Circuit	√	√
Chapter 13 Buzzer Output Control Circuit	√	√
Chapter 14 A/D Converter	√	√
Chapter 15 Serial Interface Channel 0 (μ PD78064 Subseries)	√	—
Chapter 16 Serial Interface Channel 0 (μ PD78064Y Subseries)	—	√
Chapter 17 Serial Interface Channel 2	√	√
Chapter 18 LCD Controller / Driver	√	√
Chapter 19 Interrupt and Test Functions	√	√
Chapter 20 Standby Function	√	√
Chapter 21 Reset Function	√	√
Chapter 22 μ PD78P064, μ PD78P064Y	√	√
Chapter 23 Instruction Set	√	√

Differences between μ PD78064 and μ PD78064Y subseries:

The μ PD78064 and μ PD78064Y subseries are different in the following functions of the serial interface channel 0.

Modes of serial interface channel 0	μ PD78064 Subseries	μ PD78064Y Subseries
3-wire serial I/O mode	√	√
2-wire serial I/O mode	√	√
SBI (serial bus interface) mode	√	—
I ² C (Inter IC) bus mode	—	√

√ : Supported

— : Not supported

www.DataSheet4U.com

Legend

Data representation weight	: High digits on the left and low digits on the right
Active low representations	: $\overline{\text{xxx}}$ (line over the pin and signal names)
Note	: Description of note in the text.
Caution	: Information requiring particular attention
Remarks	: Additional explanatory material
Numeral representations	: Binary ... xxxx or xxxxB Decimal ... xxxx Hexadecimal ... xxxxH

Related Documents

The related documents indicated in this publication may include preliminary versions. However, preliminary versions are not marked as such.

● Related documents for μ PD78064 subseries

Document name	Document No.		
	English	Japanese	
μ PD78062, 78063, 78064 Data Sheet	U12338E	U12338J	
μ PD78P064 Data Sheet	U12589E	U12589J	
μ PD78064, 78064Y Subseries User's Manual	This manual	U10105J	
78K/0 Series User's Manual—Instruction	U12326E	U12326J	
μ PD78064, 78064B Subseries Special Function Register Table	—	U12696J	
78K/0 Series Application Note	Basics III	U10182E	U10182J
	Floating-point operation program	IEA-1289	U13482J

● Related documents for μ PD78064Y subseries

Document name	Document No.		
	English	Japanese	
μ PD78062Y, 78063Y, 78064Y Data Sheet	U10337E	U10337J	
μ PD78P064Y Preliminary Product Information	IP-3236	U10321J	
μ PD78064, 78064Y Subseries User's Manual	This manual	U10105J	
78K/0 Series User's Manual—Instruction	U12326E	U12326J	
μ PD78064Y Subseries Special Function Register Table	—	IEM-5583	
78K/0 Series Application Note	Basics III	U10182E	U10182J
	Floating-point operation program	IEA-1289	U13482J

Caution The above documents are subject to change without prior notice. Be sure to use the latest version document when starting design.

● **Development Tool Documents (User's Manuals)**

Document Name		Document No.	
		English	Japanese
RA78K0 Assembler Package	Operation	U11802E	U11802J
	Language	U11801E	U11801J
	Structured Assembly Language	U11789E	U11789J
RA78K Series Structured Assembler Preprocessor		EEU-1402	U12323J
CC78K0 C Compiler	Operation	U11517E	U11517J
	Language	U11518E	U11518J
PG-1500 PROM Programmer		U11940E	U11940J
PG-1500 Controller PC-9800 Series (MS-DOS™) Base		EEU-1291	EEU-704
PG-1500 Controller IBM PC Series (PC DOS™) Base		U10540E	EEU-5008
IE-78000-R		U11376E	U11376J
IE-78000-R-BK		EEU-1427	EEU-867
IE-78064-R-EM		EEU-1443	EEU-905
EP-78064		EEU-1469	EEU-934
SM78K0 System Simulator — Windows based	Reference	U10181E	U10181J
SM78K Series System Simulator	External Part User Open Interface Specifications	U10092E	U10092J
ID78K0-NS Integrated Debugger, Windows based	Reference	—	U12900J
ID78K0 Integrated Debugger, EWS based	Reference	—	U11151J
ID78K0 Integrated Debugger, Windows based	Guide	U11649E	U11649J
ID78K0 Integrated Debugger, PC based	Reference	U11539E	U11539J

Caution The above documents are subject to change without prior notice. Be sure to use the latest version document when starting design.

● Documents for Embedded Software (User's Manual)

Document Name		Document No.	
		English	Japanese
78K/0 Series Real-Time OS	Fundamentals	U11537E	U11537J
	Installation	U11536E	U11536J
78K/0 Series OS MX78K0	Fundamental	U12257E	U12257J

● Other Documents

Document Name		Document No.	
		English	Japanese
SEMICONDUCTORS SELECTION GUIDE Products & Packages (CD-ROM)		X13769X	
Semiconductor Device Mounting Technology Manual		C10535E	C10535J
Quality Grades on NEC Semiconductor Devices		C11531E	C11531J
NEC Semiconductor Device Reliability/Quality Control System		C10983E	C10983J
Guide to Prevent Damage for Semiconductor Devices by Electrostatic Discharge (ESD)		C11892E	C11892J
Review of Quality and Reliability Handbook		—	C12769J
Guide to Microcomputer-Related Products by Third party		—	U11416J

Caution The above documents are subject to change without prior notice. Be sure to use the latest version document when starting design.

CONTENTS

CHAPTER 1 OUTLINE (μPD78064 Subseries)	1
1.1 Features	1
1.2 Applications	2
1.3 Ordering Information	2
1.4 Pin Configuration (Top View)	3
1.5 78K/0 Series Expansion	8
1.6 Block Diagram	10
1.7 Outline of Function	11
1.8 Mask Options	12
CHAPTER 2 OUTLINE (μPD78064Y Subseries)	13
2.1 Features	13
2.2 Applications	14
2.3 Ordering Information	14
2.4 Pin Configuration (Top View)	15
2.5 78K/0 Series Expansion	20
2.6 Block Diagram	22
2.7 Outline of Function	23
2.8 Mask Options	24
CHAPTER 3 PIN FUNCTION (μPD78064 Subseries)	25
3.1 Pin Function List	25
3.1.1 Normal operating mode pins	25
3.1.2 PROM programming mode pins (μ PD78P064 only)	28
3.2 Description of Pin Functions	29
3.2.1 P00 to P05, P07 (Port 0)	29
3.2.2 P10 to P17 (Port 1)	30
3.2.3 P25 to P27 (Port 2)	30
3.2.4 P30 to P37 (Port 3)	31
3.2.5 P70 to P72 (Port 7)	32
3.2.6 P80 – P87 (Port 8)	33
3.2.7 P90 – P97 (Port 9)	33
3.2.8 P100 – P103 (Port 10)	33
3.2.9 P110 – P117 (Port 11)	33
3.2.10 COM0 to COM3	34
3.2.11 $V_{LC0} - V_{LC2}$	34
3.2.12 BIAS	34
3.2.13 AV_{REF}	34
3.2.14 AV_{DD}	34
3.2.15 AV_{SS}	34
3.2.16 \overline{RESET}	34

3.2.17	X1 and X2	34
3.2.18	XT1 and XT2	34
3.2.19	V _{DD}	35
3.2.20	V _{SS}	35
3.2.21	V _{PP} (μ PD78P064 only)	35
3.2.22	IC (Mask ROM version only)	35

3.3 Input/output Circuits and Recommended Connection of Unused Pins 36

CHAPTER 4 PIN FUNCTION (μ PD78064Y Subseries) 41

4.1 Pin Function List 41

4.1.1	Normal operating mode pins	41
4.1.2	PROM programming mode pins (μ PD78P064Y only)	44

4.2 Description of Pin Functions 45

4.2.1	P00 to P05, P07 (Port 0)	45
4.2.2	P10 to P17 (Port 1)	46
4.2.3	P25 to P27 (Port 2)	46
4.2.4	P30 to P37 (Port 3)	47
4.2.5	P70 to P72 (Port 7)	48
4.2.6	P80 – P87 (Port 8)	49
4.2.7	P90 – P97 (Port 9)	49
4.2.8	P100 – P103 (Port 10)	49
4.2.9	P110 – P117 (Port 11)	49
4.2.10	COM0 to COM3	50
4.2.11	V _{LC0} – V _{LC2}	50
4.2.12	BIAS	50
4.2.13	AV _{REF}	50
4.2.14	AV _{DD}	50
4.2.15	AV _{SS}	50
4.2.16	$\overline{\text{RESET}}$	50
4.2.17	X1 and X2	50
4.2.18	XT1 and XT2	50
4.2.19	V _{DD}	51
4.2.20	V _{SS}	51
4.2.21	V _{PP} (μ PD78P064Y only)	51
4.2.22	IC (Mask ROM version only)	51

4.3 Input/output Circuits and Recommended Connection of Unused Pins 52

CHAPTER 5 CPU ARCHITECTURE 57

5.1 Memory Spaces 57

5.1.1	Internal program memory space	61
5.1.2	Internal data memory space	62
5.1.3	Special Function Register (SFR) area	62
5.1.4	Data memory addressing	63

5.2 Processor Registers 67

5.2.1	Control registers	67
5.2.2	General registers	69
5.2.3	Special Function Register (SFR)	71

5.3	Instruction Address Addressing	75
5.3.1	Relative Addressing	75
5.3.2	Immediate addressing	76
5.3.3	Table indirect addressing	77
5.3.4	Register addressing	78
5.4	Operand Address Addressing	79
5.4.1	Implied addressing	79
5.4.2	Register addressing	80
5.4.3	Direct addressing	81
5.4.4	Short direct addressing	82
5.4.5	Special-Function Register (SFR) addressing	84
5.4.6	Register indirect addressing	85
5.4.7	Based addressing	86
5.4.8	Based indexed addressing	87
5.4.9	Stack addressing	87

CHAPTER 6 PORT FUNCTIONS **89**

6.1	Port Functions	89
6.2	Port Configuration	92
6.2.1	Port 0	92
6.2.2	Port 1	94
6.2.3	Port 2 (μ PD78064 Subseries)	95
6.2.4	Port 2 (μ PD78064Y Subseries)	97
6.2.5	Port 3	99
6.2.6	Port 7	100
6.2.7	Port 8	102
6.2.8	Port 9	103
6.2.9	Port 10	104
6.2.10	Port 11	105
6.3	Port Function Control Registers	106
6.4	Port Function Operations	111
6.4.1	Writing to input/output port	111
6.4.2	Reading from input/output port	111
6.4.3	Operations on input/output port	111

CHAPTER 7 CLOCK GENERATOR **113**

7.1	Clock Generator Functions	113
7.2	Clock Generator Configuration	113
7.3	Clock Generator Control Register	115
7.4	System Clock Oscillator	118
7.4.1	Main system clock oscillator	118
7.4.2	Subsystem clock oscillator	119
7.4.3	Scaler	121
7.4.4	When no subsystem clocks are used	121
7.5	Clock Generator Operations	122
7.5.1	Main system clock operations	123
7.5.2	Subsystem clock operations	124

7.6	Changing System Clock and CPU Clock Settings	125
7.6.1	Time required for switchover between system clock and CPU clock.....	125
7.6.2	System clock and CPU clock switching procedure	126
CHAPTER 8 16-BIT TIMER/EVENT COUNTER		127
8.1	16-Bit Timer/Event Counter Functions	129
8.2	16-Bit Timer/Event Counter Configuration	131
8.3	16-Bit Timer/Event Counter Control Registers	135
8.4	16-Bit Timer/Event Counter Operations	144
8.4.1	Interval timer operations	144
8.4.2	PWM output operations	146
8.4.3	PPG output operations	149
8.4.4	Pulse width measurement operations.....	150
8.4.5	External event counter operation.....	157
8.4.6	Square-wave output operation	159
8.4.7	One-shot pulse output operation	161
8.5	16-Bit Timer/Event Counter Operating Precautions	165
CHAPTER 9 8-BIT TIMER/EVENT COUNTERS 1 AND 2		169
9.1	8-Bit Timer/Event Counters 1 and 2 Functions	169
9.1.1	8-bit timer/event counter mode	169
9.1.2	16-bit timer/event counter mode	172
9.2	8-Bit Timer/Event Counters 1 and 2 Configurations	174
9.3	8-Bit Timer/Event Counters 1 and 2 Control Registers	178
9.4	8-Bit Timer/Event Counters 1 and 2 Operations	183
9.4.1	8-bit timer/event counter mode	183
9.4.2	16-bit timer/event counter mode	188
9.5	Cautions on 8-Bit Timer/Event Counters 1 and 2	192
CHAPTER 10 WATCH TIMER		195
10.1	Watch Timer Functions	195
10.2	Watch Timer Configuration	196
10.3	Watch Timer Control Registers	196
10.4	Watch Timer Operations	200
10.4.1	Watch timer operation.....	200
10.4.2	Interval timer operation	200
CHAPTER 11 WATCHDOG TIMER		201
11.1	Watchdog Timer Functions	201
11.2	Watchdog Timer Configuration	203
11.3	Watchdog Timer Control Registers	204
11.4	Watchdog Timer Operations	207
11.4.1	Watchdog timer operation	207
11.4.2	Interval timer operation	208

CHAPTER 12 CLOCK OUTPUT CONTROL CIRCUIT	209
12.1 Clock Output Control Circuit Functions	209
12.2 Clock Output Control Circuit Configuration	210
12.3 Clock Output Function Control Registers	211
CHAPTER 13 BUZZER OUTPUT CONTROL CIRCUIT	215
13.1 Buzzer Output Control Circuit Functions	215
13.2 Buzzer Output Control Circuit Configuration	215
13.3 Buzzer Output Function Control Registers	216
CHAPTER 14 A/D CONVERTER	219
14.1 A/D Converter Functions	219
14.2 A/D Converter Configuration	219
14.3 A/D Converter Control Registers	222
14.4 A/D Converter Operations	226
14.4.1 Basic operations of A/D converter	226
14.4.2 Input voltage and conversion results	228
14.4.3 A/D converter operating mode	229
14.5 A/D Converter Cautions	231
CHAPTER 15 SERIAL INTERFACE CHANNEL 0 (μPD78064 Subseries)	235
15.1 Serial Interface Channel 0 Functions	236
15.2 Serial Interface Channel 0 Configuration	238
15.3 Serial Interface Channel 0 Control Registers	242
15.4 Serial Interface Channel 0 Operations	249
15.4.1 Operation stop mode	249
15.4.2 3-wire serial I/O mode operation	250
15.4.3 SBI mode operation	255
15.4.4 2-wire serial I/O mode operation	281
15.4.5 $\overline{\text{SCK0}}$ /P27 pin output manipulation	287
CHAPTER 16 SERIAL INTERFACE CHANNEL 0 (μPD78064Y Subseries)	289
16.1 Serial Interface Channel 0 Functions	290
16.2 Serial Interface Channel 0 Configuration	292
16.3 Serial Interface Channel 0 Control Registers	296
16.4 Serial Interface Channel 0 Operations	303
16.4.1 Operation stop mode	303
16.4.2 3-wire serial I/O mode operation	304
16.4.3 2-wire serial I/O mode operation	308
16.4.4 I ² C bus mode operation	314
16.4.5 Cautions on use of I ² C bus mode	331
16.4.6 $\overline{\text{SCK0}}$ /SCL/P27 pin output manipulation	334

CHAPTER 17 SERIAL INTERFACE CHANNEL 2	337
17.1 Serial Interface Channel 2 Functions	337
17.2 Serial Interface Channel 2 Configuration	338
17.3 Serial Interface Channel 2 Control Registers	342
17.4 Serial Interface Channel 2 Operation	350
17.4.1 Operation stop mode	350
17.4.2 Asynchronous serial interface (UART) mode	352
17.4.3 3-wire serial I/O mode	365
CHAPTER 18 LCD CONTROLLER/DRIVER	371
18.1 LCD Controller/Driver Functions	371
18.2 LCD Controller/Driver Configuration	372
18.3 LCD Controller/Driver Control Registers	374
18.4 LCD Controller/Driver Settings	377
18.5 LCD Display Data Memory	378
18.6 Common Signals and Segment Signals	379
18.7 Supply of LCD Drive Voltages VLC0, VLC1, VLC2	383
18.8 Display Modes	387
18.8.1 Static Display Example	387
18.8.2 2-Time-Division Display Example	390
18.8.3 3-Time-Division Display Example	393
18.8.4 4-Time-Division Display Example	397
CHAPTER 19 INTERRUPT AND TEST FUNCTIONS	401
19.1 Interrupt Function Types	401
19.2 Interrupt Sources and Configuration	402
19.3 Interrupt Function Control Registers	405
19.4 Interrupt Servicing Operations	414
19.4.1 Non-maskable interrupt acknowledge operation	414
19.4.2 Maskable interrupt acknowledge operation	417
19.4.3 Software interrupt acknowledge operation	420
19.4.4 Multiple interrupt servicing	420
19.4.5 Interrupt reserve	422
19.5 Test Functions	423
19.5.1 Registers controlling the test function	423
19.5.2 Test input signal acknowledge operation	426
CHAPTER 20 STANDBY FUNCTION	427
20.1 Standby Function and Configuration	427
20.1.1 Standby function	427
20.1.2 Standby function control register	428
20.2 Standby Function Operations	429
20.2.1 HALT mode	429
20.2.2 STOP mode	432

CHAPTER 21 RESET FUNCTION.....	435
21.1 Reset Function.....	435
CHAPTER 22 μPD78P064, 78P064Y	439
22.1 Memory Size Switching Register	440
22.2 PROM Programming.....	441
22.2.1 Operating modes	441
22.2.2 PROM write procedure	443
22.2.3 PROM reading procedure.....	447
22.3 Erasure Procedure (μPD78P064KL-T and 78P064YKL-T Only)	448
22.4 Opaque Film Masking the Window (μPD78P064KL-T and 78P064YKL-T Only)	448
22.5 Screening of One-Time PROM Versions	448
CHAPTER 23 INSTRUCTION SET	449
23.1 Legends Used in Operation List	450
23.1.1 Operand identifiers and description methods	450
23.1.2 Description of "operation" column	451
23.1.3 Description of "flag operation" column	451
23.2 Operation List.....	452
23.3 Instructions Listed by Addressing Type	460

APPENDIX A DEVELOPMENT TOOLS	465
A.1 Language Processing Software	466
A.2 PROM Programming Tools	467
A.3 Debugging Tool	468
A.3.1 Hardware	468
A.3.2 Software	469
A.4 Operating Systems for IBM PC	470
 APPENDIX B EMBEDDED SOFTWARE	 475
B.1 Real-time OS	475
B.2 Fuzzy Inference Development Support System	477
 APPENDIX C REGISTER INDEX	 479
C.1 Register Name Index	479
C.2 Register Symbol Index	482
 APPENDIX D REVISION HISTORY	 485

LIST OF FIGURES (1/8)

Figure No.	Title	Page
3-1	Pin Input/Output Circuit of List	38
4-1	Pin Input/Output Circuit of List	54
5-1	Memory Map (μ PD78062, 78062Y)	57
5-2	Memory Map (μ PD78063, 78063Y)	58
5-3	Memory Map (μ PD78064, 78064Y)	59
5-4	Memory Map (μ PD78P064, 78P064Y)	60
5-5	Data Memory Addressing (μ PD78062, 78062Y)	63
5-6	Data Memory Addressing (μ PD78063, 78063Y)	64
5-7	Data Memory Addressing (μ PD78064, 78064Y)	65
5-8	Data Memory Addressing (μ PD78P064, 78P064Y)	66
5-9	Program Counter Configuration	67
5-10	Program Status Word Configuration	67
5-11	Stack Pointer Configuration	68
5-12	Data to be Saved to Stack Memory	68
5-13	Data to be Reset from Stack Memory	69
5-14	General Register Configuration	70
6-1	Port Types	89
6-2	P00 and P07 Configurations	93
6-3	P01 to P05 Configurations	93
6-4	P10 to P17 Configurations	94
6-5	P25, P26 Configurations (μ PD78064 subseries)	95
6-6	P27 Configuration (μ PD78064 subseries)	96
6-7	P25, P26 Configurations (μ PD78064Y subseries)	97
6-8	P27 Configuration (μ PD78064Y subseries)	98
6-9	P30 to P37 Configurations	99
6-10	P70 Configuration	100
6-11	P71 and P72 Configurations	101
6-12	P80 to P87 Configurations	102
6-13	P90 to P97 Configurations	103
6-14	P100 to P103 Configurations	104
6-15	P110 to P117 Configurations	105
6-16	Block Diagram of Falling Edge Detection Circuit	105
6-17	Port Mode Register Format	108
6-18	Pull-Up Resistor Option Register Format	109
6-19	Key Return Mode Register Format	110

LIST OF FIGURES (2/8)

Figure No.	Title	Page
7-1	Block Diagram of Clock Generator	114
7-2	Subsystem Clock Feedback Resistor	115
7-3	Processor Clock Control Register Format	116
7-4	Oscillation Mode Selection Register Format.....	117
7-5	Main System Clock Waveform due to Writing to OSMS	117
7-6	External Circuit of Main System Clock Oscillator	118
7-7	External Circuit of Subsystem Clock Oscillator.....	119
7-8	Examples of Oscillator with Bad Connection	119
7-9	Main System Clock Stop Function	123
7-10	System Clock and CPU Clock Switching.....	126
8-1	16-Bit Timer/Event Counter Block Diagram	132
8-2	16-Bit Timer/Event Counter Output Control Circuit Block Diagram	133
8-3	Timer Clock Selection Register 0 Format.....	136
8-4	16-Bit Timer Mode Control Register Format.....	138
8-5	Capture/Compare Control Register 0 Format.....	139
8-6	16-Bit Timer Output Control Register Format	140
8-7	Port Mode Register 3 Format	141
8-8	External Interrupt Mode Register 0 Format	142
8-9	Sampling Clock Select Register Format	143
8-10	Control Register Settings for Interval Timer Operation	144
8-11	Interval Timer Configuration Diagram	145
8-12	Interval Timer Operation Timings	145
8-13	Control Register Settings for PWM Output Operation	147
8-14	Example of D/A Converter Configuration with PWM Output	148
8-15	TV Tuner Application Circuit Example	148
8-16	Control Register Settings for PPG Output Operation	149
8-17	Control Register Settings for Pulse Width Measurement with Free-Running Counter and One Capture Register	150
8-18	Configuration Diagram for Pulse Width Measurement by Free-Running Counter	151
8-19	Timing of Pulse Width Measurement Operation by Free-Running Counter and One Capture Register (with Both Edges Specified)	151
8-20	Control Register Settings for Two Pulse Width Measurements with Free-Running Counter	152
8-21	Timing of Pulse Width Measurement Operation with Free-Running Counter (with Both Edges Specified)	153
8-22	Control Register Settings for Pulse Width Measurement with Free-Running Counter and Two Capture Registers.....	154
8-23	Timing of Pulse Width Measurement Operation by Free-Running Counter and Two Capture Registers (with Rising Edge Specified)	155
8-24	Control Register Settings for Pulse Width Measurement by Means of Restart	156
8-25	Timing of Pulse Width Measurement Operation by Means of Restart (with Rising Edge Specified)	156

LIST OF FIGURES (3/8)

Figure No.	Title	Page
8-26	Control Register Settings in External Event Counter Mode	157
8-27	External Event Counter Configuration Diagram	158
8-28	External Event Counter Operation Timings (with Rising Edge Specified)	158
8-29	Control Register Settings in Square-Wave Output Mode	159
8-30	Square-Wave Output Operation Timing	160
8-31	Control Register Settings for One-Shot Pulse Output Operation Using Software Trigger	161
8-32	Timing of One-Shot Pulse Output Operation Using Software Trigger	162
8-33	Control Register Settings for One-Shot Pulse Output Operation Using External Trigger	163
8-34	Timing of One-Shot Pulse Output Operation Using External Trigger (With Rising Edge Specified)	164
8-35	16-Bit Timer Register Start Timing	165
8-36	Timings After Change of Compare Register During Timer Count Operation	165
8-37	Capture Register Data Retention Timing	166
8-38	Operation Timing of OVF0 Flag	167
9-1	8-Bit Timer/Event Counters 1 and 2 Block Diagram	175
9-2	Block Diagram of 8-Bit Timer/Event Counter Output Control Circuit 1	176
9-3	Block Diagram of 8-Bit Timer/Event Counter Output Control Circuit 2	176
9-4	Timer Clock Select Register 1 Format	179
9-5	8-Bit Timer Mode Control Register Format	180
9-6	8-Bit Timer Output Control Register Format	181
9-7	Port Mode Register 3 Format	182
9-8	Interval Timer Operation Timings	183
9-9	External Event Counter Operation Timings (with Rising Edge Specified)	186
9-10	Interval Timer Operation Timing	188
9-11	External Event Counter Operation Timings (with Rising Edge Specified)	190
9-12	8-Bit Timer Registers 1 and 2 Start Timing	192
9-13	External Event Counter Operation Timing	192
9-14	Timing after Compare Register Change during Timer Count Operation	193
10-1	Watch Timer Block Diagram	197
10-2	Timer Clock Select Register 2 Format	198
10-3	Watch Timer Mode Control Register Format	199
11-1	Watchdog Timer Block Diagram	203
11-2	Timer Clock Select Register 2 Format	205
11-3	Watchdog Timer Mode Register Format	206

LIST OF FIGURES (4/8)

Figure No.	Title	Page
12-1	Remote Controlled Output Application Example	209
12-2	Clock Output Control Circuit Block Diagram	210
12-3	Timer Clock Select Register 0 Format	212
12-4	Port Mode Register 3 Format	213
13-1	Buzzer Output Control Circuit Block Diagram	215
13-2	Timer Clock Select Register 2 Format	217
13-3	Port Mode Register 3 Format	218
14-1	A/D Converter Block Diagram	220
14-2	A/D Converter Mode Register Format	223
14-3	A/D Converter Input Select Register Format	224
14-4	External Interrupt Mode Register 1 Format	225
14-5	A/D Converter Basic Operation	227
14-6	Relations between Analog Input Voltage and A/D Conversion Result	228
14-7	A/D Conversion by Hardware Start	229
14-8	A/D Conversion by Software Start	230
14-9	Example of Method of Reducing Current Consumption in Standby Mode	231
14-10	Analog Input Pin Disposition	232
14-11	A/D Conversion End Interrupt Generation Timing	233
14-12	Handling of AV _{DD} Pin	233
15-1	Serial Bus Interface (SBI) System Configuration Example	237
15-2	Serial Interface Channel 0 Block Diagram	239
15-3	Timer Clock Select Register 3 Format	243
15-4	Serial Operating Mode Register 0 Format	244
15-5	Serial Bus Interface Control Register Format	246
15-6	Interrupt Timing Specify Register Format	248
15-7	3-Wire Serial I/O Mode Timings	253
15-8	RELT and CMDT Operations	253
15-9	Circuit of Switching in Transfer Bit Order	254
15-10	Example of Serial Bus Configuration with SBI	255
15-11	SBI Transfer Timings	257
15-12	Bus Release Signal	258
15-13	Command Signal	258
15-14	Addresses	259
15-15	Slave Selection with Address	259
15-16	Commands	260
15-17	Data	260
15-18	Acknowledge Signal	261
15-19	$\overline{\text{BUSY}}$ and READY Signals	262
15-20	RELT, CMDT, RELD, and CMDD Operations (Master)	267

LIST OF FIGURES (5/8)

Figure No.	Title	Page
15-21	RELD and CMDD Operations (Slave)	267
15-22	ACKT Operation	268
15-23	ACKE Operations	269
15-24	ACKD Operations	270
15-25	BSYE Operation	270
15-26	Pin Configuration	273
15-27	Address Transmission from Master Device to Slave Device (WUP = 1)	275
15-28	Command Transmission from Master Device to Slave Device	276
15-29	Data Transmission from Master Device to Slave Device	277
15-30	Data Transmission from Slave Device to Master Device	278
15-31	Serial Bus Configuration Example Using 2-Wire Serial I/O Mode	281
15-32	2-Wire Serial I/O Mode Timings	285
15-33	RELT and CMDT Operations	286
15-34	$\overline{\text{SCK0}}$ /P27 Pin Configuration	287
16-1	Serial Bus Configuration Example Using I ² C Bus	291
16-2	Serial Interface Channel 0 Block Diagram	293
16-3	Timer Clock Select Register 3 Format	297
16-4	Serial Operating Mode Register 0 Format	298
16-5	Serial Bus Interface Control Register Format	299
16-6	Interrupt Timing Specify Register Format	301
16-7	3-Wire Serial I/O Mode Timings	306
16-8	RELT and CMDT Operations	306
16-9	Circuit of Switching in Transfer Bit Order	307
16-10	Serial Bus Configuration Example Using 2-Wire Serial I/O Mode	308
16-11	2-Wire Serial I/O Mode Timings	312
16-12	RELT and CMDT Operations	313
16-13	Example of Serial Bus Configuration Using I ² C Bus	314
16-14	I ² C Bus Serial Data Transfer Timing	315
16-15	Start Condition	316
16-16	Address	316
16-17	Transfer Direction Specification	316
16-18	Acknowledge Signal	317
16-19	Stop Condition	317
16-20	Wait Signal	318
16-21	Pin Configuration	323
16-22	Data Transmission from Master to Slave (Both Master and Slave Selected 9-Clock Wait)	325
16-23	Data Transmission from Slave to Master (Both Master and Slave Selected 9-Clock Wait)	328
16-24	Start Condition Output	331
16-25	Slave Wait Release (Transmission)	332

LIST OF FIGURES (6/8)

Figure No.	Title	Page
16-26	Slave Wait Release (Reception)	333
16-27	$\overline{\text{SCK0}}/\text{SCL}/\text{P27}$ Pin Configuration	334
16-28	$\overline{\text{SCK0}}/\text{SCL}/\text{P27}$ Pin Configuration	335
16-29	Logic Circuit of SCL Signal	335
17-1	Serial Interface Channel 2 Block Diagram	339
17-2	Baud Rate Generator Block Diagram	340
17-3	Serial Operating Mode Register 2 Format	342
17-4	Asynchronous Serial Interface Mode Register Format	343
17-5	Asynchronous Serial Interface Status Register Format	345
17-6	Baud Rate Generator Control Register Format	346
17-7	Asynchronous Serial Interface Transmit/Receive Data Format	359
17-8	Asynchronous Serial Interface Transmission Completion Interrupt Timing	361
17-9	Asynchronous Serial Interface Reception Completion Interrupt Timing	362
17-10	Receive Error Timing	363
17-11	3-Wire Serial I/O Mode Timing	370
18-1	LCD Controller/Driver Block Diagram	372
18-2	LCD Clock Select Circuit Block Diagram	373
18-3	LCD Display Mode Register Format	374
18-4	LCD Display Control Register Format	376
18-5	Relationship between LCD Display Data Memory Contents and Segment/Common Outputs	378
18-6	Common Signal Waveform	381
18-7	Common Signal and Static Signal Voltages and Phases	382
18-8	LCD Drive Power Supply Connection Examples (with On-Chip Split Resistor)	384
18-9	LCD Drive Power Supply Connection Examples (with External Split Resistor)	385
18-10	Example of LCD Drive Voltage Supply from Off-Chip	386
18-11	Static LCD Display Pattern and Electrode Connections	387
18-12	Static LCD Panel Connection Example	388
18-13	Static LCD Drive Waveform Examples	389
18-14	2-Time-Division LCD Display Pattern and Electrode Connections	390
18-15	2-Time-Division LCD Panel Connection Example	391
18-16	2-Time-Division LCD Drive Waveform Examples (1/2 Bias Method)	392
18-17	3-Time-Division LCD Display Pattern and Electrode Connections	393
18-18	3-Time-Division LCD Panel Connection Example	394
18-19	3-Time-Division LCD Drive Waveform Examples (1/2 Bias Method)	395
18-20	3-Time-Division LCD Drive Waveform Examples (1/3 Bias Method)	396
18-21	4-Time-Division LCD Display Pattern and Electrode Connections	397
18-22	4-Time-Division LCD Panel Connection Example	398
18-23	4-Time-Division LCD Drive Waveform Examples (1/3 Bias Method)	399

LIST OF FIGURES (7/8)

Figure No.	Title	Page
19-1	Basic Configuration of Interrupt Function	403
19-2	Interrupt Request Flag Register Format	406
19-3	Interrupt Mask Flag Register Format	407
19-4	Priority Specify Flag Register Format	408
19-5	External Interrupt Mode Register 0 Format	409
19-6	External Interrupt Mode Register 1 Format	410
19-7	Sampling Clock Select Register Format	411
19-8	Noise Remover Input/Output Timing (during rising edge detection)	412
19-9	Program Status Word Format	413
19-10	Non-Maskable Interrupt Acknowledge Flowchart	415
19-11	Non-Maskable Interrupt Acknowledge Timing	415
19-12	Non-Maskable Interrupt Request Acknowledge Operation	416
19-13	Interrupt Acknowledge Processing Algorithm	418
19-14	Interrupt Acknowledge Timing (Minimum Time)	419
19-15	Interrupt Acknowledge Timing (Maximum Time)	419
19-16	Multiple Interrupt Example	421
19-17	Interrupt Request Hold	422
19-18	Basic Configuration of Test Function	423
19-19	Format of Interrupt Request Flag Register 1L	424
19-20	Format of Interrupt Mask Flag Register 1L	424
19-21	Key Return Mode Register Format	425
20-1	Oscillation Stabilization Time Select Register Format	428
20-2	HALT Mode Clear upon Interrupt Generation	430
20-3	HALT Mode Release by $\overline{\text{RESET}}$ Input	431
20-4	STOP Mode Release by Interrupt Generation	433
20-5	Release by STOP Mode $\overline{\text{RESET}}$ Input	434
21-1	Block Diagram of Reset Function	435
21-2	Timing of Reset Input by $\overline{\text{RESET}}$ Input	436
21-3	Timing of Reset due to Watchdog Timer Overflow	436
21-4	Timing of Reset Input in STOP Mode by $\overline{\text{RESET}}$ Input	436
22-1	Memory Size Switching Register Format	440
22-2	Page Program Mode Flowchart	443
22-3	Page Program Mode Timing	444
22-4	Byte Program Mode Flowchart	445
22-5	Byte Program Mode Timing	446
22-6	PROM Read Timing	447

LIST OF FIGURES (8/8)

Figure No.	Title	Page
A-1	Development Tool Configuration	465
A-2	TGC-100SDW Drawing (For Reference Only) (Unit: mm)	472
A-3	EV-9200GF-100 Drawing (For Reference Only)	473
A-4	EV-9200GF-100 Footprint (For Reference Only)	474

LIST OF TABLES (1/3)

Table No.	Title	Page
1-1	Mask Options of Mask ROM Versions	12
2-1	Mask Options of Mask ROM Versions	24
3-1	Pin Input/Output Circuit Types	36
4-1	Pin Input/Output Circuit Types	52
5-1	Internal ROM Capacity	61
5-2	Vector Table	61
5-3	Internal High-Speed RAM Capacity	62
5-4	Special-Function Register List	73
6-1	Port Functions (μ PD78064 subseries)	90
6-2	Port Functions (μ PD78064Y subseries)	91
6-3	Port Configuration	92
6-4	Port Mode Register and Output Latch Settings when Using Dual-Functions	107
7-1	Clock Generator Configuration	113
7-2	Maximum Time Required for CPU Clock Switchover	125
8-1	Timer/Event Counter Types and Functions	128
8-2	16-Bit Timer/Event Counter Interval Times	129
8-3	16-Bit Timer/Event Counter Square-Wave Output Ranges	130
8-4	16-Bit Timer/Event Counter Configuration	131
8-5	INTP0/TI00 Pin Valid Edge and CR00 Capture Trigger Valid Edge	134
8-6	16-Bit Timer/Event Counter Interval Times	146
8-7	16-Bit Timer/Event Count Square-Wave Output Ranges	160
9-1	8-Bit Timer/Event Counters 1 and 2 Interval Times	170
9-2	8-Bit Timer/Event Counters 1 and 2 Square-Wave Output Ranges	171
9-3	Interval Times when 8-Bit Timer/Event Counters 1 and 2 are Used as 16-Bit Timer/Event Counters	172
9-4	Square-Wave Output Ranges when 8-Bit Timer/Event Counters 1 and 2 are Used as 16-Bit Timer/Event Counters	173
9-5	8-Bit Timer/Event Counters 1 and 2 Configurations	174
9-6	8-Bit Timer/Event Counter 1 Interval Time	184
9-7	8-Bit Timer/Event Counter 2 Interval Time	185
9-8	8-Bit Timer/Event Counters 1 and 2 Square-Wave Output Ranges	187
9-9	Interval Times when 2-Channel 8-Bit Timer/Event Counters (TM1 and TM2) are Used as 16-Bit Timer/Event Counter	189
9-10	Square-Wave Output Ranges when 2-Channel 8-Bit Timer/Event Counters (TM1 and TM2) are Used as 16-Bit Timer/Event Counter	191

LIST OF TABLES (2/3)

Table No.	Title	Page
10-1	Interval Timer Interval Time	195
10-2	Watch Timer Configuration	196
10-3	Interval Timer Interval Time	200
11-1	Watchdog Timer Inadvertent Program Overrun Detection Times	201
11-2	Interval Times	202
11-3	Watchdog Timer Configuration	203
11-4	Watchdog Timer Overrun Detection Time	207
11-5	Interval Timer Interval Time	208
12-1	Clock Output Control Circuit Configuration	210
13-1	Buzzer Output Control Circuit Configuration	215
14-1	A/D Converter Configuration	219
15-1	Differences between Channels 0 and 2	235
15-2	Serial Interface Channel 0 Configuration	238
15-3	Various Signals in SBI Mode	271
16-1	Differences between Channels 0 and 2	289
16-2	Serial Interface Channel 0 Configuration	292
16-3	Serial Interface Channel 0 Interrupt Request Signal Generation	295
16-4	Signals in I ² C Bus Mode	322
17-1	Serial Interface Channel 2 Configuration	338
17-2	Serial Interface Channel 2 Operating Mode Settings	344
17-3	Relation between Main System Clock and Baud Rate	348
17-4	Relation between ASCK Pin Input Frequency and Baud Rate (When BRGC is set to 00H) ..	349
17-5	Relation between Main System Clock and Baud Rate	357
17-6	Relation between ASCK Pin Input Frequency and Baud Rate (When BRGC is set to 00H) ..	358
17-7	Receive Error Causes	363
18-1	Maximum Number of Display Pixels	371
18-2	LCD Controller/Driver Configuration	372
18-3	Frame Frequencies (Hz)	375
18-4	COM Signals	379
18-5	LCD Drive Voltages	380
18-6	LCD Drive Voltages (with On-Chip Split Resistor)	383
18-7	Selection and Non-Selection Voltages (COM0)	387
18-8	Selection and Non-Selection Voltages (COM0, COM1)	390
18-9	Selection and Non-Selection Voltages (COM0 to COM2)	393
18-10	Selection and Non-Selection Voltages (COM0 to COM3)	397

LIST OF TABLES (3/3)

Table No.	Title	Page
19-1	Interrupt Source List.....	402
19-2	Various Flags Corresponding to Interrupt Request Sources	405
19-3	Times from Maskable Interrupt Request Generation to Interrupt Service	417
19-4	Interrupt Request Enabled for Multiple Interrupt during Interrupt Servicing	420
19-5	Test Input Factors	423
19-6	Flags Corresponding to Test Input Signals	423
20-1	HALT Mode Operating Status	429
20-2	Operation after HALT Mode Release	431
20-3	STOP Mode Operating Status	432
20-4	Operation after STOP Mode Release	434
21-1	Hardware Status after Reset	437
22-1	Differences among μ PD78P064, 78P064Y and Mask ROM Versions	439
22-2	Examples of Memory Size Switching Register Settings	440
22-3	PROM Programming Operating Modes	441
23-1	Operand Identifiers and Description Methods	450

www.DataSheet4U.com

[MEMO]

www.DataSheet4U.com

CHAPTER 1 OUTLINE (μ PD78064 Subseries)

1.1 Features

- On-chip high-capacity ROM and RAM

Type Part Number	Program Memory (ROM)	Data Memory	
		Internal High-Speed RAM	LCD RAM
μ PD78062	16 Kbytes	512 bytes	40 x 4 bytes
μ PD78063	24 Kbytes	1024 bytes	
μ PD78064	32 Kbytes		
μ PD78P064	32 Kbytes (Note)	1024 bytes (Note)	

Note The capacities of internal PROM and internal high-speed RAM can be changed by means of the memory size switching register.

- Instruction execution time changeable from high speed (0.4 μ s: In main system clock 5.0 MHz operation) to ultra-low speed (122 μ s: In subsystem clock 32.768 kHz operation)
- Instruction set suited to system control
 - Bit manipulation possible in all address spaces
 - Multiply and divide instructions
- Fifty-seven I/O ports (including alternative function pins for segment signal output)
- LCD Controller / Driver
 - Segment signal output: Max. 40
 - Common signal output: Max. 4
 - Bias: 1/2, 1/3 bias switching possible
 - Power supply voltage: $V_{DD} = 2.0$ to 6.0 V (Static display mode)
 $V_{DD} = 2.5$ to 6.0 V (1/3 bias method)
 $V_{DD} = 2.7$ to 6.0 V (1/2 bias method)
- 8-bit resolution A/D converter: 8 channels
- Serial interface: 2 channels
 - 3-wire/SBI/2-wire mode: 1 channel
 - 3-wire/UART mode: 1 channel
- Timer: 5 channels
 - 16-bit timer/event counter: 1 channel
 - 8-bit timer/event counter: 2 channels
 - Watch timer: 1 channel
 - Watchdog timer: 1 channel
- Twenty vectored interrupts
- Two test inputs
- Two types of on-chip clock oscillators (main system clock and subsystem clock)
- Power supply voltage: $V_{DD} = 2.0$ to 6.0 V

1.2 Applications

Cellular phones, CD players, cameras, etc.

1.3 Ordering Information

Part number	Package	Internal ROM
μ PD78062GC-xxx-7EA	100-pin plastic QFP (Fine pitch) (14 x 14 mm)	Mask ROM
μ PD78062GF-xxx-3BA	100-pin plastic QFP (14 x 20 mm)	Mask ROM
μ PD78063GC-xxx-7EA	100-pin plastic QFP (Fine pitch) (14 x 14 mm)	Mask ROM
μ PD78063GF-xxx-3BA	100-pin plastic QFP (14 x 20 mm)	Mask ROM
μ PD78064GC-xxx-7EA	100-pin plastic QFP (Fine pitch) (14 x 14 mm)	Mask ROM
μ PD78064GF-xxx-3BA	100-pin plastic QFP (14 x 20 mm)	Mask ROM
μ PD78P064GC-7EA	100-pin plastic QFP (Fine pitch) (14 x 14 mm)	One-time PROM
μ PD78P064GF-3BA	100-pin plastic QFP (14 x 20 mm)	One-time PROM
μ PD78P064KL-T*	100-pin ceramic WQFN	EPROM

* : Under development

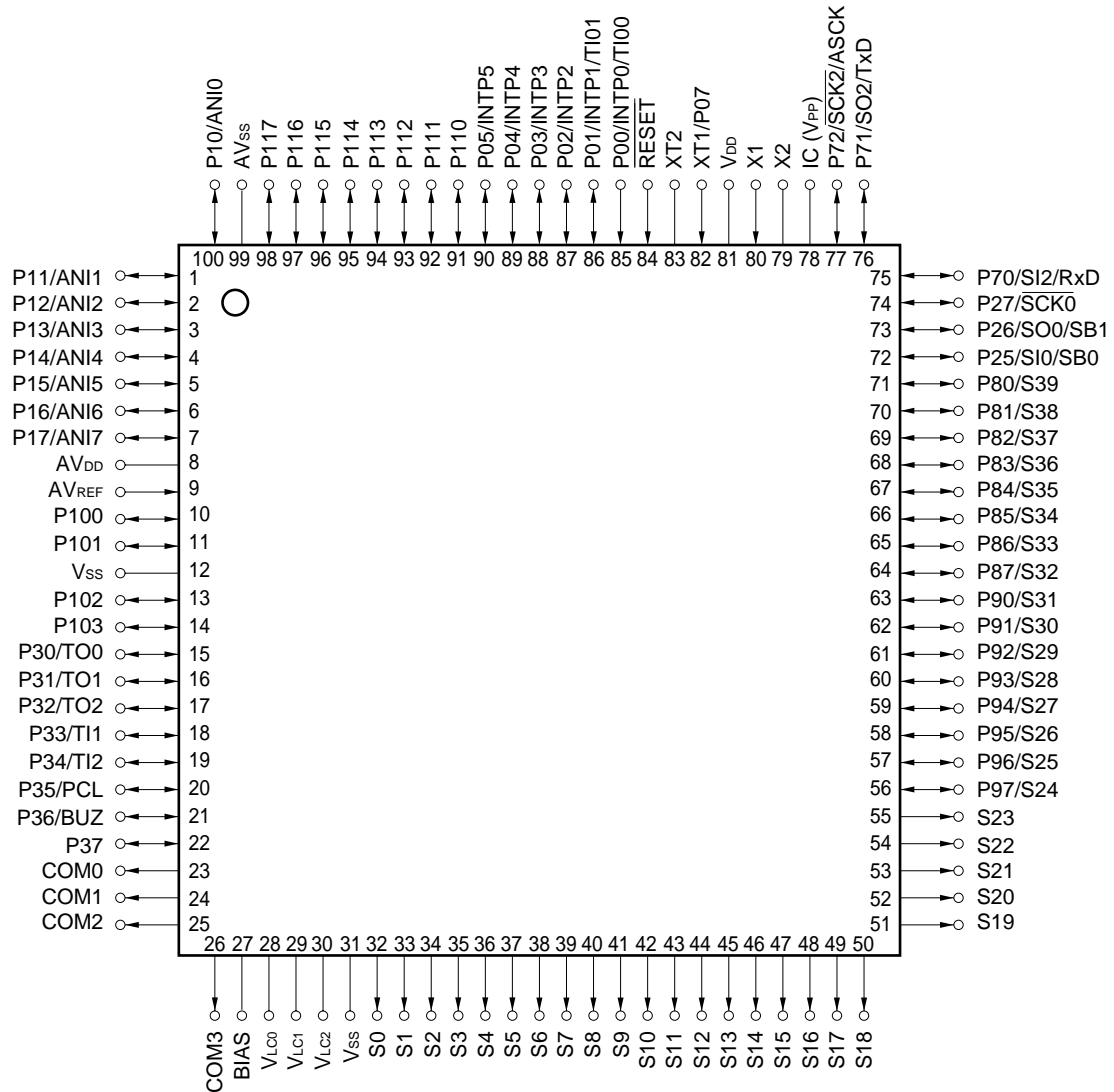
Remark xxx indicates ROM code suffix.

1.4 Pin Configuration (Top View)

(1) Normal operating mode

100-pin plastic QFP (Fine pitch) (14 x 14 mm)

μ PD78062GC-xxx-7EA, 78063GC-xxx-7EA, 78064GC-xxx-7EA, 78P064GC-7EA



- Cautions**
1. Be sure to connect IC (Internally Connected) pin to V_{SS} directly.
 2. Connect AV_{DD} pin to V_{DD}.
 3. Connect AV_{SS} pin to V_{SS}.

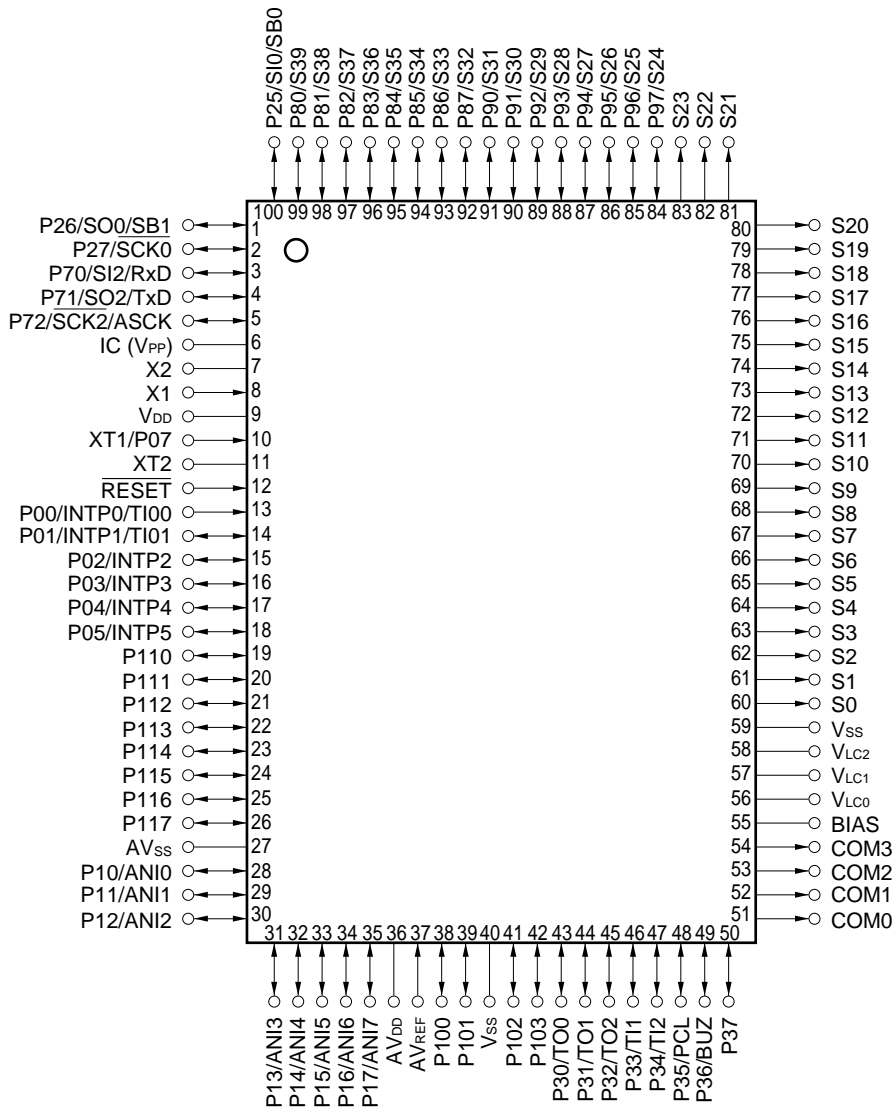
Remark Pin connection in parentheses is intended for the μ PD78P064.

100-pin plastic QFP (14 x 20 mm)

μ PD78062GF-xxx-3BA, 78063GF-xxx-3BA, 78064GF-xxx-3BA, 78P064GF-3BA

100-pin ceramic WQFN

μ PD78P064KL-T*



* : Under development

- Cautions**
1. Be sure to connect IC (Internally Connected) pin to Vss directly.
 2. Connect AVDD pin to VDD.
 3. Connect AVss pin to Vss.

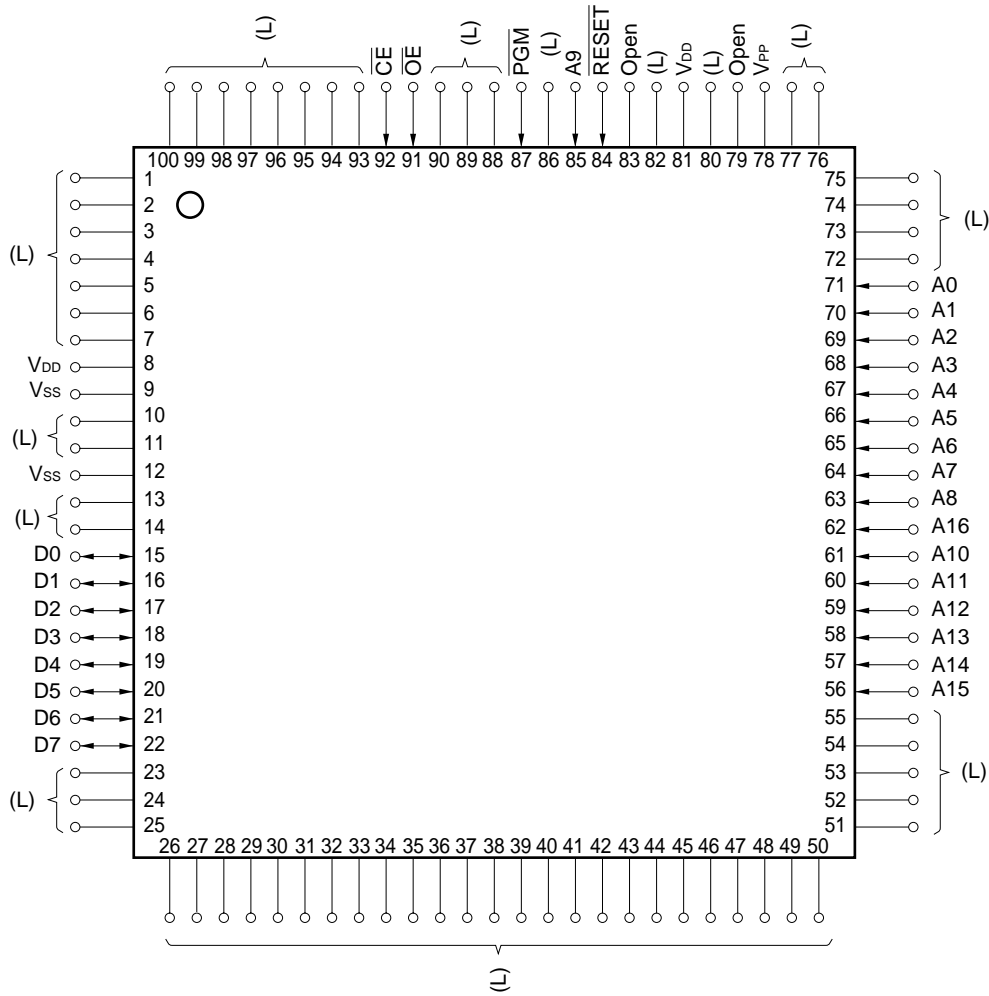
Remark Pin connection in parentheses is intended for the μ PD78P064.

P00 to P05, P07	: Port 0	ASCK	: Asynchronous Serial Clock
P10 to P17	: Port 1	PCL	: Programmable Clock
P25 to P27	: Port 2	BUZ	: Buzzer Clock
P30 to P37	: Port 3	S0 to S39	: Segment Output
P70 to P72	: Port 7	COM0 to COM3	: Common Output
P80 to P87	: Port 8	V _{LC0} to V _{LC2}	: LCD Power Supply
P90 to P97	: Port 9	BIAS	: LCD Power Supply Bias Control
P100 to P103	: Port 10	X1, X2	: Crystal (Main System Clock)
P110 to P117	: Port 11	XT1, XT2	: Crystal (Subsystem Clock)
INTP0 to INTP5	: Interrupt from Peripherals	$\overline{\text{RESET}}$: Reset
TI00, TI01	: Timer Input	ANI0 to ANI7	: Analog Input
TI1, TI2	: Timer Input	AV _{DD}	: Analog Power Supply
TO0 to TO2	: Timer Output	AV _{SS}	: Analog Ground
SB0, SB1	: Serial Bus	AV _{REF}	: Analog Reference Voltage
SI0 to SI2	: Serial Input	V _{DD}	: Power Supply
SO0 to SO2	: Serial Output	V _{PP}	: Programming Power Supply
$\overline{\text{SCK0}}$ to $\overline{\text{SCK2}}$: Serial Clock	V _{SS}	: Ground
RxD	: Receive Data	IC	: Internally Connected
TxD	: Transmit Data		

(2) PROM programming mode

100-pin plastic QFP (Fine pitch) (14 x 14 mm)

μ PD78P064GC-7EA



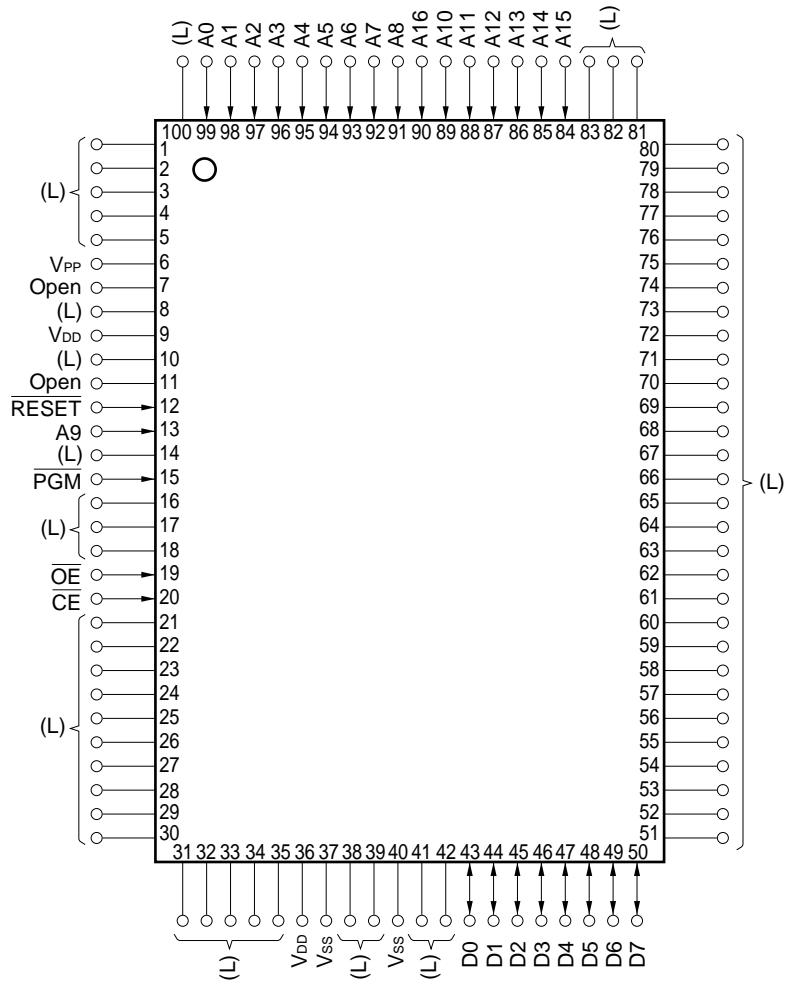
- Cautions**
1. (L) : Connect individually to V_{SS} via a pull-down resistor.
 2. V_{SS} : Connect to the ground.
 3. \overline{RESET} : Set to the low level.
 4. Open : Do not connect anything.

100-pin plastic QFP (14 x 20 mm)

μ PD78P064GF-3BA

100-pin ceramic WQFN

μ PD78P064KL-T*



* : Under development

- Cautions**
1. (L) : Connect individually to Vss via a pull-down resistor.
 2. Vss : Connect to the ground.
 3. $\overline{\text{RESET}}$: Set to the low level.
 4. Open : Do not connect anything.

A0 to A16 : Address Bus

D0 to D7 : Data Bus

$\overline{\text{CE}}$: Chip Enable

$\overline{\text{OE}}$: Output Enable

PGM : Program

$\overline{\text{RESET}}$: Reset

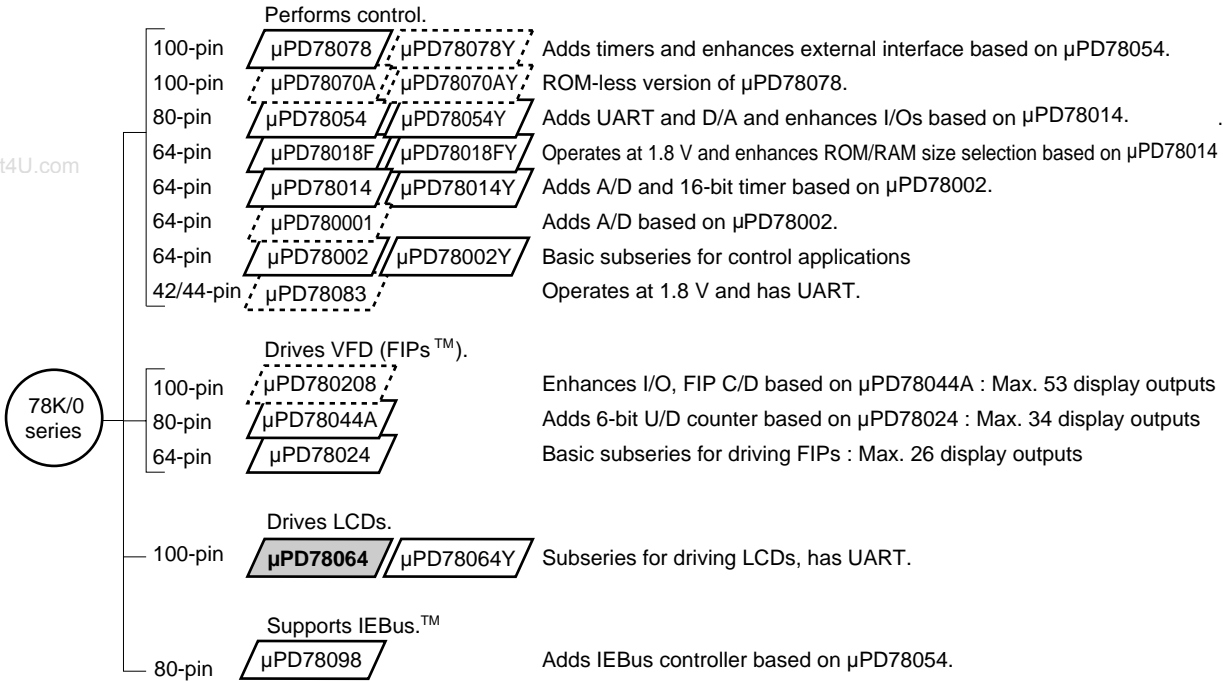
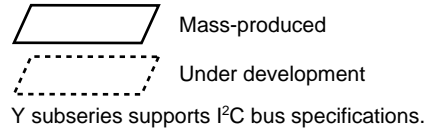
VDD : Power Supply

VPP : Programming Power Supply

Vss : Ground

✧ 1.5 78K/0 Series Expansion

78K/0 series products evolution is illustrated below. Part numbers in the boxes indicate subseries names.



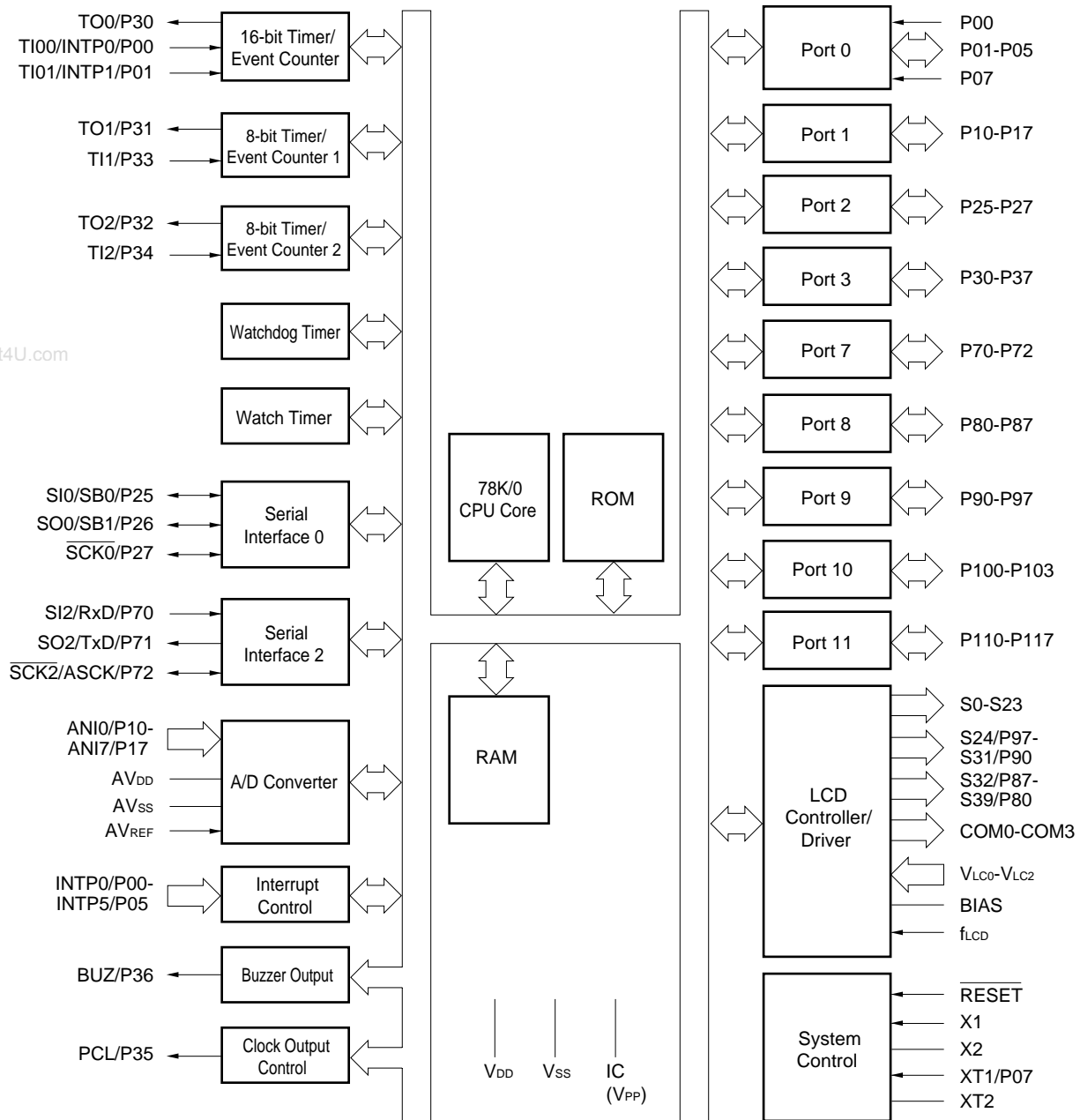
www.DataSheet4U.com

Major differences among these subseries are tabulated below.

Function Subseries		ROM capacity	Timer				8-bit A/D	8-bit D/A	Serial Interface	I/O	V _{DD} MIN	External extension
			8-bit	16-bit	Watch	Watchdog						
Control	μ PD78078	32K-60K	4ch	1ch	1ch	1ch	8ch	2ch	3ch(UART:1ch)	88	1.8 V	√
	μ PD78070A	—								61	2.7 V	
	μ PD78054	16K-60K	2ch	—	—	—	—	—	2ch	69	2.0 V	—
	μ PD78018F	8K-48K								53	1.8 V	
	μ PD78014	8K-32K	—	—	—	—	—	—	1ch	53	2.7 V	—
	μ PD780001	8K								39	—	
	μ PD78002	8K-16K	—	—	1ch	—	—	—	—	53	—	√
	μ PD78083											
FIP drive	μ PD780208	32K-40K	2ch	1ch	1ch	1ch	8ch	—	2ch	74	2.7 V	—
	μ PD78044A	16K-40K								68		
	μ PD78024	24K-32K								54		
LCD drive	μ PD78064	16K-32K	2ch	1ch	1ch	1ch	8ch	—	2ch(UART:1ch)	57	2.0 V	—
IEbus Support	μ PD78098	32K-60K	2ch	1ch	1ch	1ch	8ch	2ch	3ch(UART:1ch)	69	2.7 V	√

www.DataSheet4U.com

1.6 Block Diagram



- Remarks**
1. The internal ROM and RAM capacities depend on the product.
 2. Pin connection in parentheses is intended for the μ PD78P064.

1.7 Outline of Function

Item		Part Number	μ PD78062	μ PD78063	μ PD78064	μ PD78P064	
Internal memory	ROM	Mask ROM				PROM	
		16 Kbytes	24 Kbytes	32 Kbytes	32 Kbytes ^{Note}		
	Internal high-speed RAM	512 bytes	1024 bytes		1024 bytes ^{Note}		
	LCD RAM	40 x 4 bits					
General register		8 bits x 8 x 4 banks					
Instruction cycle	With main system clock selected	0.4 μ s/0.8 μ s/1.6 μ s/3.2 μ s/6.4 μ s/12.8 μ s (@ 5.0 MHz)					
	With subsystem clock selected	122 μ s (@ 32.768 kHz)					
Instruction set		<ul style="list-style-type: none"> • 16-bit operation • Multiply/divide (8 bits x 8 bits, 16 bits ÷ 8 bits) • Bit manipulate (set, reset, test, and Boolean operation) • BCD adjust, etc. 					
I/O port (including alternative function pins for segment signal output)		<ul style="list-style-type: none"> • Total : 57 • CMOS input : 2 • CMOS I/O : 55 					
A/D converter		8-bit resolution x 8 channels					
LCD controller / driver		<ul style="list-style-type: none"> • Segment signal output: Max. 40 • Common signal output: Max. 4 • Bias: 1/2, 1/3 bias switching possible 					
Serial interface		<ul style="list-style-type: none"> • 3-wire/SBI/2-wire mode selection possible : 1 channel • 3-wire mode / UART mode selection possible : 1 channel 					
Timer		<ul style="list-style-type: none"> • 16-bit timer/event counter : 1 channel • 8-bit timer/event counter : 2 channels • Watch timer : 1 channel • Watchdog timer : 1 channel 					
Timer output		Three outputs: (14-bit PWM output enable: 1)					
Clock output		19.5 kHz, 39.1 kHz, 78.1 kHz, 156 kHz, 313 kHz, 625 kHz, 1.25 MHz, 2.5 MHz, 5.0 MHz (@ 5.0 MHz with main system clock) 32.768 kHz (@ 32.768 kHz with subsystem clock)					
Buzzer output		1.2 kHz, 2.4 kHz, 4.9 kHz, 9.8 kHz (@ 5.0 MHz with main system clock)					

Note The capacities of the internal PROM and the internal high-speed RAM can be changed using the memory size switching register.

Item		Part Number	μ PD78062	μ PD78063	μ PD78064	μ PD78P064
Vectored interrupt	Maskable interrupt		Internal: 12 External: 6			
	Non-maskable interrupt		Internal: 1			
	Software interrupt		Internal: 1			
Test input			Internal: 1 External: 1			
Power supply voltage			$V_{DD} = 2.0$ to 6.0 V			
Operating ambient temperature			$T_A = -40$ to $+85$ °C			
Package			<ul style="list-style-type: none"> • 100-pin plastic QFP (Fine pitch) (14 x 14 mm) • 100-pin plastic QFP (14 x 20 mm) • 100-pin ceramic WQFN Note (μPD78P064 only) 			

Note Under development

* 1.8 Mask Options

The mask ROM versions (μ PD78062, 78063, 78064) provide split resistor mask options. By specifying this mask options at the time of ordering, split registers which enable to generate LCD drive voltage suited to each bias method type can be incorporated. Using this mask option reduces the number of components to add to the device, resulting in board space saving.

The mask options provided in the μ PD78064 subseries are shown in Table 1-1.

Table 1-1. Mask Options of Mask ROM Versions

Pin names	Mask options
V_{LC0} - V_{LC2}	Split register can be incorporated.

2.1 Features

- On-chip high-capacity ROM and RAM

Type Part Number	Program Memory (ROM)	Data Memory	
		Internal High-Speed RAM	LCD RAM
μ PD78062Y	16 Kbytes	512 bytes	40 x 4 bytes
μ PD78063Y	24 Kbytes	1024 bytes	
μ PD78064Y	32 Kbytes		
μ PD78P064Y	32 Kbytes (Note)	1024 bytes (Note)	

Note The capacities of internal PROM and internal high-speed RAM can be changed by means of the memory size switching register.

- Instruction execution time changeable from high speed (0.4 μ s: In main system clock 5.0 MHz operation) to ultra-low speed (122 μ s: In subsystem clock 32.768 kHz operation)
- Instruction set suited to system control
 - Bit manipulation possible in all address spaces
 - Multiply and divide instructions
- Fifty-seven I/O ports (including alternative function pins for segment signal output)
- LCD Controller / Driver
 - Segment signal output: Max. 40
 - Common signal output: Max. 4
 - Bias: 1/2, 1/3 bias switching possible
 - Power supply voltage: $V_{DD} = 2.0$ to 6.0 V (Static display mode)
 $V_{DD} = 2.5$ to 6.0 V (1/3 bias method)
 $V_{DD} = 2.7$ to 6.0 V (1/2 bias method)
- 8-bit resolution A/D converter: 8 channels
- Serial interface: 2 channels
 - 3-wire//2-wire/I²C bus mode: 1 channel
 - 3-wire/UART mode: 1 channel
- Timer: 5 channels
 - 16-bit timer/event counter : 1 channel
 - 8-bit timer/event counter : 2 channels
 - Watch timer : 1 channel
 - Watchdog timer : 1 channel
- Twenty vectored interrupts
- Two test inputs
- Two types of on-chip clock oscillators (main system clock and subsystem clock)
- Power supply voltage: $V_{DD} = 2.0$ to 6.0 V

2.2 Applications

Cellular phones, CD players, cameras, audio equipment, etc.

2.3 Ordering Information

Part number	Package	Internal ROM
μ PD78062YGC-xxx-7EA	100-pin plastic QFP (Fine pitch) (14 x 14 mm)	Mask ROM
μ PD78062YGF-xxx-3BA	100-pin plastic QFP (14 x 20 mm)	Mask ROM
μ PD78063YGC-xxx-7EA	100-pin plastic QFP (Fine pitch) (14 x 14 mm)	Mask ROM
μ PD78063YGF-xxx-3BA	100-pin plastic QFP (14 x 20 mm)	Mask ROM
μ PD78064YGC-xxx-7EA	100-pin plastic QFP (Fine pitch) (14 x 14 mm)	Mask ROM
μ PD78064YGF-xxx-3BA	100-pin plastic QFP (14 x 20 mm)	Mask ROM
μ PD78P064YGC-7EA*	100-pin plastic QFP (Fine pitch) (14 x 14 mm)	One-time PROM
μ PD78P064YGF-3BA*	100-pin plastic QFP (14 x 20 mm)	One-time PROM
μ PD78P064YKL-T*	100-pin ceramic WQFN	EPROM

* : Under development

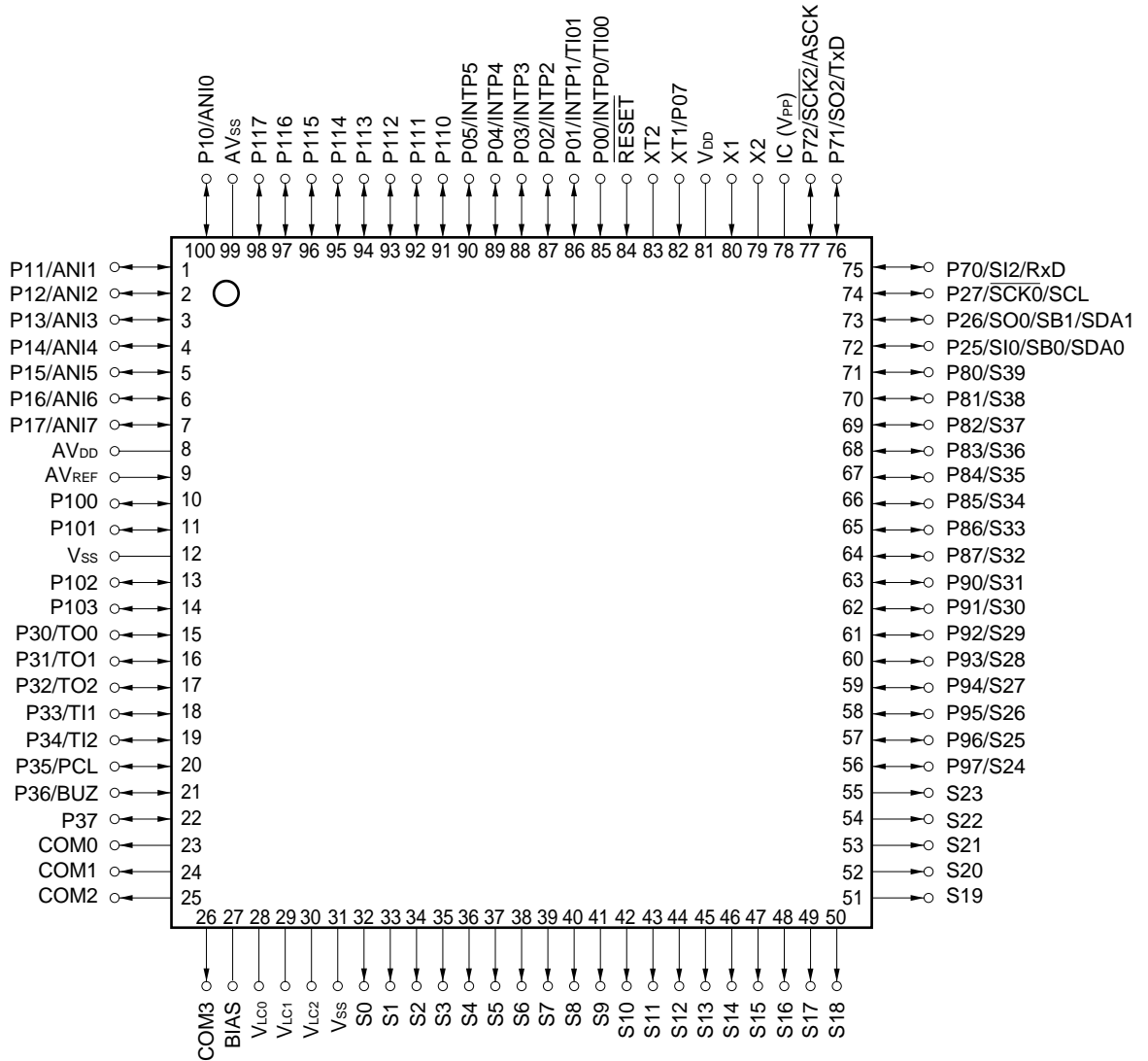
Remark xxx indicates ROM code suffix.

2.4 Pin Configuration (Top View)

(1) Normal operating mode

100-pin plastic QFP (Fine pitch) (14 x 14 mm)

μ PD78062YGC-xxx-7EA, 78063YGC-xxx-7EA, 78064YGC-xxx-7EA, 78P064YGC-7EA*



* : Under development

- Cautions**
1. Be sure to connect IC (Internally Connected) pin to V_{SS} directly.
 2. Connect AV_{DD} pin to V_{DD}.
 3. Connect AV_{SS} pin to V_{SS}.

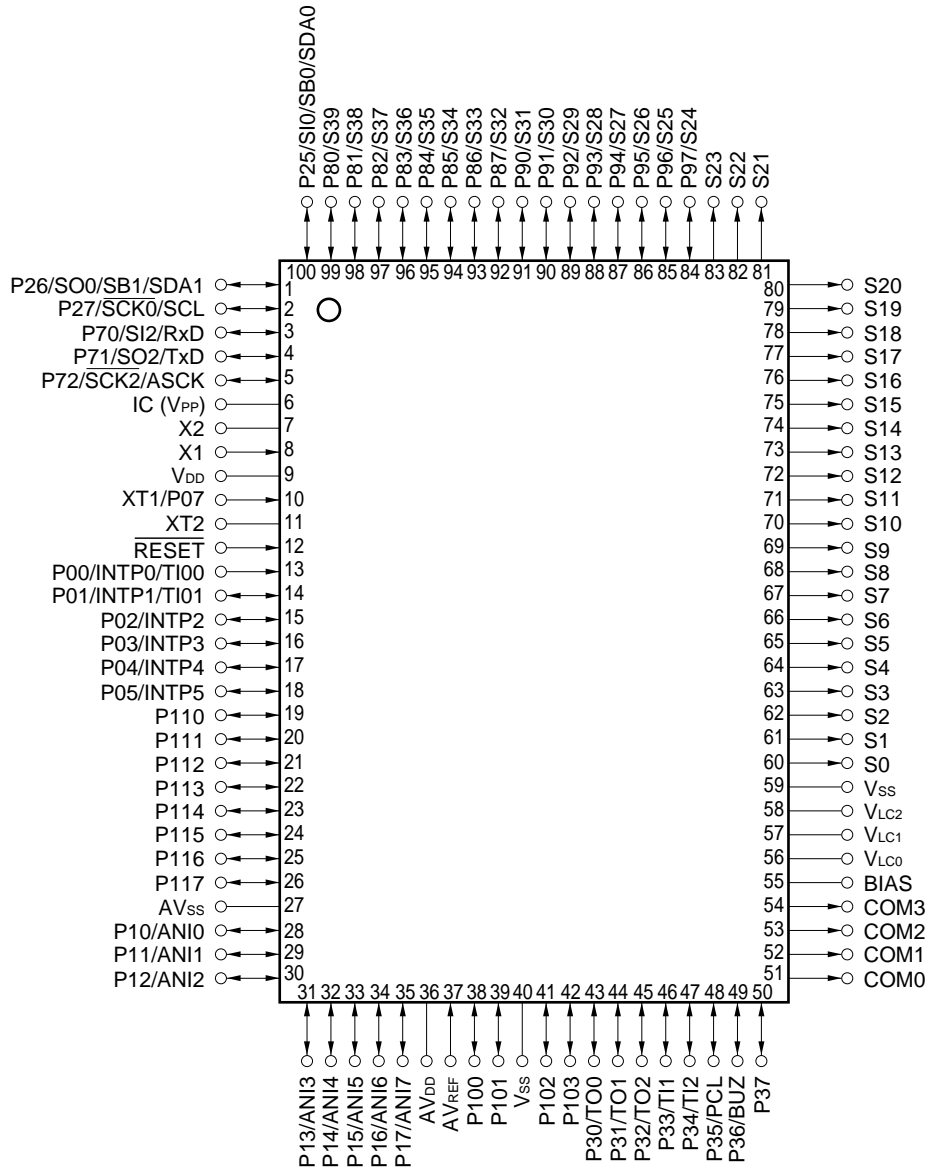
Remark Pin connection in parentheses is intended for the μ PD78P064Y.

100-pin plastic QFP (14 x 20 mm)

μ PD78062YGF-xxx-3BA, 78063YGF-xxx-3BA, 78064YGF-xxx-3BA, 78P064YGF-3BA*

100-pin ceramic WQFN

μ PD78P064YKL-T*



* : Under development

- Cautions**
1. Be sure to connect IC (Internally Connected) pin to V_{SS} directly.
 2. Connect AV_{DD} pin to V_{DD}.
 3. Connect AV_{SS} pin to V_{SS}.

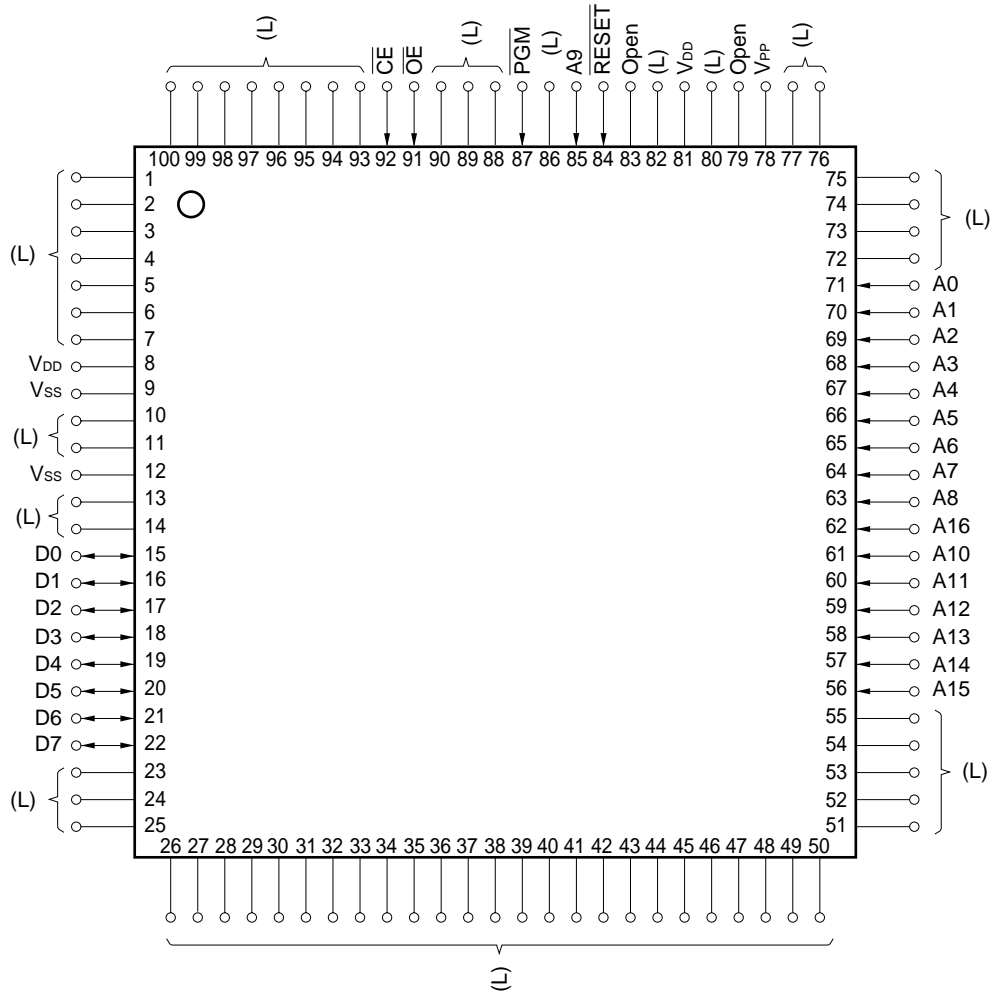
Remark Pin connection in parentheses is intended for the μ PD78P064Y.

P00 to P05, P07	: Port 0	TxD	: Transmit Data
P10 to P17	: Port 1	ASCK	: Asynchronous Serial Clock
P25 to P27	: Port 2	PCL	: Programmable Clock
P30 to P37	: Port 3	BUZ	: Buzzer Clock
P70 to P72	: Port 7	S0 to S39	: Segment Output
P80 to P87	: Port 8	COM0 to COM3	: Common Output
P90 to P97	: Port 9	V _{Lc0} to V _{Lc2}	: LCD Power Supply
P100 to P103	: Port 10	BIAS	: LCD Power Supply Bias Control
P110 to P117	: Port 11	X1, X2	: Crystal (Main System Clock)
INTP0 to INTP5	: Interrupt from Peripherals	XT1, XT2	: Crystal (Subsystem Clock)
TI00, TI01	: Timer Input	$\overline{\text{RESET}}$: Reset
TI1, TI2	: Timer Input	ANI0 to ANI7	: Analog Input
TO0 to TO2	: Timer Output	AV _{DD}	: Analog Power Supply
SB0, SB1	: Serial Bus	AV _{SS}	: Analog Ground
SI0 to SI2	: Serial Input	AV _{REF}	: Analog Reference Voltage
SO0 to SO2	: Serial Output	V _{DD}	: Power Supply
$\overline{\text{SCK0}}$ to $\overline{\text{SCK2}}$: Serial Clock	V _{PP}	: Programming Power Supply
SDA0, SDA1	: Serial Data	V _{SS}	: Ground
SCL	: Serial Clock	IC	: Internally Connected
RxD	: Receive Data		

(2) PROM programming mode

100-pin plastic QFP (Fine pitch) (14 x 14 mm)

μ PD78P064YGC-7EA*



* : Under development

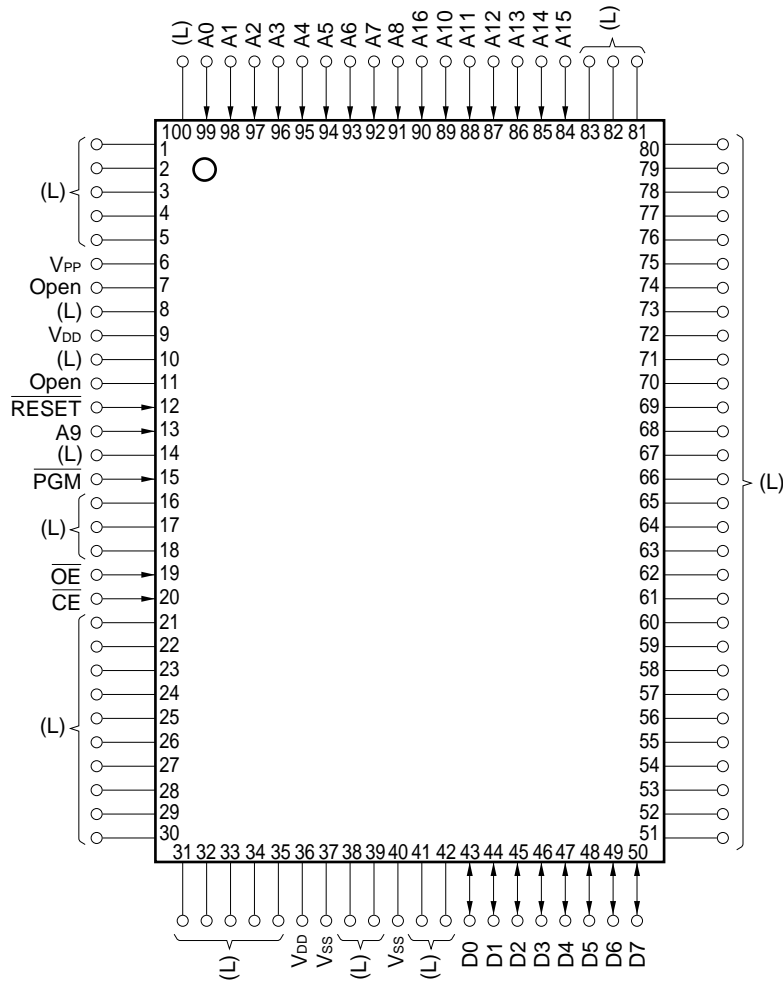
- Cautions**
1. (L) : Connect individually to Vss via a pull-down resistor.
 2. Vss : Connect to the ground.
 3. RESET : Set to the low level.
 4. Open : Do not connect anything.

100-pin plastic QFP (14 x 20 mm)

μ PD78P064YGF-3BA*

100-pin ceramic WQFN

μ PD78P064YKL-T*



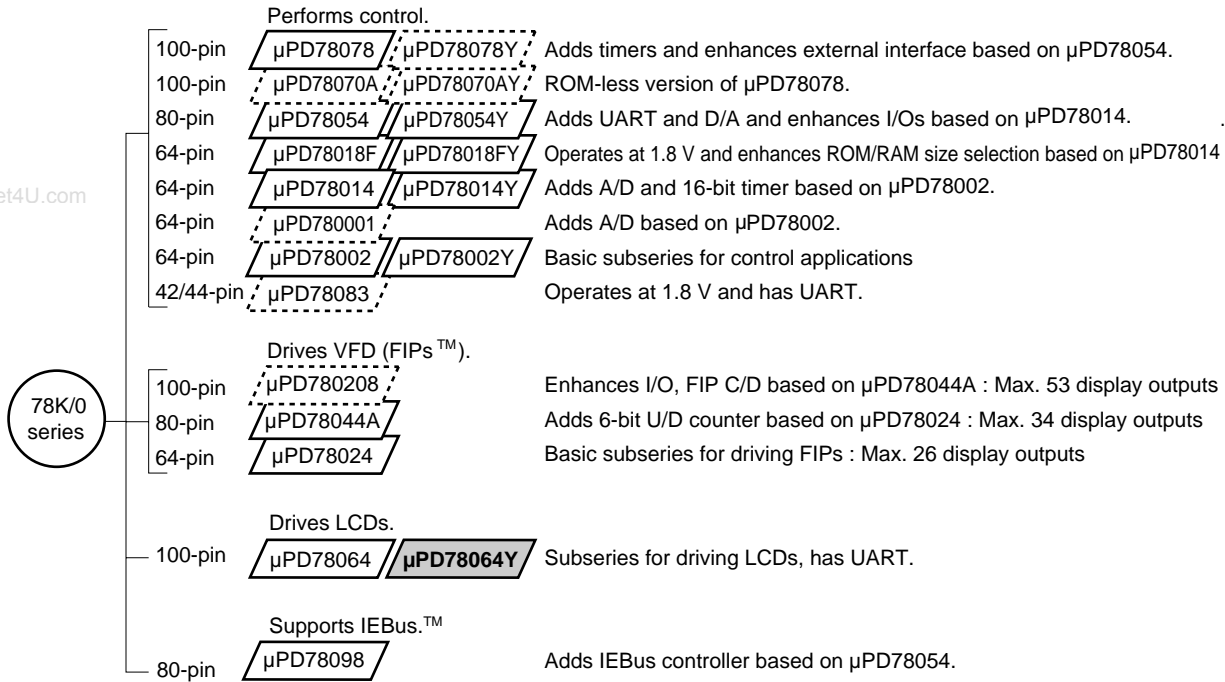
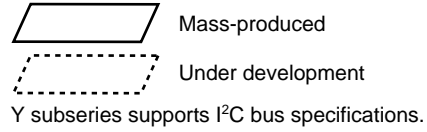
* : Under development

- Cautions**
1. (L) : Connect individually to V_{ss} via a pull-down resistor.
 2. V_{ss} : Connect to the ground.
 3. $\overline{\text{RESET}}$: Set to the low level.
 4. Open : Do not connect anything.

A0 to A16	: Address Bus	$\overline{\text{RESET}}$: Reset
D0 to D7	: Data Bus	V _{DD}	: Power Supply
$\overline{\text{CE}}$: Chip Enable	V _{PP}	: Programming Power Supply
$\overline{\text{OE}}$: Output Enable	V _{SS}	: Ground
PGM	: Program		

✧ 2.5 78K/0 Series Expansion

78K/0 series products evolution is illustrated below. Part numbers in the boxes indicates subseries names.



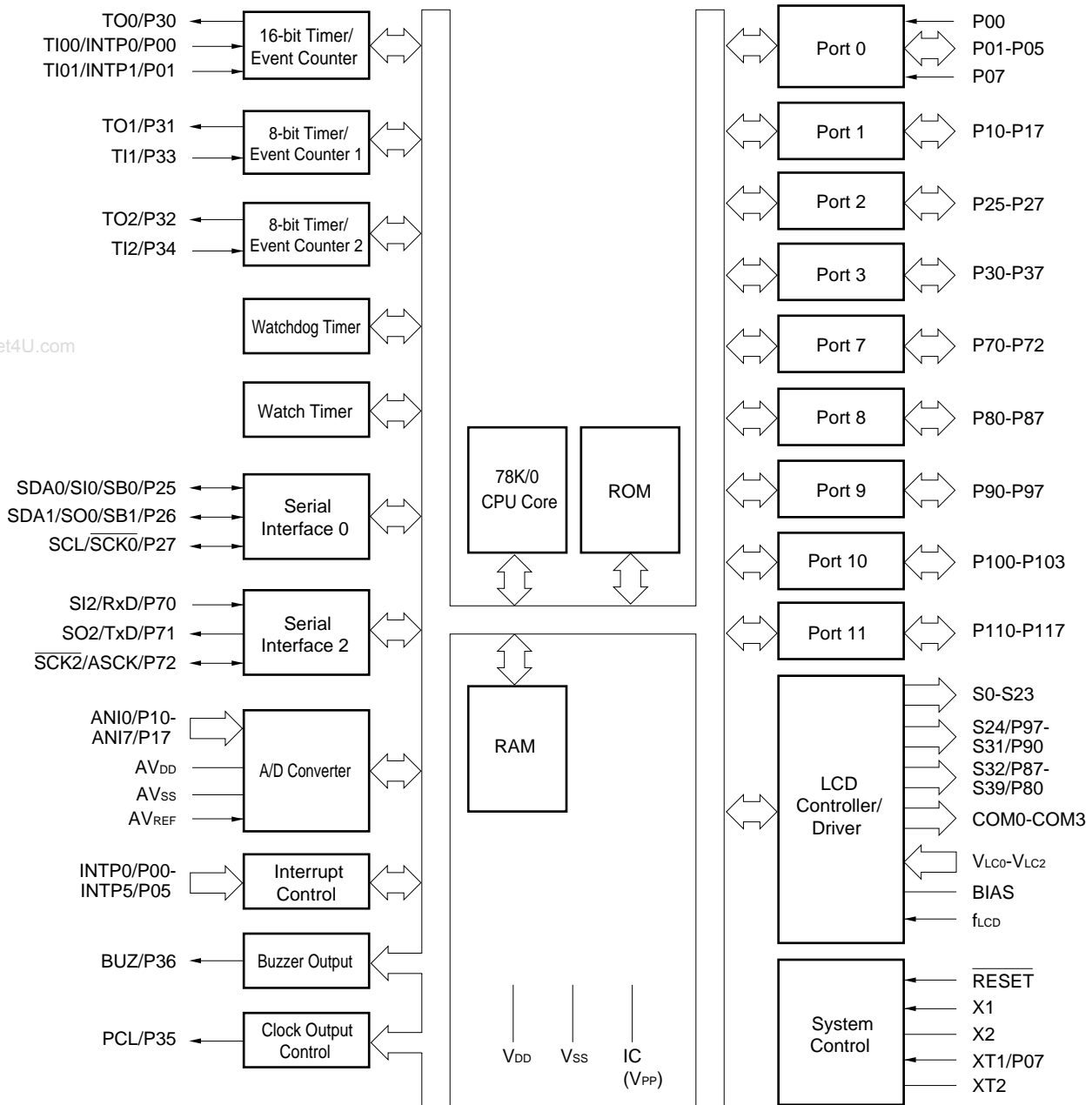
www.DataSheet4U.com

Major differences among these subseries are tabulated below.

Function Subseries		ROM capacity	Timer				8-bit A/D	8-bit D/A	Serial Interface	I/O	V _{DD} MIN	External extension
			8-bit	16-bit	Watch	Watchdog						
Control	μ PD78078	32K-60K	4ch	1ch	1ch	1ch	8ch	2ch	3ch(UART:1ch)	88	1.8 V	√
	μ PD78070A	—								61	2.7 V	
	μ PD78054	16K-60K	2ch	—	—	—	—	2ch	69	2.0 V	—	
	μ PD78018F	8K-48K							53	1.8 V		
	μ PD78014	8K-32K	—	—	—	—	—	1ch	53	2.7 V	—	
	μ PD780001	8K							39	—		
	μ PD78002	8K-16K	—	—	1ch	—	—	—	53	—	√	
	μ PD78083											8ch
FIP drive	μ PD780208	32K-40K	2ch	1ch	1ch	1ch	8ch	—	2ch	74	2.7 V	—
	μ PD78044A	16K-40K								68		
	μ PD78024	24K-32K								54		
LCD drive	μ PD78064	16K-32K	2ch	1ch	1ch	1ch	8ch	—	2ch(UART:1ch)	57	2.0 V	—
IEbus Support	μ PD78098	32K-60K	2ch	1ch	1ch	1ch	8ch	2ch	3ch(UART:1ch)	69	2.7 V	√

www.DataSheet4U.com

2.6 Block Diagram



- Remarks**
1. The internal ROM and RAM capacities depend on the product.
 2. Pin connection in parentheses is intended for the μ PD78P064.

2.7 Outline of Function

Item		Part Number	μPD78062Y	μPD78063Y	μPD78064Y	μPD78P064Y ^{Note1}
Internal memory	ROM		Mask ROM			PROM
			16 Kbytes	24 Kbytes	32 Kbytes	32 Kbytes ^{Note2}
	Internal high-speed RAM		512 bytes	1024 bytes		1024 bytes ^{Note2}
	LCD RAM		40 x 4 bits			
General register			8 bits x 8 x 4 banks			
Instruction Cycle	With main system clock selected		0.4 μs/0.8 μs/1.6 μs/3.2 μs/6.4 μs/12.8 μs (@ 5.0 MHz)			
	With subsystem clock selected		122 μs (@ 32.768 kHz)			
Instruction set			<ul style="list-style-type: none"> • 16-bit operation • Multiply/divide (8 bits x 8 bits, 16 bits + 8 bits) • Bit manipulate (set, reset, test, and Boolean operation) • BCD adjust, etc. 			
I/O port (including alternative function pins for segment signal output)			<ul style="list-style-type: none"> • Total : 57 • CMOS input : 2 • CMOS I/O : 55 			
A/D converter			8-bit resolution x 8 channels			
LCD controller / driver			<ul style="list-style-type: none"> • Segment signal output: Max. 40 • Common signal output: Max. 4 • Bias: 1/2, 1/3 bias switching possible 			
Serial interface			<ul style="list-style-type: none"> • 3-wire/2-wire/I²C bus mode selection possible: 1 channel • 3-wire mode / UART mode selection possible: 1 channel 			
Timer			<ul style="list-style-type: none"> • 16-bit timer/event counter : 1 channel • 8-bit timer/event counter : 2 channels • Watch timer : 1 channel • Watchdog timer : 1 channel 			
Timer output			Three outputs: (14-bit PWM output enable: 1)			
Clock output			19.5 kHz, 39.1 kHz, 78.1 kHz, 156 kHz, 313 kHz, 625 kHz, 1.25 MHz, 2.5 MHz, 5.0 MHz (@ 5.0 MHz with main system clock) 32.768 kHz (@ 32.768 kHz with subsystem clock)			
Buzzer output			1.2 kHz, 2.4 kHz, 4.9 kHz, 9.8 kHz (@ 5.0 MHz with main system clock)			

- Notes**
1. Under development
 2. The capacities of the internal PROM and the internal high-speed RAM can be changed using the memory switching register.

Item		Part Number	μ PD78062Y	μ PD78063Y	μ PD78064Y	μ PD78P064Y ^{Note}
Vectored interrupt	Maskable interrupt	Internal: 12 External: 6				
	Non-maskable interrupt	Internal: 1				
	Software interrupt	Internal: 1				
Test input		Internal: 1 External: 1				
Power supply voltage		$V_{DD} = 2.0$ to 6.0 V				
Operating ambient temperature		$T_A = -40$ to $+85$ °C				
Package		<ul style="list-style-type: none"> • 100-pin plastic QFP (Fine pitch) (14 x 14 mm) • 100-pin plastic QFP (14 x 20 mm) • 100-pin ceramic WQFN (μPD78P064Y only) 				

Note Under development

2.8 Mask Options

The mask ROM versions (μ PD78062Y, 78063Y, 78064Y) provide split resistor mask options. By specifying this mask options at the time of ordering, split registers which enable to generate LCD drive voltage suited to each bias method type can be incorporated. Using this mask option reduces the number of components to add to the device, resulting in board space saving.

The mask options provided in the μ PD78064Y subseries are shown in Table 2-1.

Table 2-1. Mask Options of Mask ROM Versions

Pin names	Mask options
V_{LC0} - V_{LC2}	Split register can be incorporated.

CHAPTER 3 PIN FUNCTION (μ PD78064 Subseries)

3.1 Pin Function List

3.1.1 Normal operating mode pins

(1) Port pins (1/2)

Pin Name	Input/Output	Function		After Reset	Alternative Function
P00	Input	Port 0.	Input only	Input	INTP0/TI00
P01	Input/	7-bit input/output port. Input/output mode can be specified bit-wise. If used as an input port, a pull-up resistor can be connected by software.		Input	INTP1/TI01
P02	output				INTP2
P03					INTP3
P04					INTP4
P05					INTP5
P07 ^{Note1}	Input		Input only	Input	XT1
P10 to P17	Input/ output	Port 1. 8-bit input/output port. Input/output mode can be specified bit-wise. If used as input port, a pull-up resistor can be connected by software ^{Note2} .		Input	ANI0 to ANI7
P25	Input/	Port 2.		Input	SI0/SB0
P26	output/	3-bit input/output port. Input/output mode can be specified bit-wise.			SO0/SB1
P27		If used as an input port, a pull-up resistor can be connected by software.			$\overline{\text{SCK0}}$
P30	Input/	Port 3.		Input	TO0
P31	output	8-bit input/output port. Input/output mode can be specified bit-wise.			TO1
P32		If used as an input port, a pull-up resistor can be connected by software.			TO2
P33					TI1
P34					TI2
P35					PCL
P36					BUZ
P37					—

- Notes**
1. When the P07/XT1 pin is used as an input port, set the bit 6 (FRC) of the processor clock control register to 1 (do not use the feedback resistor internal to the subsystem clock oscillator).
 2. When pins P10/ANI0 to P17/ANI7 are used as an analog input of the A/D converter, the pull-up resistor is automatically disabled.

(1) Port pins (2/2)

Pin Name	Input/Output	Function	After Reset	Alternative Function
P70	Input/ output	Port 7.	Input	SI2/RxD
P71		3-bit input/output port.		SO2/TxD
P72		Input/output mode can be specified bit-wise. If used as an input port, a pull-up resistor can be connected by software.		$\overline{\text{SCK2}}/\text{ASCK}$
P80 to P87	Input/ output	Port 8. 8-bit input/output port. Input/output mode can be specified bit-wise. If used as an input port, a pull-up resistor can be connected by software. I/O port / segment signal output can be specified in 2-bit units by LCD control register.	Input	S39 to S32
P90 to P97	Input/ output	Port 9. 8-bit input/output port. Input/output mode can be specified bit-wise. If used as an input port, a pull-up resistor can be connected by software. I/O port / segment signal output can be specified in 2-bit units by LCD control register.	Input	S31 to S24
P100 to P103	Input/ output	Port 10. 4-bit input/output port. Input/output mode can be specified bit-wise. If used as an input port, a pull-up resistor can be connected by software. A resistor can be connected. LED can be driven directly.	Input	—
P110 to 117	Input/ Output	Port 11. 8-bit input/output port. Input/output mode can be specified bit-wise. If used as an input port, a pull-up resistor can be connected by software. Falling edge can be detected.	Input	—

(2) Pins other than port pins (1/2)

Pin Name	Input/Output	Function	After Reset	Alternative Function
INTP0	Input	External interrupt inputs with specifiable valid edges (rising edge, falling edge, both rising and falling edges).	Input	P00/TI00
INTP1				P01/TI01
INTP2				P02
INTP3				P03
INTP4				P04
INTP5				P05
SI0	Input	Serial interface serial data input	Input	P25/SB0
SI2				P70/RxD
SO0	Output	Serial interface serial data output	Input	P26/SB1
SO2				P71/TxD
SB0	Input/ output	Serial interface serial data input/output	Input	P25/SI0
SB1				P26/SO0
$\overline{\text{SCK0}}$	Input/ output	Serial interface serial clock input/output	Input	P27
$\overline{\text{SCK2}}$				P72/ASCK
RxD	Input	Asynchronous serial interface serial data input	Input	P70/SI2
TxD	Output	Asynchronous serial interface serial data output	Input	P71/SO2
ASCK	Input	Asynchronous serial interface serial clock input	Input	P72/ $\overline{\text{SCK2}}$
TI00	Input	External count clock input to 16-bit timer (TM0)	Input	P00/INTP0
TI01		Capture trigger signal input to capture register (CR00)		P01/INTP1
TI1		External count clock input to 8-bit timer (TM1)		P33
TI2		External count clock input to 8-bit timer (TM2)		P34
TO0	Output	16-bit timer output (also used for 14-bit PWM output)	Input	P30
TO1		8-bit timer output		P31
TO2				P32
PCL	Output	Clock output (for main system clock and subsystem clock trimming)	Input	P35
BUZ	Output	Buzzer output	Input	P36
S0 to S23	Output	Segment signal output of LCD controller/driver	Output	—
S24 to S31			Input	P97 to P90
S32 to S39				P87 to P80
COM0-COM3	Output	Common signal output of LCD controller/driver	Output	—
V _{LC0} to V _{LC2}	—	LCD drive voltage (mask ROM versions can incorporate dividing resistor (mask option.))	—	—
BIAS	—	Power supply for LCD drive	—	—
ANI0 to ANI7	Input	A/D converter analog input	Input	P10 to P17
AV _{REF}	Input	D/A converter analog output	—	—
AV _{DD}	—	A/D converter reference voltage input	—	—

(2) Pins other than port pins (2/2)

Pin Name	Input/Output	Function	After Reset	Alternative Function
AV _{SS}	—	A/D converter ground potential. Connect to V _{SS} .	—	—
$\overline{\text{RESET}}$	Input	System reset input	—	—
X1	Input	Crystal connection for main system clock oscillation	—	—
X2	—		—	—
XT1	Input	Crystal connection for subsystem clock oscillation	Input	P07
XT2	—		—	—
V _{DD}	—	Positive power supply	—	—
* V _{PP}	—	High-voltage application for program write/verify. Connect directly to V _{SS} in normal operating mode.	—	—
V _{SS}	—	Ground potential	—	—
IC	—	Internal connection. Connect directly to V _{SS} .	—	—

3.1.2 PROM programming mode pins (μ PD78P064 only)

Pin Name	Input/Output	Function
$\overline{\text{RESET}}$	Input	PROM programming mode setting. When +5 V or +12.5 V is applied to the V _{PP} pin or a low level voltage is applied to the RESET pin, the PROM programming mode is set.
V _{PP}	Input	High-voltage application for PROM programming mode setting and program write/verify.
A0 to A16	Input	Address bus
D0 to D7	Input/output	Data bus
$\overline{\text{CE}}$	Input	PROM enable input/program pulse input
$\overline{\text{OE}}$	Input	Read strobe input to PROM
$\overline{\text{PGM}}$	Input	Program/program inhibit input in PROM programming mode
V _{DD}	—	Positive power supply
V _{SS}	—	Ground potential

3.2 Description of Pin Functions

3.2.1 P00 to P05, P07 (Port 0)

These are 7-bit input/output ports. Besides serving as input/output ports, they function as an external interrupt input, an external count clock input to the timer, a capture trigger signal input, and crystal connection for subsystem clock oscillation.

The following operating modes can be specified bit-wise.

(1) Port mode

P00 and P07 function as input-only ports and P01 to P05 function as input/output ports.

P01 to P05 can be specified for input or output ports bit-wise with a port mode register 0. When they are used as input ports, pull-up resistors can be connected to them by defining the pull-up resistor option register L.

(2) Control mode

In this mode, these ports function as an external interrupt input, an external count clock input to the timer, and crystal connection for subsystem clock oscillation.

(a) INTPO to INTP5

INTP0 to INTP5 are external interrupt input pins which can specify valid edges (rising edge, falling edge, and both rising and falling edges). INTP0 or INTP1 becomes a 16-bit timer/event counter capture trigger signal input pin with a valid edge input.

(b) TI00

Pin for external count clock input to 16-bit timer/event counter

(c) TI01

Pin for capture trigger signal input to capture register (CR00) of 16-bit timer/event counter

(d) XT1

Crystal connect pin for subsystem clock oscillation

3.2.2 P10 to P17 (Port 1)

These are 8-bit input/output ports. Besides serving as input/output ports, they function as an A/D converter analog input.

The following operating modes can be specified bit-wise.

(1) Port mode

These ports function as 8-bit input/output ports.

They can be specified bit-wise as input or output ports with a port mode register 1. If used as input ports, pull-up resistors can be connected to these ports by defining the pull-up resistor option register L.

(2) Control mode

These ports function as A/D converter analog input pins (ANI0-ANI7). The pull-up resistor is automatically disabled when the pins specified for analog input.

3.2.3 P25 to P27 (Port 2)

These are 3-bit input/output ports. Besides serving as input/output ports, they function as data input/output to/from the serial interface and clock input/output.

The following operating modes can be specified bit-wise.

(1) Port mode

These ports function as 3-bit input/output ports. They can be specified bit-wise as input or output ports with port mode register 2. When they are used as input ports, pull-up resistors can be connected to them by defining the pull-up resistor option register L.

(2) Control mode

These ports function as serial interface data input/output and clock input/output.

(a) SI0, SO0

Serial interface serial data input/output pins

(b) $\overline{\text{SCK0}}$

Serial interface serial clock input/output pins

(c) SB0 and SB1

NEC standard serial bus interface input/output pins

Caution When this port is used as a serial interface, the I/O and output latches must be set according to the function the user requires. For the setting, refer to Figure 15-4 "Serial Operation Mode Register 0 Format".

3.2.4 P30 to P37 (Port 3)

These are 8-bit input/output ports. Beside serving as input/output ports, they function as timer input/output, clock output and buzzer output.

The following operating modes can be specified bit-wise.

(1) Port mode

These ports function as 8-bit input/output ports. They can be specified bit-wise as input or output ports with port mode register 3. When they are used as input ports, pull-up resistors can be connected by defining the pull-up resistor option register L.

(2) Control mode

These ports function as timer input/output, clock output, and buzzer output.

(a) T11 and T12

Pin for external clock input to the 8-bit timer/event counter.

(b) T00 to T02

Timer output pins.

(c) PCL

Clock output pin.

(d) BUZ

Buzzer output pin.

3.2.5 P70 to P72 (Port 7)

These are 3-bit input/output ports. Beside serving as input/output ports, they function as serial interface data input/output, clock input/output.

The following operating modes can be specified bit-wise.

(1) Port mode

These ports function as 3-bit input/output ports. They can be specified bit-wise as input or output ports with port mode register 7. When they are used as input ports, pull-up resistors can be connected by defining the pull-up resistor option register L.

(2) Control mode

These ports function as serial interface data input/output and clock input/output.

(a) SI2, SO2

Serial interface serial data input/output pins

(b) $\overline{\text{SCK2}}$

Serial interface serial clock input/output pin.

(c) RxD, TxD

Asynchronous serial interface serial data input/output pins.

(d) ASCK

Asynchronous serial interface serial clock input pin.

* **Caution** When this port is used as a serial interface, the I/O and output latches must be set according to the function the user requires.
For the setting, see the operation mode setting list in Table 17-2 "Serial Interface Channel 2".

3.2.6 P80-P87 (Port 8)

These are 8-bit input/output ports. Beside serving as input/output ports, they function as segment signal output of LCD controller/driver.

The following operating modes can be specified bit-wise.

(1) Port mode

These ports function as 8-bit input/output ports. They can be specified bit-wise as input/output ports with port mode register 8. When they are used as input ports, pull-up resistors can be connected by defining the pull-up resistor option register H.

(2) Control mode

These ports function as segment signal output pins (S32 to S39) of LCD controller/driver.

www.DataSheet4U.com

3.2.7 P90-P97 (Port 9)

These are 8-bit input/output ports. Beside serving as input/output ports, they function as segment signal output of LCD controller/driver.

The following operating modes can be specified bit-wise.

(1) Port mode

These ports function as 8-bit input/output ports. They can be specified bit-wise as input/output ports with port mode register 9. When they are used as input ports, pull-up resistors can be connected by defining the pull-up resistor option register H.

(2) Control mode

These ports function as segment signal/output pins (S24 to S31) of LCD controller/driver.

3.2.8 P100-P103 (Port 10)

These ports function as 4-bit input/output ports. They can be specified bit-wise as input/output ports with port mode register 10. When they are used as input ports, pull-up resistors can be connected by defining the pull-up resistor option register H.

LED can be driven directly.

3.2.9 P110-P117 (Port 11)

These ports function as 8-bit input/output ports. They can be specified bit-wise as input/output ports with port mode register 11. When they are used as input ports, pull-up resistors can be connected by defining the pull-up resistor option register H.

Test input flag (KRIF) can be set to 1 by detecting falling edges.

3.2.10 COM0 to COM3

These are LCD controller/driver common signal output pins. They output common signals under either of the following conditions:

- when the static mode is selected (COM0 to COM3 outputs)
- when 2-time-division (COM0, COM1 outputs) or 3-time-division (COM0 to COM2 outputs) operation is performed in 1/2 bias mode
- when 3-time-division (COM0 to COM2 outputs) or 4-time-division (COM0 to COM3 outputs) operation is performed in 1/3 bias mode

3.2.11 VLc0-VLc2

These are LCD-driving voltage pins. The mask ROM versions can have split resistors by mask option so that LCD driving voltage can be supplied inside the VLc0-VLc2 pins according to the required bias without connecting external split resistors.

3.2.12 BIAS

These are LCD driving power supply pins. They should be connected to the VLc0 pin to realize user-desired LCD drive voltages to change resistance division ratios, or should be connected to external resistors together with the VLc0-VLc2 pins and Vss pin to fine-adjust the LCD-driving power voltage.

3.2.13 AVREF

This pin inputs the reference voltage for the on-chip A/D converter.
When not using the A/D converter, connect this pin to the Vss line.

3.2.14 AVDD

This pin supplies analog voltage for the on-chip A/D converter. Even when not using the A/D converter, always use this pin at the same voltage as VDD.

3.2.15 AVSS

This is a ground voltage pin of A/D converter. Always use the same voltage as that of the Vss pin even when A/D converter is not used.

3.2.16 RESET

This is a low-level active system reset input pin.

3.2.17 X1 and X2

Crystal resonator connect pins for main system clock oscillation. For external clock supply, input it to X1 and its inverted signal to X2.

3.2.18 XT1 and XT2

Crystal resonator connect pins for subsystem clock oscillation.
For external clock supply, input it to XT1 and its inverted signal to XT2.

3.2.19 V_{DD}

Positive power supply pin

3.2.20 V_{SS}

Ground potential pin

3.2.21 V_{PP} (μ PD78P064 only)

High-voltage apply pin for PROM programming mode setting and program write/verify.

Connect directly to V_{SS} in normal operating mode.

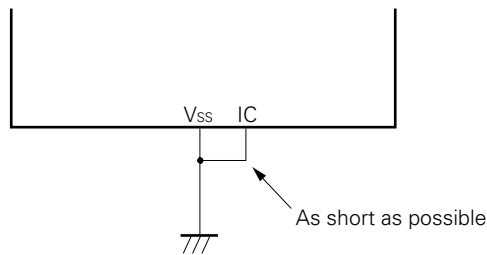
3.2.22 IC (Mask ROM version only)

The IC (Internally Connected) pin is provided to set the test mode to check the μ PD78064 subseries at delivery.

Connect it directly to the V_{SS} with the shortest possible wire in the normal operating mode.

When a voltage difference is produced between the IC pin and V_{SS} pin because the wiring between those two pins is too long or an external noise is input to the IC pin, the user's program may not run normally.

- **Connect IC pins to V_{SS} pins directly.**



3.3 Input/output Circuits and Recommended Connection of Unused Pins

Table 3-1 shows the input/output circuit types of pins and the recommended conditions for unused pins. Refer to Figure 3-1 for the configuration of the input/output circuit of each type.

Table 3-1. Pin Input/Output Circuit Types (1/2)

Pin Name	Input/Output Circuit Type	Input/Output	Recommended Connection of Unused Pins	
P00/INTP0/TI00	2	Input	Connect to V _{SS} .	
P01/INTP1/TI01	8-A	Input/Output	Connect independently via a resistor to V _{SS} .	
P02/INTP2				
P03/INTP3				
P04/INTP4				
P05/INTP5				
P07/XT1	16	Input	Connect to V _{DD} .	
P10/ANI0 to P17/ANI7	11	Input/Output	Connect independently via a resistor to V _{DD} or V _{SS} .	
P25/SI0/SB0	10-A			
P26/SO0/SB1				
P27/ $\overline{\text{SCK0}}$				
P30/TO0	5-A			
P31/TO1				
P32/TO2				
P33/TI1	8-A			
P34/TI2				
P35/PCL	5-A			
P36/BUZ				
P37				
P70/SI2/RxD	8-A			
P71/SO2/TxD	5-A			
P72/ $\overline{\text{SCK2}}$ /ASCK	8-A			
P80/S39-P87/S32	17-A			
P90/S31-P97/S24				
P100-P103	5-A			
P110-P117	8-A			Connect to V _{SS} .
S0-S23	17			Output
COM0-COM3	18			
V _{LC0} -V _{LC2}	—	—	Open	
BIAS	—	—		
$\overline{\text{RESET}}$	2	Input		
XT2	16	—	Open	

*

*

Table 3-1. Pin Input/Output Circuit Types (2/2)

Pin Name	Input/Output Circuit Type	Input/Output	Recommended Connection of Unused Pins
AV_{REF}	—	—	Connect to V_{SS} .
AV_{DD}			Connect to V_{DD} .
AV_{SS}			Connect to V_{SS} .
IC (Mask ROM version)			Connect directly to V_{SS} .
V_{PP} (μ PD78P064 version)			

*

Figure 3-1. Pin Input/Output Circuit of List (1/2)

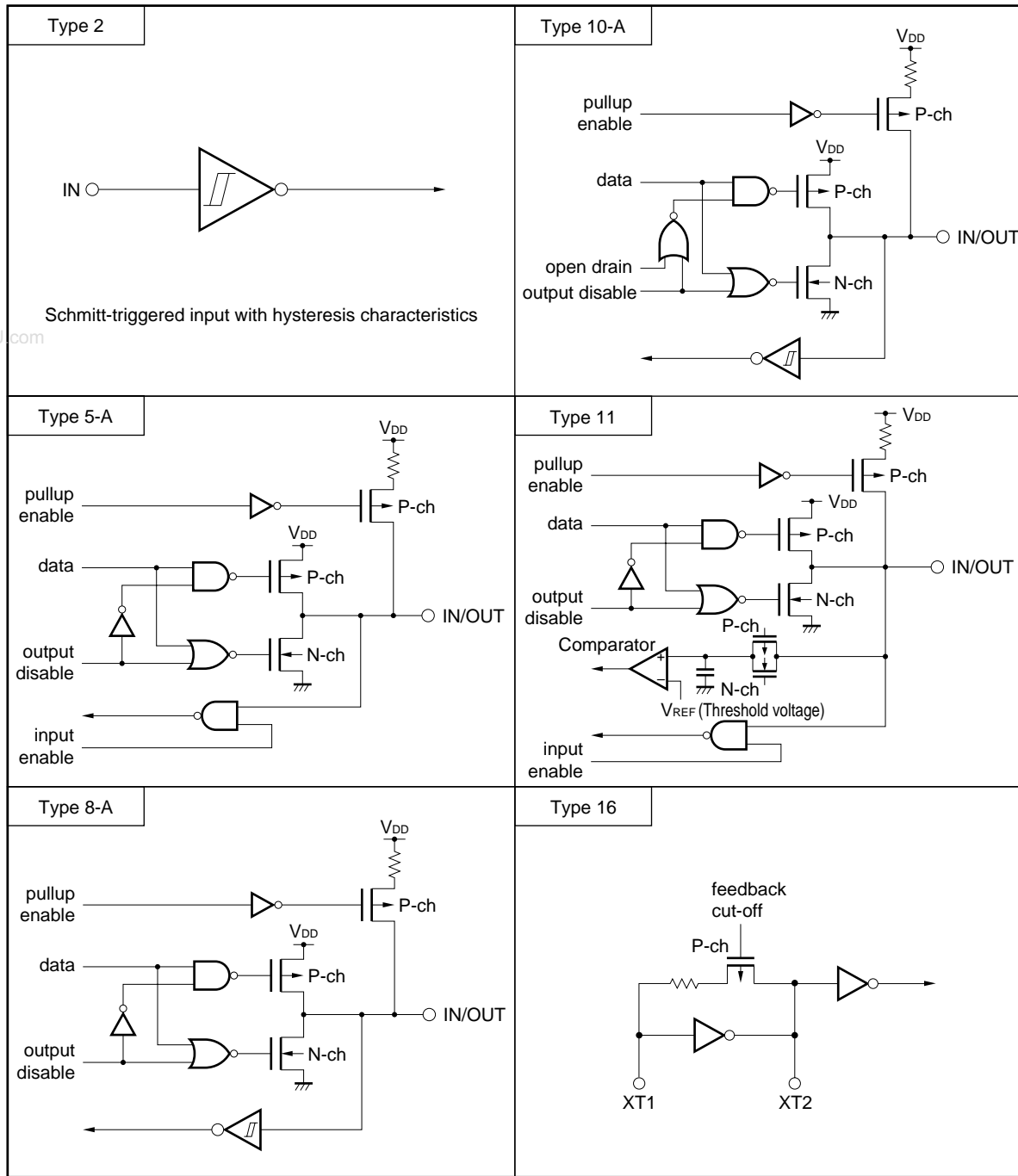
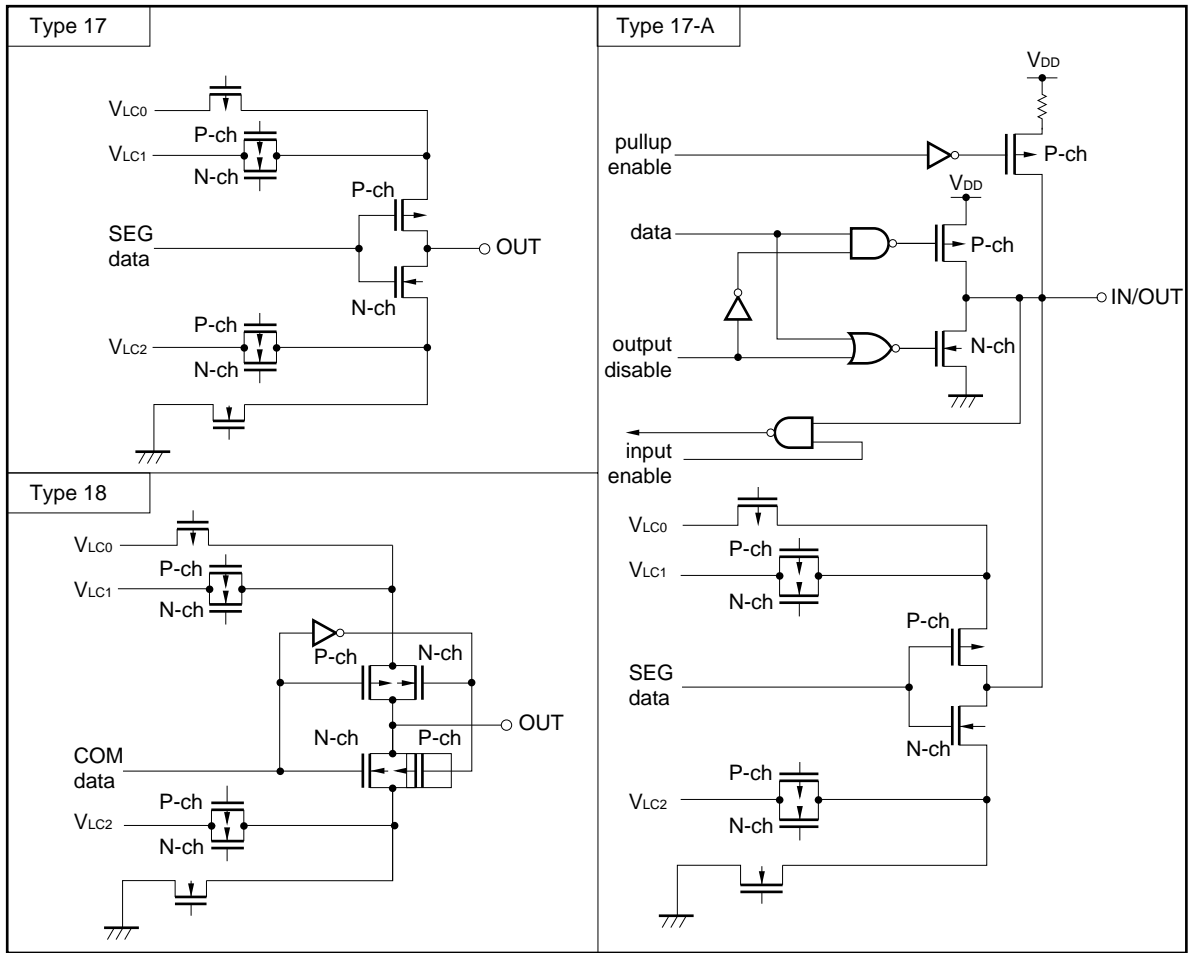


Figure 3-1. Pin Input/Output Circuit of List (2/2)



www.DataSheet4U.com

[MEMO]

www.DataSheet4U.com

4.1 Pin Function List

4.1.1 Normal operating mode pins

(1) Port pins (1/2)

Pin Name	Input/Output	Function		After Reset	Alternative Function
P00	Input	Port 0.	Input only	Input	INTP0/TI00
P01	Input/	7-bit input/output port. Input/output mode can be specified bit-wise. If used as an input port, a pull-up resistor can be connected by software.		Input	INTP1/TI01
P02	output				INTP2
P03					INTP3
P04					INTP4
P05					INTP5
P07 ^{Note1}	Input		Input only	Input	XT1
P10 to P17	Input/ output	Port 1. 8-bit input/output port. Input/output mode can be specified bit-wise. If used as input port, a pull-up resistor can be connected by software ^{Note2} .		Input	ANI0 to ANI7
P25	Input	Port 2.	3-bit input/output port. Input/output mode can be specified bit-wise. If used as an input port, a pull-up resistor can be connected by software.	Input	SI0/SB0/SDA0
P26	output/				SO0/SB1/SDA1
P27					$\overline{\text{SCK0}}$ /SCL
P30	Input/	Port 3.	8-bit input/output port. Input/output mode can be specified bit-wise. If used as an input port, a pull-up resistor can be connected by software.	Input	TO0
P31	output				TO1
P32					TO2
P33					TI1
P34					TI2
P35					PCL
P36					BUZ
P37					—

- Notes**
1. When the P07/XT1 pin is used as an input port, set the bit 6 (FRC) of the processor clock control register to 1 (do not use the feedback resistor internal to the subsystem clock oscillator).
 2. When pins P10/ANI0 to P17/ANI7 are used as an analog input of the A/D converter, the pull-up resistor is automatically disabled.

(1) Port pins (2/2)

Pin Name	Input/Output	Function	After Reset	Alternative Function
P70	Input/ output	Port 7.	Input	SI2/RxD
P71		3-bit input/output port.		SO2/TxD
P72		Input/output mode can be specified bit-wise. If used as an input port, a pull-up resistor can be connected by software.		$\overline{\text{SCK2/ASCK}}$
P80 to P87	Input/ output	Port 8. 8-bit input/output port. Input/output mode can be specified bit-wise. If used as an input port, a pull-up resistor can be connected by software. I/O port / segment signal output can be specified in 2-bit units by LCD control register.	Input	S39 to S32
P90 to P97	Input/ output	Port 9. 8-bit input/output port. Input/output mode can be specified bit-wise. If used as an input port, a pull-up resistor can be connected by software. I/O port / segment signal output can be specified in 2-bit units by LCD control register.	Input	S31 to S24
P100 to P103	Input/ output	Port 10. 4-bit input/output port. Input/output mode can be specified bit-wise. If used as an input port, a pull-up resistor can be connected by software. A resistor can be connected. LED can be driven directly.	Input	—
P110 to 117	Input/ Output	Port 11. 8-bit input/output port. Input/output mode can be specified bit-wise. If used as an input port, a pull-up resistor can be connected by software. Falling edge can be detected.	Input	—

(2) Pins other than port pins (1/2)

Pin Name	Input/Output	Function	After Reset	Alternative Function
INTP0	Input	External interrupt inputs with specifiable valid edges (rising edge, falling edge, both rising and falling edges).	Input	P00/TI00
INTP1				P01/TI01
INTP2				P02
INTP3				P03
INTP4				P04
INTP5				P05
SI0	Input	Serial interface serial data input	Input	P25/SB0/SDA0
SI2				P70/RxD
SO0	Output	Serial interface serial data output	Input	P26/SB1/SDA1
SO2				P71/TxD
SB0	Input/ output	Serial interface serial data input/output	Input	P25/SI0/SDA0
SB1				P26/SO0/SDA1
SDA0				P25/SI0/SB0
SDA1				P26/SO0/SB1
$\overline{\text{SCK0}}$	Input/ output	Serial interface serial clock input/output	Input	P27/SCL
$\overline{\text{SCK2}}$				P72/ASCK
SCL				P27/ $\overline{\text{SCK0}}$
RxD	Input	Asynchronous serial interface serial data input	Input	P70/SI2
TxD	Output	Asynchronous serial interface serial data output	Input	P71/SO2
ASCK	Input	Asynchronous serial interface serial clock input	Input	P72/ $\overline{\text{SCK2}}$
TI00	Input	External count clock input to 16-bit timer (TM0)	Input	P00/INTP0
TI01		Capture trigger signal input to capture register (CR00)		P01/INTP1
TI1		External count clock input to 8-bit timer (TM1)		P33
TI2		External count clock input to 8-bit timer (TM2)		P34
TO0	Output	16-bit timer output (also used for 14-bit PWM output)	Input	P30
TO1		8-bit timer output		P31
TO2				P32
PCL	Output	Clock output (for main system clock and subsystem clock trimming)	Input	P35
BUZ	Output	Buzzer output	Input	P36
S0 to S23	Output	Segment signal output of LCD controller/driver	Output	—
S24 to S31			Input	P97 to P90
S32 to S39				P87 to P80
COM0 to COM3	Output	Common signal output of LCD controller/driver	Output	—
V _{LC0} to V _{LC2}	—	LCD drive voltage (mask ROM versions can incorporate dividing resistor (mask option).)	—	—
BIAS	—	Power supply for LCD drive	—	—
ANI0 to ANI7	Input	A/D converter analog input	Input	P10 to P17
AV _{REF}	Input	A/D converter analog output	—	—
AV _{DD}	—	A/D converter reference voltage input	—	—

(2) Pins other than port pins (2/2)

Pin Name	Input/Output	Function	After Reset	Alternative Function
AV _{SS}	—	A/D converter ground potential. Connect to V _{SS} .	—	—
RESET	Input	System reset input	—	—
X1	Input	Crystal connection for main system clock oscillation	—	—
X2	—		—	—
XT1	Input	Crystal connection for subsystem clock oscillation	Input	P07
XT2	—		—	—
V _{DD}	—	Positive power supply	—	—
V _{PP}	—	High-voltage application for program write/verify. Connect directly to V _{SS} in normal operating mode.	—	—
V _{SS}	—	Ground potential	—	—
IC	—	Internal connection. Connect directly to V _{SS} .	—	—

4.1.2 PROM programming mode pins (μ PD78P064Y only)

Pin Name	Input/Output	Function
RESET	Input	PROM programming mode setting. When +5 V or +12.5 V is applied to the V _{PP} pin or a low level voltage is applied to the RESET pin, the PROM programming mode is set.
V _{PP}	Input	High-voltage application for PROM programming mode setting and program write/verify.
A0 to A16	Input	Address bus
D0 to D7	Input/output	Data bus
CE	Input	PROM enable input/program pulse input
OE	Input	Read strobe input to PROM
PGM	Input	Program/program inhibit input in PROM programming mode
V _{DD}	—	Positive power supply
V _{SS}	—	Ground potential

4.2 Description of Pin Functions

4.2.1 P00 to P05, P07 (Port 0)

These are 7-bit input/output ports. Besides serving as input/output ports, they function as an external interrupt input, an external count clock input to the timer, a capture trigger signal input, and crystal connection for subsystem clock oscillation.

The following operating modes can be specified bit-wise.

(1) Port mode

P00 and P07 function as input-only ports and P01 to P05 function as input/output ports.

P01 to P05 can be specified for input or output ports bit-wise with a port mode register 0. When they are used as input ports, pull-up resistors can be connected to them by defining the pull-up resistor option register L.

(2) Control mode

In this mode, these ports function as an external interrupt input, an external count clock input to the timer, and crystal connection for subsystem clock oscillation.

(a) INTP0 to INTP5

INTP0 to INTP5 are external interrupt input pins which can specify valid edges (rising edge, falling edge, and both rising and falling edges). INTP0 or INTP1 becomes a 16-bit timer/event counter capture trigger signal input pin with a valid edge input.

(b) TI00

Pin for external count clock input to 16-bit timer/event counter

(c) TI01

Pin for capture trigger signal input to capture register (CR00) of 16-bit timer/event counter

(d) XT1

Crystal connect pin for subsystem clock oscillation

4.2.2 P10 to P17 (Port 1)

These are 8-bit input/output ports. Besides serving as input/output ports, they function as an A/D converter analog input.

The following operating modes can be specified bit-wise.

(1) Port mode

These ports function as 8-bit input/output ports.

They can be specified bit-wise as input or output ports with a port mode register 1. If used as input ports, pull-up resistors can be connected to these ports by defining the pull-up resistor option register L.

(2) Control mode

These ports function as A/D converter analog input pins (ANI0-ANI7). The pull-up resistor is automatically disabled when the pins specified for analog input.

4.2.3 P25 to P27 (Port 2)

These are 3-bit input/output ports. Besides serving as input/output ports, they function as data input/output to/from the serial interface and clock input/output.

The following operating modes can be specified bit-wise.

(1) Port mode

These ports function as 3-bit input/output ports. They can be specified bit-wise as input or output ports with port mode register 2. When they are used as input ports, pull-up resistors can be connected to them by defining the pull-up resistor option register L.

(2) Control mode

These ports function as serial interface data input/output and clock input/output.

(a) SI0, SO0, SB0, SB1, SDA0, SDA1

Serial interface serial data input/output pins

(b) $\overline{\text{SCK0}}$, SCL

Serial interface serial clock input/output pins

Caution When this port is used as a serial interface, the I/O and output latches must be set according to the function the user requires. For the setting, refer to Figure 16-4 "Serial Operation Mode Register 0 Format".

4.2.4 P30 to P37 (Port 3)

These are 8-bit input/output ports. Beside serving as input/output ports, they function as timer input/output, clock output and buzzer output.

The following operating modes can be specified bit-wise.

(1) Port mode

These ports function as 8-bit input/output ports. They can be specified bit-wise as input or output ports with port mode register 3. When they are used as input ports, pull-up resistors can be connected by defining the pull-up resistor option register L.

(2) Control mode

These ports function as timer input/output, clock output, and buzzer output.

(a) T11 and T12

Pin for external clock input to the 8-bit timer/event counter.

(b) T00 to T02

Timer output pins.

(c) PCL

Clock output pin.

(d) BUZ

Buzzer output pin.

4.2.5 P70 to P72 (Port 7)

These are 3-bit input/output ports. Beside serving as input/output ports, they function as serial interface data input/output, clock input/output.

The following operating modes can be specified bit-wise.

(1) Port mode

These ports function as 3-bit input/output ports. They can be specified bit-wise as input or output ports with port mode register 7. When they are used as input ports, pull-up resistors can be connected by defining the pull-up resistor option register L.

(2) Control mode

These ports function as serial interface data input/output and clock input/output.

(a) SI2, SO2

Serial interface serial data input/output pins

(b) $\overline{\text{SCK2}}$

Serial interface serial clock input/output pin.

(c) RxD, TxD

Asynchronous serial interface serial data input/output pins.

(d) ASCK

Asynchronous serial interface serial clock input pin.

Caution When this port is used as a serial interface, the I/O and output latches must be set according to the function the user requires.

For the setting, see the operation mode setting list in Table 17-2 "Serial Interface Channel 2"

4.2.6 P80-P87 (Port 8)

These are 8-bit input/output ports. Beside serving as input/output ports, they function as segment signal output of LCD controller/driver.

The following operating modes can be specified bit-wise.

(1) Port mode

These ports function as 8-bit input/output ports. They can be specified bit-wise as input/output ports with port mode register 8. When they are used as input ports, pull-up resistors can be connected by defining the pull-up resistor option register H.

(2) Control mode

These ports function as segment signal output pins (S32 to S39) of LCD controller/driver.

www.DataSheet4U.com

4.2.7 P90-P97 (Port 9)

These are 8-bit input/output ports. Beside serving as input/output ports, they function as segment signal output of LCD controller/driver.

The following operating modes can be specified bit-wise.

(1) Port mode

These ports function as 8-bit input/output ports. They can be specified bit-wise as input/output ports with port mode register 9. When they are used as input ports, pull-up resistors can be connected by defining the pull-up resistor option register H.

(2) Control mode

These ports function as segment signal output pins (S24 to S31) of LCD controller/driver.

4.2.8 P100-P103 (Port 10)

These are 4-bit input/output ports. They can be specified bit-wise as input/output ports with port mode register 10. When they are used as input ports, pull-up resistors can be connected by defining the pull-up resistor option register H.

LED can be driven directly.

4.2.9 P110-P117 (Port 11)

These are 8-bit input/output ports. They can be specified bit-wise as input/output ports with port mode register 11. When they are used as input ports, pull-up resistors can be connected by defining the pull-up resistor option register H.

Test input flag (KRIF) can be set to 1 by detecting falling edges.

4.2.10 COM0 to COM3

These are LCD controller/driver common signal output pins. They output common signals under either of the following conditions:

- when the static mode is selected (COM0 to COM3 outputs)
- when 2-time-division (COM0, COM1 outputs) or 3-time-division (COM0 to COM2 outputs) operation is performed in 1/2 bias mode
- when 3-time-division (COM0 to COM2 outputs) or 4-time-division (COM0 to COM3 outputs) operation is performed in 1/3 bias mode

4.2.11 VLCO-VLC2

These are LCD-driving voltage pins. The mask ROM versions can have split resistors by mask option so that LCD driving voltage can be supplied inside the VLCO-VLC2 pins according to the required bias without connecting external split resistors.

4.2.12 BIAS

These are LCD driving power supply pins. They should be connected to the VLCO pin to realize user-desired LCD drive voltages to change resistance division ratios, or should be connected to external resistors together with the VLCO-VLC2 pins and VSS pin to fine-adjust the LCD-driving power voltage.

4.2.13 AVREF

This pin inputs the reference voltage for the on-chip A/D converter.
When not using the A/D converter, connect this pin to the VSS line.

4.2.14 AVDD

This pin supplies analog voltage for the on-chip A/D converter. Even when not using the A/D converter, always use this pin at the same voltage as VDD.

4.2.15 AVSS

This is a ground voltage pin of A/D converter. Always use the same voltage as that of the VSS pin even when A/D converter is not used.

4.2.16 RESET

This is a low-level active system reset input pin.

4.2.17 X1 and X2

Crystal resonator connect pins for main system clock oscillation. For external clock supply, input it to X1 and its inverted signal to X2.

4.2.18 XT1 and XT2

Crystal resonator connect pins for subsystem clock oscillation.
For external clock supply, input it to XT1 and its inverted signal to XT2.

4.2.19 V_{DD}

Positive power supply pin

4.2.20 V_{SS}

Ground potential pin

4.2.21 V_{PP} (μ PD78P064Y only)

High-voltage apply pin for PROM programming mode setting and program write/verify.

Connect directly to V_{SS} in normal operating mode.

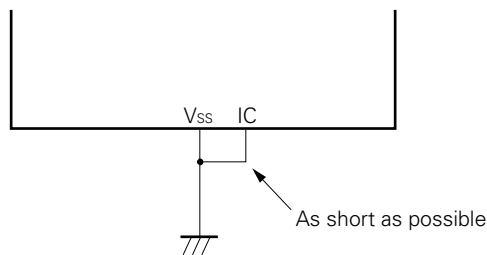
4.2.22 IC (Mask ROM version only)

The IC (Internally Connected) pin is provided to set the test mode to check the μ PD78064Y subseries at delivery.

Connect it directly to the V_{SS} with the shortest possible wire in the normal operating mode.

When a voltage difference is produced between the IC pin and V_{SS} pin because the wiring between those two pins is too long or an external noise is input to the IC pin, the user's program may not run normally.

- **Connect IC pins to V_{SS} pins directly.**



4.3 Input/output Circuits and Recommended Connection of Unused Pins

Table 4-1 shows the input/output circuit types of pins and the recommended conditions for unused pins. Refer to Figure 4-1 for the configuration of the input/output circuit of each type.

Table 4-1. Pin Input/Output Circuit Types (1/2)

Pin Name	Input/Output Circuit Type	Input/Output	Recommended Connection of Unused Pins	
P00/INTP0/TI00	2	Input	Connect to V _{SS} .	
P01/INTP1/TI01	8-A	Input/Output	Connect independently via a resistor to V _{SS} .	
P02/INTP2				
P03/INTP3				
P04/INTP4				
P05/INTP5				
P07/XT1	16	Input	Connect to V _{DD} .	
P10/ANI0 to P17/ANI7	11	Input/Output	Connect independently via a resistor to V _{DD} or V _{SS} .	
P25/SI0/SB0/SDA0	10-A			
P26/SO0/SB1/SDA1				
P27/ $\overline{\text{SCK0}}$ /SCL				
P30/TO0				
P31/TO1	5-A			
P32/TO2				
P33/TI1				
P34/TI2	8-A			
P35/PCL				
P36/BUZ	5-A			
P37				
P70/SI2/RxD				
P71/SO2/TxD	8-A			
P72/ $\overline{\text{SCK2}}$ /ASCK	5-A			
P80/S39-P87/S32	8-A			
P90/S31-P97/S24				
P100-P103	17-A			
P110-P117	5-A			Connect independently via a resistor to V _{DD} .
S0-S23	8-A			Output
COM0-COM3	17			
V _{LC0} -V _{LC2}	18			
BIAS	—			
$\overline{\text{RESET}}$	—			
XT2	2	Input	—	
	16	—	Open	

*

Table 4-1. Pin Input/Output Circuit Types (2/2)

Pin Name	Input/Output Circuit Type	Input/Output	Recommended Connection of Unused Pins
AV_{REF}	—	—	Connect to V_{SS} .
AV_{DD}			Connect to V_{DD} .
AV_{SS}			Connect to V_{SS} .
IC (Mask ROM version)			Connect directly to V_{SS} .
V_{PP} (μ PD78P064Y version)			

Figure 4-1. Pin Input/Output Circuit of List (1/2)

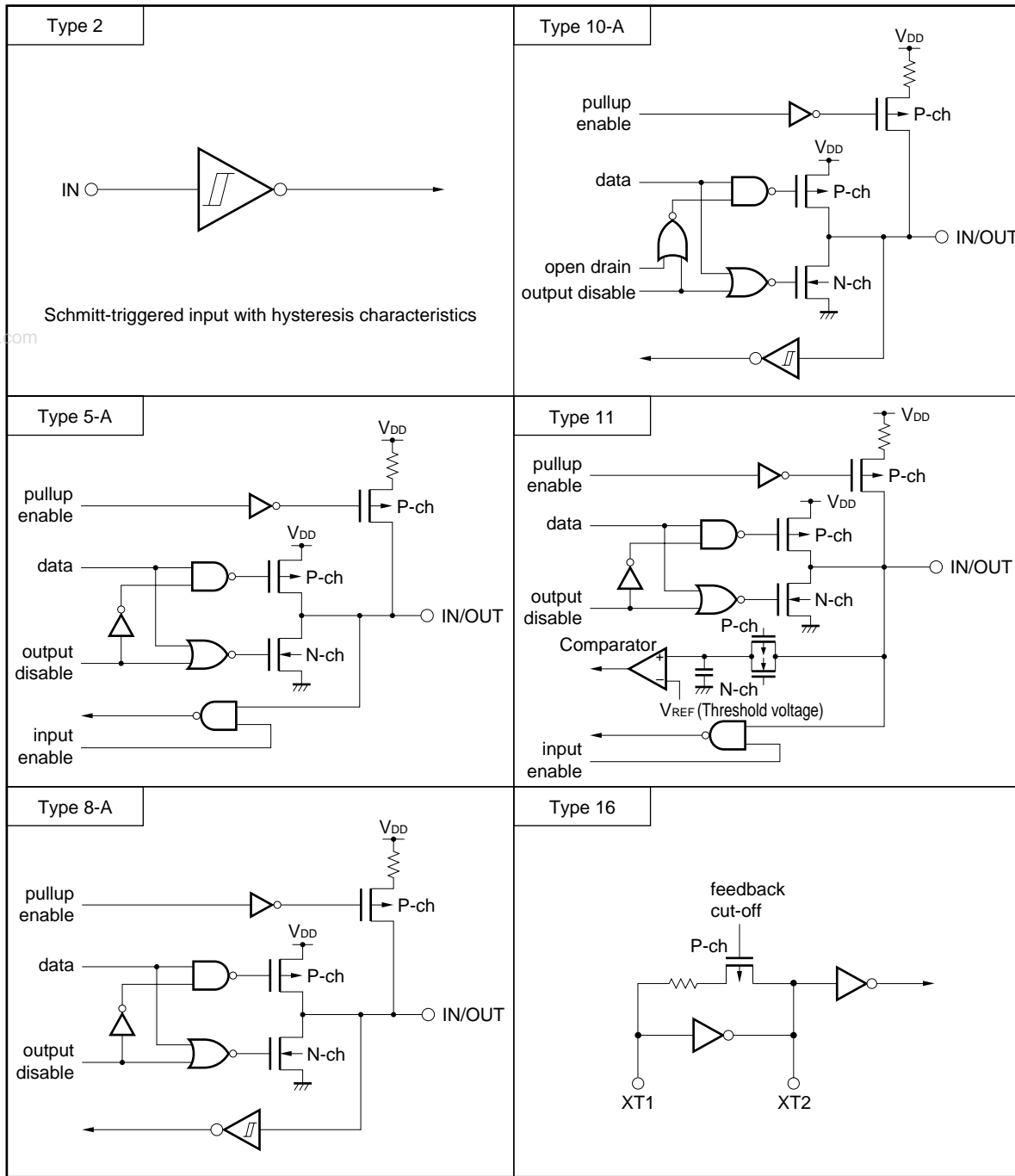
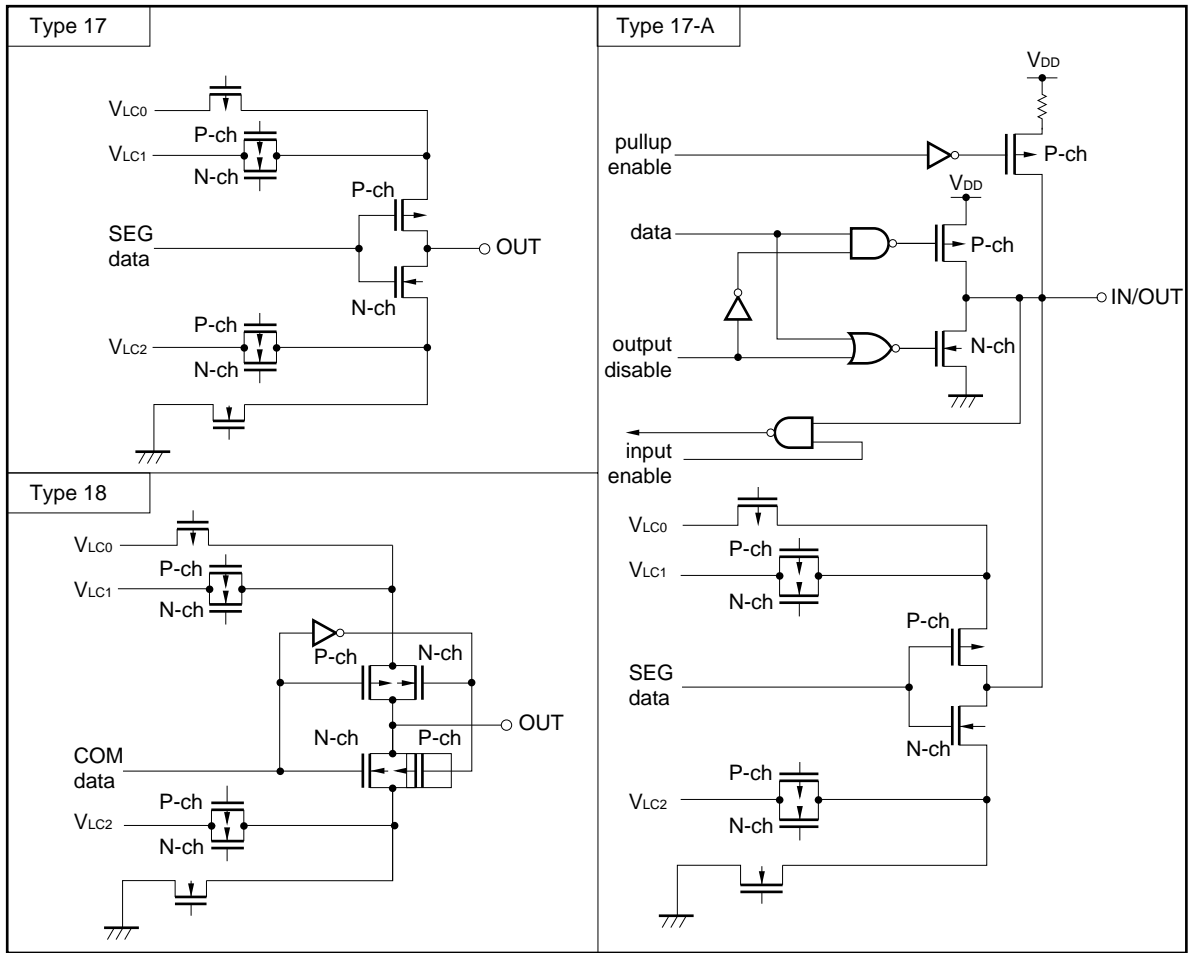


Figure 4-1. Pin Input/Output Circuit of List (2/2)



www.DataSheet4U.com

[MEMO]

www.DataSheet4U.com

CHAPTER 5 CPU ARCHITECTURE

5.1 Memory Spaces

Figures 5-1 to 5-4 shows memory maps.

Figure 5-1. Memory Map (μ PD78062, 78062Y)

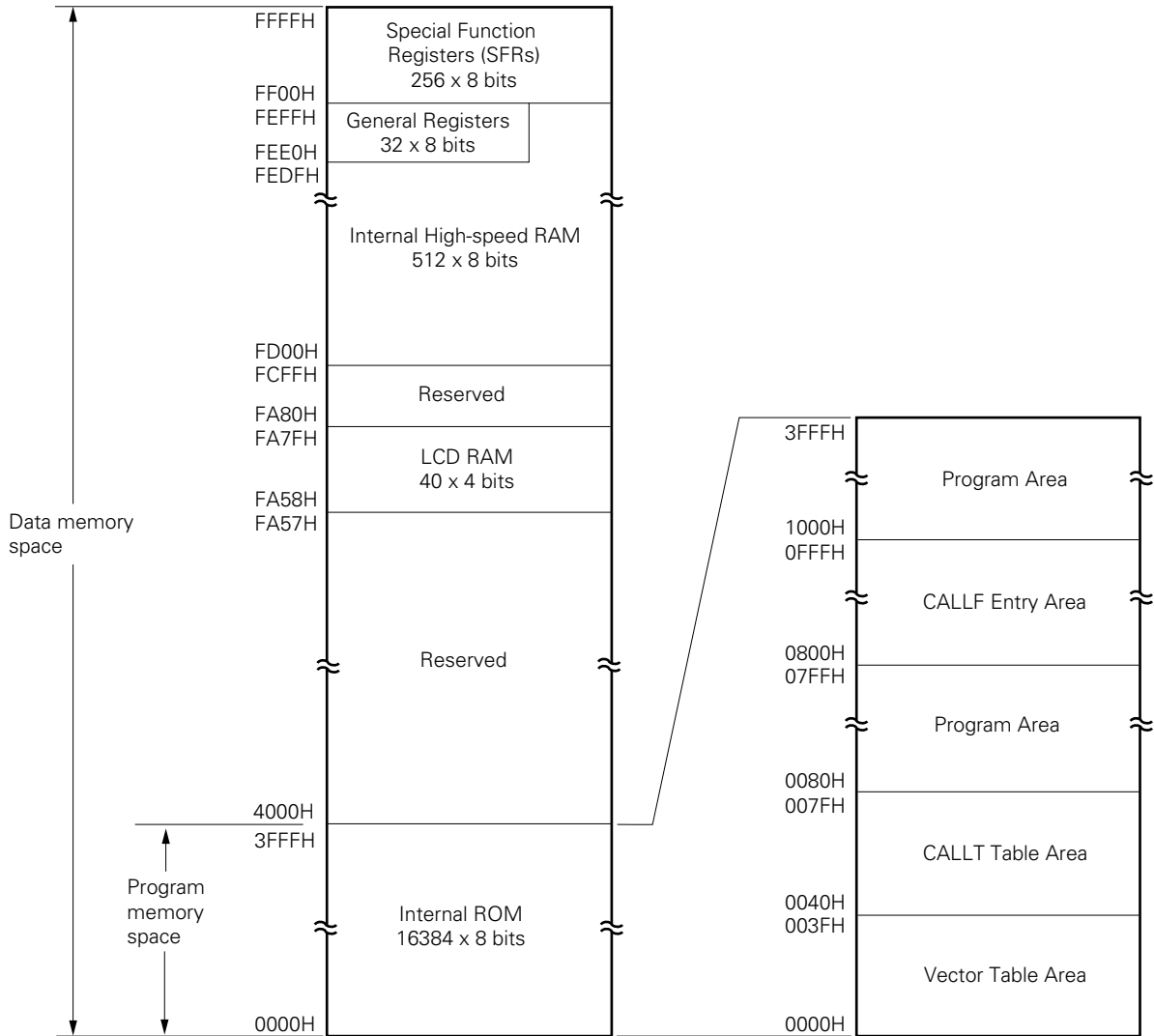


Figure 5-2. Memory Map (μ PD78063, 78063Y)

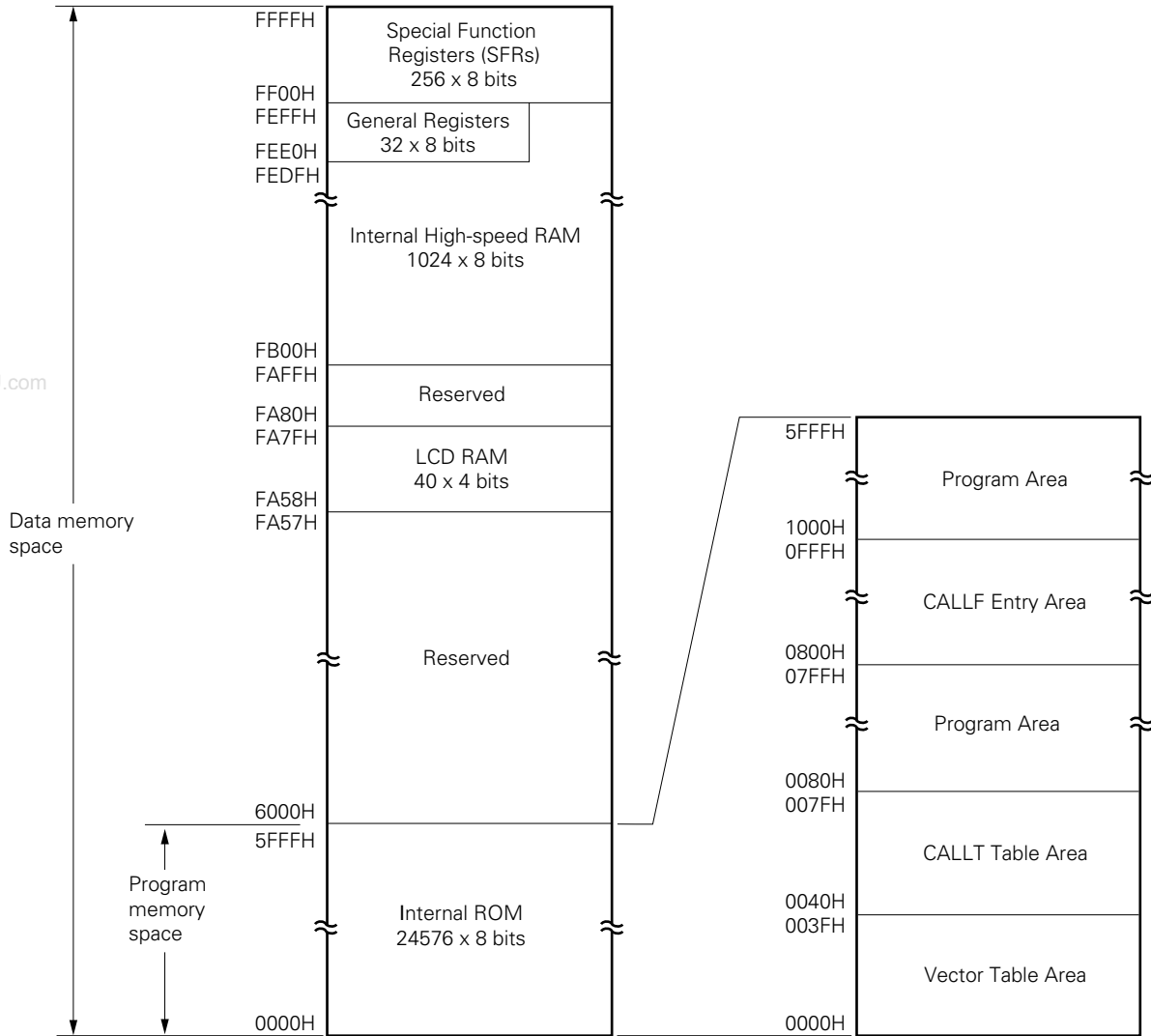
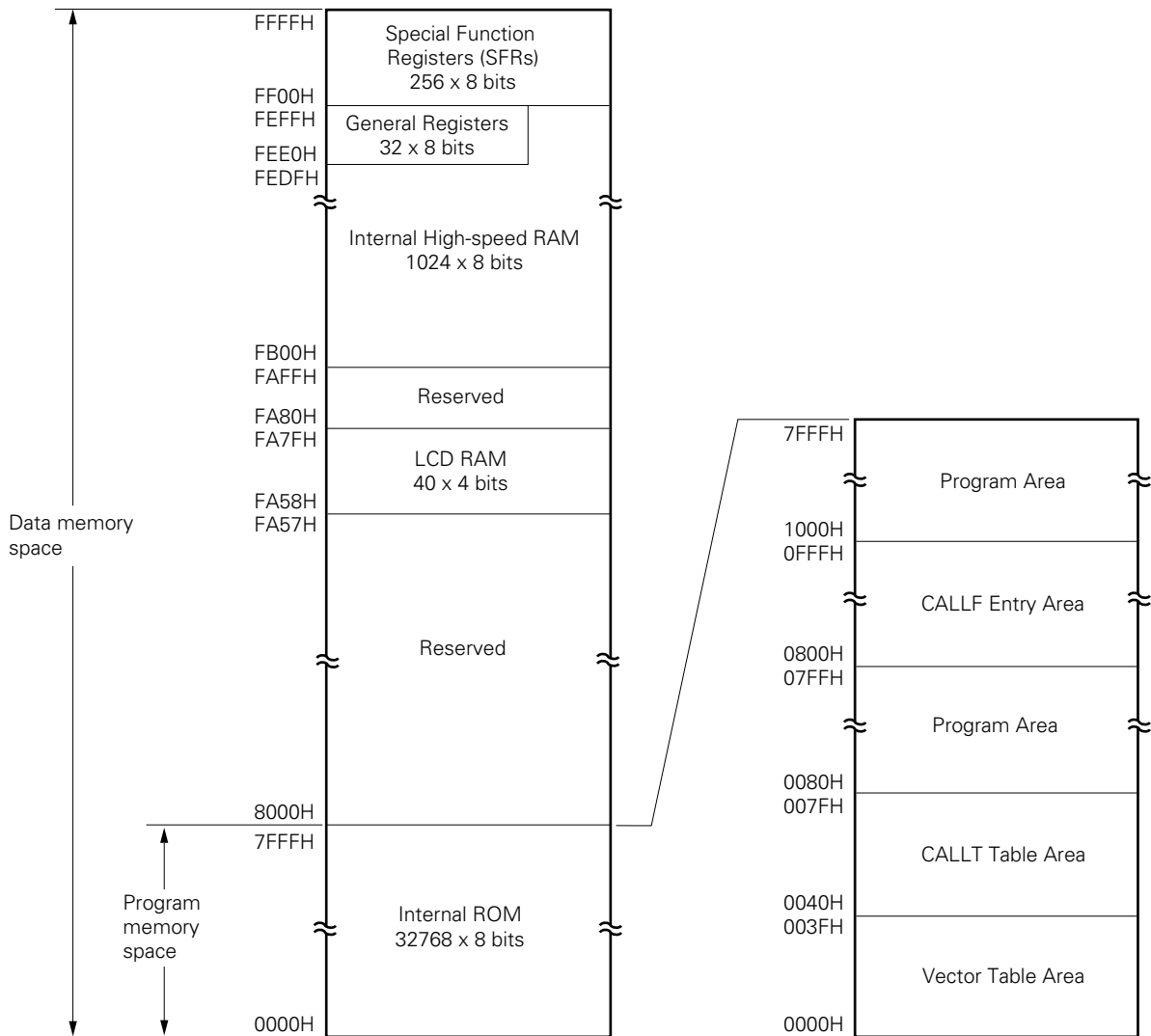
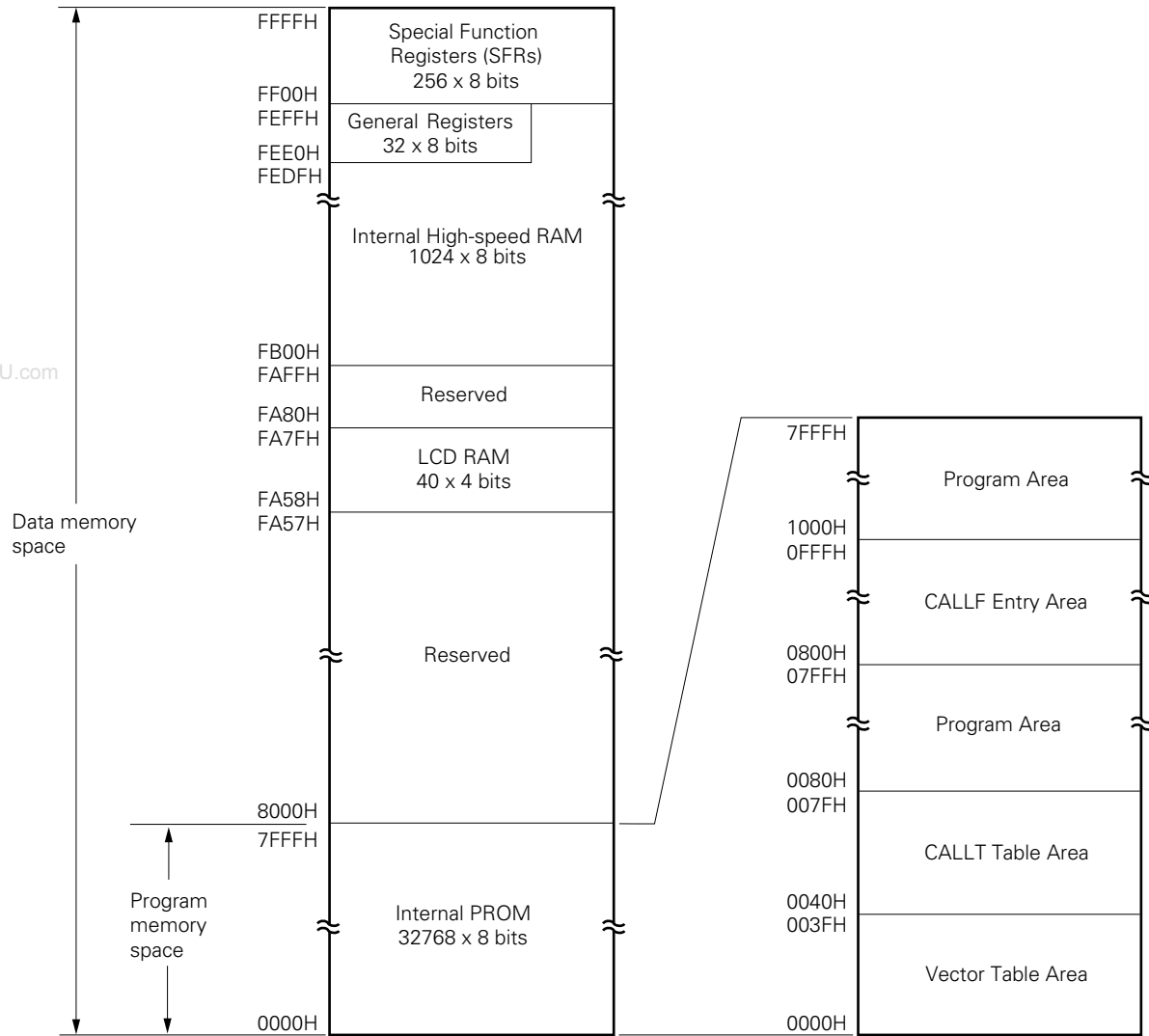


Figure 5-3. Memory Map (μ PD78064, 78064Y)



www.DataSheet4U.com

Figure 5-4. Memory Map (μ PD78P064, 78P064Y)



5.1.1 Internal program memory space

The internal program memory space stores program data and table data. This space is generally accessed with program counter (PC).

The μ PD78064, 78064Y subseries has on chip ROM (or PROM) and the capacity of the memory varies depending on the part number.

Table 5-1. Internal ROM Capacity

Part number	Internal ROM	
	Type	Capacity
μ PD78062, 78062Y	Mask ROM	16384 x 8 bits
μ PD78063, 78063Y		24576 x 8 bits
μ PD78064, 78064Y		32768 x 8 bits
μ PD78P064, 78P064Y	PROM	

The internal program memory is divided into the following three areas.

(1) Vector table area

The 64-byte area 0000H to 003FH is reserved as a vector table area. The $\overline{\text{RESET}}$ input and program start addresses for branch upon generation of each interrupt request are stored in the vector table area. Of the 16-bit address, low-order 8 bits are stored at even addresses and high-order 8 bits are stored at odd addresses.

Table 5-2. Vector Table

Vector Table Address	Interrupt Request
0000H	$\overline{\text{RESET}}$ input
0004H	INTWDT
0006H	INTP0
0008H	INTP1
000AH	INTP2
000CH	INTP3
000EH	INTP4
0010H	INTP5
0014H	INTCSI0
0018H	INTSER
001AH	INTSR/INTCSI2
001CH	INTST
001EH	INTTM3
0020H	INTTM00
0022H	INTTM01
0024H	INTTM1
0026H	INTTM2
0028H	INTAD
003EH	BRK

(2) CALLT instruction table area

The 64-byte area 0040H to 007FH can store the subroutine entry address of a 1-byte call instruction (CALLT).

(3) CALLF instruction entry area

The area 0800H to 0FFFH can perform a direct subroutine call with a 2-byte call instruction (CALLF).

5.1.2 Internal data memory space

The μ PD78064 and 78064Y subseries units incorporate the following RAMs.

(1) Internal high-speed RAM

The μ PD78064, 78064Y subseries has on-chip high-speed RAM, and the memory capacity varies depending on the part number as shown below.

www.DataSheet4U.com

Table 5-3. Internal High-Speed RAM Capacity

Part number	Internal high-speed RAM capacity
μ PD78062, 78062Y	512 x 8 bits
μ PD78063, 78063Y	1024 x 8 bits
μ PD78064, 78064Y	
μ PD78P064, 78P064Y	

In this area, four banks of general registers, each bank consisting of eight 8-bit registers, are allocated in the 32-byte area FEE0H to FEFFH.

The internal high-speed RAM can also be used as a stack.

(2) LCD display RAM

Addresses FA58H to FA7FH of 40 x 4 bits are allocated for LCD display RAM, However, this area can also be used as general-purpose RAM.

5.1.3 Special Function Register (SFR) area

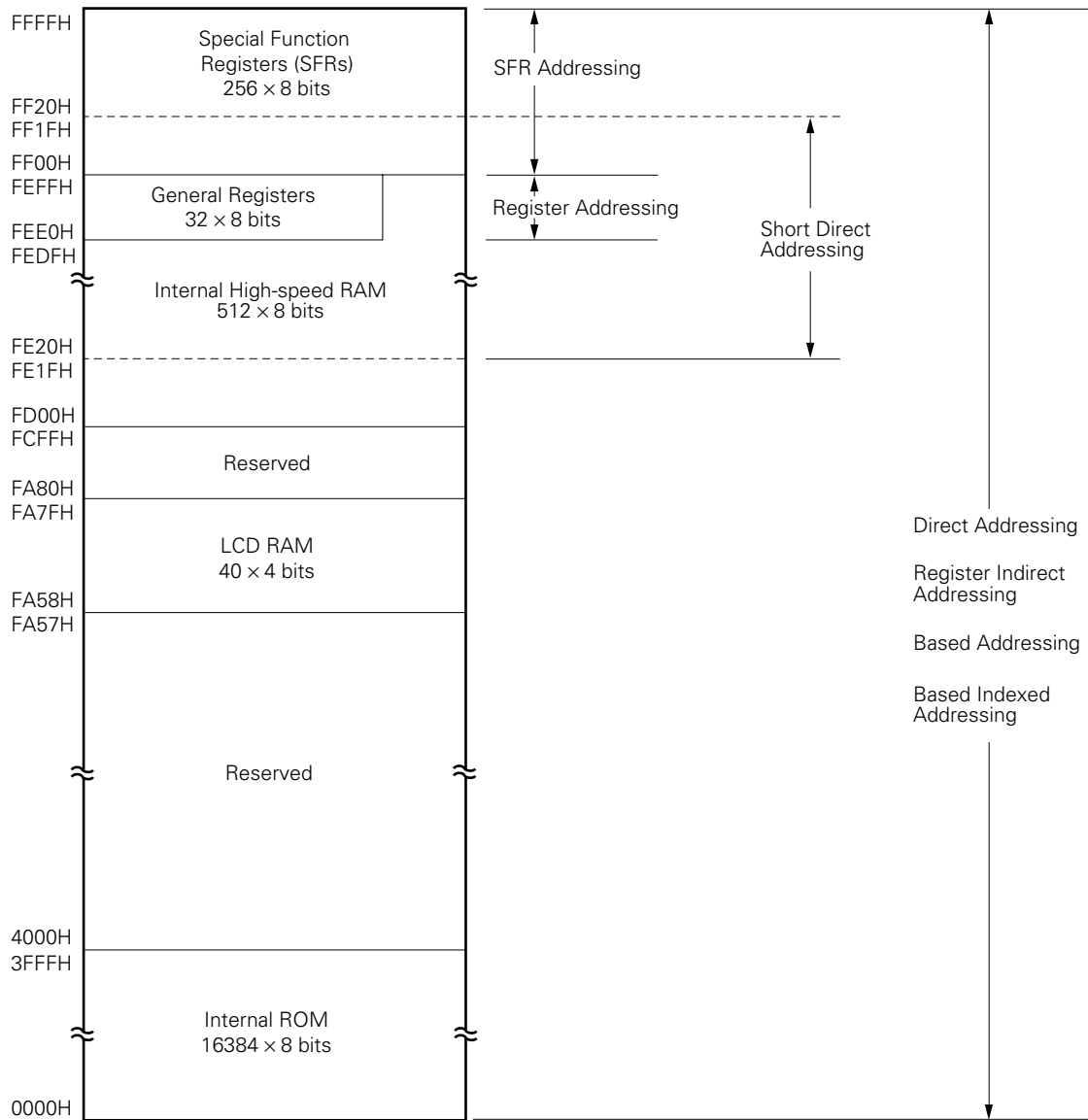
An on-chip peripheral hardware special-function register (SFR) is allocated in the area FF00H to FFFFH. (Refer to **Table 5-4**).

Caution Do not access addresses where the SFR is not assigned.

5.1.4 Data memory addressing

The μ PD78064, 78064Y subseries is provided with a variety of addressing modes which take account of memory manipulability, etc. Especially at addresses corresponding to data memory area, particular addressing modes are possible to meet the functions of the special function registers (SFRs) and general registers. This area is between FD00H and FFFFH for the μ PD78062 and 78062Y, and between FB00H and FFFFH for the other devices. Figures 5-5 to 5-8 show the data memory addressing modes.

Figure 5-5. Data Memory Addressing (μ PD78062, 78062Y)



www.DataSheet4U.com

Figure 5-6. Data Memory Addressing (μ PD78063, 78063Y)

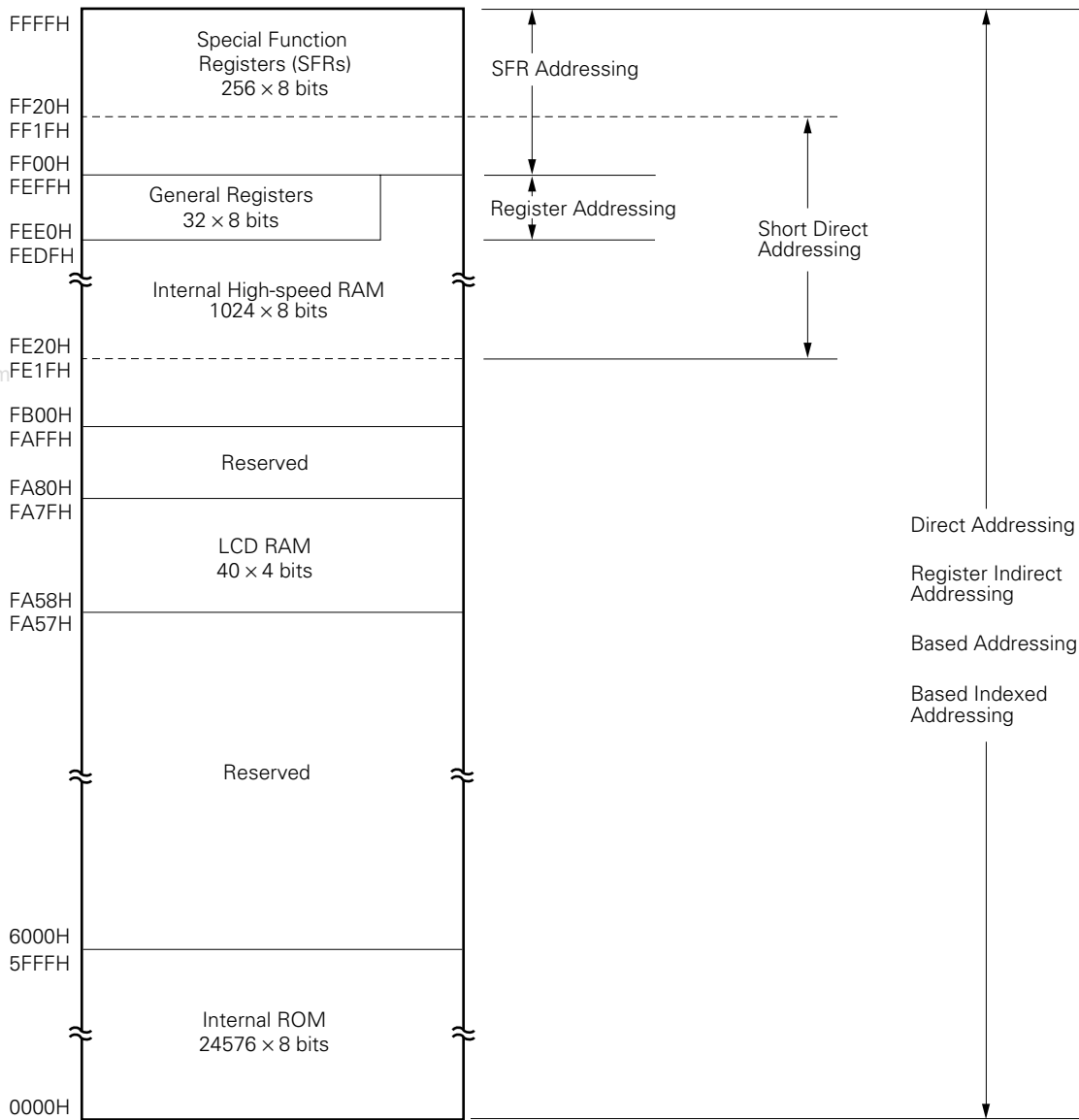
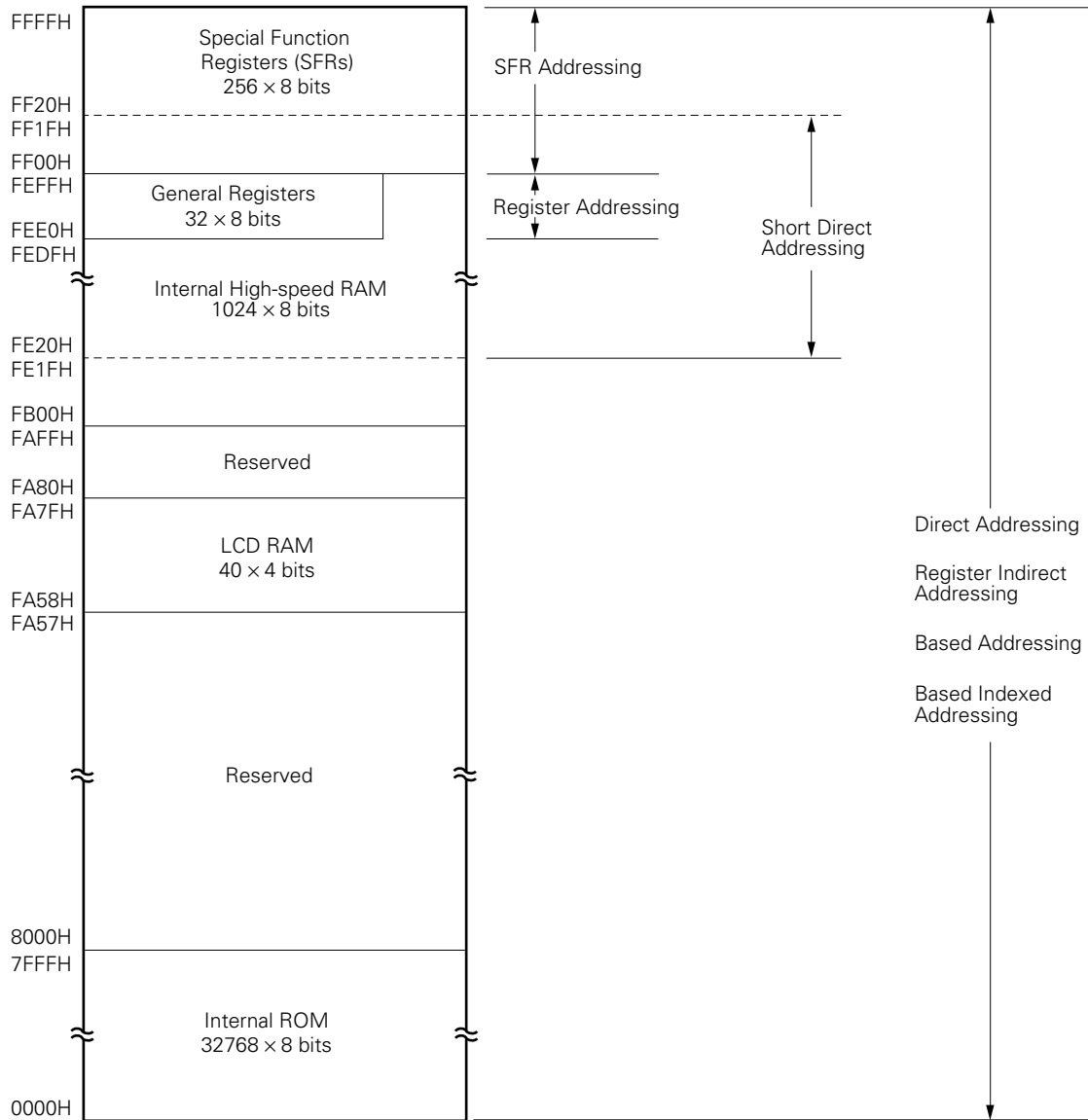
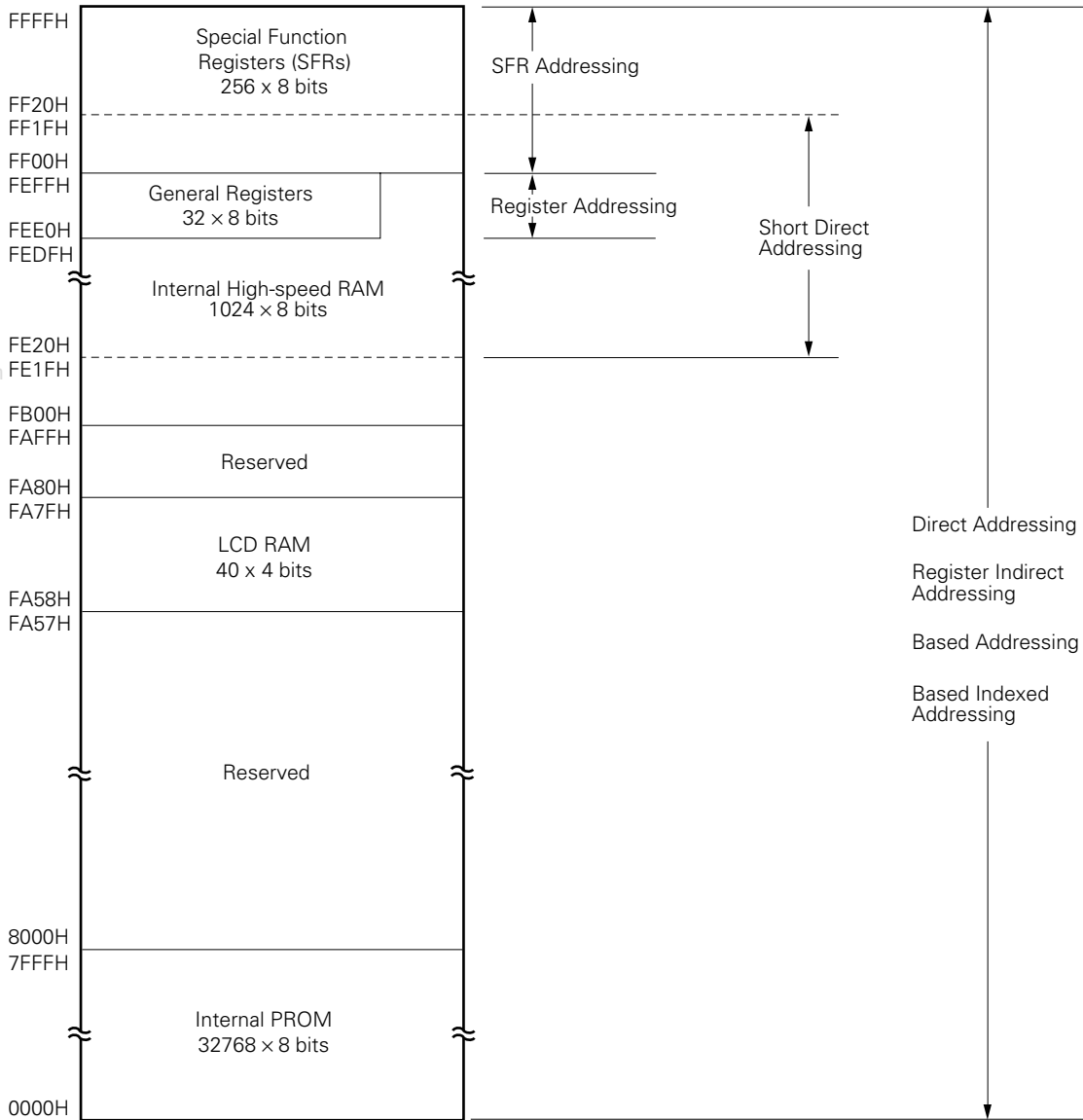


Figure 5-7. Data Memory Addressing (μ PD78064, 78064Y)



www.DataSheet4U.com

Figure 5-8. Data Memory Addressing (μ PD78P064, 78P064Y)



www.DataSheet4U.com

5.2 Processor Registers

The μ PD78064 and 78064Y subseries units incorporate the following processor registers.

5.2.1 Control registers

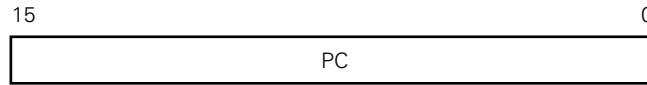
The control registers control the program sequence, statuses and stack memory. The control registers consist of a program counter, a program status word and a stack pointer.

(1) Program counter (PC)

The program counter is a 16-bit register which holds the address information of the next program to be executed.

In normal operation, the PC is automatically incremented according to the number of bytes of the instruction to be fetched. When a branch instruction is executed, immediate data and register contents are set. RESET input sets the reset vector table values at addresses 0000H and 0001H to the program counter.

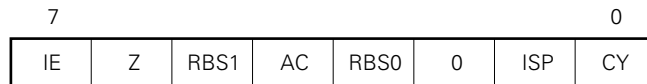
Figure 5-9. Program Counter Configuration



(2) Program status word (PSW)

The program status word is an 8-bit register consisting of various flags to be set/reset by instruction execution. Program status word contents are automatically stacked upon interrupt request generation or PUSH PSW instruction execution and are automatically reset upon execution of the RETB, RETI and POP PSW instructions. RESET input sets the PSW to 02H.

Figure 5-10. Program Status Word Configuration



(a) Interrupt enable flag (IE)

This flag controls the interrupt request acknowledge operations of the CPU.

When 0, the IE is set to DI, and only non-maskable interrupt request becomes acknowledgeable. Other interrupt requests are all disabled. When 1, the IE is set to EI and interrupt request acknowledge enable is controlled with an inservice priority flag (ISP), an interrupt mask flag for various interrupt sources and a priority specification flag.

The IE is reset to (0) upon DI instruction execution or interrupt acknowledgement and is set to (1) upon EI instruction execution.

(b) Zero flag (Z)

When the operation result is zero, this flag is set (1). It is reset (0) in all other cases.

(c) Register bank select flags (RBS0 and RBS1)

These are 2-bit flags to select one of the four register banks.

In these flags, the 2-bit information which indicates the register bank selected by SEL RBn instruction execution is stored.

(d) Auxiliary carry flag (AC)

If the operation result has a carry from bit 3 or a borrow at bit 3, this flag is set (1). It is reset (0) in all other cases.

(e) In-service priority flag (ISP)

This flag manages the priority of acknowledgeable maskable vectored interrupts. When this flag is 0, low-level vectored interrupts specified with a priority specify flag register (PR) are disabled for acknowledgement. When it is 1, all interrupts are acknowledgeable. Actual acknowledgement is controlled with the interrupt enable flag (IE).

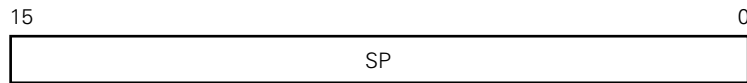
(f) Carry flag (CY)

This flag stores overflow and underflow upon add/subtract instruction execution. It stores the shift-out value upon rotate instruction execution and functions as a bit accumulator during bit manipulation instruction execution.

(3) Stack pointer (SP)

This is a 16-bit register to hold the start address of the memory stack area. Only the internal high-speed RAM area (FD00H-FEFFFH for the μ PD78062 and 78062Y, and FB00H-FEFFFH for the other devices) can be set as the stack area.

Figure 5-11. Stack Pointer Configuration



The SP is decremented ahead of write (save) to the stack memory and is incremented after read (reset) from the stack memory.

Each stack operation saves/resets data as shown in Figures 5-12 and 5-13.

Caution Since RESET input makes SP contents indeterminate, be sure to initialize the SP before instruction execution.

Figure 5-12. Data to be Saved to Stack Memory

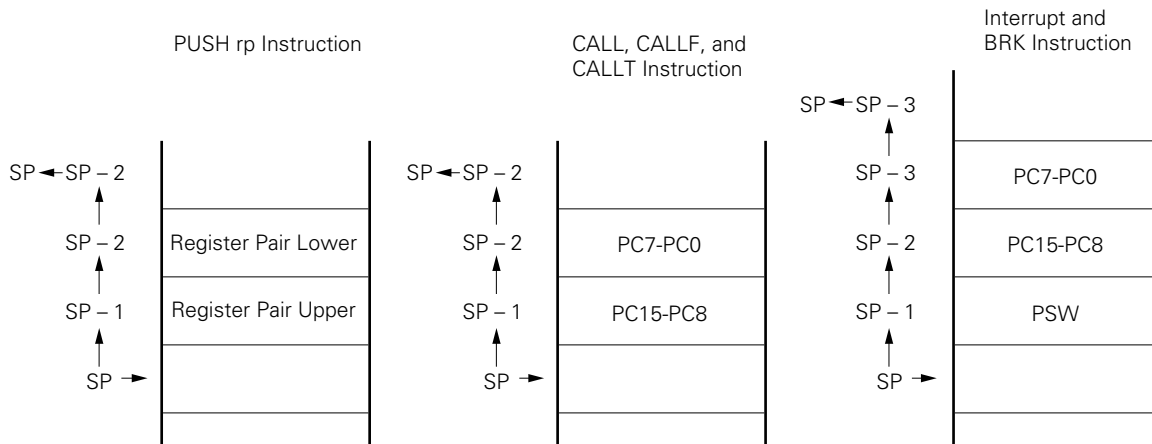
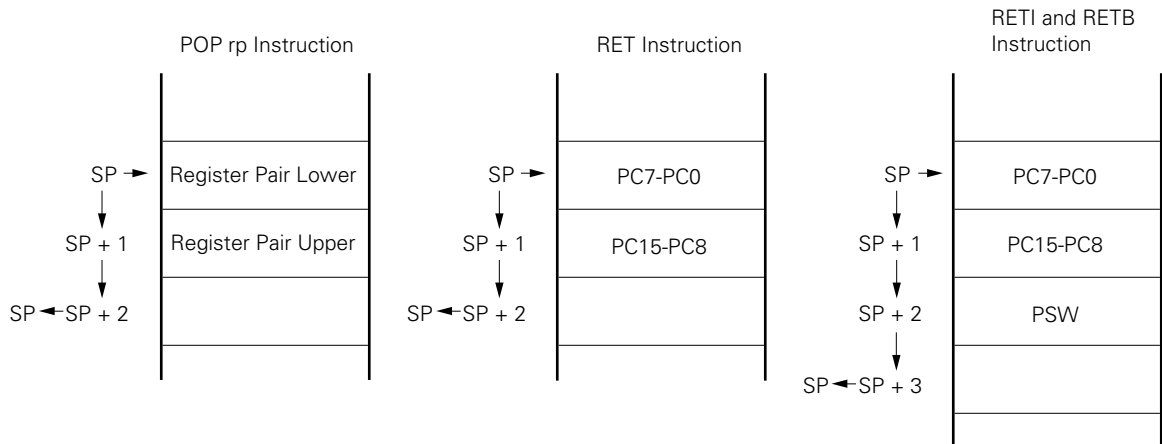


Figure 5-13. Data to be Reset from Stack Memory



5.2.2 General registers

A general register is mapped at particular addresses (FEE0H to FEFFH) of the data memory. It consists of 4 banks, each bank consisting of eight 8-bit registers (X, A, C, B, E, D, L and H).

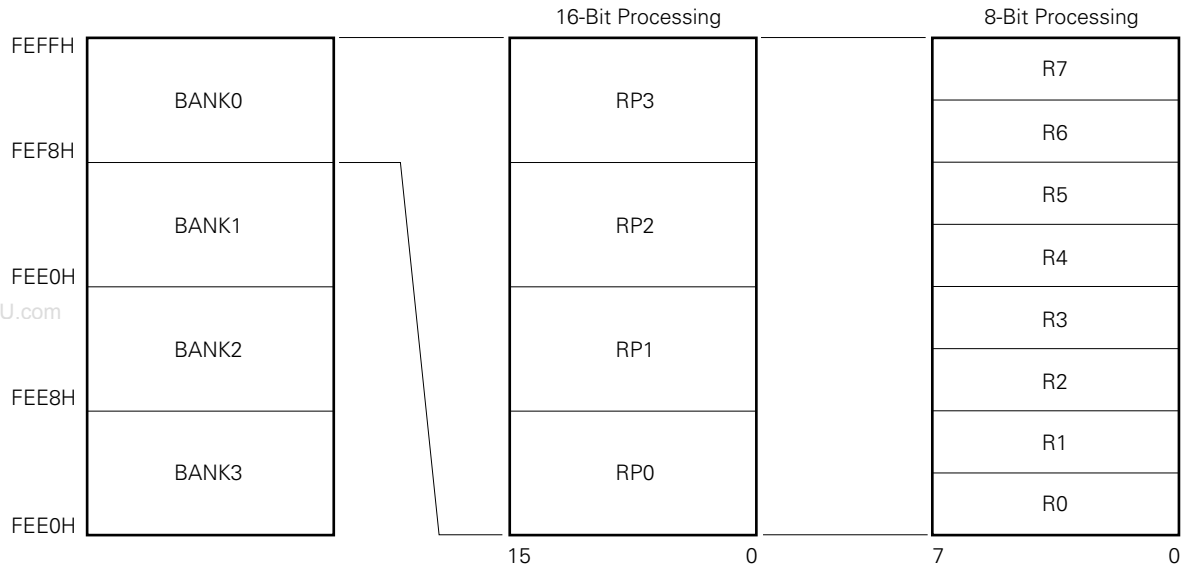
Each register can also be used as an 8-bit register. Two 8-bit registers can be used in pairs as a 16-bit register (AX, BC, DE and HL).

They can be described in terms of function names (X, A, C, B, E, D, L, H, AX, BC, DE and HL) and absolute names (R0 to R7 and RP0 to RP3).

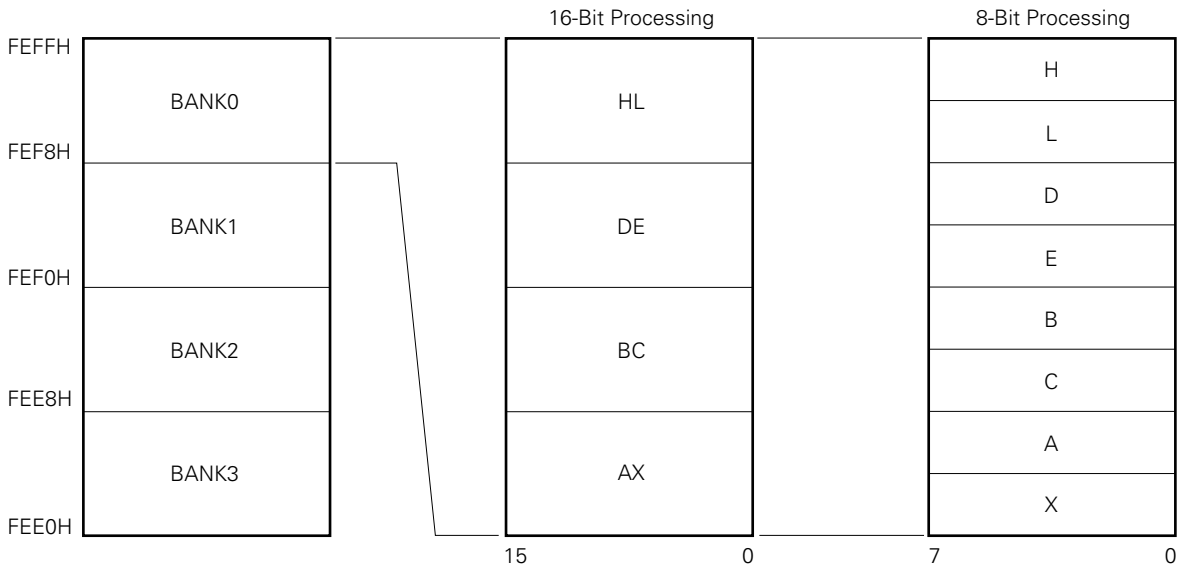
Register banks to be used for instruction execution are set with the CPU control instruction (SEL RBn). Because of the 4-register bank configuration, an efficient program can be created by switching between a register for normal processing and a register for interruption for each bank.

Figure 5-14. General Register Configuration

(a) Absolute Name



(b) Function Name



5.2.3 Special Function Register (SFR)

Unlike a general register, each special-function register has special functions.

It is allocated in the FF00H to FFFFH area.

The special-function register can be manipulated like the general register, with the operation, transfer and bit manipulation instructions. Manipulatable bit units, 1, 8 and 16, depend on the special-function register type.

Each manipulation bit unit can be specified as follows.

- 1-bit manipulation
Describe the symbol reserved with assembler for the 1-bit manipulation instruction operand (sfr.bit).
This manipulation can also be specified with an address.
- 8-bit manipulation
Describe the symbol reserved with assembler for the 8-bit manipulation instruction operand (sfr).
This manipulation can also be specified with an address.
- 16-bit manipulation
Describe the symbol reserved with assembler for the 16-bit manipulation instruction operand (sfrp).
When addressing an address, describe an even address.

Table 5-4 gives a list of special-function registers. The meaning of items in the table is as follows.

- Symbol
This is a symbol used in assembler (RA78K/0) to indicate an address of the built-in special-function register.
It is describable as an instruction operand.
- R/W
Indicates whether the corresponding special-function register can be read or written.
R/W : Read/write enable
R : Read only
W : Write only
- Manipulatable bit units
Manipulatable bit units, 1, 8, and 16, are indicated.
- After reset
Indicates each register status upon $\overline{\text{RESET}}$ input.

Table 5-4. Special-Function Register List (1/3)

Address	Special-Function Register (SFR) Name	Symbol	R/W	Manipulatable Bit Unit			After Reset	
				1 bit	8 bits	16 bits		
FF00H	Port0	P0	R/W	√	√	—	00H	
FF01H	Port1	P1		√	√	—		
FF02H	Port2	P2		√	√	—		
FF03H	Port3	P3		√	√	—		
FF07H	Port7	P7		√	√	—		
FF08H	Port8	P8		√	√	—		
FF09H	Port9	P9		√	√	—		
FF0AH	Port10	P10		√	√	—		
FF0BH	Port11	P11		√	√	—		
FF10H	Capture/compare register 00	CR00		—	—	√		Undefined
FF11H			—	—	√			
FF12H	Capture/compare register 01	CR01	—	—	√	Undefined		
FF13H			—	—	√			
FF14H	16-bit timer register	TM0	R	—	—	√	00H	
FF15H				—	—	√		
FF16H	Compare register 10	CR10	R/W	—	√	—	Undefined	
FF17H	Compare register 20	CR20		—	√	—		
FF18H	8-bit timer register 1	TMS	R	—	√	√	00H	
FF19H	8-bit timer register 2			TM1	—	√		√
FF1AH	Serial I/O shift register 0	SIO0	R/W	—	√	—	Undefined	
FF1FH	A/D conversion result register	ADCR	R	—	√	—		
FF20H	Port mode register 0	PM0	R/W	√	√	—	FFH	
FF21H	Port mode register 1	PM1		√	√	—		
FF22H	Port mode register 2	PM2		√	√	—		
FF23H	Port mode register 3	PM3		√	√	—		
FF27H	Port mode register 7	PM7		√	√	—		
FF28H	Port mode register 8	PM8		√	√	—		
FF29H	Port mode register 9	PM9		√	√	—		
FF2AH	Port mode register 10	PM10		√	√	—		
FF2BH	Port mode register 11	PM11		√	√	—		
FF40H	Timer clock select register 0	TCL0		√	√	—		00H
FF41H	Timer clock select register 1	TCL1		—	√	—		
FF42H	Timer clock select register 2	TCL2	—	√	—			
FF43H	Timer clock select register 3	TCL3	—	√	—	88H		
FF47H	Sampling clock select register	SCS	—	√	—	00H		
FF48H	16-bit timer mode control register	TMC0	√	√	—			

Table 5-4. Special-Function Register List (2/3)

Address	Special-Function Register (SFR) Name	Symbol		R/W	Manipulatable Bit Unit			After Reset	
					1 bit	8 bits	16 bits		
FF49H	8-bit timer mode control register	TMC1		R/W	√	√	—	00H	
FF4AH	Watch timer mode control register	TMC2			√	√	—		
FF4CH	Capture/compare control register 0	CRC0			√	√	—	04H	
FF4EH	16-bit timer output control register	TOC0			√	√	—	00H	
FF4FH	8-bit timer output control register	TOC1			√	√	—		
FF60H	Serial operating mode register 0	CSIM0			√	√	—		
FF61H	Serial bus interface control register	SBIC			√	√	—	R	
FF62H	Slave address register	SVA			—	√	—		Undefined
FF63H	Interrupt timing specify register	SINT			√	√	—		00H
FF70H	Asynchronous serial interface mode register	ASIM			√	√	—		
FF71H	Asynchronous serial interface status register	ASIS			√	√	—		
FF72H	Serial operating mode register 2	CSIM2			RW	√	√		—
FF73H	Baud rate generator control register	BRGC			—	√	—		FFH
FF74H	Transmit shift register	TXS	SIO2	W	—	√	—		
	Receive buffer register	RXB		R					
FF80H	A/D converter mode register	ADM		R/W	√	√	—		01H
FF84H	A/D converter input select register	ADIS			—	√	—		00H
FFB0H	LCD display mode register	LCDM			√	√	—		
FFB2H	LCD display control register	LCDC			√	√	—		02H
FFB8H	Key return mode register	KRM			√	√	—		
FFE0H	Interrupt request flag register 0L	IF0	IF0L		√	√	√	00H	
FFE1H	Interrupt request flag register 0H		IF0H		√	√			
FFE2H	Interrupt request flag register 1L		IF1L		√	√	—	FFH	
FFE4H	Interrupt mask flag register 0L	MK0	MK0L		√	√	√		
FFE5H	Interrupt mask flag register 0H		MK0H		√	√			
FFE6H	Interrupt mask flag register 1L		MK1L		√	√	—		
FFE8H	Priority order specify flag register 0L	PR0	PR0L		√	√	√		
FFE9H	Priority order specify flag register 0H		PR0H		√	√			
FFEAH	Priority order specify flag register 1L		PR1L	√	√	—	00H		
FFECH	External interrupt mode register 0		INTM0	—	√	—			
FFEDH	External interrupt mode register 1		INTM1	—	√	—			
FFF0H	Memory size switching register		IMS	—	√	—		(Note)	
FFF2H	Oscillation mode selection register	OSMS		W	—	√	—	00H	
FFF3H	Pull-up resistor option register H	PUOH		R/W	√	√	—		

Table 5-4. Special-Function Register List (3/3)

Address	Special-Function Register (SFR) Name	Symbol	R/W	Manipulatable Bit Unit			After Reset
				1 bit	8 bits	16 bits	
FFF7H	Pull-up resistor option register L	PUOL	R/W	√	√	—	00H
FFF9H	Watchdog timer mode register	WDTM		√	√	—	
FFFAH	Oscillation stabilization time select register	OSTS		—	√	—	04H
FFFBH	Processor clock control register	PCC		√	√	—	

Note The value after reset depends on products.

μ PD78062, 78062Y: 44H, μ PD78063, 78063Y: C6H, μ PD78064, 78064Y: C8H, μ PD78P064, 78P064Y:

C8H.

5.3 Instruction Address Addressing

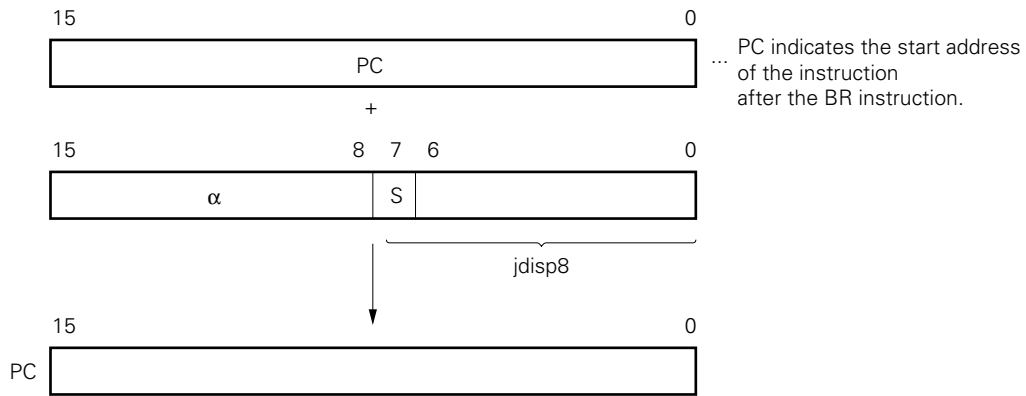
An instruction address is determined by program counter (PC) contents and is normally incremented (+1 for each byte) automatically according to the number of bytes of an instruction to be fetched each time another instruction is executed. When a branch instruction is executed, the branch destination information is set to the PC and branched by the following addressing. (For details of instructions, refer to **78K/0 USER'S MANUAL: Instruction (IEU-1372)**.)

5.3.1 Relative Addressing

[Function]

The value obtained by adding 8-bit immediate data (displacement value: *jdisp8*) of an instruction code to the start address of the following instruction is transferred to the program counter (PC) and branched. The displacement value is treated as signed two's complement data (−128 to +127) and bit 7 becomes a sign bit. This function is carried out when the BR \$addr16 instruction or a conditional branch instruction is executed.

[Illustration]



When S = 0, all bits of α are 0.
 When S = 1, all bits of α are 1.

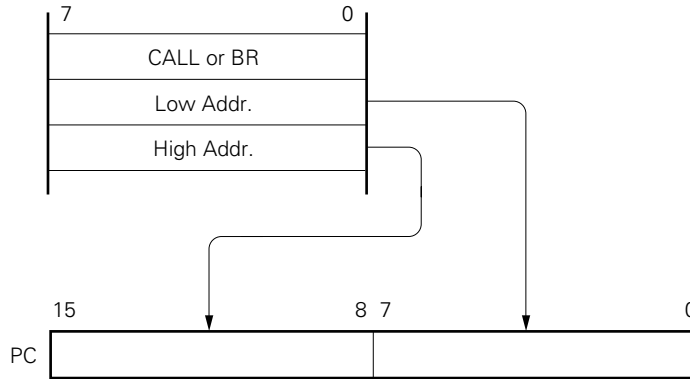
5.3.2 Immediate addressing

[Function]

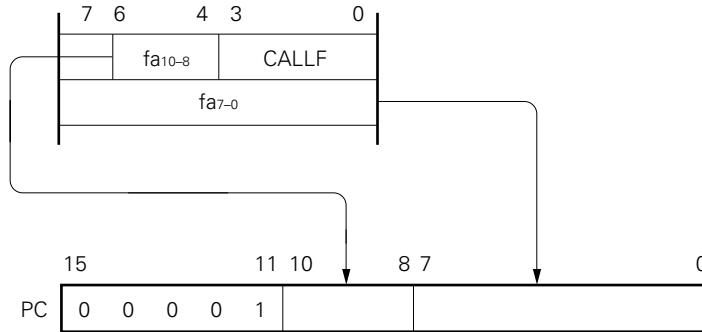
Immediate data in the instruction word is transferred to the program counter (PC) and branched. This function is carried out when the CALL !addr16 or BR !addr16 or CALLF !addr11 instruction is executed.

[Illustration]

In the case of CALL !addr16 and BR !addr16 instructions



In the case of CALLF !addr11 instruction



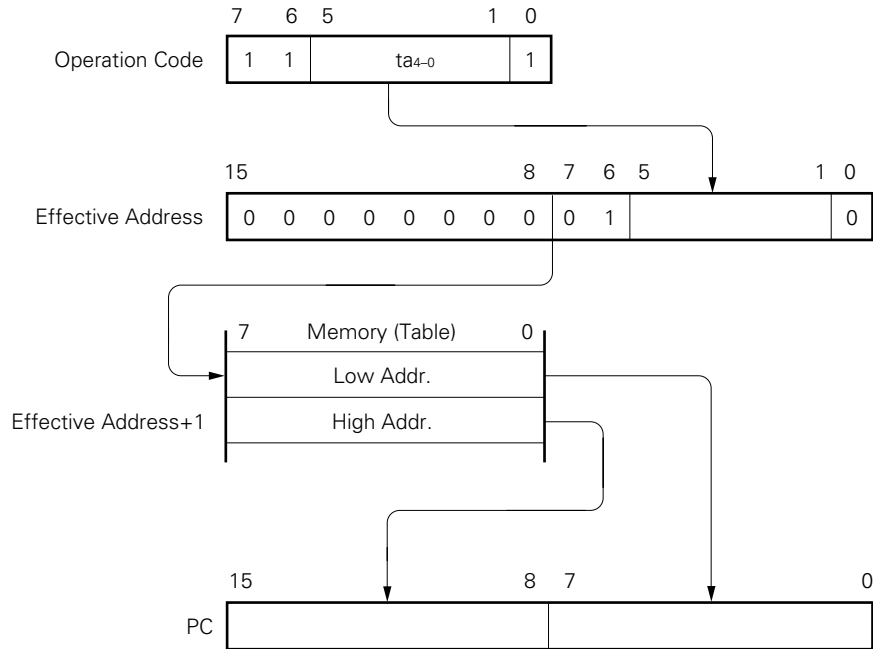
5.3.3 Table indirect addressing

[Function]

Table contents (branch destination address) of the particular location to be addressed by bits 1 to 5 of the immediate data of an operation code are transferred to the program counter (PC) and branched.

This function is carried out when the CALLT [addr5] instruction is executed.

[Illustration]



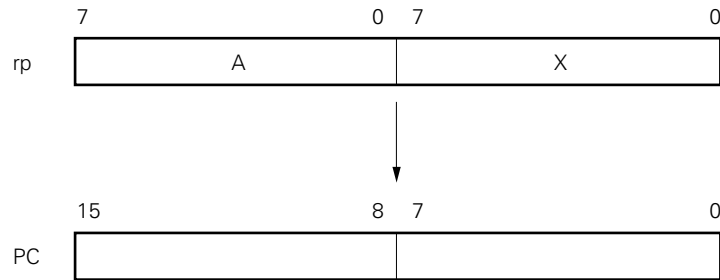
www.DataSheet4U.com

5.3.4 Register addressing

[Function]

Register pair (AX) contents to be specified with an instruction word are transferred to the program counter (PC) and branched.

This function is carried out when the BR AX instruction is executed.

[Illustration]

5.4 Operand Address Addressing

The following various methods are available to specify the register and memory (addressing) which undergo manipulation during instruction execution.

5.4.1 Implied addressing

[Function]

The register which functions as an accumulator (A and AX) in the general register is automatically addressed. Of the μ PD78064 and 78064Y subseries instruction words, the following instructions employ implied addressing.

Instruction	Register to be Specified by Implied Addressing
MULU	A register for multiplicand and AX register for product storage
DIVUW	AX register for dividend and quotient storage
ADJBA/ADJBS	A register for storage of numeric values which become decimal correction targets
ROR4/ROL4	A register for storage of digit data which undergoes digit rotation

[Operand format]

Because implied addressing can be automatically employed with an instruction, no particular operand format is necessary.

[Description example]

In the case of MULU X

With an 8-bit \times 8-bit multiply instruction, the product of A register and X register is stored in AX. In this example, the A and AX registers are specified by implied addressing.

5.4.2 Register addressing

[Function]

The general register to be specified is accessed as an operand with the register specify code (Rn and RPN) of an instruction word in the registered bank specified with the register bank select flag (RBS0 to RBS1).

Register addressing is carried out when an instruction with the following operand format is executed. When an 8-bit register is specified, one of the eight registers is specified with 3 bits in the operation code.

[Operand format]

Identifier	Description
r	X, A, C, B, E, D, L, H
rp	AX, BC, DE, HL

'r' and 'rp' can be described with function names (X, A, C, B, E, D, L, H, AX, BC, DE and HL) as well as absolute names (R0 to R7 and RP0 to RP3).

[Description example]

MOV A, C; when selecting C register as r

Operation code

0	1	1	0	0	0	1	0
---	---	---	---	---	---	---	---

INCW DE; when selecting DE register pair as rp

Operation code

1	0	0	0	0	1	0	0
---	---	---	---	---	---	---	---

5.4.3 Direct addressing

[Function]

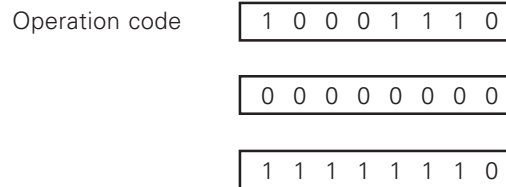
The memory to be manipulated is addressed with immediate data in an instruction word becoming an operand address.

[Operand format]

Identifier	Description
addr16	Label or 16-bit immediate data

[Description example]

MOV A, !FE00H; when setting !addr16 to FE00H



www.DataSheet4U.com

5.4.4 Short direct addressing

[Function]

The memory to be manipulated in the fixed space is directly addressed with 8-bit data in an instruction word. This addressing is applied to the 256-byte space FE20H to FF1FH. An internal RAM and a special-function register (SFR) are mapped at FE20H to FEFFH and FF00H to FF1FH, respectively.

If the SFR area (FF00H to FF1FH) where short direct addressing is applied, ports which are frequently accessed in a program and a compare register of the timer/event counter and a capture register of the timer/event counter are mapped and these SFRs can be manipulated with a small number of bytes and clocks.

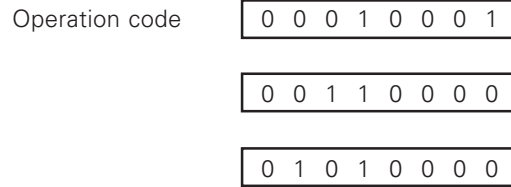
When 8-bit immediate data is at 20H to FFH, bit 8 of an effective address is set to 0. When it is at 00H to 1FH, bit 8 is set to 1.

www.DataSheet4U.com [Operand format]

Identifier	Description
saddr	Label of FE20H to FF1FH immediate data
saddrp	Label of FE20H to FF1FH immediate data (even address only)

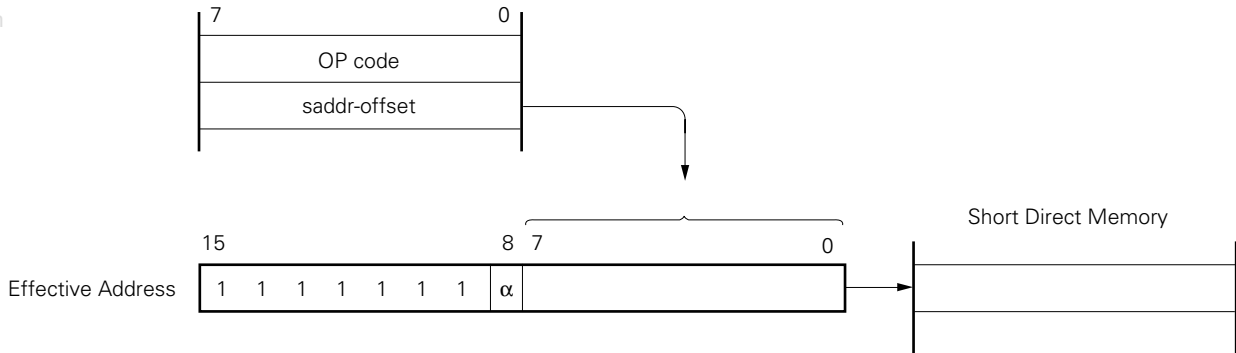
[Description example]

MOV FE30H, #50H; when setting saddr to FE30H and immediate data to 50H



[Illustration]

www.DataSheet4U.com



When 8-bit immediate data is 20H to FFH, $\alpha = 0$

When 8-bit immediate data is 00H to 1FH, $\alpha = 1$

5.4.5 Special-Function Register (SFR) addressing

[Function]

The memory-mapped special-function register (SFR) is addressed with 8-bit immediate data in an instruction word.

This addressing is applied to the 240-byte spaces FF00H to FFCFH and FFE0H to FFFFH. However, the SFR mapped at FF00H to FF1FH can be accessed with short direct addressing.

[Operand format]

Identifier	Description
sfr	Special-function register name
sfrp	16-bit manipulatable special-function register name (even address only)

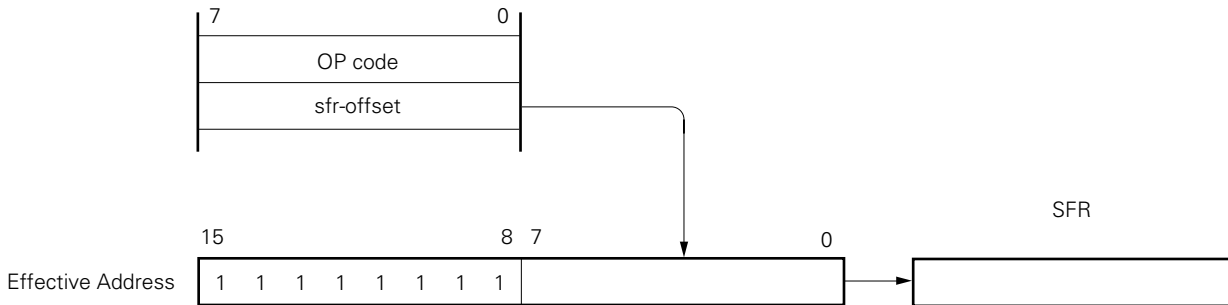
www.DataSheet4U.com

[Description example]

MOV PM0, A; when selecting PM0 as sfr



[Illustration]



5.4.6 Register indirect addressing

[Function]

Register pair contents specified with a register pair specify code in an instruction word of the register bank specified with a register bank select flag (RBS0 and RBS1) serve as an operand address for addressing the memory to be manipulated. This addressing can be carried out for all the memory spaces.

[Operand format]

Identifier	Description
—	[DE], [HL]

www.DataSheet4U.com

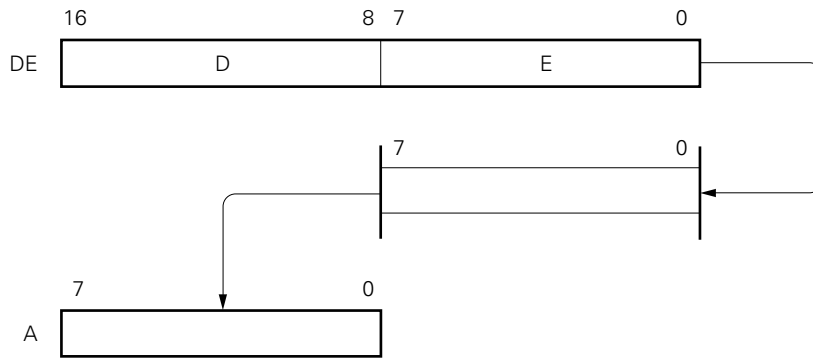
[Description example]

MOV A, [DE]; when selecting [DE] as register pair

Operation code

1	0	0	0	0	1	0	1
---	---	---	---	---	---	---	---

[Illustration]



5.4.7 Based addressing

[Function]

8-bit immediate data is added as offset data to the contents of the base register, that is, the HL register pair in an instruction word of the register bank specified with the register bank select flag (RBS0 and RBS1) and the sum is used to address the memory. Addition is performed by expanding the offset data as a positive number to 16 bits. A carry from the 16th bit is ignored. This addressing can be carried out for all the memory spaces.

[Operand format]

Identifier	Description
—	[HL + byte]

www.DataSheet4U.co

[Description example]

MOV A, [HL + 10H]; when setting byte to 10H

Operation code	1 0 1 0 1 1 1 0
	0 0 0 1 0 0 0 0

5.4.8 Based indexed addressing

[Function]

The B or C register contents specified in an instruction are added to the contents of the base register, that is, the HL register pair in an instruction word of the register bank specified with the register bank select flag (RBS0 and RBS1) and the sum is used to address the memory.

Addition is performed by expanding the offset data as a positive number to 16 bits. A carry from the 16th bit is ignored. This addressing can be carried out for all the memory spaces.

[Operand format]

Identifier	Description
—	[HL + B], [HL + C]

www.DataSheet4U.com

[Description example]

In the case of MOV A, [HL + B]

Operation code 1 0 1 0 1 0 1 1

5.4.9 Stack addressing

[Function]

The stack area is indirectly addressed with the stack pointer (SP) contents.

This addressing method is automatically employed when the PUSH, POP, subroutine call and RETURN instructions are executed or the register is saved/reset upon generation of an interrupt request.

Stack addressing enables to address the internal high-speed RAM area only.

[Description example]

In the case of PUSH DE

Operation code 1 0 1 1 0 1 0 1

MEMO

www.DataSheet4U.com

CHAPTER 6 PORT FUNCTIONS

6.1 Port Functions

The μ PD78064 and 78064Y subseries units incorporate two input ports and 55 input/output ports. Figure 6-1 shows the port configuration. Every port is capable of 1-bit and 8-bit manipulations and can carry out considerably varied control operations. Besides port functions, the ports can also serve as on-chip hardware input/output pins.

Figure 6-1. Port Types

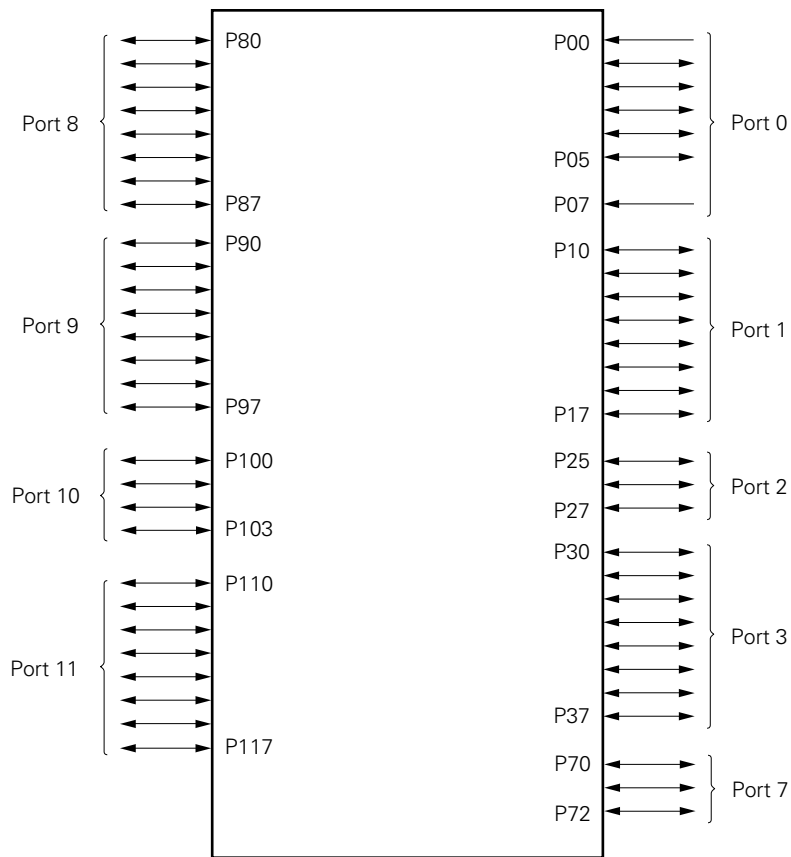


Table 6-1. Port Functions (μ PD78064 subseries)

Pin Name	Function		Dual-Function Pin	
P00	Port 0. 7-bit input/output port.	Input only	INTP0/TI00	
P01		Input/output mode can be specified bit-wise.	INTP1/TI01	
P02		If used as an input port, a pull-up resistor can be connected by software.		INTP2
P03				INTP3
P04				INTP4
P05				INTP5
P07		Input only		XT1
P10 to P17	Port 1. 8-bit input/output port. Input/output mode can be specified bit-wise. If used as an input port, a pull-up resistor can be connected by software.		ANI0 to ANI7	
P25	Port 2.		SI0/SB0	
P26	3-bit input/output port. Input/output mode can be specified bit-wise.		SO0/SB1	
P27	If used as an input port, a pull-up resistor can be connected by software.		$\overline{\text{SCK0}}$	
P30	Port 3.		TO0	
P31	8-bit input/output port. Input/output mode can be specified bit-wise.		TO1	
P32	If used as an input port, a pull-up resistor can be connected by software.		TO2	
P33			TI1	
P34			TI2	
P35			PCL	
P36			BUZ	
P37			—	
P70	Port 7.		SI2/RxD	
P71	3-bit input/output port. Input/output mode can be specified bit-wise.		SO2/TxD	
P72	If used as an input port, a pull-up resistor can be connected by software.		$\overline{\text{SCK2/ASCK}}$	
P80 to P87	Port 8. 8-bit input/output port. Input/output mode can be specified bit-wise. If used as an input port, a pull-up resistor can be connected by software. This port can be used as a segment signal output port or an I/O port in 2-bit units by setting LCD control register.		S39-S32	
P90 to P97	Port 9. 8-bit input/output port. Input/output mode can be specified bit-wise. If used as an input port, a pull-up resistor can be connected by software. This port can be used as a segment signal output port or an I/O port in 2-bit units by setting LCD control register.		S31-S24	
P100 to P103	Port 10. 4-bit input/output port. Input/output mode can be specified bit-wise. If used as an input port, a pull-up resistor can be connected by software. This port can directly drive LEDs.		—	
P110 to P117	Port 11. 8-bit input/output port. Input/output mode can be specified bit-wise. If used as an input port, a pull-up resistor can be connected by software. Falling edge detection is possible.		—	

Table 6-2. Port Functions (μ PD78064Y subseries)

Pin Name	Function	Dual-Function Pin
P00	Port 0. Input only	INTP0/TI00
P01	7-bit input/output port. If used as an input port, a pull-up resistor can be connected by software.	Input/output mode can be specified bit-wise. INTP1/TI01
P02		INTP2
P03		INTP3
P04		INTP4
P05		INTP5
P07		Input only XT1
P10 to P17	Port 1. 8-bit input/output port. Input/output mode can be specified bit-wise. If used as an input port, a pull-up resistor can be connected by software.	ANI0 to ANI7
P25	Port 2. 3-bit input/output port. Input/output mode can be specified bit-wise. If used as an input port, a pull-up resistor can be connected by software.	SI0/SB0
P26		SO0/SB1
P27		SCK0
P30	Port 3. 8-bit input/output port. Input/output mode can be specified bit-wise. If used as an input port, a pull-up resistor can be connected by software.	TO0
P31		TO1
P32		TO2
P33		TI1
P34		TI2
P35		PCL
P36		BUZ
P37		—
P70		Port 7.
P71	3-bit input/output port. Input/output mode can be specified bit-wise. If used as an input port, a pull-up resistor can be connected by software.	SO2/TxD
P72		SCK2/ASCK
P80 to P87	Port 8. 8-bit input/output port. Input/output mode can be specified bit-wise. If used as an input port, a pull-up resistor can be connected by software. This port can be used as a segment signal output port or an I/O port in 2-bit units by setting LCD control register.	S39-S32
P90 to P97	Port 9. 8-bit input/output port. Input/output mode can be specified bit-wise. If used as an input port, a pull-up resistor can be connected by software. This port can be used as a segment signal output port or an I/O port in 2-bit units by setting LCD control register.	S31-S24
P100 to P103	Port 10. 4-bit input/output port. Input/output mode can be specified bit-wise. If used as an input port, a pull-up resistor can be connected by software. This port can directly drive LEDs.	—
P110 to P117	Port 11. 8-bit input/output port. Input/output mode can be specified bit-wise. If used as an input port, a pull-up resistor can be connected by software. Falling edge detection is possible.	—

www.DataSheet4U.com

6.2 Port Configuration

A port consists of the following hardware:

Table 6-3. Port Configuration

Item	Configuration
Control register	Port mode register (PMm: m = 0 to 3, 7 to 11) Pull-up resistor option register (PUOH, PUOL) Key return mode register (KRM)
Port	Total: 57 ports (2 inputs, 55 inputs/outputs)
Pull-up resistor	Total: 55 (software specifiable: 55)

www.DataSheet4U.com

6.2.1 Port 0

Port 0 is an 7-bit input/output port with output latch. P01 to P05 pins can specify the input mode/output mode in 1-bit units with the port mode register 0. P00 and P07 pins are input-only ports. When P01 to P05 pins are used as input ports, a pull-up resistor can be connected to them in 5-bit units with a pull-up resistor option register L.

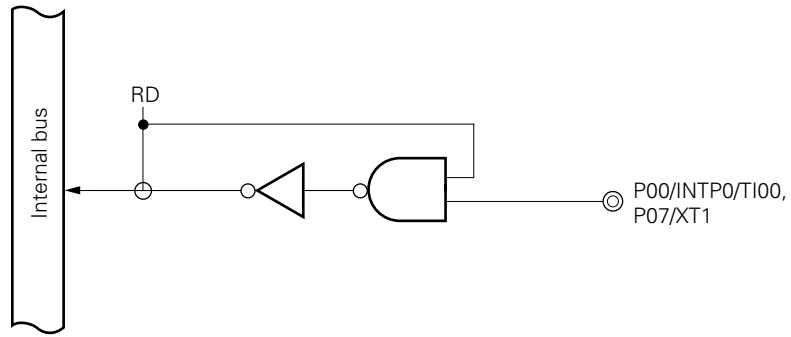
Dual-functions include external interrupt input, external count clock input to the timer and crystal connection for subsystem clock oscillation.

$\overline{\text{RESET}}$ input sets port 0 to input mode.

Figures 6-2 and 6-3 show block diagrams of port0.

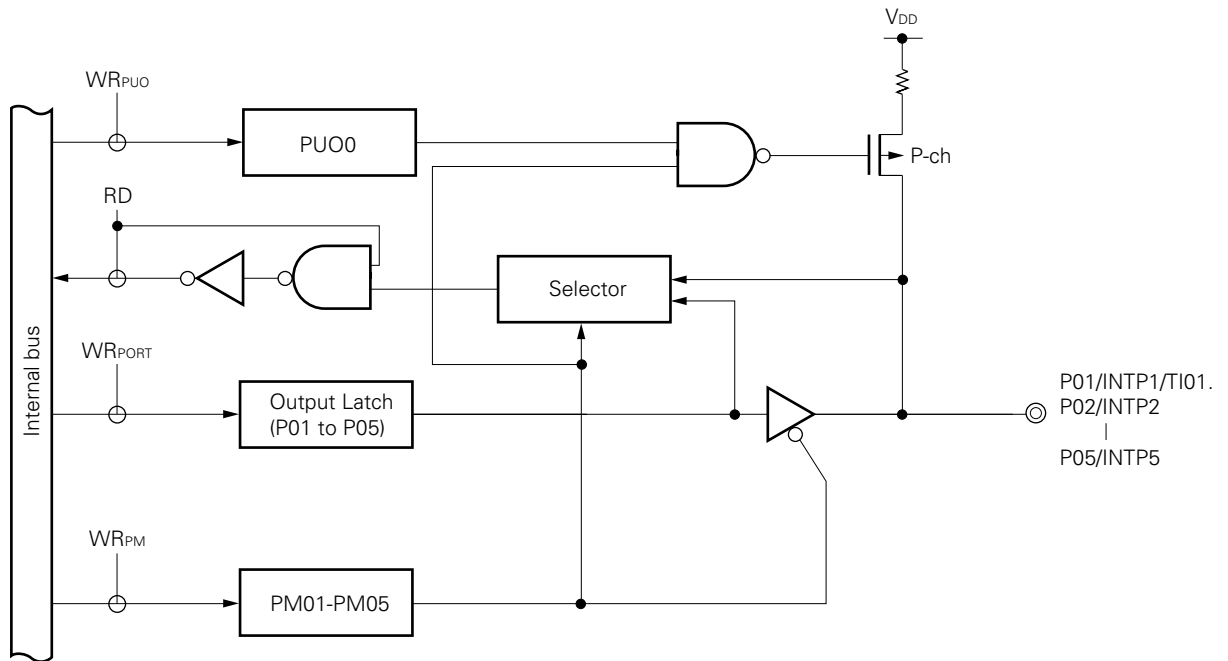
Caution Because port 0 also serves for external interrupt input, when the port function output mode is specified and the output level is changed, the interrupt request flag is set. Thus, when the output mode is used, set the interrupt mask flag to 1.

Figure 6-2. P00 and P07 Configurations



www.DataSheet4U.com

Figure 6-3. P01 to P05 Configurations



- PUO : Pull-up resistor option register
- PM : Port mode register
- RD : Port 0 read signal
- WR : Port 0 write signal

6.2.2 Port 1

Port 1 is an 8-bit input/output port with output latch. It can specify the input mode/output mode in 1-bit units with a port mode register 1. When P10 to P17 pins are used as input ports, a pull-up resistor can be connected to them in 8-bit units with a pull-up resistor option register L.

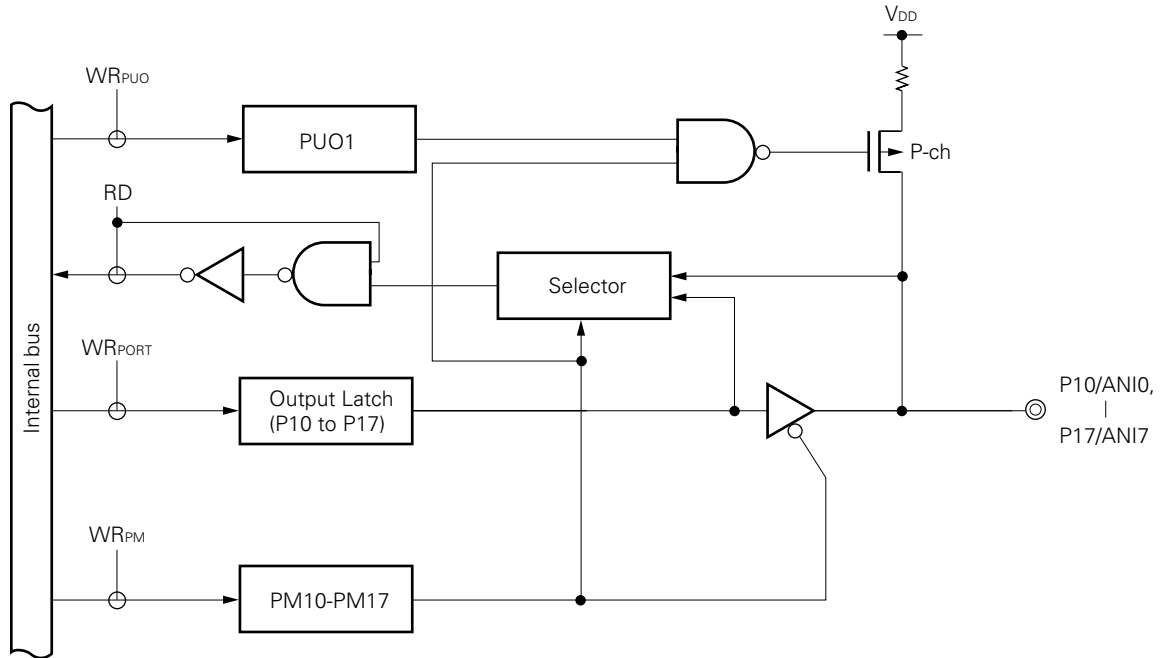
Dual-functions include an A/D converter analog input.

$\overline{\text{RESET}}$ input sets port 1 to input mode.

Figure 6-4 shows a block diagram of port 1.

Caution A pull-up resistor cannot be used for pins used as A/D converter analog input.

Figure 6-4. P10 to P17 Configurations



- PUO : Pull-up resistor option register
- PM : Port mode register
- RD : Port 1 read signal
- WR : Port 1 write signal

6.2.3 Port 2 (μ PD78064 Subseries)

Port 2 is an 3-bit input/output port with output latch. P25 to P27 pins can specify the input mode/output mode in 1-bit units with the port mode register 2. When P25 to P27 pins are used as input ports, a pull-up resistor can be connected to them in 3-bit units with a pull-up resistor option register L.

Dual-functions include serial interface data input/output and clock input/output.

$\overline{\text{RESET}}$ input sets port 2 to input mode.

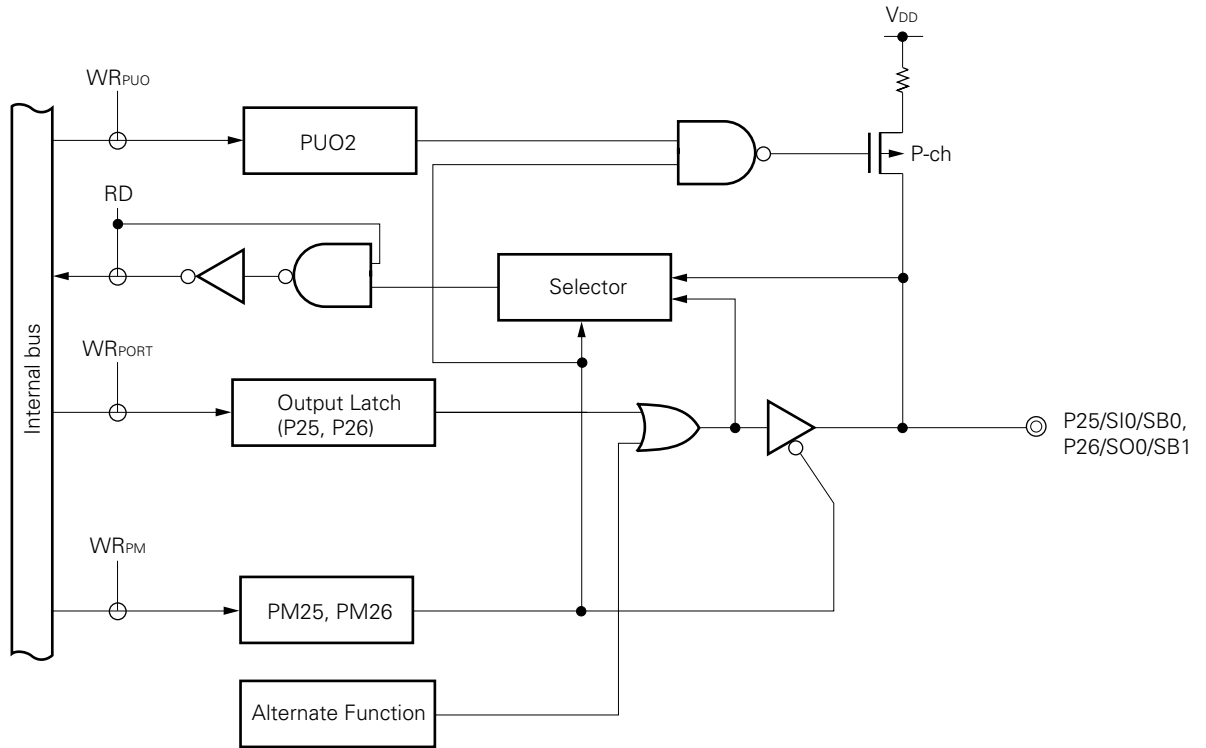
Figures 6-5 and 6-6 show a block diagram of port 2.

Cautions 1. When used as a serial interface, set the input/output and output latch according to its functions. For the setting method, refer to Figure 15-4 Serial Operating Mode Register 0 Format.

2. When reading the pin state in SBI mode, set PM2n to 1 (n = 5, 6) (Refer to the description of (10) SBI mode precautions (e) in section 15.4.3 "SBI Mode Operation").

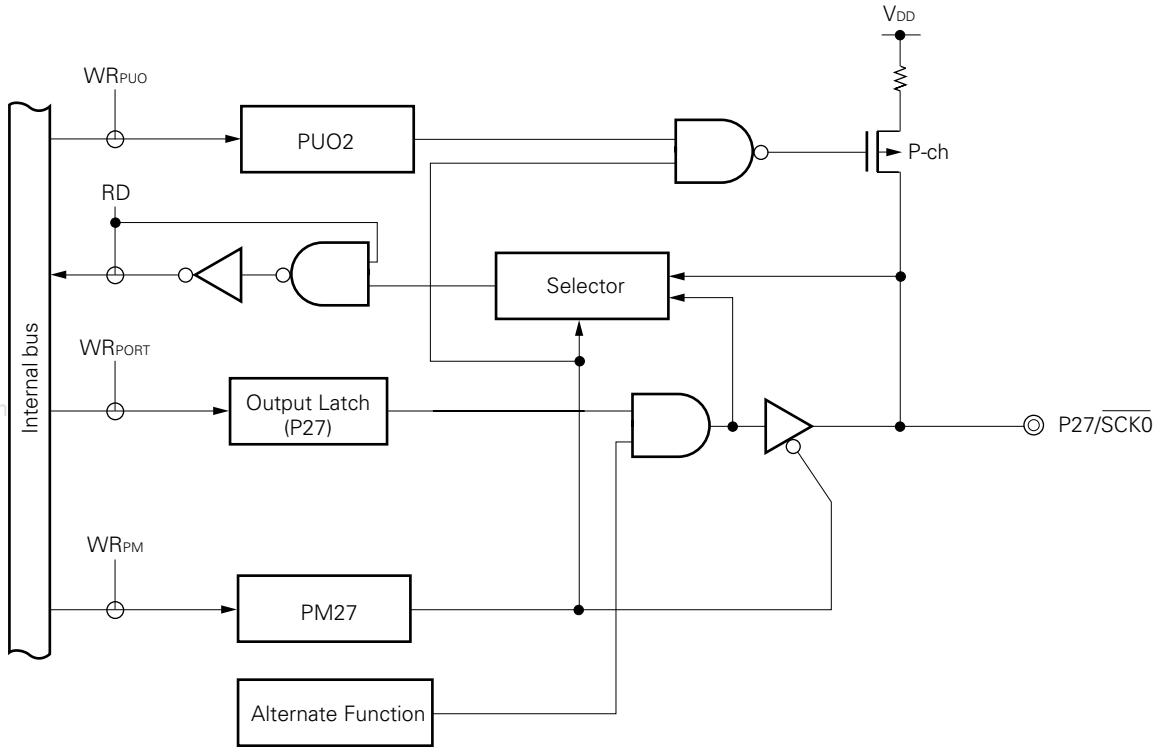
www.DataSheet4U.com

Figure 6-5. P25, P26 Configurations (μ PD78064 subseries)



- PUO : Pull-up resistor option register
- PM : Port mode register
- RD : Port 2 read signal
- WR : Port 2 write signal

Figure 6-6. P27 Configuration (μ PD78064 subseries)



- PUO : Pull-up resistor option register
- PM : Port mode register
- RD : Port 2 read signal
- WR : Port 2 write signal

6.2.4 Port 2 (μ PD78064Y Subseries)

Port 2 is an 3-bit input/output port with output latch. P25 to P27 pins can specify the input mode/output mode in 1-bit units with the port mode register 2. When P25 to P27 pins are used as input ports, a pull-up resistor can be connected to them in 3-bit units with a pull-up resistor option register L.

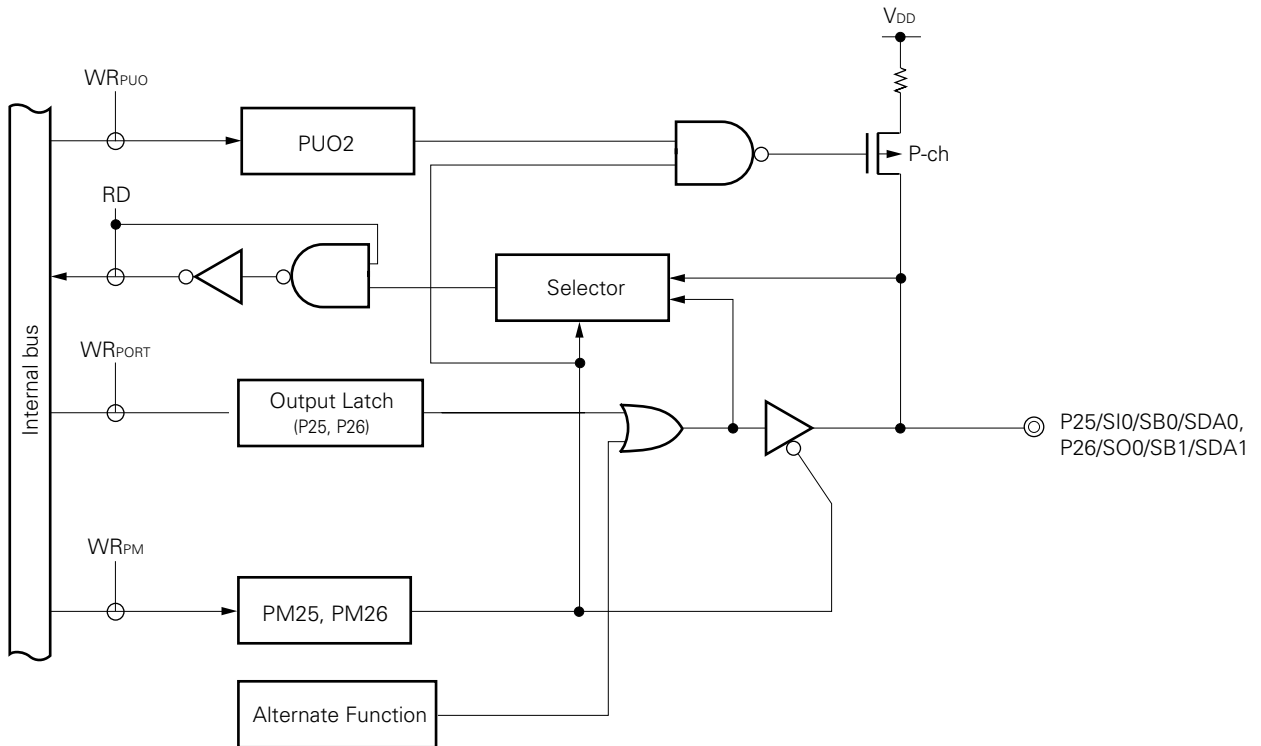
Dual-functions include serial interface data input/output and clock input/output.

$\overline{\text{RESET}}$ input sets port 2 to input mode.

Figures 6-7 and 6-8 show a block diagram of port 2.

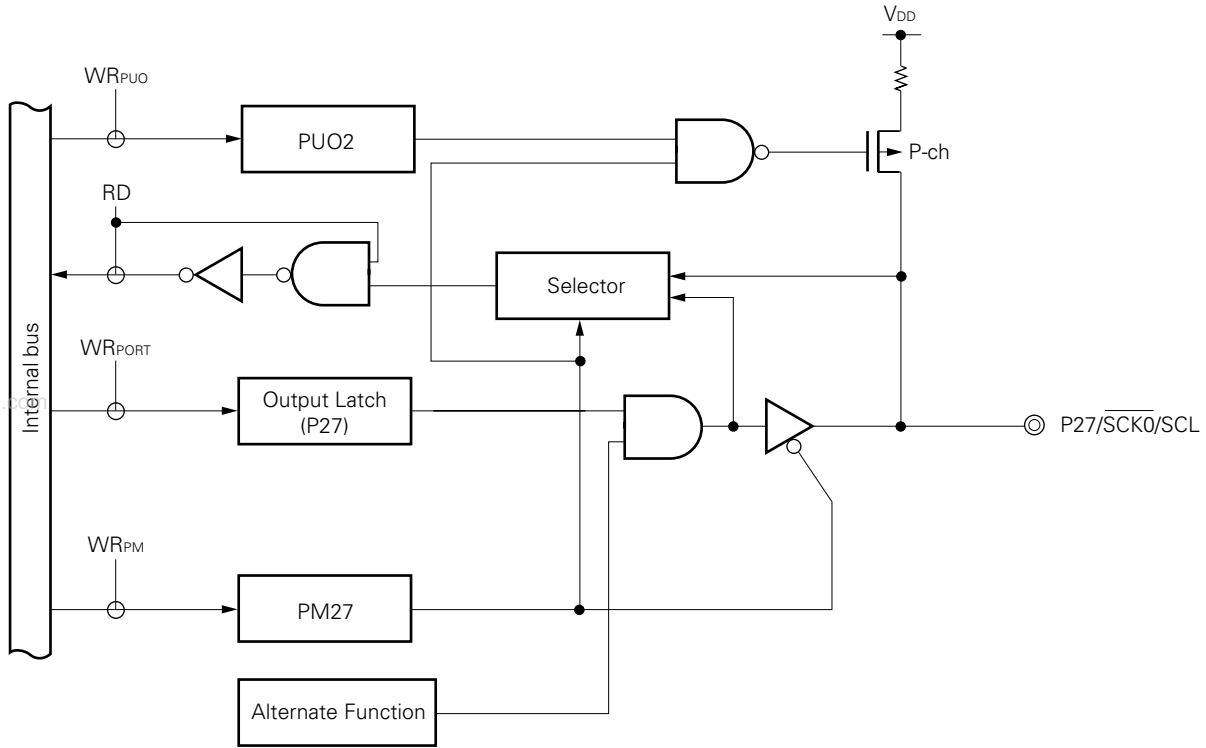
Caution When used as a serial interface, set the input/output and output latch according to its functions. For the setting method, refer to Figure 16-4 Serial Operating Mode Register 0 Format.

Figure 6-7. P25, P26 Configurations (μ PD78064Y subseries)



- PUO : Pull-up resistor option register
- PM : Port mode register
- RD : Port 2 read signal
- WR : Port 2 write signal

Figure 6-8. P27 Configuration (μ PD78064Y subseries)



- PUO : Pull-up resistor option register
- PM : Port mode register
- RD : Port 2 read signal
- WR : Port 2 write signal

6.2.5 Port 3

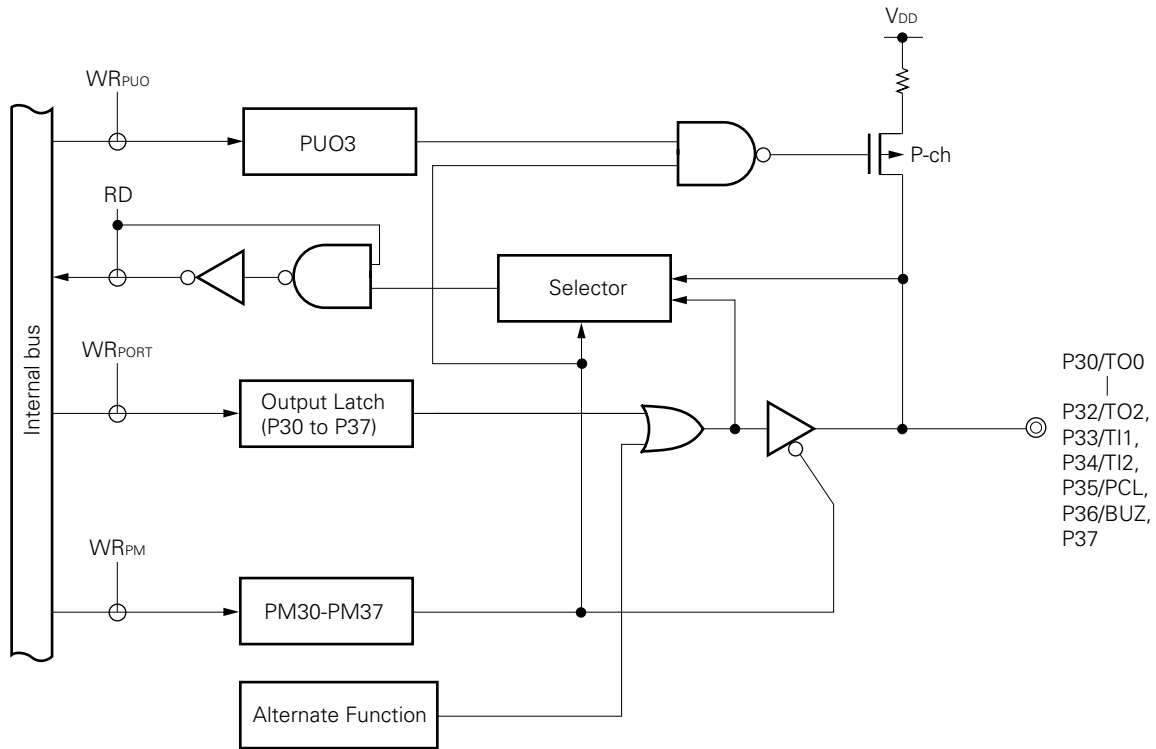
Port 3 is an 8-bit input/output port with output latch. P30 to P37 pins can specify the input mode/output mode in 1-bit units with the port mode register 3. When P30 to P37 pins are used as input ports, a pull-up resistor can be connected to them in 8-bit units with a pull-up resistor option register L.

Dual-functions include timer input/output, clock output and buzzer output.

$\overline{\text{RESET}}$ input sets port 3 to input mode.

Figure 6-9 shows a block diagram of port 3.

Figure 6-9. P30 to P37 Configurations



- PUO : Pull-up resistor option register
- PM : Port mode register
- RD : Port 3 read signal
- WR : Port 3 write signal

6.2.6 Port 7

This is a 3-bit input/output port with output latches. Input mode/output mode can be specified bit-wise by means of port mode register 7. When pins P70 to P72 are used as input port pins, a pull-up resistor can be connected as a 3-bit unit by means of pull-up resistor option register L.

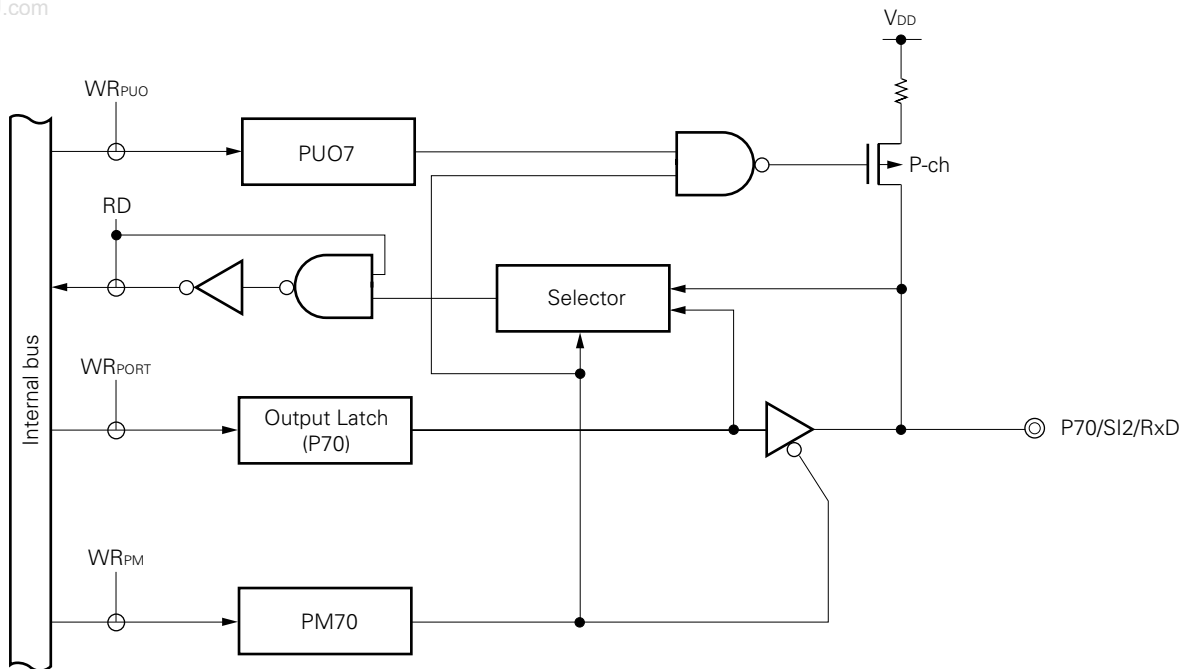
Dual-functions include serial interface channel 2 data input/output and clock input/output.

$\overline{\text{RESET}}$ input sets the input mode.

Port 7 block diagrams are shown in Figures 6-10 and 6-11.

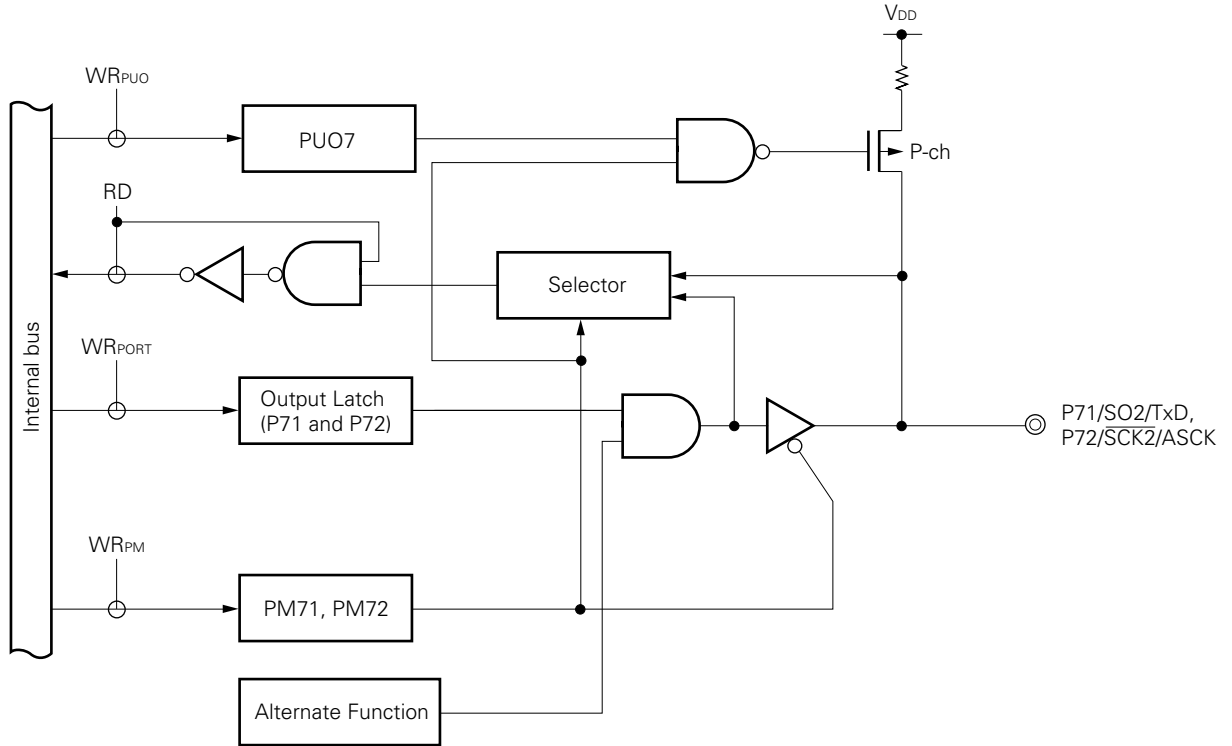
Caution When used as a serial interface, set the input/output and output latch according to its functions. For the setting method, refer to Table 17-2 Serial Interface Channel 2 Operating Mode Setting.

Figure 6-10. P70 Configuration



- PUO : Pull-up resistor option register
- PM : Port mode register
- RD : Port 7 read signal
- WR : Port 7 write signal

Figure 6-11. P71 and P72 Configurations



- PUO : Pull-up resistor option register
- PM : Port mode register
- RD : Port 7 read signal
- WR : Port 7 write signal

www.DataSheet4U.com

6.2.7 Port 8

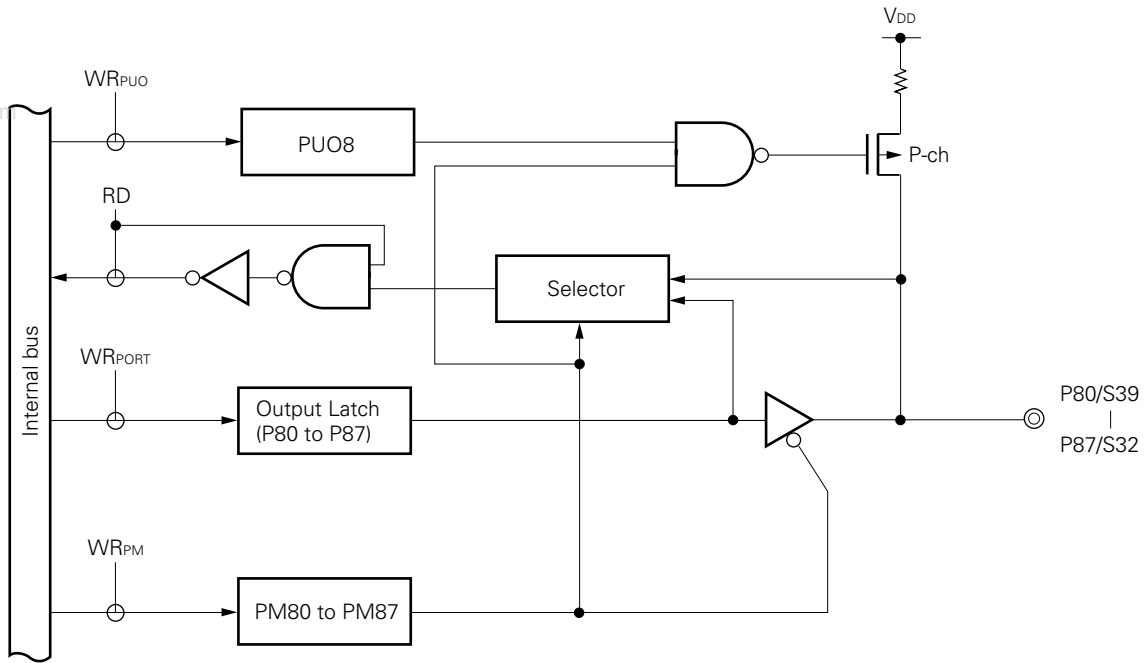
This is an 8-bit input/output port with output latches. Input mode/output mode can be specified bit-wise by means of port mode register 8. When pins P80 to P87 are used as input port pins, a pull-up resistor can be connected as an 8-bit unit by means of pull-up resistor option register H.

These pins are dual-function pins and serve as LCD controller/driver segment signal outputs.

$\overline{\text{RESET}}$ input sets the input mode.

The port 8 block diagram is shown in Figure 6-12.

Figure 6-12. P80 to P87 Configurations



- PUO : Pull-up resistor option register
- PM : Port mode register
- RD : Port 8 read signal
- WR : Port 8 write signal

6.2.8 Port 9

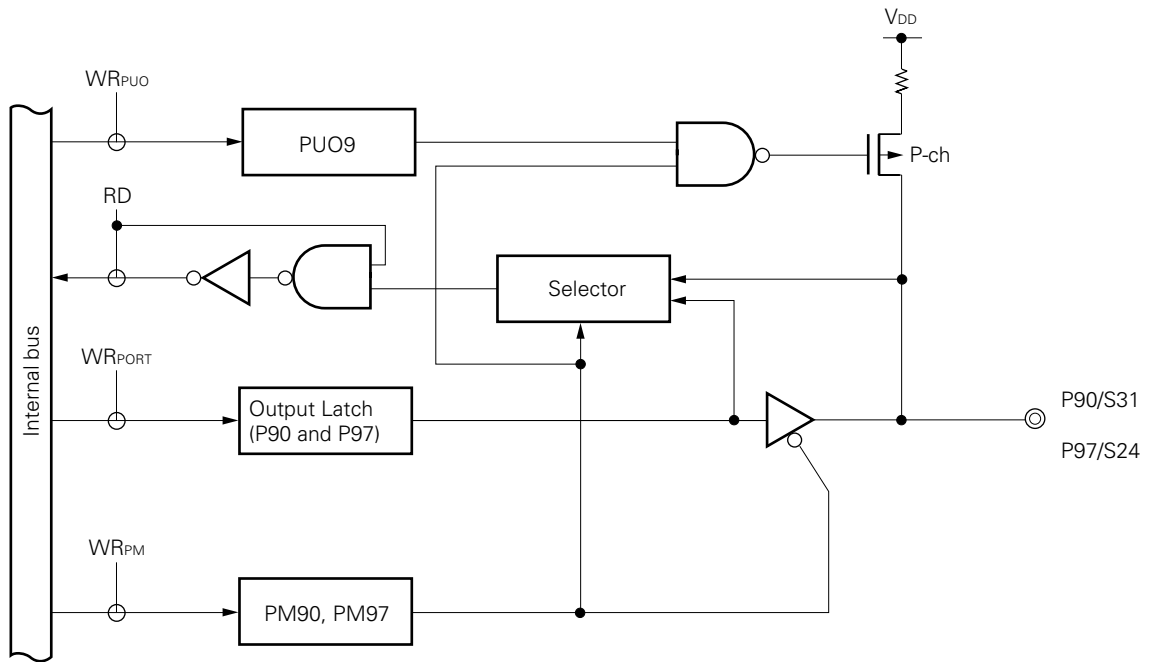
This is a 8-bit input/output port with output latches. Input mode/output mode can be specified bit-wise by means of port mode register 9. When pins P90 and P97 are used as input port pins, a pull-up resistor can be connected as a 8-bit unit by means of pull-up resistor option register H.

These pins are dual-function pins and serve as LCD controller/driver segment signal outputs.

$\overline{\text{RESET}}$ input sets the input mode.

The port 9 block diagram is shown in Figure 6-13.

Figure 6-13. P90 to P97 Configurations



- PUO : Pull-up resistor option register
- PM : Port mode register
- RD : Port 9 read signal
- WR : Port 9 write signal

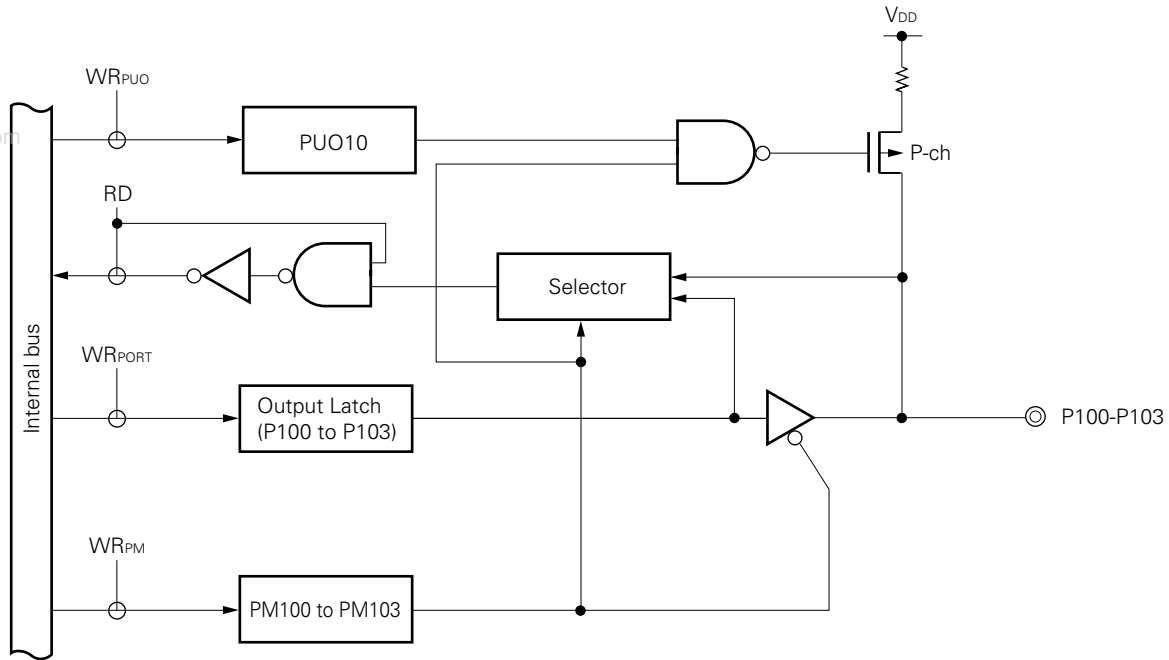
6.2.9 Port 10

This is a 4-bit input/output port with output latches. Input mode/output mode can be specified bit-wise by means of port mode register 10. When pins P100 and P103 are used as input port pins, a pull-up resistor can be connected as a 4-bit unit by means of pull-up resistor option register H.

$\overline{\text{RESET}}$ input sets the input mode.

The port 10 block diagram is shown in Figure 6-14.

Figure 6-14. P100 to P103 Configurations



- PUO : Pull-up resistor option register
- PM : Port mode register
- RD : Port 9 read signal
- WR : Port 9 write signal

6.2.10 Port 11

Port 11 is an 8-bit input/output port with output latches. P110 to P117 pins can specify the input mode/output mode in 8-bit units with the port mode register 11. When they are used as input ports, a pull-up resistor can be connected to them in 8-bit units with pull-up resistor option register H.

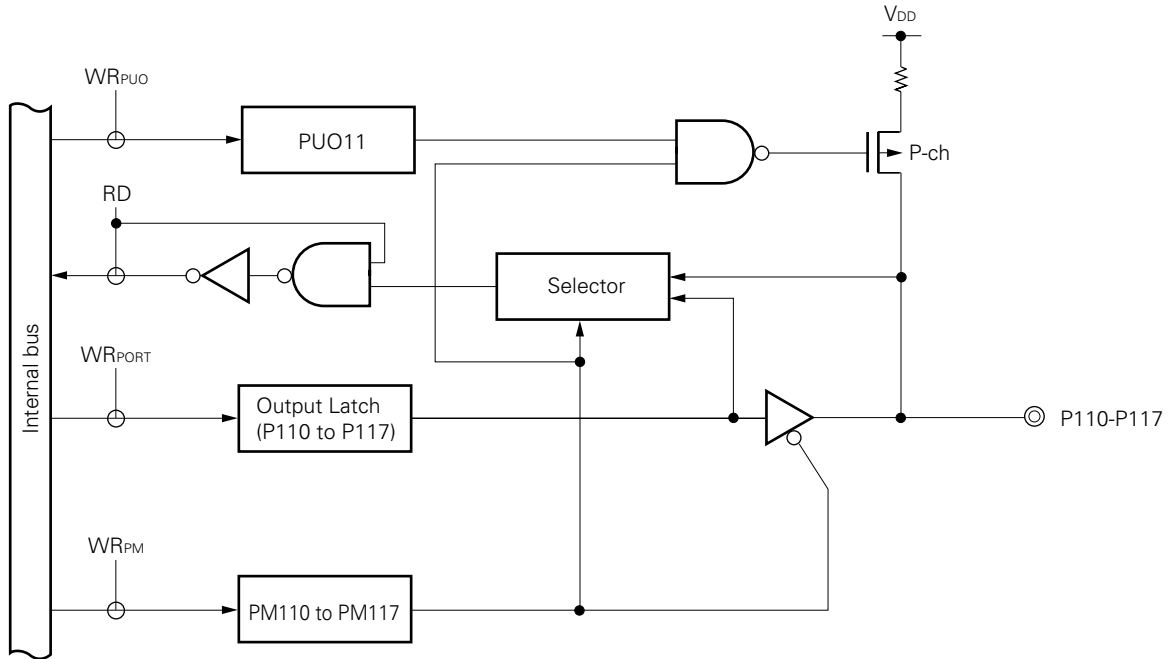
The test input flag (KRIF) can be set to 1 by detecting falling edges.

Dual-functions include address/data bus function in external memory expansion mode.

RESET input sets port 11 to input mode.

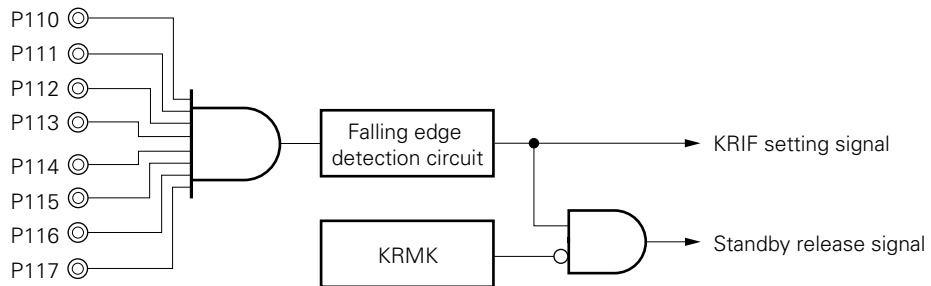
Figures 6-15 and 6-16 show the block diagrams of port 4 and falling edge detection circuit, respectively.

Figure 6-15. P40 to P47 Configurations



- PUO : Pull-up resistor option register
- MM : Memory expansion mode register
- RD : Port 4 read signal
- WR : Port 4 write signal

Figure 6-16. Block Diagram of Falling Edge Detection Circuit



6.3 Port Function Control Registers

The following three types of registers control the ports.

- Port mode registers (PM0 to PM3, PM7 to PM11)
- Pull-up resistor option register (PUOH, PUOL)
- Key return mode register (KRM)

(1) Port mode registers (PM0 to PM3, PM7 to PM11)

These registers are used to set port input/output in 1-bit units.

PM0 to PM3 and PM7 to PM11 are independently set with a 1-bit or 8-bit memory manipulation instruction $\overline{\text{RESET}}$ input sets registers to FFH.

When port pins are used as the dual-function pins, set the port mode register and output latch according to

www.DataSheet4U.com Table 6-4.

Cautions 1. Pins P00 and P07 are input-only pins.

- 2. As port 0 has a dual function as external interrupt input, when the port function output mode is specified and the output level is changed, the interrupt request flag is set. When the output mode is used, therefore, the interrupt mask flag should be set to 1 beforehand.**

Table 6-4. Port Mode Register and Output Latch Settings when Using Dual-Functions

Pin Name	Dual-functions		PM _{xx}	P _{xx}
	Name	Input/Output		
P00	INTP0	Input	1 (Fixed)	None
	TI00	Input	1 (Fixed)	None
P01	INTP1	Input	1	×
	TI01	Input	1	×
P02 to P05	INTP2 to INTP5	Input	1	×
P07 ^{Note1}	XT1	Input	1 (Fixed)	None
P10 to P17 ^{Note1}	ANI0 to ANI7	Input	1	×
P30 to P32	TO0 to TO2	Output	0	0
P33, P34	TI1, TI2	Input	1	×
P35	PCL	Output	0	0
P36	BUZ	Output	0	0
P80 to P87	S39 to S32	Output	× ^{Note2}	
P90 to P97	S31 to S24	Output	× ^{Note2}	

- Notes**
1. If these ports are read out when these pins are used in the alternative function mode, undefined values are read.
 2. When the P80 to P87 and P90 to P97 pins are used for dual functions, set the function by the LCD display control register.

Caution When port 2 and port 7 are used for serial interface, the I/O latch or output latch must be set according to its function. For the setting methods, see Figure 15-4 “Serial Operation Mode Register 0 Format,” Figure 16-4 “Serial Operation Mode Register 0 Format,” and Table 17-2 “Serial Interface Channel 2 Operating Mode Settings.”

Remarks

- × : don't care
- PM_{xx} : port mode register
- P_{xx} : port output latch

Figure 6-17. Port Mode Register Format

Symbol	7	6	5	4	3	2	1	0	Address	After Reset	R/W
PM0	1	1	PM05	PM04	PM03	PM02	PM01	1	FF20H	FFH	R/W
PM1	PM17	PM16	PM15	PM14	PM13	PM12	PM11	PM10	FF21H	FFH	R/W
PM2	PM27	PM26	PM25	1	1	1	1	1	FF22H	FFH	R/W
PM3	PM37	PM36	PM35	PM34	PM33	PM32	PM31	PM30	FF23H	FFH	R/W
PM7	1	1	1	1	1	PM72	PM71	PM70	FF27H	FFH	R/W
PM8	PM87	PM86	PM85	PM84	PM83	PM82	PM81	PM80	FF28H	FFH	R/W
PM9	PM97	PM96	PM95	PM94	PM93	PM92	PM91	PM90	FF29H	FFH	R/W
PM10	1	1	1	1	PM103	PM102	PM101	PM100	FF2AH	FFH	R/W
PM11	PM117	PM116	PM115	PM114	PM113	PM112	PM111	PM110	FF2BH	FFH	R/W

PMmn	Pmn Pin Input/Output Mode Selection (m = 0-3, 7-11 ; n = 0-7)
0	Output mode (output buffer ON)
1	Input mode (output buffer OFF)

*

www.DataSheet4U.com

(2) Pull-up resistor option register (PUOH, PUOL)

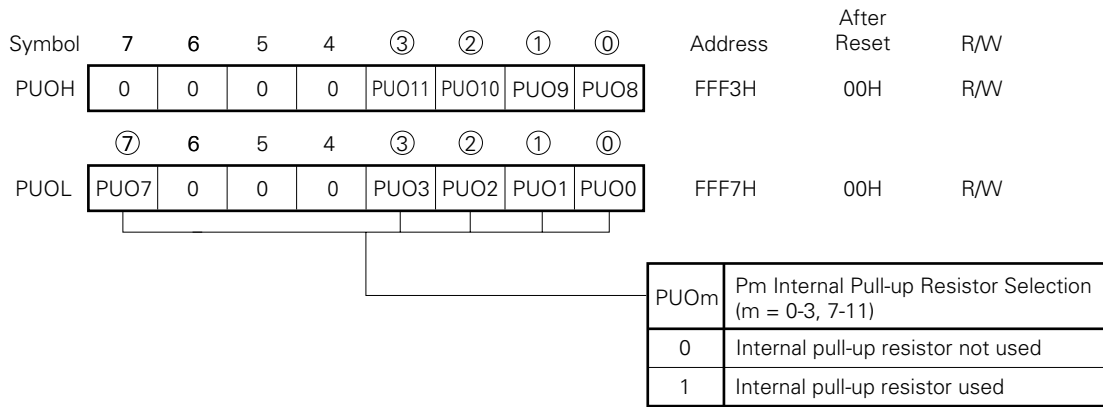
This register is used to set whether to use an internal pull-up resistor at each port or not. A pull-up resistor is internally used at bits which are set to the input mode at a port where pull-up resistor use has been specified with PUOH, PUOL. No pull-up resistors can be used to the bits set to the output mode or to the bits used as an analog input pin, irrespective of PUOH or PUOL setting.

PUOH and PUOL are set with a 1-bit or 8-bit memory manipulation instruction.

RESET input sets this register to 00H.

- Cautions**
- P00 and P07 pins do not incorporate a pull-up resistor.**
 - When ports 1, 8, and 9 are used as dual-function pins, a pull-up resistor cannot be used even if 1 is set in PUOm (m = 1, 8, 9).**

Figure 6-18. Pull-Up Resistor Option Register Format



Caution Zeros must be set to bits 4 to 7 of PUOH and bit 4 to 6 of PUOL.

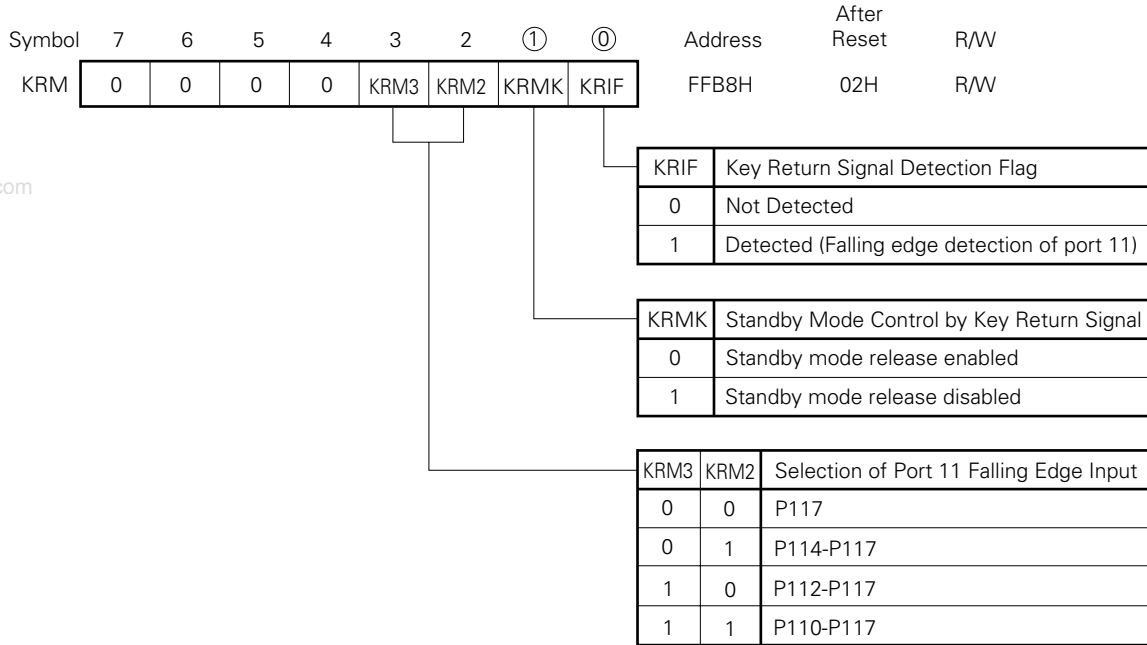
(3) Key return mode register (KRM)

This register sets enabling/disabling of standby function release by a key return signal (falling edge detection of port 11), and selects the port 11 falling edge input.

KRM is set with a 1-bit or 8-bit memory manipulation instruction.

RESET input sets KRM to 02H.

Figure 6-19. Key Return Mode Register Format



Caution When falling edge detection of port 11 is used, KRIF should be cleared to 0 (not cleared to 0 automatically).

6.4 Port Function Operations

Port operations differ depending on whether the input or output mode is set, as shown below.

6.4.1 Writing to input/output port

(1) Output mode

A value is written to the output latch by a transfer instruction, and the output latch contents are output from the pin.

Once data is written to the output latch, it is retained until data is written to the output latch again.

(2) Input mode

A value is written to the output latch by a transfer instruction, but since the output buffer is OFF, the pin status does not change.

Once data is written to the output latch, it is retained until data is written to the output latch again.

Caution In the case of 1-bit memory manipulation instruction, although a single bit is manipulated the port is accessed as an 8-bit unit. Therefore, on a port with a mixture of input and output pins, the output latch contents for pins specified as input are undefined except for the manipulated bit.

6.4.2 Reading from input/output port

(1) Output mode

The output latch contents are read by a transfer instruction. The output latch contents do not change.

(2) Input mode

The pin status is read by a transfer instruction. The output latch contents do not change.

6.4.3 Operations on input/output port

(1) Output mode

An operation is performed on the output latch contents, and the result is written to the output latch. The output latch contents are output from the pins.

Once data is written to the output latch, it is retained until data is written to the output latch again.

(2) Input mode

The output latch contents are undefined, but since the output buffer is OFF, the pin status does not change.

Caution In the case of 1-bit memory manipulation instruction, although a single bit is manipulated the port is accessed as an 8-bit unit. Therefore, on a port with a mixture of input and output pins, the output latch contents for pins specified as input are undefined, even for bits other than the manipulated bit.

[MEMO]

www.DataSheet4U.com

CHAPTER 7 CLOCK GENERATOR

7.1 Clock Generator Functions

The clock generator generates the clock to be supplied to the CPU and peripheral hardware. The following two types of system clock oscillators are available.

(1) Main system clock oscillator

This circuit oscillates at frequencies of 1 to 5.0 MHz. Oscillation can be stopped by executing the STOP instruction or setting the processor clock control register.

(2) Subsystem clock oscillator

The circuit oscillates at a frequency of 32.768 kHz. Oscillation cannot be stopped. If the subsystem clock oscillator is not used, not using the internal feedback resistance can be set by the processor clock control register. This enables to decrease power consumption in the STOP mode.

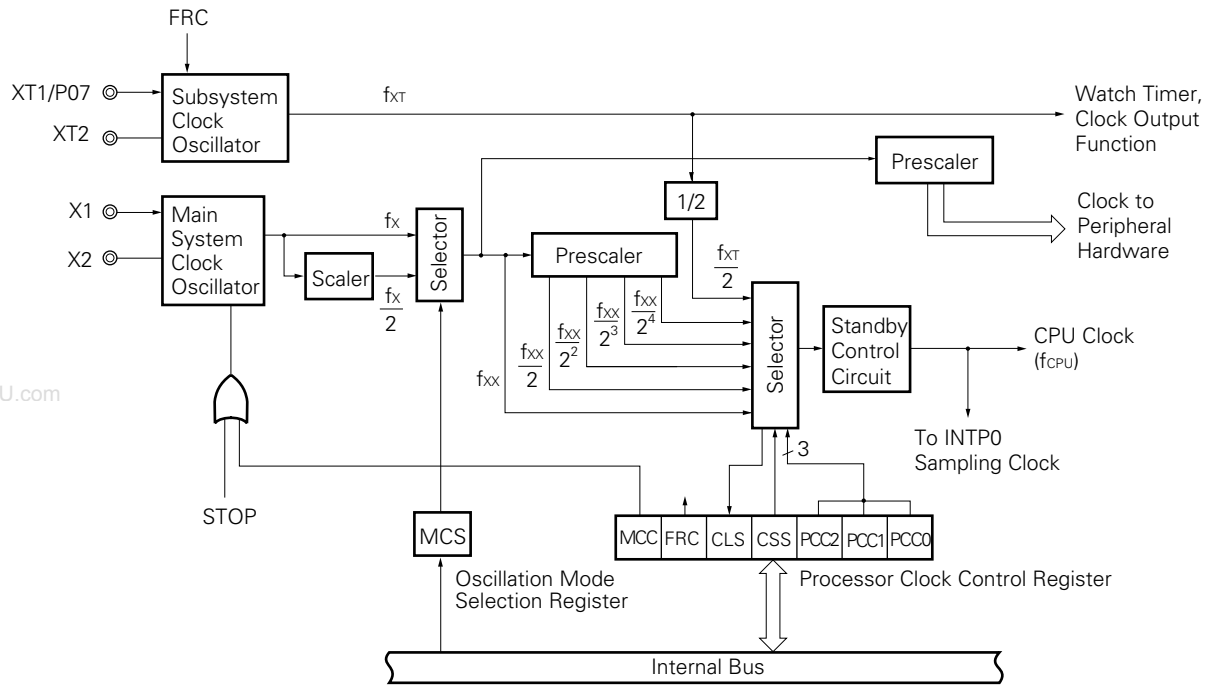
7.2 Clock Generator Configuration

The clock generator consists of the following hardware.

Table 7-1. Clock Generator Configuration

Item	Configuration
Control register	Processor clock control register (PCC) Oscillation mode selection register (OSMS)
Oscillator	Main system clock oscillator Subsystem clock oscillator

Figure 7-1. Block Diagram of Clock Generator



www.DataSheet4U.com

7.3 Clock Generator Control Register

The clock generator is controlled by the following two registers:

- Processor clock control register (PCC)
- Oscillation mode selection register (OSMS)

(1) Processor clock control register (PCC)

The PCC sets whether to use CPU clock selection, the ratio of division, main system clock oscillator operation/stop and subsystem clock oscillator internal feedback resistor.

The PCC is set with a 1-bit or 8-bit memory manipulation instruction.

$\overline{\text{RESET}}$ input sets the PCC to 04H.

www.DataSheet4U.com

Figure 7-2. Subsystem Clock Feedback Resistor

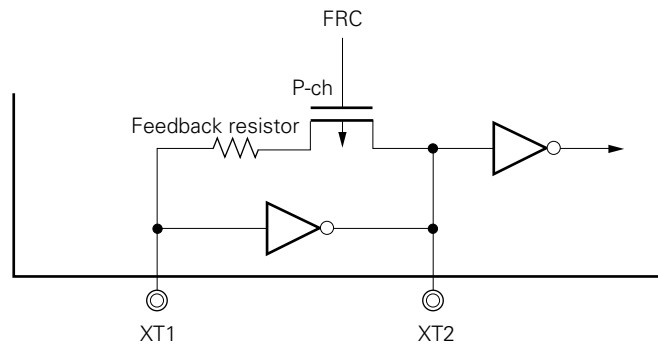


Figure 7-3. Processor Clock Control Register Format

Symbol	⑦	⑥	⑤	④	3	2	1	0	Address	After Reset	R/W
PCC	MCC	FRC	CLS	CSS	0	PCC2	PCC1	PCC0	FFFBH	04H	R/W ^{Note 1}

R/W	CSS	PCC2	PCC1	PCC0	CPU Clock Selection (f_{CPU})		
					MCS=1		MCS=0
	0	0	0	0	f_{xx}	f_x (0.4 μs)	$f_x/2$ (0.8 μs)
		0	0	1	$f_{xx}/2$	$f_x/2$ (0.8 μs)	$f_x/2^2$ (1.6 μs)
		0	1	0	$f_{xx}/2^2$	$f_x/2^2$ (1.6 μs)	$f_x/2^3$ (3.2 μs)
		0	1	1	$f_{xx}/2^3$	$f_x/2^3$ (3.2 μs)	$f_x/2^4$ (6.4 μs)
		1	0	0	$f_{xx}/2^4$	$f_x/2^4$ (6.4 μs)	$f_x/2^5$ (12.8 μs)
	1	0	0	0	$f_{xt}/2$ (122 μs)		
		0	0	1			
		0	1	0			
0		1	1				
1		0	0				
Other than above				Setting prohibited			

R	CLS	CPU Clock Status
	0	Main system clock
	1	Subsystem clock

R/W	FRC	Subsystem Clock Feedback Resistor Selection
	0	Internal feedback resistor used
	1	Internal feedback resistor not used

R/W	MCC	Main System Clock Oscillation Control ^{Note 2}
	0	Oscillation possible
	1	Oscillation stopped

Notes 1. Bit 5 is Read Only.

2. When the CPU is operating on the subsystem clock, MCC should be used to stop the main system clock oscillation. A STOP instruction should not be used.

Caution Bit 3 must be set to 0.

- Remarks**
- f_{xx} : Main system clock frequency (f_x or $f_x/2$)
 - f_x : Main system clock oscillation frequency
 - f_{xt} : Subsystem clock oscillation frequency
 - MCS : Bit 0 of oscillation mode selection register
 - Figures in parentheses indicate minimum instruction execution time : $2f_{CPU}$ when operating at $f_x = 5.0$ MHz or $f_{xt} = 32.768$ kHz.

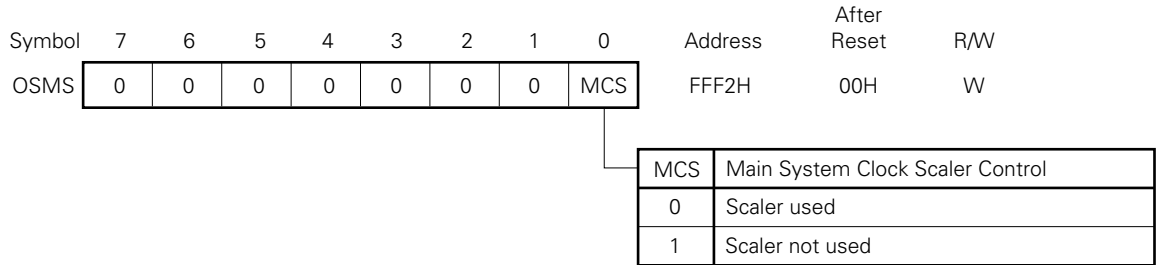
(2) Oscillation mode selection register (OSMS)

This register specifies whether the clock output from the main system clock oscillator without passing through the scaler is used as the main system clock, or the clock output via the scaler is used as the main system clock.

OSMS is set with 8-bit memory manipulation instruction.

$\overline{\text{RESET}}$ input sets OSMS to 00H.

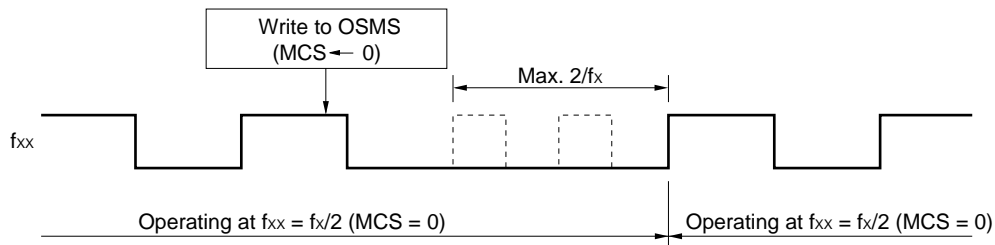
Figure 7-4. Oscillation Mode Selection Register Format



www.DataSheet4U.com

- Cautions**
1. **Writing to OSMS should be performed only immediately after reset signal release and before peripheral hardware operation starts. As shown in Figure 7-5 below, writing data (including same data as previous) to OSMS cause delay of main system clock cycle up to $2/f_x$ during the write operation. Therefore, if this register is written during the operation, in peripheral hardware which operates with the main system clock, a temporary error occurs in the count clock cycle of timer, etc. In addition, because the oscillation mode is changed by this register, the clocks for peripheral hardware as well as that for the CPU are switched.** *
 2. **When writing "1" to MCS, V_{DD} must be 2.7 V or higher before the write execution.**

Figure 7-5. Main System Clock Waveform due to Writing to OSMS



Remark f_{xx} : Main system clock frequency (f_x or $f_x/2$)
 f_x : Main system clock oscillation frequency

7.4 System Clock Oscillator

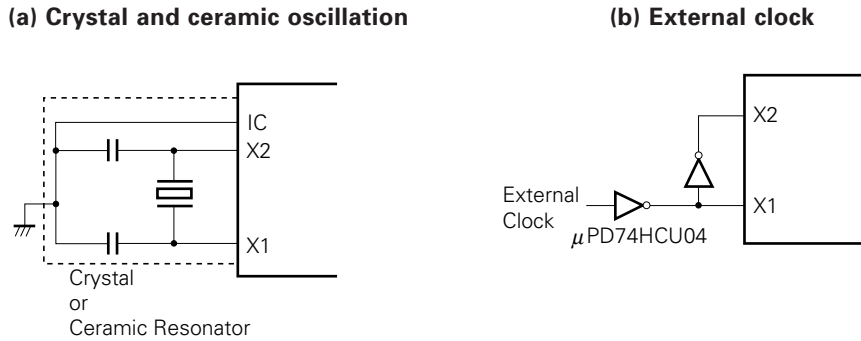
7.4.1 Main system clock oscillator

The main system clock oscillator oscillates with a crystal resonator or a ceramic resonator (standard: 5.0 MHz) connected to the X1 and X2 pins.

External clocks can be input to the main system clock oscillator. In this case, input a clock signal to the X1 pin and an antiphase clock signal to the X2 pin.

Figure 7-6 shows an external circuit of the main system clock oscillator.

Figure 7-6. External Circuit of Main System Clock Oscillator



- * **Caution** Do not execute the STOP instruction or do not set MCC to 1 if an external clock is used. This is because the X2 pin is connected to V_{DD} via a pull-up resistor.

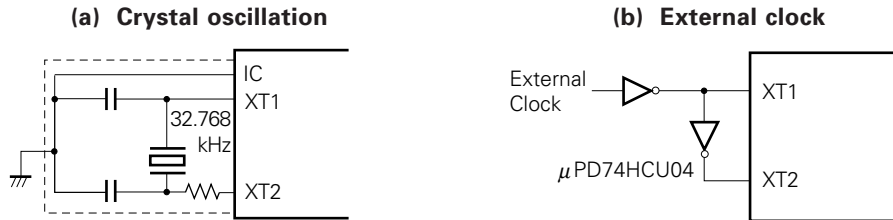
7.4.2 Subsystem clock oscillator

The subsystem clock oscillator oscillates with a crystal resonator (standard: 32.768 kHz) connected to the XT1 and XT2 pins.

External clocks can be input to the subsystem clock oscillator. In this case, input a clock signal to the XT1 pin and an antiphase clock signal to the XT2 pin.

Figure 7-7 shows an external circuit of the subsystem clock oscillator.

Figure 7-7. External Circuit of Subsystem Clock Oscillator



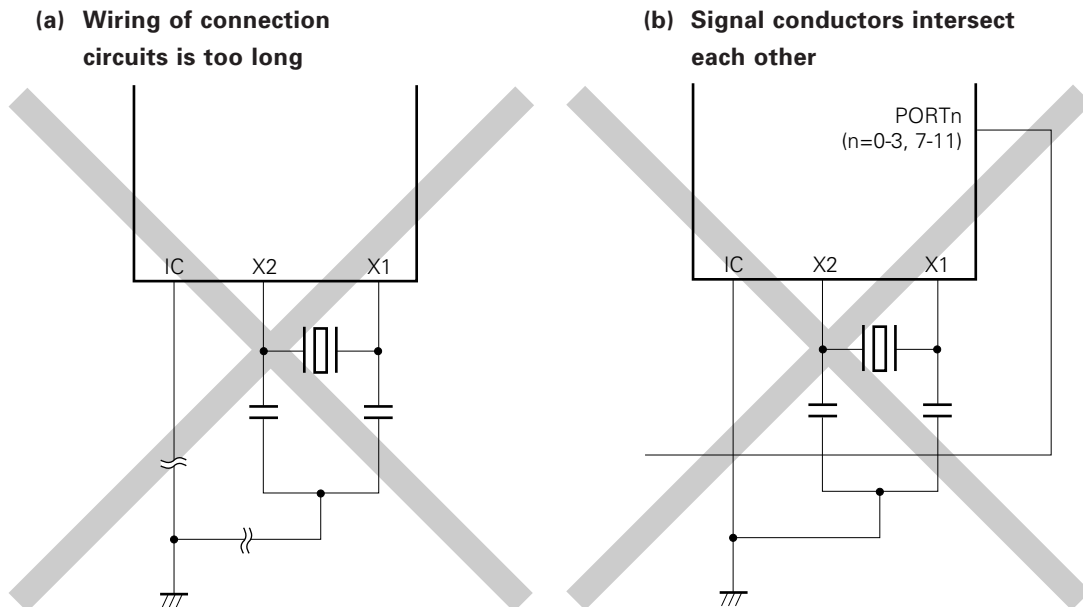
Cautions 1. When using a main system clock oscillator and a subsystem clock oscillator, carry out wiring in the broken line area in Figures 7-6 and 7-7 to prevent any effects from wiring capacities.

- Minimize the wiring length.
- Do not allow wiring to intersect with other signal conductors. Do not allow wiring to come near changing high current.
- Set the potential of the grounding position of the oscillator capacitor to that of V_{SS}. Do not ground to any ground pattern where high current is present.
- Do not fetch signals from the oscillator.

Take special note of the fact that the subsystem clock oscillator is a circuit with low-level amplification so that current consumption is maintained at low levels.

Figure 7-8 shows examples of oscillator having bad connection.

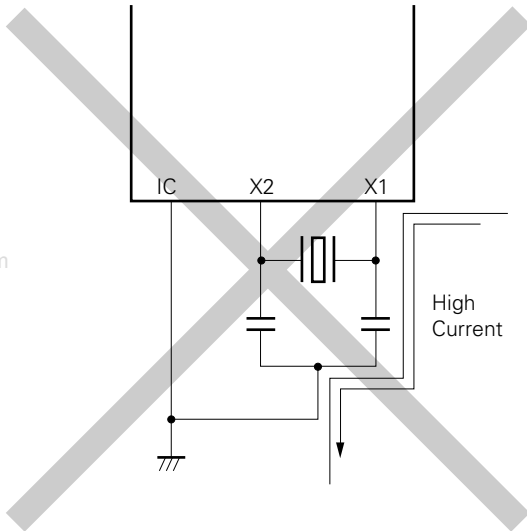
Figure 7-8. Examples of Oscillator with Bad Connection (1/2)



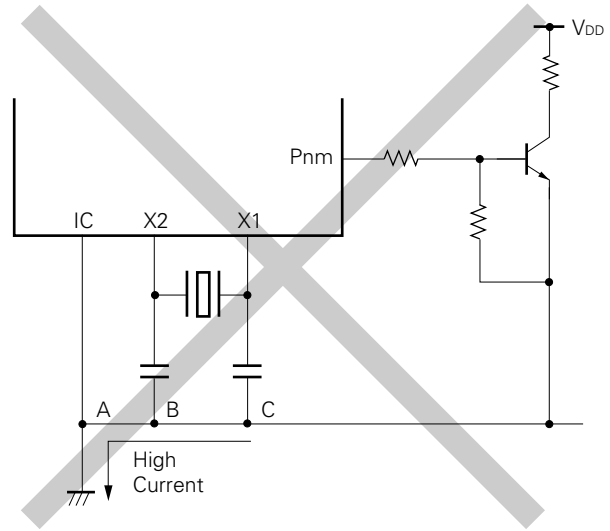
Remark When using a subsystem clock, replace X1 and X2 with XT1 and XT2, respectively. Further, insert resistors in series on the side of XT2.

Figure 7-8. Examples of Oscillator with Bad Connection (2/2)

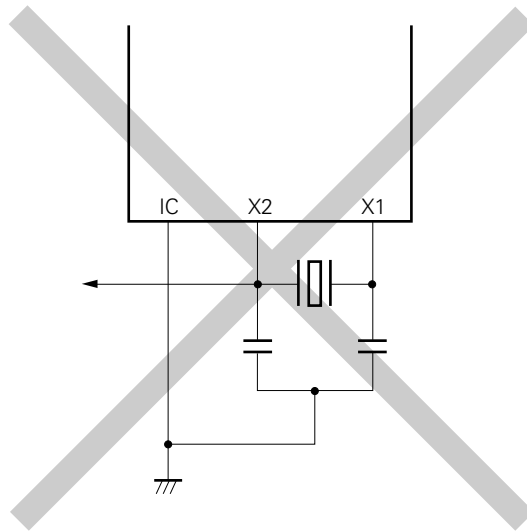
(c) Changing high current is too near a signal conductor



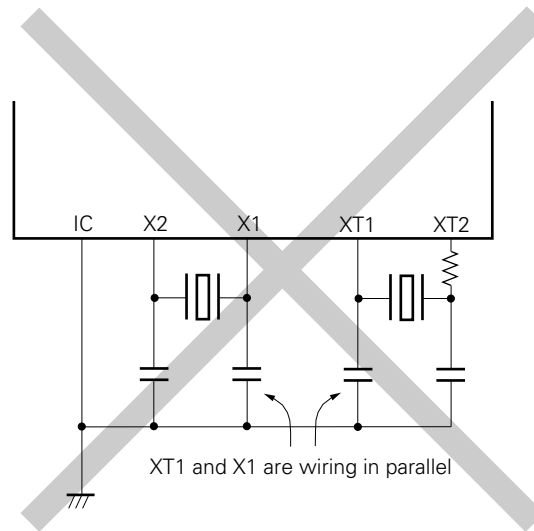
(d) Current flows through the grounding line of the oscillator (potential at points A, B, and C fluctuate)



(e) Signals are fetched



(f) Signal conductors of the main and sub system clocks are parallel and near each other



Remark When using a subsystem clock, replace X1 and X2 with XT1 and XT2, respectively. Also, insert resistors in series on the XT2 side.

Cautions 2. In Figure 7-8 (f), XT1 and X1 are wired in parallel. Thus, the cross-talk noise of X1 may increase with XT1, resulting in malfunctioning. To prevent that from occurring, it is recommended to wire XT1 and X1 so that they are not in parallel.

7.4.3 Scaler

The scaler divides the main system clock oscillator output (f_{xx}) and generates various clocks.

7.4.4 When no subsystem clocks are used

If it is not necessary to use subsystem clocks for low power consumption operations and clock operations, connect the XT1 and XT2 pins as follows.

- * XT1 : Connect to V_{DD}
- XT2 : Open

In this state, however, some current may leak via the internal feedback resistor of the subsystem clock oscillator when the main system clock stops. To minimize leakage current, the above internal feedback resistance can be removed with bit 6 (FRC) of the processor clock control register. In this case also, connect the XT1 and XT2 pins as described above.

7.5 Clock Generator Operations

The clock generator generates the following various types of clocks and controls the CPU operating mode including the standby mode.

- Main system clock f_{xx}
- Subsystem clock f_{xt}
- CPU clock f_{CPU}
- Clock to peripheral hardware

The following clock generator functions and operations are determined with the processor clock control register (PCC) and the oscillation mode selection register (OSMS).

www.DataSheet4U.com

- (a) Upon generation of $\overline{\text{RESET}}$ signal, the lowest speed mode of the main system clock ($12.8 \mu\text{s}$ when operated at 5.0 MHz) is selected (PCC = 04H, OSMS = 00H). Main system clock oscillation stops while low level is applied to $\overline{\text{RESET}}$ pin.
- (b) With the main system clock selected, one of the six CPU clock types ($0.4 \mu\text{s}$, $0.8 \mu\text{s}$, $1.6 \mu\text{s}$, $3.2 \mu\text{s}$, $6.4 \mu\text{s}$, $12.8 \mu\text{s}$ @ 5.0 MHz) can be selected by setting the PCC and OSMS.
- (c) With the main system clock selected, two standby modes, the STOP and HALT modes, are available. To decrease current consumption in the STOP mode, the subsystem clock feedback resistor can be disconnected to stop the subsystem clock.
- (d) The PCC can be used to select the subsystem clock and to operate the system with low current consumption ($122 \mu\text{s}$ when operated at 32.768 kHz).
- (e) With the subsystem clock selected, main system clock oscillation can be stopped with the PCC. The HALT mode can be used. However, the STOP mode cannot be used. (Subsystem clock oscillation cannot be stopped.)
- (f) The main system clock is divided and supplied to the peripheral hardware. The subsystem clock is supplied to 16-bit timer/event counter, the watch timer, and clock output functions only. Thus, 16-bit timer/event counter (when selecting watch timer output for count clock operating with subsystem clock), the watch function, and the clock output function can also be continued in the standby state. However, since all other peripheral hardware operate with the main system clock, the peripheral hardware also stops if the main system clock is stopped. (Except external input clock operation)

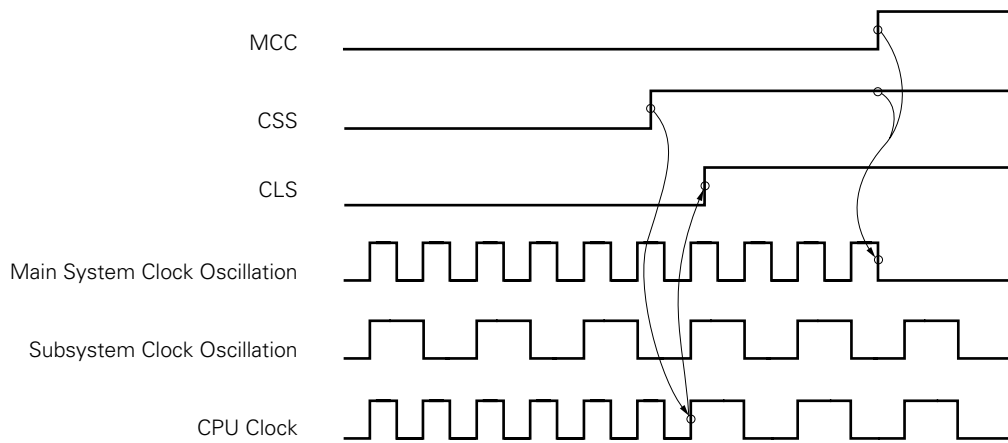
7.5.1 Main system clock operations

When operated with the main system clock (with bit 5 (CLS) of the processor clock control register (PCC) set to 0), the following operations are carried out by PCC setting.

- (a) Because the operation guarantee instruction execution speed depends on the power supply voltage, the instruction execution time can be changed by bit 0 to bit 2 (PCC0 to PCC2) of the PCC.
- (b) If bit 7 (MCC) of the PCC is set to 1 when operated with the main system clock, the main system clock oscillation does not stop. When bit 4 (CSS) of the PCC is set to 1 and the operation is switched to subsystem clock operation (CLS = 1) after that, the main system clock oscillation stops (see **Figure 7-9**).

Figure 7-9. Main System Clock Stop Function (1/2)

(a) Operation when MCC is set after setting CSS with main system clock operation



(b) Operation when MCC is set in case of main system clock operation

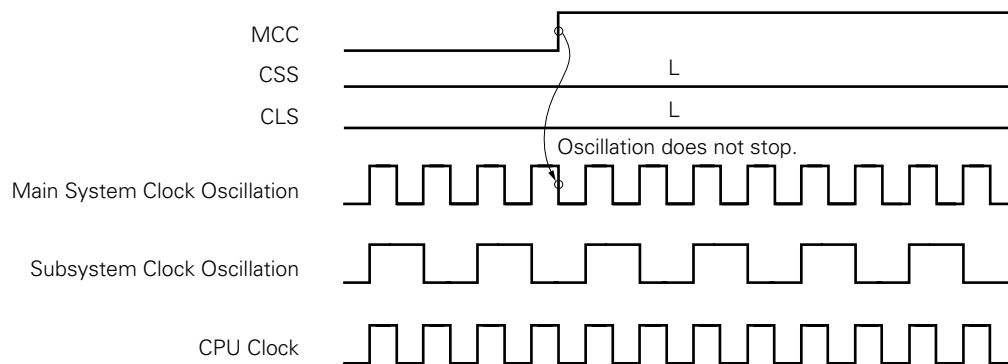
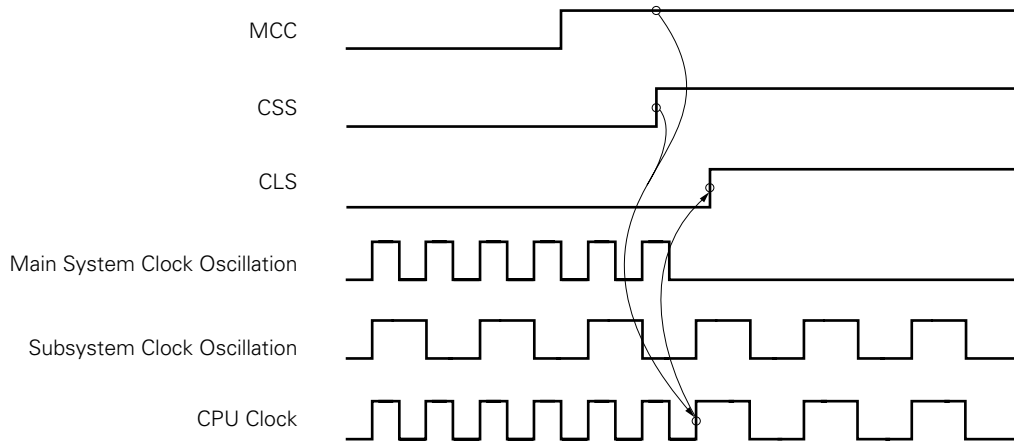


Figure 7-9. Main System Clock Stop Function (2/2)

(c) Operation when CSS is set after setting MCC with main system clock operation



7.5.2 Subsystem clock operations

When operated with the subsystem clock (with bit 5 (CLS) of the processor clock control register (PCC) set to 1), the following operations are carried out.

- The instruction execution time remains constant ($122 \mu\text{s}$ when operated at 32.768 kHz) irrespective of bit 0 to bit 2 (PCC0 to PCC2) of the PCC.
- Watchdog timer counting stops.

Caution Do not execute the STOP instruction while the subsystem clock is in operation.

7.6 Changing System Clock and CPU Clock Settings

7.6.1 Time required for switchover between system clock and CPU clock

The system clock and CPU clock can be switched over by means of bit 0 to bit 2 (PCC0 to PCC2) and bit 4 (CSS) of the processor clock control register (PCC).

The actual switchover operation is not performed directly after writing to the PCC, but operation continues on the pre-switchover clock for several instructions (see **Table 7-2**).

Determination as to whether the system is operating on the main system clock or the subsystem clock is performed by bit 5 (CLS) of the PCC register.

Table 7-2. Maximum Time Required for CPU Clock Switchover

Set Values after Switchover					Set Values before Switchover																									
MCS	CSS	PCC2	PCC1	PCC0	CSS	PCC2	PCC1	PCC0	CSS	PCC2	PCC1	PCC0	CSS	PCC2	PCC1	PCC0	CSS	PCC2	PCC1	PCC0	CSS	PCC2	PCC1	PCC0						
					0	0	0	0	0	0	0	1	0	0	1	0	0	0	1	1	0	1	0	0	1	X	X	X		
X	0	0	0	0	8 instructions		4 instructions		2 instructions		1 instruction		1 instruction																	
		0	0	1	16 instructions		4 instructions		2 instructions		1 instruction		1 instruction																	
		0	1	0	16 instructions		8 instructions		2 instructions		1 instruction		1 instruction																	
		0	1	1	16 instructions		8 instructions		4 instructions		1 instruction		1 instruction																	
		1	0	0	16 instructions		8 instructions		4 instructions		2 instructions		1 instruction		1 instruction															
1	1	X	X	X	fx/2fxT instruction (77 instructions)		fx/4fxT instruction (39 instructions)		fx/8fxT instruction (20 instructions)		fx/16fxT instruction (10 instructions)		fx/32fxT instruction (5 instructions)																	
					0	fx/4fxT instruction (39 instructions)		fx/8fxT instruction (20 instructions)		fx/16fxT instruction (10 instructions)		fx/32fxT instruction (5 instructions)		fx/64fxT instruction (3 instructions)																

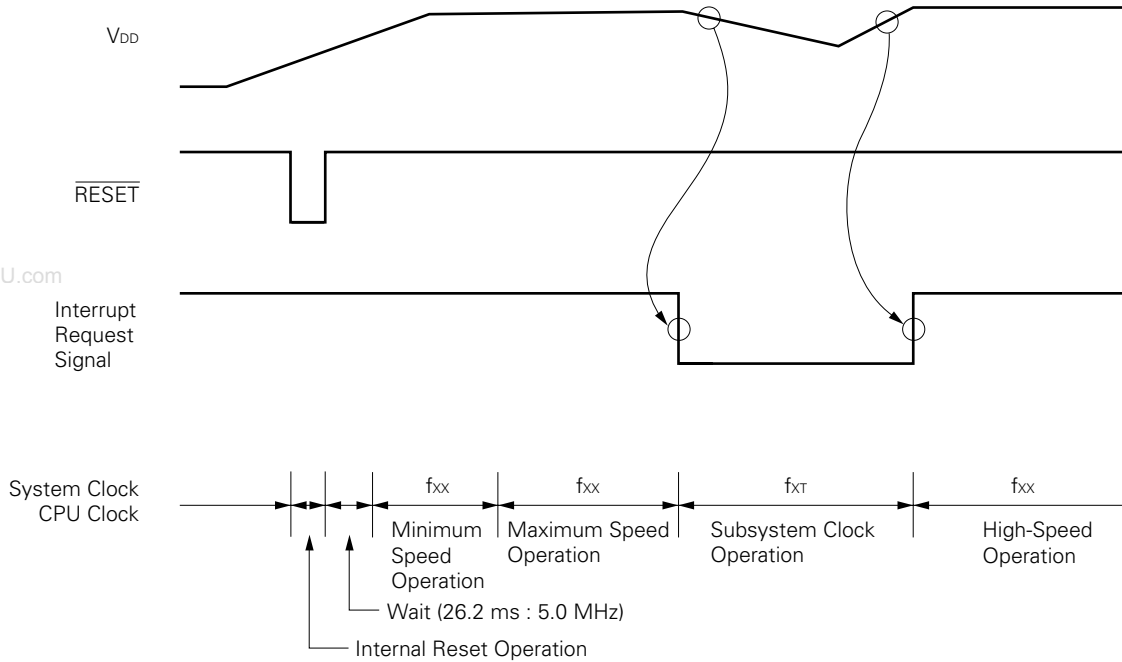
Caution Selection of the CPU clock cycle scaling factor (PCC0 to PCC2) and switchover from the main system clock to the subsystem clock (changing CSS from 0 to 1) should not be performed simultaneously. Simultaneous setting is possible, however, for selection of the CPU clock cycle scaling factor (PCC0 to PCC2) and switchover from the subsystem clock to the main system clock (changing CSS from 1 to 0).

- Remarks**
- One instruction is the minimum instruction execution time with the pre-switchover CPU clock.
 - Figures in parentheses apply to operation with $f_x = 5.0$ MHz and $f_{XT} = 32.768$ kHz.

7.6.2 System clock and CPU clock switching procedure

This section describes switching procedure between system clock and CPU clock.

Figure 7-10. System Clock and CPU Clock Switching



- (1) The CPU is reset by setting the \overline{RESET} signal to low level after power-on. After that, when reset is released by setting the \overline{RESET} signal to high level, main system clock starts oscillation. At this time, oscillation stabilization time ($2^{17}/f_x$) is secured automatically. After that, the CPU starts executing the instruction at the minimum speed of the main system clock (12.8 μ s when operated at 5.0 MHz).
- (2) After the lapse of a sufficient time for the V_{DD} voltage to increase to enable operation at maximum speeds, the PCC and OSMS are rewritten and the maximum-speed operation is carried out.
- (3) Upon detection of a decrease of the V_{DD} voltage due to an interrupt, the main system clock is switched to the subsystem clock (which must be in an oscillation stable state).
- (4) Upon detection of V_{DD} voltage reset due to an interrupt, 0 is set to the MCC and oscillation of the main system clock is started. After the lapse of time required for stabilization of oscillation, the PCC and OSMS are rewritten and the maximum-speed operation is resumed.

Caution When subsystem clock is being operated while main system clock was stopped, if switching to the main system clock is made again, be sure to switch after securing oscillation stable time by software.

CHAPTER 8 16-BIT TIMER/EVENT COUNTER

The timers incorporated into the μ PD78064 and 78064Y subseries are outlined below.

(1) 16-bit timer/event counter (TM0)

The TM0 can be used for an interval timer, PWM output, pulse widths measurement (infrared ray remote control receive function), external event counter, square wave output of any frequency or one-shot pulse output.

(2) 8-bit timers/event counters 1 and 2 (TM1 and TM2)

TM1 and TM2 can be used to serve as an interval timer and an external event counter and to output square waves with any selected frequency. Two 8-bit timer/event counters can be used as one 16-bit timer/event counter (See **CHAPTER 9 8-BIT TIMER/EVENT COUNTERS 1 AND 2**).

(3) Watch timer (TM3)

This timer can set a flag every 0.5 sec. and simultaneously generates interrupts at the preset time intervals (See **CHAPTER 10 WATCH TIMER**).

(4) Watchdog timer (WDTM)

WDTM can perform the watchdog timer function or generate non-maskable interrupts, maskable interrupts and $\overline{\text{RESET}}$ at the preset time intervals (See **CHAPTER 11 WATCHDOG TIMER**).

(5) Clock output control circuit

This circuit supplies other devices with the divided main system clock and the subsystem clock (See **CHAPTER 12 CLOCK OUTPUT CONTROL CIRCUIT**).

(6) Buzzer output control circuit

This circuit outputs the buzzer frequency obtained by dividing the main system clock (See **CHAPTER 13 BUZZER OUTPUT CONTROL CIRCUIT**).

Table 8-1. Timer/Event Counter Types and Functions

		16-bit Timer/ event Counter	8-bit Timer/event Counters 1 and 2	Watch Timer	Watchdog Timer
Type	Interval timer	2 channels ^{Note1}	2 channels	1 channel ^{Note2}	1 channel ^{Note3}
	External event counter	√	√	—	—
Function	Timer output	√	√	—	—
	PWM output	√	—	—	—
	Pulse width measurement	√	—	—	—
	Square-wave output	√	√	—	—
	One-shot pulse output	√	—	—	—
	Interrupt request	√	√	√	√
	Test input	—	—	√	—

- Notes**
1. When capture/compare registers (CR00, CR01) are specified as compare registers.
 2. TM3 can perform both watch timer and interval timer functions at the same time.
 3. WDTM can perform either the watchdog timer function or the interval timer function.

8.1 16-Bit Timer/Event Counter Functions

The 16-bit timer/event counter (TM0) has the following functions.

- Interval timer
- PWM output
- Pulse width measurement
- External event counter
- Square-wave output
- One-shot pulse output

(1) Interval timer

TM0 generates interrupts at the preset time interval.

Table 8-2. 16-Bit Timer/Event Counter Interval Times

Minimum Interval Time		Maximum Interval Time		Resolution	
MCS = 1	MCS = 0	MCS = 1	MCS = 0	MCS = 1	MCS = 0
2 × TI00 input cycle		2 ¹⁶ × TI00 input cycle		TI00 input edge cycle	
—	2 × 1/fx (400 ns)	—	2 ¹⁶ × 1/fx (13.1 ms)	—	1/fx (200 ns)
2 × 1/fx (400 ns)	2 ² × 1/fx (800 ns)	2 ¹⁶ × 1/fx (13.1 ms)	2 ¹⁷ × 1/fx (26.2 ms)	1/fx (200 ns)	2 × 1/fx (400 ns)
2 ² × 1/fx (800 ns)	2 ³ × 1/fx (1.6 μs)	2 ¹⁷ × 1/fx (26.2 ms)	2 ¹⁸ × 1/fx (52.4 ms)	2 × 1/fx (400 ns)	2 ² × 1/fx (800 ns)
2 ³ × 1/fx (1.6 μs)	2 ⁴ × 1/fx (3.2 μs)	2 ¹⁸ × 1/fx (52.4 ms)	2 ¹⁹ × 1/fx (104.9 ms)	2 ² × 1/fx (800 ns)	2 ³ × 1/fx (1.6 μs)
2 × watch timer output cycle		2 ¹⁶ × watch timer output cycle		Watch timer output edge cycle	

- Remarks**
1. fx: Main system clock oscillation frequency
 2. MCS: Oscillation mode selection register bit 0
 3. Values in parentheses when operated at fx = 5.0 MHz

(2) PWM output

TM0 can generate 14-bit resolution PWM output.

(3) Pulse width measurement

TM0 can measure the pulse width of an externally input signal.

(4) External event counter

TM0 can measure the number of pulses of an externally input signal.

(5) Square-wave output

TM0 can output a square wave with any selected frequency.

Table 8-3. 16-Bit Timer/Event Counter Square-Wave Output Ranges

Minimum Pulse Width		Maximum Pulse Width		Resolution	
MCS = 1	MCS = 0	MCS = 1	MCS = 0	MCS = 1	MCS = 0
2 × TI00 input cycle		2 ¹⁶ × TI00 input cycle		TI00 input edge cycle	
—	2 × 1/f _x (400 ns)	—	2 ¹⁶ × 1/f _x (13.1 ms)	—	1/f _x (200 ns)
2 × 1/f _x (400 ns)	2 ² × 1/f _x (800 ns)	2 ¹⁶ × 1/f _x (13.1 ms)	2 ¹⁷ × 1/f _x (26.2 ms)	1/f _x (200 ns)	2 × 1/f _x (400 ns)
2 ² × 1/f _x (800 ns)	2 ³ × 1/f _x (1.6 μs)	2 ¹⁷ × 1/f _x (26.2 ms)	2 ¹⁸ × 1/f _x (52.4 ms)	2 × 1/f _x (400 ns)	2 ² × 1/f _x (800 ns)
2 ³ × 1/f _x (1.6 μs)	2 ⁴ × 1/f _x (3.2 μs)	2 ¹⁸ × 1/f _x (52.4 ms)	2 ¹⁹ × 1/f _x (104.9 ms)	2 ² × 1/f _x (800 ns)	2 ³ × 1/f _x (1.6 μs)
2 × watch timer output cycle		2 ¹⁶ × watch timer output cycle		Watch timer output edge cycle	

- Remarks**
1. f_x: Main system clock oscillation frequency
 2. MCS: Oscillation mode selection register bit 0
 3. Values in parentheses when operated at f_x = 5.0 MHz

(6) One-shot pulse output

TM0 is able to output one-shot pulse which can set any width of output pulse.

8.2 16-Bit Timer/Event Counter Configuration

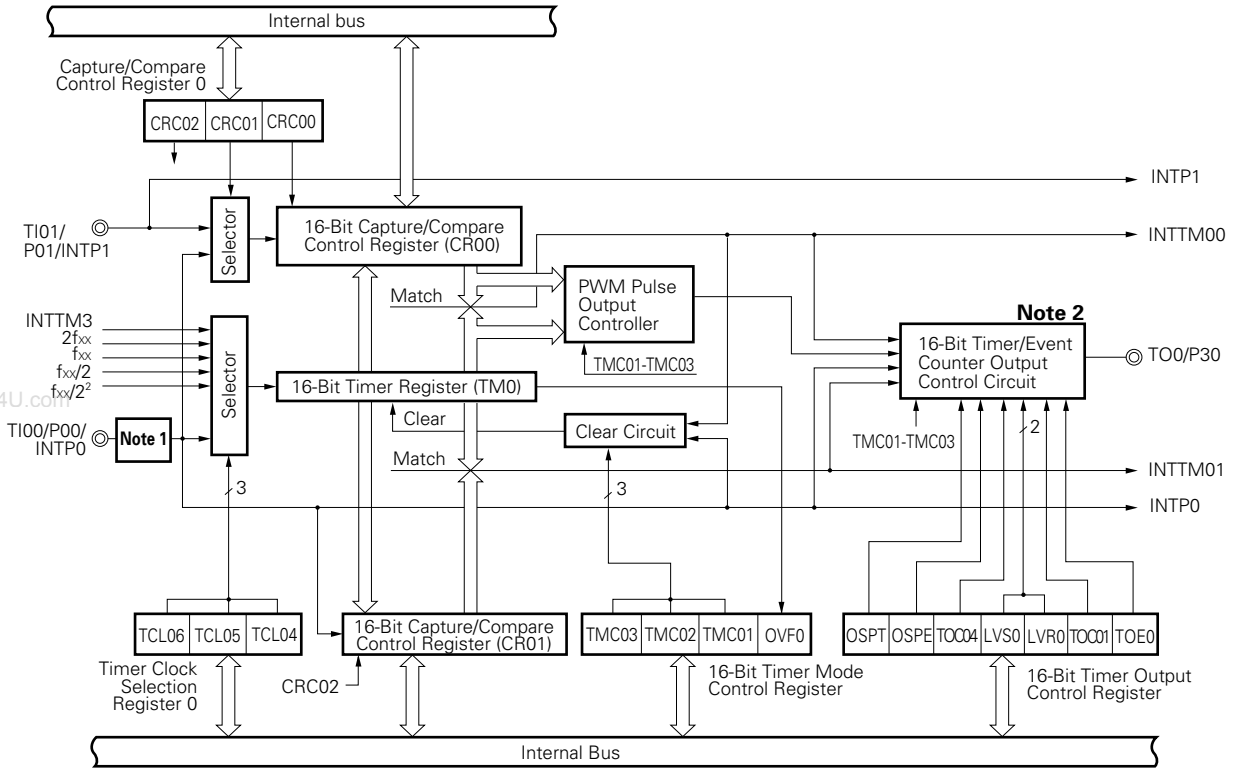
The 16-bit timer/event counter consists of the following hardware.

Table 8-4. 16-Bit Timer/Event Counter Configuration

Item	Configuration
Timer register	16 bits × 1 (TM0)
Register	Capture/compare register: 16 bits × 2 (CR00, CR01)
Timer output	1 (TO0)
Control register	Timer clock select register 0 (TCL0) 16-bit timer mode control register (TMC0) Capture/compare control register 0 (CRC0) 16-bit timer output control register (TOC0) Port mode register 3 (PM3) External interrupt mode register 0 (INTM0) Sampling clock select register (SCS)

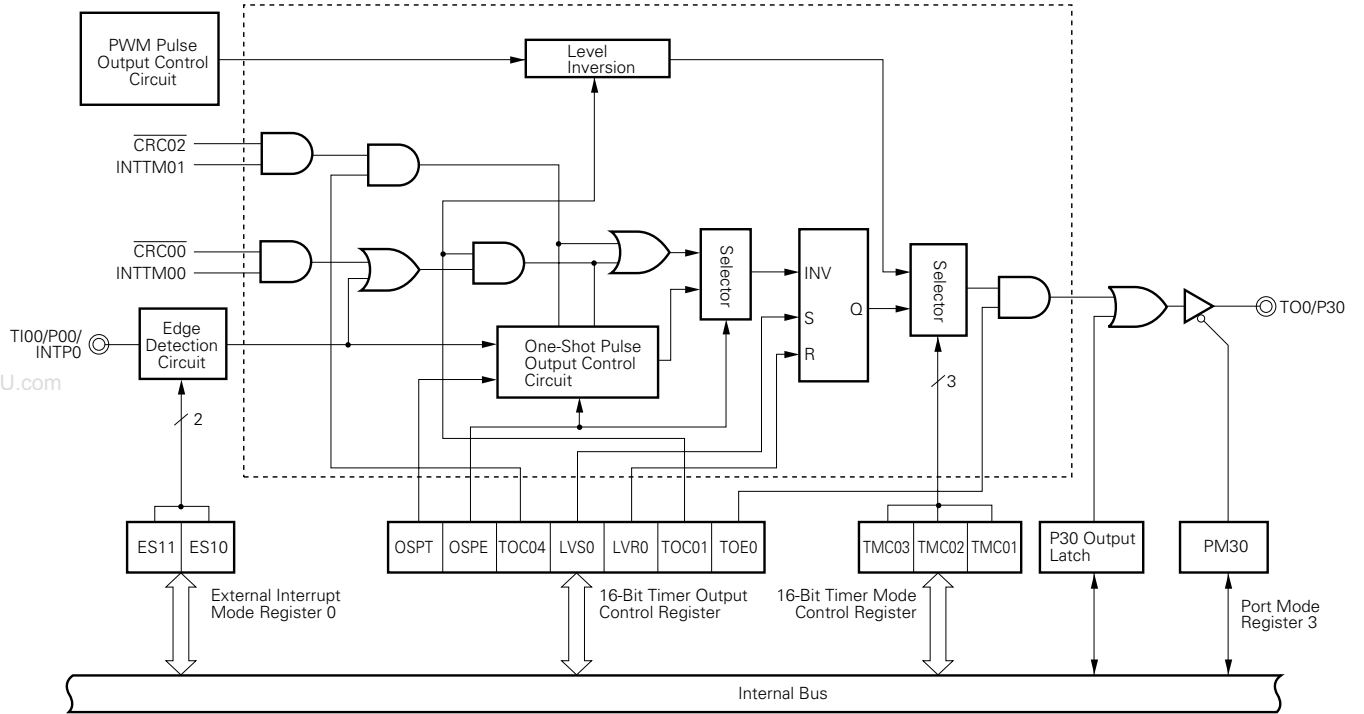
www.DataSheet4U.com

Figure 8-1. 16-Bit Timer/Event Counter Block Diagram



- Notes**
1. Edge detection circuit
 2. The configuration of the 16-bit timer/event counter output control circuit is shown in Figure 8-2.

Figure 8-2. 16-Bit Timer/Event Counter Output Control Circuit Block Diagram



Remark The circuitry enclosed by the dotted line is the output control circuit.

(1) Capture/compare register 00 (CR00)

CR00 is a 16-bit register which has the functions of both a capture register and a compare register. Whether it is used as a capture register or as a compare register is set by bit 0 (CRC00) of capture/compare control register 0.

When CR00 is used as a compare register, the value set in the CR00 is constantly compared with the 16-bit timer register (TM0) count value, and an interrupt request (INTTM00) is generated if they match. It can also be used as the register which holds the interval time when TM0 is set to interval timer operation, and as the register which sets the pulse width in the PWM operating mode.

When CR00 is used as a capture register, it is possible to select the valid edge of the INTP0/TI00 pin or the INTP1/TI01 pin as the capture trigger. Setting of the INTP0/TI00 or INTP1/TI01 valid edge is performed by means of external interrupt mode register 0.

If CR00 is specified as a capture register and capture trigger is specified to be the valid edge of the INTP0/TI00 pin, the situation is as shown in the following table.

Table 8-5. INTP0/TI00 Pin Valid Edge and CR00 Capture Trigger Valid Edge

ES11	ES10	INTP0/TI00 Pin Valid Edge	CR00 Capture Trigger Valid Edge
0	0	Falling edge	Rising edge
0	1	Rising edge	Falling edge
1	0	Setting prohibited	
1	1	Both rising and falling edges	No capture operation

CR00 is set by a 16-bit memory manipulation instruction.

After $\overline{\text{RESET}}$ input, the value of CR00 is undefined.

(2) Capture/compare register 01 (CR01)

CR01 is a 16-bit register which has the functions of both a capture register and a compare register. Whether it is used as a capture register or a compare register is set by bit 2 (CRC02) of capture/compare control register 0.

When CR01 is used as a compare register, the value set in the CR01 is constantly compared with the 16-bit timer register (TM0) count value, and an interrupt request (INTTM01) is generated if they match.

When CR01 is used as a capture register, it is possible to select the valid edge of the INTP0/TI00 pin as the capture trigger. Setting of the INTP0/TI00 valid edge is performed by means of external interrupt mode register 0.

CR01 is set with a 16-bit memory manipulation instruction.

After $\overline{\text{RESET}}$ input, the value of CR01 is undefined.

(3) 16-bit timer register (TM0)

TM0 is a 16-bit register which counts the count pulses.

TM0 is read by a 16-bit memory manipulation instruction. When TM0 is read, capture/compare register (CR01) should first be set as a capture register.

$\overline{\text{RESET}}$ input sets TM0 to 0000H.

Caution As reading of the value of TM0 is performed via CR01, the previously set value of CR01 is lost.

8.3 16-Bit Timer/Event Counter Control Registers

The following seven types of registers are used to control the 16-bit timer/event counter.

- Timer clock select register 0 (TCL0)
- 16-bit timer mode control register (TMC0)
- Capture/compare control register 0 (CRC0)
- 16-bit timer output control register (TOC0)
- Port mode register 3 (PM3)
- External interrupt mode register 0 (INTM0)
- Sampling clock select register (SCS)

www.DataSheet4U.com

(1) Timer clock select register 0 (TCL0)

This register is used to set the count clock of the 16-bit timer register.

TCL0 is set with a 1-bit or 8-bit memory manipulation instruction.

$\overline{\text{RESET}}$ input sets TCL0 value to 00H.

Remark TCL0 has the function of setting the PCL output clock in addition to that of setting the count clock of the 16-bit timer register.

- Cautions**
1. **Setting of the TI00/INTP0 pin valid edge is performed by external interrupt mode register 0, and selection of the sampling clock frequency is performed by the sampling clock selection register.**
 2. **When enabling PCL output, set TCL00 to TCL03, then set 1 in CLOE with a 1-bit memory manipulation instruction.**
 3. **To read the count value when TI00 has been specified as the TM0 count clock, the value should be read from TM0, not from capture/compare register 01 (CR01).**
 4. **When rewriting TCL0 to other data, stop the timer operation beforehand.**

Figure 8-3. Timer Clock Selection Register 0 Format

Symbol	⑦	6	5	4	3	2	1	0	Address	After Reset	R/W
TCL0	CLOE	TCL06	TCL05	TCL04	TCL03	TCL02	TCL01	TCL00	FF40H	00H	R/W

				PCL Output Clock Selection			
TCL03	TCL02	TCL01	TCL00	MCS=1		MCS=0	
0	0	0	0	f _{XT} (32.768 kHz)			
0	1	0	1	f _{XX}	f _X (5.0 MHz)	f _X /2	(2.5 MHz)
0	1	1	0	f _{XX} /2	f _X /2 (2.5 MHz)	f _X /2 ²	(1.25 MHz)
0	1	1	1	f _{XX} /2 ²	f _X /2 ² (1.25 MHz)	f _X /2 ³	(625 kHz)
1	0	0	0	f _{XX} /2 ³	f _X /2 ³ (625 kHz)	f _X /2 ⁴	(313 kHz)
1	0	0	1	f _{XX} /2 ⁴	f _X /2 ⁴ (313 kHz)	f _X /2 ⁵	(156 kHz)
1	0	1	0	f _{XX} /2 ⁵	f _X /2 ⁵ (156 kHz)	f _X /2 ⁶	(78.1 kHz)
1	0	1	1	f _{XX} /2 ⁶	f _X /2 ⁶ (78.1 kHz)	f _X /2 ⁷	(39.1 kHz)
1	1	0	0	f _{XX} /2 ⁷	f _X /2 ⁷ (39.1 kHz)	f _X /2 ⁸	(19.5 kHz)
Other than above				Setting prohibited			

			16-Bit Timer Register Count Clock Selection			
TCL06	TCL05	TCL04	MCS=1		MCS=0	
0	0	0	TI00 (Valid edge specifiable)			
0	0	1	2f _{XX}	Setting prohibited		f _X (5.0 MHz)
0	1	0	f _{XX}	f _X (5.0 MHz)	f _X /2	(2.5 MHz)
0	1	1	f _{XX} /2	f _X /2 (2.5 MHz)	f _X /2 ²	(1.25 MHz)
1	0	0	f _{XX} /2 ²	f _X /2 ² (1.25 MHz)	f _X /2 ³	(625 kHz)
1	1	1	Watch timer output (INTTM 3)			
Other than above			Setting prohibited			

CLOE	PCL Output Control
0	Output disabled
1	Output enabled

- Remarks**
1. f_{XX} : Main system clock frequency (f_X or f_X/2)
 2. f_X : Main system clock oscillation frequency
 3. f_{XT} : Subsystem clock oscillation frequency
 4. TI00 : 16-bit timer/event counter input pin
 5. TM0 : 16-bit timer register
 6. MCS : Bit 0 of oscillation mode selection register
 7. Figures in parentheses apply to operation with f_X = 5.0 MHz of f_{XT} = 32.768 kHz.

(2) 16-bit timer mode control register (TMC0)

This register sets the 16-bit timer operating mode, the 16-bit timer register clear mode and output timing, and detects an overflow.

TMC0 is set with a 1-bit or 8-bit memory manipulation instruction.

RESET input sets TMC0 value to 00H.

Caution The 16-bit timer register starts operation at the moment a value other than 0, 0, 0 (operation stop mode) is set in TMC01 to TMC03, respectively. Set 0, 0, 0 in TMC01 to TMC03 to stop the operation.

Figure 8-4. 16-Bit Timer Mode Control Register Format

Symbol	7	6	5	4	3	2	1	①	Address	After Reset	R/W
TMC0	0	0	0	0	TMC03	TMC02	TMC01	OVF0	FF48H	00H	R/W

OVF0	16-Bit Timer Register Overflow Detection
0	Overflow not detected
1	Overflow detected

TMC03	TMC02	TMC01	Operating Mode Clear Mode Selection	T00 Output Timing Selection	Interrupt Generation
0	0	0	Operation stop (TM0 cleared to 0)	No change	Not Generated
0	0	1	PWM mode (free running)	PWM pulse output	Generated on match between TM0 and CR00, and match between TM0 and CR01
0	1	0	Free running mode	Match between TM0 and CR00 or match between TM0 and CR01	
0	1	1		Match between TM0 and CR00, match between TM0 and CR01 or TI00 valid edge	
1	0	0	Clear & start on TI00 valid edge	Match between TM0 and CR00 or match between TM0 and CR01	
1	0	1		Match between TM0 and CR00, match between TM0 and CR01 or TI00 valid edge	
1	1	0	Clear & start on match between TM0 and CR00	Match between TM0 and CR00 or match between TM0 and CR01	
1	1	1		Match between TM0 and CR00, match between TM0 and CR01 or TI00 valid edge	

Remark TO0 : 16-bit timer/event counter output pin
 TI00 : 16-bit timer/event counter input pin
 TM0 : 16-bit timer register
 CR00 : Compare register 00
 CR01 : Compare register 01

- Cautions**
1. Switch the clear mode and the T00 output timing after stopping the timer operation (by setting TMC01 to TMC03 to 0, 0, 0).
 2. Set the valid edge of the TI00/INTP0 pin with an external interrupt mode register 0 and select the sampling clock frequency with a sampling clock select register.
 3. When using the PWM mode, set the PWM mode and then set data to CR00.
 4. If clear & start mode on match between TM0 and CR00 is selected, when the set value of CR00 is FFFFH and the TM0 value changes from FFFFH to 0000H, OVF0 flag is set to 1.

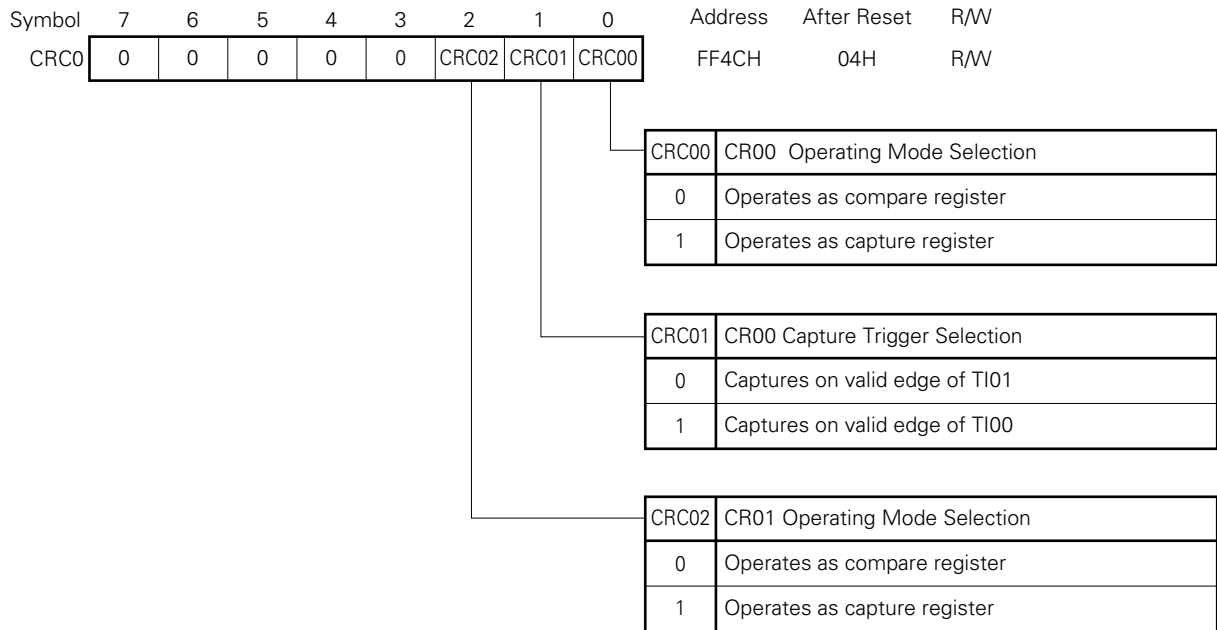
(3) Capture/compare control register 0 (CRC0)

This register controls the operation of the capture/compare registers (CR00, CR01).

CRC0 is set with a 1-bit or 8-bit memory manipulation instruction.

RESET input sets CRC0 value to 04H.

Figure 8-5. Capture/Compare Control Register 0 Format



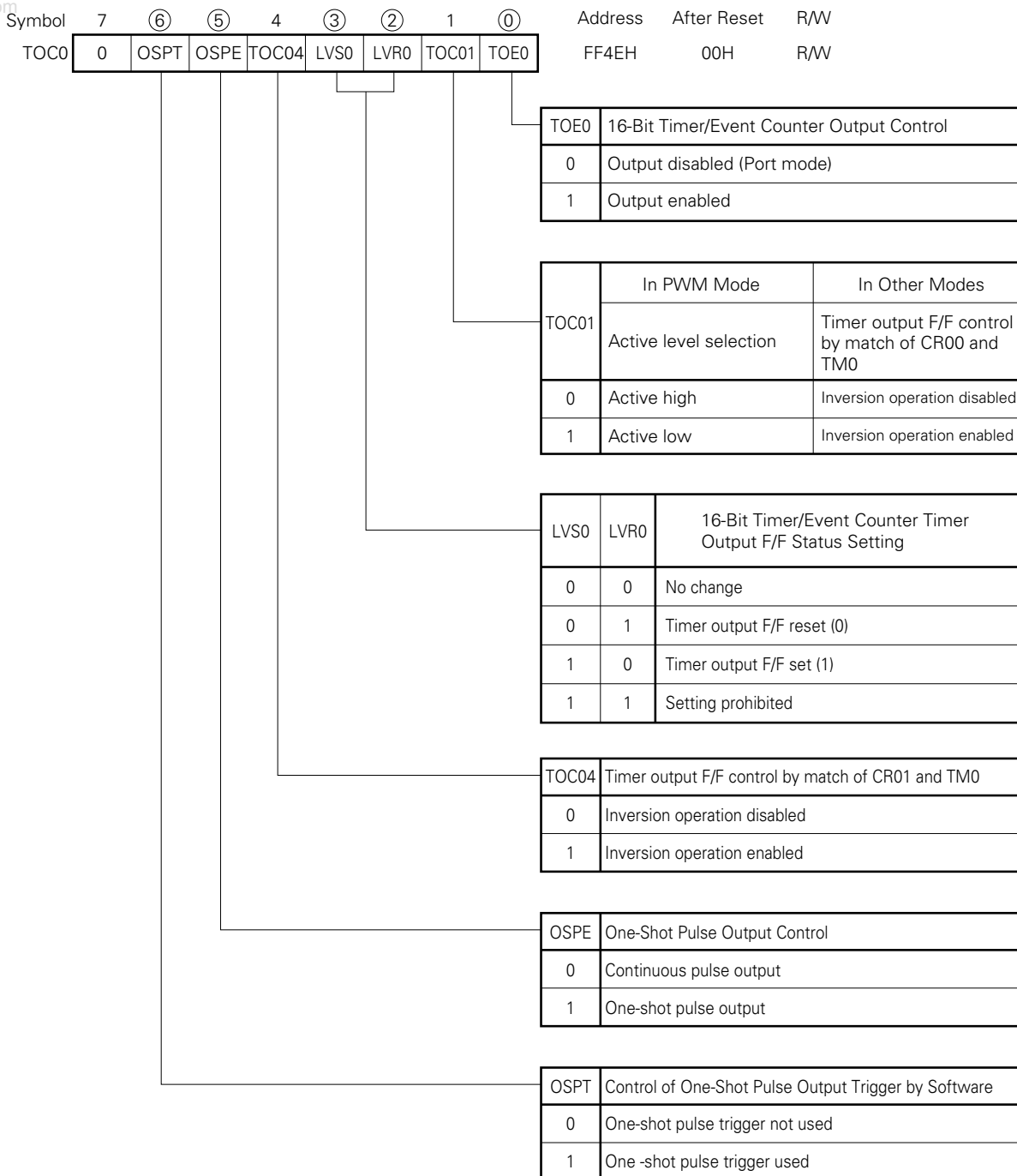
- Cautions**
1. Timer operation must be stopped before setting CRC0.
 2. When clear & start mode on a match between TM0 and CR00 is selected with the 16-bit timer mode control register, CR00 should not be specified as a capture register.

(4) 16-bit timer output control register (TOC0)

This register controls the operation of the 16-bit timer/event counter output control circuit. It sets R-S type flip-flop (LV0) setting/resetting, the active level in PWM mode, inversion enabling/disabling in modes other than PWM mode, 16-bit timer/event counter timer output enabling/disabling, one-shot pulse output operation enabling/disabling, and output trigger for a one-shop pulse by software. TOC0 is set with a 1-bit or 8-bit memory manipulation instruction. RESET input sets TOC0 value to 00H.

- Cautions**
1. **Timer operation must be stopped before setting TOC0.**
 2. **If LVS0 and LVR0 are read after data is set, they will be 0.**
 3. **OSPT is cleared automatically after data setting, and will therefore be 0 if read.**

Figure 8-6. 16-Bit Timer Output Control Register Format



(5) Port mode register 3 (PM3)

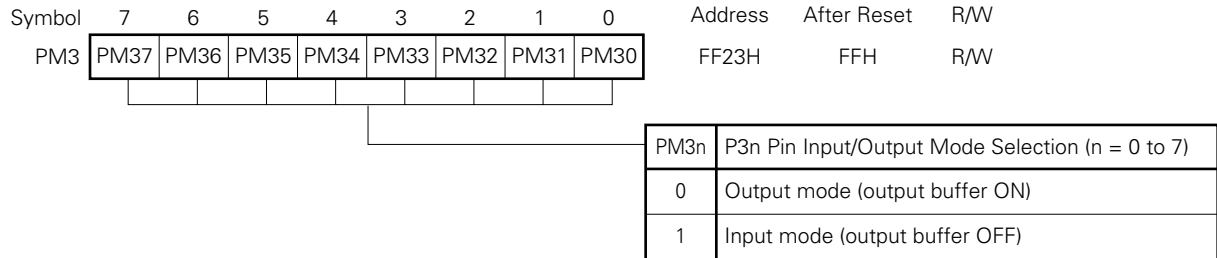
This register sets port 3 input/output in 1-bit units.

When using the P30/TO0 pin for timer output, set PM30 and output latch of P30 to 0.

PM3 is set with a 1-bit or 8-bit memory manipulation instruction.

RESET input sets PM3 value to FFH.

Figure 8-7. Port Mode Register 3 Format



www.DataSheet4U.com

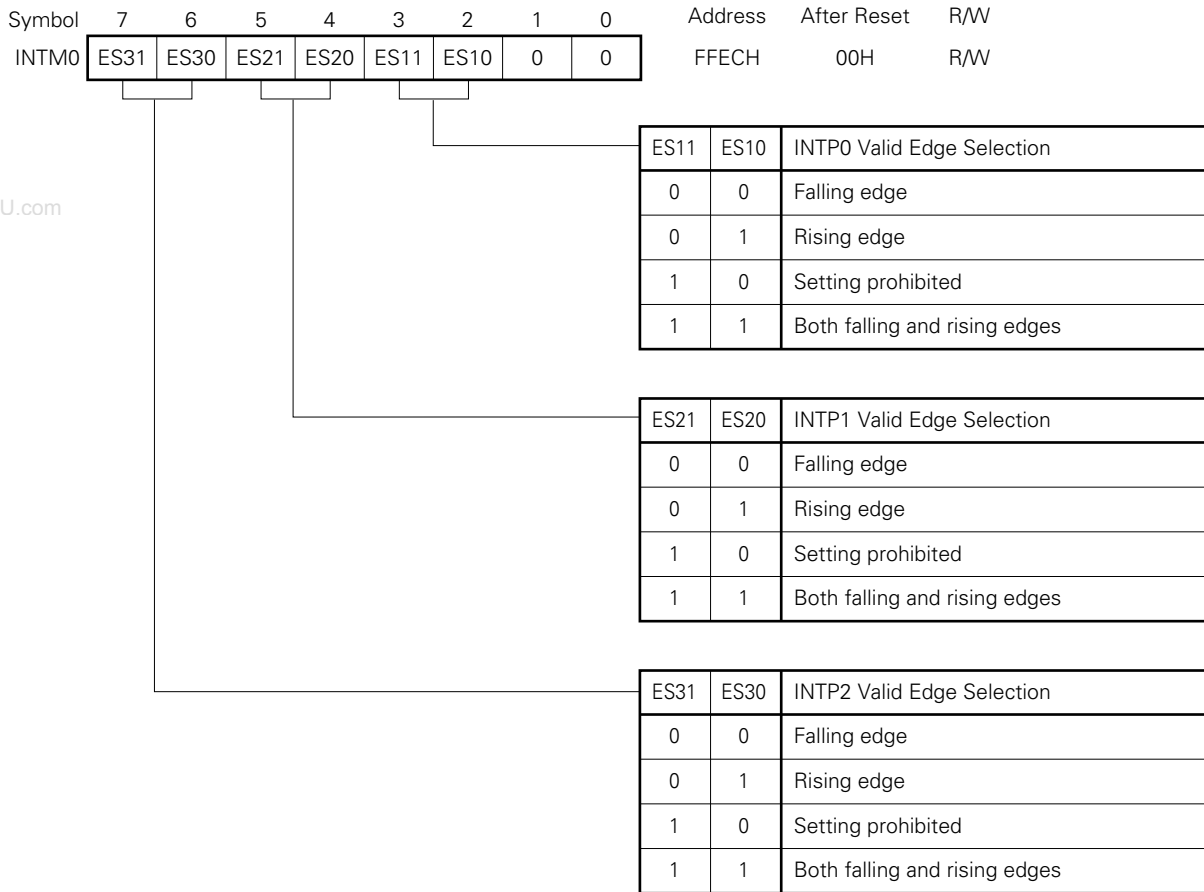
(6) External interrupt mode register 0 (INTM0)

This register is used to set INTP0 to INTP2 valid edges.

INTM0 is set with an 8-bit memory manipulation instruction.

$\overline{\text{RESET}}$ input sets INTM0 value to 00H.

Figure 8-8. External Interrupt Mode Register 0 Format



www.DataSheet4U.com

(7) Sampling clock select registers (SCS)

This register sets clocks which undergo clock sampling of valid edges to be input to INTPO. When remote controlled reception is carried out using INTPO, digital noise is removed with sampling clock.

SCS is set with an 8-bit memory manipulation instruction.

RESET input sets SCS value to 00H.

Figure 8-9. Sampling Clock Select Register Format



Caution $f_{xx}/2^N$ is the clock supplied to the CPU, and $f_{xx}/2^5$, $f_{xx}/2^6$, and $f_{xx}/2^7$ are clocks supplied to peripheral hardware. $f_{xx}/2^N$ is stopped in HALT mode.

- Remarks**
1. N : Value set in bit 0 to bit 2 (PCC0 to PCC2) of the processor clock control register (N = 0 to 4)
 2. f_{xx} : Main system clock frequency (fx or fx/2)
 3. f_x : Main system clock oscillation frequency
 4. MCS : Bit 0 of oscillation mode selection register
 5. Figures in parentheses apply to operation with $f_x = 5.0$ MHz.

8.4 16-Bit Timer/Event Counter Operations

8.4.1 Interval timer operations

Setting the 16-bit timer mode control register (TMC0) and capture/compare control register 0 (CRC0) as shown in Figure 8-10 allows operation as an interval timer. Interrupts are generated repeatedly using the count value set in 16-bit capture/compare register 00 (CR00) beforehand as the interval.

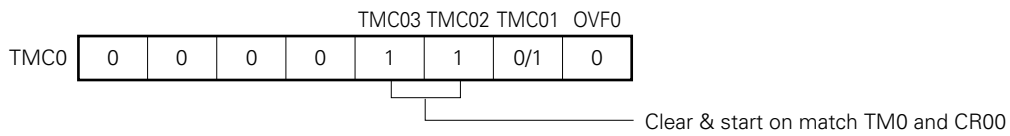
When the count value of the 16-bit timer register (TM0) matches the value set to CR00, counting continues with the TM0 value cleared to 0 and the interrupt request signal (INTTM00) is generated.

Count clock of the 16-bit timer/event counter can be selected with bit 4 to bit 6 (TCL04 to TCL06) of the timer clock select register 0 (TCL0).

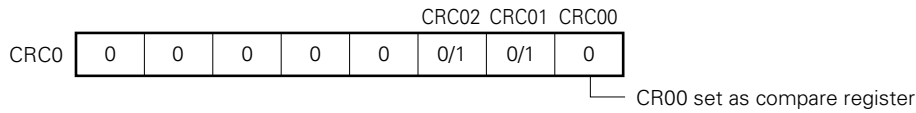
Figure 8-10. Control Register Settings for Interval Timer Operation

www.DataSheet4U.com

(a) 16-bit timer mode control register (TMC0)

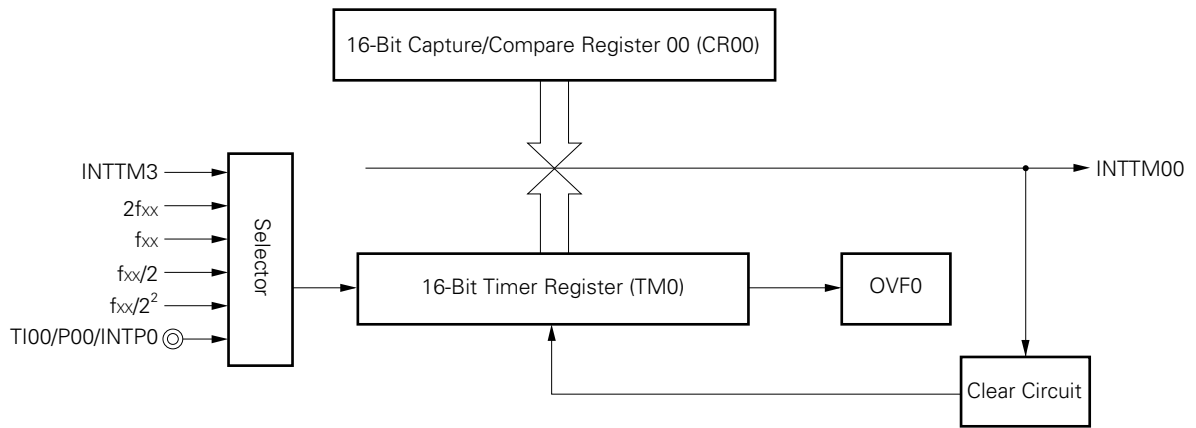


(b) Capture/compare control register 0 (CRC0)



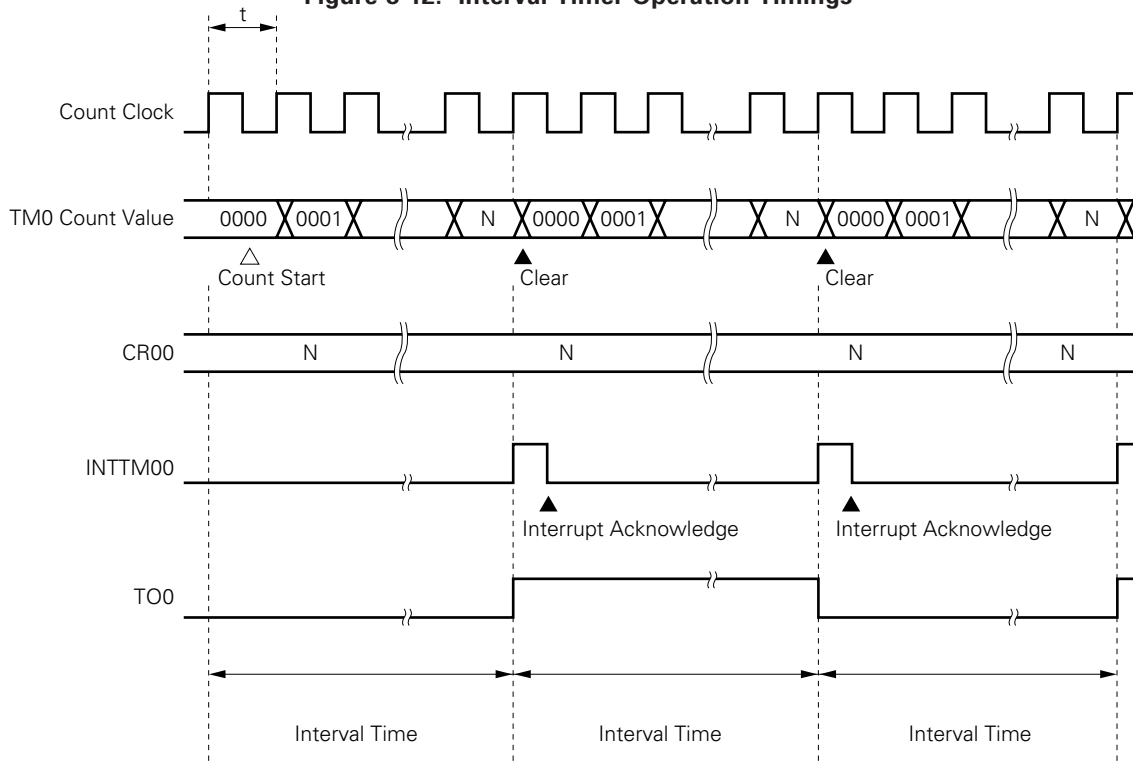
Remark 0/1 : Setting 0 or 1 allows another function to be used simultaneously with the interval timer. See the description of the respective control registers for details.

Figure 8-11. Interval Timer Configuration Diagram



www.DataSheet4U.com

Figure 8-12. Interval Timer Operation Timings



Remark Interval time = $(N + 1) \times t$: $N = 0001H$ to $FFFFH$.

Table 8-6. 16-Bit Timer/Event Counter Interval Times

TCL06	TCL05	TCL04	Minimum Interval Time		Maximum Interval Time		Resolution	
			MCS = 1	MCS = 0	MCS = 1	MCS = 0	MCS = 1	MCS = 0
0	0	0	2 × TI00 input cycle		2 ¹⁶ × TI00 input cycle		TI00 input edge cycle	
0	0	1	Setting prohibited	2 × 1/f _x (400 ns)	Setting prohibited	2 ¹⁶ × 1/f _x (13.1 ms)	Setting prohibited	1/f _x (200 ns)
0	1	0	2 × 1/f _x (400 ns)	2 ² × 1/f _x (800 ns)	2 ¹⁶ × 1/f _x (13.1 ms)	2 ¹⁷ × 1/f _x (26.2 ms)	1/f _x (200 ns)	2 × 1/f _x (400 ns)
0	1	1	2 ² × 1/f _x (800 ns)	2 ³ × 1/f _x (1.6 μs)	2 ¹⁷ × 1/f _x (26.2 ms)	2 ¹⁸ × 1/f _x (52.4 ms)	2 × 1/f _x (400 ns)	2 ² × 1/f _x (800 ns)
1	0	0	2 ³ × 1/f _x (1.6 μs)	2 ⁴ × 1/f _x (3.2 μs)	2 ¹⁸ × 1/f _x (52.4 ms)	2 ¹⁹ × 1/f _x (104.9 ms)	2 ² × 1/f _x (800 ns)	2 ³ × 1/f _x (1.6 μs)
1	1	1	2 × watch timer output cycle		2 ¹⁶ × watch timer output cycle		Watch timer output edge cycle	
Other than above			Setting prohibited					

- Remarks**
1. f_x : Main system clock oscillation frequency
 2. MCS : Bit 0 of oscillation mode selection register
 3. Figures in parentheses apply to operation with f_x = 5.0 MHz

8.4.2 PWM output operations

Setting the 16-bit timer mode control register (TMC0), capture/compare control register 0 (CRC0), and the 16-bit timer output control register (TOC0) as shown in Figure 8-13 allows operation as PWM output. Pulses with the duty rate determined by the value set in 16-bit capture/compare register 00 (CR00) beforehand are output from the TO0/P30 pin.

Set the active level width of the PWM pulse to the high-order 14 bits of CR00. Select the active level with bit 1 (TOC01) of the 16-bit timer output control register (TOC0).

This PWM pulse has a 14-bit resolution. The pulse can be converted to an analog voltage by integrating it with an external low-pass filter (LPF). The PWM pulse is formed by a combination of the basic cycle determined by 2⁸/Φ and the sub-cycle determined by 2¹⁴/Φ so that the time constant of the external LPF can be shortened. Count clock Φ can be selected with bit 4 to bit 6 (TCL04 to TCL06) of the timer clock select register 0 (TCL0).

PWM output enable/disable can be selected with bit 0 (TOE0) of TOC0.

- Cautions**
1. PWM operation mode should be selected before setting CR00.
 2. Be sure to write 0 to bits 0 and 1 of CR00.
 3. Do not select PWM operation mode for external clock input from the TI00/P00 pin.

By integrating 14-bit resolution PWM pulses with an external low-pass filter, they can be converted to an analog voltage and used for electronic tuning and D/A converter applications, etc.

The analog output voltage (V_{AN}) used for D/A conversion with the configuration shown in Figure 8-14 is as follows.

$$V_{AN} = V_{REF} \times \frac{\text{capture/compare register 00 (CR00) value}}{2^{16}}$$

V_{REF} : External switching circuit reference voltage

Figure 8-14. Example of D/A Converter Configuration with PWM Output

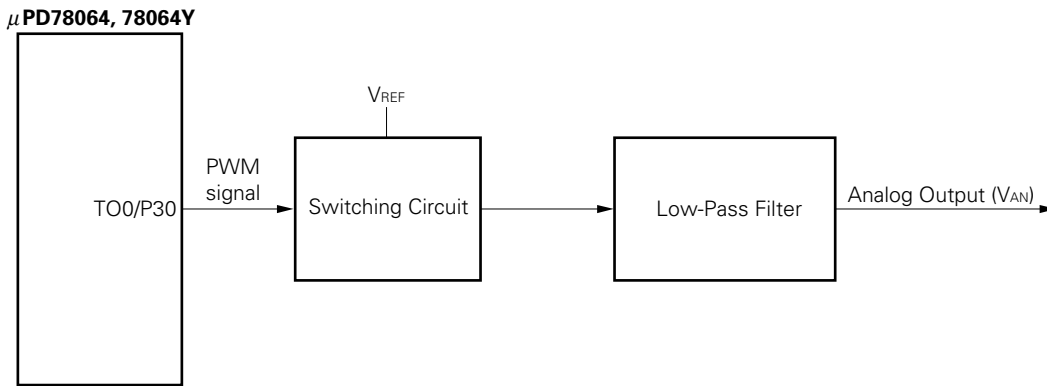
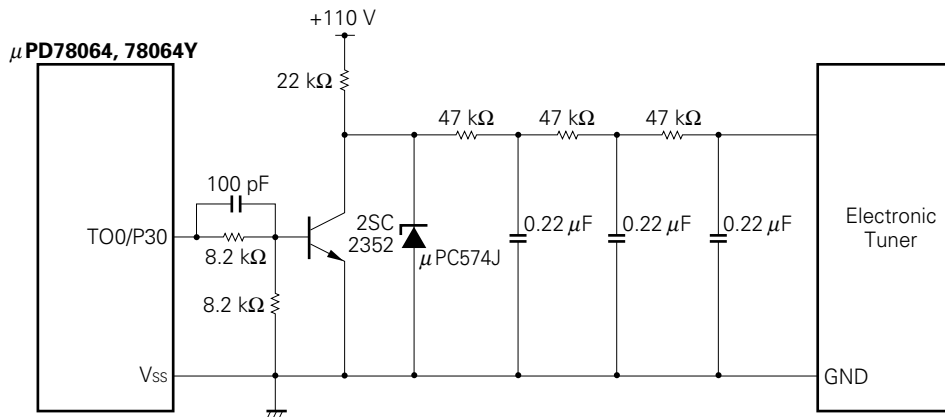


Figure 8-15 shows an example in which PWM output is converted to an analog voltage and used in a voltage synthesizer type TV tuner.

Figure 8-15. TV Tuner Application Circuit Example



8.4.4 Pulse width measurement operations

It is possible to measure the pulse width of the signals input to the TI00/P00 pin and TI01/P01 pin using the 16-bit timer register (TM0).

There are two measurement methods: measuring with TM0 used in free-running mode, and measuring by restarting the timer in synchronization with the edge of the signal input to the TI00/P00 pin.

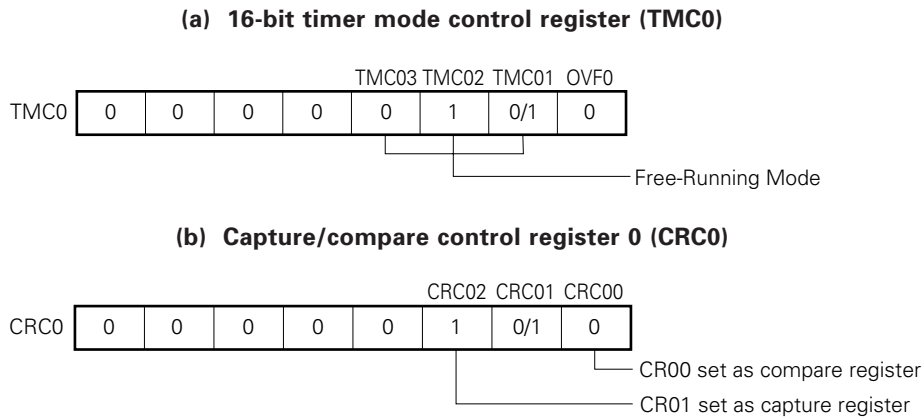
(1) Pulse width measurement with free-running counter and one capture register

When the 16-bit timer register (TM0) is operated in free-running mode (see register settings in Figure 8-17), and the edge specified by external interrupt mode register 0 (INTM0) is input to the TI00/P00 pin, the value of TM0 is taken into 16-bit capture/compare register 01 (CR01) and an external interrupt request signal (INTP0) is set.

Any of three edge specifications can be selected—rising, falling, or both edges—by means of bits 2 and 3 (ES10 and ES11) of INTM0.

For valid edge detection, sampling is performed at the interval selected by means of the sampling clock selection register (SCS), and a capture operation is only performed when a valid level is detected twice, thus eliminating noise with a short pulse width.

Figure 8-17. Control Register Settings for Pulse Width Measurement with Free-Running Counter and One Capture Register



Remark 0/1: Setting 0 or 1 allows another function to be used simultaneously with pulse width measurement. See the description of the respective control registers for details.

Figure 8-18. Configuration Diagram for Pulse Width Measurement by Free-Running Counter

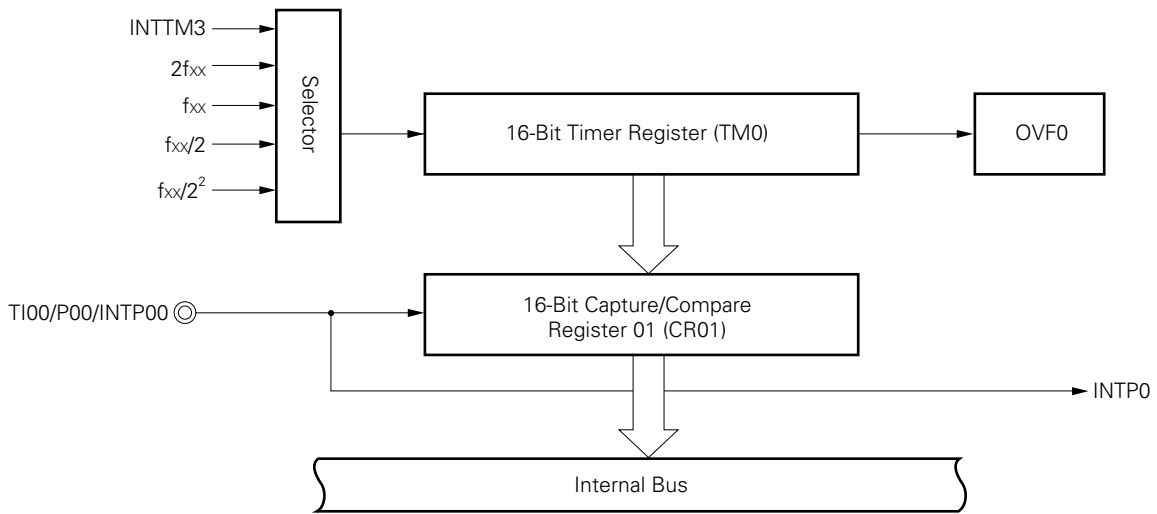
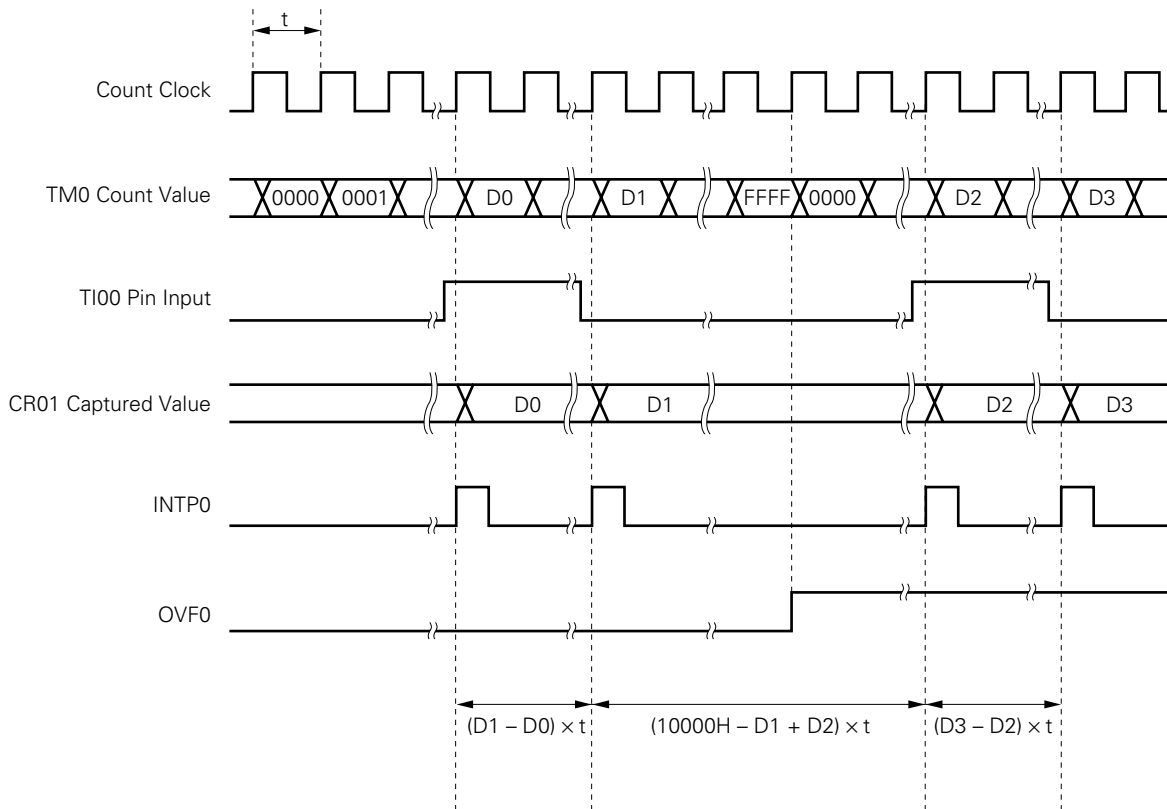


Figure 8-19. Timing of Pulse Width Measurement Operation by Free-Running Counter and One Capture Register (with Both Edges Specified)



(2) Measurement of two pulse widths with free-running counter

When the 16-bit timer register (TM0) is operated in free-running mode (see register settings in Figure 8-20), it is possible to simultaneously measure the pulse widths of the two signals input to the TI00/P00 pin and the TI01/P01 pin.

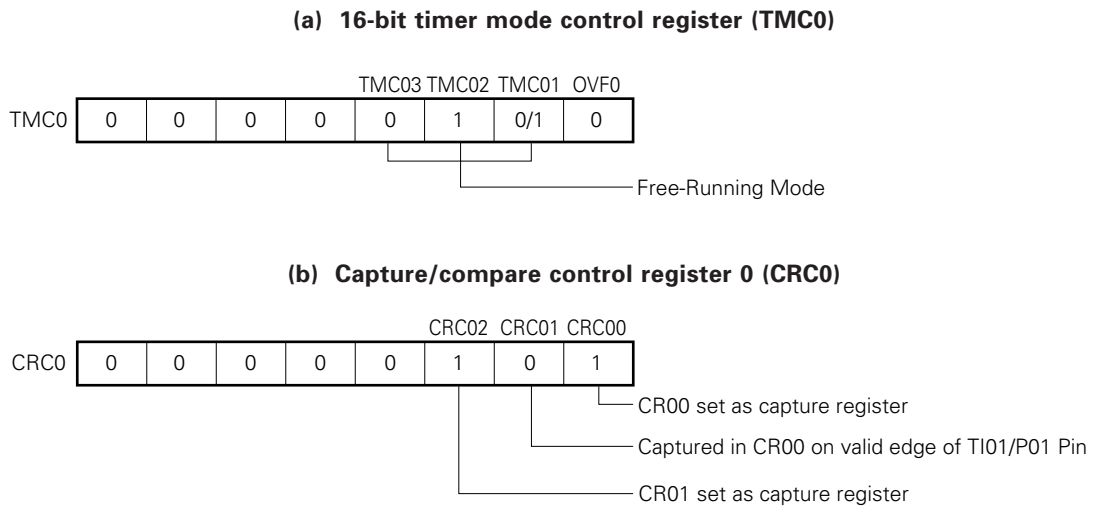
When the edge specified by bits 2 and 3 (ES10 and ES11) of external interrupt mode register 0 (INTM0) is input to the TI00/P00 pin, the value of TM0 is taken into 16-bit capture/compare register 01 (CR01) and an external interrupt request signal (INTP0) is set.

Also, when the edge specified by bits 4 and 5 (ES20 and ES21) of INTM0 is input to the TI01/P01 pin, the value of TM0 is taken into 16-bit capture/compare register 00 (CR00) and an external interrupt request signal (INTP1) is set.

Any of three edge specifications can be selected—rising, falling, or both edges—as the valid edges for the TI00/P00 pin and the TI01/P01 pin by means of bits 2 and 3 (ES10 and ES11) and bits 4 and 5 (ES20 and ES21) of INTM0, respectively.

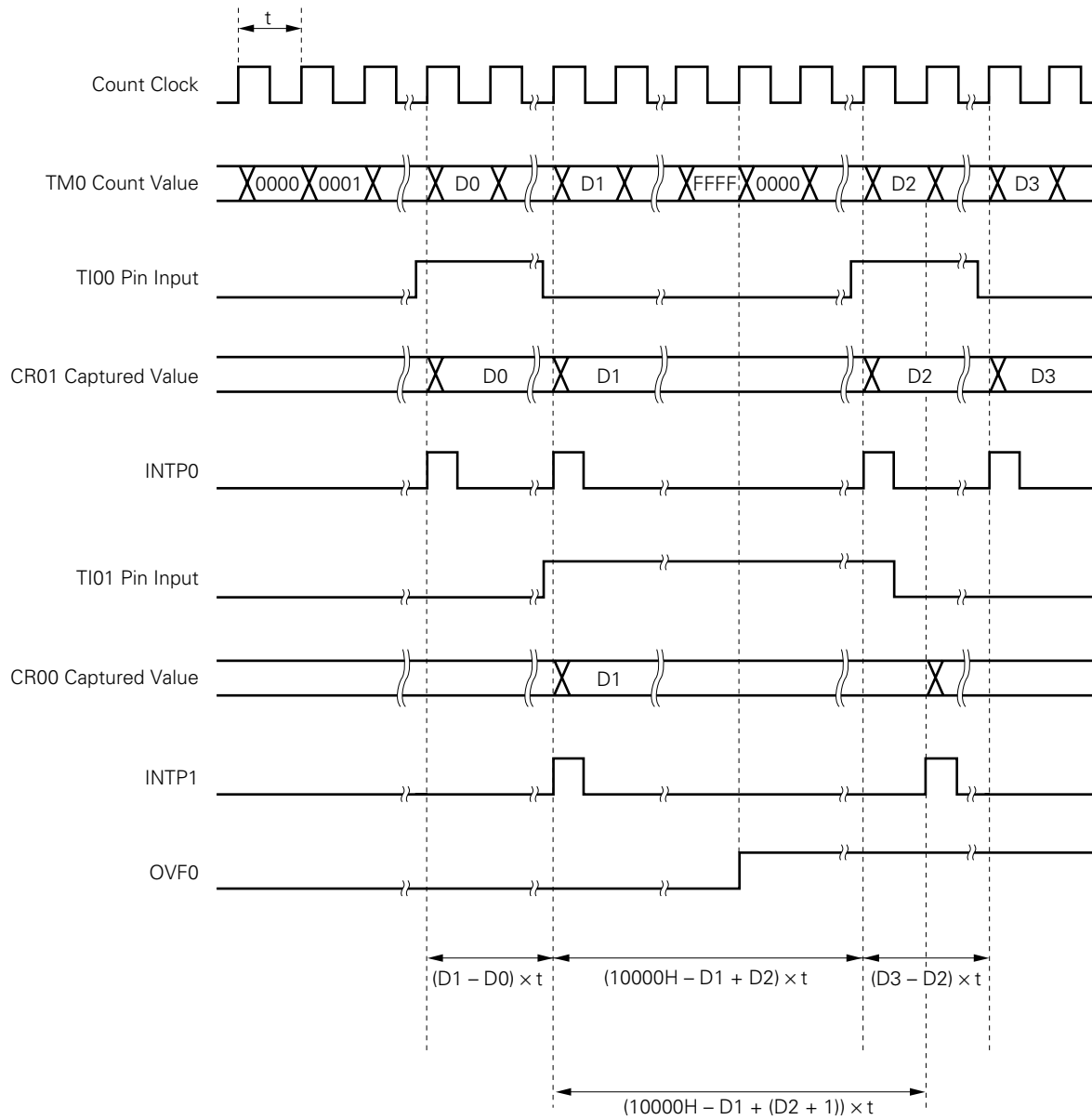
For TI00/P00 pin valid edge detection, sampling is performed at the interval selected by means of the sampling clock selection register (SCS), and a capture operation is only performed when a valid level is detected twice, thus eliminating noise with a short pulse width.

Figure 8-20. Control Register Settings for Two Pulse Width Measurements with Free-Running Counter



Remark 0/1: Setting 0 or 1 allows another function to be used simultaneously with pulse width measurement. See the description of the respective control registers for details.

Figure 8-21. Timing of Pulse Width Measurement Operation with Free-Running Counter (with Both Edges Specified)



www.DataSheet4U.com

(3) Pulse width measurement with free-running counter and two capture registers

When the 16-bit timer register (TM0) is operated in free-running mode (see register settings in Figure 8-22), it is possible to measure the pulse width of the signal input to the TI00/P00 pin.

When the edge specified by bits 2 and 3 (ES10 and ES11) of external interrupt mode register 0 (INTM0) is input to the TI00/P00 pin, the value of TM0 is taken into 16-bit capture/compare register 01 (CR01) and an external interrupt request signal (INTP0) is set.

Also, on the inverse edge input of that of the capture operation into CR01, the value of TM0 is taken into 16-bit capture/compare register 00 (CR00).

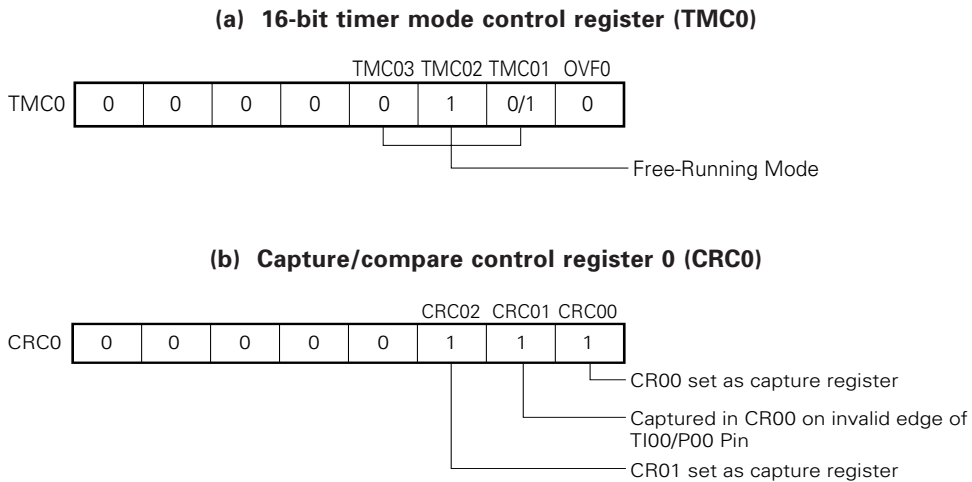
Either of two edge specifications can be selected—rising or falling—as the valid edges for the TI00/P00 pin by means of bits 2 and 3 (ES10 and ES11) of INTM0.

For TI00/P00 pin valid edge detection, sampling is performed at the interval selected by means of the sampling clock selection register (SCS), and a capture operation is only performed when a valid level is detected twice,

thus eliminating noise with a short pulse width.

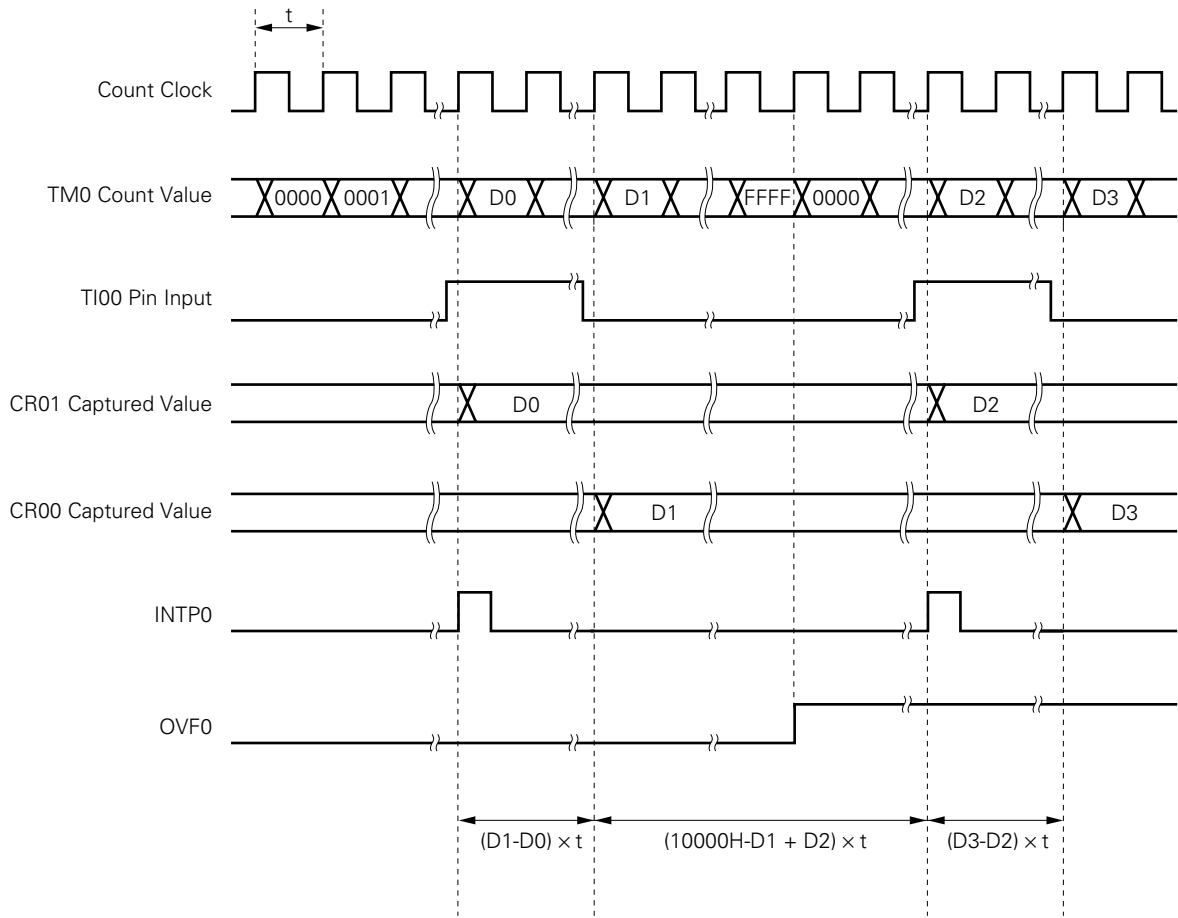
Caution If the valid edge of TI00/P00 is specified to be both rising and falling edge, capture/compare register 00 (CR00) cannot perform the capture operation.

Figure 8-22. Control Register Settings for Pulse Width Measurement with Free-Running Counter and Two Capture Registers



Remark 0/1: Setting 0 or 1 allows another function to be used simultaneously with pulse width measurement. See the description of the respective control registers for details.

Figure 8-23. Timing of Pulse Width Measurement Operation by Free-Running Counter and Two Capture Registers (with Rising Edge Specified)



www.DataSheet4U.com

(4) Pulse width measurement by means of restart

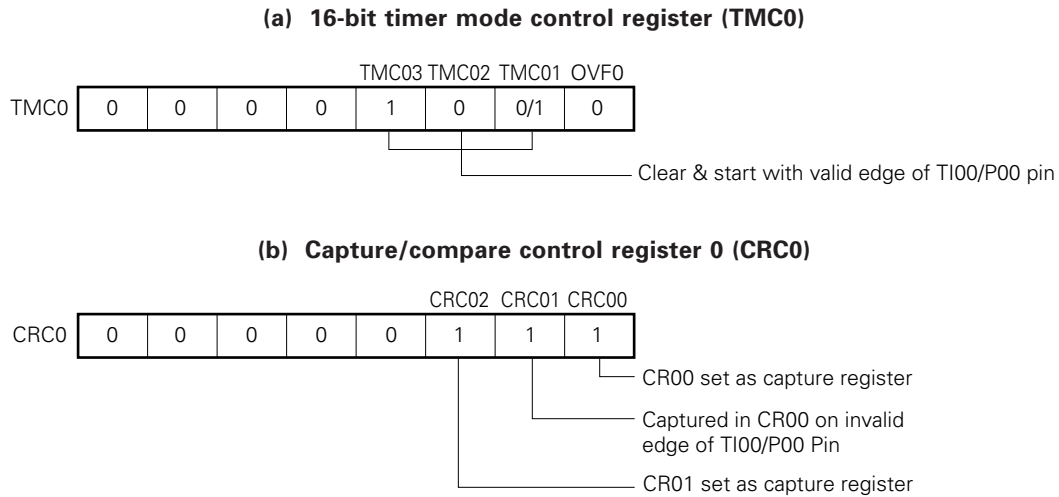
When input of a valid edge to the TI00/P00 pin is detected, the count value of the 16-bit timer register (TM0) is taken into 16-bit capture/compare register 01 (CR01), and then the pulse width of the signal input to the TI00/P00 pin is measured by clearing TM0 and restarting the count (see register settings in Figure 8-24). The edge specification can be selected from two types, rising and falling edges by INTM0 bits 2 and 3 (ES10 and ES11).

In a valid edge detection, the sampling is performed by a cycle selected by the sampling clock selection register (SCS), and a capture operation is only performed when a valid level is detected twice, thus eliminating noise with a short pulse width.

Caution If the valid edge of TI00/P00 is specified to be both rising and falling edge, the 16-bit capture/compare register 00 (CR00) cannot perform the capture operation.

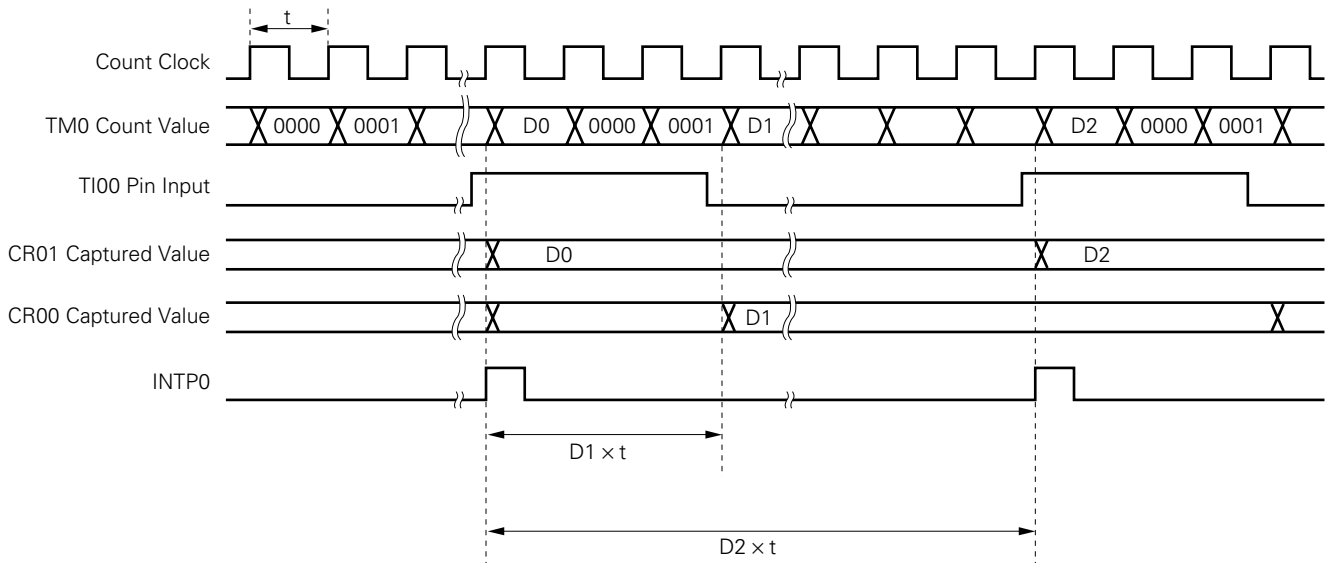
www.DataSheet4U.com

Figure 8-24. Control Register Settings for Pulse Width Measurement by Means of Restart



Remark 0/1: Setting 0 or 1 allows another function to be used simultaneously with pulse width measurement. See the description of the respective control registers for details.

Figure 8-25. Timing of Pulse Width Measurement Operation by Means of Restart (with Rising Edge Specified)



8.4.5 External event counter operation

The external event counter counts the number of external clock pulses to be input to the TI00/P00 pin with the 16-bit timer register (TM0).

TM0 is incremented each time the valid edge specified with the external interrupt mode register 0 (INTM0) is input.

When the TM0 counted value matches the 16-bit capture/compare register 00 (CR00) value, TM0 is cleared to 0 and the interrupt request signal (INTTM00) is generated.

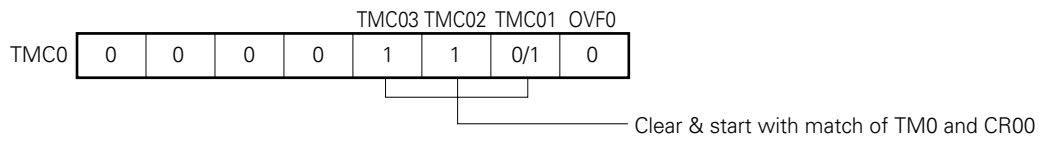
The rising edge, the falling edge or both edges can be selected with bits 2 and 3 (ES10 and ES11) of INTM0.

Because operation is carried out only after the valid edge is detected twice by sampling at the interval selected with the sampling clock select register (SCS), noise with short pulse widths can be removed.

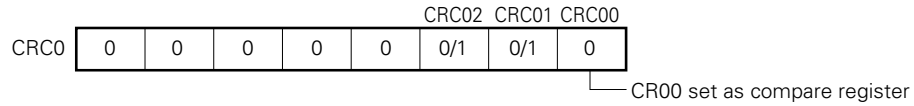
Figure 8-26. Control Register Settings in External Event Counter Mode

www.DataSheet4U.com

(a) 16-bit timer mode control register (TMC0)



(b) Capture/compare control register 0 (CRC0)



Remark 0/1: Setting 0 or 1 allows another function to be used simultaneously with the external event counter. See the description of the respective control registers for details.

Figure 8-27. External Event Counter Configuration Diagram

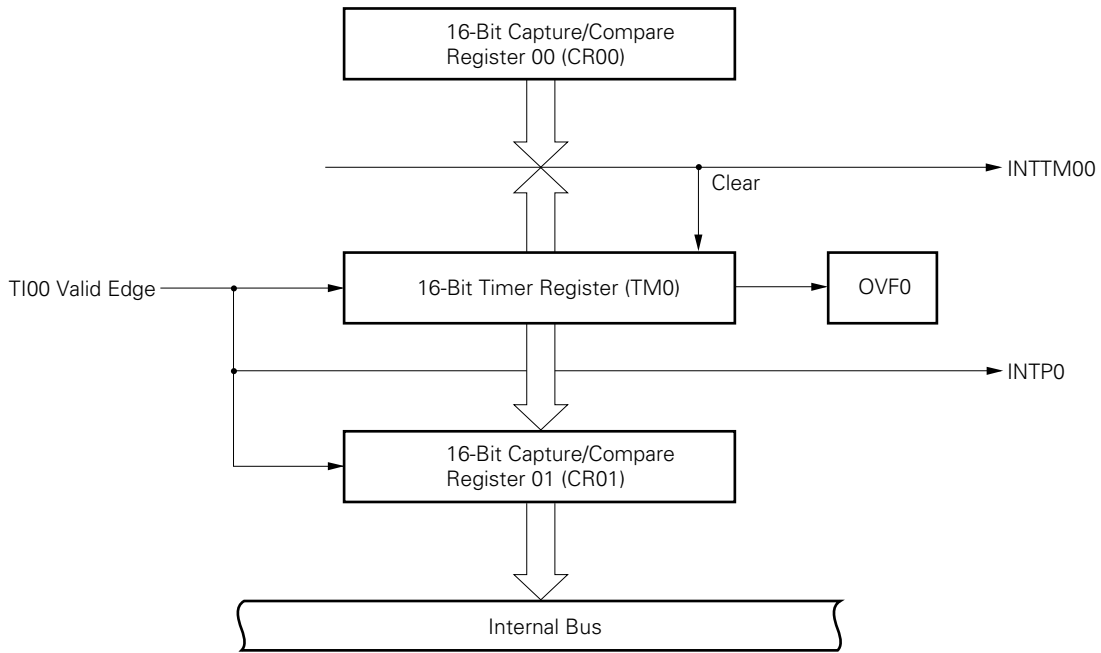
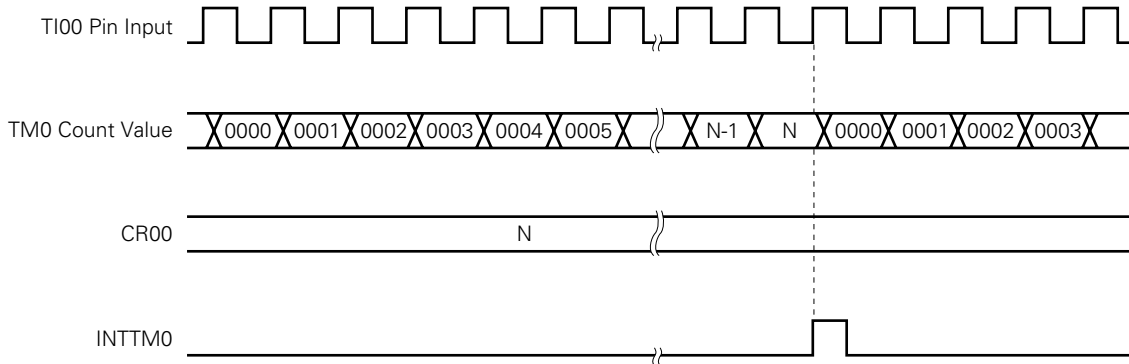


Figure 8-28. External Event Counter Operation Timings (with Rising Edge Specified)



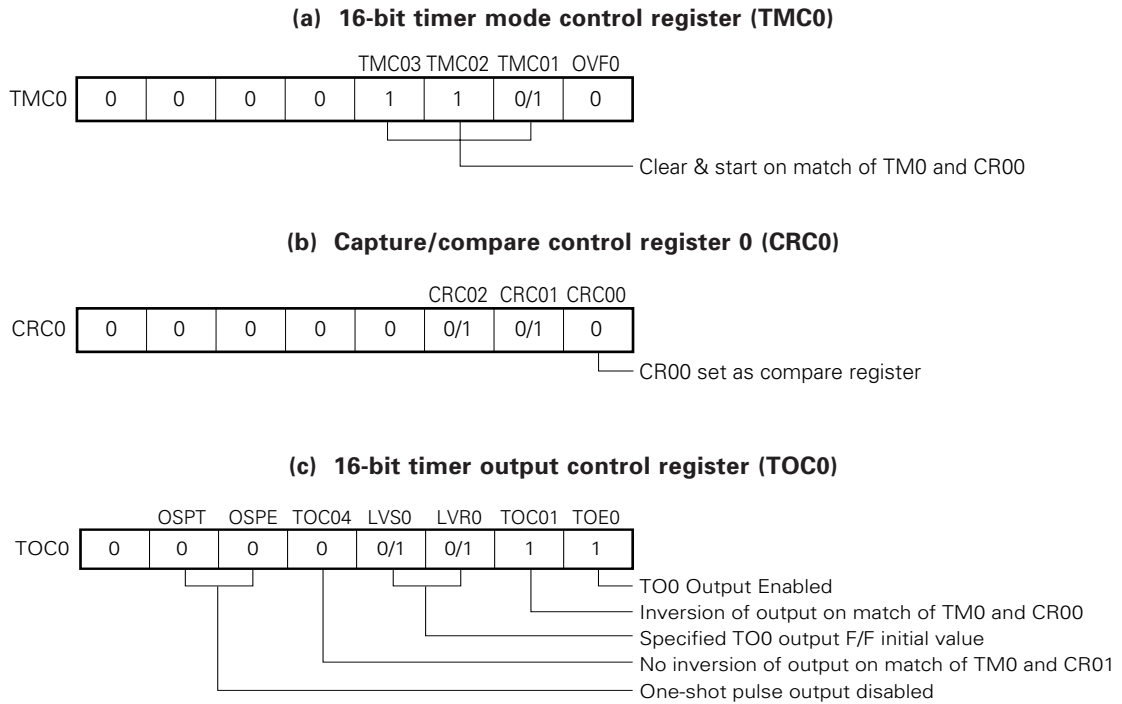
Caution When reading the external event counter count value, TM0 should be read.

8.4.6 Square-wave output operation

A square wave with any selected frequency is output at intervals of the count value preset to the 16-bit capture/compare register 00 (CR00).

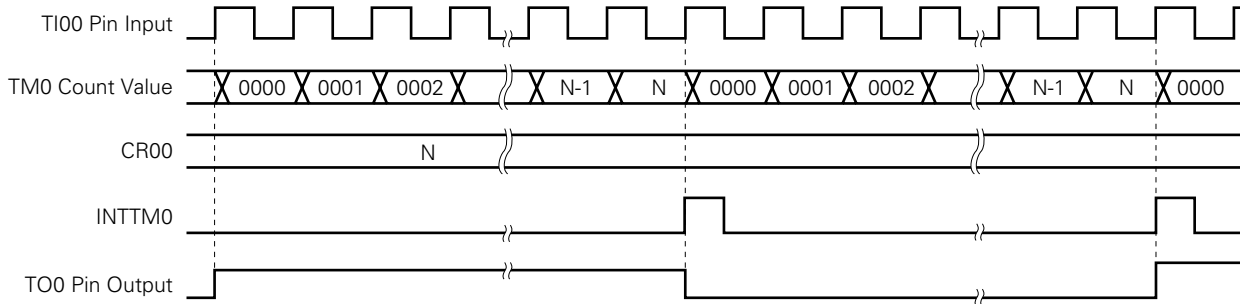
The TO0/P30 pin output status is reversed at intervals of the count value preset to CR00 by setting bit 0 (TOE0) and bit 1 (TOC01) of the 16-bit timer output control register to 1. This enables a square wave with any selected frequency to be output.

Figure 8-29. Control Register Settings in Square-Wave Output Mode



Remark 0/1: Setting 0 or 1 allows another function to be used simultaneously with square-wave output. See the description of the respective control registers for details.

Figure 8-30. Square-Wave Output Operation Timing



www.DataSheet4U.com

Table 8-7. 16-Bit Timer/Event Count Square-Wave Output Ranges

Minimum Pulse Width		Maximum Pulse Width		Resolution	
MCS = 1	MCS = 0	MCS = 1	MCS = 0	MCS = 1	MCS = 0
2 × T100 input cycle		2 ¹⁶ × T100 input cycle		T100 input edge cycle	
—	2 × 1/f _x (400 ns)	—	2 ¹⁶ × 1/f _x (13.1 ms)	—	1/f _x (200 ns)
2 × 1/f _x (400 ns)	2 ² × 1/f _x (800 ns)	2 ¹⁶ × 1/f _x (13.1 ms)	2 ¹⁷ × 1/f _x (26.2 ms)	1/f _x (200 ns)	2 × 1/f _x (400 ns)
2 ² × 1/f _x (800 ns)	2 ³ × 1/f _x (1.6 μs)	2 ¹⁷ × 1/f _x (26.2 ms)	2 ¹⁸ × 1/f _x (52.4 ms)	2 × 1/f _x (400 ns)	2 ² × 1/f _x (800 ns)
2 ³ × 1/f _x (1.6 μs)	2 ⁴ × 1/f _x (3.2 μs)	2 ¹⁸ × 1/f _x (52.4 ms)	2 ¹⁹ × 1/f _x (104.9 ms)	2 ² × 1/f _x (800 ns)	2 ³ × 1/f _x (1.6 μs)
2 × watch timer output cycle		2 ¹⁶ × watch timer output cycle		Watch timer output edge cycle	

- Remarks**
1. f_x : Main system clock oscillation frequency
 2. MCS : Oscillation mode selection register bit 0
 3. Values in parentheses when operated at f_x = 5.0 MHz

8.4.7 One-shot pulse output operation

It is possible to output one-shot pulses synchronized with a software trigger or an external trigger (TI00/P00 pin input).

(1) One-shot pulse output using software trigger

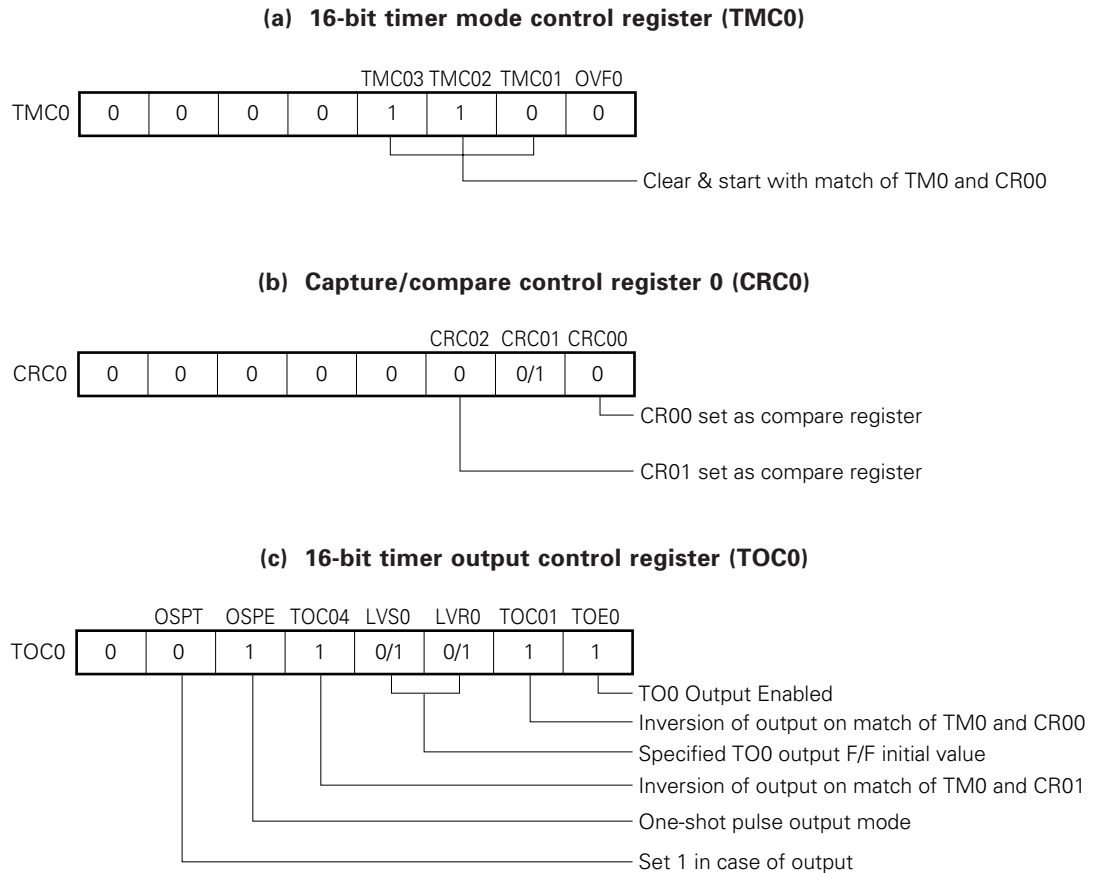
If the 16-bit timer mode control register (TMC0), capture/compare control register 0 (CRC0), and the 16-bit timer output control register (TOC0) are set as shown in Figure 8-31, and 1 is set in bit 6 (OSPT) of TOC0 by software, a one-shot pulse is output from the TO0/P30 pin.

By setting 1 in OSPT, the 16-bit timer/event counter is cleared and started, and output is activated by the count value set beforehand in 16-bit capture/compare register 01 (CR01). Thereafter, output is inactivated by the count value set beforehand in 16-bit capture/compare register 00 (CR00).

TM0 continues to operate after one-shot pulse is output. To stop TM0, 00H must be set to TMC0.

Caution When outputting one-shot pulse, do not set 1 in OSPT. When outputting one-shot pulse again, execute after the INTTM00, or interrupt match signal with CR00, is generated.

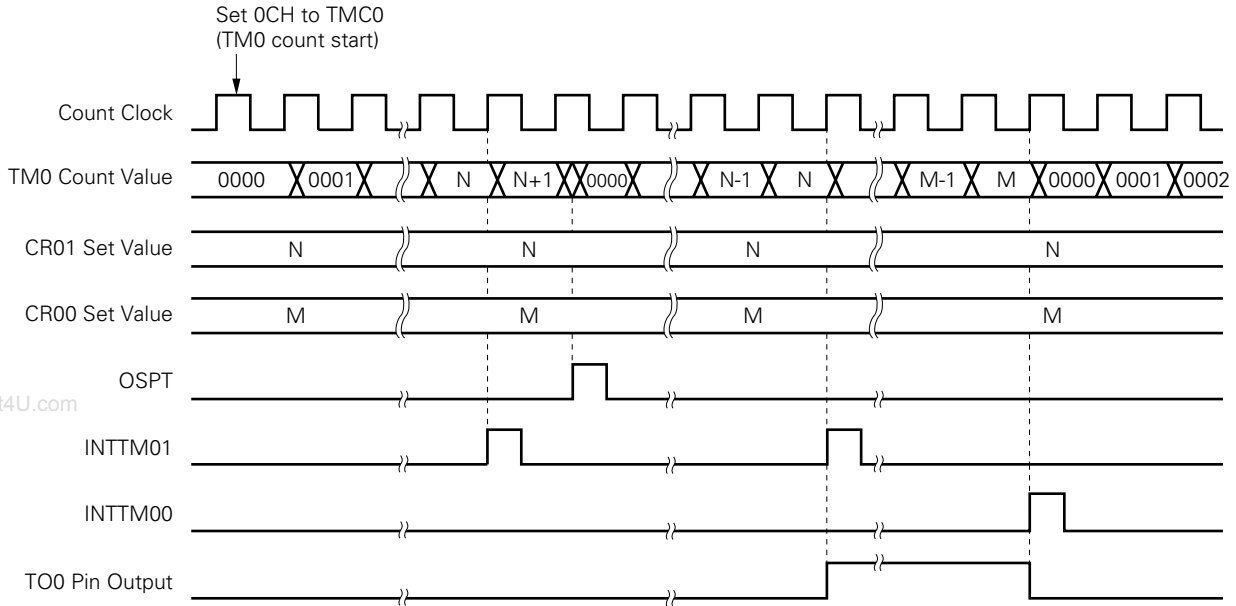
Figure 8-31. Control Register Settings for One-Shot Pulse Output Operation Using Software Trigger



Caution Values in the following range should be set in CR00 and CR01.
 $0000H \leq CR01 < CR00 \leq FFFFH$

Remark 0/1: Setting 0 or 1 allows another function to be used simultaneously with one-shot pulse output. See the description of the respective control registers for details.

Figure 8-32. Timing of One-Shot Pulse Output Operation Using Software Trigger



Caution The 16-bit timer register starts operation at the moment a value other than 0, 0, 0 (operation stop mode) is set to TMC01 to TMC03, respectively.

(2) One-shot pulse output using external trigger

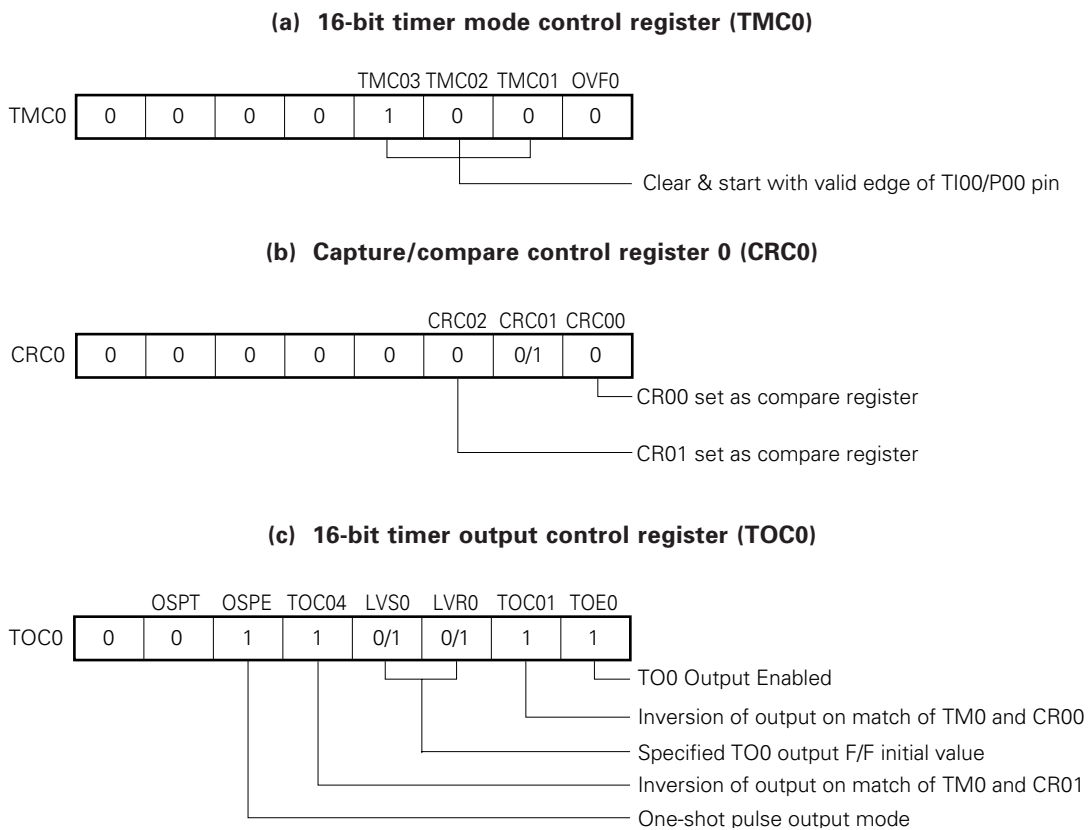
If the 16-bit timer mode control register (TMC0), capture/compare control register 0 (CRC0), and the 16-bit timer output control register (TOC0) are set as shown in Figure 8-33, a one-shot pulse is output from the TO0/P30 pin with a TI00/P00 valid edge as an external trigger.

Any of three edge specifications can be selected—rising, falling, or both edges — as the valid edges for the TI00/P00 pin by means of bits 2 and 3 (ES10 and ES11) of external interrupt mode register 0 (INTM0).

When a valid edge is input to the TI00/P00 pin, the 16-bit timer/event counter is cleared and started, and output is activated by the count values set beforehand in 16-bit capture/compare register 01 (CR01). Thereafter, output is inactivated by the count value set beforehand in 16-bit capture/compare register 00 (CR00).

Caution When outputting one-shot pulses, external trigger is ignored if generated again.

Figure 8-33. Control Register Settings for One-Shot Pulse Output Operation Using External Trigger

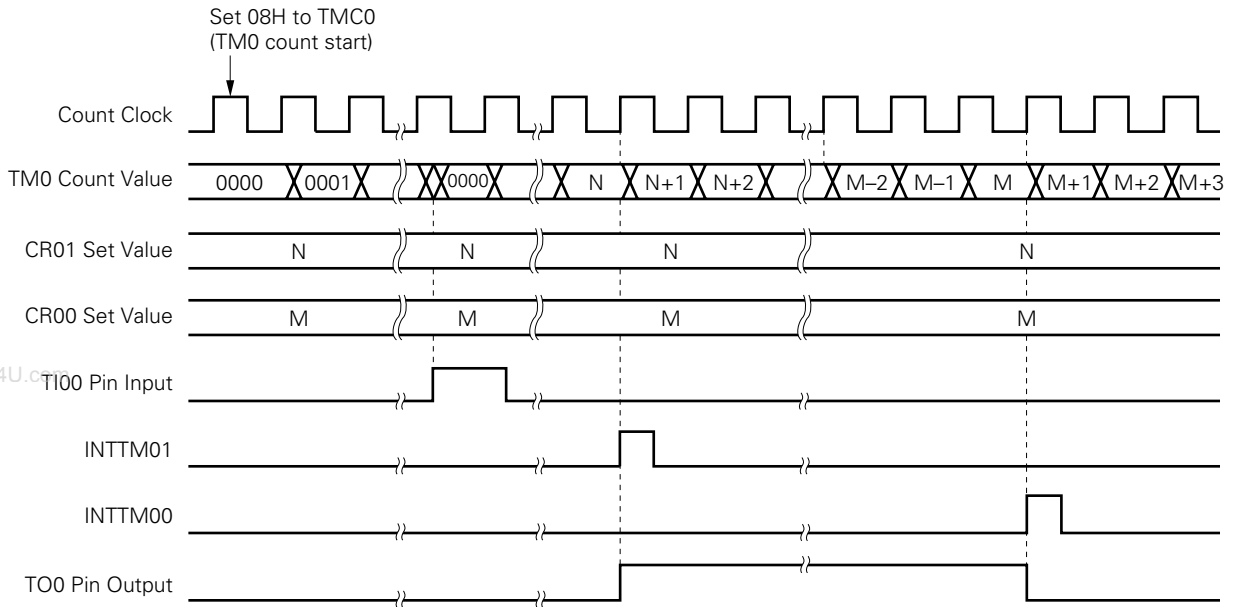


Caution Values in the following range should be set in CR00 and CR01.

$$0000H \leq CR01 < CR00 \leq FFFFH$$

Remark 0/1: Setting 0 or 1 allows another function to be used simultaneously with one-shot pulse output. See the description of the respective control registers for details.

Figure 8-34. Timing of One-Shot Pulse Output Operation Using External Trigger (With Rising Edge Specified)



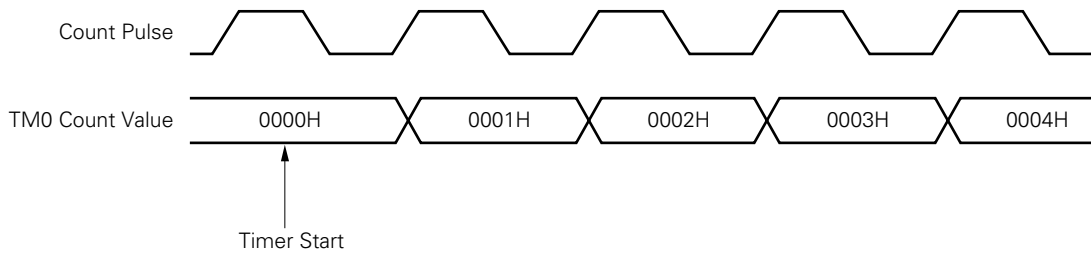
Caution The 16-bit timer register starts operation at the moment a value other than 0, 0, 0 (operation stop mode) is set to TMC01 to TMC03, respectively.

8.5 16-Bit Timer/Event Counter Operating Precautions

(1) Timer start errors

An error with a maximum of one clock may occur concerning the time required for a match signal to be generated after timer start. This is because the 16-bit timer register (TM0) is started asynchronously with the count pulse.

Figure 8-35. 16-Bit Timer Register Start Timing



(2) 16-bit compare register setting

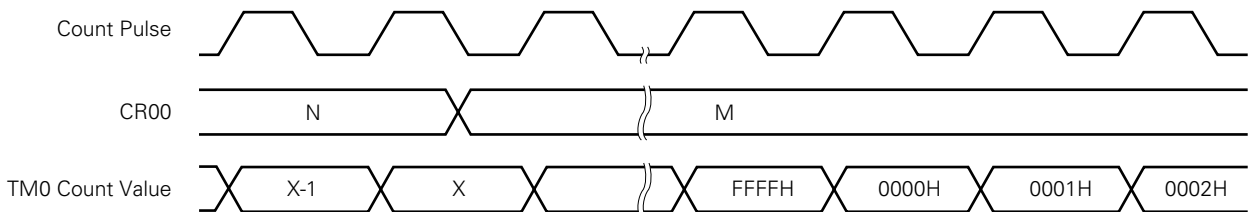
Set a value other than 0000H to the 16-bit capture/compare register 00 (CR00).

Thus, when using the 16-bit capture/compare register as event counter, one-pulse count operation cannot be carried out.

(3) Operation after compare register change during timer count operation

If the value after the 16-bit capture/compare register (CR00) is changed is smaller than that of the 16-bit timer register (TM0), TM0 continues counting, overflows and then restarts counting from 0. Thus, if the value (M) after CR00 change is smaller than that (N) before change, it is necessary to restart the timer after changing CR00.

Figure 8-36. Timings After Change of Compare Register During Timer Count Operation

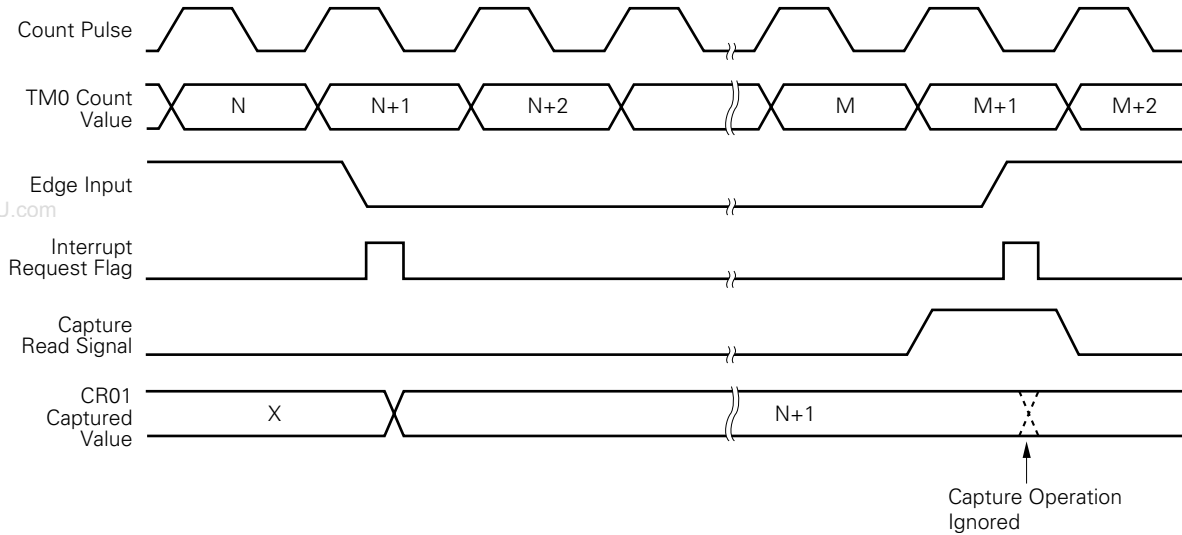


Remark $N > X > M$

(4) Capture register data retention timings

If the valid edge of the TI00/P00 pin is input during 16-bit capture/compare register 01 (CR01) read, CR01 holds data without carrying out capture operation. However, the interrupt request flag (PIF0) is set upon detection of the valid edge.

Figure 8-37. Capture Register Data Retention Timing



(5) Valid edge setting

Set the valid edge of the TI00/INTP0 pin after setting bits 1 to 3 (TMC01 to TMC03) of the 16-bit timer mode control register to 0, 0 and 0, respectively, and then stopping timer operation. Valid edge setting is carried out with bits 2 and 3 (ES10 and ES11) of the external interrupt mode register 0.

(6) Re-trigger of one-shot pulse

(a) One-shot pulse output using software

When outputting one-shot pulse, do not set 1 in OSPT. When outputting one-shot pulse again, execute it after the INTTM00, or interrupt match signal with CR00, is generated.

(b) One-shot pulse output using external trigger

When outputting one-shot pulses, external trigger is ignored if generated again.

(7) Operation of OVF0 flag

OVF0 flag is set to 1 in the following case.

The clear & start mode on match between TM0 and CR00 is selected.

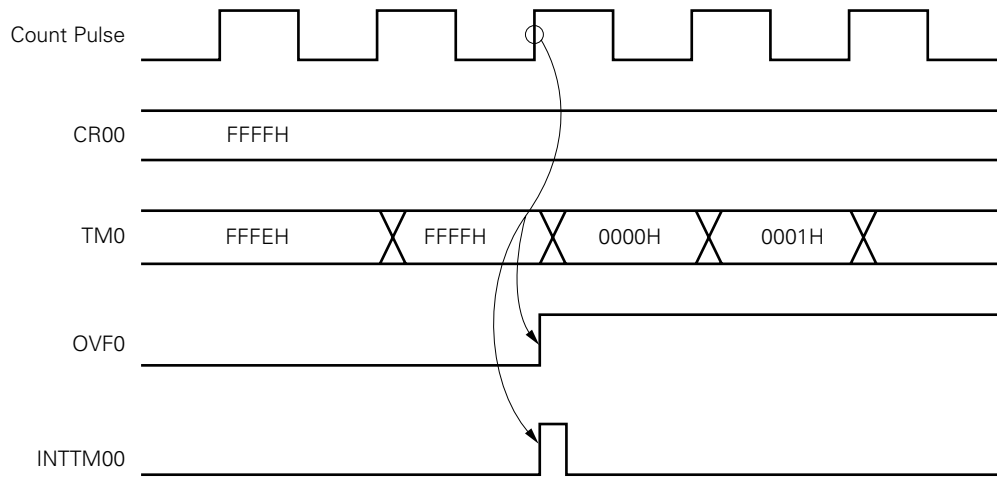


CR00 is set to FFFFH.



When TM0 is counted up from FFFFH to 0000H.

Figure 8-38. Operation Timing of OVF0 Flag



www.DataSheet4U.com

[MEMO]

www.DataSheet4U.com

CHAPTER 9 8-BIT TIMER/EVENT COUNTERS 1 AND 2

9.1 8-Bit Timer/Event Counters 1 and 2 Functions

For the 8-bit timer/event counters 1 and 2, two modes are available. One is a mode for two-channel 8-bit timer/event counters to be used separately (the 8-bit timer/event counter mode) and the other is a mode for the 8-bit timer/event counter to be used as 16-bit timer/event counter (the 16-bit timer/event counter mode).

9.1.1 8-bit timer/event counter mode

The 8-bit timer/event counters 1 and 2 (TM1 and TM2) have the following functions.

- Interval timer
- External event counter
- Square-wave output

(1) 8-bit interval timer

Interrupts are generated at the preset time intervals.

Table 9-1. 8-Bit Timer/Event Counters 1 and 2 Interval Times

Minimum Interval Time		Maximum Interval Time		Resolution	
MCS = 1	MCS = 0	MCS = 1	MCS = 0	MCS = 1	MCS = 0
$2 \times 1/f_x$ (400 ns)	$2^2 \times 1/f_x$ (800 ns)	$2^9 \times 1/f_x$ (102.4 μ s)	$2^{10} \times 1/f_x$ (204.8 μ s)	$2 \times 1/f_x$ (400 ns)	$2^2 \times 1/f_x$ (800 ns)
$2^2 \times 1/f_x$ (800 ns)	$2^3 \times 1/f_x$ (1.6 μ s)	$2^{10} \times 1/f_x$ (204.8 μ s)	$2^{11} \times 1/f_x$ (409.6 μ s)	$2^2 \times 1/f_x$ (800 ns)	$2^3 \times 1/f_x$ (1.6 μ s)
$2^3 \times 1/f_x$ (1.6 μ s)	$2^4 \times 1/f_x$ (3.2 μ s)	$2^{11} \times 1/f_x$ (409.6 μ s)	$2^{12} \times 1/f_x$ (819.2 μ s)	$2^3 \times 1/f_x$ (1.6 μ s)	$2^4 \times 1/f_x$ (3.2 μ s)
$2^4 \times 1/f_x$ (3.2 μ s)	$2^5 \times 1/f_x$ (6.4 μ s)	$2^{12} \times 1/f_x$ (819.2 μ s)	$2^{13} \times 1/f_x$ (1.64 ms)	$2^4 \times 1/f_x$ (3.2 μ s)	$2^5 \times 1/f_x$ (6.4 μ s)
$2^5 \times 1/f_x$ (6.4 μ s)	$2^6 \times 1/f_x$ (12.8 μ s)	$2^{13} \times 1/f_x$ (1.64 ms)	$2^{14} \times 1/f_x$ (3.28 ms)	$2^5 \times 1/f_x$ (6.4 μ s)	$2^6 \times 1/f_x$ (12.8 μ s)
$2^6 \times 1/f_x$ (12.8 μ s)	$2^7 \times 1/f_x$ (25.6 μ s)	$2^{14} \times 1/f_x$ (3.28 ms)	$2^{15} \times 1/f_x$ (6.55 ms)	$2^6 \times 1/f_x$ (12.8 μ s)	$2^7 \times 1/f_x$ (25.6 μ s)
$2^7 \times 1/f_x$ (25.6 μ s)	$2^8 \times 1/f_x$ (51.2 μ s)	$2^{15} \times 1/f_x$ (6.55 ms)	$2^{16} \times 1/f_x$ (13.1 ms)	$2^7 \times 1/f_x$ (25.6 μ s)	$2^8 \times 1/f_x$ (51.2 μ s)
$2^8 \times 1/f_x$ (51.2 μ s)	$2^9 \times 1/f_x$ (102.4 μ s)	$2^{16} \times 1/f_x$ (13.1 ms)	$2^{17} \times 1/f_x$ (26.2 ms)	$2^8 \times 1/f_x$ (51.2 μ s)	$2^9 \times 1/f_x$ (102.4 μ s)
$2^9 \times 1/f_x$ (102.4 μ s)	$2^{10} \times 1/f_x$ (204.8 μ s)	$2^{17} \times 1/f_x$ (26.2 ms)	$2^{18} \times 1/f_x$ (52.4 ms)	$2^9 \times 1/f_x$ (102.4 μ s)	$2^{10} \times 1/f_x$ (204.8 μ s)
$2^{11} \times 1/f_x$ (409.6 μ s)	$2^{12} \times 1/f_x$ (819.2 μ s)	$2^{19} \times 1/f_x$ (104.9 ms)	$2^{20} \times 1/f_x$ (209.7 ms)	$2^{11} \times 1/f_x$ (409.6 μ s)	$2^{12} \times 1/f_x$ (819.2 μ s)

- Remarks**
1. f_x : Main system clock oscillation frequency
 2. MCS : Oscillation mode selection register bit 0
 3. Values in parentheses when operated at $f_x = 5.0$ MHz.

(2) External event counter

The number of pulses of an externally input signal can be measured.

(3) Square-wave output

A square wave with any selected frequency can be output.

Table 9-2. 8-Bit Timer/Event Counters 1 and 2 Square-Wave Output Ranges

Minimum Pulse Width		Maximum Pulse Width		Resolution	
MCS = 1	MCS = 0	MCS = 1	MCS = 0	MCS = 1	MCS = 0
$2 \times 1/f_x$ (400 ns)	$2^2 \times 1/f_x$ (800 ns)	$2^9 \times 1/f_x$ (102.4 μ s)	$2^{10} \times 1/f_x$ (204.8 μ s)	$2 \times 1/f_x$ (400 ns)	$2^2 \times 1/f_x$ (800 ns)
$2^2 \times 1/f_x$ (800 ns)	$2^3 \times 1/f_x$ (1.6 μ s)	$2^{10} \times 1/f_x$ (204.8 μ s)	$2^{11} \times 1/f_x$ (409.6 μ s)	$2^2 \times 1/f_x$ (800 ns)	$2^3 \times 1/f_x$ (1.6 μ s)
$2^3 \times 1/f_x$ (1.6 μ s)	$2^4 \times 1/f_x$ (3.2 μ s)	$2^{11} \times 1/f_x$ (409.6 μ s)	$2^{12} \times 1/f_x$ (819.2 μ s)	$2^3 \times 1/f_x$ (1.6 μ s)	$2^4 \times 1/f_x$ (3.2 μ s)
$2^4 \times 1/f_x$ (3.2 μ s)	$2^5 \times 1/f_x$ (6.4 μ s)	$2^{12} \times 1/f_x$ (819.2 μ s)	$2^{13} \times 1/f_x$ (1.64 ms)	$2^4 \times 1/f_x$ (3.2 μ s)	$2^5 \times 1/f_x$ (6.4 μ s)
$2^5 \times 1/f_x$ (6.4 μ s)	$2^6 \times 1/f_x$ (12.8 μ s)	$2^{13} \times 1/f_x$ (1.64 ms)	$2^{14} \times 1/f_x$ (3.28 ms)	$2^5 \times 1/f_x$ (6.4 μ s)	$2^6 \times 1/f_x$ (12.8 μ s)
$2^6 \times 1/f_x$ (12.8 μ s)	$2^7 \times 1/f_x$ (25.6 μ s)	$2^{14} \times 1/f_x$ (3.28 ms)	$2^{15} \times 1/f_x$ (6.55 ms)	$2^6 \times 1/f_x$ (12.8 μ s)	$2^7 \times 1/f_x$ (25.6 μ s)
$2^7 \times 1/f_x$ (25.6 μ s)	$2^8 \times 1/f_x$ (51.2 μ s)	$2^{15} \times 1/f_x$ (6.55 ms)	$2^{16} \times 1/f_x$ (13.1 ms)	$2^7 \times 1/f_x$ (25.6 μ s)	$2^8 \times 1/f_x$ (51.2 μ s)
$2^8 \times 1/f_x$ (51.2 μ s)	$2^9 \times 1/f_x$ (102.4 μ s)	$2^{16} \times 1/f_x$ (13.1 ms)	$2^{17} \times 1/f_x$ (26.2 ms)	$2^8 \times 1/f_x$ (51.2 μ s)	$2^9 \times 1/f_x$ (102.4 μ s)
$2^9 \times 1/f_x$ (102.4 μ s)	$2^{10} \times 1/f_x$ (204.8 μ s)	$2^{17} \times 1/f_x$ (26.2 ms)	$2^{18} \times 1/f_x$ (52.4 ms)	$2^9 \times 1/f_x$ (102.4 μ s)	$2^{10} \times 1/f_x$ (204.8 μ s)
$2^{11} \times 1/f_x$ (409.6 μ s)	$2^{12} \times 1/f_x$ (819.2 μ s)	$2^{19} \times 1/f_x$ (104.9 ms)	$2^{20} \times 1/f_x$ (209.7 ms)	$2^{11} \times 1/f_x$ (409.6 μ s)	$2^{12} \times 1/f_x$ (819.2 μ s)

- Remarks**
1. f_x : Main system clock oscillation frequency
 2. MCS : Oscillation mode selection register bit 0
 3. Values in parentheses when operated at $f_x = 5.0$ MHz.

9.1.2 16-bit timer/event counter mode

(1) 16-bit interval timer

Interrupts can be generated at the preset time intervals.

Table 9-3. Interval Times when 8-Bit Timer/Event Counters 1 and 2 are Used as 16-Bit Timer/Event Counters

Minimum Interval Time		Maximum Interval Time		Resolution	
MCS = 1	MCS = 0	MCS = 1	MCS = 0	MCS = 1	MCS = 0
$2 \times 1/f_x$ (400 ns)	$2^2 \times 1/f_x$ (800 ns)	$2^{17} \times 1/f_x$ (26.2 ms)	$2^{18} \times 1/f_x$ (52.4 ms)	$2 \times 1/f_x$ (400 ns)	$2^2 \times 1/f_x$ (800 ns)
$2^2 \times 1/f_x$ (800 ns)	$2^3 \times 1/f_x$ (1.6 μ s)	$2^{18} \times 1/f_x$ (52.4 ms)	$2^{19} \times 1/f_x$ (104.9 ms)	$2^2 \times 1/f_x$ (800 ns)	$2^3 \times 1/f_x$ (1.6 μ s)
$2^3 \times 1/f_x$ (1.6 μ s)	$2^4 \times 1/f_x$ (3.2 μ s)	$2^{19} \times 1/f_x$ (104.9 ms)	$2^{20} \times 1/f_x$ (209.7 ms)	$2^3 \times 1/f_x$ (1.6 μ s)	$2^4 \times 1/f_x$ (3.2 μ s)
$2^4 \times 1/f_x$ (3.2 μ s)	$2^5 \times 1/f_x$ (6.4 μ s)	$2^{20} \times 1/f_x$ (209.7 ms)	$2^{21} \times 1/f_x$ (419.4 ms)	$2^4 \times 1/f_x$ (3.2 μ s)	$2^5 \times 1/f_x$ (6.4 μ s)
$2^5 \times 1/f_x$ (6.4 μ s)	$2^6 \times 1/f_x$ (12.8 μ s)	$2^{21} \times 1/f_x$ (419.4 ms)	$2^{22} \times 1/f_x$ (838.9 ms)	$2^5 \times 1/f_x$ (6.4 μ s)	$2^6 \times 1/f_x$ (12.8 μ s)
$2^6 \times 1/f_x$ (12.8 μ s)	$2^7 \times 1/f_x$ (25.6 μ s)	$2^{22} \times 1/f_x$ (838.9 ms)	$2^{23} \times 1/f_x$ (1.7 s)	$2^6 \times 1/f_x$ (12.8 μ s)	$2^7 \times 1/f_x$ (25.6 μ s)
$2^7 \times 1/f_x$ (25.6 μ s)	$2^8 \times 1/f_x$ (51.2 μ s)	$2^{23} \times 1/f_x$ (1.7 s)	$2^{24} \times 1/f_x$ (3.4 s)	$2^7 \times 1/f_x$ (25.6 μ s)	$2^8 \times 1/f_x$ (51.2 μ s)
$2^8 \times 1/f_x$ (51.2 μ s)	$2^9 \times 1/f_x$ (102.4 μ s)	$2^{24} \times 1/f_x$ (3.4 s)	$2^{25} \times 1/f_x$ (6.7 s)	$2^8 \times 1/f_x$ (51.2 μ s)	$2^9 \times 1/f_x$ (102.4 μ s)
$2^9 \times 1/f_x$ (102.4 μ s)	$2^{10} \times 1/f_x$ (204.8 μ s)	$2^{25} \times 1/f_x$ (6.7 s)	$2^{26} \times 1/f_x$ (13.4 s)	$2^9 \times 1/f_x$ (102.4 μ s)	$2^{10} \times 1/f_x$ (204.8 μ s)
$2^{11} \times 1/f_x$ (409.6 μ s)	$2^{12} \times 1/f_x$ (819.2 μ s)	$2^{27} \times 1/f_x$ (26.8 s)	$2^{28} \times 1/f_x$ (53.7 s)	$2^{11} \times 1/f_x$ (409.6 μ s)	$2^{12} \times 1/f_x$ (819.2 μ s)

- Remarks**
1. f_x : Main system clock oscillation frequency
 2. MCS : Oscillation mode selection register bit 0
 3. Values in parentheses when operated at $f_x = 5.0$ MHz.

(2) External event counter

The number of pulses of an externally input signal can be measured.

(3) Square-wave output

A square wave with any selected frequency can be output.

Table 9-4. Square-Wave Output Ranges when 8-Bit Timer/Event Counters 1 and 2 are Used as 16-Bit Timer/Event Counters

Minimum Pulse Width		Maximum Pulse Width		Resolution	
MCS = 1	MCS = 0	MCS = 1	MCS = 0	MCS = 1	MCS = 0
$2 \times 1/f_x$ (400 ns)	$2^2 \times 1/f_x$ (800 ns)	$2^{17} \times 1/f_x$ (26.2 ms)	$2^{18} \times 1/f_x$ (52.4 ms)	$2 \times 1/f_x$ (400 ns)	$2^2 \times 1/f_x$ (800 ns)
$2^2 \times 1/f_x$ (800 ns)	$2^3 \times 1/f_x$ (1.6 μ s)	$2^{18} \times 1/f_x$ (52.4 ms)	$2^{19} \times 1/f_x$ (104.9 ms)	$2^2 \times 1/f_x$ (800 ns)	$2^3 \times 1/f_x$ (1.6 μ s)
$2^3 \times 1/f_x$ (1.6 μ s)	$2^4 \times 1/f_x$ (3.2 μ s)	$2^{19} \times 1/f_x$ (104.9 ms)	$2^{20} \times 1/f_x$ (209.7 ms)	$2^3 \times 1/f_x$ (1.6 μ s)	$2^4 \times 1/f_x$ (3.2 μ s)
$2^4 \times 1/f_x$ (3.2 μ s)	$2^5 \times 1/f_x$ (6.4 μ s)	$2^{20} \times 1/f_x$ (209.7 ms)	$2^{21} \times 1/f_x$ (419.4 ms)	$2^4 \times 1/f_x$ (3.2 μ s)	$2^5 \times 1/f_x$ (6.4 μ s)
$2^5 \times 1/f_x$ (6.4 μ s)	$2^6 \times 1/f_x$ (12.8 μ s)	$2^{21} \times 1/f_x$ (419.4 ms)	$2^{22} \times 1/f_x$ (838.9 ms)	$2^5 \times 1/f_x$ (6.4 μ s)	$2^6 \times 1/f_x$ (12.8 μ s)
$2^6 \times 1/f_x$ (12.8 μ s)	$2^7 \times 1/f_x$ (25.6 μ s)	$2^{22} \times 1/f_x$ (838.9 ms)	$2^{23} \times 1/f_x$ (1.7 s)	$2^6 \times 1/f_x$ (12.8 μ s)	$2^7 \times 1/f_x$ (25.6 μ s)
$2^7 \times 1/f_x$ (25.6 μ s)	$2^8 \times 1/f_x$ (51.2 μ s)	$2^{23} \times 1/f_x$ (1.7 s)	$2^{24} \times 1/f_x$ (3.4 s)	$2^7 \times 1/f_x$ (25.6 μ s)	$2^8 \times 1/f_x$ (51.2 μ s)
$2^8 \times 1/f_x$ (51.2 μ s)	$2^9 \times 1/f_x$ (102.4 μ s)	$2^{24} \times 1/f_x$ (3.4 s)	$2^{25} \times 1/f_x$ (6.7 s)	$2^8 \times 1/f_x$ (51.2 μ s)	$2^9 \times 1/f_x$ (102.4 μ s)
$2^9 \times 1/f_x$ (102.4 μ s)	$2^{10} \times 1/f_x$ (204.8 μ s)	$2^{25} \times 1/f_x$ (6.7 s)	$2^{26} \times 1/f_x$ (13.4 s)	$2^9 \times 1/f_x$ (102.4 μ s)	$2^{10} \times 1/f_x$ (204.8 μ s)
$2^{11} \times 1/f_x$ (409.6 μ s)	$2^{12} \times 1/f_x$ (819.2 μ s)	$2^{27} \times 1/f_x$ (26.8 s)	$2^{28} \times 1/f_x$ (53.7 s)	$2^{11} \times 1/f_x$ (409.6 μ s)	$2^{12} \times 1/f_x$ (819.2 μ s)

- Remarks**
1. f_x : Main system clock oscillation frequency
 2. MCS : Oscillation mode selection register bit 0
 3. Values in parentheses when operated at $f_x = 5.0$ MHz.

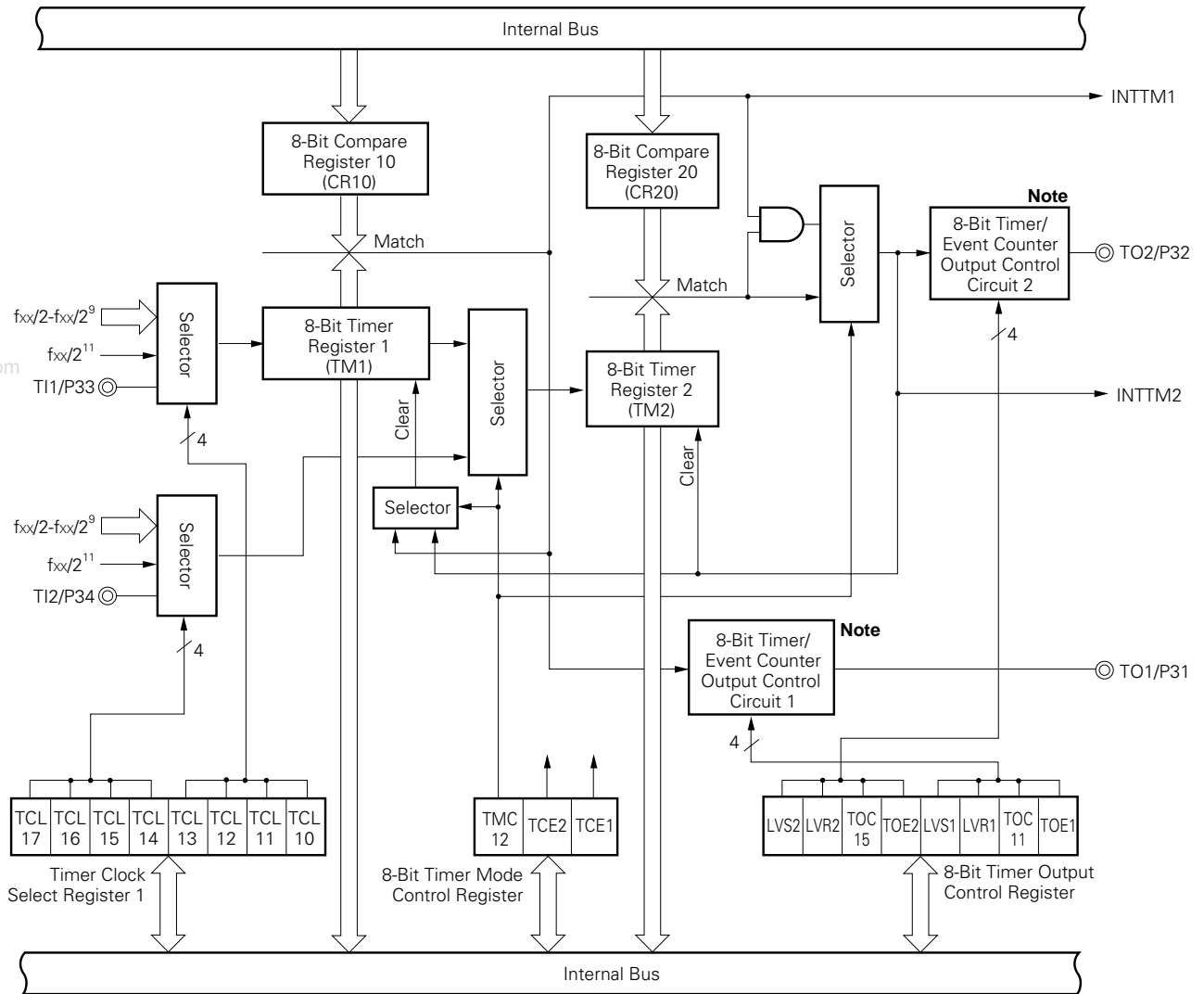
9.2 8-Bit Timer/Event Counters 1 and 2 Configurations

The 8-bit timer/event counters 1 and 2 consist of the following hardware.

Table 9-5. 8-Bit Timer/Event Counters 1 and 2 Configurations

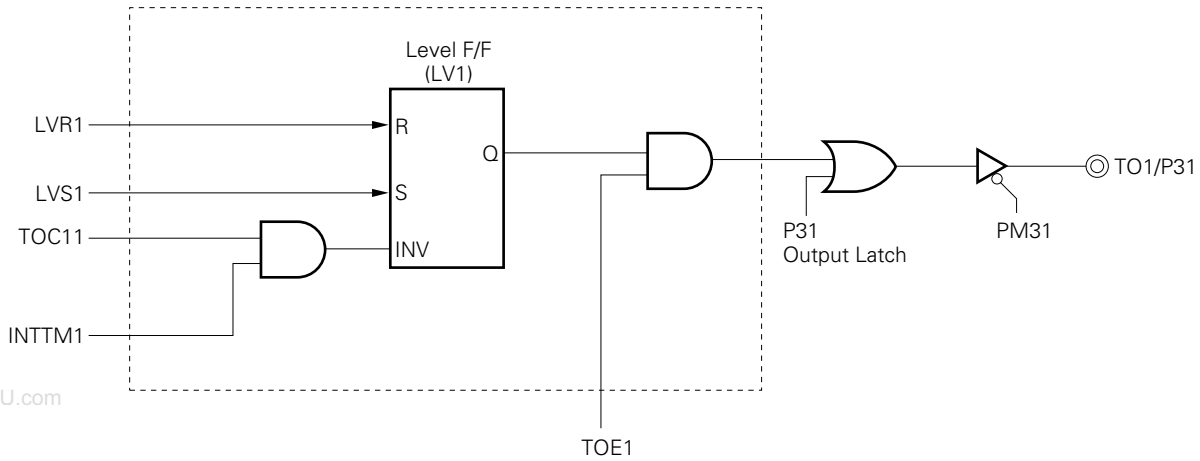
Item	Configuration
Timer register	8 bits × 2 (TM1, TM2)
Register	Compare register: 8 bits × 2 (CR10, CR20)
Timer output	2 (TO1, TO2)
Control register	Timer clock select register 1 (TCL1) 8-bit timer mode control register 1 (TMC1) 8-bit timer output control register (TOC1) Port mode register 3 (PM3)

Figure 9-1. 8-Bit Timer/Event Counters 1 and 2 Block Diagram



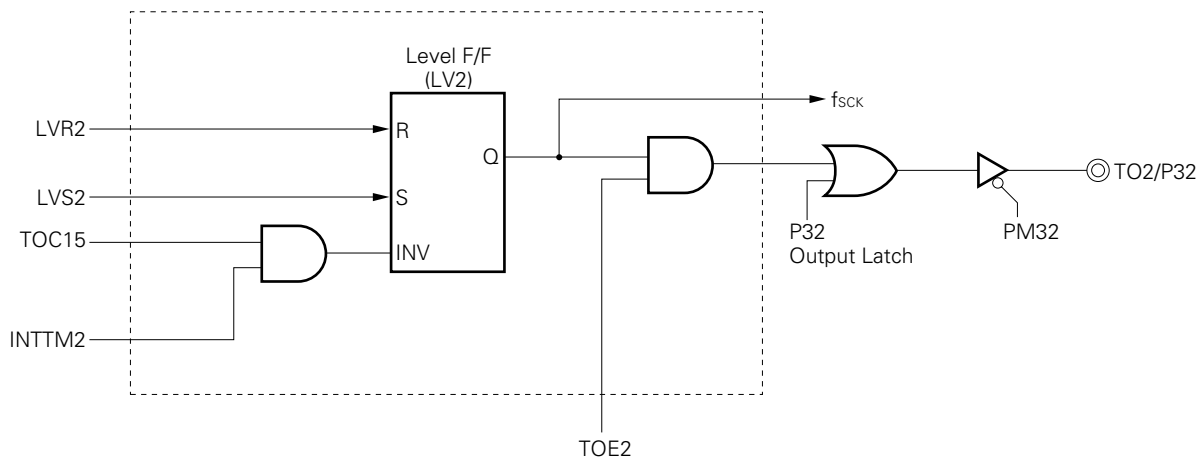
Note Refer to Figures 9-2 and 9-3 for details of 8-bit timer/event counter output control circuits 1 and 2, respectively.

Figure 9-2. Block Diagram of 8-Bit Timer/Event Counter Output Control Circuit 1



Remark The section in the broken line is an output control circuit.

Figure 9-3. Block Diagram of 8-Bit Timer/Event Counter Output Control Circuit 2



- Remarks**
1. The section in the broken line is an output control circuit.
 2. fsc : Serial clock frequency

(1) Compare registers 10 and 20 (CR10, CR20)

These are 8-bit registers to compare the value set to CR10 to the 8-bit timer register 1 (TM1) count value, and the value set to CR20 to the 8-bit timer register 2 (TM2) count value, and, if they match, generate an interrupt request (INTTM1 and INTTM2, respectively).

CR10 and CR20 are set with an 8-bit memory manipulation instruction. They cannot be set with a 16-bit memory manipulation instruction. When the compare register is used as 8-bit timer/event counter, the 00H to FFH values can be set. When the compare register is used as 16-bit timer/event counter, the 0000H to FFFFH values can be set.

$\overline{\text{RESET}}$ input makes CR10 and CR20 undefined.

Caution When using the compare register as 16-bit timer/event counter, be sure to set data after stopping timer operation.

www.DataSheet4U.com

(2) 8-bit timer registers 1, 2 (TM1, TM2)

These are 8-bit registers to count count pulses.

When TM1 and TM2 are used in the 8-bit timer \times 2-channel mode, they are read with an 8-bit memory manipulation instruction. When TM1 and TM2 are used as 16-bit timer \times 1-channel mode, 16-bit timer (TMS) is read with a 16-bit memory manipulation instruction.

$\overline{\text{RESET}}$ input sets TM1 and TM2 to 00H.

9.3 8-Bit Timer/Event Counters 1 and 2 Control Registers

The following four types of registers are used to control the 8-bit timer/event counter.

- Timer clock select register 1 (TCL1)
- 8-bit timer mode control register 1 (TMC1)
- 8-bit timer output control register (TOC1)
- Port mode register 3 (PM3)

(1) Timer clock select register 1 (TCL1)

This register sets count clocks of 8-bit timer registers 1 and 2.

TCL1 is set with an 8-bit memory manipulation instruction.

www.DataSheet4U.com RESET input sets TCL1 to 00H.

Figure 9-4. Timer Clock Select Register 1 Format

Symbol	7	6	5	4	3	2	1	0	Address	After Reset	R/W
TCL1	TCL17	TCL16	TCL15	TCL14	TCL13	TCL12	TCL11	TCL10	FF41H	00H	R/W

TCL13				TCL12				TCL11				TCL10				8-Bit Timer Register 1 Count Clock Selection		
																MCS=1		MCS=0
0	0	0	0	T11 falling edge														
0	0	0	1	T11 rising edge														
0	1	1	0	$f_{xx}/2$	$f_x/2$ (2.5 MHz)				$f_x/2^2$ (1.25 MHz)									
0	1	1	1	$f_{xx}/2^2$	$f_x/2^2$ (1.25 MHz)				$f_x/2^3$ (625 kHz)									
1	0	0	0	$f_{xx}/2^3$	$f_x/2^3$ (625 kHz)				$f_x/2^4$ (313 kHz)									
1	0	0	1	$f_{xx}/2^4$	$f_x/2^4$ (313 kHz)				$f_x/2^5$ (156 kHz)									
1	0	1	0	$f_{xx}/2^5$	$f_x/2^5$ (156 kHz)				$f_x/2^6$ (78.1 kHz)									
1	0	1	1	$f_{xx}/2^6$	$f_x/2^6$ (78.1 kHz)				$f_x/2^7$ (39.1 kHz)									
1	1	0	0	$f_{xx}/2^7$	$f_x/2^7$ (39.1 kHz)				$f_x/2^8$ (19.5 kHz)									
1	1	0	1	$f_{xx}/2^8$	$f_x/2^8$ (19.5 kHz)				$f_x/2^9$ (9.8 kHz)									
1	1	1	0	$f_{xx}/2^9$	$f_x/2^9$ (9.8 kHz)				$f_x/2^{10}$ (4.9 kHz)									
1	1	1	1	$f_{xx}/2^{11}$	$f_x/2^{11}$ (2.4 kHz)				$f_x/2^{12}$ (1.2 kHz)									
Other than above				Setting prohibited														

TCL17				TCL16				TCL15				TCL14				8-Bit Timer Register 2 Count Clock Selection		
																MCS=1		MCS=0
0	0	0	0	T12 falling edge														
0	0	0	1	T12 rising edge														
0	1	1	0	$f_{xx}/2$	$f_x/2$ (2.5 MHz)				$f_x/2^2$ (1.25 MHz)									
0	1	1	1	$f_{xx}/2^2$	$f_x/2^2$ (1.25 MHz)				$f_x/2^3$ (625 kHz)									
1	0	0	0	$f_{xx}/2^3$	$f_x/2^3$ (625 kHz)				$f_x/2^4$ (313 kHz)									
1	0	0	1	$f_{xx}/2^4$	$f_x/2^4$ (313 kHz)				$f_x/2^5$ (156 kHz)									
1	0	1	0	$f_{xx}/2^5$	$f_x/2^5$ (156 kHz)				$f_x/2^6$ (78.1 kHz)									
1	0	1	1	$f_{xx}/2^6$	$f_x/2^6$ (78.1 kHz)				$f_x/2^7$ (39.1 kHz)									
1	1	0	0	$f_{xx}/2^7$	$f_x/2^7$ (39.1 kHz)				$f_x/2^8$ (19.5 kHz)									
1	1	0	1	$f_{xx}/2^8$	$f_x/2^8$ (19.5 kHz)				$f_x/2^9$ (9.8 kHz)									
1	1	1	0	$f_{xx}/2^9$	$f_x/2^9$ (9.8 kHz)				$f_x/2^{10}$ (4.9 kHz)									
1	1	1	1	$f_{xx}/2^{11}$	$f_x/2^{11}$ (2.4 kHz)				$f_x/2^{12}$ (1.2 kHz)									
Other than above				Setting prohibited														

Caution When rewriting TCL1 to other data, stop the timer operation beforehand.

- Remarks**
1. f_{xx} : Main system clock frequency (f_x or $f_x/2$)
 2. f_x : Main system clock oscillation frequency
 3. T11 : 8-bit timer register 1 input pin
 4. T12 : 8-bit timer register 2 input pin
 5. MCS : Oscillation mode selection register bit 0
 6. Figures in parentheses apply to operation with $f_x = 5.0$ MHz

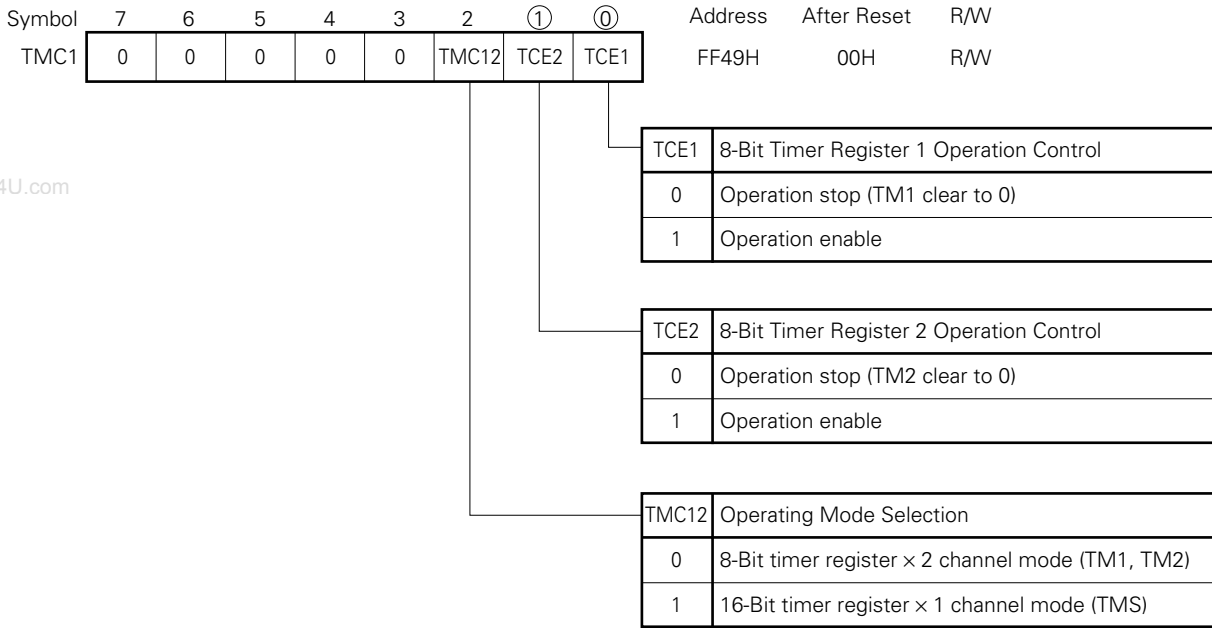
(2) 8-bit timer mode control register (TMC1)

This register enables/stops operation of 8-bit timer registers 1 and 2 and sets the operating mode of 8-bit timer register 2.

TMC1 is set with a 1-bit or 8-bit memory manipulation instruction.

RESET input sets TMC1 to 00H.

Figure 9-5. 8-Bit Timer Mode Control Register Format



- Cautions**
1. Switch the operating mode after stopping timer operation.
 2. When used as 16-bit timer register, TCE1 should be used for operation enable/stop.

(3) 8-bit timer output control register (TOC1)

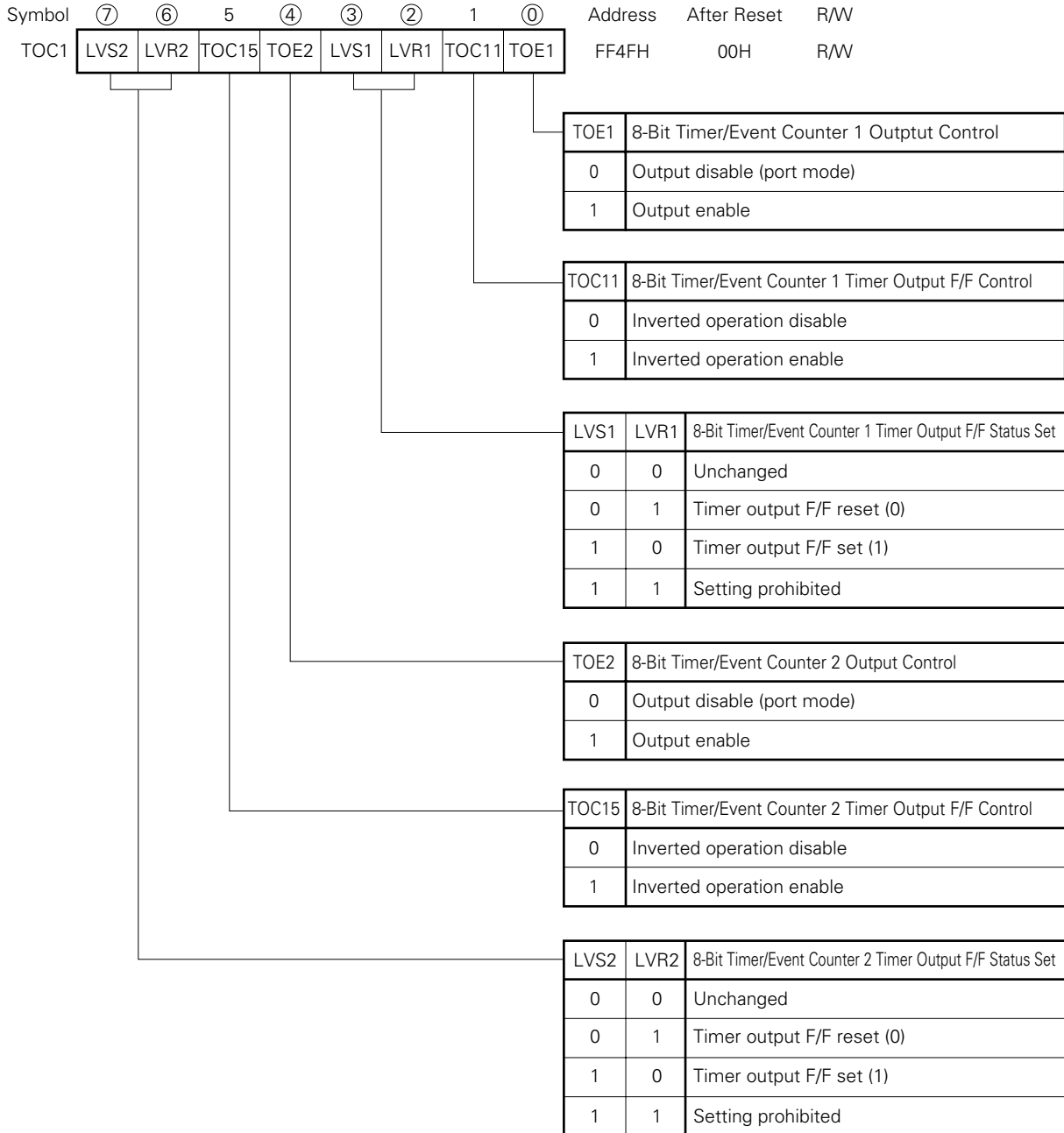
This register controls operation of 8-bit timer/event counter output control circuits 1 and 2.

It sets/resets the R-S flip-flops (LV1 and LV2) and enables/disables inversion and 8-bit timer output of 8-bit timer registers 1 and 2.

TOC1 is set with a 1-bit or 8-bit memory manipulation instruction.

$\overline{\text{RESET}}$ input sets TOC1 to 00H.

Figure 9-6. 8-Bit Timer Output Control Register Format



Cautions 1. Be sure to set TOC1 after stopping timer operation.

2. After data setting, 0 can be read from LVS1, LVS2, LVR1 and LVR2.

(4) Port mode register 3 (PM3)

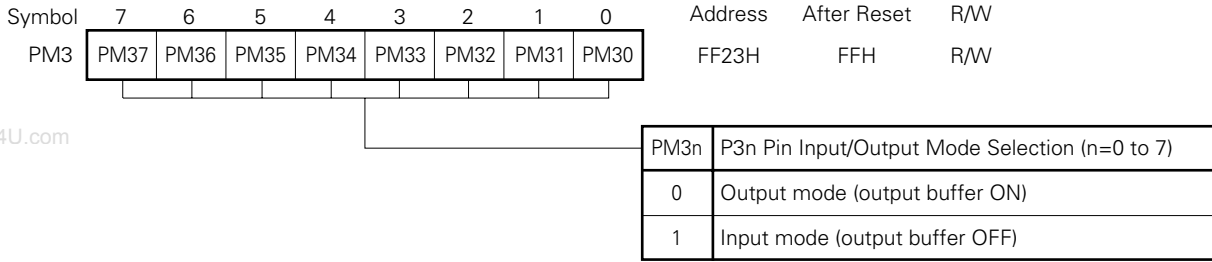
This register sets port 3 input/output in 1-bit units.

When using the P31/TO1 and P32/TO2 pins for timer output, set PM31, PM32, and output latches of P31 and P32 to 0.

PM3 is set with a 1-bit or 8-bit memory manipulation instruction.

$\overline{\text{RESET}}$ input sets PM3 to FFH.

Figure 9-7. Port Mode Register 3 Format



www.DataSheet4U.com

9.4 8-Bit Timer/Event Counters 1 and 2 Operations

9.4.1 8-bit timer/event counter mode

(1) Interval timer operations

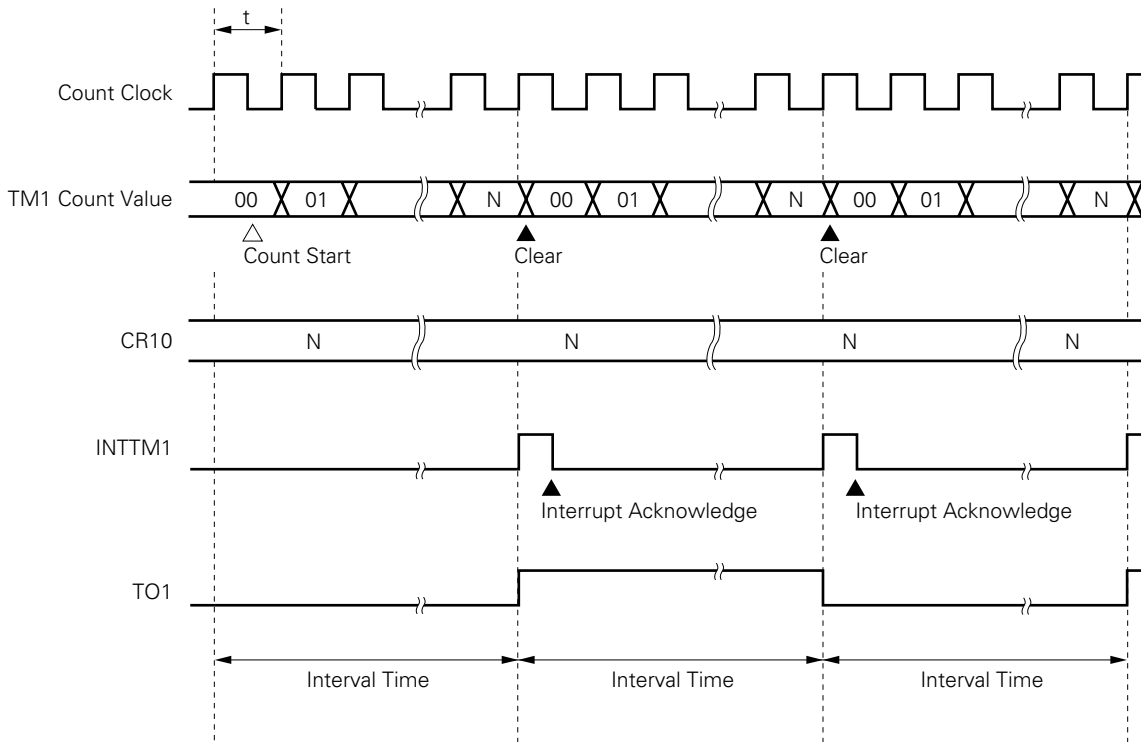
The 8-bit timer/event counters 1 and 2 operate as interval timers which generate interrupts repeatedly at intervals of the count value preset to 8-bit compare registers 10 and 20 (CR10 and CR20).

When the count values of the 8-bit timer registers 1 and 2 (TM1 and TM2) match the values set to CR10 and CR20, counting continues with the TM1 and TM2 values cleared to 0 and the interrupt request signals (INTTM1 and INTTM2) are generated.

Count clock of the 8-bit timer register 1 (TM1) can be selected with bits 0 to 3 (TCL10 to TCL13) of the timer clock select register 1 (TCL1). Count clock of the 8-bit timer register 2 (TM2) can be selected with bits 4 to 7 (TCL14 to TCL17) of the timer clock select register 1 (TCL1).

www.DataSheet4U.com

Figure 9-8. Interval Timer Operation Timings



Remark Interval time = $(N + 1) \times t$: N = 00H to FFH

Table 9-6. 8-Bit Timer/Event Counter 1 Interval Time

TCL13	TCL12	TCL11	TCL10	Minimum Interval Time		Maximum Interval Time		Resolution	
				MCS = 1	MCS = 0	MCS = 1	MCS = 0	MCS = 1	MCS = 0
0	0	0	0	T11 input cycle		$2^8 \times$ T11 input cycle		T11 input edge cycle	
0	0	0	1	T11 input cycle		$2^8 \times$ T11 input cycle		T11 input edge cycle	
0	1	1	0	$2 \times 1/f_x$ (400 ns)	$2^2 \times 1/f_x$ (800 ns)	$2^9 \times 1/f_x$ (102.4 μ s)	$2^{10} \times 1/f_x$ (204.8 μ s)	$2 \times 1/f_x$ (400 ns)	$2^2 \times 1/f_x$ (800 ns)
0	1	1	1	$2^2 \times 1/f_x$ (800 ns)	$2^3 \times 1/f_x$ (1.6 μ s)	$2^{10} \times 1/f_x$ (204.8 μ s)	$2^{11} \times 1/f_x$ (409.6 μ s)	$2^2 \times 1/f_x$ (800 ns)	$2^3 \times 1/f_x$ (1.6 μ s)
1	0	0	0	$2^3 \times 1/f_x$ (1.6 μ s)	$2^4 \times 1/f_x$ (3.2 μ s)	$2^{11} \times 1/f_x$ (409.6 μ s)	$2^{12} \times 1/f_x$ (819.2 μ s)	$2^3 \times 1/f_x$ (1.6 μ s)	$2^4 \times 1/f_x$ (3.2 μ s)
1	0	0	1	$2^4 \times 1/f_x$ (3.2 μ s)	$2^5 \times 1/f_x$ (6.4 μ s)	$2^{12} \times 1/f_x$ (819.2 μ s)	$2^{13} \times 1/f_x$ (1.64 ms)	$2^4 \times 1/f_x$ (3.2 μ s)	$2^5 \times 1/f_x$ (6.4 μ s)
1	0	1	0	$2^5 \times 1/f_x$ (6.4 μ s)	$2^6 \times 1/f_x$ (12.8 μ s)	$2^{13} \times 1/f_x$ (1.64 ms)	$2^{14} \times 1/f_x$ (3.28 ms)	$2^5 \times 1/f_x$ (6.4 μ s)	$2^6 \times 1/f_x$ (12.8 μ s)
1	0	1	1	$2^6 \times 1/f_x$ (12.8 μ s)	$2^7 \times 1/f_x$ (25.6 μ s)	$2^{14} \times 1/f_x$ (3.28 ms)	$2^{15} \times 1/f_x$ (6.55 ms)	$2^6 \times 1/f_x$ (12.8 μ s)	$2^7 \times 1/f_x$ (25.6 μ s)
1	1	0	0	$2^7 \times 1/f_x$ (25.6 μ s)	$2^8 \times 1/f_x$ (51.2 μ s)	$2^{15} \times 1/f_x$ (6.55 ms)	$2^{16} \times 1/f_x$ (13.1 ms)	$2^7 \times 1/f_x$ (25.6 μ s)	$2^8 \times 1/f_x$ (51.2 μ s)
1	1	0	1	$2^8 \times 1/f_x$ (51.2 μ s)	$2^9 \times 1/f_x$ (102.4 μ s)	$2^{16} \times 1/f_x$ (13.1 ms)	$2^{17} \times 1/f_x$ (26.2 ms)	$2^8 \times 1/f_x$ (51.2 μ s)	$2^9 \times 1/f_x$ (102.4 μ s)
1	1	1	0	$2^9 \times 1/f_x$ (102.4 μ s)	$2^{10} \times 1/f_x$ (204.8 μ s)	$2^{17} \times 1/f_x$ (26.2 ms)	$2^{18} \times 1/f_x$ (52.4 ms)	$2^9 \times 1/f_x$ (102.4 μ s)	$2^{10} \times 1/f_x$ (204.8 μ s)
1	1	1	1	$2^{11} \times 1/f_x$ (409.6 μ s)	$2^{12} \times 1/f_x$ (819.2 μ s)	$2^{19} \times 1/f_x$ (104.9 ms)	$2^{20} \times 1/f_x$ (209.7 ms)	$2^{11} \times 1/f_x$ (409.6 μ s)	$2^{12} \times 1/f_x$ (819.2 μ s)
Other than above				Setting prohibited					

- Remarks**
1. f_x : Main system clock oscillation frequency
 2. MCS : Oscillation mode selection register bit 0
 3. Values in parentheses when operated at $f_x = 5.0$ MHz.

Table 9-7. 8-Bit Timer/Event Counter 2 Interval Time

TCL17	TCL16	TCL15	TCL14	Minimum Interval Time		Maximum Interval Time		Resolution	
				MCS = 1	MCS = 0	MCS = 1	MCS = 0	MCS = 1	MCS = 0
0	0	0	0	T12 input cycle		$2^8 \times$ T12 input cycle		T12 input edge cycle	
0	0	0	1	T12 input cycle		$2^8 \times$ T12 input cycle		T12 input edge cycle	
0	1	1	0	$2 \times 1/f_x$ (400 ns)	$2^2 \times 1/f_x$ (800 ns)	$2^9 \times 1/f_x$ (102.4 μ s)	$2^{10} \times 1/f_x$ (204.8 μ s)	$2 \times 1/f_x$ (400 ns)	$2^2 \times 1/f_x$ (800 ns)
0	1	1	1	$2^2 \times 1/f_x$ (800 ns)	$2^3 \times 1/f_x$ (1.6 μ s)	$2^{10} \times 1/f_x$ (204.8 μ s)	$2^{11} \times 1/f_x$ (409.6 μ s)	$2^2 \times 1/f_x$ (800 ns)	$2^3 \times 1/f_x$ (1.6 μ s)
1	0	0	0	$2^3 \times 1/f_x$ (1.6 μ s)	$2^4 \times 1/f_x$ (3.2 μ s)	$2^{11} \times 1/f_x$ (409.6 μ s)	$2^{12} \times 1/f_x$ (819.2 μ s)	$2^3 \times 1/f_x$ (1.6 μ s)	$2^4 \times 1/f_x$ (3.2 μ s)
1	0	0	1	$2^4 \times 1/f_x$ (3.2 μ s)	$2^5 \times 1/f_x$ (6.4 μ s)	$2^{12} \times 1/f_x$ (819.2 μ s)	$2^{13} \times 1/f_x$ (1.64 ms)	$2^4 \times 1/f_x$ (3.2 μ s)	$2^5 \times 1/f_x$ (6.4 μ s)
1	0	1	0	$2^5 \times 1/f_x$ (6.4 μ s)	$2^6 \times 1/f_x$ (12.8 μ s)	$2^{13} \times 1/f_x$ (1.64 ms)	$2^{14} \times 1/f_x$ (3.28 ms)	$2^5 \times 1/f_x$ (6.4 μ s)	$2^6 \times 1/f_x$ (12.8 μ s)
1	0	1	1	$2^6 \times 1/f_x$ (12.8 μ s)	$2^7 \times 1/f_x$ (25.6 μ s)	$2^{14} \times 1/f_x$ (3.28 ms)	$2^{15} \times 1/f_x$ (6.55 ms)	$2^6 \times 1/f_x$ (12.8 μ s)	$2^7 \times 1/f_x$ (25.6 μ s)
1	1	0	0	$2^7 \times 1/f_x$ (25.6 μ s)	$2^8 \times 1/f_x$ (51.2 μ s)	$2^{15} \times 1/f_x$ (6.55 ms)	$2^{16} \times 1/f_x$ (13.1 ms)	$2^7 \times 1/f_x$ (25.6 μ s)	$2^8 \times 1/f_x$ (51.2 μ s)
1	1	0	1	$2^8 \times 1/f_x$ (51.2 μ s)	$2^9 \times 1/f_x$ (102.4 μ s)	$2^{16} \times 1/f_x$ (13.1 ms)	$2^{17} \times 1/f_x$ (26.2 ms)	$2^8 \times 1/f_x$ (51.2 μ s)	$2^9 \times 1/f_x$ (102.4 μ s)
1	1	1	0	$2^9 \times 1/f_x$ (102.4 μ s)	$2^{10} \times 1/f_x$ (204.8 μ s)	$2^{17} \times 1/f_x$ (26.2 ms)	$2^{18} \times 1/f_x$ (52.4 ms)	$2^9 \times 1/f_x$ (102.4 μ s)	$2^{10} \times 1/f_x$ (204.8 μ s)
1	1	1	1	$2^{11} \times 1/f_x$ (409.6 μ s)	$2^{12} \times 1/f_x$ (819.2 μ s)	$2^{19} \times 1/f_x$ (104.9 ms)	$2^{20} \times 1/f_x$ (209.7 ms)	$2^{11} \times 1/f_x$ (409.6 μ s)	$2^{12} \times 1/f_x$ (819.2 μ s)
Other than above				Setting prohibited					

- Remarks**
1. f_x : Main system clock oscillation frequency
 2. MCS : Oscillation mode selection register bit 0
 3. Values in parentheses when operated at $f_x = 5.0$ MHz

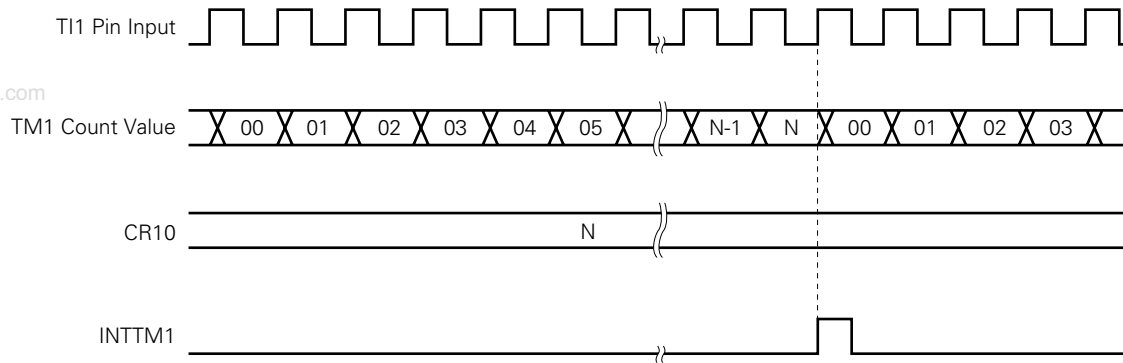
(2) External event counter operation

The external event counter counts the number of external clock pulses to be input to the T11/P33 and T12/P34 pins with 8-bit timer registers 1 and 2 (TM1 and TM2).

TM1 and TM2 are incremented each time the valid edge specified with the timer clock select register (TCL1) is input. Either the rising or falling edge can be selected.

When the TM1 and TM2 counted values match the values of 8-bit compare registers (CR10 and CR20), TM1 and TM2 are cleared to 0 and the interrupt request signals (INTTM1 and INTTM2) are generated.

Figure 9-9. External Event Counter Operation Timings (with Rising Edge Specified)



Remark N = 00H to FFH

(3) Square-wave output

A square wave with any selected frequency is output at intervals of the value preset to 8-bit compare registers 10 and 20 (CR10 and CR20).

The TO1/P31 or TO2/P32 pin output status is reversed at intervals of the count value preset to CR10 or CR20 by setting bit 0 (TOE1) or bit 4 (TOE2) of the 8-bit timer output control register (TOC1) to 1. This enables a square wave with any selected frequency to be output.

Table 9-8. 8-Bit Timer/Event Counters 1 and 2 Square-Wave Output Ranges

Minimum Pulse Width		Maximum Pulse Width		Resolution	
MCS = 1	MCS = 0	MCS = 1	MCS = 0	MCS = 1	MCS = 0
$2 \times 1/f_x$ (400 ns)	$2^2 \times 1/f_x$ (800 ns)	$2^9 \times 1/f_x$ (102.4 μ s)	$2^{10} \times 1/f_x$ (204.8 μ s)	$2 \times 1/f_x$ (400 ns)	$2^2 \times 1/f_x$ (800 ns)
$2^2 \times 1/f_x$ (800 ns)	$2^3 \times 1/f_x$ (1.6 μ s)	$2^{10} \times 1/f_x$ (204.8 μ s)	$2^{11} \times 1/f_x$ (409.6 μ s)	$2^2 \times 1/f_x$ (800 ns)	$2^3 \times 1/f_x$ (1.6 μ s)
$2^3 \times 1/f_x$ (1.6 μ s)	$2^4 \times 1/f_x$ (3.2 μ s)	$2^{11} \times 1/f_x$ (409.6 μ s)	$2^{12} \times 1/f_x$ (819.2 μ s)	$2^3 \times 1/f_x$ (1.6 μ s)	$2^4 \times 1/f_x$ (3.2 μ s)
$2^4 \times 1/f_x$ (3.2 μ s)	$2^5 \times 1/f_x$ (6.4 μ s)	$2^{12} \times 1/f_x$ (819.2 μ s)	$2^{13} \times 1/f_x$ (1.64 ms)	$2^4 \times 1/f_x$ (3.2 μ s)	$2^5 \times 1/f_x$ (6.4 μ s)
$2^5 \times 1/f_x$ (6.4 μ s)	$2^6 \times 1/f_x$ (12.8 μ s)	$2^{13} \times 1/f_x$ (1.64 ms)	$2^{14} \times 1/f_x$ (3.28 ms)	$2^5 \times 1/f_x$ (6.4 μ s)	$2^6 \times 1/f_x$ (12.8 μ s)
$2^6 \times 1/f_x$ (12.8 μ s)	$2^7 \times 1/f_x$ (25.6 μ s)	$2^{14} \times 1/f_x$ (3.28 ms)	$2^{15} \times 1/f_x$ (6.55 ms)	$2^6 \times 1/f_x$ (12.8 μ s)	$2^7 \times 1/f_x$ (25.6 μ s)
$2^7 \times 1/f_x$ (25.6 μ s)	$2^8 \times 1/f_x$ (51.2 μ s)	$2^{15} \times 1/f_x$ (6.55 ms)	$2^{16} \times 1/f_x$ (13.1 ms)	$2^7 \times 1/f_x$ (25.6 μ s)	$2^8 \times 1/f_x$ (51.2 μ s)
$2^8 \times 1/f_x$ (51.2 μ s)	$2^9 \times 1/f_x$ (102.4 μ s)	$2^{16} \times 1/f_x$ (13.1 ms)	$2^{17} \times 1/f_x$ (26.2 ms)	$2^8 \times 1/f_x$ (51.2 μ s)	$2^9 \times 1/f_x$ (102.4 μ s)
$2^9 \times 1/f_x$ (102.4 μ s)	$2^{10} \times 1/f_x$ (204.8 μ s)	$2^{17} \times 1/f_x$ (26.2 ms)	$2^{18} \times 1/f_x$ (52.4 ms)	$2^9 \times 1/f_x$ (102.4 μ s)	$2^{10} \times 1/f_x$ (204.8 μ s)
$2^{11} \times 1/f_x$ (409.6 μ s)	$2^{12} \times 1/f_x$ (819.2 μ s)	$2^{19} \times 1/f_x$ (104.9 ms)	$2^{20} \times 1/f_x$ (209.7 ms)	$2^{11} \times 1/f_x$ (409.6 μ s)	$2^{12} \times 1/f_x$ (819.2 μ s)

- Remarks**
1. f_x : Main system clock oscillation frequency
 2. MCS : Oscillation mode selection register bit 0
 3. Values in parentheses when operated at $f_x = 5.0$ MHz.

9.4.2 16-bit timer/event counter mode

When bit 2 (TMC12) of 8-bit timer mode control register 1 (TMC1) is set to 1 and the 16-bit timer/counter mode is selected, the overflow signal of 8-bit timer/event counter 1 (TM1) becomes a count clock of 8-bit timer/event counter 2 (TM2).

When a 2-channel 8-bit timer/event counter is used in the 16-bit timer/event counter mode, the count clock is selected with bits 0 to 3 (TCL10 to TCL13) of TCL1. Count operation enable/disable is selected with bit 0 (TCE1) of TMC1.

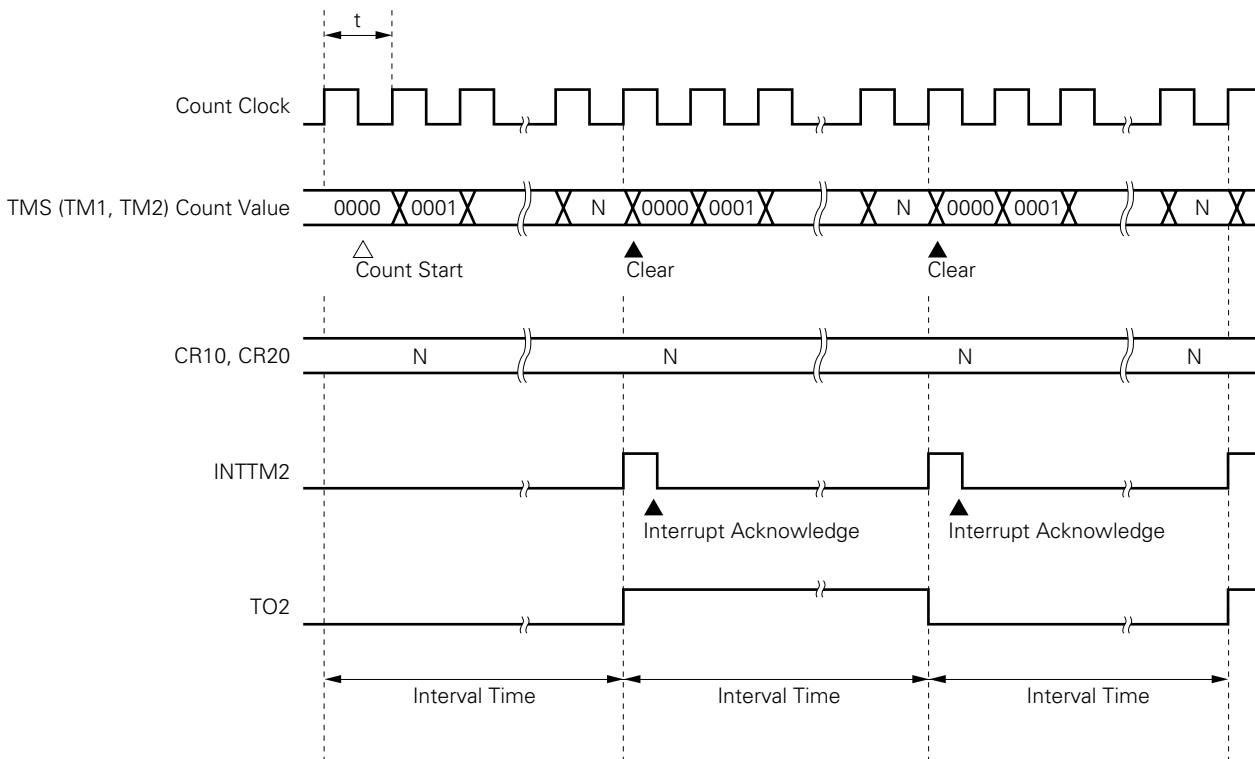
(1) Interval timer

The 8-bit timer/event counter operates as interval timer which generates interrupts repeatedly at intervals of the count value preset to 2-channel 8-bit compare registers 10 and 20 (CR10 and CR20).

When the 8-bit timer register 1 (TM1) and CR10 values match and the 8-bit timer register 2 (TM2) and CR20 values match, counting continues with the TM1 and TM2 values cleared to 0 and the interrupt request signal (INTTM2) is generated.

Count clock can be selected with bits 0 to 3 (TCL10 to TCL13) of the timer clock select register 1 (TCL1).

Figure 9-10. Interval Timer Operation Timing



Remark Interval time = $(N + 1) \times t$: N = 0000H to FFFFH

Caution Even if the 16-bit timer/event counter mode is used, when the TM1 count value matches the CR10 value, interrupt request (INTTM1) is generated and the F/F of 8-bit timer/event counter output control circuit 1 is inverted. Thus, when using 8-bit timer/event counter as 16-bit interval timer, set the INTTM1 mask flag TMMK1 to 1 to disable INTTM1 acknowledgment.

When reading the 16-bit timer (TMS) count value, use the 16-bit memory manipulation instruction.

Table 9-9. Interval Times when 2-Channel 8-Bit Timer/Event Counters (TM1 and TM2) are Used as 16-Bit Timer/Event Counter

TCL13	TCL12	TCL11	TCL10	Minimum Interval Time		Maximum Interval Time		Resolution	
				MCS = 1	MCS = 0	MCS = 1	MCS = 0	MCS = 1	MCS = 0
0	0	0	0	T11 input cycle		$2^8 \times$ T11 input cycle		T11 input edge cycle	
0	0	0	1	T11 input cycle		$2^8 \times$ T11 input cycle		T11 input edge cycle	
0	1	1	0	$2 \times 1/f_x$ (400 ns)	$2^2 \times 1/f_x$ (800 ns)	$2^{17} \times 1/f_x$ (26.2 ms)	$2^{18} \times 1/f_x$ (52.4 ms)	$2 \times 1/f_x$ (400 ns)	$2^2 \times 1/f_x$ (800 ns)
0	1	1	1	$2^2 \times 1/f_x$ (800 ns)	$2^3 \times 1/f_x$ (1.6 μ s)	$2^{18} \times 1/f_x$ (52.4 ms)	$2^{19} \times 1/f_x$ (104.9 ms)	$2^2 \times 1/f_x$ (800 ns)	$2^3 \times 1/f_x$ (1.6 μ s)
1	0	0	0	$2^3 \times 1/f_x$ (1.6 μ s)	$2^4 \times 1/f_x$ (3.2 μ s)	$2^{19} \times 1/f_x$ (104.9 ms)	$2^{20} \times 1/f_x$ (209.7 ms)	$2^3 \times 1/f_x$ (1.6 μ s)	$2^4 \times 1/f_x$ (3.2 μ s)
1	0	0	1	$2^4 \times 1/f_x$ (3.2 μ s)	$2^5 \times 1/f_x$ (6.4 μ s)	$2^{20} \times 1/f_x$ (209.7 ms)	$2^{21} \times 1/f_x$ (419.4 ms)	$2^4 \times 1/f_x$ (3.2 μ s)	$2^5 \times 1/f_x$ (6.4 μ s)
1	0	1	0	$2^5 \times 1/f_x$ (6.4 μ s)	$2^6 \times 1/f_x$ (12.8 μ s)	$2^{21} \times 1/f_x$ (419.4 ms)	$2^{22} \times 1/f_x$ (838.9 ms)	$2^5 \times 1/f_x$ (6.4 μ s)	$2^6 \times 1/f_x$ (12.8 μ s)
1	0	1	1	$2^6 \times 1/f_x$ (12.8 μ s)	$2^7 \times 1/f_x$ (25.6 μ s)	$2^{22} \times 1/f_x$ (838.9 ms)	$2^{23} \times 1/f_x$ (1.7 s)	$2^6 \times 1/f_x$ (12.8 μ s)	$2^7 \times 1/f_x$ (25.6 μ s)
1	1	0	0	$2^7 \times 1/f_x$ (25.6 μ s)	$2^8 \times 1/f_x$ (51.2 μ s)	$2^{23} \times 1/f_x$ (1.7 s)	$2^{24} \times 1/f_x$ (3.4 s)	$2^7 \times 1/f_x$ (25.6 μ s)	$2^8 \times 1/f_x$ (51.2 μ s)
1	1	0	1	$2^8 \times 1/f_x$ (51.2 μ s)	$2^9 \times 1/f_x$ (102.4 μ s)	$2^{24} \times 1/f_x$ (3.4 s)	$2^{25} \times 1/f_x$ (6.7 s)	$2^8 \times 1/f_x$ (51.2 μ s)	$2^9 \times 1/f_x$ (102.4 μ s)
1	1	1	0	$2^9 \times 1/f_x$ (102.4 μ s)	$2^{10} \times 1/f_x$ (204.8 μ s)	$2^{25} \times 1/f_x$ (6.7 s)	$2^{26} \times 1/f_x$ (13.4 s)	$2^9 \times 1/f_x$ (102.4 μ s)	$2^{10} \times 1/f_x$ (204.8 μ s)
1	1	1	1	$2^{11} \times 1/f_x$ (409.6 μ s)	$2^{12} \times 1/f_x$ (819.2 μ s)	$2^{27} \times 1/f_x$ (26.8 s)	$2^{28} \times 1/f_x$ (53.7 s)	$2^{11} \times 1/f_x$ (409.6 μ s)	$2^{12} \times 1/f_x$ (819.2 μ s)
Other than above				Setting prohibited					

- Remarks**
1. f_x : Main system clock oscillation frequency
 2. MCS : Oscillation mode selection register bit 0
 3. Values in parentheses when operated at $f_x = 5.0$ MHz.

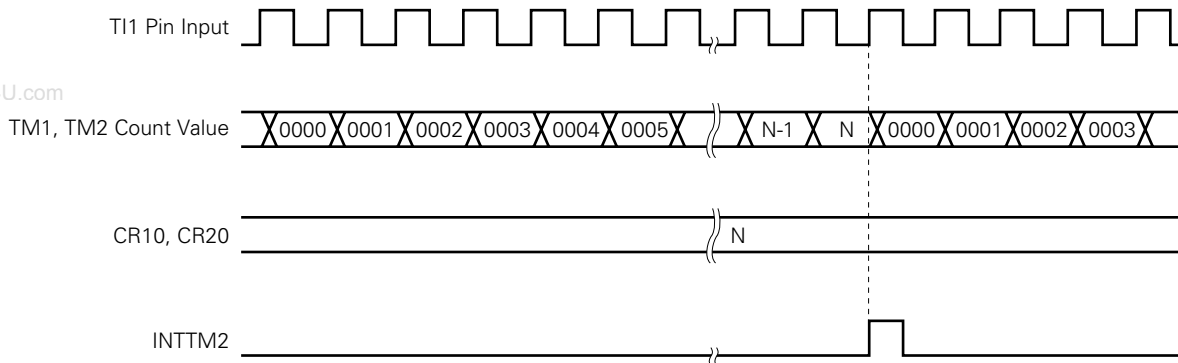
(2) External event counter operations

The external event counter counts the number of external clock pulses to be input to the TI1/P33 pin with 2-channel 8-bit timer registers 1 and 2 (TM1 and TM2).

TM1 and TM2 are incremented each time the valid edge specified with the timer clock select register 1 (TCL1) is input. Either the rising or falling edge can be selected.

When the TM1 and TM2 counted values match the values of 8-bit compare registers 10 and 20 (CR10 and CR20), TM1 and TM2 are cleared to 0 and the interrupt request signal (INTTM2) is generated.

Figure 9-11. External Event Counter Operation Timings (with Rising Edge Specified)



Caution Even if the 16-bit timer/event counter mode is used, when the TM1 count value matches the CR10 value, interrupt request (INTTM1) is generated and the F/F of 8-bit timer/event counter output control circuit 1 is inverted. Thus, when using 8-bit timer/event counter as 16-bit interval timer, set the INTTM1 mask flag TMMK1 to 1 to disable INTTM1 acknowledgment.

When reading the 16-bit timer (TMS) count value, use the 16-bit memory manipulation instruction.

(3) Square-wave output operation

A square wave with any selected frequency is output at intervals of the value preset to 8-bit compare registers 10 and 20 (CR10 and CR20).

The TO2/P32 pin output status is reversed at intervals of the count value preset to CR10 and CR20 by setting bit 4 (TOE2) of the 8-bit timer output control register (TOC1) to 1. This enables a square wave with any selected frequency to be output.

Table 9-10. Square-Wave Output Ranges when 2-Channel 8-Bit Timer/Event Counters (TM1 and TM2) are Used as 16-Bit Timer/Event Counter

Minimum Pulse Width		Maximum Pulse Width		Resolution	
MCS = 1	MCS = 0	MCS = 1	MCS = 0	MCS = 1	MCS = 0
$2 \times 1/f_x$ (400 ns)	$2^2 \times 1/f_x$ (800 ns)	$2^{17} \times 1/f_x$ (26.2 ms)	$2^{18} \times 1/f_x$ (52.4 ms)	$2 \times 1/f_x$ (400 ns)	$2^2 \times 1/f_x$ (800 ns)
$2^2 \times 1/f_x$ (800 ns)	$2^3 \times 1/f_x$ (1.6 μ s)	$2^{18} \times 1/f_x$ (52.4 ms)	$2^{19} \times 1/f_x$ (104.9 ms)	$2^2 \times 1/f_x$ (800 ns)	$2^3 \times 1/f_x$ (1.6 μ s)
$2^3 \times 1/f_x$ (1.6 μ s)	$2^4 \times 1/f_x$ (3.2 μ s)	$2^{19} \times 1/f_x$ (104.9 ms)	$2^{20} \times 1/f_x$ (209.7 ms)	$2^3 \times 1/f_x$ (1.6 μ s)	$2^4 \times 1/f_x$ (3.2 μ s)
$2^4 \times 1/f_x$ (3.2 μ s)	$2^5 \times 1/f_x$ (6.4 μ s)	$2^{20} \times 1/f_x$ (209.7 ms)	$2^{21} \times 1/f_x$ (419.4 ms)	$2^4 \times 1/f_x$ (3.2 μ s)	$2^5 \times 1/f_x$ (6.4 μ s)
$2^5 \times 1/f_x$ (6.4 μ s)	$2^6 \times 1/f_x$ (12.8 μ s)	$2^{21} \times 1/f_x$ (419.4 ms)	$2^{22} \times 1/f_x$ (838.9 ms)	$2^5 \times 1/f_x$ (6.4 μ s)	$2^6 \times 1/f_x$ (12.8 μ s)
$2^6 \times 1/f_x$ (12.8 μ s)	$2^7 \times 1/f_x$ (25.6 μ s)	$2^{22} \times 1/f_x$ (838.9 ms)	$2^{23} \times 1/f_x$ (1.7 s)	$2^6 \times 1/f_x$ (12.8 μ s)	$2^7 \times 1/f_x$ (25.6 μ s)
$2^7 \times 1/f_x$ (25.6 μ s)	$2^8 \times 1/f_x$ (51.2 μ s)	$2^{23} \times 1/f_x$ (1.7 s)	$2^{24} \times 1/f_x$ (3.4 s)	$2^7 \times 1/f_x$ (25.6 μ s)	$2^8 \times 1/f_x$ (51.2 μ s)
$2^8 \times 1/f_x$ (51.2 μ s)	$2^9 \times 1/f_x$ (102.4 μ s)	$2^{24} \times 1/f_x$ (3.4 s)	$2^{25} \times 1/f_x$ (6.7 s)	$2^8 \times 1/f_x$ (51.2 μ s)	$2^9 \times 1/f_x$ (102.4 μ s)
$2^9 \times 1/f_x$ (102.4 μ s)	$2^{10} \times 1/f_x$ (204.8 μ s)	$2^{25} \times 1/f_x$ (6.7 s)	$2^{26} \times 1/f_x$ (13.4 s)	$2^9 \times 1/f_x$ (102.4 μ s)	$2^{10} \times 1/f_x$ (204.8 μ s)
$2^{11} \times 1/f_x$ (409.6 μ s)	$2^{12} \times 1/f_x$ (819.2 μ s)	$2^{27} \times 1/f_x$ (26.8 s)	$2^{28} \times 1/f_x$ (53.7 s)	$2^{11} \times 1/f_x$ (409.6 μ s)	$2^{12} \times 1/f_x$ (819.2 μ s)

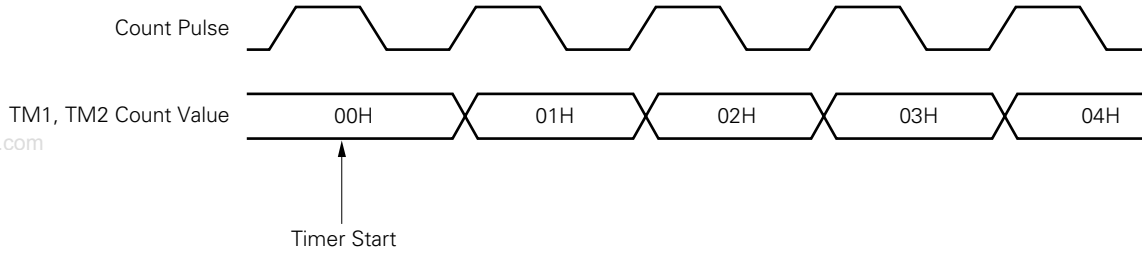
- Remarks**
1. f_x : Main system clock oscillation frequency
 2. MCS : Oscillation mode selection register bit 0
 3. Values in parentheses when operated at $f_x = 5.0$ MHz.

9.5 Cautions on 8-Bit Timer/Event Counters 1 and 2

(1) Timer start errors

An error with a maximum of one clock may occur concerning the time required for a match signal to be generated after timer start. This is because 8-bit timer registers 1 and 2 (TM1 and TM2) are started asynchronously with the count pulse.

Figure 9-12. 8-Bit Timer Registers 1 and 2 Start Timing



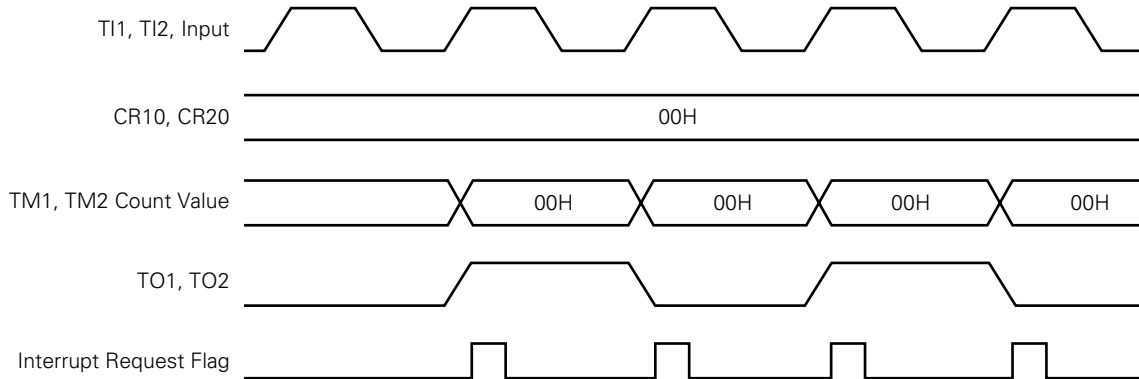
(2) 8-bit compare register 10 and 20 setting

The 8-bit compare registers 10 and 20 (CR10 and CR20) can be set to 00H.

Thus, when these 8-bit compare registers are used as event counters, one-pulse count operation can be carried out.

When the 8-bit compare register is used as 16-bit timer/event counter, write data to CR10 and CR20 after setting bit 0 (TCE1) of the 8-bit timer mode control register 1 to 0 and stopping timer operation.

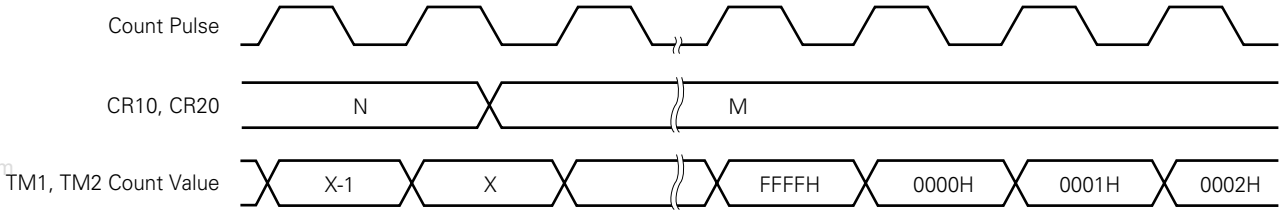
Figure 9-13. External Event Counter Operation Timing



(3) Operation after compare register change during timer count operation

If the values after the 8-bit compare registers 10 and 20 (CR10 and CR20) are changed are smaller than those of 8-bit timer registers 1 and 2 (TM1 and TM2), TM1 and TM2 continue counting, overflow and then restart counting from 0. Thus, if the value (M) after CR10 and CR20 change is smaller than value (N) before the change, it is necessary to restart the timer after changing CR10 and CR20.

Figure 9-14. Timing after Compare Register Change during Timer Count Operation



Remark $N > X > M$

[MEMO]

www.DataSheet4U.com

CHAPTER 10 WATCH TIMER

10.1 Watch Timer Functions

The watch timer has the following functions.

- Watch timer
- Interval timer

The watch timer and the interval timer can be used simultaneously.

www.DataSheet4U.com

(1) Watch timer

When the 32.768 kHz subsystem clock is used, a flag (WTIF) is set at 0.5 second or 0.25 second intervals. When the 4.19 MHz (standard: 4.194304 MHz) main system clock is used, a flag (WTIF) is set at 0.5 second or 0.25 second intervals.

Caution 0.5-second intervals cannot be generated with the 5.0-MHz main system clock. You should switch to the 32.768 kHz subsystem clock to generate 0.5-second intervals.

(2) Interval timer

Interrupt requests (INTTM3) are generated at the preset time interval.

Table 10-1. Interval Timer Interval Time

Interval Time	When operated at $f_{xx} = 5.0 \text{ MHz}$	When operated at $f_{xx} = 4.19 \text{ MHz}$	When operated at $f_{xT} = 32.768 \text{ kHz}$
$2^4 \times 1/f_w$	410 μs	488 μs	488 μs
$2^5 \times 1/f_w$	819 μs	977 μs	977 μs
$2^6 \times 1/f_w$	1.64 ms	1.95 ms	1.95 ms
$2^7 \times 1/f_w$	3.28 ms	3.91 ms	3.91 ms
$2^8 \times 1/f_w$	6.55 ms	7.81 ms	7.81 ms
$2^9 \times 1/f_w$	13.1 ms	15.6 ms	15.6 ms

Remark

- f_{xx} : Main system clock frequency (f_x or $f_x/2$)
- f_x : Main system clock oscillation frequency
- f_{xT} : Subsystem clock oscillation frequency
- f_w : Watch timer clock frequency ($f_{xx}/2^7$ or f_{xT})

10.2 Watch Timer Configuration

The watch timer consists of the following hardware.

Table 10-2. Watch Timer Configuration

Item	Configuration
Counter	5 bits × 1
Control register	Timer clock select register 2 (TCL2) Watch timer mode control register (TMC2)

10.3 Watch Timer Control Registers

The following two types of registers are used to control the watch timer.

- Timer clock select register 2 (TCL2)
- Watch timer mode control register (TMC2)

(1) Timer clock select register 2 (TCL2)

This register sets the watch timer count clock.

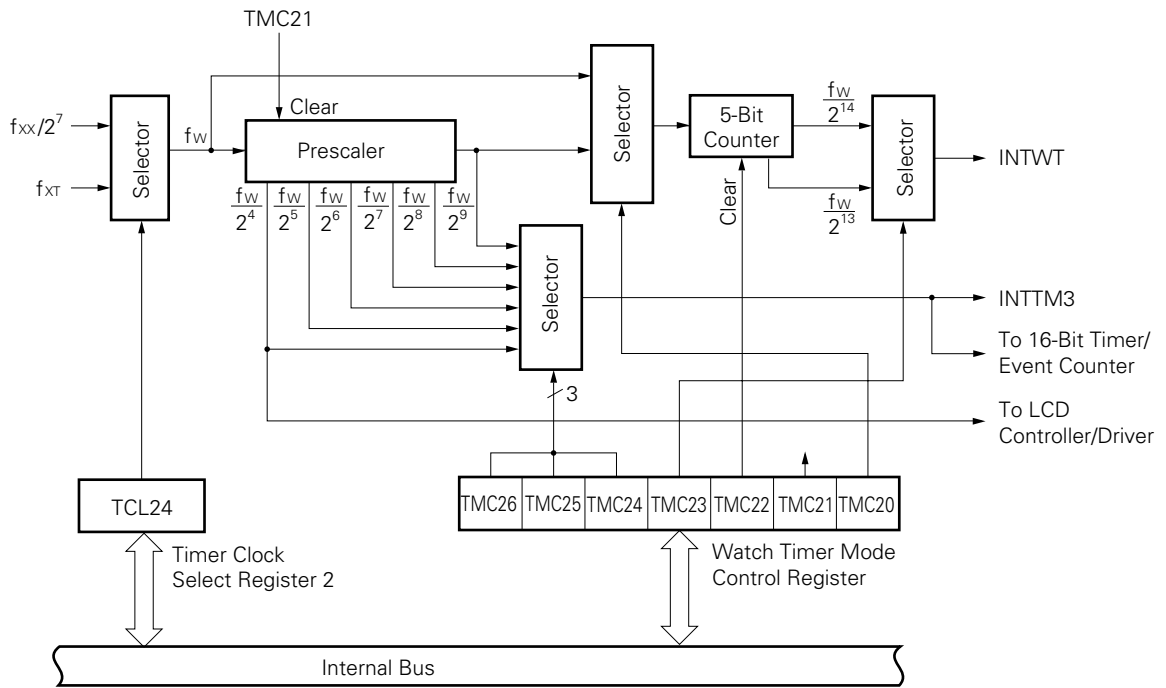
TCL2 is set with an 8-bit memory manipulation instruction.

$\overline{\text{RESET}}$ input sets TCL2 to 00H.

Remark Besides setting the watch timer count clock, TCL2 sets the watchdog timer count clock and buzzer output frequency.

Figure 10-1. Watch Timer Block Diagram

*



www.DataSheet4U.com

Figure 10-2. Timer Clock Select Register 2 Format

Symbol	7	6	5	4	3	2	1	0	Address	After Reset	R/W
TCL2	TCL27	TCL26	TCL25	TCL24	0	TCL22	TCL21	TCL20	FF42H	00H	R/W

TCL22	TCL21	TCL20	Watchdog Timer Count Clock Selection		
				MCS=1	MCS=0
0	0	0	$f_{xx}/2^3$	$f_x/2^3$ (625 kHz)	$f_x/2^4$ (313 kHz)
0	0	1	$f_{xx}/2^4$	$f_x/2^4$ (313 kHz)	$f_x/2^5$ (156 kHz)
0	1	0	$f_{xx}/2^5$	$f_x/2^5$ (156 kHz)	$f_x/2^6$ (78.1 kHz)
0	1	1	$f_{xx}/2^6$	$f_x/2^6$ (78.1 kHz)	$f_x/2^7$ (39.1 kHz)
1	0	0	$f_{xx}/2^7$	$f_x/2^7$ (39.1 kHz)	$f_x/2^8$ (19.5 kHz)
1	0	1	$f_{xx}/2^8$	$f_x/2^8$ (19.5 kHz)	$f_x/2^9$ (9.8 kHz)
1	1	0	$f_{xx}/2^9$	$f_x/2^9$ (9.8 kHz)	$f_x/2^{10}$ (4.9 kHz)
1	1	1	$f_{xx}/2^{11}$	$f_x/2^{11}$ (2.4 kHz)	$f_x/2^{12}$ (1.2 kHz)

TCL24	Watch Timer Count Clock Selection		
		MCS=1	MCS=0
0	$f_{xx}/2^7$	$f_x/2^7$ (39.1 kHz)	$f_x/2^8$ (19.5 kHz)
1	f_{XT} (32.768 kHz)		

TCL27	TCL26	TCL25	Buzzer Output Frequency Selection		
				MCS=1	MCS=0
0	x	x	Buzzer output disable		
1	0	0	$f_{xx}/2^9$	$f_x/2^9$ (9.8 kHz)	$f_x/2^{10}$ (4.9 kHz)
1	0	1	$f_{xx}/2^{10}$	$f_x/2^{10}$ (4.9 kHz)	$f_x/2^{11}$ (2.4 kHz)
1	1	0	$f_{xx}/2^{11}$	$f_x/2^{11}$ (2.4 kHz)	$f_x/2^{12}$ (1.2 kHz)
1	1	1	Setting prohibited		

Caution When rewriting TCL2 to other data, stop the timer operation beforehand.

- Remarks**
1. f_{xx} : Main system clock frequency (f_x or $f_x/2$)
 2. f_x : Main system clock oscillation frequency
 3. f_{XT} : Subsystem clock oscillation frequency
 4. x : Don't care
 5. MCS : Oscillation mode selection register bit 0
 6. Figures in parentheses apply to operation with $f_x = 5.0$ MHz or $f_{XT} = 32.768$ kHz.

(2) Watch timer mode control register (TMC2)

This register sets the watch timer operating mode, watch flag set time and prescaler interval time and enables/disables prescaler and 5-bit counter operations.

TMC2 is set with a 1-bit or 8-bit memory manipulation instruction.

RESET input sets TMC2 to 00H.

Figure 10-3. Watch Timer Mode Control Register Format

Symbol	7	6	5	4	3	2	1	0	Address	After Reset	R/W
TMC2	0	TMC26	TMC25	TMC24	TMC23	TMC22	TMC21	TMC20	FF4AH	00H	R/W

TMC20	Watch Operating Mode Selection		
0	Normal operating mode (flag set at $f_w/2^{14}$)		
1	Fast feed operating mode (flag set at $f_w/2^5$)		

TMC21	Prescaler Operation Control		
0	Clear after operation stop		
1	Operation enable		

TMC22	5-Bit Counter Operation Control		
0	Clear after operation stop		
1	Operation enable		

TMC23	Watch Flag Set Time Selection		
	$f_{xx} = 5.0$ MHz Operation	$f_{xx} = 4.19$ MHz Operation	$f_{xt} = 32.768$ kHz Operation
	0	$2^{14}/f_w$ (0.4 sec)	$2^{14}/f_w$ (0.5 sec)
1	$2^{13}/f_w$ (0.2 sec)	$2^{13}/f_w$ (0.25 sec)	$2^{13}/f_w$ (0.25 sec)

TMC26	TMC25	TMC24	Prescaler Interval Time Selection					
			$f_{xx} = 5.0$ MHz Operation	$f_{xx} = 4.19$ MHz Operation	$f_{xt} = 32.768$ kHz Operation			
			0	0	0	$2^4/f_w$ (410 μ s)	$2^4/f_w$ (488 μ s)	$2^4/f_w$ (488 μ s)
			0	0	1	$2^5/f_w$ (819 μ s)	$2^5/f_w$ (977 μ s)	$2^5/f_w$ (977 μ s)
			0	1	0	$2^6/f_w$ (1.64 ms)	$2^6/f_w$ (1.95 ms)	$2^6/f_w$ (1.95 ms)
			0	1	1	$2^7/f_w$ (3.28 ms)	$2^7/f_w$ (3.91 ms)	$2^7/f_w$ (3.91 ms)
			1	0	0	$2^8/f_w$ (6.55 ms)	$2^8/f_w$ (7.81 ms)	$2^8/f_w$ (7.81 ms)
			1	0	1	$2^9/f_w$ (13.1 ms)	$2^9/f_w$ (15.6 ms)	$2^9/f_w$ (15.6 ms)
Other than above			Setting prohibited					

Caution When the watch timer is used, the prescaler should not be cleared frequently.

Remark f_w : Watch timer clock frequency ($f_{xx}/2^7$ or f_{xt})
 f_{xx} : Main system clock frequency (f_x or $f_x/2$)
 f_x : Main system clock oscillation frequency
 f_{xt} : Subsystem clock oscillation frequency

10.4 Watch Timer Operations

10.4.1 Watch timer operation

When the 32.768-kHz subsystem clock or 4.19-MHz main system clock is used, the timer operates as a watch timer with a 0.5-second or 0.25-second interval.

The watch timer sets the test input flag (WTIF) to 1 at the constant time interval. The standby state (STOP mode/ HALT mode) can be cleared by setting WTIF to 1.

When bit 2 (TMC22) of the watch timer mode control register is set to 0, the 5-bit counter is cleared and the count operation stops.

For simultaneous operation of the interval timer, zero-second start can be achieved by setting TMC22 to 0 (maximum error: 26.2 ms when operated at $f_{xx} = 5.0$ MHz).

10.4.2 Interval timer operation

The watch timer operates as interval timer which generates interrupts repeatedly at an interval of the preset count value.

The interval time can be selected with bits 4 to 6 (TMC24 to TMC26) of the watch timer mode control register.

Table 10-3. Interval Timer Interval Time

TMC26	TMC25	TMC24	Interval Time	When operated at $f_{xx} = 5.0$ MHz	When operated at $f_{xx} = 4.19$ MHz	When operated at $f_{XT} = 32.768$ kHz
0	0	0	$2^4 \times 1/f_w$	410 μ s	488 μ s	488 μ s
0	0	1	$2^5 \times 1/f_w$	819 μ s	977 μ s	977 μ s
0	1	0	$2^6 \times 1/f_w$	1.64 ms	1.95 ms	1.95 ms
0	1	1	$2^7 \times 1/f_w$	3.28 ms	3.91 ms	3.91 ms
1	0	0	$2^8 \times 1/f_w$	6.55 ms	7.81 ms	7.81 ms
1	0	1	$2^9 \times 1/f_w$	13.1 ms	15.6 ms	15.6 ms
Other than above			Setting prohibited			

Remark f_{xx} : Main system clock frequency (f_x or $f_x/2$)
 f_x : Main system clock oscillation frequency
 f_{XT} : Subsystem clock oscillation frequency
 f_w : Watch timer clock frequency ($f_{xx}/2^7$ or f_{XT})

CHAPTER 11 WATCHDOG TIMER

11.1 Watchdog Timer Functions

The watchdog timer has the following functions.

- Watchdog timer
- Interval timer

Caution Select the watchdog timer mode or the interval timer mode with the watchdog timer mode register (WDTM).

www.DataSheet4U.com

(1) Watchdog timer mode

An inadvertent program loop is detected. Upon detection of the inadvertent program loop, a non-maskable interrupt or $\overline{\text{RESET}}$ can be generated.

Table 11-1. Watchdog Timer Inadvertent Program Overrun Detection Times

Runaway Detection Time	MCS = 1	MCS = 0
$2^{11} \times 1/f_{xx}$	$2^{11} \times 1/f_x$ (410 μs)	$2^{12} \times 1/f_x$ (819 μs)
$2^{12} \times 1/f_{xx}$	$2^{12} \times 1/f_x$ (819 μs)	$2^{13} \times 1/f_x$ (1.64 ms)
$2^{13} \times 1/f_{xx}$	$2^{13} \times 1/f_x$ (1.64 ms)	$2^{14} \times 1/f_x$ (3.28 ms)
$2^{14} \times 1/f_{xx}$	$2^{14} \times 1/f_x$ (3.28 ms)	$2^{15} \times 1/f_x$ (6.55 ms)
$2^{15} \times 1/f_{xx}$	$2^{15} \times 1/f_x$ (6.55 ms)	$2^{16} \times 1/f_x$ (13.1 ms)
$2^{16} \times 1/f_{xx}$	$2^{16} \times 1/f_x$ (13.1 ms)	$2^{17} \times 1/f_x$ (26.2 ms)
$2^{17} \times 1/f_{xx}$	$2^{17} \times 1/f_x$ (26.2 ms)	$2^{18} \times 1/f_x$ (52.4 ms)
$2^{19} \times 1/f_{xx}$	$2^{19} \times 1/f_x$ (104.9 ms)	$2^{20} \times 1/f_x$ (209.7 ms)

- Remarks**
1. f_{xx} : Main system clock frequency (f_x or $f_x/2$)
 2. f_x : Main system clock oscillation frequency
 3. MCS : Oscillation mode selection register bit 0
 4. Figures in parentheses apply to operation with $f_x = 5.0$ MHz.

(2) Interval timer mode

Interrupts are generated at the preset time intervals.

Table 11-2. Interval Times

Interval Time	MCS = 1	CS = 0
$2^{11} \times 1/f_{xx}$	$2^{11} \times 1/f_x$ (410 μ s)	$2^{12} \times 1/f_x$ (819 μ s)
$2^{12} \times 1/f_{xx}$	$2^{12} \times 1/f_x$ (819 μ s)	$2^{13} \times 1/f_x$ (1.64 ms)
$2^{13} \times 1/f_{xx}$	$2^{13} \times 1/f_x$ (1.64 ms)	$2^{14} \times 1/f_x$ (3.28 ms)
$2^{14} \times 1/f_{xx}$	$2^{14} \times 1/f_x$ (3.28 ms)	$2^{15} \times 1/f_x$ (6.55 ms)
$2^{15} \times 1/f_{xx}$	$2^{15} \times 1/f_x$ (6.55 ms)	$2^{16} \times 1/f_x$ (13.1 ms)
$2^{16} \times 1/f_{xx}$	$2^{16} \times 1/f_x$ (13.1 ms)	$2^{17} \times 1/f_x$ (26.2 ms)
$2^{17} \times 1/f_{xx}$	$2^{17} \times 1/f_x$ (26.2 ms)	$2^{18} \times 1/f_x$ (52.4 ms)
$2^{19} \times 1/f_{xx}$	$2^{19} \times 1/f_x$ (104.9 ms)	$2^{20} \times 1/f_x$ (209.7 ms)

- Remarks**
1. f_{xx} : Main system clock frequency (f_x or $f_x/2$)
 2. f_x : Main system clock oscillation frequency
 3. MCS : Oscillation mode selection register bit 0
 4. Figures in parentheses apply to operation with $f_x = 5.0$ MHz.

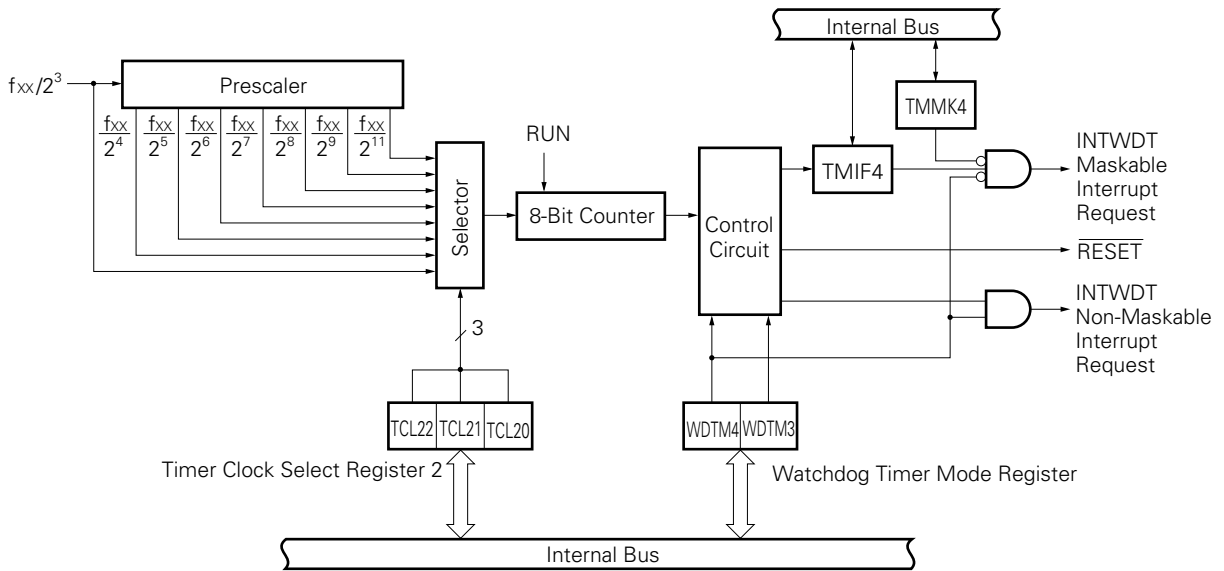
11.2 Watchdog Timer Configuration

The watchdog timer consists of the following hardware.

Table 11-3. Watchdog Timer Configuration

Item	Configuration
Control register	Timer clock select register 2 (TCL2) Watchdog timer mode register (WDTM)

Figure 11-1. Watchdog Timer Block Diagram



www.DataSheet4U.com

11.3 Watchdog Timer Control Registers

The following two types of registers are used to control the watchdog timer.

- Timer clock select register 2 (TCL2)
- Watchdog timer mode register (WDTM)

(1) Timer clock select register 2 (TCL2)

This register sets the watchdog timer count clock.

TCL2 is set with 8-bit memory manipulation instruction.

RESET input sets TCL2 to 00H.

www.DataSheet4U.com **Remark** Besides setting the watchdog timer count clock, TCL2 sets the watch timer count clock and buzzer output frequency.

Figure 11-2. Timer Clock Select Register 2 Format

Symbol	7	6	5	4	3	2	1	0	Address	After Reset	R/W
TCL2	TCL27	TCL26	TCL25	TCL24	0	TCL22	TCL21	TCL20	FF42H	00H	R/W

TCL22	TCL21	TCL20	Watchdog Timer Count Clock Selection		
				MCS=1	MCS=0
0	0	0	$f_{xx}/2^3$	$f_x/2^3$ (625 kHz)	$f_x/2^4$ (313 kHz)
0	0	1	$f_{xx}/2^4$	$f_x/2^4$ (313 kHz)	$f_x/2^5$ (156 kHz)
0	1	0	$f_{xx}/2^5$	$f_x/2^5$ (156 kHz)	$f_x/2^6$ (78.1 kHz)
0	1	1	$f_{xx}/2^6$	$f_x/2^6$ (78.1 kHz)	$f_x/2^7$ (39.1 kHz)
1	0	0	$f_{xx}/2^7$	$f_x/2^7$ (39.1 kHz)	$f_x/2^8$ (19.5 kHz)
1	0	1	$f_{xx}/2^8$	$f_x/2^8$ (19.5 kHz)	$f_x/2^9$ (9.8 kHz)
1	1	0	$f_{xx}/2^9$	$f_x/2^9$ (9.8 kHz)	$f_x/2^{10}$ (4.9 kHz)
1	1	1	$f_{xx}/2^{11}$	$f_x/2^{11}$ (2.4 kHz)	$f_x/2^{12}$ (1.2 kHz)

TCL24	Watch Timer Count Clock Selection		
		MCS=1	MCS=0
0	$f_{xx}/2^7$	$f_x/2^7$ (39.1 kHz)	$f_x/2^8$ (19.5 kHz)
1	f_{xt} (32.768 kHz)		

TCL27	TCL26	TCL25	Buzzer Output Frequency Selection		
				MCS=1	MCS=0
0	×	×	Buzzer output disable		
1	0	0	$f_{xx}/2^9$	$f_x/2^9$ (9.8 kHz)	$f_x/2^{10}$ (4.9 kHz)
1	0	1	$f_{xx}/2^{10}$	$f_x/2^{10}$ (4.9 kHz)	$f_x/2^{11}$ (2.4 kHz)
1	1	0	$f_{xx}/2^{11}$	$f_x/2^{11}$ (2.4 kHz)	$f_x/2^{12}$ (1.2 kHz)
1	1	1	Setting prohibited		

Caution When rewriting TCL2 to other data, stop the timer operation beforehand.

- Remarks**
1. f_{xx} : Main system clock frequency (f_x or $f_x/2$)
 2. f_x : Main system clock oscillation frequency
 3. f_{xt} : Subsystem clock oscillation frequency
 4. × : Don't care
 5. MCS : Oscillation mode selection register bit 0
 6. Figures in parentheses apply to operation with $f_x = 5.0$ MHz or $f_{xt} = 32.768$ kHz.

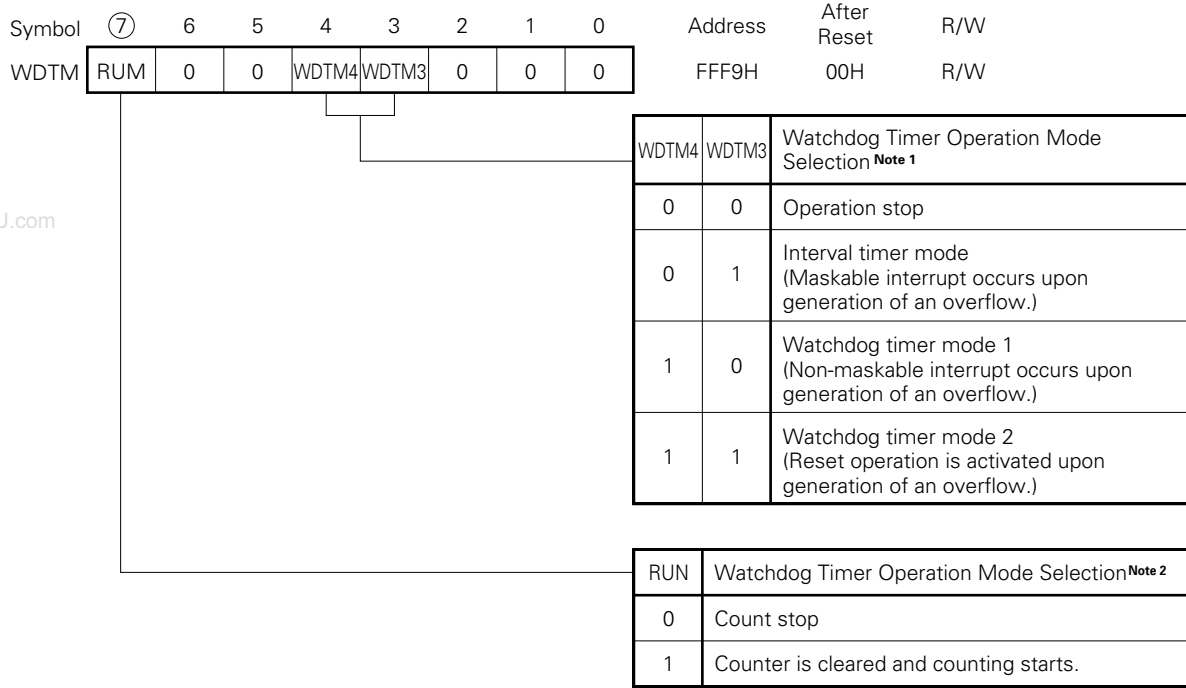
(2) Watchdog timer mode register (WDTM)

This register sets the watchdog timer operating mode and enables/disables counting.

WDTM is set with a 1-bit or 8-bit memory manipulation instruction.

$\overline{\text{RESET}}$ input sets WDTM to 00H.

Figure 11-3. Watchdog Timer Mode Register Format



Notes 1. Once set to 1, WDTM3 and WDTM4 cannot be cleared to 0 by software.

2. Once set to 1, RUM cannot be cleared to 0 by software.

Thus, once counting starts, it can only be stopped by $\overline{\text{RESET}}$ input.

Caution When 1 is set in RUN so that the watchdog timer is cleared, the actual overflow time is up to 0.5 % shorter than the time set by timer clock select register 2.

11.4 Watchdog Timer Operations

11.4.1 Watchdog timer operation

When bit 4 (WDTM4) of the watchdog timer mode register (WDTM) is set to 1, the watchdog timer is operated to detect any inadvertent program loop.

The watchdog timer count clock (inadvertent program loop detection time interval) can be selected with bits 0 to 2 (TCL20 to TCL22) of the timer clock select register 2 (TCL2).

Watchdog timer starts by setting bit 7 (RUN) of WDTM to 1. After the watchdog timer is started, set RUN to 1 within the set overrun time interval. The watchdog timer can be cleared and counting is started by setting RUN to 1. If RUN is not set to 1 and the inadvertent program loop detection time is past, system reset or a non-maskable interrupt is generated according to the WDTM bit 3 (WDTM3) value.

The watchdog timer continues operating in the HALT mode but it stops in the STOP mode. Thus, set RUN to 1 before the STOP mode is set, clear the watchdog timer and then execute the STOP instruction.

- Cautions**
1. The actual overrun detection time may be shorter than the set time by a maximum of 0.5 %.
 2. When the subsystem clock is selected for CPU clock, watchdog timer count operation is stopped.

Table 11-4. Watchdog Timer Overrun Detection Time

TCL22	TCL21	TCL20	Runaway Detection Time	MCS = 1	MCS = 0
0	0	0	$2^{11} \times 1/f_{xx}$	$2^{11} \times 1/f_x$ (410 μ s)	$2^{12} \times 1/f_x$ (819 μ s)
0	0	1	$2^{12} \times 1/f_{xx}$	$2^{12} \times 1/f_x$ (819 μ s)	$2^{13} \times 1/f_x$ (1.64 ms)
0	1	0	$2^{13} \times 1/f_{xx}$	$2^{13} \times 1/f_x$ (1.64 ms)	$2^{14} \times 1/f_x$ (3.28 ms)
0	1	1	$2^{14} \times 1/f_{xx}$	$2^{14} \times 1/f_x$ (3.28 ms)	$2^{15} \times 1/f_x$ (6.55 ms)
1	0	0	$2^{15} \times 1/f_{xx}$	$2^{15} \times 1/f_x$ (6.55 ms)	$2^{16} \times 1/f_x$ (13.1 ms)
1	0	1	$2^{16} \times 1/f_{xx}$	$2^{16} \times 1/f_x$ (13.1 ms)	$2^{17} \times 1/f_x$ (26.2 ms)
1	1	0	$2^{17} \times 1/f_{xx}$	$2^{17} \times 1/f_x$ (26.2 ms)	$2^{18} \times 1/f_x$ (52.4 ms)
1	1	1	$2^{19} \times 1/f_{xx}$	$2^{19} \times 1/f_x$ (104.9 ms)	$2^{20} \times 1/f_x$ (209.7 ms)

- Remarks**
1. f_{xx} : Main system clock frequency (f_x or $f_x/2$)
 2. f_x : Main system clock oscillation frequency
 3. MCS : Oscillation mode selection register bit 0
 4. Figures in parentheses apply to operation with $f_x = 5.0$ MHz.

11.4.2 Interval timer operation

The watchdog timer operates as an interval timer which generates interrupts repeatedly at an interval of the preset count value when bit 3 (WDTM3) and bit 4 (WDTM4) of the watchdog timer mode register (WDTM) are set to 1 and 0, respectively.

When the watchdog timer operated as interval timer, the interrupt mask flag (TMMK4) and priority specify flag (TMPR4) are validated and the maskable interrupt (INTWDT) can be generated. Among maskable interrupts, the INTWDT default has the highest priority.

The interval timer continues operating in the HALT mode but it stops in STOP mode. Thus, set RUN to 1 before the STOP mode is set, clear the interval timer and then execute the STOP instruction.

- Cautions**
1. Once bit 4 (WDTM4) of WDTM is set to 1 (with the watchdog timer mode selected), the interval timer mode is not set unless $\overline{\text{RESET}}$ input is applied.
 2. The interval time just after setting with WDTM may be shorter than the set time by a maximum of 0.5 %.
 3. When the subsystem clock is selected for CPU clock, watchdog timer count operation is stopped.

Table 11-5. Interval Timer Interval Time

TCL22	TCL21	TCL20	Interval Time	MCS = 1	MCS = 0
0	0	0	$2^{11} \times 1/f_{xx}$	$2^{11} \times 1/f_x$ (410 μs)	$2^{12} \times 1/f_x$ (819 μs)
0	0	1	$2^{12} \times 1/f_{xx}$	$2^{12} \times 1/f_x$ (819 μs)	$2^{13} \times 1/f_x$ (1.64 ms)
0	1	0	$2^{13} \times 1/f_{xx}$	$2^{13} \times 1/f_x$ (1.64 ms)	$2^{14} \times 1/f_x$ (3.28 ms)
0	1	1	$2^{14} \times 1/f_{xx}$	$2^{14} \times 1/f_x$ (3.28 ms)	$2^{15} \times 1/f_x$ (6.55 ms)
1	0	0	$2^{15} \times 1/f_{xx}$	$2^{15} \times 1/f_x$ (6.55 ms)	$2^{16} \times 1/f_x$ (13.1 ms)
1	0	1	$2^{16} \times 1/f_{xx}$	$2^{16} \times 1/f_x$ (13.1 ms)	$2^{17} \times 1/f_x$ (26.2 ms)
1	1	0	$2^{17} \times 1/f_{xx}$	$2^{17} \times 1/f_x$ (26.2 ms)	$2^{18} \times 1/f_x$ (52.4 ms)
1	1	1	$2^{19} \times 1/f_{xx}$	$2^{19} \times 1/f_x$ (104.9 ms)	$2^{20} \times 1/f_x$ (209.7 ms)

- Remarks**
1. f_{xx} : Main system clock frequency (f_x or $f_x/2$)
 2. f_x : Main system clock oscillation frequency
 3. MCS : Oscillation mode selection register bit 0
 4. Figures in parentheses apply to operation with $f_x = 5.0$ MHz.

CHAPTER 12 CLOCK OUTPUT CONTROL CIRCUIT

12.1 Clock Output Control Circuit Functions

The clock output control circuit is intended for carrier output during remote controlled transmission and clock output for supply to peripheral LSI. Clocks selected with the timer clock select register 0 (TCL0) are output from the PCL/P35 pin.

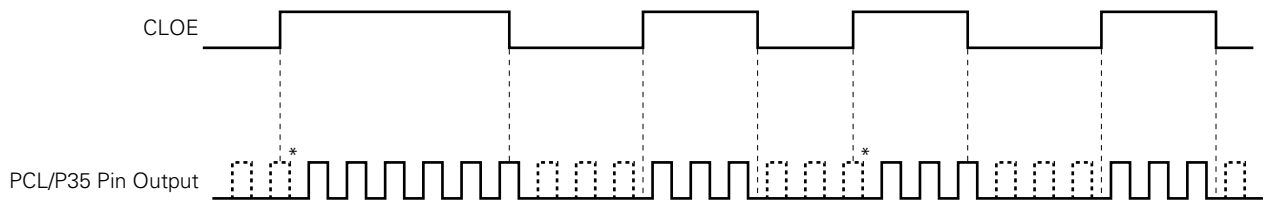
Follow the procedure below to output clock pulses.

- (1) Select the clock pulse output frequency (with clock pulse output disabled) with bits 0 to 3 (TCL00 to TCL03) of TCL0.
- (2) Set the P35 output latch to 0.
- (3) Set bit 5 (PM35) of port mode register 3 to 0 (set to output mode).
- (4) Set bit 7 (CLOE) of timer clock select register 0 to 1.

Caution Clock output cannot be used when setting P35 output latch to 1.

Remark When clock output enable/disable is switched, the clock output control circuit does not output pulses with small widths (See the portions marked with * in **Figure 12-1**).

Figure 12-1. Remote Controlled Output Application Example



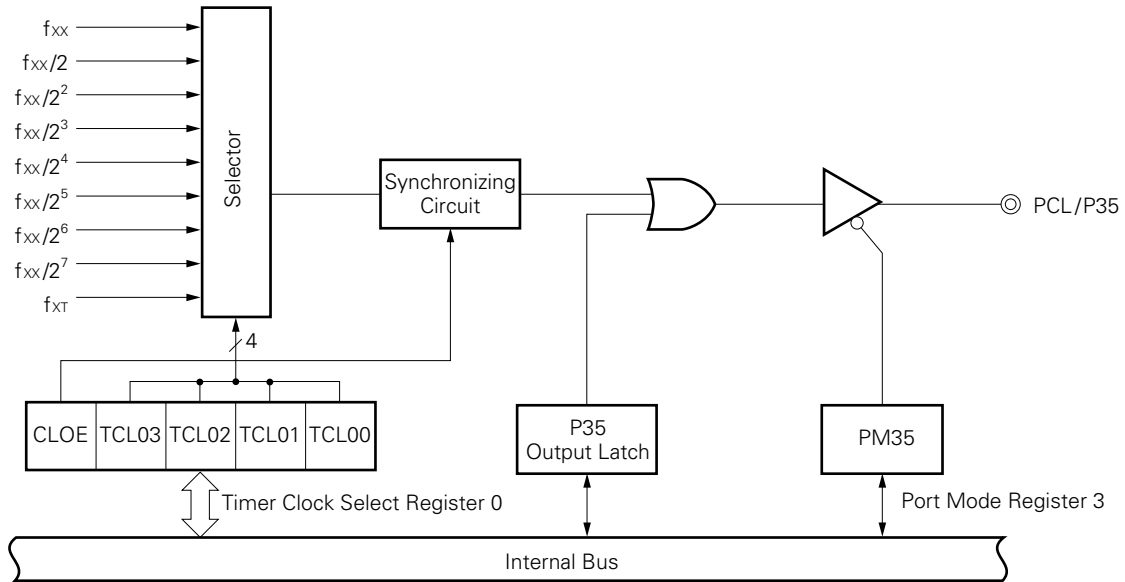
12.2 Clock Output Control Circuit Configuration

The clock output control circuit consists of the following hardware.

Table 12-1. Clock Output Control Circuit Configuration

Item	Configuration
Control register	Timer clock select register 0 (TCL0) Port mode register 3 (PM3)

Figure 12-2. Clock Output Control Circuit Block Diagram



www.DataSheet4U.com

12.3 Clock Output Function Control Registers

The following two types of registers are used to control the clock output function.

- Timer clock select register 0 (TCL0)
- Port mode register 3 (PM3)

(1) Timer clock select register 0 (TCL0)

This register sets PCL output clock.

TCL0 is set with a 1-bit or 8-bit memory manipulation instruction.

RESET input sets TCL0 to 00H.

Remark Besides setting PCL output clock, TCL0 sets the 16-bit timer register count clock.

- Cautions**
1. **Setting of the TI00/INTP0 pin valid edge is performed by external interrupt mode register 0, and selection of the sampling clock frequency is performed by the sampling clock selection register.**
 2. **When enabling PCL output, set TCL00 to TCL03, then set 1 in CLOE with a 1-bit memory manipulation instruction.**
 3. **To read the count value when TI00 has been specified as the TM0 count clock, the value should be read from TM0, not from capture/compare register 01 (CR01).**
 4. **When rewriting TCL0 to other data, stop the timer operation beforehand.**

Figure 12-3. Timer Clock Select Register 0 Format

Symbol	⑦	6	5	4	3	2	1	0	Address	After Reset	R/W
TCL0	CLOE	TCL06	TCL05	TCL04	TCL03	TCL02	TCL01	TCL00	FF40H	00H	R/W

TCL03	TCL02	TCL01	TCL00	PCL Output Clock Selection		
				MCS=1		MCS=0
0	0	0	0	f _{XT} (32.768 kHz)		
0	1	0	1	f _{XX}	f _X (5.0 MHz)	f _X /2 (2.5 MHz)
0	1	1	0	f _{XX} /2	f _X /2 (2.5 MHz)	f _X /2 ² (1.25 MHz)
0	1	1	1	f _{XX} /2 ²	f _X /2 ² (1.25 MHz)	f _X /2 ³ (625 kHz)
1	0	0	0	f _{XX} /2 ³	f _X /2 ³ (625 kHz)	f _X /2 ⁴ (313 kHz)
1	0	0	1	f _{XX} /2 ⁴	f _X /2 ⁴ (313 kHz)	f _X /2 ⁵ (156 kHz)
1	0	1	0	f _{XX} /2 ⁵	f _X /2 ⁵ (156 kHz)	f _X /2 ⁶ (78.1 kHz)
1	0	1	1	f _{XX} /2 ⁶	f _X /2 ⁶ (78.1 kHz)	f _X /2 ⁷ (39.1 kHz)
1	1	0	0	f _{XX} /2 ⁷	f _X /2 ⁷ (39.1 kHz)	f _X /2 ⁸ (19.5 kHz)
Other than above				Setting prohibited		

TCL06	TCL05	TCL04	16-Bit Timer Register Count Clock Selection			
			MCS=1		MCS=0	
0	0	0	TI00 (Valid edge specifiable)			
0	0	1	2f _{XX}	Setting prohibited		f _X (5.0 MHz)
0	1	0	f _{XX}	f _X (5.0 MHz)	f _X /2 (2.5 MHz)	
0	1	1	f _{XX} /2	f _X /2 (2.5 MHz)	f _X /2 ² (1.25 MHz)	
1	0	0	f _{XX} /2 ²	f _X /2 ² (1.25 MHz)	f _X /2 ³ (625 kHz)	
1	1	1	Watch Timer Output (INTTM3)			
Other than above			Setting prohibited			

CLOE	PCL Output Control
0	Output disable
1	Output enable

- Remarks**
1. f_{XX} : Main system clock frequency (f_X or f_X/2)
 2. f_X : Main system clock oscillation frequency
 3. f_{XT} : Subsystem clock oscillation frequency
 4. TI00 : 16-bit timer/event counter input pin
 5. TM0 : 16-bit timer register
 6. MCS : Oscillation mode selection register bit 0
 7. Figures in parentheses apply to operation with f_X = 5.0 MHz or f_{XT} = 32.768 kHz.

(2) Port mode register 3 (PM3)

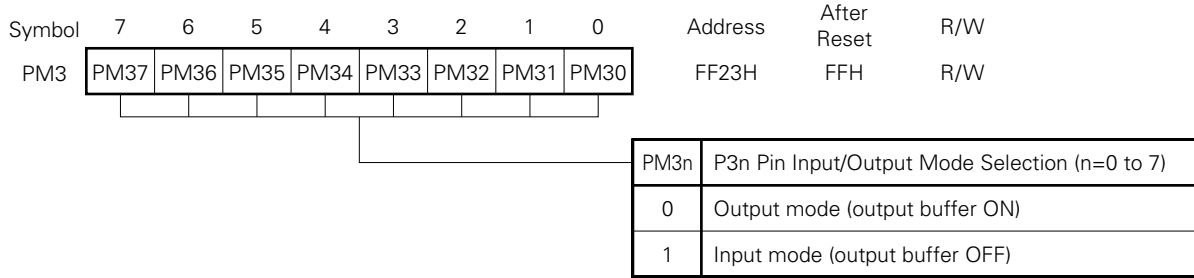
This register set port 3 input/output in 1-bit units.

When using the P35/PCL pin for clock output function, set PM35 and output latch of P35 to 0.

PM3 is set with a 1-bit or 8-bit memory manipulation instruction.

RESET input sets PM3 to FFH.

Figure 12-4. Port Mode Register 3 Format



www.DataSheet4U.com

[MEMO]

www.DataSheet4U.com

CHAPTER 13 BUZZER OUTPUT CONTROL CIRCUIT

13.1 Buzzer Output Control Circuit Functions

The buzzer output control circuit outputs 1.2 kHz, 2.4 kHz, 4.9 kHz, or 9.8 kHz frequency square waves. The buzzer frequency selected with timer clock select register 2 (TCL2) is output from the BUZ/P36 pin.

Follow the procedure below to output the buzzer frequency.

- (1) Select the buzzer output frequency with bits 5 to 7 (TCL25 to TCL27) of TCL2.
- (2) Set the P36 output latch to 0.
- (3) Set bit 6 (PM36) of port mode register 3 to 0 (Set to output mode).

www.DataSheet4U.com

Caution Buzzer output cannot be used when setting P36 output latch to 1.

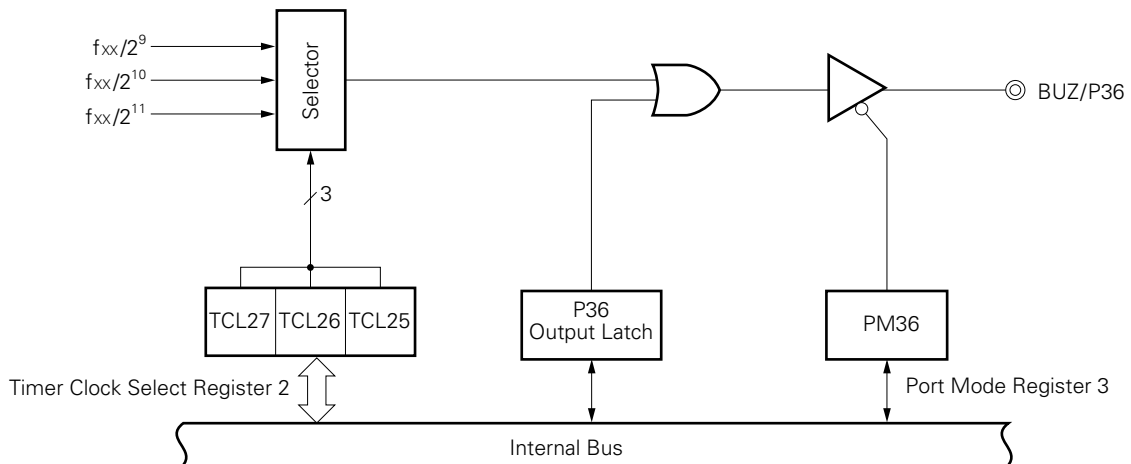
13.2 Buzzer Output Control Circuit Configuration

The buzzer output control circuit consists of the following hardware.

Table 13-1. Buzzer Output Control Circuit Configuration

Item	Configuration
Control register	Timer clock select register 2 (TCL2) Port mode register 3 (PM3)

Figure 13-1. Buzzer Output Control Circuit Block Diagram



13.3 Buzzer Output Function Control Registers

The following two types of registers are used to control the buzzer output function.

- Timer clock select register 2 (TCL2)
- Port mode register 3 (PM3)

(1) Timer clock select register 2 (TCL2)

This register sets the buzzer output frequency.

TCL2 is set with an 8-bit memory manipulation instruction.

RESET input sets TCL2 to 00H.

www.DataSheet4U.com **Remark** Besides setting the buzzer output frequency, TCL2 sets the watch timer count clock and the watchdog timer count clock.

Figure 13-2. Timer Clock Select Register 2 Format

Symbol	7	6	5	4	3	2	1	0	Address	After Reset	R/W
TCL2	TCL27	TCL26	TCL25	TCL24	0	TCL22	TCL21	TCL20	FF42H	00H	R/W

TCL22	TCL21	TCL20	Watchdog Timer Count Clock Selection		
				MCS=1	MCS=0
0	0	0	$f_{xx}/2^3$	$f_x/2^3$ (625 kHz)	$f_x/2^4$ (313 kHz)
0	0	1	$f_{xx}/2^4$	$f_x/2^4$ (313 kHz)	$f_x/2^5$ (156 kHz)
0	1	0	$f_{xx}/2^5$	$f_x/2^5$ (156 kHz)	$f_x/2^6$ (78.1 kHz)
0	1	1	$f_{xx}/2^6$	$f_x/2^6$ (78.1 kHz)	$f_x/2^7$ (39.1 kHz)
1	0	0	$f_{xx}/2^7$	$f_x/2^7$ (39.1 kHz)	$f_x/2^8$ (19.5 kHz)
1	0	1	$f_{xx}/2^8$	$f_x/2^8$ (19.5 kHz)	$f_x/2^9$ (9.8 kHz)
1	1	0	$f_{xx}/2^9$	$f_x/2^9$ (9.8 kHz)	$f_x/2^{10}$ (4.9 kHz)
1	1	1	$f_{xx}/2^{11}$	$f_x/2^{11}$ (2.4 kHz)	$f_x/2^{12}$ (1.2 kHz)

TCL24	Watch Timer Count Clock Selection		
		MCS=1	MCS=0
0	$f_{xx}/2^7$	$f_x/2^7$ (39.1 kHz)	$f_x/2^8$ (19.5 kHz)
1	f_{xt} (32.768 kHz)		

TCL27	TCL26	TCL25	Buzzer Output Frequency Selection		
				MCS=1	MCS=0
0	×	×	Buzzer output disable		
1	0	0	$f_{xx}/2^9$	$f_x/2^9$ (9.8 kHz)	$f_x/2^{10}$ (4.9 kHz)
1	0	1	$f_{xx}/2^{10}$	$f_x/2^{10}$ (4.9 kHz)	$f_x/2^{11}$ (2.4 kHz)
1	1	0	$f_{xx}/2^{11}$	$f_x/2^{11}$ (2.4 kHz)	$f_x/2^{12}$ (1.2 kHz)
1	1	1	Setting prohibited		

Caution When rewriting TCL2 to other data, stop the timer operation beforehand.

- Remarks**
1. f_{xx} : Main system clock frequency (f_x or $f_x/2$)
 2. f_x : Main system clock oscillation frequency
 3. f_{xt} : Subsystem clock oscillation frequency
 4. × : don't care
 5. MCS : Oscillation mode selection register bit 0
 6. Figures in parentheses apply to operation with $f_x = 5.0$ MHz or $f_{xt} = 32.768$ kHz.

(2) Port mode register 3 (PM3)

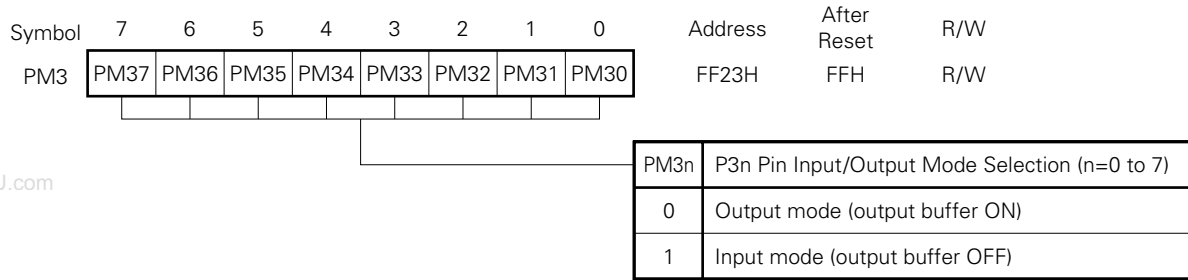
This register sets port 3 input/output in 1-bit units.

When using the P36/BUZ pin for buzzer output function, set PM36 and output latch of P36 to 0.

PM3 is set with a 1-bit or 8-bit memory manipulation instruction.

RESET input sets PM3 to FFH.

Figure 13-3. Port Mode Register 3 Format



www.DataSheet4U.com

CHAPTER 14 A/D CONVERTER

14.1 A/D Converter Functions

The A/D converter converts an analog input into a digital value. It consists of 8 channels (ANI0 to ANI7) with an 8-bit resolution.

The conversion method is based on successive approximation and the conversion result is held in the 8-bit A/D conversion result register (ADCR).

The following two ways are available to start A/D conversion.

(1) Hardware start

Conversion is started by trigger input (INTP3).

(2) Software start

Conversion is started by setting the A/D converter mode register.

One channel of analog input is selected from ANI0 to ANI7 and A/D conversion is carried out. In the case of hardware start, A/D conversion operation stops when an A/D conversion operation ends. In the case of software start, the A/D conversion operation is repeated. Each time an A/D conversion operation ends, an interrupt request (INTAD) is generated.

14.2 A/D Converter Configuration

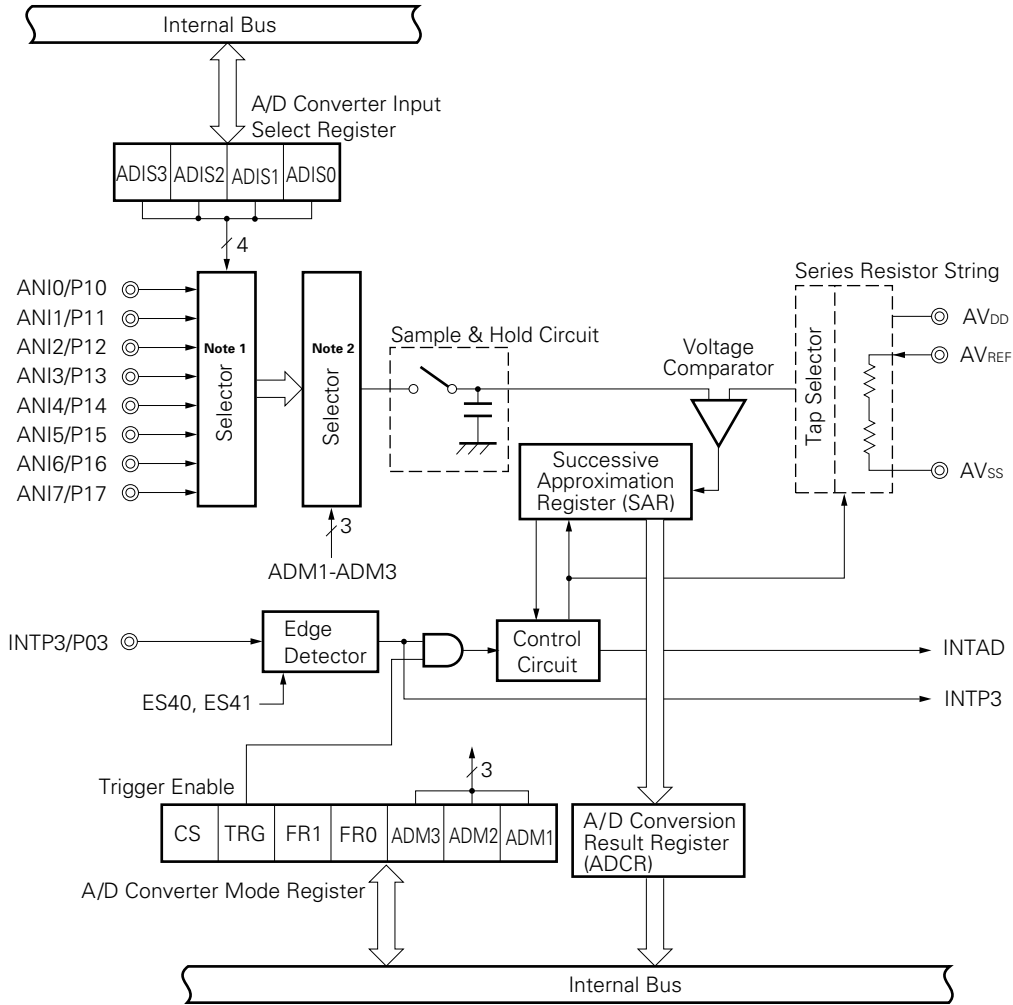
The A/D converter consists of the following hardware.

Table 14-1. A/D Converter Configuration

Item	Configuration
Analog input	8 Channels (ANI0 to ANI7)
Control register	A/D converter mode register (ADM) A/D converter input select register (ADIS) External interrupt mode register 1 (INTM1)
Register	Successive approximation register (SAR) A/D conversion result register (ADCR)

*

Figure 14-1. A/D Converter Block Diagram



- Notes**
1. Selector to select the number of channels to be used for analog input.
 2. Selector to select the channel for A/D conversion.

(1) Successive approximation register (SAR)

This register compares the analog input voltage value to the voltage tap (compare voltage) value applied from the series resistor string and holds the result from the most significant bit (MSB).

When up to the least significant bit (LSB) is set (termination of A/D conversion), the SAR contents are transferred to the A/D conversion result register.

(2) A/D conversion result register (ADCR)

This register holds the A/D conversion result. Each time A/D conversion terminates, the conversion result is loaded from the successive approximation register.

ADCR is read with an 8-bit memory manipulation instruction.

RESET input makes ADCR undefined.

www.DataSheet4U.com

(3) Sample & hold circuit

The sample & hold circuit samples each analog input sequentially applied from the input circuit and sends it to the voltage comparator. This circuit holds the sampled analog input voltage value during A/D conversion.

(4) Voltage comparator

The voltage comparator compares the analog input to the series resistor string output voltage.

(5) Series resistor string

The series resistor string is in AV_{REF} to AV_{SS} and generates a voltage to be compared to the analog input.

(6) ANI0 to ANI7 pins

These are 8-channel analog input pins to input analog signals to undergo A/D conversion to the A/D converter. Pins other than those selected as analog input by the A/D converter input select register (ADIS) can be used as input/output ports.

Caution Use ANI0 to ANI7 input voltages within the specified range. If a voltage higher than AV_{REF} or lower than AV_{SS} is applied (even if within the absolute maximum ratings), the converted value of the corresponding channel becomes indeterminate and may adversely affect the converted values of other channels.

(7) AV_{REF} pin

This pin inputs the A/D converter reference voltage.

It converts signals input to ANI0 to ANI7 into digital signals according to the voltage applied between AV_{REF} and AV_{SS} .

The current flowing in the series resistor string can be reduced by setting the voltage to be input to the AV_{REF} pin to AV_{SS} level in standby mode.

(8) AV_{SS} pin

This is a GND potential pin of the A/D converter. Keep it at the same potential as the V_{SS} pin when not using the A/D converter.

(9) AV_{DD} pin

This is an A/D converter analog power supply pin. Keep it at the same potential as the V_{SS} pin when not using the A/D converter.

14.3 A/D Converter Control Registers

The following three types of registers are used to control the A/D converter.

- A/D converter mode register (ADM)
- A/D converter input select register (ADIS)
- External interrupt mode register 1 (INTM1)

(1) A/D converter mode register (ADM)

This register sets the analog input channel for A/D conversion, conversion time, conversion start/stop and external trigger.

ADM is set with a 1-bit or 8-bit memory manipulation instruction.

www.DataSheet4U.com RESET input sets ADM to 01H.

Figure 14-2. A/D Converter Mode Register Format

Symbol	⑦	⑥	5	4	3	2	1	0	Address	After Reset	R/W
ADM	CS	TRG	FR1	FR0	ADM3	ADM2	ADM1	HSC	FF80H	01H	R/W

ADM3	ADM2	ADM1	Analog Input Channel Selection
0	0	0	ANI0
0	0	1	ANI1
0	1	0	ANI2
0	1	1	ANI3
1	0	0	ANI4
1	0	1	ANI5
1	1	0	ANI6
1	1	1	ANI7

FR1	FR0	HSC	A/D Conversion Time Selection ^{Note 1}			
			fx =5.0 MHz Operation		fx =4.19 MHz Operation	
			MCS=1	MCS=0	MCS=1	MCS=0
0	0	1	80/fx (Setting prohibited ^{Note 2})	160/fx (32.0 μs)	80/fx (19.1 μs)	160/fx (38.1 μs)
0	1	1	40/fx (Setting prohibited ^{Note 2})	80/fx (Setting prohibited ^{Note 2})	40/fx (Setting prohibited ^{Note 2})	80/fx (19.1 μs)
1	0	0	50/fx (Setting prohibited ^{Note 2})	100/fx (20.0 μs)	50/fx (Setting prohibited ^{Note 2})	100/fx (23.8 μs)
1	0	1	100/fx (20.0 μs)	200/fx (40.0 μs)	100/fx (23.8 μs)	200/fx (47.7 μs)
Other than above			Setting prohibited			

TRG	External Trigger Selection
0	No external trigger (software starts)
1	Conversion started by external trigger (hardware starts)

CS	A/D Conversion Operation Control
0	Operation stop
1	Operation start

- Notes**
1. Set so that the A/D conversion time is 19.1 μs or more.
 2. Setting prohibited because A/D conversion time is less than 19.1 μs.

- Cautions**
1. The following sequence is recommended for power consumption reduction of A/D converter when the standby function is used: Clear bit 7 (CS) to 0 first to stop the A/D conversion operation, and then execute the HALT or STOP instruction.
 2. When restarting the stopped A/D conversion operation, start the A/D conversion operation after clearing the interrupt request flag (ADIF) to 0.

- Remarks**
1. fx : Main system clock oscillation frequency
 2. MCS : Oscillation mode selection register bit 0

(2) A/D converter input select register (ADIS)

This register determines whether the ANI0/P10 to ANI7/P17 pins should be used for analog input channels or ports. Pins other than those selected as analog input can be used as input/output ports.

ADIS is set with an 8-bit memory manipulation instruction.

RESET input sets ADIS to 00H.

Cautions 1. Set the analog input channel in the following order.

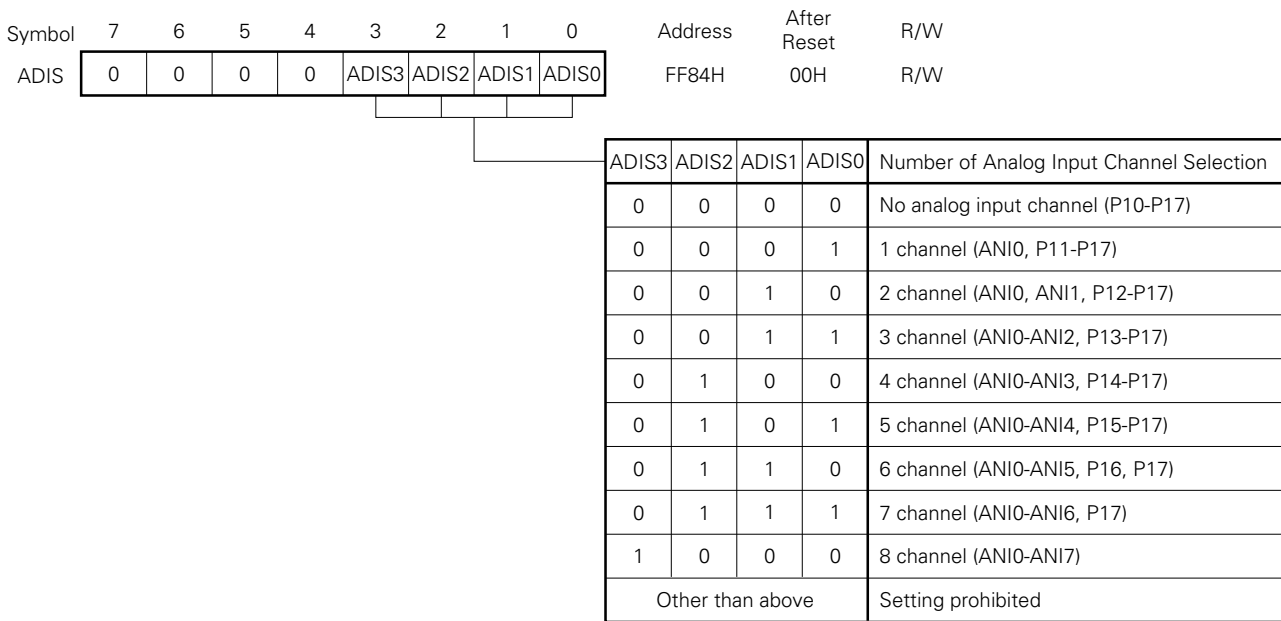
(1) Set the number of analog input channels with ADIS.

(2) Using ADM, select one channel to undergo A/D conversion from among the channels set for analog input with ADIS.

2. No internal pull-up resistor can be connected to the channels set for analog input with ADIS, irrespective of the value of bit 1 (PUO1) of the pull-up resistor option register L.

www.DataSheet4U.com

Figure 14-3. A/D Converter Input Select Register Format



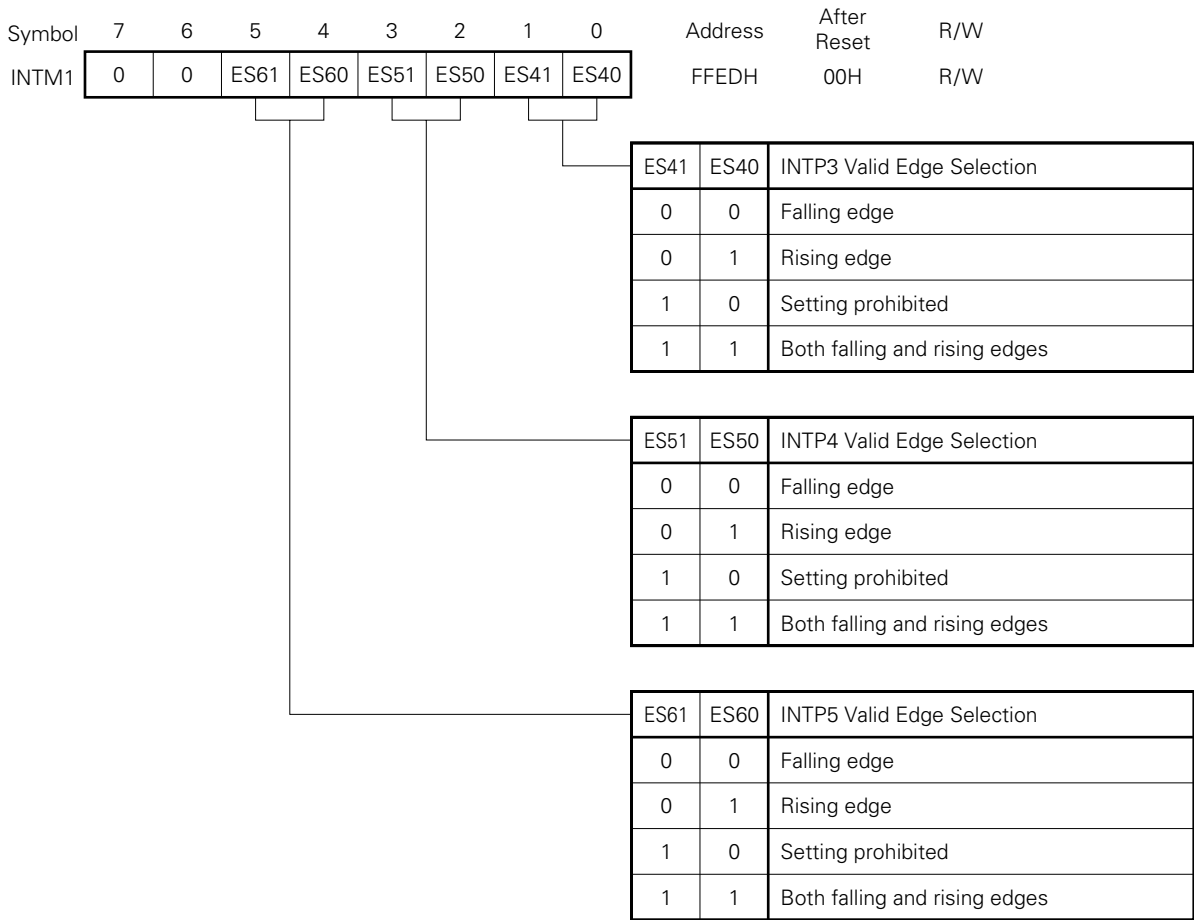
(3) External interrupt mode register 1 (INTM1)

This register sets the valid edge for INTP3 to INTP5.

INTM1 is set with an 8-bit memory manipulation instruction.

$\overline{\text{RESET}}$ input sets INTM1 to 00H.

Figure 14-4. External Interrupt Mode Register 1 Format



www.DataSheet4U.com

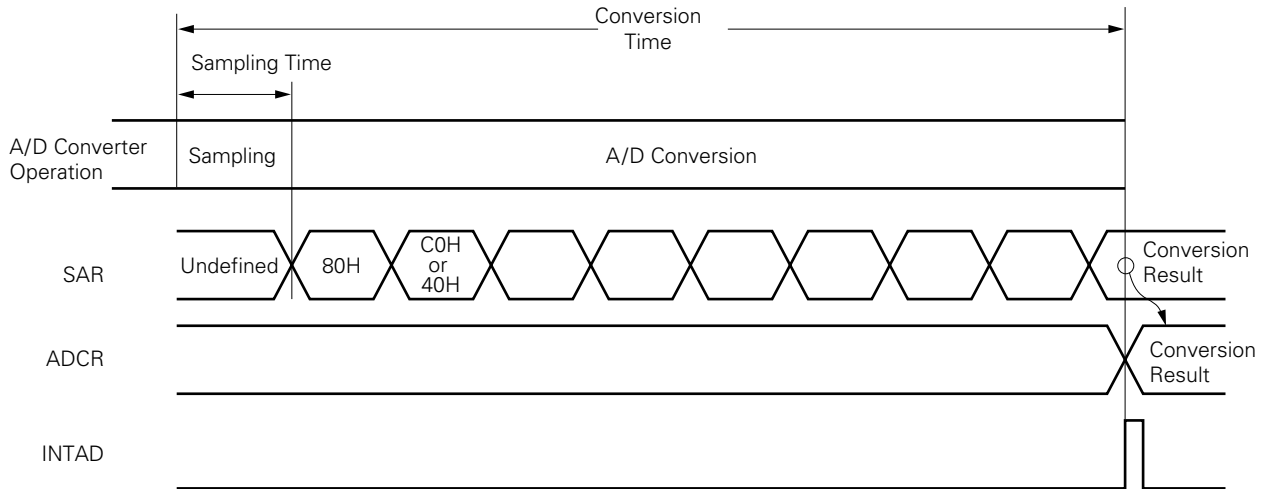
14.4 A/D Converter Operations

14.4.1 Basic operations of A/D converter

- (1) Set the number of analog input channels with A/D converter input select register (ADIS).
- (2) From among the analog input channels set with ADIS, select one channel for A/D conversion with A/D converter mode register (ADM).
- (3) Sample the voltage input to the selected analog input channel with the sample & hold circuit.
- (4) Sampling for the specified period of time sets the sample & hold circuit to the hold state so that the circuit holds the input analog voltage until termination of A/D conversion.
- (5) Bit 7 of the successive approximation register (SAR) is set and the tap selector sets the series resistor string voltage tap to $(1/2) AV_{REF}$.
- (6) The voltage difference between the series resistor string voltage tap and analog input is compared with a voltage comparator. If the analog input is greater than $(1/2) AV_{REF}$, the MSB of SAR remains set. If the input is smaller than $(1/2) AV_{REF}$, the MSB is reset.
- (7) Next, bit 6 of SAR is automatically set and the operation proceeds to the next comparison. In this case, the series resistor string voltage tap is selected according to the preset value of bit 7 as described below.
 - Bit 7 = 1 : $(3/4) AV_{REF}$
 - Bit 7 = 0 : $(1/4) AV_{REF}$The voltage tap and analog input voltage are compared and bit 6 of SAR is manipulated with the result as follows.
 - Analog input voltage \geq Voltage tap : Bit 6 = 1
 - Analog input voltage \leq Voltage tap : Bit 6 = 0
- (8) Comparison of this sort continues up to bit 0 of SAR.
- (9) Upon completion of the comparison of 8 bits, any effective digital resultant value remains in SAR and the resultant value is transferred to and latched in the A/D conversion result register (ADCR).

At the same time, the A/D conversion termination interrupt request (INTAD) can also be generated.

Figure 14-5. A/D Converter Basic Operation



A/D conversion operations are performed continuously until the CS bit is reset (0) by software.

If a write to the ADM register is performed during an A/D conversion operation, the conversion operation is initialized, and if the CS bit is set (1), conversion starts again from the beginning.

After RESET input, the value of APCR is undefined.

14.4.2 Input voltage and conversion results

The relation between the analog input voltage input to the analog input pins (ANI0 to ANI7) and the A/D conversion result (the value stored in ADCR) is shown by the following expression.

$$ADCR = \text{INT} \left(\frac{V_{IN}}{AV_{REF}} \times 256 + 0.5 \right)$$

or

$$(ADCR - 0.5) \times \frac{AV_{REF}}{256} \leq V_{IN} < (ADCR + 0.5) \times \frac{AV_{REF}}{256}$$

INT() : Function which returns integer parts of value in parentheses.

V_{IN} : Analog input voltage

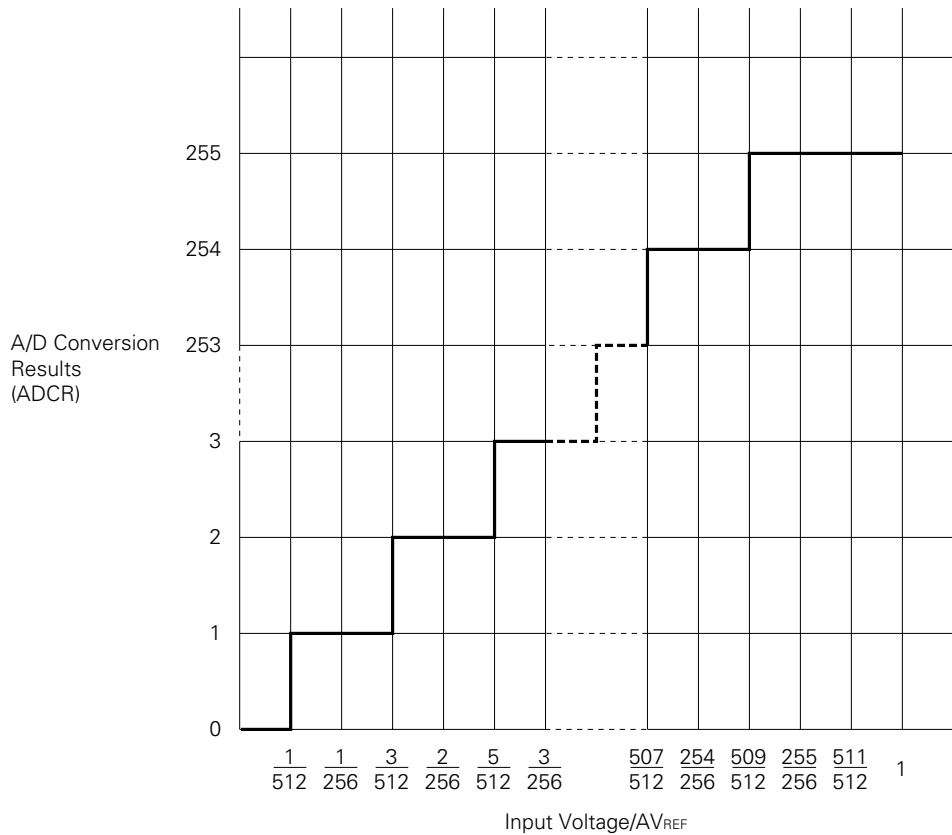
AV_{REF} : AV_{REF} pin voltage

ADCR : ADCR register value

www.DataSheet4U.com

Figure 14-6 shows the relation between the analog input voltage and the A/D conversion result.

Figure 14-6. Relations between Analog Input Voltage and A/D Conversion Result



14.4.3 A/D converter operating mode

The operating mode is a select mode. One analog input channel is selected from among ANI0 to ANI7 with the A/D converter input select register (ADIS) and A/D converter mode register (ADM) and A/D conversion is executed.

The following two ways are available to start A/D conversion.

- Hardware start: Conversion is started by trigger input (INTP3).
- Software start: Conversion is started by setting ADM.

The A/D conversion result is stored in the A/D conversion result register (ADCR) and the interrupt request signal (INTAD) is simultaneously generated.

(1) A/D conversion by hardware start

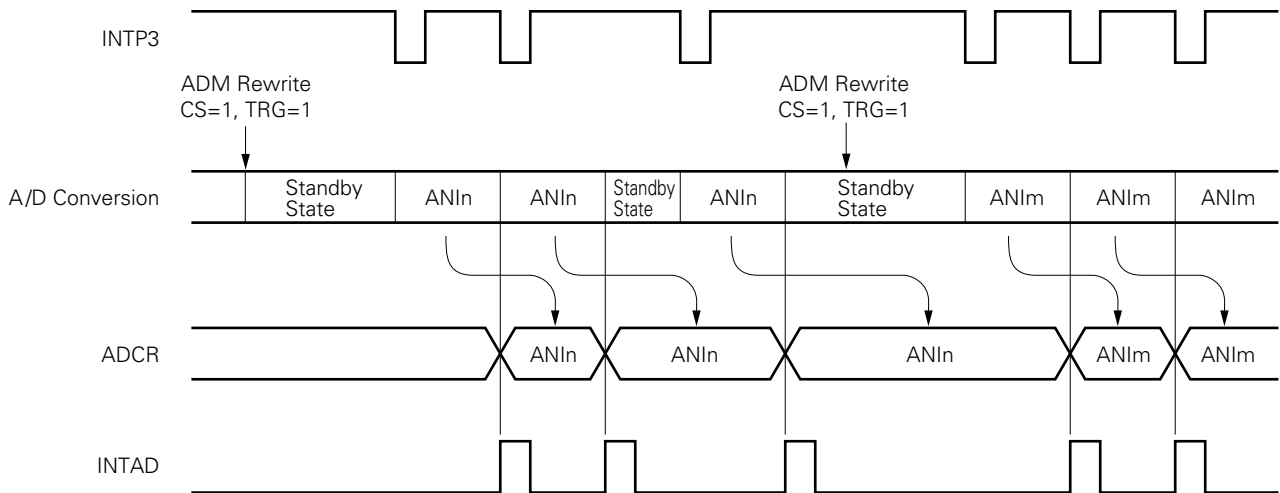
When bit 6 (TRG) and bit 7 (CS) of ADM are set to 1, the A/D conversion standby state is set. When the external trigger signal (INTP3) is input, the A/D conversion starts on the voltage applied to the analog input pins specified with bits 1 to 3 (ADM1 to ADM3) of ADM.

Upon termination of the A/D conversion, the conversion result is stored in the A/D conversion result register (ADCR) and the interrupt request signal (INTAD) is generated. After one A/D conversion operation is started and terminated, another operation is not started until a new external trigger signal is input.

If data with CS set to 1 is written to ADM again during A/D conversion, the converter suspends its A/D conversion operation and waits for a new external trigger signal to be input. When the external trigger input signal is reinput, A/D conversion is carried out from the beginning.

If data with CS set to 0 is written to ADM during A/D conversion, the A/D conversion operation stops immediately.

Figure 14-7. A/D Conversion by Hardware Start



- Remarks**
1. $n = 0, 1, \dots, 7$
 2. $m = 0, 1, \dots, 7$

(2) A/D conversion operation in software start

When bit 6 (TRG) and bit 7 (CS) of A/D converter mode register (ADM) are set to 0 and 1, respectively, the A/D conversion starts on the voltage applied to the analog input pins specified with bits 1 to 3 (ADM1 to ADM3) of ADM.

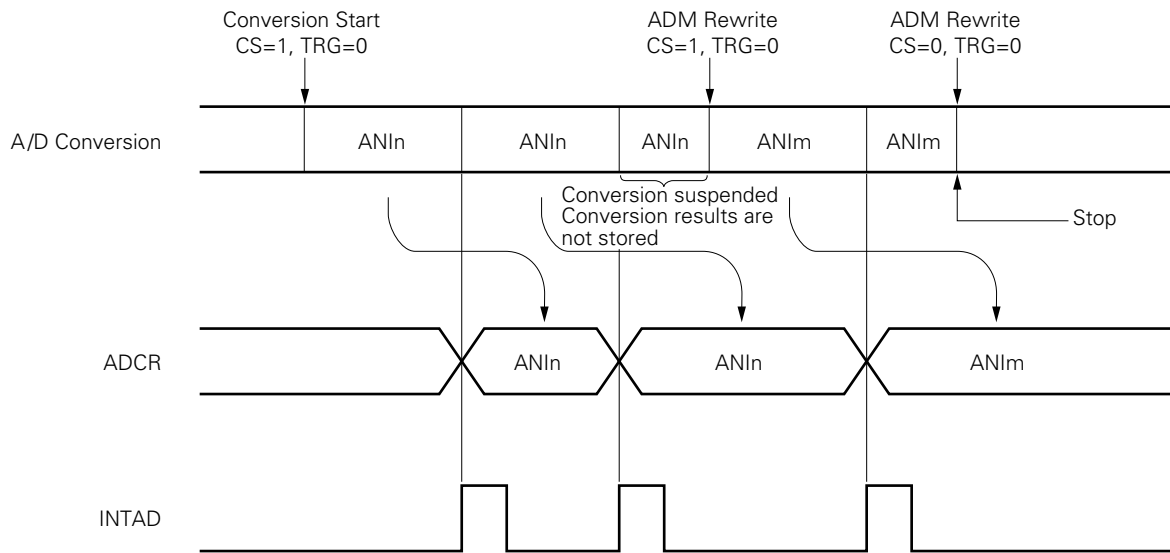
Upon termination of the A/D conversion, the conversion result is stored in the A/D conversion result register (ADCR) and the interrupt request signal (INTAD) is generated. After one A/D conversion operation is started and terminated, the next A/D conversion operation starts immediately. The A/D conversion operation continues repeatedly until new data is written to ADM.

If data with CS set to 1 is written to ADM again during A/D conversion, the converter suspends its A/D conversion operation and starts A/D conversion on the newly written data.

If data with CS set to 0 is written to ADM during A/D conversion, the A/D conversion operation stops immediately.

www.DataSheet4U.com

Figure 14-8. A/D Conversion by Software Start



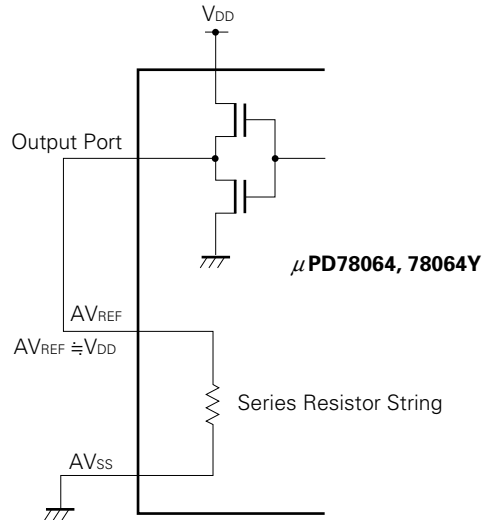
- Remarks**
1. $n = 0, 1, \dots, 7$
 2. $m = 0, 1, \dots, 7$

14.5 A/D Converter Cautions

(1) Current consumption in standby mode

The A/D converter operates on the main system clock. Therefore, its operation stops in STOP mode or in HALT mode with the subsystem clock. As a current still flows in the AV_{REF} pin at this time, this current must be cut in order to minimize the overall system power dissipation. In Figure 14-9, the power dissipation can be reduced by outputting a low-level signal to the output port in standby mode. However, there is no precision to the actual AV_{REF} voltage, and therefore the conversion values themselves lack precision and can only be used for relative comparison.

Figure 14-9. Example of Method of Reducing Current Consumption in Standby Mode



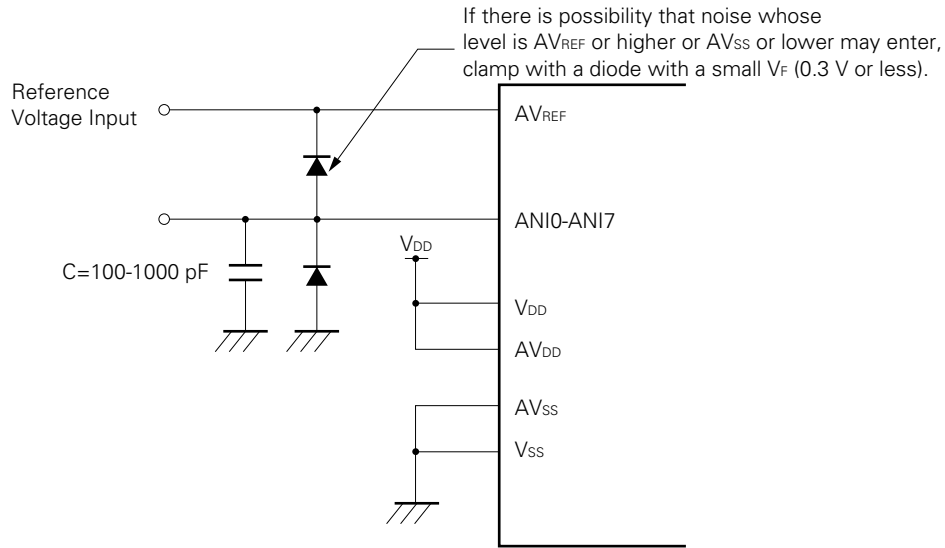
(2) Input range of ANI0 to ANI7

The input voltages of ANI0 to ANI7 should be within the specification range. In particular, if a voltage above AV_{REF} or below AV_{SS} is input (even if within the absolute maximum rating range), the conversion value for that channel will be indeterminate. The conversion values of the other channels may also be affected.

(3) Noise countermeasures

In order to maintain 8-bit resolution, attention must be paid to noise on pins AV_{REF} and ANI0 to ANI7. Since the effect increases in proportion to the output impedance of the analog input source, it is recommended that a capacitor be connected externally as shown in Figure 14-10 in order to reduce noise.

Figure 14-10. Analog Input Pin Disposition



(4) Pins ANI0/P10 to ANI7/P17

The analog input pins ANI0 to ANI7 also function as input/output port (PORT1) pins. When A/D conversion is performed with any of pins ANI0 to ANI7 selected, be sure not to execute a PORT1 input instruction while conversion is in progress, as this may reduce the conversion resolution.

Also, if digital pulses are applied to a pin adjacent to the pin in the process of A/D conversion, the expected A/D conversion value may not be obtainable due to coupling noise. Therefore, avoid applying pulses to pins adjacent to the pin undergoing A/D conversion.

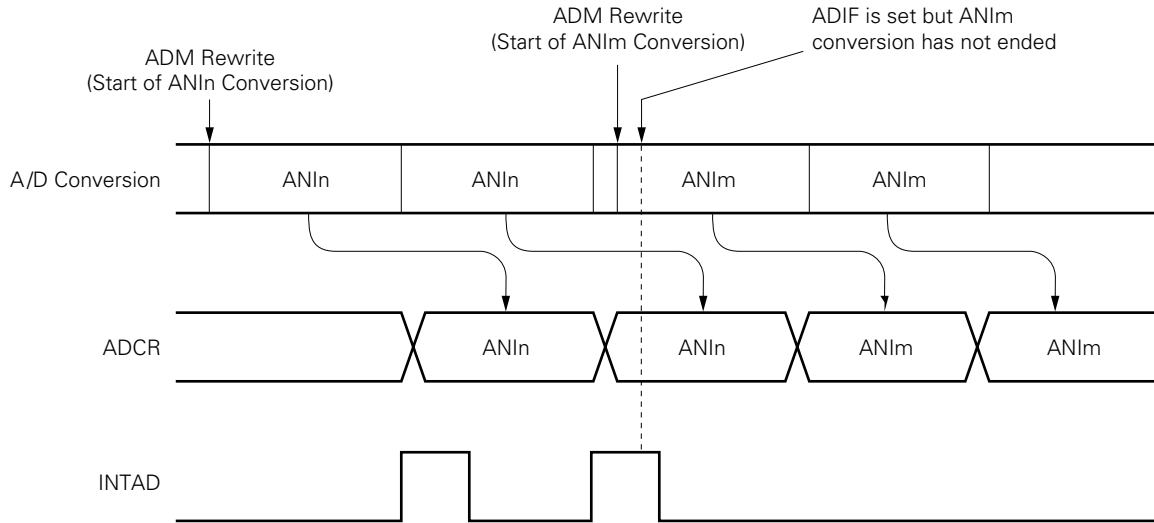
(5) AV_{REF} pin input impedance

A series resistor string of approximately $10\text{ k}\Omega$ is connected between the AV_{REF} pin and the AV_{SS} pin. Therefore, if the output impedance of the reference voltage source is high, this will result in parallel connection to the series resistor string between the AV_{REF} pin and the AV_{SS} pin, and there will be a large reference voltage error.

(6) Interrupt request flag (ADIF)

The interrupt request flag (ADIF) is not cleared even if the A/D converter mode register (ADM) is changed. Caution is therefore required since, if a change of analog input pin is performed during A/D conversion, the A/D conversion result and conversion end interrupt request flag for the pre-change analog input may be set just before the ADM rewrite, and when ADIF is read immediately after the ADM rewrite, ADIF may be set despite the fact that the A/D conversion for the post-change analog input has not ended. When the A/D conversion is stopped and then resumed, clear the interrupt request flag (ADIF) before it is resumed.

Figure 14-11. A/D Conversion End Interrupt Generation Timing



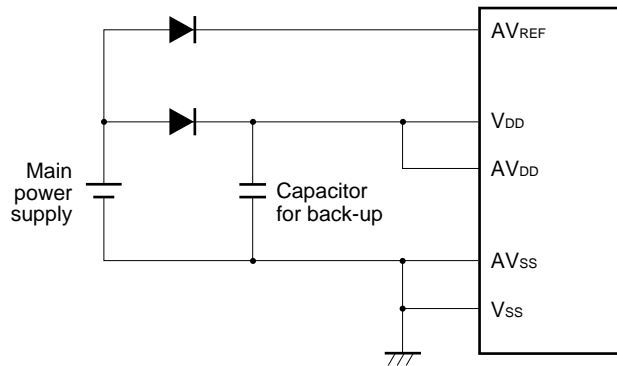
(7) AV_{DD} pin

The AV_{DD} pin is the analog circuit power supply pin, and supplies power to the input circuits of ANI0/P10 to ANI7/P17.

Therefore, be sure to apply the same voltage as V_{DD} to this pin even when the application circuit is designed so as to switch to a backup battery.

Figure 14-12. Handling of AV_{DD} Pin

*



[MEMO]

www.DataSheet4U.com

CHAPTER 15 SERIAL INTERFACE CHANNEL 0 (μ PD78064 Subseries)

The μ PD78064 subseries incorporates two channels of serial interfaces. Differences between channels 0 and 2 are as follows (Refer to **CHAPTER 17 SERIAL INTERFACE CHANNEL 2** for details of the serial interface channel 2).

Table 15-1. Differences between Channels 0 and 2

Serial Transfer Mode		Channel 0	Channel 2
3-wire serial I/O	Clock selection	$f_{xx}/2$, $f_{xx}/2^2$, $f_{xx}/2^3$, $f_{xx}/2^4$, $f_{xx}/2^5$, $f_{xx}/2^6$, $f_{xx}/2^7$, $f_{xx}/2^8$, external clock, TO2 output	External clock, baud rate generator output
	Transfer method	MSB/LSB switchable as the start bit	MSB/LSB switchable as the start bit
	Transfer end flag	Serial transfer end interrupt request flag (CSIF0)	Serial transfer end interrupt request flag (SRIF)
SBI (serial bus interface)	Use possible	None	
2-wire serial I/O			
UART (Asynchronous serial interface)	None	Use possible	

15.1 Serial Interface Channel 0 Functions

Serial interface channel 0 employs the following four modes.

- Operation stop mode
- 3-wire serial I/O mode
- SBI (serial bus interface) mode
- 2-wire serial I/O mode

(1) Operation stop mode

This mode is used when serial transfer is not carried out. Power consumption can be reduced.

(2) 3-wire serial I/O mode (MSB-/LSB-first selectable)

This mode is used for 8-bit data transfer using three lines, one each for serial clock ($\overline{\text{SCK0}}$), serial output (SO0) and serial input (SI0). This mode enables simultaneous transmission/reception and therefore reduces the data transfer processing time.

The start bit of transferred 8-bit data is switchable between MSB and LSB, so that devices can be connected regardless of their start bit recognition.

This mode should be used when connecting with peripheral I/O devices or display controllers which incorporate a conventional synchronous clocked serial interface as is the case with the 75X, 78K, and 17K series.

(3) SBI (serial bus interface) mode (MSB-first)

This mode is used for 8-bit data transfer with two or more devices using two lines of serial clock ($\overline{\text{SCK0}}$) and serial data bus (SB0 or SB1).

The SBI mode is in compliance with the NEC serial bus format. In the SBI mode, the transmitter outputs three kinds of data onto the serial data bus: "addresses" to select a device to be communicated with, "commands" to give instructions to the selected device, and "data" to be actually sent or received. The receiver automatically distinguishes the received data into "address", "command", or "data", by hardware. This function enables the input/output ports to be used effectively and the application program serial interface control portions to be simplified.

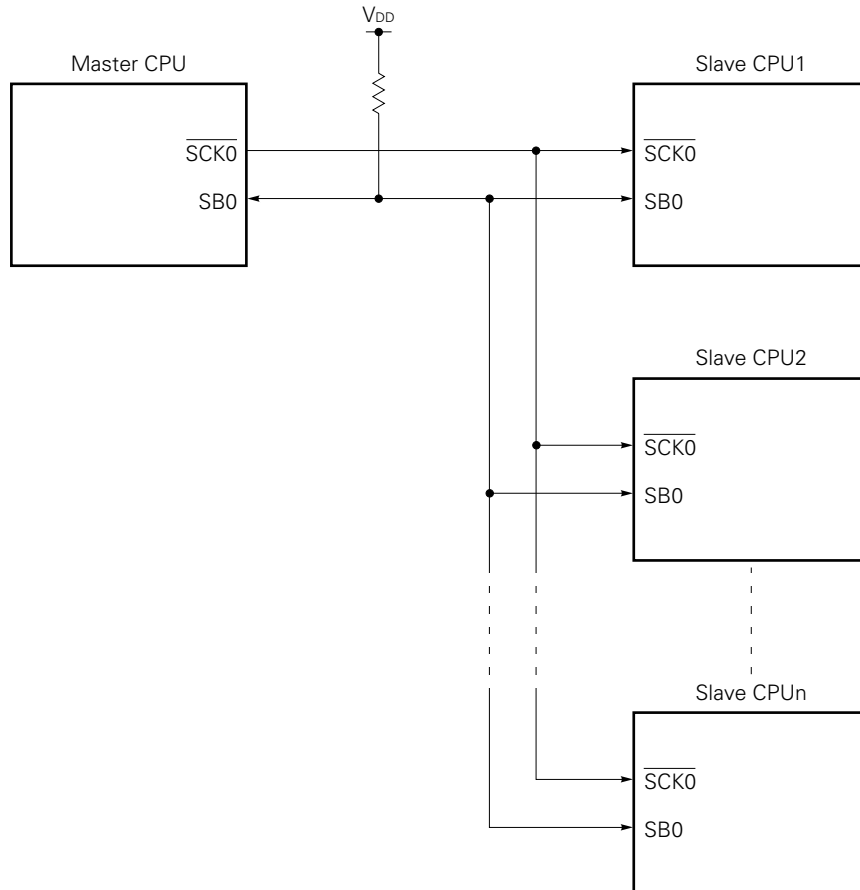
In this mode, the wake-up function for handshake and the output function of acknowledge and busy signals can also be used.

(4) 2-wire serial I/O mode (MSB-first)

This mode is used for 8-bit data transfer using two lines of serial clock ($\overline{\text{SCK0}}$) and serial data bus (SB0 or SB1).

This mode enables to cope with any one of the possible data transfer formats by controlling the $\overline{\text{SCK0}}$ level and the SB0 or SB1 output level. Thus, the handshake line previously necessary for connection of two or more devices can be removed, resulting in the increased number of available input/output ports.

Figure 15-1. Serial Bus Interface (SBI) System Configuration Example



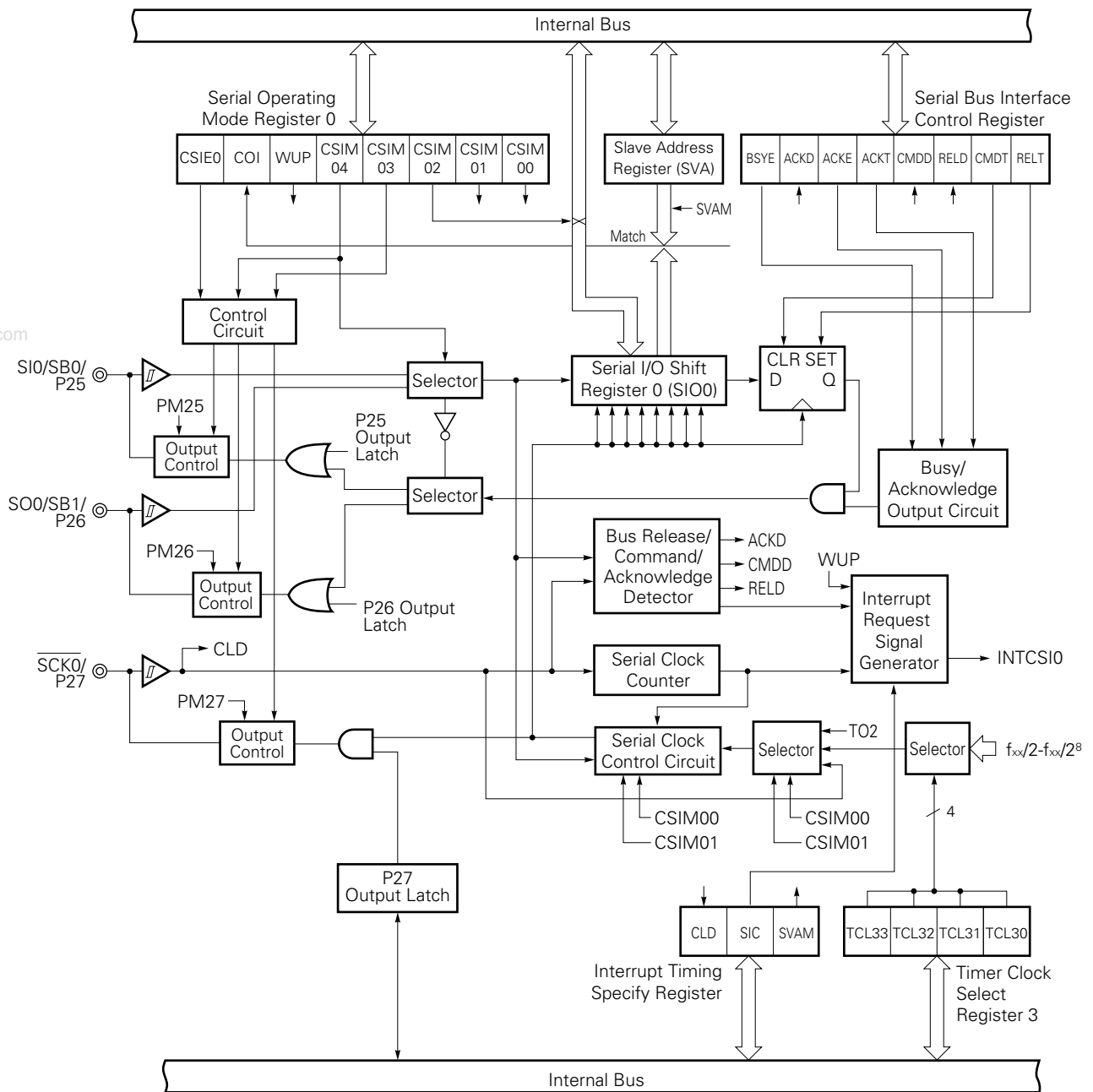
15.2 Serial Interface Channel 0 Configuration

Serial interface channel 0 consists of the following hardware.

Table 15-2. Serial Interface Channel 0 Configuration

Item	Configuration
Register	Serial I/O shift register 0 (SIO0) Slave address register (SVA)
Control register	Timer clock select register 3 (TCL3) Serial operating mode register 0 (CSIM0) Serial bus interface control register (SBIC) Interrupt timing specify register (SINT) Port mode register 2 (PM2)

Figure 15-2. Serial Interface Channel 0 Block Diagram



Remark Output Control performs selection between CMOS output and N-ch open drain output.

(1) Serial I/O shift register 0 (SIO0)

This is an 8-bit register to carry out parallel/serial conversion and to carry out serial transmission/reception (shift operation) in synchronization with the serial clock.

SIO0 is set with an 8-bit memory manipulation instruction.

When bit 7 (CSIE0) of serial operating mode register 0 (CSIM0) is 1, writing data to SIO0 starts serial operation. In transmission, data written to SIO0 is output to the serial output (SO0) or serial data bus (SB0/SB1). In reception, data is read from the serial input (SI0) or SB0/SB1 to SIO0.

Note that, if a bus is driven in the SBI mode or 2-wire serial I/O mode, the bus pin must serve for both input and output. Thus, in the case of a device for reception, write FFH to SIO0 in advance (except when address reception is carried out by setting bit 5 (WUP) of CSIM0 to 1).

In the SBI mode, the busy state can be cleared by writing data to SIO0. In this case, bit 7 (BSYE) of the serial bus interface control register (SBIC) is not cleared to 0.

www.DataSheet4U.com $\overline{\text{RESET}}$ input makes SIO0 undefined.

(2) Slave address register (SVA)

This is an 8-bit register to set the slave address value for connection of a slave device to the serial bus.

SVA is set with an 8-bit memory manipulation instruction.

The master device outputs a slave address for selection of a particular slave device to the connected slave device. These two data (the slave address output from the master device and the SVA value) are compared with an address comparator. If they match, the slave device has been selected. In that case, bit 6 (COI) of serial operating mode register 0 (CSIM0) becomes 1.

Address comparison can also be executed on the data of LSB-masked high-order 7 bits with bit 4 (SVAM) of the interrupt timing specify register (SINT).

If no matching is detected in address reception, bit 2 (RELD) of the serial bus interface control register (SBIC) is cleared to 0. When bit 5 (WUP) of CSIM0 is 1, the interrupt request signal (INTCSI0) is generated only if the matching is detected. This interrupt request enables to recognize the generation of the communication request from the master device.

Further, when SVA transmits data as master or slave device in the SBI or 2-wire serial I/O mode, errors are detected if any.

$\overline{\text{RESET}}$ input makes SVA undefined.

(3) SO0 latch

This latch holds SI0/SB0/P25 and SO0/SB1/P26 pin levels. It can be directly controlled by software. In the SBI mode, this latch is set upon termination of the 8th serial clock.

(4) Serial clock counter

This counter counts the serial clocks to be output and input during transmission/reception and to check whether 8-bit data has been transmitted/received.

(5) Serial clock control circuit

This circuit controls serial clock supply to the serial I/O shift register 0 (SIO0). When the internal system clock is used, the circuit also controls clock output to the $\overline{\text{SCK0}}$ /P27 pin.

www.DataSheet4U.com

(6) Interrupt request signal generator

This circuit controls interrupt request signal generation. It generates the interrupt request signal in the following cases.

- In the 3-wire serial I/O mode and 2-wire serial I/O mode
This circuit generates an interrupt request signal every eight serial clocks.
- In the SBI mode
When WUP is 0 Generates an interrupt request signal every eight serial clocks.
When WUP is 1 Generates an interrupt request signal when the serial I/O shift register 0 (SIO0) value matches the slave address register (SVA) value after address reception.

Remark WUP is wake-up function specify bit. It is bit 5 of serial operating mode register 0 (CSIM0).

(7) Busy/acknowledge output circuit and bus release/command/acknowledge detector

These two circuits output and detect various control signals in the SBI mode.

These do not operate in the 3-wire serial I/O mode and 2-wire serial I/O mode.

15.3 Serial Interface Channel 0 Control Registers

The following four types of registers are used to control serial interface channel 0.

- Timer clock select register 3 (TCL3)
- Serial operating mode register 0 (CSIM0)
- Serial bus interface control register (SBIC)
- Interrupt timing specify register (SINT)

(1) Timer clock select register 3 (TCL3)

This register sets the serial clock of serial interface channel 0.

TCL3 is set with an 8-bit memory manipulation instruction.

www.DataSheet4U.com $\overline{\text{RESET}}$ input sets TCL3 to 88H.

Figure 15-3. Timer Clock Select Register 3 Format

Symbol	7	6	5	4	3	2	1	0	Address	After Reset	R/W
TCL3	1	0	0	0	TCL33	TCL32	TCL31	TCL30	FF43H	88H	R/W

TCL33	TCL32	TCL31	TCL30	Serial Interface Channel 0 Serial Clock Selection		
					MCS = 1	MCS = 0
0	1	1	0	$f_{xx}/2$	Setting prohibited	$f_x/2^2$ (1.25 MHz)
0	1	1	1	$f_{xx}/2^2$	$f_x/2^2$ (1.25 MHz)	$f_x/2^3$ (625 kHz)
1	0	0	0	$f_{xx}/2^3$	$f_x/2^3$ (625 kHz)	$f_x/2^4$ (313 kHz)
1	0	0	1	$f_{xx}/2^4$	$f_x/2^4$ (313 kHz)	$f_x/2^5$ (156 kHz)
1	0	1	0	$f_{xx}/2^5$	$f_x/2^5$ (156 kHz)	$f_x/2^6$ (78.1 kHz)
1	0	1	1	$f_{xx}/2^6$	$f_x/2^6$ (78.1 kHz)	$f_x/2^7$ (39.1 kHz)
1	1	0	0	$f_{xx}/2^7$	$f_x/2^7$ (39.1 kHz)	$f_x/2^8$ (19.5 kHz)
1	1	0	1	$f_{xx}/2^8$	$f_x/2^8$ (19.5 kHz)	$f_x/2^9$ (9.8 kHz)
Other than above				Setting prohibited		

- Cautions**
1. Set bit 4 to bit 6 to 0, and bit 7 to 1.
 2. When rewriting TCL3 to other data, stop the serial transfer operation beforehand.

- Remarks**
1. f_{xx} : Main system clock frequency (f_x or $f_x/2$)
 2. f_x : Main system clock oscillation frequency
 3. MCS : Oscillation mode selection register bit 0
 4. Figures in parentheses apply to operation with $f_x = 5.0$ MHz.

(2) Serial operating mode register 0 (CSIM0)

This register sets serial interface channel 0 serial clock, operating mode, operation enable/stop wake-up function and displays the address comparator match signal.

CSIM0 is set with a 1-bit or 8-bit memory manipulation instruction.

RESET input sets CSIM0 to 00H.

* **Figure 15-4. Serial Operating Mode Register 0 Format (1/2)**

Symbol	⑦	⑥	⑤	4	3	2	1	0	Address	After Reset	R/W
CSIM0	CSIE0	COI	WUP	CSIM04	CSIM03	CSIM02	CSIM01	CSIM00	FF60H	00H	R/W ^{Note 1}

R/W	CSIM01	CSIM00	Serial Interface Channel 0 Clock Selection
	0	×	Input Clock to SCK0 pin from off-chip
	1	0	8-bit timer register 2 (TM2) output
	1	1	Clock specified with bits 0 to 3 of timer clock select register 3 (TCL3)

R/W	CSIM04	CSIM03	CSIM02	PM25	P25	PM26	P26	PM27	P27	Operation Mode	Start Bit	SIO/SB0/P25 Pin Function	SO0/SB1/P26 Pin Function	SCK0/P27 Pin Function
0	×	0	^{Note 2} 1	^{Note 2} ×	0	0	0	1	3-wire serial I/O mode	MSB	SIO ^{Note 2} (Input)	SO0 (CMOS output)	SCK0 (CMOS input/output)	
		1					LSB							
1	0	0	^{Note 3} ×	^{Note 3} ×	0	0	0	1	SBI mode	MSB	P25 (CMOS input/output)	SB1 (N-ch open-drain input/output)	SCK0 (CMOS input/output)	
		1	0	0	^{Note 3} ×	^{Note 3} ×	0	1			SB0 (N-ch open-drain input/output)	P26 (CMOS input/output)		
1	1	0	^{Note 3} ×	^{Note 3} ×	0	0	0	1	2-wire serial I/O mode	MSB	P25 (CMOS input/output)	SB1 (N-ch open-drain input/output)	SCK0 (N-ch open-drain input/output)	
		1	0	0	^{Note 3} ×	^{Note 3} ×	0	1			SB0 (N-ch open-drain input/output)	P26 (CMOS input/output)		

- Notes**
1. Bit 6 (COI) is a read-only bit.
 2. Can be used as P25 (CMOS input/output) when used only for transmission.
 3. Can be used freely as port function.

Remark × : don't care

Figure 15-4. Serial Operating Mode Register 0 Format (2/2)

R/W	WUP	Wake-up Function Control
	0	Interrupt request signal generation with each serial transfer in any mode
	1	Interrupt request signal generation when the address received after bus release (when CMDD = RELD = 1) matches the slave address register data in SBI mode
R	COI	Slave Address Comparison Result Flag ^{Note}
	0	Slave address register not equal to serial I/O shift register 0 data
	1	Slave address register equal to serial I/O shift register 0 data
R/W	CSIE0	Serial Interface Channel 0 Operation Control
	0	Operation stopped
	1	Operation enable

Note When CSIE0 = 0, COI becomes 0.

(3) Serial bus interface control register (SBIC)

This register sets serial bus interface operation and displays statuses.

SBIC is set with a 1-bit or 8-bit memory manipulation instruction.

RESET input sets SBIC to 00H.

Figure 15-5. Serial Bus Interface Control Register Format (1/2)

Symbol	⑦	⑥	⑤	④	③	②	①	①	①	Address	After Reset	R/W
SBIC	BSYE	ACKD	ACKE	ACKT	CMDD	RELD	CMDT	RELT		FF61H	00H	R/W>Note

R/W	RELT	Used for bus release signal output. When RELT = 1, SO latch is set to 1. After SO latch setting, automatically cleared to 0. Also cleared to 0 when CSIE0 = 0.
-----	------	--

R/W	CMDT	Used for command signal output. When CMDT = 1, SO latch is cleared to (0). After SO latch clearance, automatically cleared to 0. Also cleared to 0 when CSIE0 = 0.
-----	------	--

R	RELD	Bus Release Detection
Clear Conditions (RELD = 0)		Set Conditions (RELD = 1)
<ul style="list-style-type: none"> • When transfer start instruction is executed • If SIO0 and SVA values do not match in address reception • When CSIE0 = 0 • When RESET input is applied 		<ul style="list-style-type: none"> • When bus release signal (REL) is detected

R	CMDD	Command Detection
Clear Conditions (CMDD = 0)		Set Conditions (CMDD = 1)
<ul style="list-style-type: none"> • When transfer start instruction is executed • When bus release signal (REL) is detected • When CSIE0 = 0 • When RESET input is applied 		<ul style="list-style-type: none"> • When command signal (CMD) is detected

R/W	ACKT	Acknowledge signal is output in synchronization with the falling edge clock of SCK0 just after execution of the instruction to be set to 1, and after acknowledge signal output, automatically cleared to 0. Used as ACE=0. Also cleared to 0 upon start of serial interface transfer or when CSIE0 = 0.
-----	------	---

Note Bits 2, 3, and 6 (RELD, CMDD and ACKD) are read-only bits.

Remark Bits 0, 1, and 4 (RELD, CMDT, and ACKT) are 0 when read after data setting.

Figure 15-5. Serial Bus Interface Control Register Format (2/2)

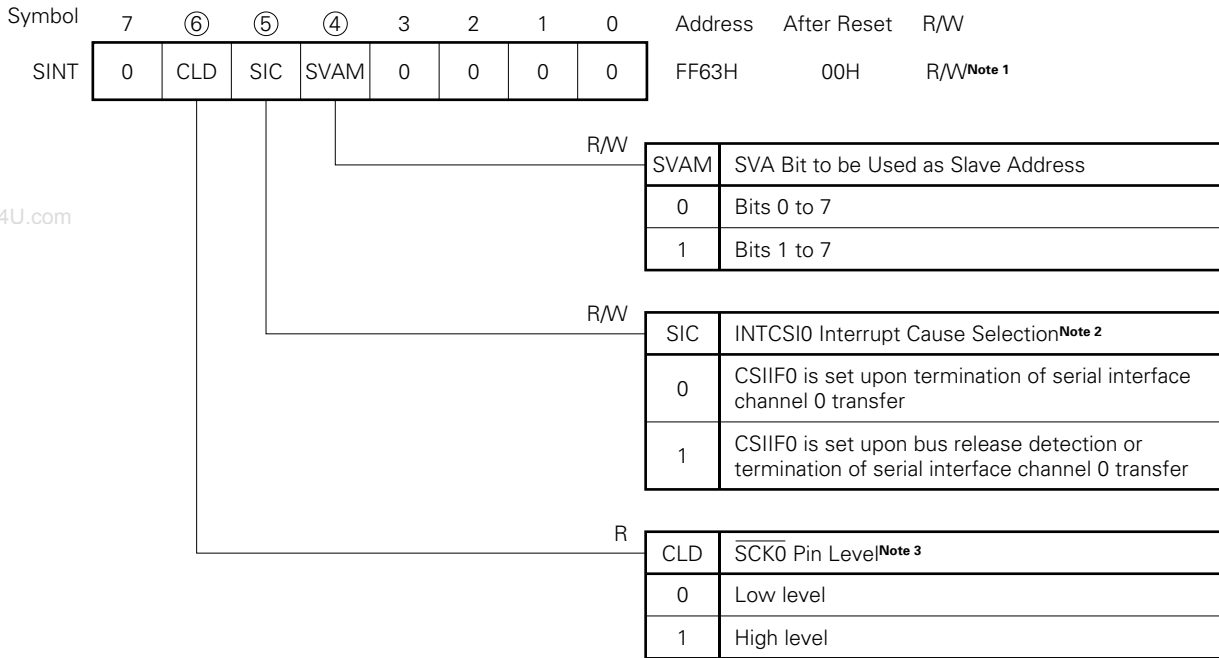
R/W	ACKE	Acknowledge Signal Output Control	
	0	Acknowledge signal automatic output disable (output with ACKT enable)	
	1	Before completion of transfer	Acknowledge signal is output in synchronization with the 9th clock falling edge of SCK0 (automatically output when ACKE = 1).
After completion of transfer		Acknowledge signal is output in synchronization with the falling edge of SCK0 just after execution of the instruction to be set to 1 (automatically output when ACKE = 1). However, not automatically cleared to 0 after acknowledge signal output.	
R	ACKD	Acknowledge Detection	
	Clear Conditions (ACKD = 0)		Set Conditions (ACKD = 1)
	<ul style="list-style-type: none"> Falling edge of the SCK0 immediately after the busy mode is released while executing the transfer start instruction When CSIE0 = 0 When RESET input is applied 		<ul style="list-style-type: none"> When acknowledge signal (ACK) is detected at the rising edge of SCK0 clock after completion of transfer
R/W	Note BSYE	Synchronizing Busy Signal Output Control	
	0	Disables busy signal which is output in synchronization with the falling edge of SCK0 clock just after execution of the instruction to be cleared to 0.	
	1	Outputs busy signal at the falling edge of SCK0 clock following the acknowledge signal.	

Note The busy mode can be canceled by start of serial interface transfer or reception of address signal. However, the BSYE flag is not cleared to 0.

(4) Interrupt timing specify register (SINT)

This register sets the bus release interrupt and address mask functions and displays the $\overline{\text{SCK0}}$ pin level status. SINT is set with a 1-bit or 8-bit memory manipulation instruction. $\overline{\text{RESET}}$ input sets SINT to 00H.

Figure 15-6. Interrupt Timing Specify Register Format



- Notes**
1. Bit 6 (CLD) is a read-only bit.
 2. When using wake-up function in the SBI mode, set SIC to 0.
 3. When CSIE0 = 0, CLD becomes 0.

Caution Be sure to set bit 0 to bit 3 to 0.

Remark SVA : Slave address register

15.4 Serial Interface Channel 0 Operations

The following four operating modes are available to the serial interface channel 0.

- Operation stop mode
- 3-wire serial I/O mode
- SBI mode
- 2-wire serial I/O mode

15.4.1 Operation stop mode

Serial transfer is not carried out in the operation stop mode. Thus, power consumption can be reduced. The serial I/O shift register 0 (SIO0) does not carry out shift operation either and thus it can be used as ordinary 8-bit register.

In the operation stop mode, the P25/SI0/SB0, P26/SO0/SB1 and P27/ $\overline{\text{SCK0}}$ pins can be used as ordinary input/output ports.

(1) Register setting

The operation stop mode is set with the serial operating mode register 0 (CSIM0).

CSIM0 is set with a 1-bit or 8-bit memory manipulation instruction.

$\overline{\text{RESET}}$ input sets CSIM0 to 00H.

The shaded area is used in the operation stop mode.

Symbol	⑦	⑥	⑤	4	3	2	1	0	Address	After Reset	R/W
CSIM0	CSIE0	COI	WUP	CSIM04	CSIM03	CSIM02	CSIM01	CSIM00	FF60H	00H	R/W

R/W	CSIE0	Serial Interface Channel 0 Operation Control
	0	Operation stopped
	1	Operation enabled

15.4.2 3-wire serial I/O mode operation

The 3-wire serial I/O mode is valid for connection of peripheral I/O units and display controllers which incorporate a conventional synchronous clocked serial interface as is the case with the 75X, 78K, and 17K series.

Communication is carried out with three lines of serial clock ($\overline{\text{SCK0}}$), serial output (SO0), and serial input (SI0).

(1) Register setting

The 3-wire serial I/O mode is set with the serial operating mode register 0 (CSIM0) and serial bus interface control register (SBIC).

✳

(a) Serial operating mode register 0 (CSIM0)

CSIM0 is set with a 1-bit or 8-bit memory manipulation instruction.

$\overline{\text{RESET}}$ input sets CSIM0 to 00H.

The shaded area is used in the 3-wire serial I/O mode.

www.DataSheet4U.com

Symbol	⑦	⑥	⑤	4	3	2	1	0	Address	After Reset	R/W
CSIM0	CSIE0	COI	WUP	CSIM04	CSIM03	CSIM02	CSIM01	CSIM00	FF60H	00H	R/W ^{Note 1}

R/W	CSIM01	CSIM00	Serial Interface Channel 0 Clock Selection
	0	×	Input Clock to SCK0 pin from off-chip
	1	0	8-bit timer register 2 (TM2) output
	1	1	Clock specified with bits 0 to 3 of timer clock select register 3 (TCL3)

R/W	CSIM04	CSIM03	CSIM02	PM25	P25	PM26	P26	PM27	P27	Operation Mode	Start Bit	SIO/SB0/P25 Pin Function	SO0/SB1/P26 Pin Function	SCK0/P27 Pin Function
	0	×	0	^{Note 2} 1	^{Note 2} ×	0	0	0	1	3-wire serial I/O mode	MSB LSB	SIO ^{Note 2} (Input)	SO0 (CMOS output)	SCK0 (CMOS input/output)
	1	0	SBI mode (See section 15.4.3, "SBI mode operation".)											
	1	1	2-wire serial I/O mode (See section 15.4.4, "2-wire serial I/O mode operation".)											

R/W	WUP	Wake-up Function Control ^{Note 3}
	0	Interrupt request signal generation with each serial transfer in any mode
	1	Interrupt request signal generation when the address received after bus release (when CMDD=RELD=1) matches the slave address register data in SBI mode

R/W	CSIE0	Serial Interface Channel 0 Operation Control
	0	Operation stopped
	1	Operation enabled

- Notes**
1. Bit 6 (COI) is a read-only bit.
 2. Can be used as P25 (CMOS input/output) when used only for transmission.
 3. Be sure to set WUP to 0 when the 3-wire serial I/O mode is selected.

Remark × : don't care

(b) Serial bus interface control register (SBIC)

SBIC is set with a 1-bit or 8-bit memory manipulation instruction.

$\overline{\text{RESET}}$ input sets SBIC to 00H.

The shaded area is used in the 3-wire serial I/O mode.

Symbol	⑦	⑥	⑤	④	③	②	①	①	Address	After Reset	R/W
SBIC	BSYE	ACKD	ACKE	ACKT	CMDD	RELD	CMDT	RELT	FF61H	00H	R/W

R/W	RELT	When RELT = 1, SO latch is set to 1. After SO latch setting, automatically cleared to 0. Also cleared to 0 when CSIE0 = 0.
-----	------	--

R/W	CMDT	When CMDT = 1, SO latch is cleared to 0. After SO latch clearance, automatically cleared to 0. Also cleared to 0 when CSIE0 = 0.
-----	------	--

www.DataSheet4U.com

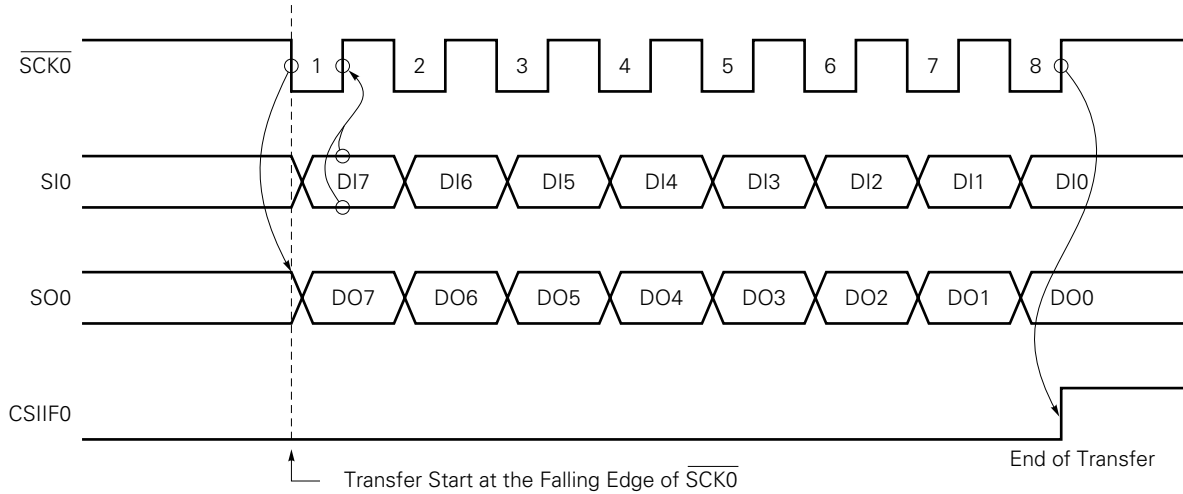
(2) Communication operation

The 3-wire serial I/O mode is used for data transmission/reception in 8-bit units. Bit-wise data transmission/reception is carried out in synchronization with the serial clock.

Shift operation of the serial I/O shift register 0 (SIO0) is carried out at the falling edge of the serial clock ($\overline{SCK0}$). The transmitted data is held in the SO0 latch and is output from the SO0 pin. The received data input to the SIO pin is latched in SIO0 at the rising edge of $\overline{SCK0}$.

Upon termination of 8-bit transfer, SIO0 operation stops automatically and the interrupt request flag (CSIF0) is set.

Figure 15-7. 3-Wire Serial I/O Mode Timings



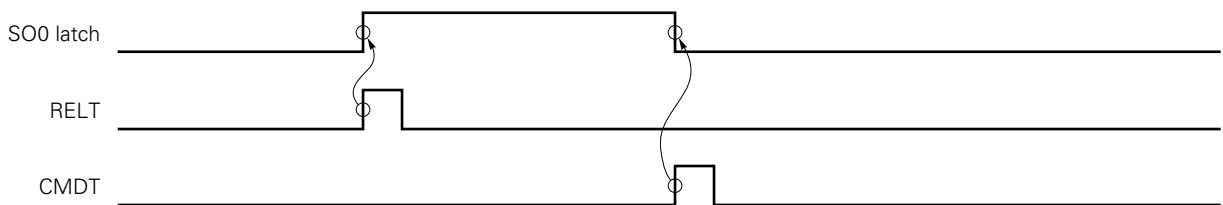
The SO0 pin is a CMOS output pin and outputs current SO0 latch statuses. Thus, the SO0 pin output status can be manipulated by setting the RELT and CMDT bits. However, do not carry out this manipulation during serial transfer.

Control the $\overline{SCK0}$ pin output level in the output mode (internal system clock mode) by manipulating the P27 output latch (refer to **15.4.5 $\overline{SCK0}$ /P27 pin output manipulation**).

(3) Other signals

Figure 15-8 shows RELT and CMDT operations.

Figure 15-8. RELT and CMDT Operations



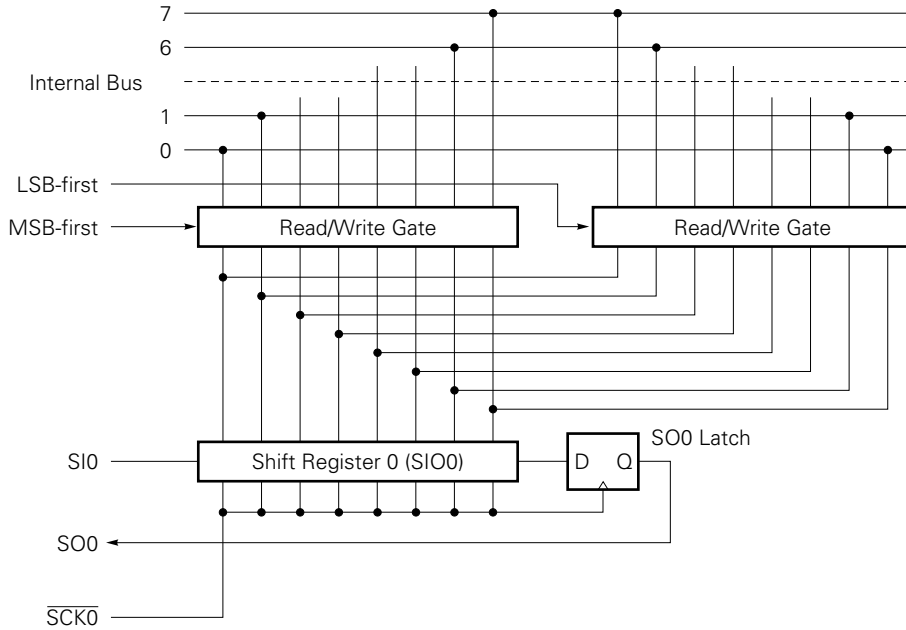
(4) MSB/LSB switching as the start bit

The 3-wire serial I/O mode enables to select transfer to start from MSB or LSB.

Figure 15-9 shows the configuration of the serial I/O shift register 0 (SIO0) and internal bus. As shown in the figure, MSB/LSB can be read/written in reverse form.

MSB/LSB switching as the start bit can be specified with bit 2 (CSIM02) of the serial operating mode register 0 (CSIM0).

Figure 15-9. Circuit of Switching in Transfer Bit Order



Start bit switching is realized by switching the bit order for data write to SIO0. The SIO0 shift order remains unchanged.

Thus, switching between MSB-first and LSB-first must be performed before writing data to the shift register.

(5) Transfer start

Serial transfer is started by setting transfer data to the serial I/O shift register 0 (SIO0) when the following two conditions are satisfied.

- Serial interface channel 0 operation control bit (CSIE0) = 1.
- Internal serial clock is stopped or $\overline{\text{SCK0}}$ is a high level after 8-bit serial transfer.

Caution If CSIE0 is set to "1" after data write to SIO0, transfer does not start.

Upon termination of 8-bit transfer, serial transfer automatically stops and the interrupt request flag (CSIF0) is set.

15.4.3 SBI mode operation

SBI (Serial Bus Interface) is a high-speed serial interface in compliance with the NEC serial bus format.

SBI uses a single master device and employs the clocked serial I/O format with the addition of a bus configuration function. This function enables devices to communicate using only two lines. Thus, when making up a serial bus with two or more microcontrollers and peripheral ICs, the number of ports to be used and the number of wires on the board can be decreased.

The master device outputs three kinds of data to slave devices on the serial data bus: "addresses" to select a device to be communicated with, "commands" to instruct the selected device, and "data" which is actually required.

The slave device can identify the received data into "address", "command", or "data", by hardware. This function enables the application program serial interface (channel 0) control portions to be simplified.

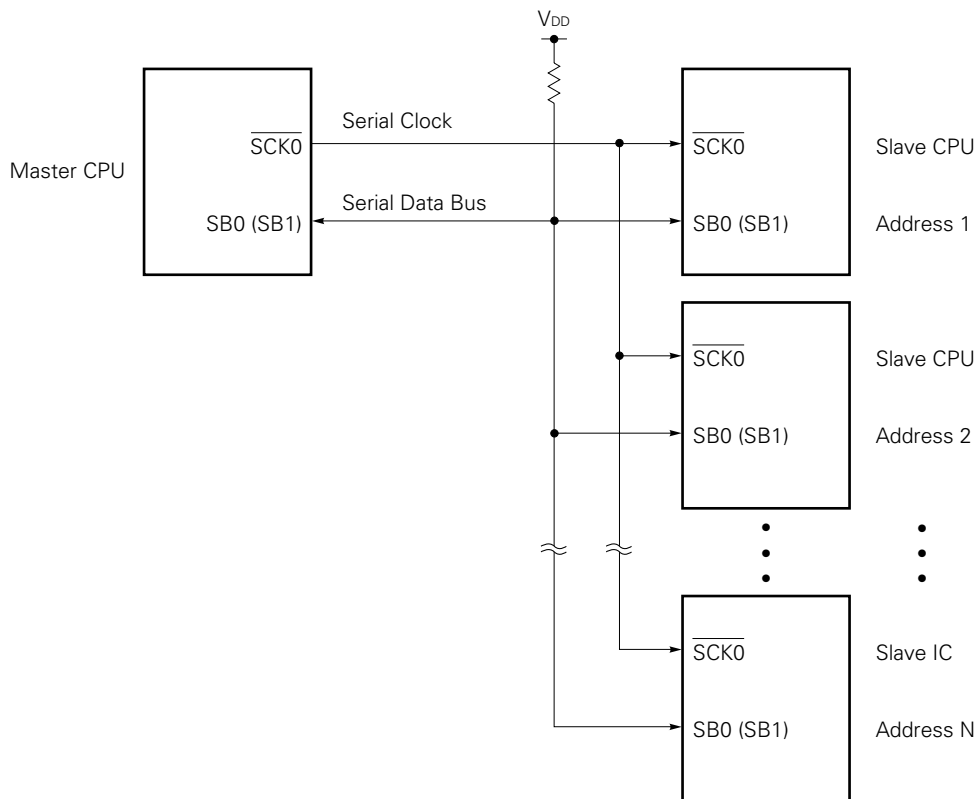
The SBI function is incorporated into various devices including 75X-series devices and 78K-series 8-bit and 16-bit single-chip microcontrollers.

Figure 15-10 shows a serial bus configuration example when a CPU having a serial interface compliant with SBI and peripheral ICs are used.

In SBI, the SB0 (SB1) serial data bus pin is an open-drain output pin and therefore the serial data bus line behaves in the same way as the wired-OR configuration. In addition, a pull-up resistor must be connected to the serial data bus line.

When the SBI mode is used, refer to **(10) SBI mode precautions (d)** described later.

Figure 15-10. Example of Serial Bus Configuration with SBI



Caution When exchanging the master CPU/slave CPU, a pull-up resistor is necessary for the serial clock line ($\overline{\text{SCK0}}$) as well because serial clock line ($\overline{\text{SCK0}}$) input/output switching is carried out asynchronously between the master and slave CPUs.

(1) SBI functions

In the conventional serial I/O format, when a serial bus is configured by connecting two or more devices, many ports and wiring are necessary, to provide chip select signal to identify command and data, and to judge the busy state, because only the data transfer function is available. If these operations are to be controlled by software, the software must be heavily loaded.

In SBI, a serial bus can be configured with two signal lines of serial clock $\overline{\text{SCK0}}$ and serial data bus SB0 (SB1). Thus, use of SBI leads to reduction in the number of microcontroller ports and that of wirings and routings on the board.

The SBI functions are described below.

(a) Address/command/data identify function

Serial data is distinguished into addresses, commands, and data.

www.DataSheet4U.com

(b) Chip select function by address transmission

The master executes slave chip selection by address transmission.

(c) Wake-up function

The slave can easily judge address reception (chip select judgment) with the wake-up function (which can be set/reset by software).

When the wake-up function is set, the interrupt request signal (INTCSI0) is generated upon reception of a match address.

Thus, when communication is executed with two or more devices, the CPU except the selected slave devices can operate regardless of underway serial communications.

(d) Acknowledge signal ($\overline{\text{ACK}}$) control function

The acknowledge signal to check serial data reception is controlled.

(e) Busy signal ($\overline{\text{BUSY}}$) control function

The busy signal to report the slave busy state is controlled.

(2) SBI definition

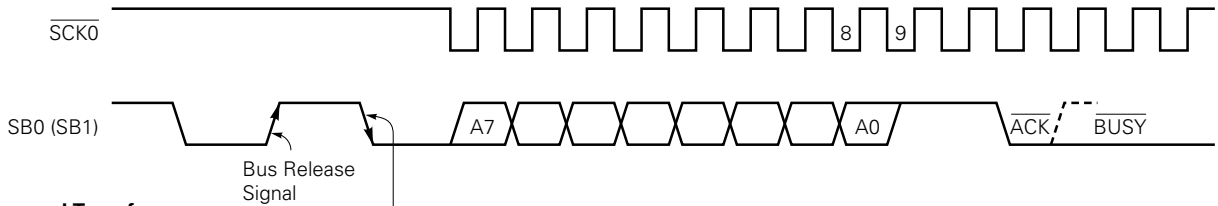
The SBI serial data format and the signals to be used are defined as follows.

Serial data to be transferred with SBI consists of three kinds of data: "address", "command", and "data".

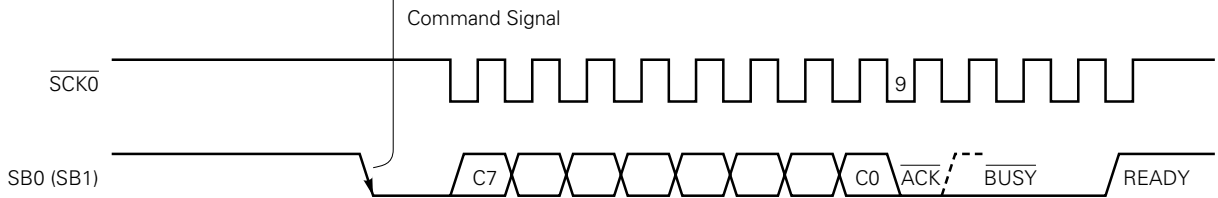
Figure 15-11 shows the address, command, and data transfer timings.

Figure 15-11. SBI Transfer Timings

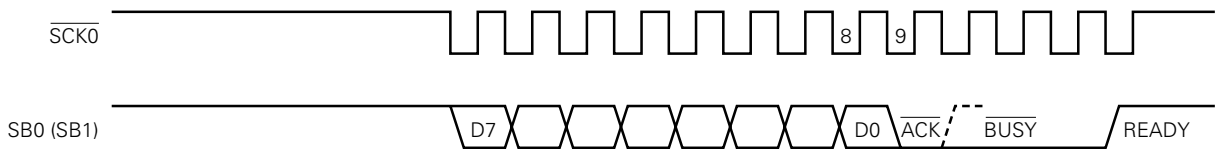
Address Transfer



Command Transfer



Data Transfer



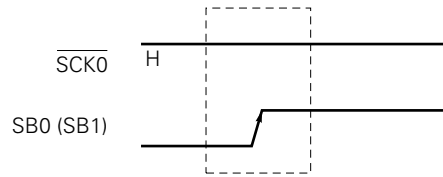
The bus release signal and the command signal are output by the master device. $\overline{\text{BUSY}}$ is output by the slave signal. $\overline{\text{ACK}}$ can be output by either the master or slave device (normally, the 8-bit data receiver outputs). Serial clocks continue to be output by the master device from 8-bit data transfer start to $\overline{\text{BUSY}}$ reset.

(a) Bus release signal (REL)

The bus release signal is a signal with the SB0 (SB1) line which has changed from the low level to the high level when the $\overline{\text{SCK0}}$ line is at the high level (without serial clock output).

This signal is output by the master device.

Figure 15-12. Bus Release Signal



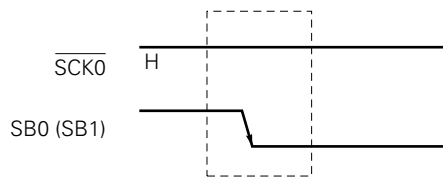
www.DataSheet4U.com

The bus release signal indicates that the master device is going to transmit an address to the slave device. The slave device incorporates hardware to detect the bus release signal.

(b) Command signal (CMD)

The command signal is a signal with the SB0 (SB1) line which has changed from the high level to the low level when the $\overline{\text{SCK0}}$ line is at the high level (without serial clock output). This signal is output by the master device.

Figure 15-13. Command Signal

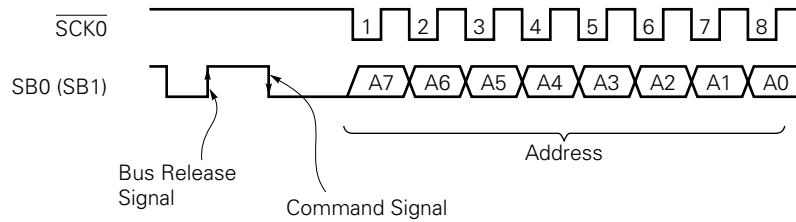


The slave device incorporates hardware to detect the command signal.

(c) Address

An address is 8-bit data which the master device outputs to the slave device connected to the bus line in order to select a particular slave device.

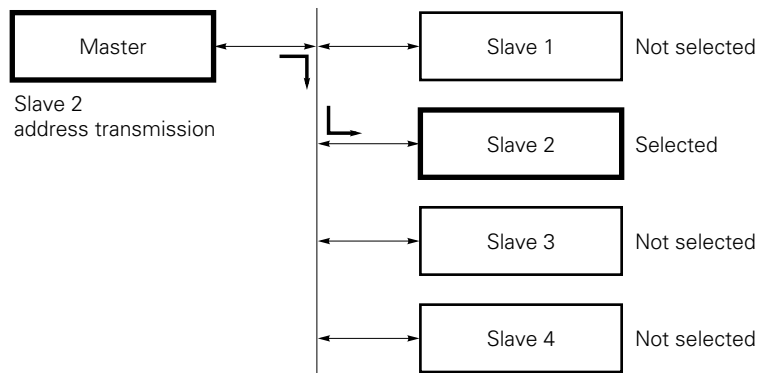
Figure 15-14. Addresses



www.DataSheet4U.com

8-bit data following bus release and command signals is defined as an "address". In the slave device, this condition is detected by hardware and whether or not 8-bit data matches the own specification number (slave address) is checked by hardware. If the 8-bit data matches the slave address, the slave device has been selected. After that, communication with the master device continues until a release instruction is received from the master device.

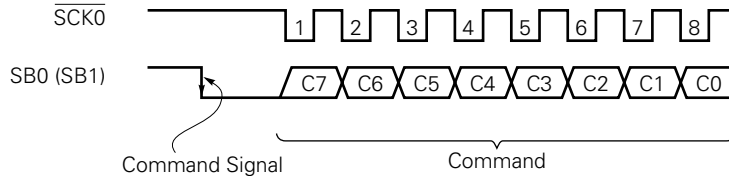
Figure 15-15. Slave Selection with Address



(d) Command and data

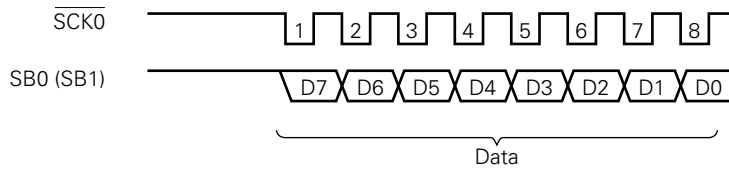
The master device transmits commands to, and transmits/receives data to/from the slave device selected by address transmission.

Figure 15-16. Commands



www.DataSheet4U.com

Figure 15-17. Data



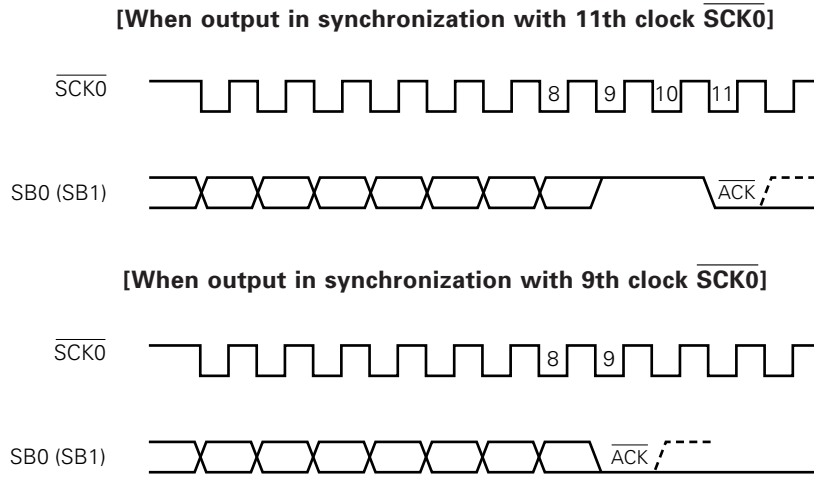
8-bit data following a command signal is defined as "command" data. 8-bit data without command signal is defined as "data". Command and data operation procedures are allowed to determine by user according to communications specifications.

(e) Acknowledge signal ($\overline{\text{ACK}}$)

The acknowledge signal is used to check serial data reception between transmitter and receiver.

Figure 15-18. Acknowledge Signal

*



The acknowledge signal is one-shot pulse to be generated at the falling edge of $\overline{\text{SCK0}}$ after 8-bit data transfer. It can be positioned anywhere and can be synchronized with any clock $\overline{\text{SCK0}}$.

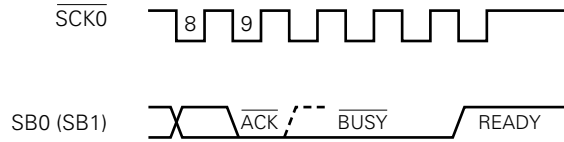
After 8-bit data transmission, the transmitter checks whether the receiver has returned the acknowledge signal. If the acknowledge signal is not returned for the preset period of time after data transmission, it can be judged that data reception has not been carried out correctly.

(f) Busy signal ($\overline{\text{BUSY}}$) and ready signal (READY)

The $\overline{\text{BUSY}}$ signal is intended to report to the master device that the slave device is preparing for data transmission/reception.

The READY signal is intended to report to the master device that the slave device is ready for data transmission/reception.

Figure 15-19. $\overline{\text{BUSY}}$ and READY Signals



www.DataSheet4U

In SBI, the slave device notifies the master device of the busy state by setting SB0 (SB1) line to the low level.

The $\overline{\text{BUSY}}$ signal output follows the acknowledge signal output from the master or slave device. It is set/reset at the falling edge of $\overline{\text{SCK0}}$. When the $\overline{\text{BUSY}}$ signal is reset, the master device automatically terminates the output of $\overline{\text{SCK0}}$ serial clock.

When the $\overline{\text{BUSY}}$ signal is reset and the READY signal is set, the master device can start the next transfer.

(3) Register setting

The SBI mode is set with the serial operating mode register 0 (CSIM0), the serial bus interface control register (SBIC), and the interrupt timing specify register (SINT).

(a) Serial operating mode register 0 (CSIM0)

CSIM0 is set with a 1-bit or 8-bit memory manipulation instruction.

RESET input sets CSIM0 to 00H.

The shaded area is used in the SBI mode.

*

Symbol	⑦	⑥	⑤	4	3	2	1	0	Address	After Reset	R/W
CSIM0	CSIE0	COI	WUP	CSIM04	CSIM03	CSIM02	CSIM01	CSIM00	FF60H	00H	R/W ^{Note 1}

www.DataSheet4U.com

R/W	CSIM01	CSIM00	Serial Interface Channel 0 Clock Selection
	0	×	Input Clock to SCK0 pin from off-chip
	1	0	8-bit timer register 2 (TM2) output
	1	1	Clock specified with bits 0 to 3 of timer clock select register 3 (TCL3)

R/W	CSIM04	CSIM03	CSIM02	PM25	P25	PM26	P26	PM27	P27	Operation Mode	Start Bit	SI0/SB0/P25 Pin Function	SO0/SB1/P26 Pin Function	SCK0/P27 Pin Function		
	0	×	3-wire serial I/O mode (15.4.2, "3-wire serial I/O mode operation.")													
	1	0	Note 2 Note 2		0	×	×	0	0	0	1	SBI mode	MSB	P25 (CMOS input/output)	SB1 (N-ch open-drain input/output)	SCK0 (CMOS input/output)
			Note 2 Note 2		1	0	0	×	×	0	1			SB0 (N-ch open-drain input/output)	P26 (CMOS input/output)	
	1	1	2-wire serial I/O mode (see section 15.4.4, "2-wire serial I/O mode operation.")													

R/W	WUP	Wake-up Function Control
	0	Interrupt request signal generation with each serial transfer in any mode
	1	Interrupt request signal generation when the address received after bus release (when CMDD=RELD=1) matches the slave address register data in SBI mode

R	COI	Slave Address Comparison Result Flag ^{Note3}
	0	Slave address register not equal to serial I/O shift register 0 data
	1	Slave address register equal to serial I/O shift register 0 data

R/W	CSIE0	Serial Interface Channel 0 Operation Control
	0	Operation stopped
	1	Operation enabled

- Notes**
1. Bit 6 (COI) is a read-only bit.
 2. Can be used as a port.
 3. When CSIE0=0, COI becomes 0.

Remark × : don't care

(b) Serial bus interface control register (SBIC)

SBIC is set with a 1-bit or 8-bit memory manipulation instruction.

$\overline{\text{RESET}}$ input sets SBIC to 00H.

The shaded area is used in the SBI mode.

Symbol	⑦	⑥	⑤	④	③	②	①	①	Address	After Reset	R/W
SBIC	BSYE	ACKD	ACKE	ACKT	CMDD	RELD	CMDT	RELT	FF61H	00H	R/W ^{Note}

R/W	RELT	Used for bus release signal output. When RELT = 1, SO latch is set to (1). After SO latch setting, automatically cleared to (0). Also cleared to 0 when CSIE0 = 0.
-----	------	--

R/W	CMDT	Used for command signal output. When CMDT = 1, SO latch is cleared to (0). After SO latch clearance, automatically cleared to (0). Also cleared to 0 when CSIE0 = 0.
-----	------	--

R	RELD	Bus Release Detection
Clear Conditions (RELD = 0)		Set Conditions (RELD = 1)
<ul style="list-style-type: none"> When transfer start instruction is executed If SIO0 and SVA values do not match in address reception When $\overline{\text{CSIE0}} = 0$ When $\overline{\text{RESET}}$ input is applied 		<ul style="list-style-type: none"> When bus release signal (REL) is detected

R	CMDD	Command Detection
Clear Conditions (CMDD = 0)		Set Conditions (CMDD = 1)
<ul style="list-style-type: none"> When transfer start instruction is executed When bus release signal (REL) is detected When $\overline{\text{CSIE0}} = 0$ When $\overline{\text{RESET}}$ input is applied 		<ul style="list-style-type: none"> When command signal (CMD) is detected

R/W	ACKT	Acknowledge signal is output in synchronization with the falling edge clock of $\overline{\text{SCK0}}$ just after execution of the instruction to be set to (1) and, after acknowledge signal output, automatically cleared to (0). Used as ACKE=0. Also cleared to (0) upon start of serial interface transfer or when CSIE0 = 0.
-----	------	---

R/W	ACKE	Acknowledge Signal Output Control
0		Acknowledge signal automatic output disable (output with ACKT enable)
1	Before completion of transfer	Acknowledge signal is output in synchronization with the 9th clock falling edge of $\overline{\text{SCK0}}$ (automatically output when ACKE = 1).
	After completion of transfer	Acknowledge signal is output in synchronization with falling edge clock of $\overline{\text{SCK0}}$ just after execution of the instruction to be set to 1 (automatically output when ACKE = 1). However, not automatically cleared to 0 after acknowledge signal output.

(Continued)

Note Bits 2, 3, and 6 (RELD, CMDD and ACKD) are read-only bits.

Remark Bits 0, 1, and 4 (RELT, CMDT, and ACKT) are 0 when read after data setting.

R	ACKD	Acknowledge Detection	
		Clear Conditions (ACKD = 0)	Set Conditions (ACKD = 1)
		<ul style="list-style-type: none"> • $\overline{SCK0}$ fall immediately after the busy mode is released during the transfer start instruction execution. • When CSIE0 = 0 • When \overline{RESET} input is applied 	<ul style="list-style-type: none"> • When acknowledge signal \overline{ACK} is detected at the rising edge of $\overline{SCK0}$ clock after completion of transfer

*

R/W	Note	Synchronizing Busy Signal Output Control	
	BSYE		
	0	Disables busy signal which is output in synchronization with the falling edge of $\overline{SCK0}$ clock just after execution of the instruction to be cleared to (0).	
1	Outputs busy signal at the falling edge of $\overline{SCK0}$ clock following the acknowledge signal.		

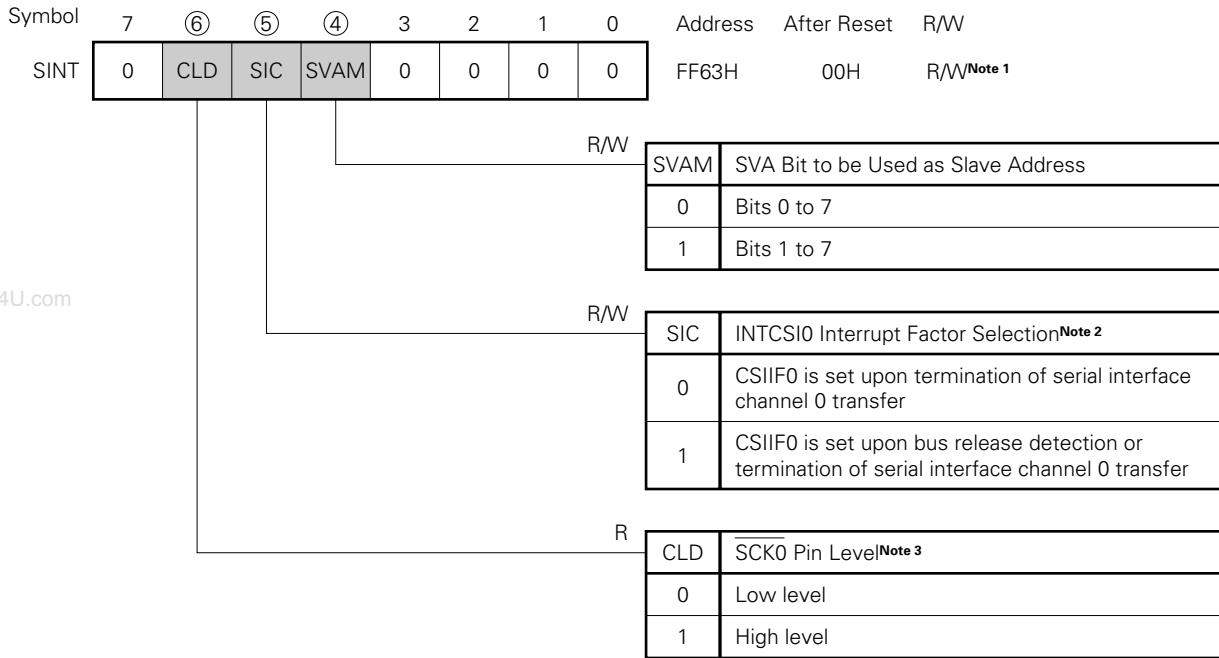
Note Busy mode can be cleared by start of serial interface transfer or reception of address signal. However, BSYE flag is not cleared to 0.

(c) Interrupt timing specify register (SINT)

SINT is set with a 1-bit or 8-bit memory manipulation instruction.

$\overline{\text{RESET}}$ input sets SINT to 00H.

The shaded area is used in the SBI mode.



www.DataSheet4U.com

- Notes**
1. Bit 6 (CLD) is a read-only bit.
 2. When using wake-up function in the SBI mode, set SIC to 0.
 3. When CSIE0 = 0, CLD becomes 0.

Caution Be sure to set bit 0 to bit 3 to 0.

Remark SVA : Slave address register

(4) Various signals

Figures 15-20 to 15-25 show various signals and flag operations in SBI. Table 15-3 lists various signals in SBI.

Figure 15-20. RELT, CMDT, RELD, and CMDD Operations (Master)

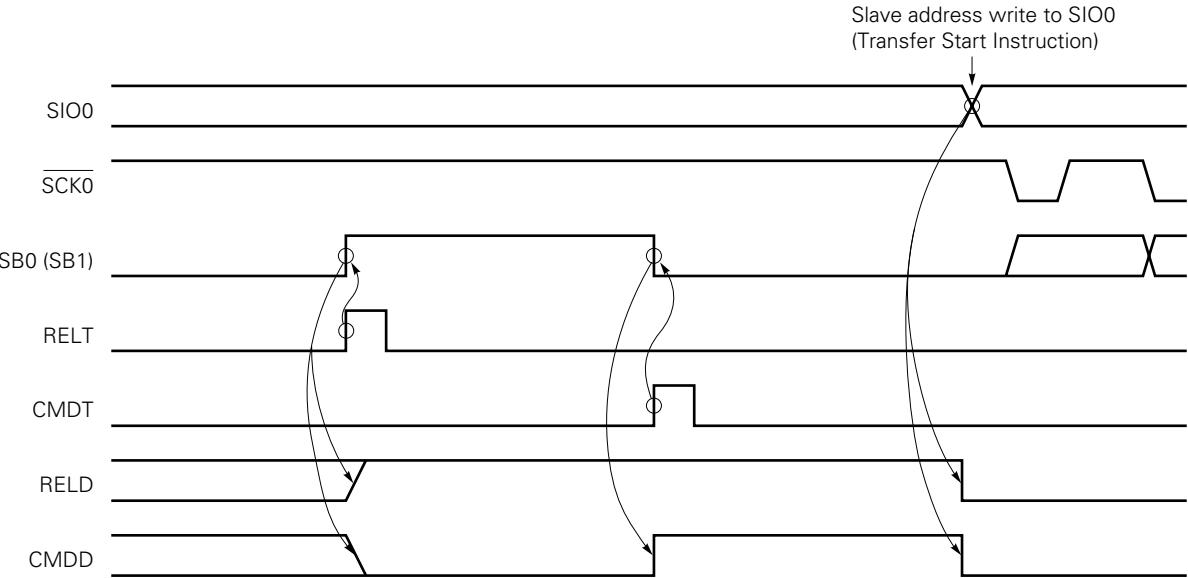
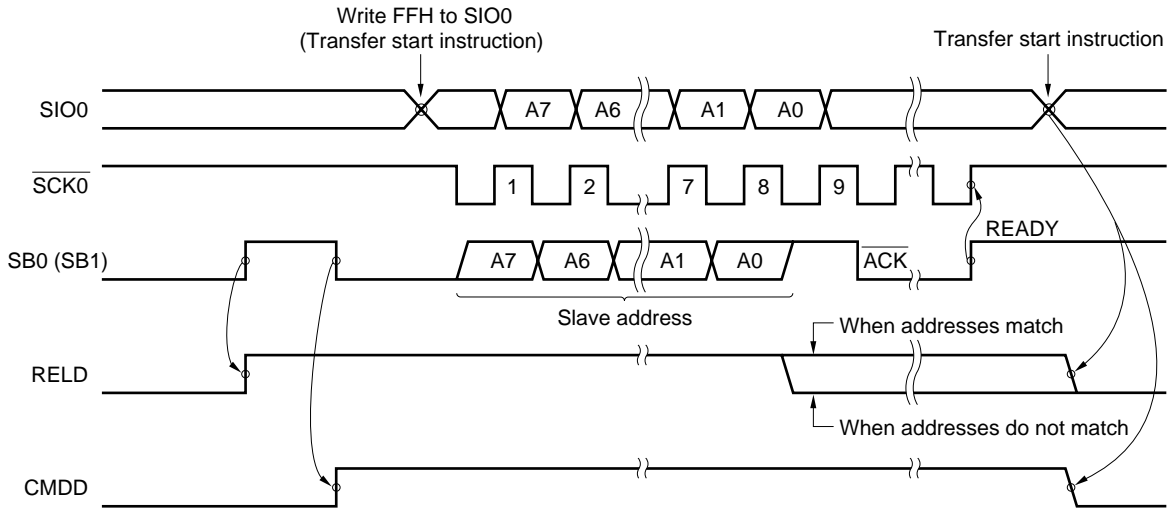
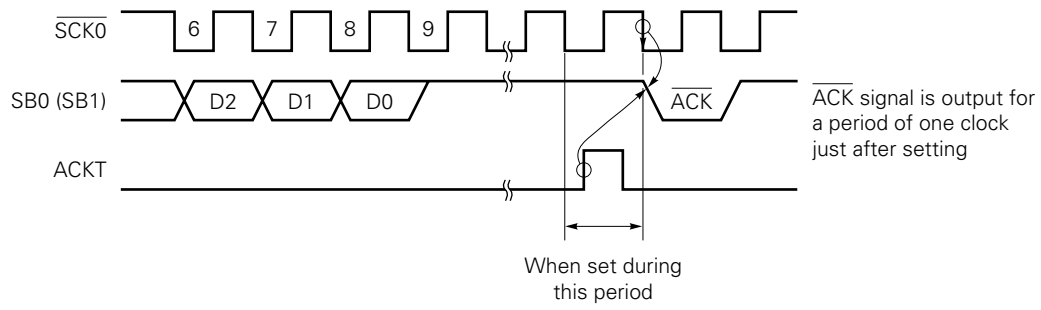


Figure 15-21. RELD and CMDD Operations (Slave)



*

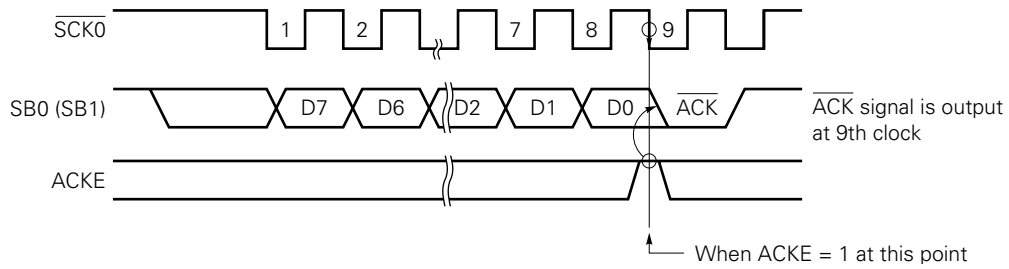
Figure 15-22. ACKT Operation



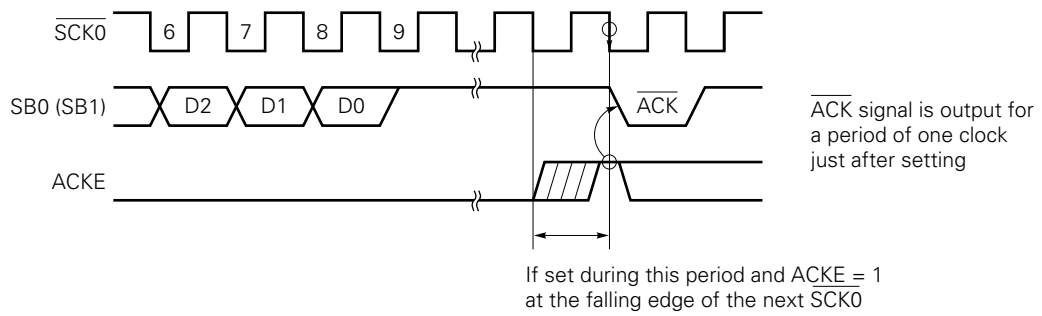
Caution Do not set ACKT before termination of transfer.

Figure 15-23. ACKE Operations

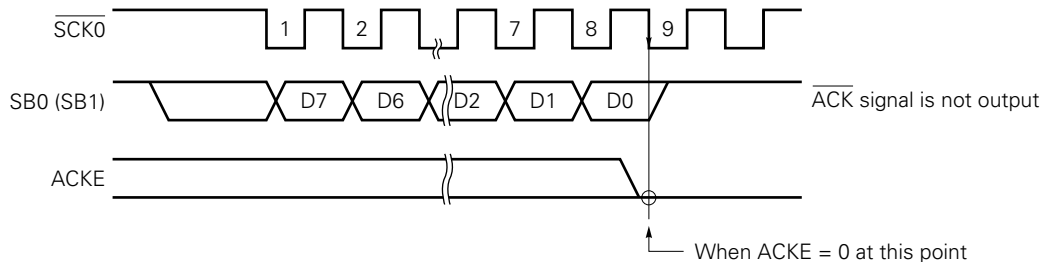
(a) When ACKE = 1 upon completion of transfer



(b) When set after completion of transfer



(c) When ACKE = 0 upon completion of transfer



(d) When "ACKE = 1" period is short

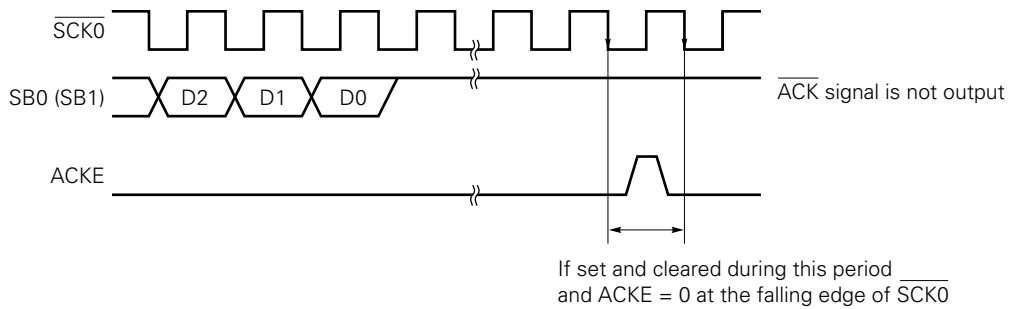


Figure 15-24. ACKD Operations

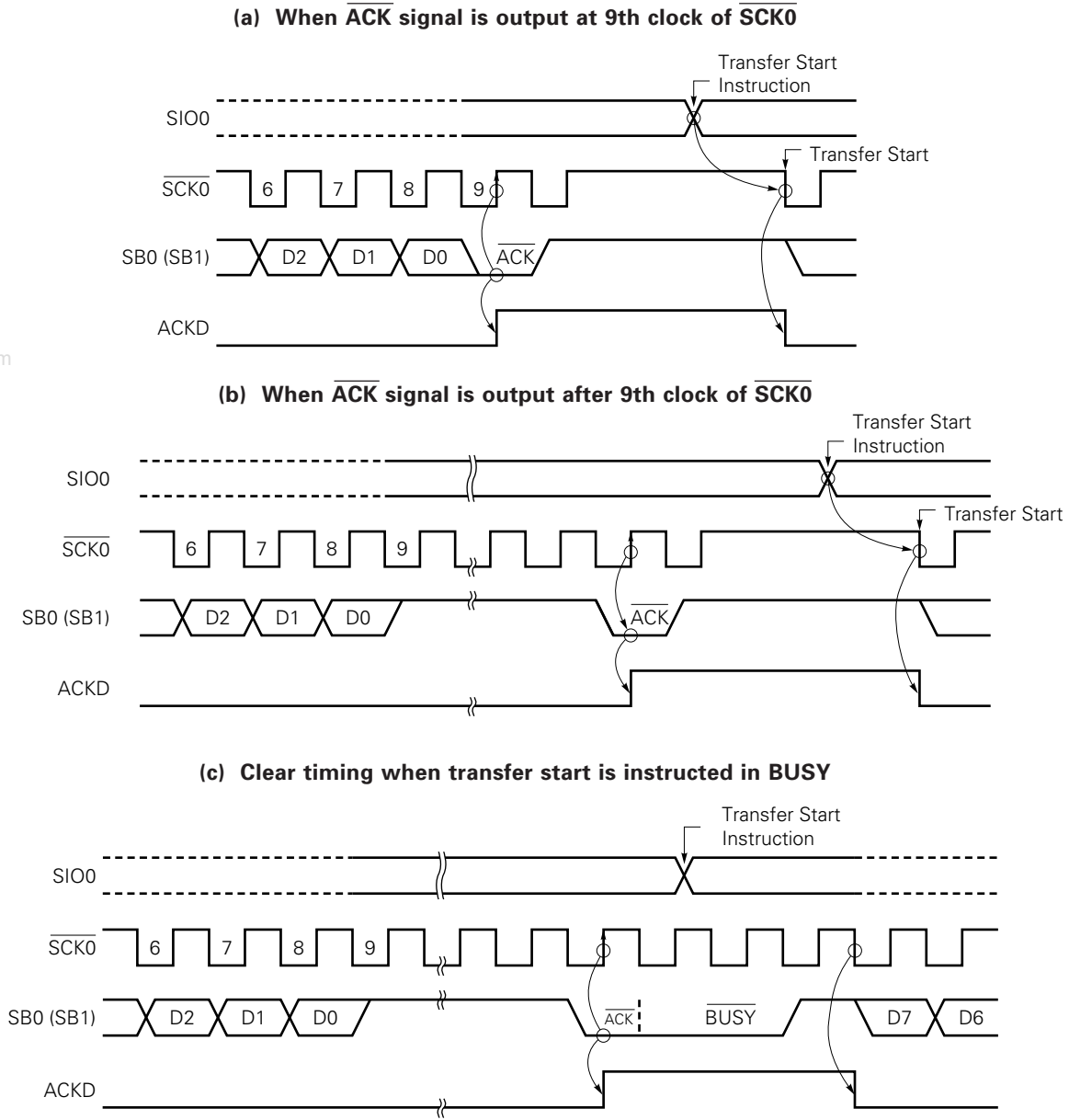


Figure 15-25. BSYE Operation

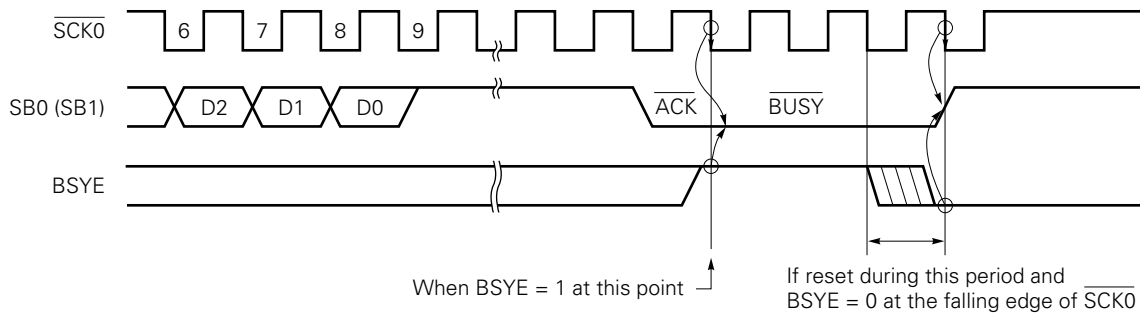


Table 15-3. Various Signals in SBI Mode (1/2)

Signal Name	Output Device	Definition	Timing Chart	Output Condition	Effects on Flag	Meaning of Signal
Bus release signal (REL)	Master	SB0 (SB1) rising edge when $\overline{SCK0} = 1$		<ul style="list-style-type: none"> • RELT set 	<ul style="list-style-type: none"> • RELD set • CMDD clear 	CMD signal is output to indicate that transmit data is an address.
Command signal (CMD)	Master	SB0 (SB1) falling edge when $\overline{SCK0} = 1$		<ul style="list-style-type: none"> • CMDT set 	<ul style="list-style-type: none"> • CMDD set 	i) Transmit data is an address after REL signal output. ii) REL signal is not output and transmit data is an command.
Acknowledge signal (\overline{ACK})	Master/slave	Low-level signal to be output to SB0 (SB1) during one-clock period of $\overline{SCK0}$ after completion of serial reception	[Synchronous BUSY output]	① $\overline{ACKE} = 1$ ② \overline{ACKT} set	<ul style="list-style-type: none"> • ACKD set 	Completion of reception
Busy signal (\overline{BUSY})	Slave	[Synchronous BUSY signal] Low-level signal to be output to SB0 (SB1) following Acknowledge signal		<ul style="list-style-type: none"> • BSYE = 1 	—	Serial receive disable because of processing
Ready signal (READY)	Slave	High-level signal to be output to SB0 (SB1) before serial transfer start and after completion of serial transfer		① $\overline{BSYE} = 0$ ② Execution of instruction for data write to SIO0 (transfer start instruction) ③ Address signal reception	—	Serial receive enable

Table 15-3. Various Signals in SBI Mode (2/2)

Signal Name	Output Device	Definition	Timing Chart	Output Condition	Effects on Flag	Meaning of Signal
Serial clock (SCK0)	Master	Synchronous clock to output address/command/data, $\overline{\text{ACK}}$ signal, synchronous $\overline{\text{BUSY}}$ signal, etc. Address/command/data are transferred with the first eight synchronous clocks.				Timing of signal output to serial data bus
Address (A7 to A0)	Master	8-bit data to be transferred in synchronization with $\overline{\text{SCK0}}$ after output of REL and CMD signals		When CSIE0 = 1, execution of instruction for data write to SIO0 (serial transfer start instruction) ^{Note 2}	CSIIF0 set (rising edge of 9th clock of $\overline{\text{SCK0}}$) ^{Note 1}	Address value of slave device on the serial bus
Commands (C7 to C0)	Master	8-bit data to be transferred in synchronization with $\overline{\text{SCK0}}$ after output of only CMD signal without REL signal output				Instructions and messages to the slave device
Data (D7 to D0)	Master/slave	8-bit data to be transferred in synchronization with $\overline{\text{SCK0}}$ without output of REL and CMD signals				Numeric values to be processed with slave or master device

Notes 1. When WUP = 0, CSIIF0 is set at the rising edge of the 9th clock of $\overline{\text{SCK0}}$.

When WUP = 1, an address is received. Only when the address matches the slave address register (SVA) value, CSIIF0 is set.

2. In $\overline{\text{BUSY}}$ state, transfer starts after the READY state is set.

(5) Pin configuration

The serial clock pin ($\overline{SCK0}$) and serial data bus pin SB0 (SB1) have the following configurations.

(a) $\overline{SCK0}$ Serial clock input/output pin

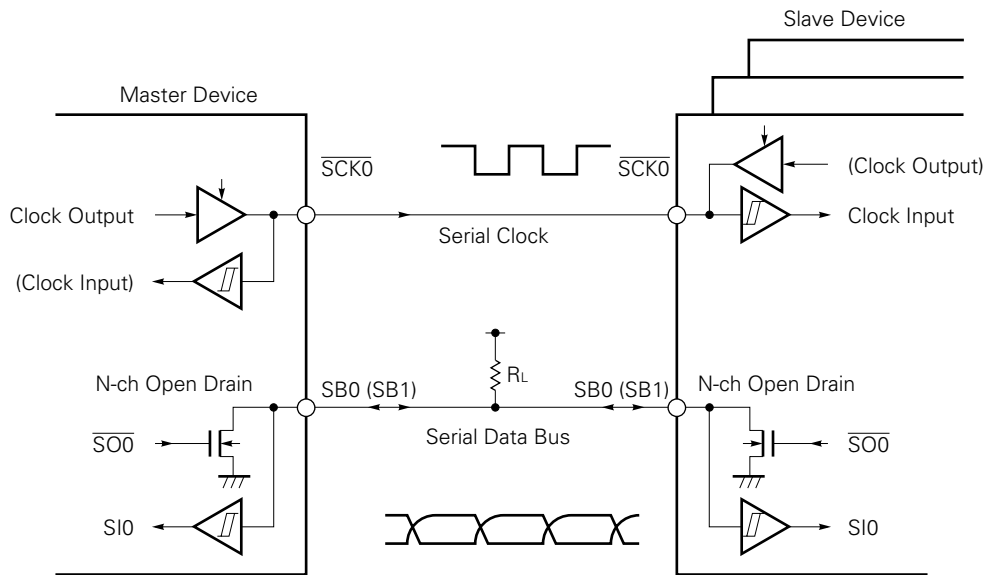
- ① Master ... CMOS and push-pull output
- ② Slave Schmitt input

(b) SB0 (SB1) Serial data input/output dual-function pin

Both master and slave devices have an N-ch open drain output and a Schmitt input.

Because the serial data bus line has an N-ch open-drain output, an external pull-up resistor is necessary.

Figure 15-26. Pin Configuration



Caution Because the N-ch open-drain must be turned off at time of data reception, write FFH to SIO0 in advance. The N-ch open-drain can be turned off at any time of transfer. However, when the wake-up function specify bit (WUP) = 1, the N-ch transistor is always turned off. Thus, it is not necessary to write FFH to SIO0.

(6) Address match detection method

In the SBI mode, a particular slave device is selected by address communication from the master device and communication is started.

Address match detection is executed by hardware. With the slave address register (SVA), CSIF0 is set in the wake-up state (WUP = 1) only when the address transmitted from the master device matches the value set to SVA.

Cautions 1. Slave selection/non-selection is detected by matching of the slave address received after bus release (RELD = 1).

For this match detection, match interrupt (INTCSI0) of the address to be generated with WUP = 1 is normally used. Thus, execute selection/non-selection detection by slave address when WUP = 1.

2. When detecting selection/non-selection without the use of interrupt with WUP = 0, do so by means of transmission/reception of the command preset by program instead of using the address match detection method.

(7) Error detection

In the SBI mode, the serial bus SB0 (SB1) status being transmitted is fetched into the destination device, that is, the serial I/O shift register 0 (SIO0). Thus, transmit errors can be detected in the following way.

(a) Method of comparing SIO0 data before transmission to that after transmission

In this case, if two data differ from each other, a transmit error is judged to have occurred.

(b) Method of using the slave address register (SVA)

Transmit data is set to both SIO0 and SVA and is transmitted. After termination of transmission, COI bit (match signal coming from the address comparator) of the serial operating mode register 0 (CSIM0) is tested. If "1", normal transmission is judged to have been carried out. If "0", a transmit error is judged to have occurred.

(8) Communication operation

In the SBI mode, the master device selects normally one slave device as communication target from among two or more devices by outputting an "address" to the serial bus.

After the communication target device has been determined, commands and data are transmitted/received and serial communication is realized between the master and slave devices.

Figures 15-27 to 15-30 show data communication timing charts.

Shift operation of the shift register is carried out at the falling edge of serial clock ($\overline{\text{SCK0}}$). Transmit data is latched into the SO0 latch and is output with MSB set as the first bit from the SB0/P25 or SB1/P26 pin. Receive data input to the SB0 (or SB1) pin at the rising edge of $\overline{\text{SCK0}}$ is latched into the shift register.

Figure 15-27. Address Transmission from Master Device to Slave Device (WUP = 1)

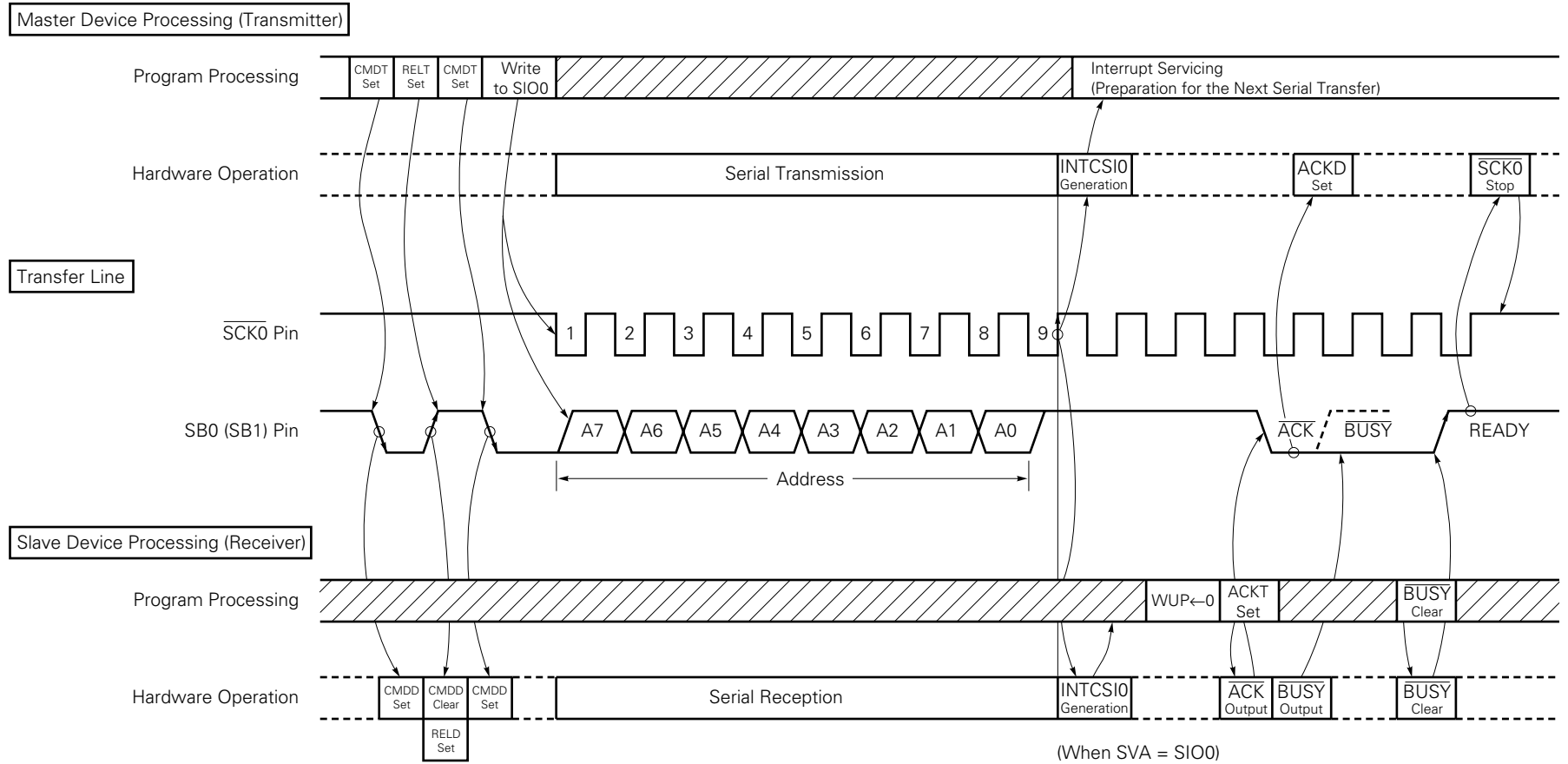


Figure 15-28. Command Transmission from Master Device to Slave Device

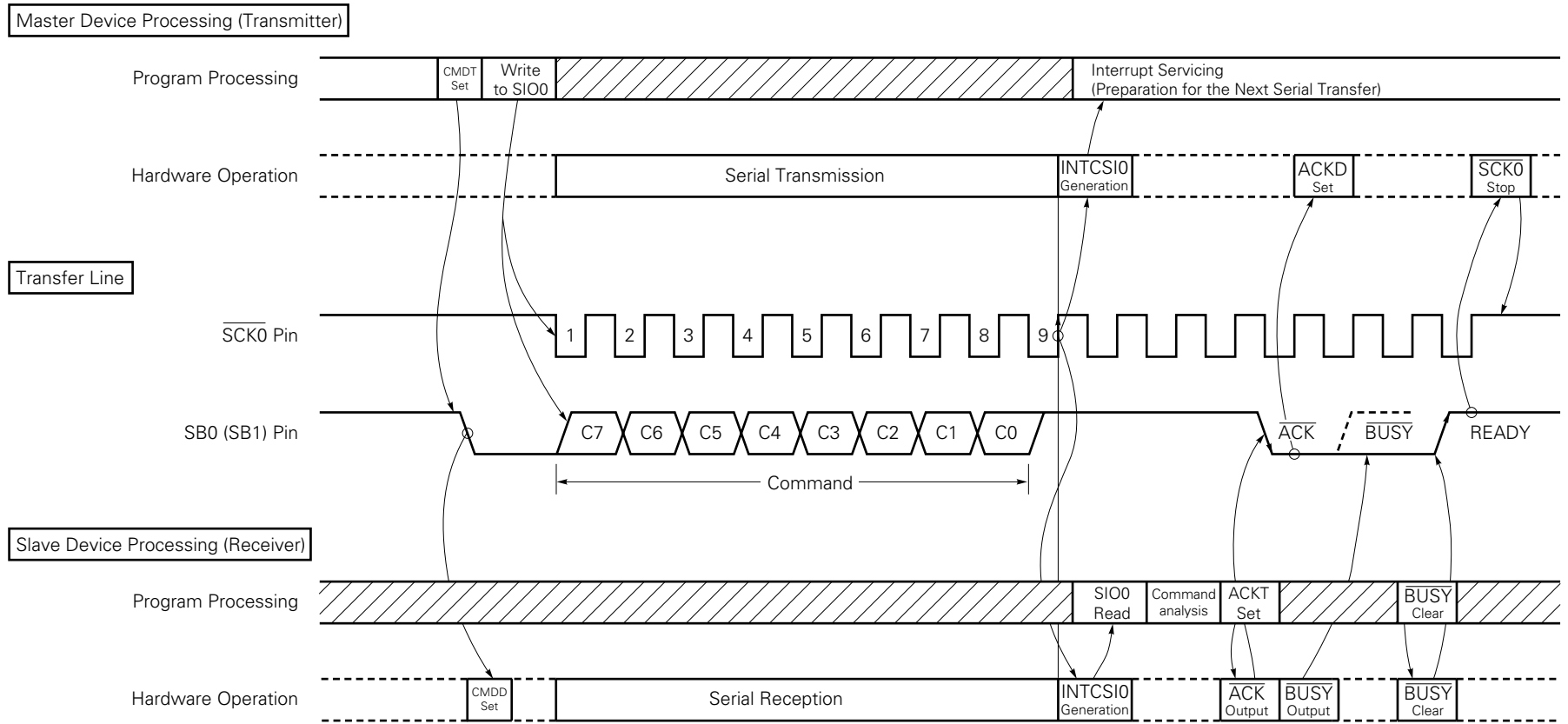


Figure 15-29. Data Transmission from Master Device to Slave Device

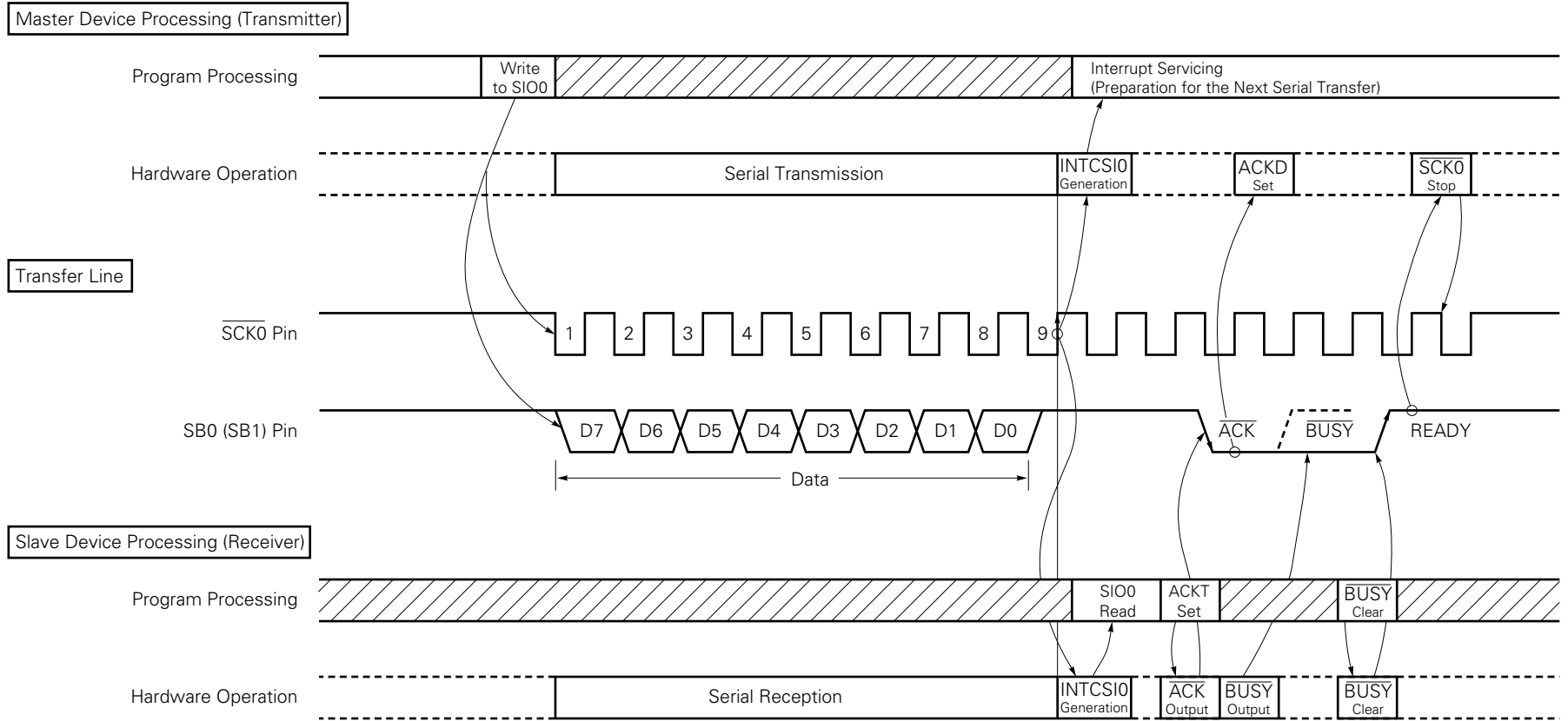
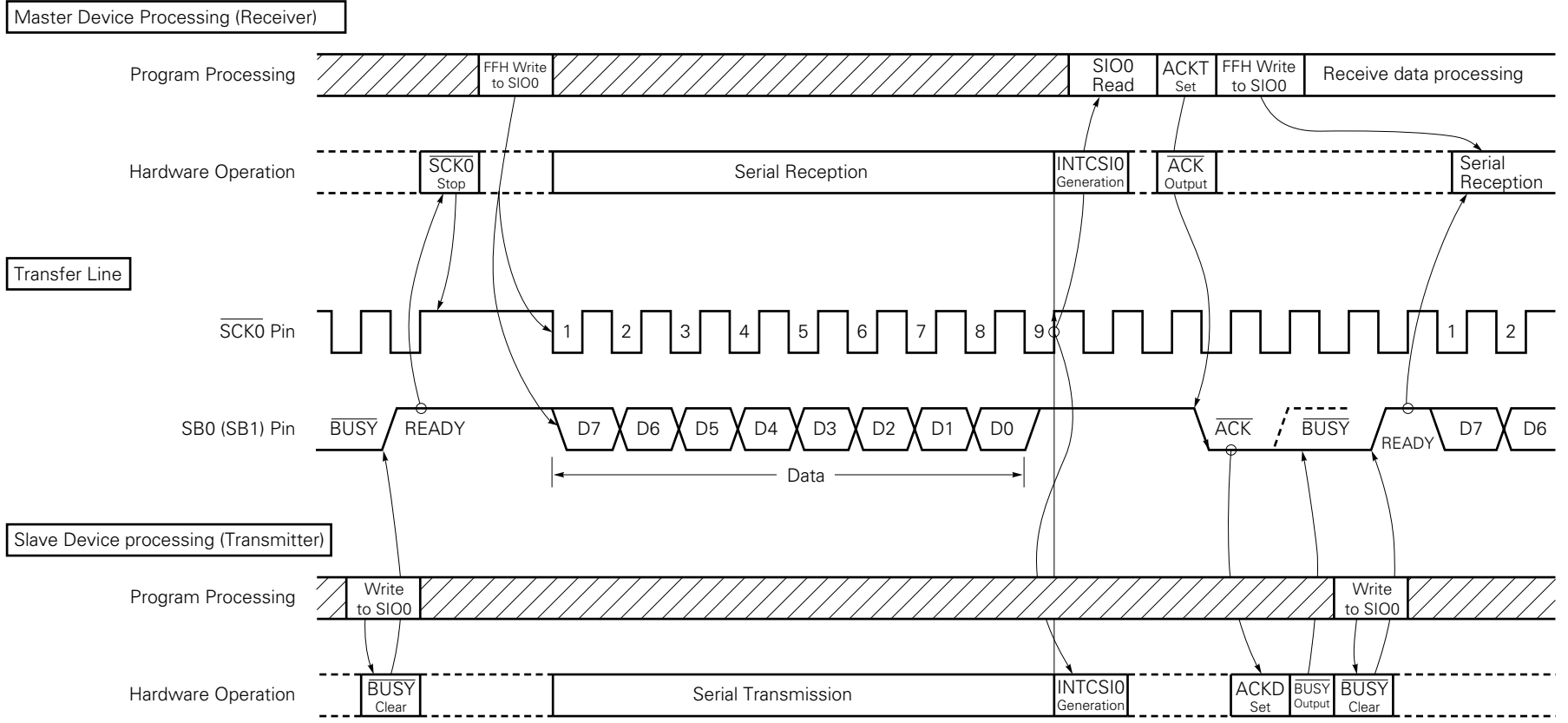


Figure 15-30. Data Transmission from Slave Device to Master Device



(9) Transfer start

Serial transfer is started by setting transfer data to the serial I/O shift register 0 (SIO0) when the following two conditions are satisfied.

- Serial interface channel 0 operation control bit (CSIE0) = 1
- Internal serial clock is stopped or $\overline{\text{SCK0}}$ is at high level after 8-bit serial transfer.

Cautions 1. If CSIE0 is set to "1" after data write to SIO0, transfer does not start.

2. Because the N-ch transistor must be turned off for data reception, write FFH to SIO0 in advance.

However, when the make-up function specify bit (WUP) = 1, the N-ch transistor is always turned off. Thus, it is not necessary to write FFH to SIO0.

3. If data is written to SIO0 when the slave is busy, the data is not lost.

When the busy state is cleared and SB0 (or SB1) input is set to the high level (READY) state, transfer starts.

Upon termination of 8-bit transfer, serial transfer automatically stops and the interrupt request flag (CSIF0) is set.

(10) SBI mode precautions

- (a) Slave selection/non-selection is detected by match detection of the slave address received after bus release (RELD = 1).

For this match detection, match interrupt (INTCSI0) of the address to be generated with WUP = 1 is normally used. Thus, execute selection/non-selection detection by slave address when WUP = 1.

- (b) When detecting selection/non-selection without the use of interrupt with WUP = 0, do so by means of transmission/reception of the command preset by program instead of using the address match detection method.

- (c) If WUP is set to 1 during $\overline{\text{BUSY}}$ signal output, $\overline{\text{BUSY}}$ is not cleared. In SBI, the $\overline{\text{BUSY}}$ signal continues to be output after $\overline{\text{BUSY}}$ clear instruction generation to the falling edge of the next serial clock ($\overline{\text{SCK0}}$). Before setting WUP to 1, be sure to clear $\overline{\text{BUSY}}$ and then check that the SB0 (SB1) has become high-level.

- (d) For pins which are to be used for data input/output, be sure to carry out the following settings before serial transfer of the 1st byte after $\overline{\text{RESET}}$ input.

<1> Set the P25 and P26 output latches to 1.

<2> Set bit 0 (RELT) of the serial bus interface control register to 1.

<3> Reset the P25 and P26 output latches from 1 to 0.

- (e) When device is in the master mode, follow the procedure below to judge whether slave device is in the busy state or not.

<1> Detect acknowledge signal ($\overline{\text{ACK}}$) or interrupt request signal generation.

<2> Set the port mode register PM25 (or PM26) of the SB0/P25 (or SB1/P26) pin into the input mode.

<3> Read out the pin state (when the pin level is high, the READY state is set).

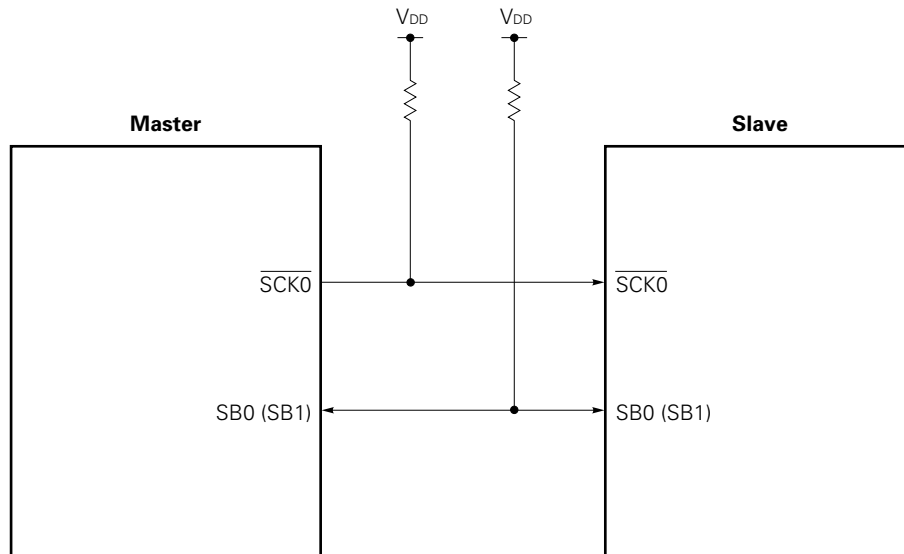
After the detection of the READY state, set the port mode register to 0 and return to the output mode.

15.4.4 2-wire serial I/O mode operation

The 2-wire serial I/O mode can cope with any communication format by program.

Communication is basically carried out with two lines of serial clock ($\overline{\text{SCK0}}$) and serial data input/output (SB0 or SB1).

Figure 15-31. Serial Bus Configuration Example Using 2-Wire Serial I/O Mode



(1) Register setting

The 2-wire serial I/O mode is set with the serial operating mode register 0 (CSIM0), the serial bus interface control register (SBIC), and the interrupt timing specify register (SINT).

*** (a) Serial operating mode register 0 (CSIM0)**

CSIM0 is set with a 1-bit or 8-bit memory manipulation instruction.

$\overline{\text{RESET}}$ input sets CSIM0 to 00H.

The shaded area is used in the 2-wire serial I/O mode.

Symbol	⑦	⑥	⑤	4	3	2	1	0	Address	After Reset	R/W
CSIM0	CSIE0	COI	WUP	CSIM04	CSIM03	CSIM02	CSIM01	CSIM00	FF60H	00H	R/W ^{Note 1}

R/W	CSIM01	CSIM00	Serial Interface Channel 0 Clock Selection
	0	×	Input Clock to $\overline{\text{SCK0}}$ pin from off-chip
	1	0	8-bit timer register 2 (TM2) output
	1	1	Clock specified with bits 0 to 3 of timer clock select register 3 (TCL3)

R/W	CSIM04	CSIM03	CSIM02	PM25	P25	PM26	P26	PM27	P27	Operation Mode	Start Bit	SIO/SB0/P25 Pin Function	SO0/SB1/P26 Pin Function	$\overline{\text{SCK0}}$ /P27 Pin Function
	0	×	3-wire Serial I/O mode (See Section 15.4.2, "3-wire serial I/O mode operation")											
	1	0	SBI mode (See section 15.4.3, "SBI mode operation")											
	1	1	0	^{Note 2} ×	^{Note 2} ×	0	0	0	1	2-wire serial I/O mode	MSB	P25 (CMOS input/output)	SB1 (N-ch open-drain input/output)	$\overline{\text{SCK0}}$ (N-ch open-drain input/output)
			1	0	0	^{Note 2} ×	^{Note 2} ×	0	1			SB0 (N-ch open-drain input/output)	P26 (CMOS input/output)	

R/W	WUP	Wake-up Function Control ^{Note 3}
	0	Interrupt request signal generation with each serial transfer in any mode
	1	Interrupt request signal generation when the address received after bus release (when CMDD=RELD=1) matches the slave address register data in SBI mode

R	COI	Slave Address Comparison Result Flag ^{Note 4}
	0	Slave address register not equal to serial I/O shift register 0 data
	1	Slave address register equal to serial I/O shift register 0 data

R/W	CSIE0	Serial Interface Channel 0 Operation Control
	0	Operation stopped
	1	Operation enabled

- Notes**
1. Bit 6 (COI) is a read-only bit.
 2. Can be used freely as port function.
 3. Be sure to set WUP to 0 when the 2-wire serial I/O mode.
 4. When CSIE0=0, COI becomes 0.

Remark × : don't care

(b) Serial bus interface control register (SBIC)

SBIC is set with a 1-bit or 8-bit memory manipulation instruction.

$\overline{\text{RESET}}$ input sets SBIC to 00H.

The shaded area is used in the 2-wire serial I/O mode.

Symbol	⑦	⑥	⑤	④	③	②	①	①	Address	After Reset	R/W
SBIC	BSYE	ACKD	ACKE	ACKT	CMDD	RELD	CMDT	RELT	FF61H	00H	R/W

R/W	RELT	When RELT = 1, SO latch is set to 1. After SO latch setting, automatically cleared to 0. Also cleared to 0 when CSIE0 = 0.
-----	------	---

R/W	CMDT	When CMDT = 1, SO latch is cleared to 0. After SO latch clearance, automatically cleared to 0. Also cleared to 0 when CSIE0 = 0.
-----	------	---

www.DataSheet4U.com

*

(c) Interrupt timing specify register (SINT)

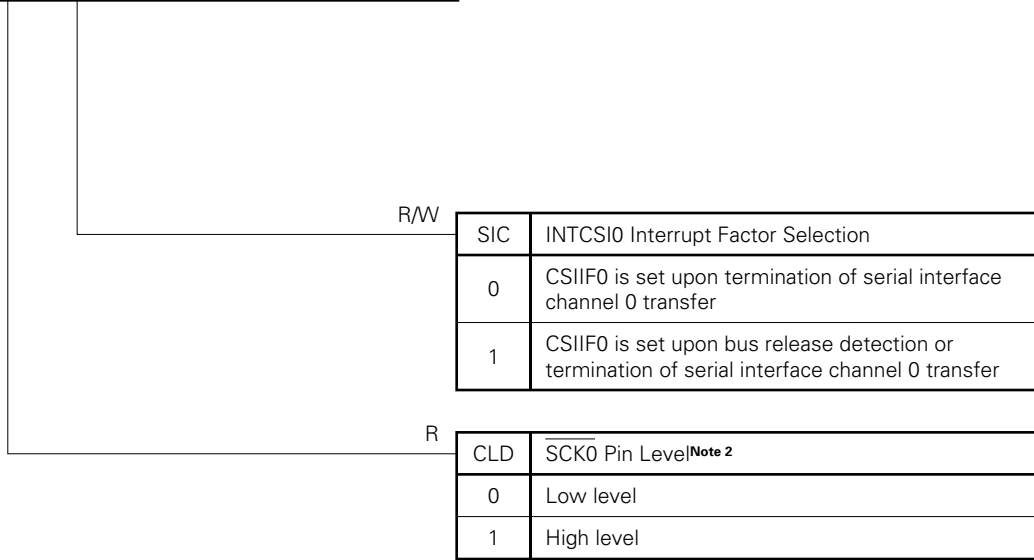
SINT is set with a 1-bit or 8-bit memory manipulation instruction.

$\overline{\text{RESET}}$ input sets SINT to 00H.

The shaded area is used in the 2-wire serial I/O mode.

Symbol	7	⑥	⑤	④	3	2	1	0	Address	After Reset	R/W
SINT	0	CLD	SIC	SVAM	0	0	0	0	FF63H	00H	R/W ^{Note 1}

www.DataSheet4U.com



- Notes**
1. Bit 6 (CLD) is a read-only bit.
 2. When CSIE0 = 0, CLD becomes 0.

Caution Be sure to set bit 0 to bit 3 to 0.

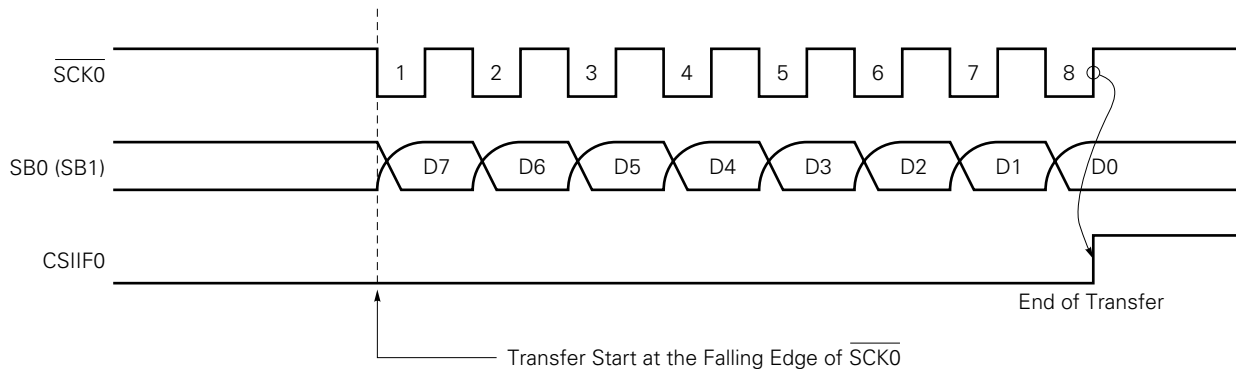
(2) Communication operation

The 2-wire serial I/O mode is used for data transmission/reception in 8-bit units. Data transmission/reception is carried out bit-wise in synchronization with the serial clock.

Shift operation of the serial I/O shift register 0 (SIO0) is carried out in synchronization with the falling edge of the serial clock ($\overline{\text{SCK0}}$). The transmit data is held in the SO0 latch and is output from the SB0/P25 (or SB1/P26) pin on an MSB-first basis. The receive data input from the SB0 (or SB1) pin is latched into the shift register at the rising edge of $\overline{\text{SCK0}}$.

Upon termination of 8-bit transfer, the shift register operation stops automatically and the interrupt request flag (CSIF0) is set.

Figure 15-32. 2-Wire Serial I/O Mode Timings



The SB0 (or SB1) pin specified for the serial data bus is an N-ch open-drain input/output and thus it must be externally connected to a pull-up resistor. Because it is necessary to turn off the N-ch transistor for data reception, write FFH to SIO0 in advance.

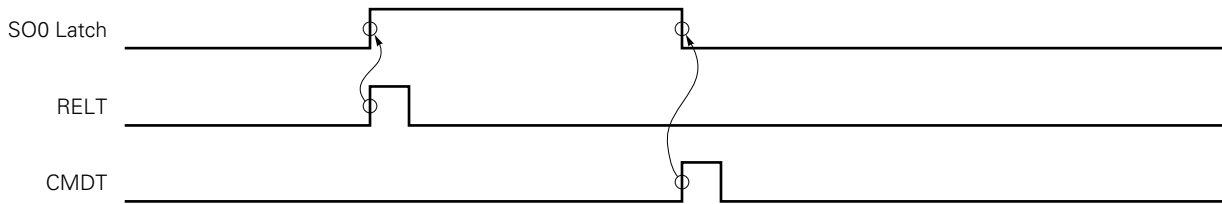
The SB0 (or SB1) pin generates the SO0 latch status and thus the SB0 (or SB1) pin output status can be manipulated by setting the RELT and CMDT bits. However, do not carry out this manipulation during serial transfer.

Control the $\overline{\text{SCK0}}$ pin output level in the output mode (internal system clock mode) by manipulating the P27 output latch (refer to **15.4.5 $\overline{\text{SCK0}}$ /P27 pin output manipulation**).

(3) Other signals

Figure 15-33 shows RELT and CMDT operations.

Figure 15-33. RELT and CMDT Operations



www.DataSheet4U.com **(4) Transfer start**

Serial transfer is started by setting transfer data to the serial I/O shift register 0 (SIO0) when the following two conditions are satisfied.

- Serial interface channel 0 operation control bit (CSIE0) = 1
- Internal serial clock is stopped or $\overline{\text{SCK0}}$ is at high level after 8-bit serial transfer.

Cautions 1. If CSIE0 is set to "1" after data write to SIO0, transfer does not start.

2. Because the N-ch transistor must be turned off for data reception, write FFH to SIO0 in advance.

Upon termination of 8-bit transfer, serial transfer automatically stops and the interrupt request flag (CSIF0) is set.

(5) Error detection

In the 2-wire serial I/O mode, the serial bus SB0 (SB1) status being transmitted is fetched into the destination device, that is, SIO0. Thus, transmit error can be detected in the following way.

(a) Method of comparing SIO0 data before transmission to that after transmission

In this case, if two data differ from each other, a transmit error is judged to have occurred.

(b) Method of using the slave address register (SVA)

Transmit data is set to both SIO0 and SVA and is transmitted. After termination of transmission, COI bit (match signal coming from the address comparator) of the serial operating mode register 0 (CSIM0) is tested. If "1", normal transmission is judged to have been carried out. If "0", a transmit error is judged to have occurred.

15.4.5 $\overline{\text{SCK0/P27}}$ pin output manipulation

Because the $\overline{\text{SCK0/P27}}$ pin incorporates an output latch, static output is also possible by software in addition to normal serial clock output.

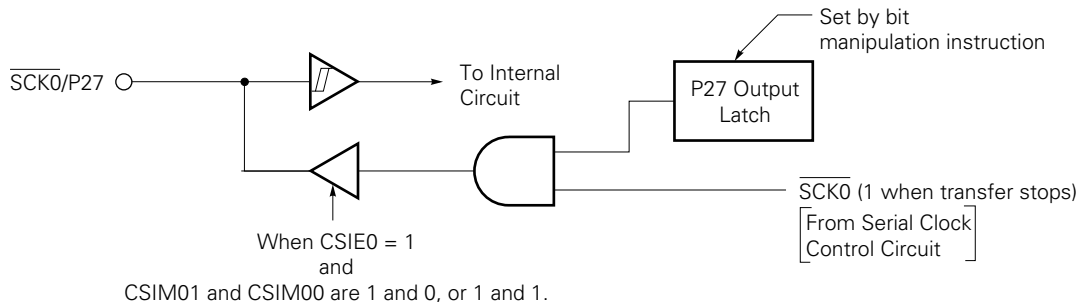
P27 output latch manipulation enables any number of $\overline{\text{SCK0}}$ to be set by software. (SI0/SB0 and SO0/SB1 pin to be controlled with the RELT and CMDT bits of SBIC.)

$\overline{\text{SCK0/P27}}$ pin output manipulating procedure is described below.

- ① Set the serial operating mode register 0 (CSIM0) ($\overline{\text{SCK0}}$ pin is set in the output mode and serial operation is enabled). While serial transfer is suspended, $\overline{\text{SCK0}}$ is set to 1.
- ② Manipulate the content of the P27 output latch by executing the bit manipulation instruction.

Figure 15-34. $\overline{\text{SCK0/P27}}$ Pin Configuration

*



[MEMO]

www.DataSheet4U.com

The μ PD78064Y subseries incorporates two channels of serial interfaces. Differences between channels 0 and 2 are as follows (Refer to **CHAPTER 17 SERIAL INTERFACE CHANNEL 2** for details of the serial interface channel 2).

Table 16-1. Differences between Channels 0 and 2

Serial Transfer Mode		Channel 0	Channel 2
3-wire serial I/O	Clock selection	$f_{xx}/2$, $f_{xx}/2^2$, $f_{xx}/2^3$, $f_{xx}/2^4$, $f_{xx}/2^5$, $f_{xx}/2^6$, $f_{xx}/2^7$, $f_{xx}/2^8$, external clock, TO2 output	External clock, baud rate generator output
	Transfer method	MSB/LSB switchable as the start bit	MSB/LSB switchable as the start bit
	Transfer end flag	Serial transfer end interrupt request flag (CSIF0)	Serial transfer end interrupt request flag (SRIF)
I ² C bus (Inter IC Bus)	Use possible	None	
2-wire serial I/O			
UART (Asynchronous serial interface)	None	Use possible	

16.1 Serial Interface Channel 0 Functions

Serial interface channel 0 employs the following four modes.

- Operation stop mode
- 3-wire serial I/O mode
- 2-wire serial I/O mode
- I²C (Inter IC) bus mode

(1) Operation stop mode

This mode is used when serial transfer is not carried out. Power consumption can be reduced.

(2) 3-wire serial I/O mode (MSB-/LSB-first selectable)

This mode is used for 8-bit data transfer using three lines, one each for serial clock ($\overline{\text{SCK0}}$), serial output (SO0) and serial input (SI0). This mode enables simultaneous transmission/reception and therefore reduces the data transfer processing time.

The start bit of transferred 8-bit data is switchable between MSB and LSB, so that devices can be connected regardless of their start bit recognition.

This mode should be used when connecting with peripheral I/O devices or display controllers which incorporate a conventional synchronous clocked serial interface as is the case with the 75X, 78K, and 17K series.

(3) 2-wire serial I/O mode (MSB-first)

This mode is used for 8-bit data transfer using two lines of serial clock ($\overline{\text{SCK0}}$) and serial data bus (SB0 or SB1).

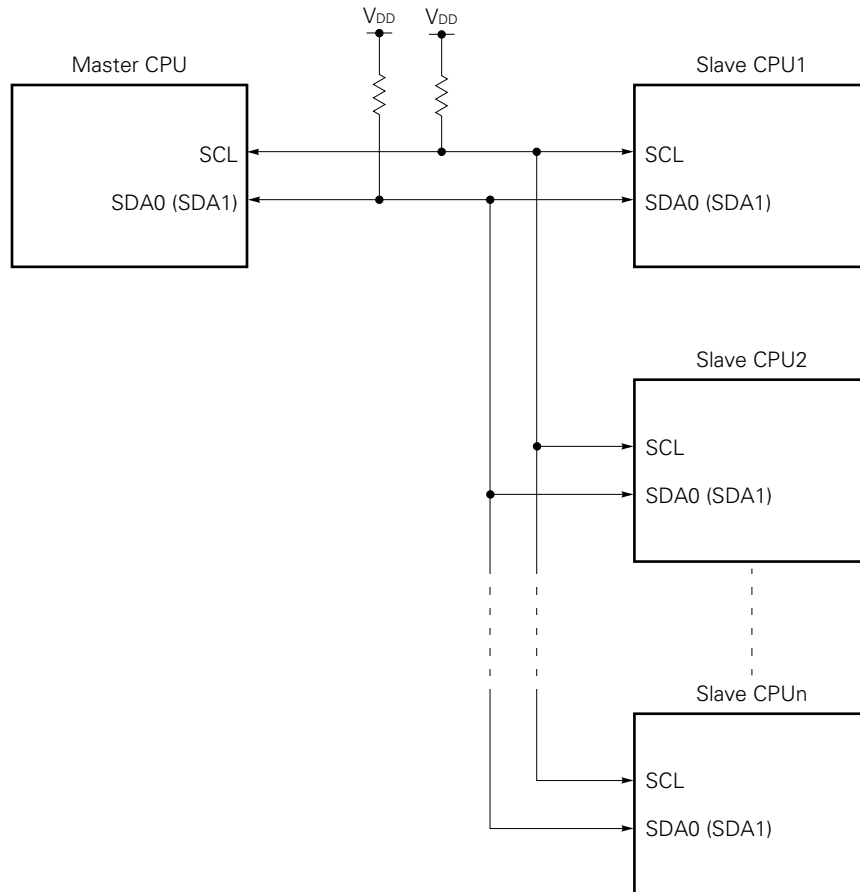
This mode enables to cope with any one of the possible data transfer formats by controlling the $\overline{\text{SCK0}}$ level and the SB0 or SB1 output level. Thus, the handshake line previously necessary for connection of two or more devices can be removed, resulting in the increased number of available input/output ports.

(4) I²C (Inter IC) bus mode (MSB-first)

This mode is used for 8-bit data transfer with two or more devices using two lines of serial clock (SCL) and serial data bus (SDA0 or SDA1).

This mode is in compliance with the I²C bus format. In this mode, the transmitter outputs three kinds of data onto the serial data bus: "start condition", "data", and "stop condition", to be actually sent or received. The receiver automatically distinguishes the received data into "start condition", "data", or "stop condition", by hardware.

Figure 16-1. Serial Bus Configuration Example Using I²C Bus



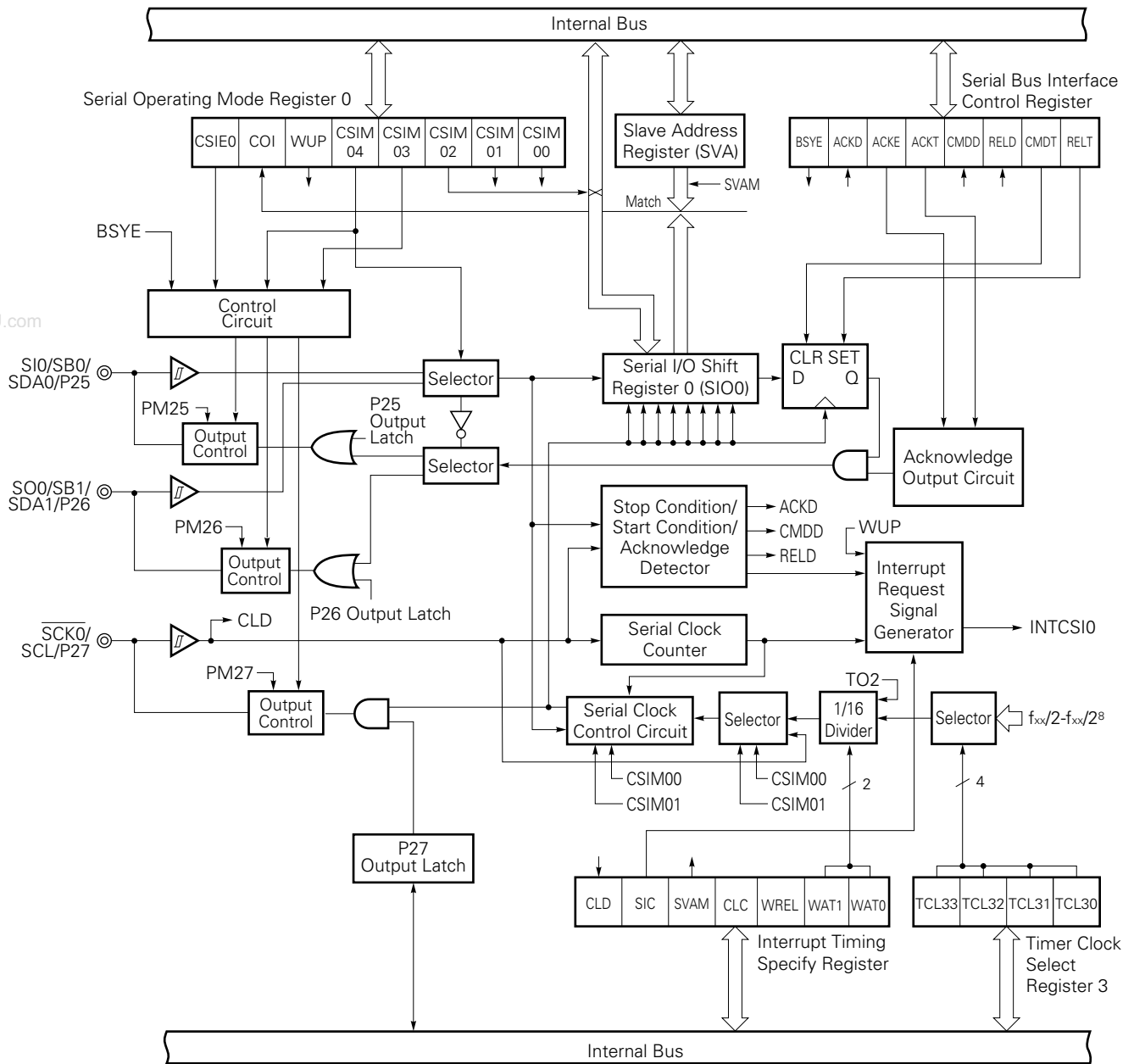
16.2 Serial Interface Channel 0 Configuration

Serial interface channel 0 consists of the following hardware.

Table 16-2. Serial Interface Channel 0 Configuration

Item	Configuration
Register	Serial I/O shift register 0 (SIO0) Slave address register (SVA)
Control register	Timer clock select register 3 (TCL3) Serial operating mode register 0 (CSIM0) Serial bus interface control register (SBIC) Interrupt timing specify register (SINT) Port mode register 2 (PM2)

Figure 16-2. Serial Interface Channel 0 Block Diagram



Remark Output Control performs selection between CMOS output and N-ch open drain output.

(1) Serial I/O shift register 0 (SIO0)

This is an 8-bit register to carry out parallel-serial conversion and to carry out serial transmission/reception (shift operation) in synchronization with the serial clock.

SIO0 is set with an 8-bit memory manipulation instruction.

When bit 7 (CSIE0) of serial operating mode register 0 (CSIM0) is 1, writing data to SIO0 starts serial operation. In transmission, data written to SIO0 is output to the serial output (SO0) or serial data bus (SB0/SB1). In reception, data is read from the serial input (SI0) or SB0/SB1 to SIO0.

Note that, if a bus is driven in the I²C bus mode or 2-wire serial I/O mode, the bus pin must serve for both input and output. Therefore, the transmission N-ch transistor of the device which will start reception of data must be turned off beforehand. Consequently, write FFH to SIO0 in advance.

In the I²C bus mode, set SIO0 to FFH with bit 7 (BSYE) of the serial bus interface control register (SBIC) set to 0.

$\overline{\text{RESET}}$ input makes SIO0 undefined.

(2) Slave address register (SVA)

This is an 8-bit register to set the slave address value for connection of a slave device to the serial bus.

SVA is set with an 8-bit memory manipulation instruction.

The master device outputs a slave address for selection of a particular slave device to the connected slave device. These two data (the slave address output from the master device and the SVA value) are compared with an address comparator. If they match, the slave device has been selected. In that case, bit 6 (COI) of serial operating mode register 0 (CSIM0) becomes 1.

Address comparison can also be executed on the data of LSB-masked high-order 7 bits with bit 4 (SVAM) of the interrupt timing specify register (SINT).

If no matching is detected in address reception, bit 2 (RELD) of the serial bus interface control register (SBIC) is cleared to 0. When bit 5 (WUP) of CSIM0 is 1, the interrupt request signal (INTCSI0) is generated only if the matching is detected. This interrupt request enables to recognize the generation of the communication request from the master device.

Further, when SVA transmits data as master or slave device in the the I²C bus mode or 2-wire serial I/O mode, errors are detected if any.

$\overline{\text{RESET}}$ input makes SVA undefined.

(3) SO0 latch

This latch holds SI0/SB0/SDA0/P25 and SO0/SB1/SDA1/P26 pin levels. It can be directly controlled by software.

(4) Serial clock counter

This counter counts the serial clocks to be output and input during transmission/reception and to check whether 8-bit data has been transmitted/received.

(5) Serial clock control circuit

This circuit controls serial clock supply to the serial I/O shift register 0 (SIO0). When the internal system clock is used, the circuit also controls clock output to the $\overline{\text{SCK0}}$ /SCL/P27 pin.

(6) Interrupt request signal generator

This circuit controls interrupt request signal generation. It generates interrupt request signals according to the settings of interrupt timing specification register (SINT) bits 0 and 1 (WAT0, WAT1) and serial operation mode register 0 (CSIM0) bit 5 (WUP), as shown in Table 16-3.

(7) Acknowledge output circuit and stop condition/start condition/acknowledge detector

These two circuits output and detect various control signals in the I²C mode.

These do not operate in the 3-wire serial I/O mode and 2-wire serial I/O mode.

Table 16-3. Serial Interface Channel 0 Interrupt Request Signal Generation

Serial Transfer mode	BSYE	WUP	WAT1	WAT0	ACKE	Description
3-wire or 2-wire serial I/O mode	0	0	0	0	0	An interrupt request signal is generated each time 8 serial clocks are counted.
	Other than above					Setting prohibited
I ² C bus mode (transmit)	0	0	1	0	0	An interrupt request signal is generated each time 8 serial clocks are counted (8-clock wait). Normally, during transmission the settings WAT21, WAT0=1, 0, are not used. They are used only when wanting to coordinate receive time and processing systematically using software. ACK information is generated by the receiving side, thus ACKE should be set to 0 (disable).
			1	1	0	An interrupt request signal is generated each time 9 serial clocks are counted (9-clock wait). ACK information is generated by the receiving side, thus ACKE should be set to 0 (disable).
	Other than above					Setting prohibited
I ² C bus mode (receive)	1	0	1	0	0	An interrupt request signal is generated each time 8 serial clocks are counted (8-clock wait). ACK information is output by manipulating ACKT by software after an interrupt is generated.
			1	1	0/1	An interrupt request signal is generated each time 9 serial clocks are counted (9-clock wait). To automatically generate ACK information, preset ACKE to 1 before transfer start. However, in the case of the master, set ACKE to 0 (disable) before receiving the last data.
	1	1	1	1	1	After address is received, if the values of the serial I/O shift register 0 (SI00) and the slave address register (SVA) match, an interrupt request signal is generated. To automatically generate ACK information, preset ACKE to 1 (enable) before transfer start.
	Other than above					Setting prohibited

Remark BSYE: Bit 7 of serial bus interface control register (SBIC)
 ACKE: Bit 5 of serial bus interface control register (SBIC)

16.3 Serial Interface Channel 0 Control Registers

The following four types of registers are used to control serial interface channel 0.

- Timer clock select register 3 (TCL3)
- Serial operating mode register 0 (CSIM0)
- Serial bus interface control register (SBIC)
- Interrupt timing specify register (SINT)

(1) Timer clock select register 3 (TCL3)

This register sets the serial clock of serial interface channel 0.

TCL3 is set with an 8-bit memory manipulation instruction.

www.DataSheet4U.com $\overline{\text{RESET}}$ input sets TCL3 to 88H.

Figure 16-3. Timer Clock Select Register 3 Format

Symbol	7	6	5	4	3	2	1	0	Address	After Reset	R/W
TCL3	1	0	0	0	TCL33	TCL32	TCL31	TCL30	FF43H	88H	R/W

TCL33	TCL32	TCL31	TCL30	Serial Interface Channel 0 Serial Clock Selection					
				Serial Clock in I ² C Bus Mode			Serial Clock in 2-Wire or 3-Wire Serial I/O Mode		
					MCS = 1	MCS = 0		MCS = 1	MCS = 0
0	1	1	0	$f_{xx}/2^5$	Setting prohibited	$f_x/2^6$ (78.1 kHz)	$f_{xx}/2$	Setting prohibited	$f_x/2^2$ (1.25 MHz)
0	1	1	1	$f_{xx}/2^6$	$f_x/2^6$ (78.1 kHz)	$f_x/2^7$ (39.1 kHz)	$f_{xx}/2^2$	$f_x/2^2$ (1.25 MHz)	$f_x/2^3$ (625 kHz)
1	0	0	0	$f_{xx}/2^7$	$f_x/2^7$ (39.1 kHz)	$f_x/2^8$ (19.5 kHz)	$f_{xx}/2^3$	$f_x/2^3$ (625 kHz)	$f_x/2^4$ (313 kHz)
1	0	0	1	$f_{xx}/2^8$	$f_x/2^8$ (19.5 kHz)	$f_x/2^9$ (9.77 kHz)	$f_{xx}/2^4$	$f_x/2^4$ (313 kHz)	$f_x/2^5$ (156 kHz)
1	0	1	0	$f_{xx}/2^9$	$f_x/2^9$ (9.77 kHz)	$f_x/2^{10}$ (4.88 kHz)	$f_{xx}/2^5$	$f_x/2^5$ (156 kHz)	$f_x/2^6$ (78.1 kHz)
1	0	1	1	$f_{xx}/2^{10}$	$f_x/2^{10}$ (4.88 kHz)	$f_x/2^{11}$ (2.44 kHz)	$f_{xx}/2^6$	$f_x/2^6$ (78.1 kHz)	$f_x/2^7$ (39.1 kHz)
1	1	0	0	$f_{xx}/2^{11}$	$f_x/2^{11}$ (2.44 kHz)	$f_x/2^{12}$ (1.22 kHz)	$f_{xx}/2^7$	$f_x/2^7$ (39.1 kHz)	$f_x/2^8$ (19.5 kHz)
1	1	0	1	$f_{xx}/2^{12}$	$f_x/2^{12}$ (1.22 kHz)	$f_x/2^{13}$ (0.61 kHz)	$f_{xx}/2^8$	$f_x/2^8$ (19.5 kHz)	$f_x/2^9$ (9.8 kHz)
Other than above				Setting prohibited					

- Cautions**
1. Set bit 4 to bit 6 to 0, and bit 7 to 1.
 2. When rewriting TCL3 to other data, stop the serial transfer operation beforehand.

- Remarks**
1. f_{xx} : Main system clock frequency (f_x or $f_x/2$)
 2. f_x : Main system clock oscillation frequency
 3. MCS : Oscillation mode selection register bit 0
 4. Figures in parentheses apply to operation with $f_x = 5.0$ MHz.

(2) Serial operating mode register 0 (CSIM0)

This register sets serial interface channel 0 serial clock, operating mode, operation enable/stop wake-up function and displays the address comparator match signal.

CSIM0 is set with a 1-bit or 8-bit memory manipulation instruction.

RESET input sets CSIM0 to 00H.

Figure 16-4. Serial Operating Mode Register 0 Format

Symbol	⑦	⑥	⑤	4	3	2	1	0	Address	After Reset	R/W
CSIM0	CSIE0	COI	WUP	CSIM04	CSIM03	CSIM02	CSIM01	CSIM00	FF60H	00H	R/W ^{Note 1}

R/W	CSIM01	CSIM00	Serial Interface Channel 0 Clock Selection
	0	×	Input Clock to SCK0/SCL pin from off-chip
	1	0	8-bit timer register 2 (TM2) output ^{Note2}
	1	1	Clock specified with bits 0 to 3 of timer clock select register 3 (TCL3)

R/W	CSIM04	CSIM03	CSIM02	PM25	PM25	PM26	PM26	PM27	PM27	Operation Mode	Start Bit	SI0/SB0/SDA0/ P25 Pin Function	SO0/SB1/SDA1/ P26 Pin Function	SCK0/SCL/P27 Pin Function
	0	×	0	^{Note3} 1	^{Note3} ×	0	0	0	1	3-wire serial I/O mode	MSB LSB	SI0 ^{Note3} (Input)	SO0 (CMOS output)	SCK0 (CMOS input/output)
	1	1	0	^{Note4} ×	^{Note4} ×	0	0	0	1	2-wire serial I/O mode or I ² C Bus Mode	MSB	P25 (CMOS input/output)	SB1/SDA1 (N-ch open-drain input/output)	SCK0/SCL (N-ch open-drain input/output)
			1	0	0	^{Note4} ×	^{Note4} ×	0	1			SB0/SDA0 (N-ch open-drain input/output)	P26 (CMOS input/output)	

R/W	WUP	Wake-up Function Control
	0	Interrupt request signal generation with each serial transfer in any mode
	1	Interrupt request signal generation when the address received after detecting start condition (when CMDD = 1) matches the slave address register data in I ² C bus mode

R	COI	Slave Address Comparison Result Flag ^{Note5}
	0	Slave address register not equal to serial I/O shift register 0 data
	1	Slave address register equal to serial I/O shift register 0 data

R/W	CSIE0	Serial Interface Channel 0 Operation Control
	0	Operation stopped
	1	Operation enabled

- Notes**
1. Bit 6 (COI) is a read-only bit.
 2. I²C bus mode, the clock frequency becomes 1/16 of that output from TO2.
 3. Can be used as P25 (CMOS input/output) when used only for transmission.
 4. Can be used freely as port function.
 5. When CSIE0 = 0, COI becomes 0.

Remark × : don't care

(3) Serial bus interface control register (SBIC)

This register sets serial bus interface operation and displays statuses.

SBIC is set with a 1-bit or 8-bit memory manipulation instruction.

$\overline{\text{RESET}}$ input sets SBIC to 00H.

Figure 16-5. Serial Bus Interface Control Register Format (1/2)

Symbol	⑦	⑥	⑤	④	③	②	①	①	①	①	Address	After Reset	R/W
SBIC	BSYE	ACKD	ACKE	ACKT	CMDD	RELD	CMDT	RELT			FF61H	00H	R/W ^{Note}

R/W	RELT	Used for stop condition signal output. When RELT = 1, SO latch is set to 1. After SO latch setting, automatically cleared to 0. Also cleared to 0 when CSIE0 = 0.
-----	------	---

R/W	CMDT	Used for start condition signal output. When CMDT = 1, SO latch is cleared to (0). After SO latch clearance, automatically cleared to 0. Also cleared to 0 when CSIE0 = 0.
-----	------	--

R	RELD	Stop Condition Detection
Clear Conditions (RELD = 0)		Set Conditions (RELD = 1)
<ul style="list-style-type: none"> • When transfer start instruction is executed • If SIO0 and SVA values do not match in address reception • When CSIE0 = 0 • When $\overline{\text{RESET}}$ input is applied 		<ul style="list-style-type: none"> • When stop condition signal is detected

R	CMDD	Start Condition Detection
Clear Conditions (CMDD = 0)		Set Conditions (CMDD = 1)
<ul style="list-style-type: none"> • When transfer start instruction is executed • When stop condition signal is detected • When CSIE0 = 0 • When $\overline{\text{RESET}}$ input is applied 		<ul style="list-style-type: none"> • When start condition signal is detected

R/W	ACKT	Used to generate the $\overline{\text{ACK}}$ signal by software when 8-clock wait mode is selected. Keeps SDA0 (SDA1) low from set instruction (ACKT=1) execution to the next falling edge of SCL. Also cleared to 0 upon start of serial interface transfer or when CSIE0 = 0.
-----	------	---

Note Bits 2, 3, and 6 (RELD, CMDD and ACKD) are read-only bits.

Figure 16-5. Serial Bus Interface Control Register Format (2/2)

R/W	ACKE	Acknowledge Signal Output Control ^{Note1}	
	0	Disables acknowledge signal automatic output. (However, output with ACKT is enabled) Used for reception when 8-clock wait mode is selected or for transmission. ^{Note2}	
	1	Enables acknowledge signal automatic output. Outputs acknowledge signal in synchronization with the falling edge of the 9th SCL clock cycle (automatically output when ACKE = 1). However, not automatically cleared to 0 after acknowledge signal output. Used in reception with 9-clock wait mode selected.	
R	ACKD	Acknowledge Detection	
		Clear Conditions (ACKD = 0)	Set Conditions (ACKD = 1)
		<ul style="list-style-type: none"> • While executing the transfer start instruction • When CSIE0 = 0 • When RESET input is applied 	<ul style="list-style-type: none"> • When acknowledge signal ($\overline{\text{ACK}}$) is detected at the rising edge of SCL clock after completion of transfer
R/W	^{Note3} BSYE	Control of N-ch Open-Drain Output for Transmission in I ² C Bus Mode ^{Note4}	
	0	Output enabled (transmission)	
	1	Output disabled (reception)	

- Notes**
1. Setting should be performed before transfer.
 2. If 8-clock wait mode is selected, the acknowledge signal at reception time must be output using ACKT.
 3. The busy mode can be canceled by start of serial interface transfer or reception of address signal. However, the BSYE flag is not cleared to 0.
 4. When using the wake-up function, be sure to set BSYE to 1.

(4) Interrupt timing specify register (SINT)

This register sets the bus release interrupt and address mask functions and displays the $\overline{\text{SCK0}}$ /SCL pin level status. SINT is set with a 1-bit or 8-bit memory manipulation instruction. $\overline{\text{RESET}}$ input sets SINT to 00H.

Figure 16-6. Interrupt Timing Specify Register Format (1/2)

Symbol	7	⑥	⑤	④	③	②	1	0	Address	After Reset	R/W
SINT	0	CLD	SIC	SVAM	CLC	WREL	WAT1	WAT0	FF63H	00H	R/W ^{Note 1}

R/W	WAT1	WAT0	Wait and Interrupt Control
	0	0	Generates interrupt service request at rising edge of 8th $\overline{\text{SCK0}}$ clock cycle. (keeping clock output in high impedance)
	0	1	Setting prohibited
	1	0	Used in I ² C bus mode. (8-clock wait) Generates interrupt service request at rising edge of 8th $\overline{\text{SCK0}}$ clock cycle. (In the case of master device, makes SCL output low to enter wait state after 8 clock pulses are output. In the case of slave device, makes SCL output low to request wait state after 8 clock pulses are input.)
	1	1	Used in I ² C bus mode. (9-clock wait) Generates interrupt service request at rising edge of 9th $\overline{\text{SCK0}}$ clock cycle. (In the case of master device, makes SCL output low to enter wait state after 9 clock pulses are output. In the case of slave device, makes SCL output low to request wait state after 9 clock pulses are input.)

R/W	WREL	Wait State Cancellation Control
	0	Wait state has been cancelled.
	1	Cancels wait state. Automatically cleared to 0 when the state is cancelled. (Used to cancel wait state by means of WAT0 and WAT1.)

R/W	CLC	Clock Level Control ^{Note2}
	0	Used in I ² C bus mode. Make output level of SCL pin low unless serial transfer is being performed.
	1	Used in I ² C bus mode. Make SCL pin enter high-impedance state unless serial transfer is being performed. (except for clock line which is kept high) Used to enable master device to generate start condition and stop condition signals.

- Notes**
1. Bit 6 (CLD) is a read-only bit.
 2. When not using the I²C mode, set CLC to 0.

Figure 16-6. Interrupt Timing Specify Register Format (2/2)

R/W	SVAM	SVA Bit to be Used as Slave Address
	0	Bits 0 to 7
	1	Bits 1 to 7
R/W	SIC	INTCSI0 Interrupt Cause Selection Note1
	0	CSIIF0 is set to 1 upon termination of serial interface channel 0 transfer
	1	CSIIF0 is set to 1 upon stop condition detection or termination of serial interface channel 0 transfer
R	CLD	$\overline{\text{SCK0/SCL}}$ Pin Level Note2
	0	Low level
	1	High level

Notes 1. When using wake-up function in the I²C mode, set SIC to 1.

2. When CSIE0 = 0, CLD becomes 0.

Remark SVA : Slave address register

16.4 Serial Interface Channel 0 Operations

The following four operating modes are available to the serial interface channel 0.

- Operation stop mode
- 3-wire serial I/O mode
- 2-wire serial I/O mode
- I²C (Inter IC) bus mode

16.4.1 Operation stop mode

Serial transfer is not carried out in the operation stop mode. Thus, power consumption can be reduced. The serial I/O shift register 0 (SIO0) does not carry out shift operation either and thus it can be used as ordinary 8-bit register.

In the operation stop mode, the P25/SI0/SB0/SDA0, P26/SO0/SB1/SDA1 and P27/ $\overline{\text{SCK0}}$ /SCL pins can be used as general input/output ports.

(1) Register setting

The operation stop mode is set with the serial operating mode register 0 (CSIM0).

CSIM0 is set with a 1-bit or 8-bit memory manipulation instruction.

$\overline{\text{RESET}}$ input sets CSIM0 to 00H.

The shaded area is used in the operation stop mode.

Symbol	⑦	⑥	⑤	4	3	2	1	0	Address	After Reset	R/W
CSIM0	CSIE0	COI	WUP	CSIM04	CSIM03	CSIM02	CSIM01	CSIM00	FF60H	00H	R/W

R/W	CSIE0	Serial Interface Channel 0 Operation Control
	0	Operation stopped
	1	Operation enabled

16.4.2 3-wire serial I/O mode operation

The 3-wire serial I/O mode is valid for connection of peripheral I/O units and display controllers which incorporate a conventional synchronous clocked serial interface as is the case with the 75X, 78K, and 17K series.

Communication is carried out with three lines of serial clock ($\overline{SCK0}$), serial output (SO0), and serial input (SI0).

(1) Register setting

The 3-wire serial I/O mode is set with the serial operating mode register 0 (CSIM0) and serial bus interface control register (SBIC).

(a) Serial operating mode register 0 (CSIM0)

CSIM0 is set with a 1-bit or 8-bit memory manipulation instruction.

\overline{RESET} input sets CSIM0 to 00H.

The shaded area is used in the 3-wire serial I/O mode.

Symbol	⑦	⑥	⑤	4	3	2	1	0	Address	After Reset	R/W
CSIM0	CSIE0	COI	WUP	CSIM04	CSIM03	CSIM02	CSIM01	CSIM00	FF60H	00H	R/W ^{Note 1}

R/W	CSIM01	CSIM00	Serial Interface Channel 0 Clock Selection								
	0	×	Input Clock to $\overline{SCK0}$ pin from off-chip								
	1	0	8-bit timer register 2 (TM2) output								
	1	1	Clock specified with bits 0 to 3 of timer clock select register 3 (TCL3)								

R/W	CSIM04	CSIM03	CSIM02	PM25	P25	PM26	P26	PM27	P27	Operation Mode	Start Bit	SIO/SB0/SDA0 /P25 Pin Function	SO0/SB1/SDA1 /P26 Pin Function	$\overline{SCK0}$ /SCL/P27 Pin Function
	0	×	0	^{Note 2} 1	^{Note 2} ×	0	0	0	1	3-wire serial I/O mode	MSB	SIO ^{Note 2} (Input)	SO0 (CMOS output)	$\overline{SCK0}$ (CMOS input/output)
			1						LSB					
	1	1	2-wire serial I/O mode (See section 16.4.3, "2-wire serial I/O mode operation".) or I ² C bus mode (See section 16.4.4, "I ² C bus mode operation".)											

R/W	WUP	Wake-up Function Control ^{Note 3}									
	0	Interrupt request signal generation with each serial transfer in any mode									
	1	Interrupt request signal generation when the address received after detecting start condition (when CMDD=1) matches the slave address register data in I ² C bus mode									

R/W	CSIE0	Serial Interface Channel 0 Operation Control									
	0	Operation stopped									
	1	Operation enabled									

- Notes**
1. Bit 6 (COI) is a read-only bit.
 2. Can be used as P25 (CMOS input/output) when used only for transmission.
 3. Be sure to set WUP to 0 when the 3-wire serial I/O mode is selected.

Remark × : don't care

(b) Serial bus interface control register (SBIC)

SBIC is set with a 1-bit or 8-bit memory manipulation instruction.

$\overline{\text{RESET}}$ input sets SBIC to 00H.

The shaded area is used in the 3-wire serial I/O mode.

Symbol	⑦	⑥	⑤	④	③	②	①	①	①	Address	After Reset	R/W
SBIC	BSYE	ACKD	ACKE	ACKT	CMDD	RELD	CMDT	RELT		FF61H	00H	R/W

R/W	RELT	When RELT = 1, SO latch is set to 1. After SO latch setting, automatically cleared to 0. Also cleared to 0 when CSIE0 = 0.
-----	------	---

R/W	CMDT	When CMDT = 1, SO latch is cleared to 0. After SO latch clearance, automatically cleared to 0. Also cleared to 0 when CSIE0 = 0.
-----	------	---

www.DataSheet4U.com

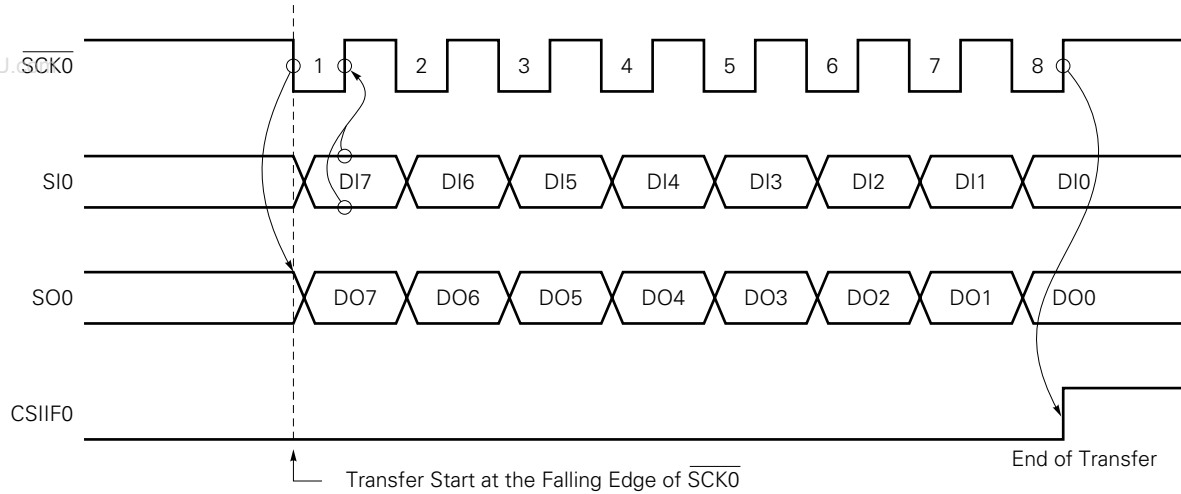
(2) Communication operation

The 3-wire serial I/O mode is used for data transmission/reception in 8-bit units. Bit-wise data transmission/reception is carried out in synchronization with the serial clock.

Shift operation of the serial I/O shift register 0 (SIO0) is carried out at the falling edge of the serial clock ($\overline{\text{SCK0}}$). The transmitted data is held in the SO0 latch and is output from the SO0 pin. The received data input to the SIO pin is latched in SIO0 at the rising edge of $\overline{\text{SCK0}}$.

Upon termination of 8-bit transfer, SIO0 operation stops automatically and the interrupt request flag (CSIF0) is set.

Figure 16-7. 3-Wire Serial I/O Mode Timings



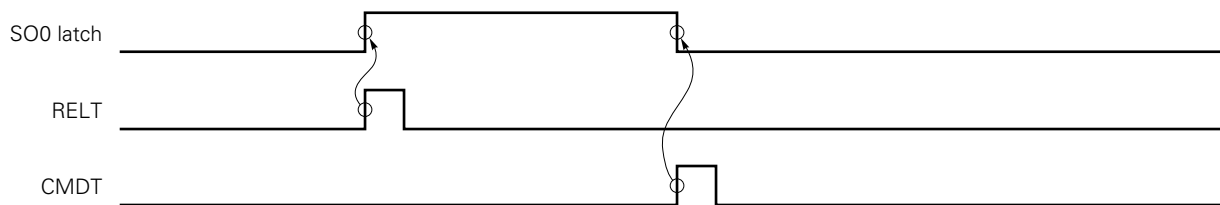
The SO0 pin is a CMOS output pin and outputs current SO0 latch statuses. Thus, the SO0 pin output status can be manipulated by setting the RELT and CMDT bits. However, do not carry out this manipulation during serial transfer.

Control the $\overline{\text{SCK0}}$ pin output level in the output mode (internal system clock mode) by manipulating the P27 output latch (refer to **16.4.6 $\overline{\text{SCK0}}$ /SCL/P27 pin output manipulation**).

(3) Other signals

Figure 16-8 shows RELT and CMDT operations.

Figure 16-8. RELT and CMDT Operations



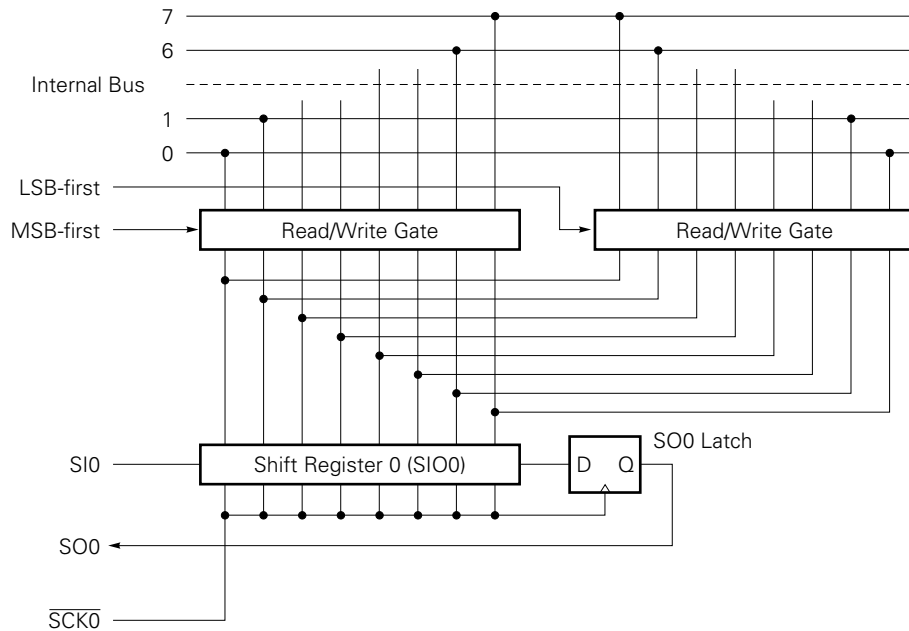
(4) MSB/LSB switching as the start bit

The 3-wire serial I/O mode enables to select transfer to start from MSB or LSB.

Figure 16-9 shows the configuration of the serial I/O shift register 0 (SIO0) and internal bus. As shown in the figure, MSB/LSB can be read/written in reverse form.

MSB/LSB switching as the start bit can be specified with bit 2 (CSIM02) of the serial operating mode register 0 (CSIM0).

Figure 16-9. Circuit of Switching in Transfer Bit Order



Start bit switching is realized by switching the bit order for data write to SIO0. The SIO0 shift order remains unchanged.

Thus, switching between MSB-first and LSB-first must be performed before writing data to the shift register.

(5) Transfer start

Serial transfer is started by setting transfer data to the serial I/O shift register 0 (SIO0) when the following two conditions are satisfied.

- Serial interface channel 0 operation control bit (CSIE0) = 1.
- Internal serial clock is stopped or $\overline{\text{SCK0}}$ is a high level after 8-bit serial transfer.

Caution If CSIE0 is set to "1" after data write to SIO0, transfer does not start.

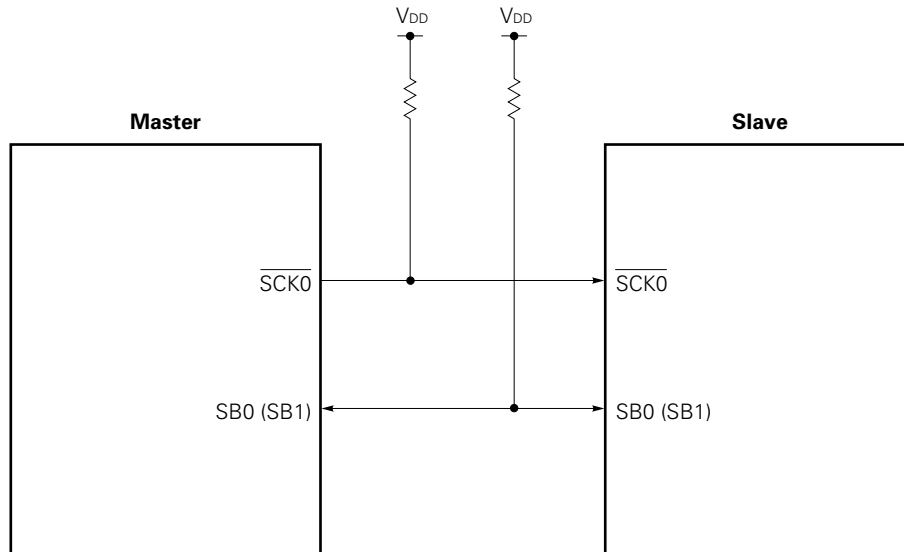
Upon termination of 8-bit transfer, serial transfer automatically stops and the interrupt request flag (CSIF0) is set.

16.4.3 2-wire serial I/O mode operation

The 2-wire serial I/O mode can cope with any communication format by program.

Communication is basically carried out with two lines of serial clock ($\overline{\text{SCK0}}$) and serial data input/output (SB0 or SB1).

Figure 16-10. Serial Bus Configuration Example Using 2-Wire Serial I/O Mode



(1) Register setting

The 2-wire serial I/O mode is set with the serial operating mode register 0 (CSIM0), the serial bus interface control register (SBIC), and the interrupt timing specify register (SINT).

(a) Serial operating mode register 0 (CSIM0)

CSIM0 is set with a 1-bit or 8-bit memory manipulation instruction.

RESET input sets CSIM0 to 00H. The shaded area is used in the 2-wire serial I/O mode.

Symbol	⑦	⑥	⑤	4	3	2	1	0	Address	After Reset	R/W
CSIM0	CSIE0	COI	WUP	CSIM04	CSIM03	CSIM02	CSIM01	CSIM00	FF60H	00H	R/W ^{Note 1}

R/W	CSIM01	CSIM00	Serial Interface Channel 0 Clock Selection
	0	×	Input Clock to SCK0 pin from off-chip
	1	0	8-bit timer register 2 (TM2) output
	1	1	Clock specified with bits 0 to 3 of timer clock select register 3 (TCL3)

R/W	CSIM04	CSIM03	CSIM02	PM25	P25	PM26	P26	PM27	P27	Operation Mode	Start Bit	SIO/SB0/SDA0 /P25 Pin Function	SO0/SB1/SDA1 /P26 Pin Function	SCK0/SCL/P27 Pin Function
	0	×	3-wire Serial I/O mode (See Section 16.4.2, "3-wire serial I/O mode operation")											
	1	1	0	×	×	0	0	0	1	2-wire serial I/O mode or I ² C bus mode	MSB	P25 (CMOS input/output)	SB1/SDA1 (N-ch open-drain input/output)	SCK0/SCL (N-ch open-drain input/output)
			1	0	0	×	×	0	1			SB0/SDA0 (N-ch open-drain input/output)	P26 (CMOS input/output)	

R/W	WUP	Wake-up Function Control ^{Note 3}
	0	Interrupt request signal generation with each serial transfer in any mode
	1	Interrupt request signal generation when the address received after detecting start condition (when CMDD=1) matches the slave address register data in I ² C bus mode

R	COI	Slave Address Comparison Result Flag ^{Note 4}
	0	Slave address register not equal to serial I/O shift register 0 data
	1	Slave address register equal to serial I/O shift register 0 data

R/W	CSIE0	Serial Interface Channel 0 Operation Control
	0	Operation stopped
	1	Operation enabled

- Notes**
1. Bit 6 (COI) is a read-only bit.
 2. Can be used freely as port function.
 3. Be sure to set WUP to 0 when the 2-wire serial I/O mode.
 4. When CSIE0=0, COI becomes 0.

Remark × : don't care

(b) Serial bus interface control register (SBIC)

SBIC is set with a 1-bit or 8-bit memory manipulation instruction.

$\overline{\text{RESET}}$ input sets SBIC to 00H. The shaded area is used in the 2-wire serial I/O mode.

Symbol	⑦	⑥	⑤	④	③	②	①	①	①	Address	After Reset	R/W
SBIC	BSYE	ACKD	ACKE	ACKT	CMDD	RELD	CMDT	RELT		FF61H	00H	R/W

R/W	RELT	When RELT = 1, SO latch is set to 1. After SO latch setting, automatically cleared to 0. Also cleared to 0 when CSIE0 = 0.
-----	------	--

R/W	CMDT	When CMDT = 1, SO latch is cleared to 0. After SO latch clearance, automatically cleared to 0. Also cleared to 0 when CSIE0 = 0.
-----	------	--

www.DataSheet4U.com

(c) Interrupt timing specify register (SINT)

SINT is set with a 1-bit or 8-bit memory manipulation instruction.

$\overline{\text{RESET}}$ input sets SINT to 00H.

The shaded area is used in the 2-wire serial I/O mode.

Symbol	7	⑥	⑤	④	③	②	1	0	Address	After Reset	R/W
SINT	0	CLD	SIC	SVAM	CLC	WREL	WAT1	WAT0	FF63H	00H	R/W ^{Note 1}

R/W	SIC	INTCSI0 Interrupt Factor Selection
0		CSIIF0 is set upon termination of serial interface channel 0 transfer
1		CSIIF0 is set upon stop condition detection or termination of serial interface channel 0 transfer

R	CLD	$\overline{\text{SCK0}}$ Pin Level ^{Note 2}
0		Low level
1		High level

- Notes**
1. Bit 6 (CLD) is a read-only bit.
 2. When CSIE0 = 0, CLD becomes 0.

Caution Be sure to set bit 0 to bit 3 to 0 when 2-wire serial I/O mode is used.

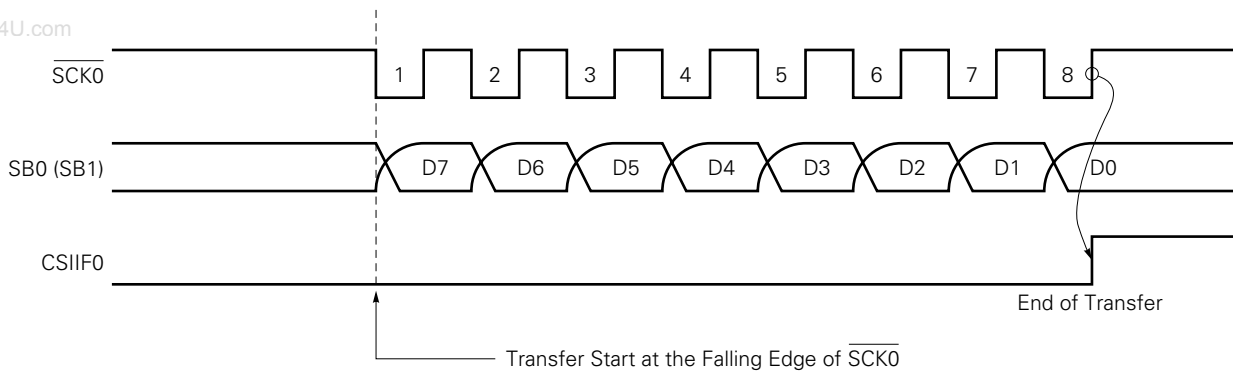
(2) Communication operation

The 2-wire serial I/O mode is used for data transmission/reception in 8-bit units. Data transmission/reception is carried out bit-wise in synchronization with the serial clock.

Shift operation of the serial I/O shift register 0 (SIO0) is carried out in synchronization with the falling edge of the serial clock ($\overline{\text{SCK0}}$). The transmit data is held in the SO0 latch and is output from the SB0/SDA0/P25 (or SB1/SDA1/P26) pin on an MSB-first basis. The receive data input from the SB0 (or SB1) pin is latched into the shift register at the rising edge of $\overline{\text{SCK0}}$.

Upon termination of 8-bit transfer, the shift register operation stops automatically and the interrupt request flag (CSIF0) is set.

Figure 16-11. 2-Wire Serial I/O Mode Timings



The SB0 (or SB1) pin specified for the serial data bus is an N-ch open-drain input/output and thus it must be externally connected to a pull-up resistor. Because it is necessary to turn off the N-ch transistor for data reception, write FFH to SIO0 in advance.

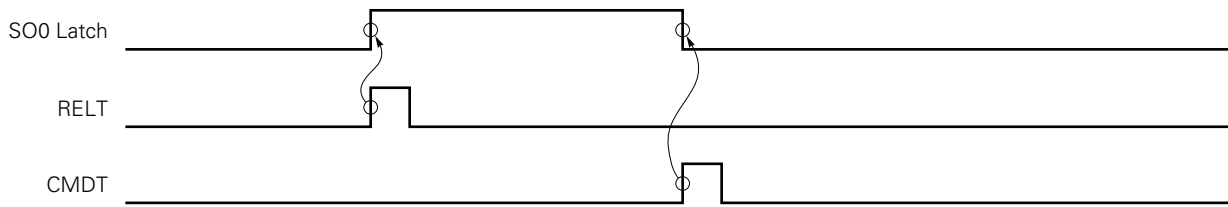
The SB0 (or SB1) pin generates the SO0 latch status and thus the SB0 (or SB1) pin output status can be manipulated by setting the RELT and CMDT bits. However, do not carry out this manipulation during serial transfer.

Control the $\overline{\text{SCK0}}$ pin output level in the output mode (internal system clock mode) by manipulating the P27 output latch (refer to **16.4.6 $\overline{\text{SCK0}}$ /SCL/P27 pin output manipulation**).

(3) Other signals

Figure 16-12 shows RELT and CMDT operations.

Figure 16-12. RELT and CMDT Operations



www.DataSheet4U.com

(4) Transfer start

Serial transfer is started by setting transfer data to the serial I/O shift register 0 (SIO0) when the following two conditions are satisfied.

- Serial interface channel 0 operation control bit (CSIE0) = 1
- Internal serial clock is stopped or $\overline{\text{SCK0}}$ is at high level after 8-bit serial transfer

Cautions 1. If CSIE0 is set to "1" after data write to SIO0, transfer does not start.

2. Because the N-ch transistor must be turned off for data reception, write FFH to SIO0 in advance.

Upon termination of 8-bit transfer, serial transfer automatically stops and the interrupt request flag (CSIF0) is set.

(5) Error detection

In the 2-wire serial I/O mode, the serial bus SB0 (SB1) status being transmitted is fetched into the destination device, that is, SIO0. Thus, transmit error can be detected in the following way.

(a) Method of comparing SIO0 data before transmission to that after transmission

In this case, if two data differ from each other, a transmit error is judged to have occurred.

(b) Method of using the slave address register (SVA)

Transmit data is set to both SIO0 and SVA and is transmitted. After termination of transmission, COI bit (match signal coming from the address comparator) of the serial operating mode register 0 (CSIM0) is tested. If "1", normal transmission is judged to have been carried out. If "0", a transmit error is judged to have occurred.

16.4.4 I²C bus mode operation

The I²C bus mode is provided for when communication operations are performed between a single master device and multiple slave devices. This mode configures a serial bus that includes only a single master device, and is based on the clocked serial I/O format with the addition of bus configuration functions, which allows the master device to communicate with a number of (slave) devices using only two lines: serial clock (SCL) line and serial data bus (SDA0 or SDA1) line. Consequently, when the user plans to configure a serial bus which includes multiple microcontrollers and peripheral devices, using this configuration results in reduction of the required number of port pins and on-board wires.

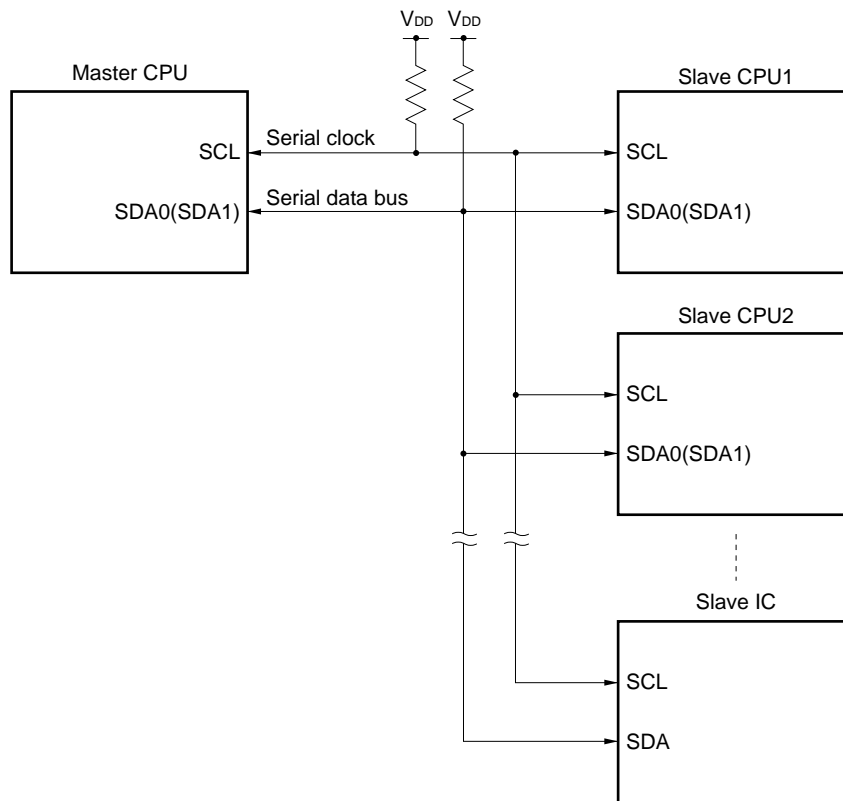
In the I²C bus specification, the master sends start condition, data, and stop condition signals to slave devices through the serial data bus, while slave devices automatically detect and distinguish the type of signals due to the signal detection function incorporated as hardware. This simplifies I²C bus control sections in the application program.

An example of a serial bus configuration is shown in Figure 16-13. This system below is composed of CPUs and peripheral ICs having serial interface hardware that complies with the I²C bus specification.

Note that pull-up resistors are required to connect to both serial clock line and serial data bus line, because open-drain buffers are used for the serial clock pin (SCL) and the serial data bus pin (SDA0 or SDA1) on the I²C bus.

The signals used in the I²C bus mode are described in Table 16-4.

Figure 16-13. Example of Serial Bus Configuration Using I²C Bus



(1) I²C bus mode functions

In the I²C bus mode, the following functions are available.

(a) Automatic identification of serial data

Slave devices automatically detect and identifies start condition, data, and stop condition signals sent in series through the serial data bus.

(b) Chip selection by specifying device addresses

The master device can select a specific slave device connected to the I²C bus and communicate with it by sending in advance the address data corresponding to the destination device.

(c) Wake-up function

When address data is sent from the master device, slave devices compare it with the value registered in their internal slave address registers. If the values in one of the slave devices match, the slave device internally generates an interrupt signal to terminate the current processing and communicates with the master device. Therefore, CPUs other than the selected slave device on the I²C bus can perform independent operations during the serial communication.

(d) Acknowledge signal ($\overline{\text{ACK}}$) control function

The master device and a slave device send and receive acknowledge signals to confirm that the serial communication has been executed normally.

(e) Wait signal ($\overline{\text{WAIT}}$) control function

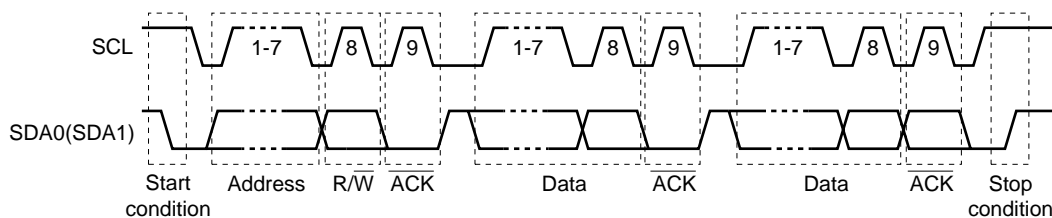
When a slave device is preparing for data transmission or reception and requires more waiting time, the slave device outputs a wait signal on the bus to inform the master device of the wait status.

(2) I²C bus definition

This section describes the format of serial data communications and functions of the signals used in the I²C bus mode.

First, the transfer timings of the start condition, data, and stop condition signals, which are output onto the signal data bus of the I²C bus, are shown in Figure 16-14.

Figure 16-14. I²C Bus Serial Data Transfer Timing



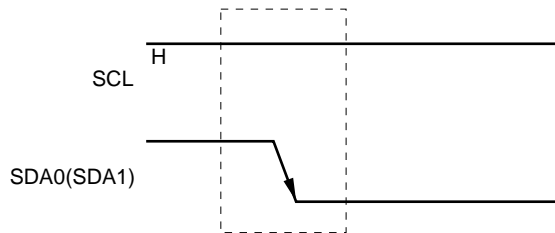
The start condition, slave address, and stop condition signals are output by the master. The acknowledge signal ($\overline{\text{ACK}}$) is output by either the master or the slave device (normally by the device which has received the 8-bit data that was sent). A serial clock (SCL) is continuously supplied from the master device.

(a) Start condition

When the SDA0 (SDA1) pin level is changed from high to low while the SCL pin is high, this transition is recognized as the start condition signal. This start condition signal, which is created using the SCL and SDA0 (or SDA1) pins, is output from the master device to slave devices to initiate a serial transfer. See section 16.4.5, "Cautions on Use of I²C Bus Mode," for details of the start condition output.

The start condition signal is detected by hardware incorporated in slave devices.

Figure 16-15. Start Condition



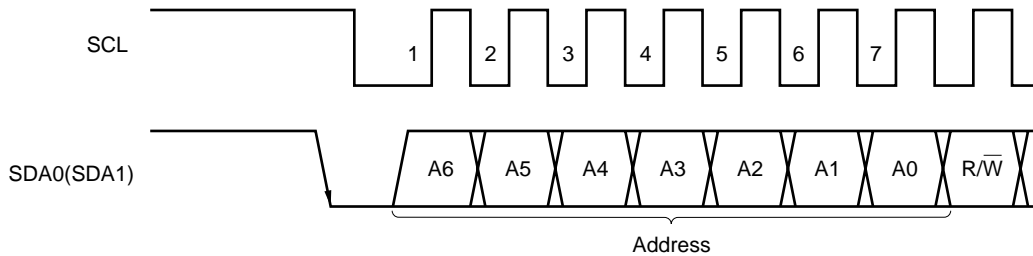
(b) Address

The 7 bits following the start condition signal are defined as an address.

The 7-bit address data is output by the master device to specify a specific slave from among those connected to the bus line. Each slave device on the bus line must therefore have a different address.

Therefore, after a slave device detects the start condition, it compares the 7-bit address data received and the data of the slave address register (SVA). After the comparison, only the slave device in which the data are a match becomes the communication partner, and subsequently performs communication with the master device until the master device sends a start condition or stop condition signal.

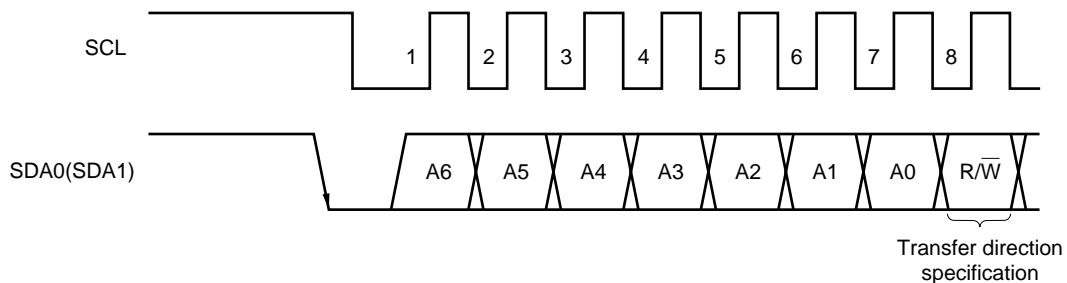
Figure 16-16. Address



(c) Transfer direction specification

The 1 bit that follows the 7-bit address data will be sent from the master device, and it is defined as the transfer direction specification bit. If this bit is 0, it is the master device which will send data to the slave. If it is 1, it is the slave device which will send data to the master.

Figure 16-17. Transfer Direction Specification



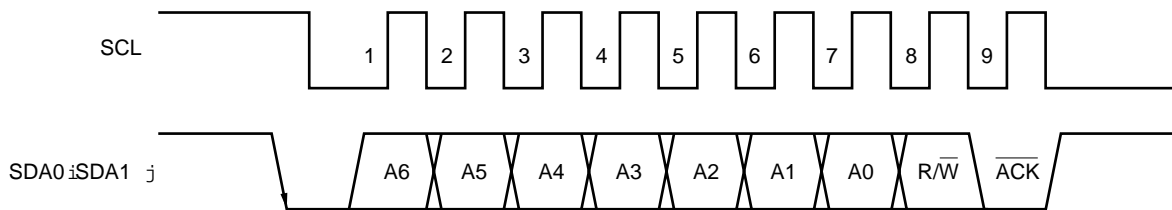
(d) Acknowledge signal ($\overline{\text{ACK}}$)

The acknowledge signal indicates that the transferred serial data has definitely been received. This signal is used between the sending side and receiving side devices for confirmation of correct data transfer. In principle, the receiving side device returns an acknowledge signal to the sending device each time it receives 8-bit data. The only exception is when the receiving side is the master device and the 8-bit data is the last transfer data; the master device outputs no acknowledge signal in this case.

The sending side that has transferred 8-bit data waits for the acknowledge signal which will be sent from the receiving side. If the sending side device receives the acknowledge signal, which means a successful data transfer, it proceeds to the next processing. If this signal is not sent back from the slave device, this means that the data sent has not been received by the slave device, and therefore the master device outputs a stop condition signal to terminate subsequent transmissions.

www.DataSheet4U.com

Figure 16-18. Acknowledge Signal



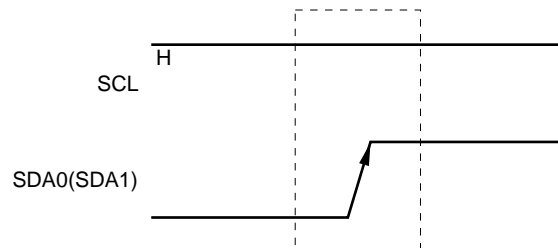
(e) Stop condition

If the SDA0 (SDA1) pin level changes from low to high while the SCL pin is high, this transition is defined as a stop condition signal.

The stop condition signal is output from the master to the slave device to terminate a serial transfer.

The stop condition signal is detected by hardware incorporated in the slave device.

Figure 16-19. Stop Condition



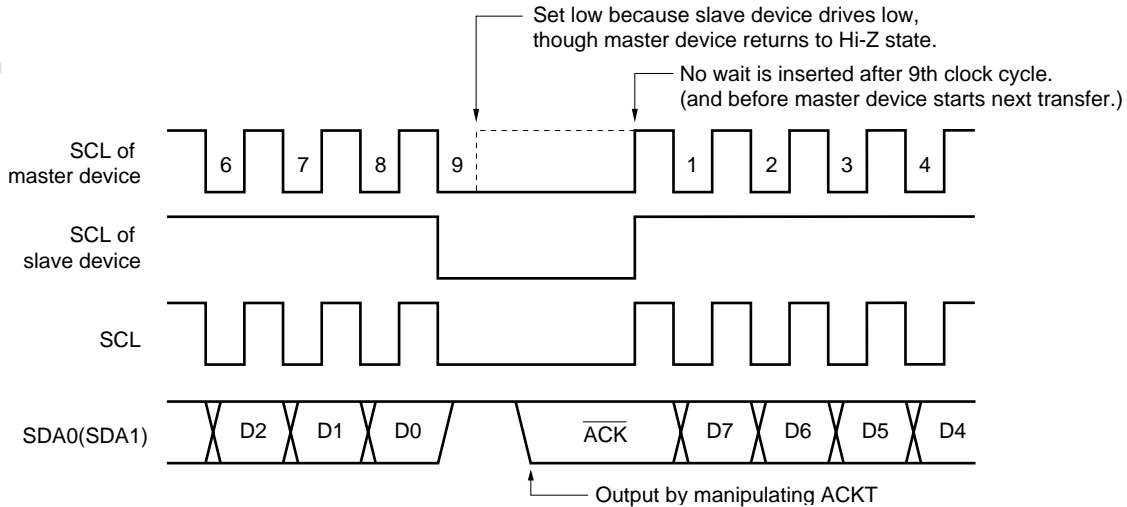
(f) Wait signal ($\overline{\text{WAIT}}$)

The wait signal is output by a slave device to inform the master device that the slave device is in wait state due to preparing for transmitting or receiving data.

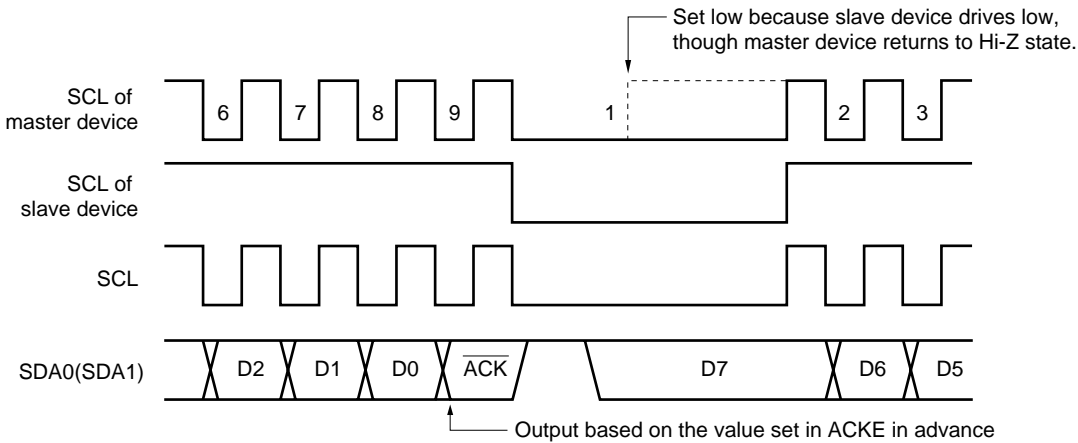
During the wait state, the slave device continues to output the wait signal by keeping the SCL pin low to delay subsequent transfers. When the wait state is released, the master device can start the next transfer. For the releasing operation of slave devices, see section 16.4.5, "Cautions on Use of I²C Bus Mode."

Figure 16-20. Wait Signal

(a) Wait of 8 Clock Cycles



(b) Wait of 9 Clock Cycles



(3) Register setting

The I²C mode setting is performed by the serial operating mode register 0 (CSIM0), the serial bus interface control register (SBIC), and the interrupt timing specify register (SINT).

(a) Serial operating mode register 0 (CSIM0)

CSIM0 is set by a 1-bit or 8-bit memory manipulation instruction.

RESET input sets 00H.

The CSIM0 format is shown below, where the bits used in the I²C bus mode are shaded.

Symbol	⑦	⑥	⑤	4	3	2	1	0	Address	After Reset	R/W
CSIM0	CSIE0	COI	WUP	CSIM04	CSIM03	CSIM02	CSIM01	CSIM00	FF60H	00H	R/W ^{Note 1}

R/W	CSIM01	CSIM00	Serial Interface Channel 0 Clock Selection											
	0	x	Input clock from off-chip to SCL pin											
	1	0	8-bit timer register 2 (TM2) output ^{Note 2}											
	1	1	Clock specified with bits 0 to 3 of timer clock select register 3 (TCL3)											
R/W	CSIM04	CSIM03	CSIM02	PM25	P25	PM26	P26	PM27	P27	Operation mode	Start bit	SI0/SB0/SDA0/P25 pin function	SO0/SB1/SDA1/P26 pin function	SCK0/SCL/P27 pin function
	0	x	3-wire serial I/O mode (see section 16.4.2 "3-wire serial I/O mode operation")											
	1	1	0	x ^{Note3}	x ^{Note3}	0	0	0	1	2-wire serial I/O or I ² C bus mode	MSB	P25 (CMOS I/O)	SB1/SDA1 (N-ch open-drain I/O)	SCK0/SCL (N-ch open-drain I/O)
	1	1	1	0	0	x ^{Note3}	x ^{Note3}	0	1	2-wire serial I/O or I ² C bus mode	MSB	SB0/SDA0 (N-ch open-drain I/O)	P26 (CMOS I/O)	SCK0/SCL (N-ch open-drain I/O)
R/W	WUP	Wake-up Function Control												
	0	Interrupt request signal generation with each serial transfer in any mode												
	1	In I ² C bus mode, interrupt request signal is generated when the address data received after start condition detection (when CMDD = 1) matches data in slave address register.												
R	COI	Slave Address Comparison Result Flag ^{Note 4}												
	0	Slave address register not equal to data in serial I/O shift register 0												
	1	Slave address register equal to data in serial I/O shift register 0												
R/W	CSIE0	Serial Interface Channel 0 Operation Control												
	0	Stops operation.												
	1	Enables operation.												

Notes 1. Bit 6 (COI) is a read-only bit.

2. In the I²C bus mode, the clock frequency is 1/16 of the clock frequency output by TO2.

3. Can be used freely as a port.

4. When CSIE0 = 0, COI is 0.

Remark: x: Don't care

(b) Serial bus interface control register (SBIC)

SBIC is set by a 1-bit or 8-bit memory manipulation instruction.

RESET input sets SBIC to 00H.

The SBIC format is shown below, where the bits used in the I²C bus mode are shaded.

Symbol	⑦	⑥	⑤	④	③	②	①	①	Address	After Reset	R/W
SBIC	BSYE	ACKD	ACKE	ACKT	CMDD	RELD	CMDT	RELT	FF61H	00H	R/W ^{Note 1}
R/W	RELT	Use for stop condition output. When RELT = 1, SO latch is set to 1. After SO latch setting, automatically cleared to 0. Also cleared to 0 when CSIE0 = 0.									
R/W	CMDT	Use for start condition output. When CMDT = 1, SO latch is cleared to 0. After clearing SO latch, automatically cleared to 0. Also cleared to 0 when CSIE0 = 0.									
R	RELD	Stop Condition Detection									
	0	Clear Conditions <ul style="list-style-type: none"> • When transfer start instruction is executed • If SIO0 and SVA values do not match in address reception • When CSIE0 = 0 • When RESET input is applied 									
	1	Setting Condition <ul style="list-style-type: none"> • When stop condition is detected 									
R	CMDD	Start Condition Detection									
	0	Clear Conditions <ul style="list-style-type: none"> • When transfer start instruction is executed • When stop condition is detected • When CSIE0 = 0 • When RESET input is applied 									
	1	Setting Condition <ul style="list-style-type: none"> • When start condition is detected 									
R/W	ACKT	SDA0 (SDA1) is set to low after the Set instruction execution (ACKT = 1) before the next SCL falling edge. Used for generating an ACK signal by software if the 8-clock wait mode is selected. Cleared to 0 if CSIE0 = 0 when a transfer by the serial interface is started.									
R/W	ACKE	Acknowledge Signal Automatic Output Control ^{Note 2}									
	0	Disabled (with ACKT enabled). Used when receiving data in the 8-clock wait mode or when transmitting data ^{Note 3} .									
	1	Enabled. After completion of transfer, acknowledge signal is output in synchronization with the 9th falling edge of SCL clock (automatically output when ACKE = 1). However, not automatically cleared to 0 after acknowledge signal output. Used for reception when the 9-clock wait mode is selected.									
R	ACKD	Acknowledge Detection									
	0	Clear Conditions <ul style="list-style-type: none"> • When transfer start instruction is executed • When CSIE0 = 0 • When RESET input is applied 									
	1	Set Conditions <ul style="list-style-type: none"> • When acknowledge signal is detected at the rising edge of SCL clock after completion of transfer 									
R/W	^{Note 4} BSYE	Control of N-ch Open-Drain Output for Transmission in I ² C Bus Mode ^{Note 5}									
	0	Output enabled (transmission)									
	1	Output disabled (reception)									

- Notes**
1. Bits 2, 3, and 6 (RELD, CMDD, ACKD) are read-only bits.
 2. This setting must be performed prior to transfer start.
 3. In the 8-clock wait mode, use ACKT for output of the acknowledge signal after normal data reception.
 4. The busy mode can be released by the start of a serial interface transfer or reception of an address signal. However, the BSYE flag is not cleared.
 5. When using the wake-up function, be sure to set BSYE to 1.

(c) Interrupt timing specification register (SINT)

SINT is set by the 1-bit or 8-bit memory manipulation instruction.

RESET input sets SINT to 00H.

The SINT format is shown below, where the bits used in the I²C bus mode are shaded.

Symbol	7	⑥	⑤	④	③	②	1	0	Address	After Reset	R/W
SINT	0	CLD	SIC	SVAM	CLC	WREL	WAT1	WAT0	FF63H	00H	R/W ^{Note 1}

R/W	WAT1	WAT0	Interrupt control by wait Note 2
	0	0	Interrupt service request is generated on rise of 8th SCK0 clock cycle (clock output is high impedance).
	0	1	Setting prohibited
	1	0	Used in I ² C bus mode (8-clock wait) Generates an interrupt service request on rise of 8th SCL clock cycle. (In case of master device, SCL pin is driven low after output of 8 clock cycles, to enter the wait state. In case of slave device, SCL pin is driven low after input of 8 clock cycles, to require the wait state.)
R/W	1	1	Used in I ² C bus mode (9-clock wait) Generates an interrupt service request on rise of 9th SCL clock cycle. (In case of master device, SCL pin is driven low after output of 9 clock cycles, to enter the wait state. In case of slave device, SCL pin is driven low after input of 9 clock cycles, to require the wait state.)
	WREL	Wait release control	
R/W	0	Indicates that the wait state has been released.	
	1	Releases the wait state. Automatically cleared to 0 after releasing the wait state. This bit is used to release the wait state set by means of WAT0 and WAT1.	
R/W	CLC	Clock level control	
	0	Used in I ² C bus mode. In cases other than serial transfer, SCL pin output is driven low.	
R/W	1	Used in I ² C bus mode. In cases other than serial transfer, SCL pin output is set to high impedance. (Clock line is held high.) Used by master device to generate the start condition and stop condition signals.	
	SVAM	SVA bits used as slave address	
R/W	0	Bits 0 to 7	
	1	Bits 1 to 7	
R/W	SIC	INTCSI0 interrupt source selection Note 3	
	0	CSIIF0 is set to 1 after end of serial interface channel 0 transfer.	
R	1	CSIIF0 is set to 1 after end of serial interface channel 0 transfer or when stop condition is detected.	
	CLD	SCL pin level Note 4	
R	0	Low level	
	1	High level	

- Notes**
1. Bit 6 (CLD) is read-only.
 2. When the I²C bus mode is used, be sure to set 1 and 0, or 1 and 1 in WAT0 and WAT1, respectively.
 3. When using the wake-up function in I²C mode, be sure to set SIC to 1.
 4. When CSIE0 = 0, CLD is 0.

Remark SVA: Slave address register

(4) Various signals

A list of signals in the I²C bus mode is given in Table 16-4.

Table 16-4. Signals in I²C Bus Mode

Signal name	Description
Start condition	Definition : SDA0 (SDA1) falling edge when SCL is high Note 1
	Function : Indicates that serial communication starts and subsequent data are address data.
	Signaled by : Master
	Signaled when : CMDT is set.
	Affected flag(s) : CMDD (is set.)
Stop condition	Definition : SDA0 (SDA1) rising edge when SCL is high Note 1
	Function : Indicates end of serial transmission.
	Signaled by : Master
	Signaled when : RELT is set.
	Affected flag(s) : RELD (is set) and CMDD (is cleared)
Acknowledge signal (ACK)	Definition : Low level of SDA0(SDA1) pin during one SCL clock cycle after serial reception
	Function : Indicates completion of reception of 1 byte.
	Signaled by : Master or slave
	Signaled when : ACKT is set with ACKE = 1.
	Affected flag(s) : ACKD (is set.)
Wait (WAIT)	Definition : Low-level signal output to SCL
	Function : Indicates state in which serial reception is not possible.
	Signaled by : Slave
	Signaled when : WAT1, WAT0 = 1x.
	Affected flag(s) : None
Serial Clock (SCL)	Definition : Synchronization clock for output of various signals
	Function : Serial communication synchronization signal.
	Signaled by : Master
	Signaled when : See Note 2 below.
	Affected flag(s) : CSIF0. Also see Note 3 below.
Address (A6 to A0)	Definition : 7-bit data synchronized with SCL immediately after start condition signal
	Function : Indicates address value for specification of slave on serial bus.
	Signaled by : Master
	Signaled when : See Note 2 below.
	Affected flag(s) : CSIF0. Also see Note 3 below.
Transfer direction (R/W)	Definition : 1-bit data output in synchronization with SCL after address output
	Function : Indicates whether data transmission or reception is to be performed.
	Signaled by : Master
	Signaled when : See Note 2 below.
	Affected flag(s) : CSIF0. Also see Note 3 below.
Data (D7 to D0))	Definition : 8-bit data synchronized with SCL, not immediately after start condition
	Function : Contains data actually to be sent.
	Signaled by : Master or slave
	Signaled when : See Note 2 below.
	Affected flag(s) : CSIF0. Also see Note 3 below.

Notes 1. The level of the serial clock can be controlled by CLC of SINT.

- 2.** Execution of instruction to write data to SIO0 when CSIE0 = 1 (serial transfer start directive). In the wait state, the serial transfer operation will be started after the wait state is released.
- 3.** If the 8-clock wait is selected when WUP = 0, CSIF0 is set at the rising edge of the 8th clock cycle of SCL. If the 9-clock wait is selected when WUP = 0, CSIF0 is set at the rising edge of the 9th clock cycle of SCL. If WUP = 1, CSIF0 is set only when an address is received and the address matches the slave address register (SVA) value.

(5) Pin configurations

The configurations of the serial clock pin (SCL) and the serial data bus pins (SDA0, SDA1) are shown below.

(a) SCL

Pin for serial clock input/output dual-function pin.

<1> Master N-ch open-drain output

<2> Slave Schmitt input

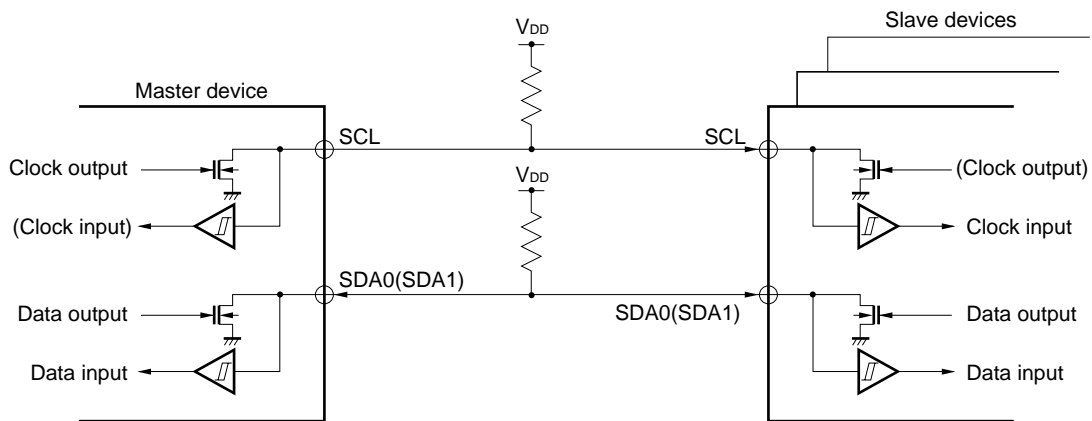
(b) SDA0 (SDA1)

Serial data input/output dual-function pin.

Uses N-ch open-drain output and Schmitt-input buffers for both master and slave devices.

Note that pull-up resistors are required to connect to both serial clock line and serial data bus line, because open-drain buffers are used for the serial clock pin (SCL) and the serial data bus pin (SDA0 or SDA1) on the I²C bus.

Figure 16-21. Pin Configuration



Caution Because the N-ch open-drain output must be disabled during data reception, set BSYE of SBIC to 1 before writing FFH to SIO0.

(6) Address match detection method

In the I²C mode, the master can select a specific slave device by sending slave address data.

Address match detection is performed automatically by the slave device hardware. A slave device address has a slave register (SVA), and compares its contents and the slave address sent from the master device. If they match and the wake-up function specification (WUP) bit is then 1, interrupt request flag (CSIF0) is set.

Caution Be sure to set the WUP bit to 1 before the master device sends slave address data to slave devices. Each slave device recognizes whether the slave device is selected or not by master device by comparing the content of the SVA register (which is in each slave device) and the slave address data, which is sent by master device immediately after the start condition signal. Only if the WUP bit has been set to 1 when they match, the slave device generates INTCSI0 signal.

(7) Error detection

In the I²C bus mode, transmission error detection can be performed by the following methods because the serial bus SDA0 (SDA1) status during transmission is also taken into the SIO0 register of the transmitting device.

(a) Comparison of SIO0 data before and after transmission

In this case, a transmission error is judged to have occurred if the two data values are different.

(b) Using the slave address register (SVA)

Transmit data is set in SIO0 and SVA before transmission is performed. After transmission, the COI bit (match signal from the address comparator) of serial operating mode register 0 (CSIM0) is tested: "1" indicates normal transmission, and "0" indicates a transmission error.

www.DataSheet4U.com

(8) Communication operation

In the I²C bus mode, the master selects the slave device to be communicated with from among multiple devices by outputting address data onto the serial bus.

After the slave address data, the master sends the R/W bit which indicates the data transfer direction, and starts serial communication with the selected slave device.

Data communication timing charts are shown in Figures 16-22 and 16-23.

In the transmitting device, the shift register (SIO0) shifts transmission data to the SO latch in synchronization with the falling edge of the serial clock (SCL), the SO0 latch outputs the data on an MSB-first basis from the SDA0 or SDA1 pin to the receiving device.

In the receiving device, the data input from the SDA0 or SDA1 pin is taken into the shift register (SIO0) in synchronization with the rising edge of SCL.

(9) Start of transfer

A serial transfer is started by setting transfer data in SIO0 if the following two conditions have been satisfied:

- (a) The serial interface channel 0 operation control bit (CSIE0) = 1.
- (b) After an 8-bit serial transfer, the internal serial clock is stopped or SCL is low.

Cautions 1. Be sure to set CSIE0 to 1 before writing data in SIO0. Setting CSIE0 to 1 after writing data in SIO0 does not initiate transfer operation.

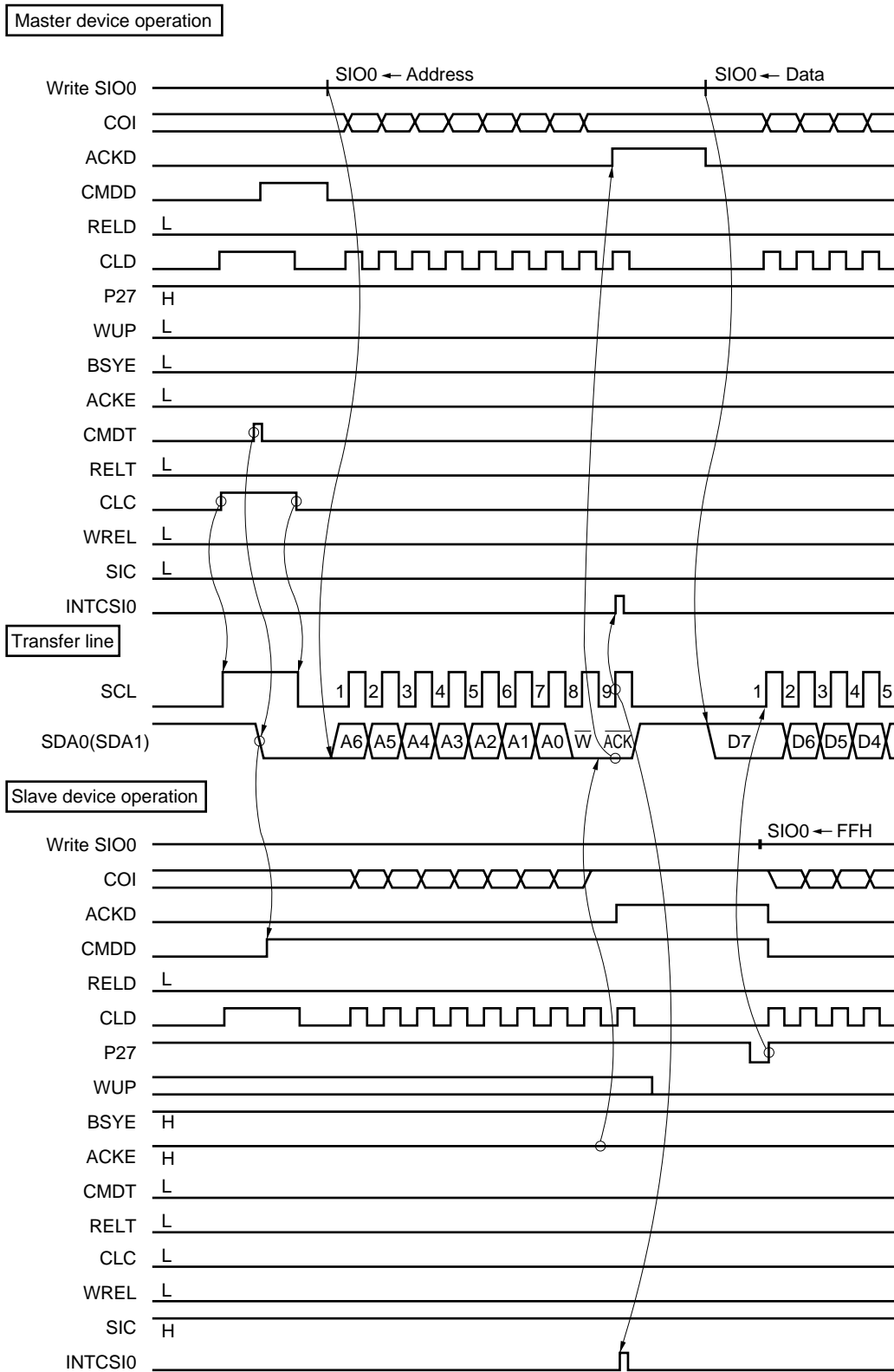
2. Because the N-ch open-drain output must be disabled during data reception, set BSYE of SBIC to 1 before writing FFH to SIO0.

3. If data is written to SIO0 while the slave is in the wait state, that data is held. The transfer is started when SCL is output after the wait state is cleared.

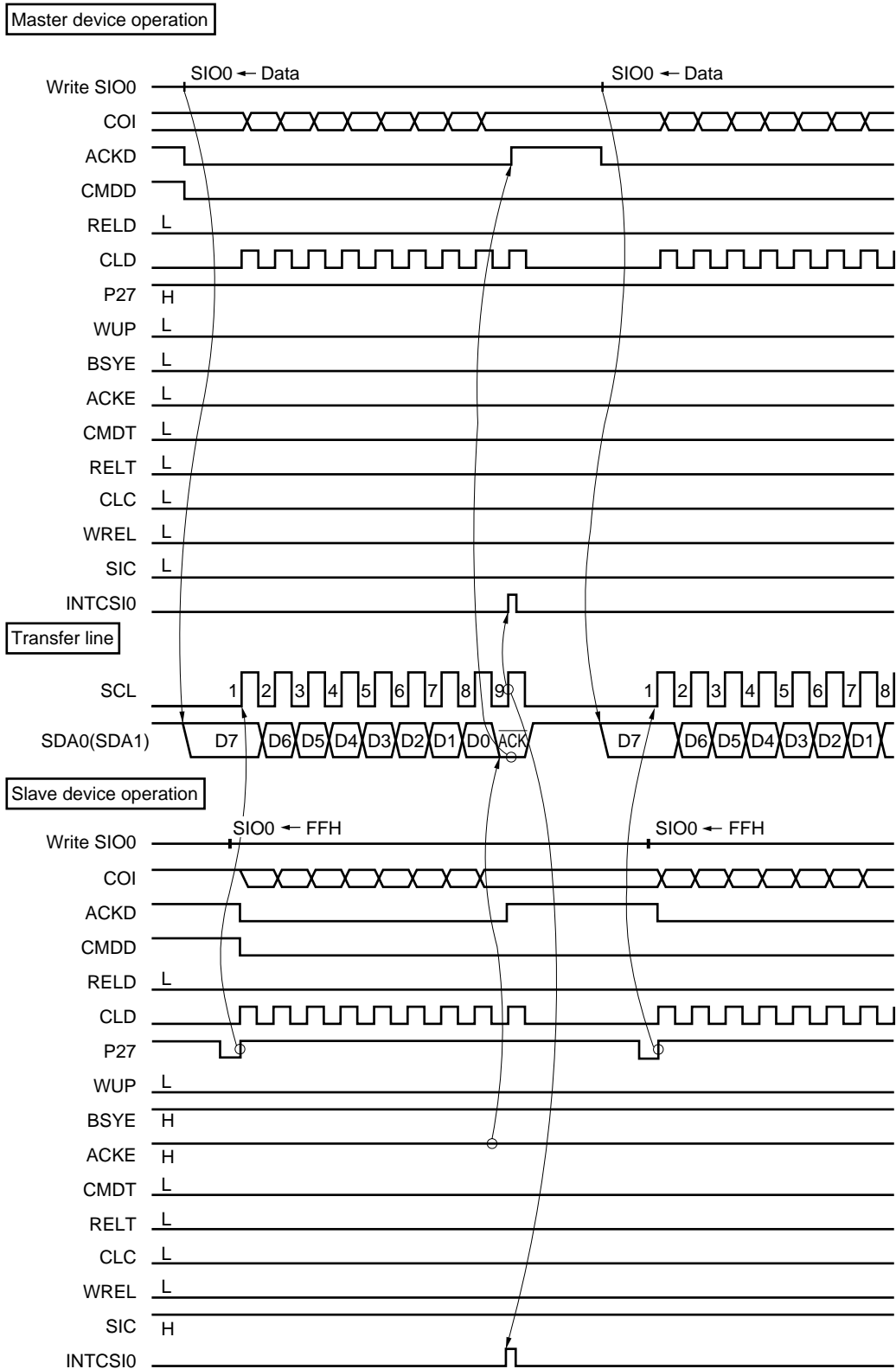
When an 8-bit data transfer ends, serial transfer is stopped automatically and the interrupt request flag (CSIIF0) is set.

**Figure 16-22. Data Transmission from Master to Slave
(Both Master and Slave Selected 9-Clock Wait) (1 of 3)**

(a) Start Condition to Address

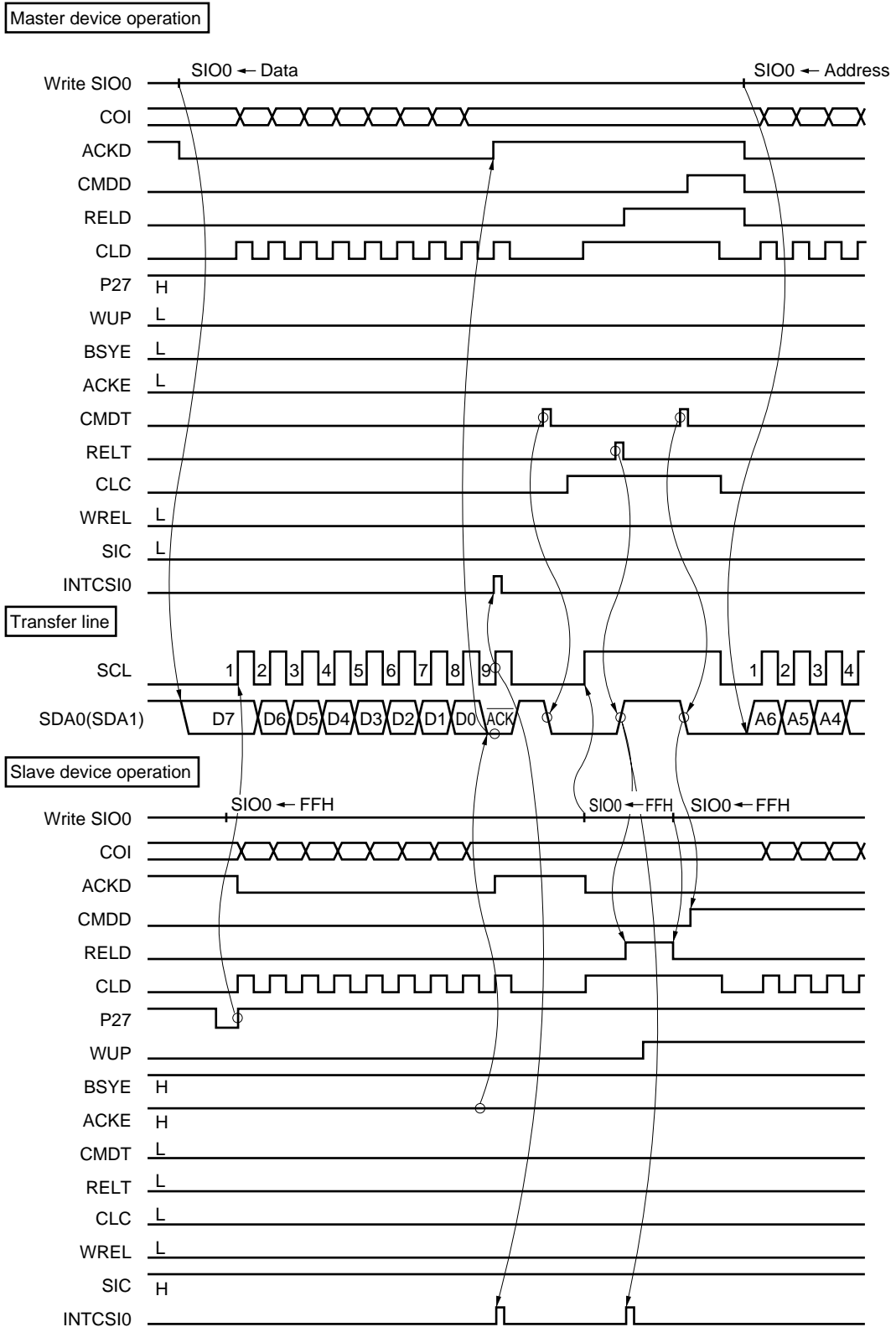


**Figure 16-22. Data Transmission from Master to Slave
(Both Master and Slave Selected 9-Clock Wait) (2 of 3)**
(b) Data

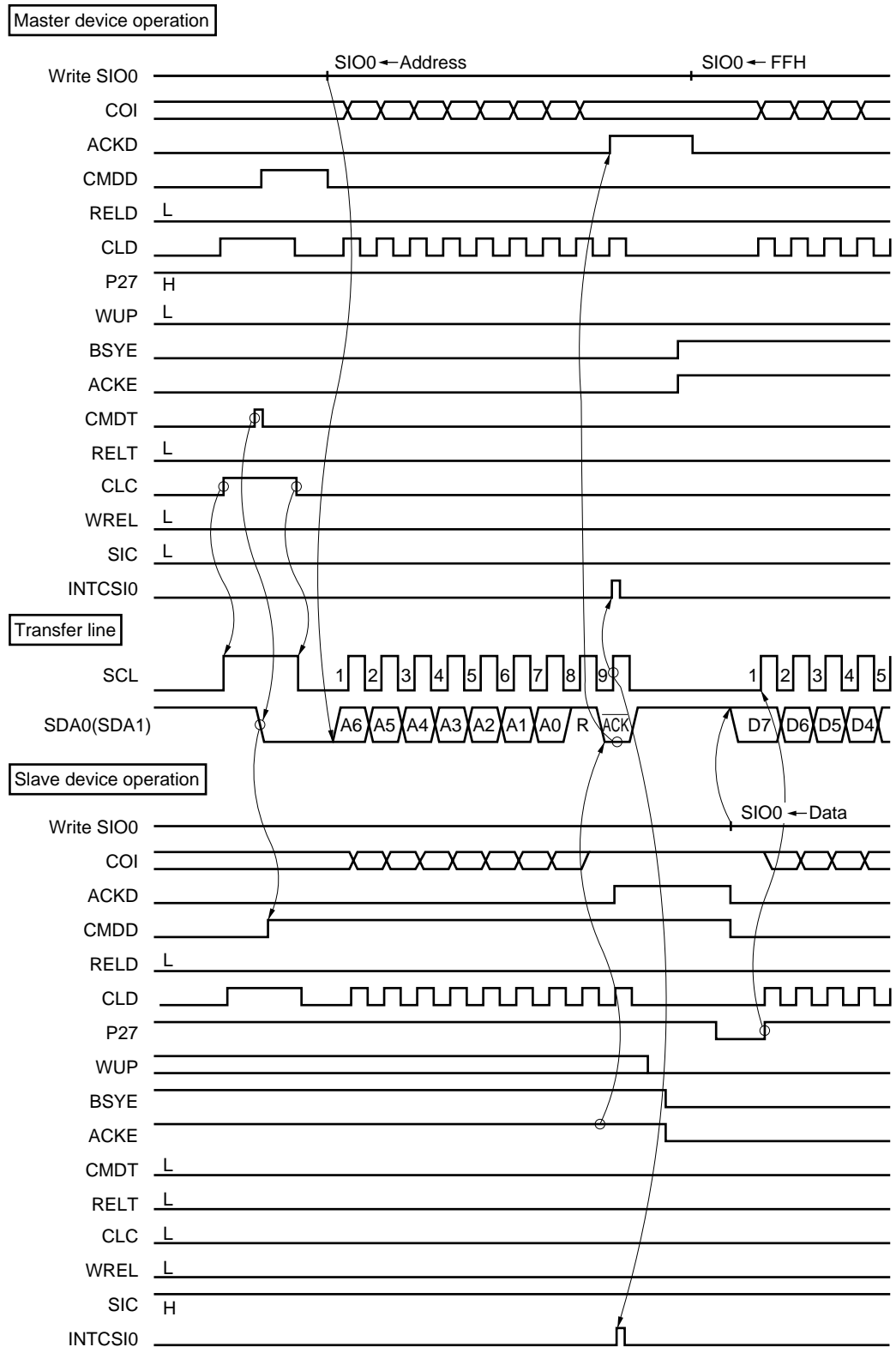


www.DataSheet4U.com

**Figure 16-22. Data Transmission from Master to Slave
(Both Master and Slave Selected 9-Clock Wait) (3 of 3)
(c) Stop Condition**

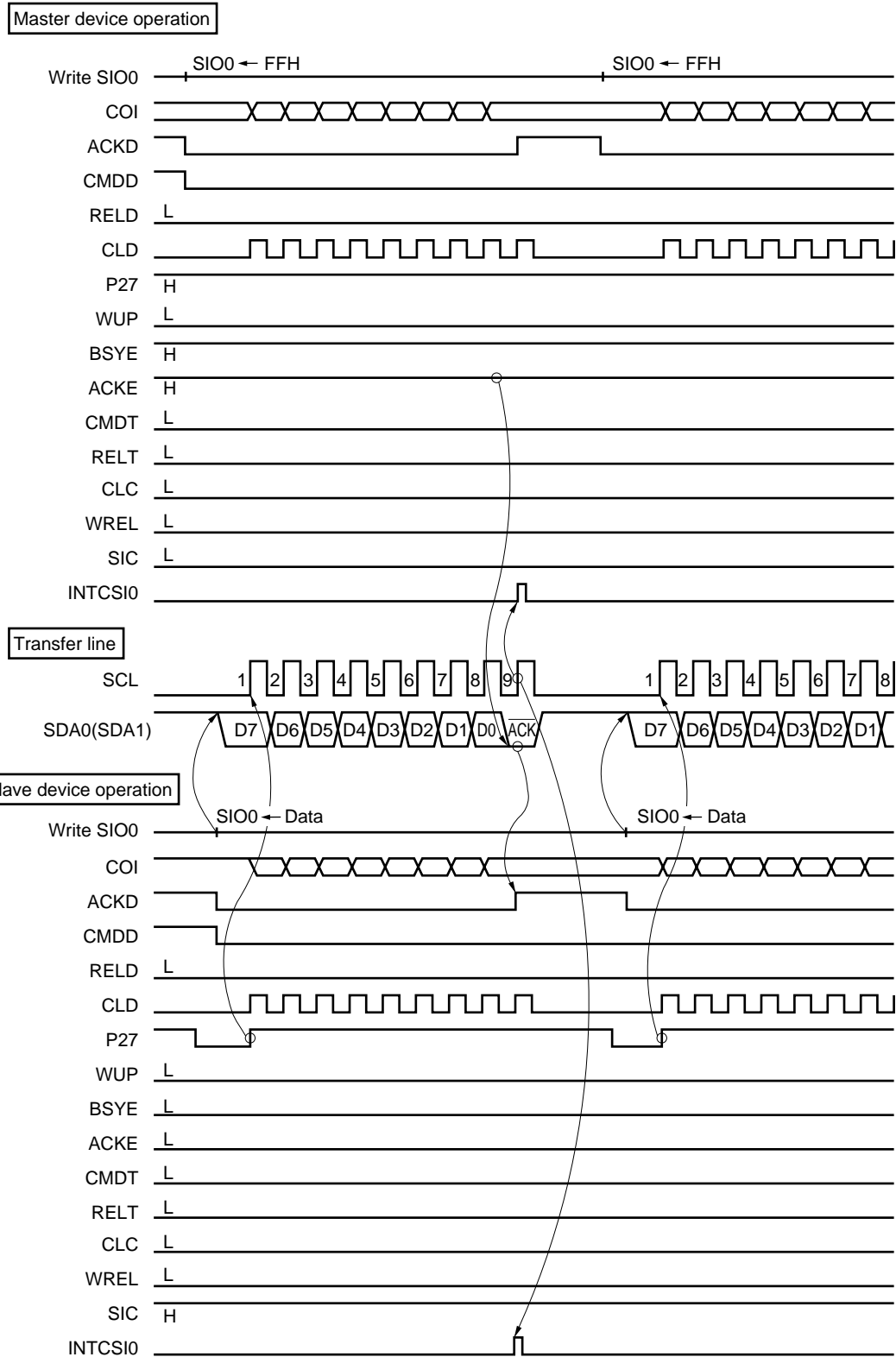


**Figure 16-23. Data Transmission from Slave to Master
(Both Master and Slave Selected 9-Clock Wait) (1 of 3)**
(a) Start Condition to Address

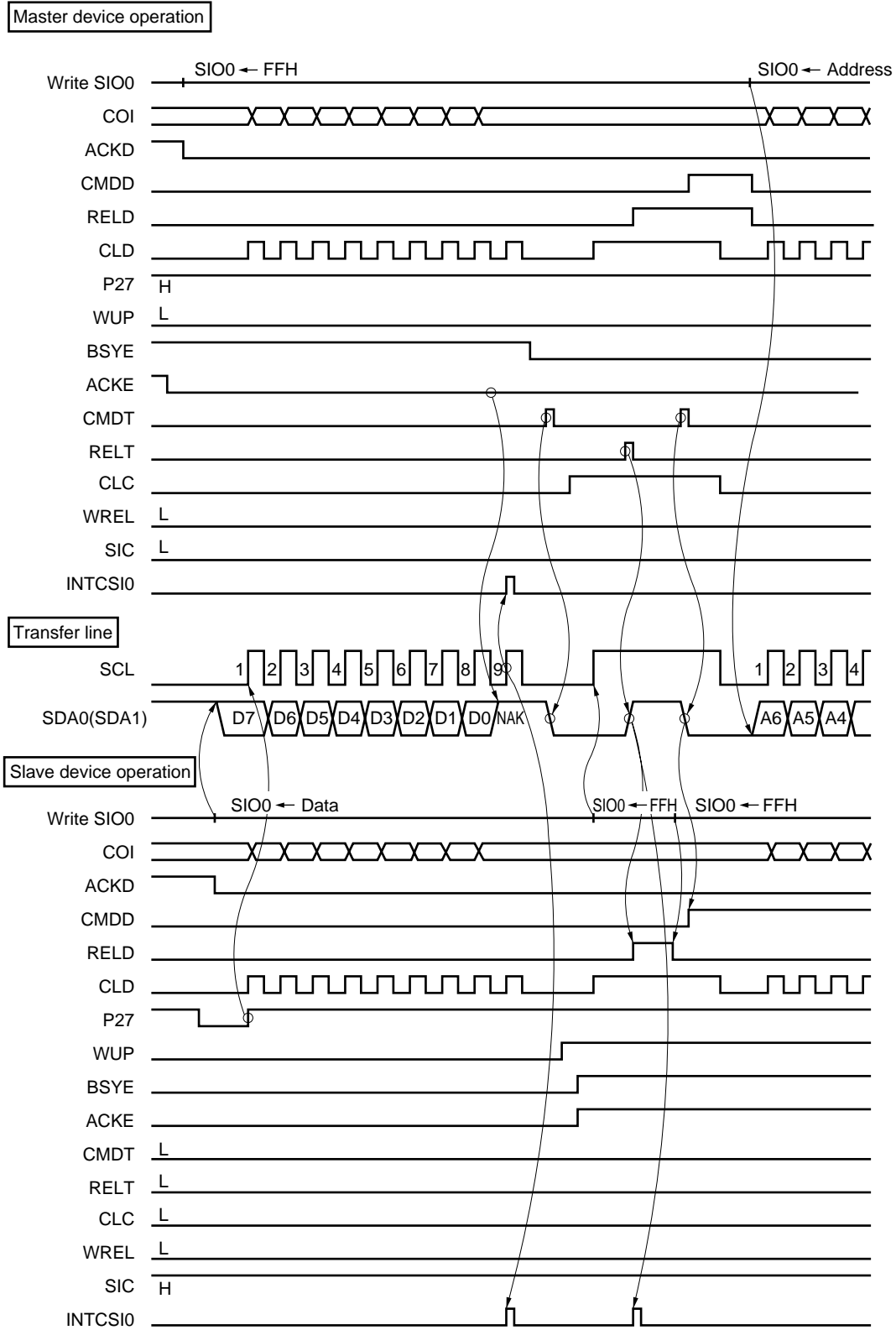


www.DataSheet4U.com

**Figure 16-23. Data Transmission from Slave to Master
(Both Master and Slave Selected 9-Clock Wait) (2 of 3)
(b) Data**



**Figure 16-23. Data Transmission from Slave to Master
(Both Master and Slave Selected 9-Clock Wait) (3 of 3)
(c) Stop Condition**



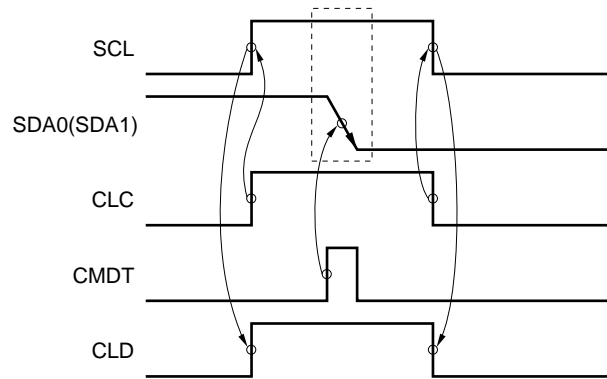
16.4.5 Cautions on use of I²C bus mode

(1) Start condition output (master)

The SCL pin normally outputs a low-level signal when no serial clock is output. It is necessary to change the SCL pin to high in order to output a start condition signal. Set 1 in CLC of SINT to drive the SCL pin high.

After setting CLC, clear CLC to 0 and return the SCL pin to low. If CLC remains 1, no serial clock is output. If it is the master device which outputs the start condition and stop condition signals, confirm that CLD is set to 1 after setting CLC to 1; a slave device may have set SCL to low (wait state).

Figure 16-24. Start Condition Output



(2) Slave wait release (slave transmission)

The wait status of a slave is released by setting the WREL flag, which is bit 2 of the interrupt timing specify register (SINT), or by executing an SIO0 write instruction.

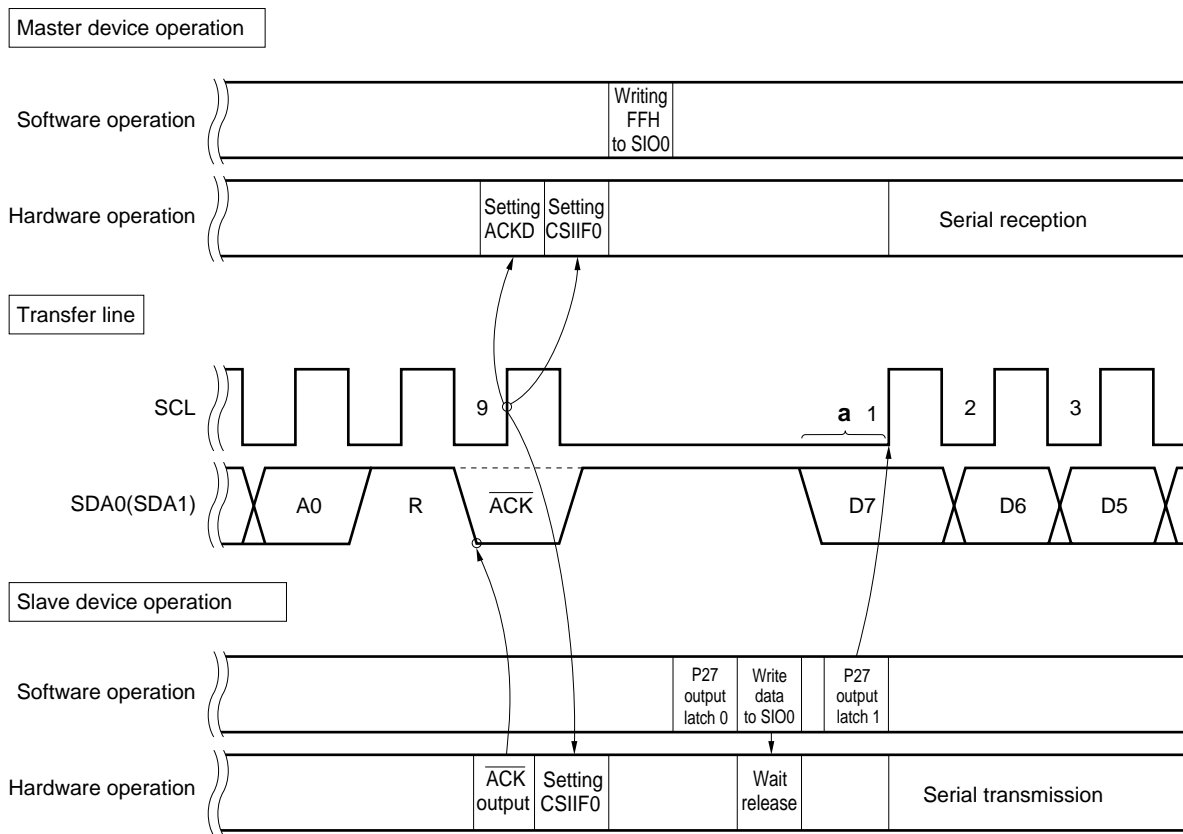
If the slave sends data, the wait is immediately released by execution of an SIO0 write instruction and the clock rises without the start transmission bit being output in the data line. Therefore, manipulate the P27 output latch through the program as shown in Figure 16-25 to transmit data correctly. At this time, control the low-level width ("a" in Figure 16-25) of the first serial clock at the timing used for setting the P27 output latch to 1 after execution of an SIO0 write instruction.

In addition, if the acknowledge signal from the master is not output (if data transmission from the slave is completed), set 1 in the WREL flag of SINT and release the wait.

For these timings, see Figure 16-23.

www.DataSheet4U.com

Figure 16-25. Slave Wait Release (Transmission)



(3) Slave wait release (slave reception)

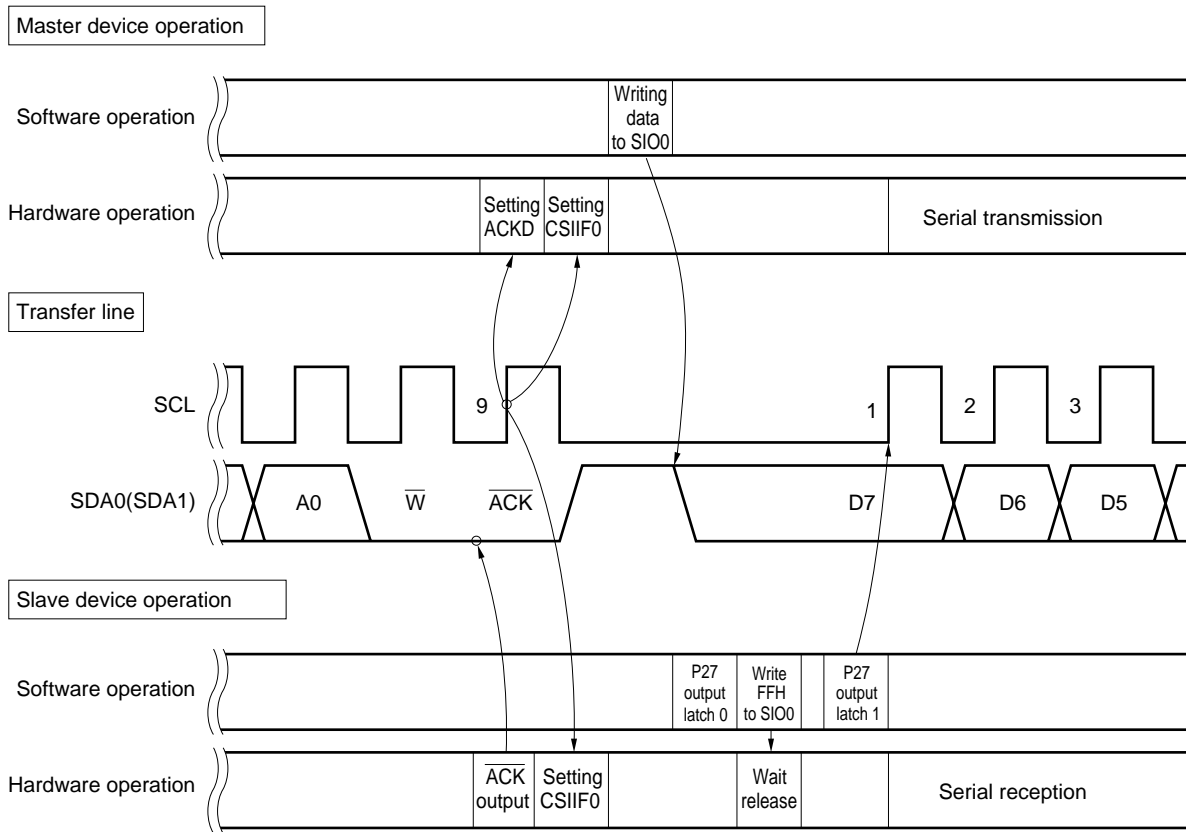
✱

The wait status of a slave is released by setting the WREL flag, which is bit 2 of the interrupt timing specify register (SINT), or by executing an SIO0 write instruction.

When a slave receives data, if the SCL line immediately enters a high-impedance state due to a write to SIO0, the slave may not receive the first bit of the data sent from the master. This is because SIO0 cannot start operation if the SCL line is in a high-impedance state during execution of a write instruction to SIO0 (until the next instruction execution is started). Therefore, manipulate the P27 output latch through the program as shown in Figure 16-26 to receive data correctly.

For these timings, see Figure 16-22.

Figure 16-26. Slave Wait Release (Reception)



(4) Reception completion of slave

During processing of reception completion by a slave device, confirm the statuses of CMDD and COI (if CMDD = 1). This procedure is necessary to use the wake-up function normally. If an uncertain amount of data is sent from the master device, the slave device cannot determine whether the start condition signal or the data will be sent from the master. This may disable use of the wake-up function.

16.4.6 $\overline{\text{SCK0/SCL/P27}}$ pin output manipulation

The $\overline{\text{SCK0/SCL/P27}}$ pin enables static output by manipulating software in addition to normal serial clock output.

The number of serial clocks can be set by software (SI0/SB0/SDA0 and SO0/SB1/SDA1 pins are controlled with the RELT and CMDT bits of serial bus interface control register (SBIC)).

The $\overline{\text{SCK0/SCL/P27}}$ pin output should be manipulated as described below.

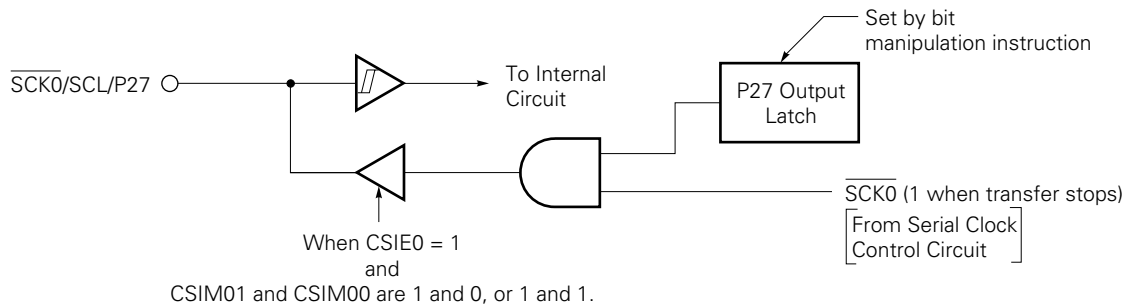
(1) In 3-wire serial I/O mode and 2-wire serial I/O mode

The $\overline{\text{SCK0/SCL/P27}}$ pin output level is manipulated by the P27 output latch.

<1> Set serial operating mode register 0 (CSIM0) ($\overline{\text{SCK0}}$ pin is set in the output mode and serial operation is enabled). While serial transfer is suspended, $\overline{\text{SCK0}}$ is set to 1.

<2> Manipulate the content of the P27 output latch by executing the bit manipulation instruction.

Figure 16-27. $\overline{\text{SCK0/SCL/P27}}$ Pin Configuration



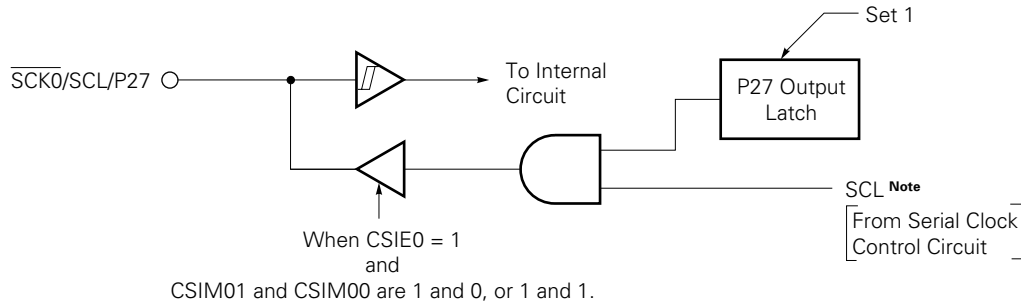
(2) In I²C bus mode

The $\overline{\text{SCK0/SCL/P27}}$ pin output level is manipulated by the CLC bit of interrupt timing specify register (SINT).

<1> Set serial operating mode register 0 (CSIM0) (SCL pin is set in the output mode and serial operation is enabled). Set 1 to the P27 output latch. While serial transfer is suspended, SCL is set to 0.

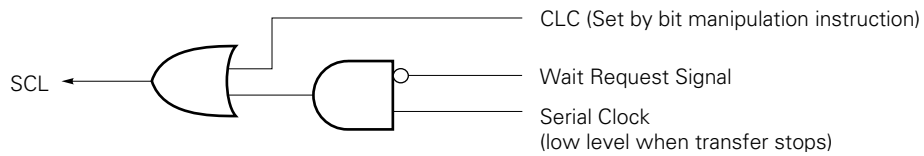
<2> Manipulate the content of the CLC bit of SINT by executing the bit manipulation instruction.

Figure 16-28. $\overline{\text{SCK0/SCL/P27}}$ Pin Configuration



Note The level of SCL signal follows the contents of logic circuit shown in Figure 16-29.

Figure 16-29. Logic Circuit of SCL Signal



- Remarks**
1. This figure shows the relationship of each signal, and does not show the internal circuit.
 2. CLC : Bit 3 of interrupt timing specify register (SINT)

[MEMO]

www.DataSheet4U.com

CHAPTER 17 SERIAL INTERFACE CHANNEL 2

17.1 Serial Interface Channel 2 Functions

Serial interface channel 2 has the following three modes.

- Operation stop mode
- Asynchronous serial interface (UART) mode
- 3-wire serial I/O mode

(1) Operation stop mode

This mode is used when serial transfer is not carried out to reduce power consumption.

(2) Asynchronous serial interface (UART) mode

In this mode, one byte of data is transmitted/received following the start bit, and full-duplex operation is possible.

A dedicated UART baud rate generator is incorporated, allowing communication over a wide range of baud rates. In addition, the baud rate can be defined by scaling the input clock to the ASCK pin.

The MIDI standard baud rate (31.25 kbps) can be used by employing the dedicated UART baud rate generator.

(3) 3-wire serial I/O mode (MSB-first/LSB-first switchable)

In this mode, 8-bit data transfer is performed using three lines: the serial clock ($\overline{\text{SCK2}}$), and serial data lines (SI2, SO2).

In the 3-wire serial I/O mode, simultaneous transmission and reception is possible, increasing the data transfer processing speed.

Either the MSB or LSB can be specified as the start bit for an 8-bit data serial transfer, allowing connection to devices using either as the start bit.

The 3-wire serial I/O mode is useful for connection to peripheral I/Os and display controllers, etc., which incorporate a conventional synchronous clocked serial interface, such as the 75X series, 78K series, 17K series, etc.

17.2 Serial Interface Channel 2 Configuration

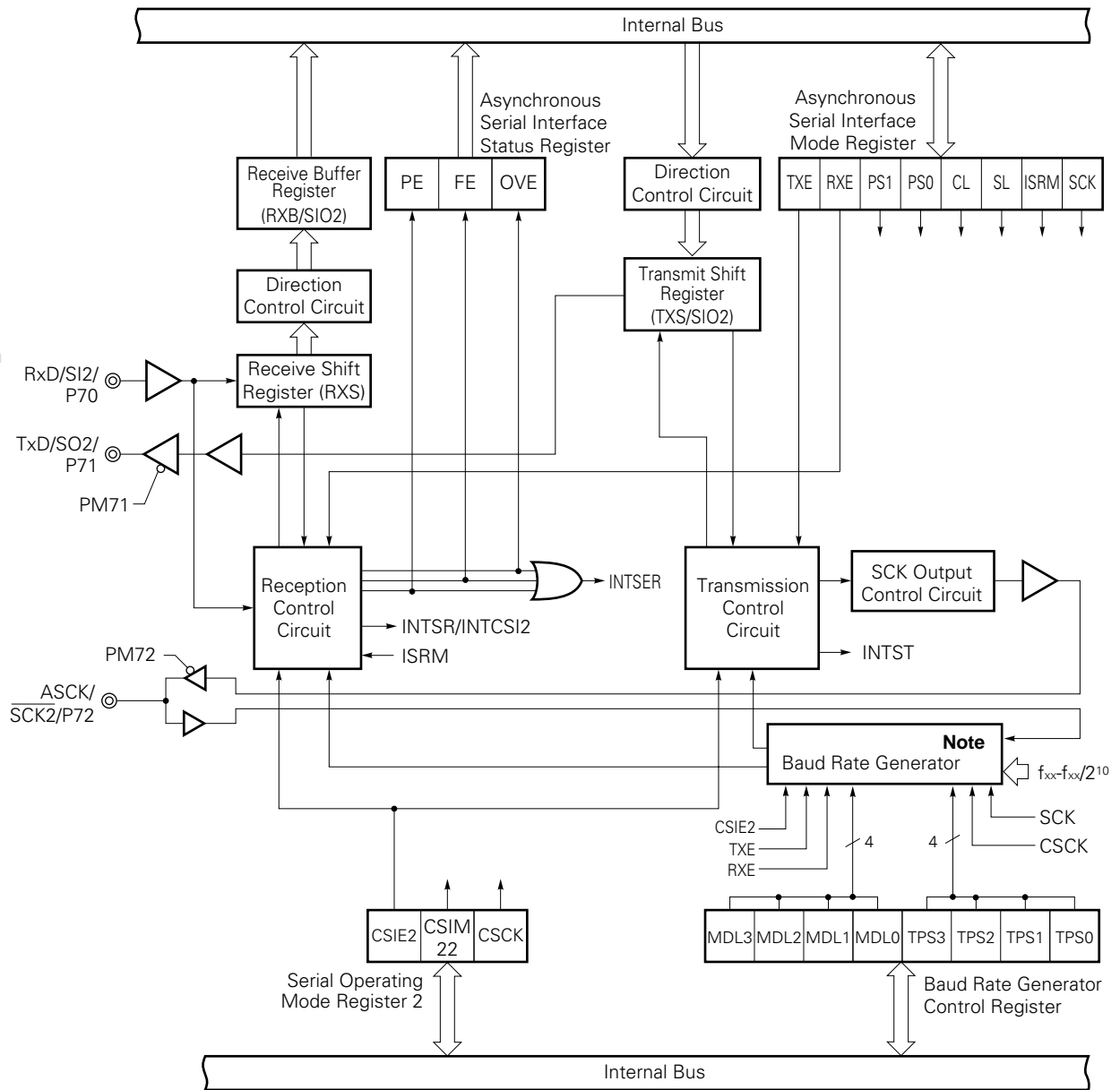
Serial interface channel 2 consists of the following hardware.

Table 17-1. Serial Interface Channel 2 Configuration

Item	Configuration
Register	Transmit shift register (TXS) Receive shift register (RXS) Receive buffer register (RXB)
Control register	Serial operating mode register 2 (CSIM2) Asynchronous serial interface mode register (ASIM) Asynchronous serial interface status register (ASIS) Baud rate generator control register (BRGC)

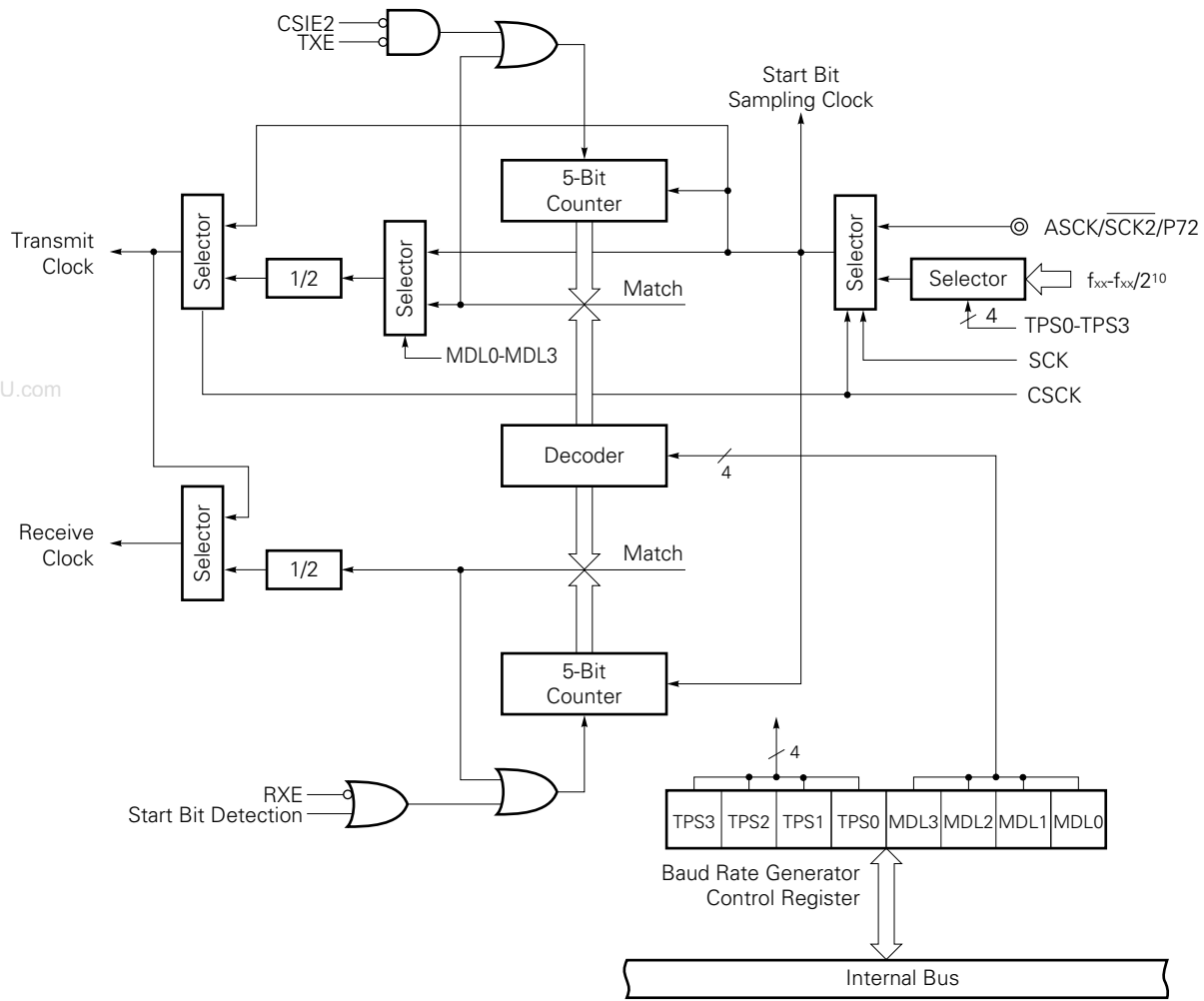
Figure 17-1. Serial Interface Channel 2 Block Diagram

*



Note See Figure 17-2 for the baud rate generator configuration.

Figure 17-2. Baud Rate Generator Block Diagram



www.DataSheet4U.com

(1) Transmit shift register (TXS)

This register is used to set the transmit data. The data written in TXS is transmitted as serial data. If the data length is specified as 7 bits, bits 0 to 6 of the data written in TXS are transferred as transmit data. Writing data to TXS starts the transmit operation. TXS is written to with an 8-bit memory manipulation instruction. It cannot be read. TXS value is FFH after $\overline{\text{RESET}}$ input.

Caution TXS must not be written to during a transmit operation. TXS and the receive buffer register (RXB) are allocated to the same address, and when a read is performed, the value of RXB is read.

(2) Receive shift register (RXS)

This register is used to convert serial data input to the RxD pin to parallel data. When one byte of data is received, the receive data is transferred to the receive buffer register (RXB). RXS cannot be directly manipulated by a program.

(3) Receive buffer register (RXB)

This register holds receive data. Each time one byte of data is received, new receive data is transferred from the receive shift register (RXS). If the data length is specified as 7 bits, the receive data is transferred to bits 0 to 6 of RXB, and the MSB of RXB is always set to 0. RXB is read with an 8-bit memory manipulation instruction. It cannot be written to. RXB value is FFH after $\overline{\text{RESET}}$ input.

Caution RXB and the transmit shift register (TXS) are allocated to the same address, and when a write is performed, the value is written to TXS.

(4) Transmission control circuit

This circuit performs transmit operation control such as the addition of a start bit, parity bit and stop bit to data written in the transmit shift register (TXS) in accordance with the contents set in the asynchronous serial interface mode register (ASIM).

(5) Reception control circuit

This circuit controls receive operations in accordance with the contents set in the asynchronous serial interface mode register (ASIM). It performs error checks for parity errors, etc., during a receive operation, and if an error is detected, sets a value in the asynchronous serial interface status register (ASIS) in accordance with the error contents.

17.3 Serial Interface Channel 2 Control Registers

Serial interface channel 2 is controlled by the following four registers.

- Serial Operating Mode Register 2 (CSIM2)
- Asynchronous Serial Interface Mode Register (ASIM)
- Asynchronous Serial Interface Status Register (ASIS)
- Baud Rate Generator Control Register (BRGC)

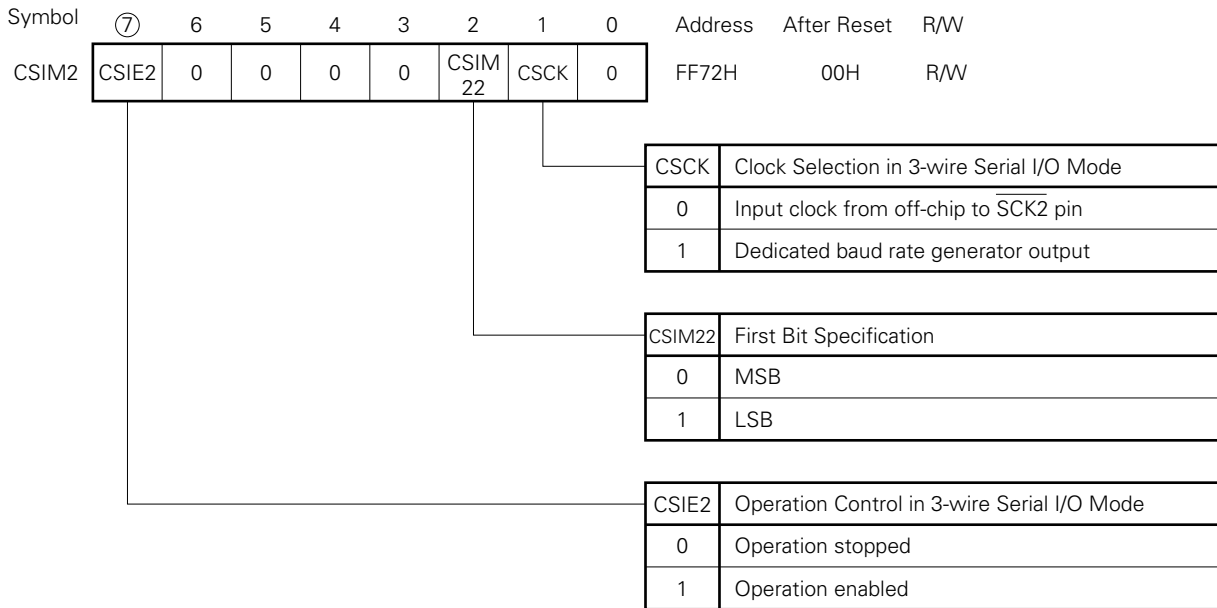
(1) Serial operating mode register 2 (CSIM2)

This register is set when serial interface channel 2 is used in the 3-wire serial I/O mode.

CSIM2 is set with a 1-bit or 8-bit memory manipulation instruction.

www.DataSheet4U.com $\overline{\text{RESET}}$ input sets CSIM2 to 00H.

Figure 17-3. Serial Operating Mode Register 2 Format

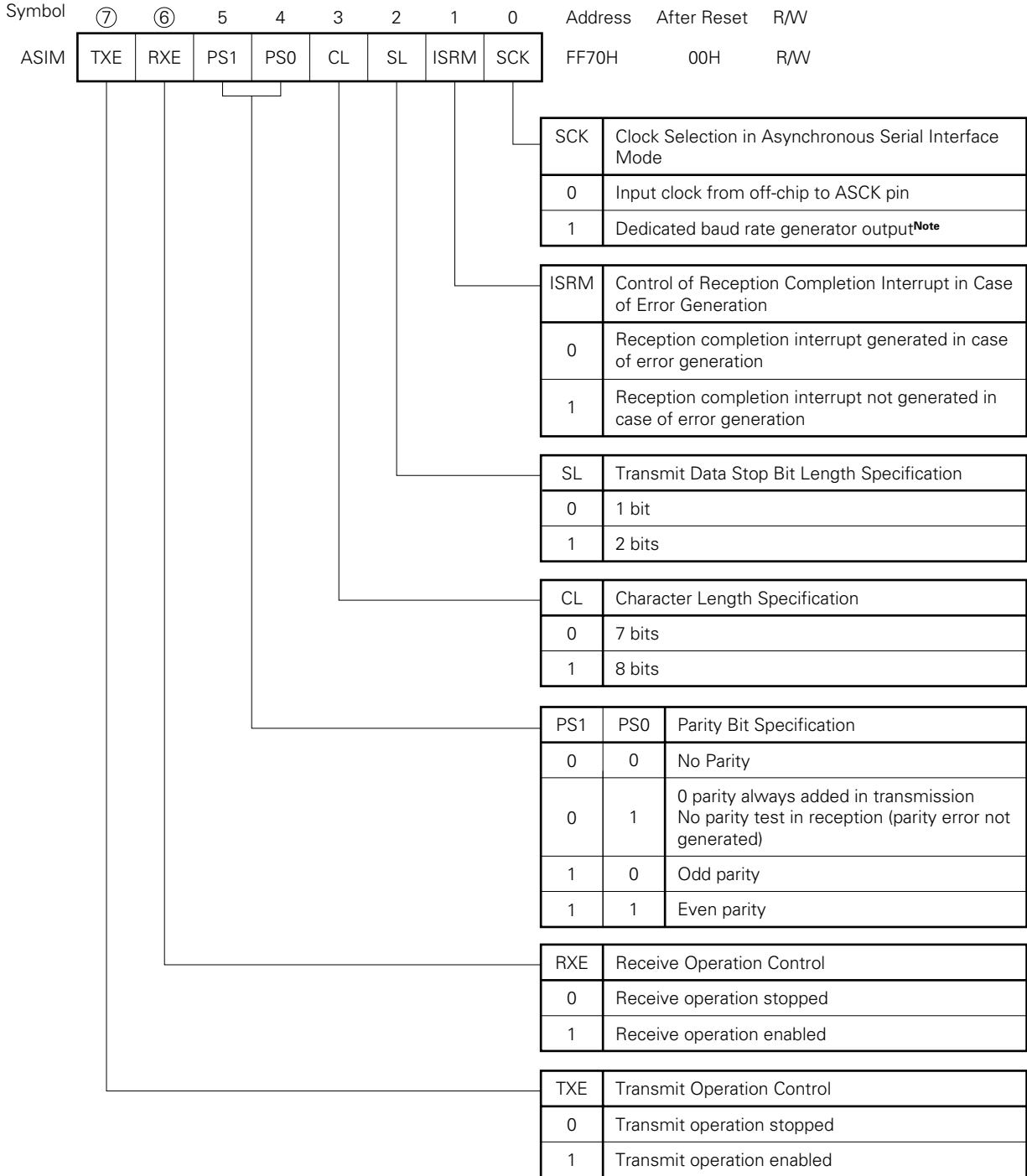


- Cautions**
1. Ensure that bit 0 and bit 3 to bit 6 are set to 0.
 2. When UART mode is selected, CSIM2 should be set to 00H.

(2) Asynchronous serial interface mode register (ASIM)

This register is set when serial interface channel 2 is used in the asynchronous serial interface mode. ASIM is set with a 1-bit or 8-bit memory manipulation instruction. $\overline{\text{RESET}}$ input sets ASIM to 00H.

Figure 17-4. Asynchronous Serial Interface Mode Register Format



Note When SCK is set to 1 and the baud rate generator output is selected, the ASCK pin can be used as an input/output port.

- Cautions**
1. When the 3-wire serial I/O mode is selected, 00H should be set in ASIM.
 2. The serial transmit/receive operation must be stopped before changing the operating mode.

Table 17-2. Serial Interface Channel 2 Operating Mode Settings

(1) Operation Stop Mode

ASIM			CSIM2			PM70	P70	PM71	P71	PM72	P72	Start Bit	Shift Clock	P70/SI2 /RxD Pin Functions	P71/SO2 /TxD Pin Functions	P72/SCK2 /ASCK Pin Functions
TXE	RXE	SCK	CSIE2	CSIM22	CSCK											
0	0	x	0	x	x	x ^{Note1}	x ^{Note1}	x ^{Note1}	x ^{Note1}	x ^{Note1}	x ^{Note1}	—	—	P70	P71	P72
Other than above												Setting prohibited				

(2) 3-wire Serial I/O Mode

ASIM			CSIM2			PM70	P70	PM71	P71	PM72	P72	Start Bit	Shift Clock	P70/SI2 /RxD Pin Functions	P71/SO2 /TxD Pin Functions	P72/SCK2 /ASCK Pin Functions			
TXE	RXE	SCK	CSIE2	CSIM22	CSCK														
0	0	0	1	0	0	1 ^{Note2}	x ^{Note2}	0	1	1	x	MSB	External clock	SI2 ^{Note2}	SO2 (CMOS output)	SCK2 input			
																0	1	SCK2 output	
			1	1	0					1	x		LSB			External clock	SI2 ^{Note2}	SO2 (CMOS output)	SCK2 input
																			0
Other than above												Setting prohibited							

(3) Asynchronous Serial Interface Mode

ASIM			CSIM2			PM70	P70	PM71	P71	PM72	P72	Start Bit	Shift Clock	P70/SI2 /RxD Pin Functions	P71/SO2 /TxD Pin Functions	P72/SCK2 /ASCK Pin Functions
TXE	RXE	SCK	CSIE2	CSIM22	CSCK											
1	0	0	0	0	0	x ^{Note1}	x ^{Note1}	0	1	1	x	LSB	External clock	P70	TxD (CMOS output)	ASCK input
		1											x ^{Note1}			x ^{Note1}
0	1	0	0	0	0	1	x	x ^{Note1}	x ^{Note1}	1	x		External clock	RxD	P71	ASCK input
		1											x ^{Note1}			
1	1	0	0	0	0	1	x	0	1	1	x	External clock	TxD (CMOS output)	ASCK input		
		1										x ^{Note1}			x ^{Note1}	Internal clock
Other than above												Setting prohibited				

- Notes**
1. Can be used freely as port function.
 2. Can be used as P70 (CMOS input/output) when only transmitter is used.

Remark x: Don't care

(3) Asynchronous serial interface status register (ASIS)

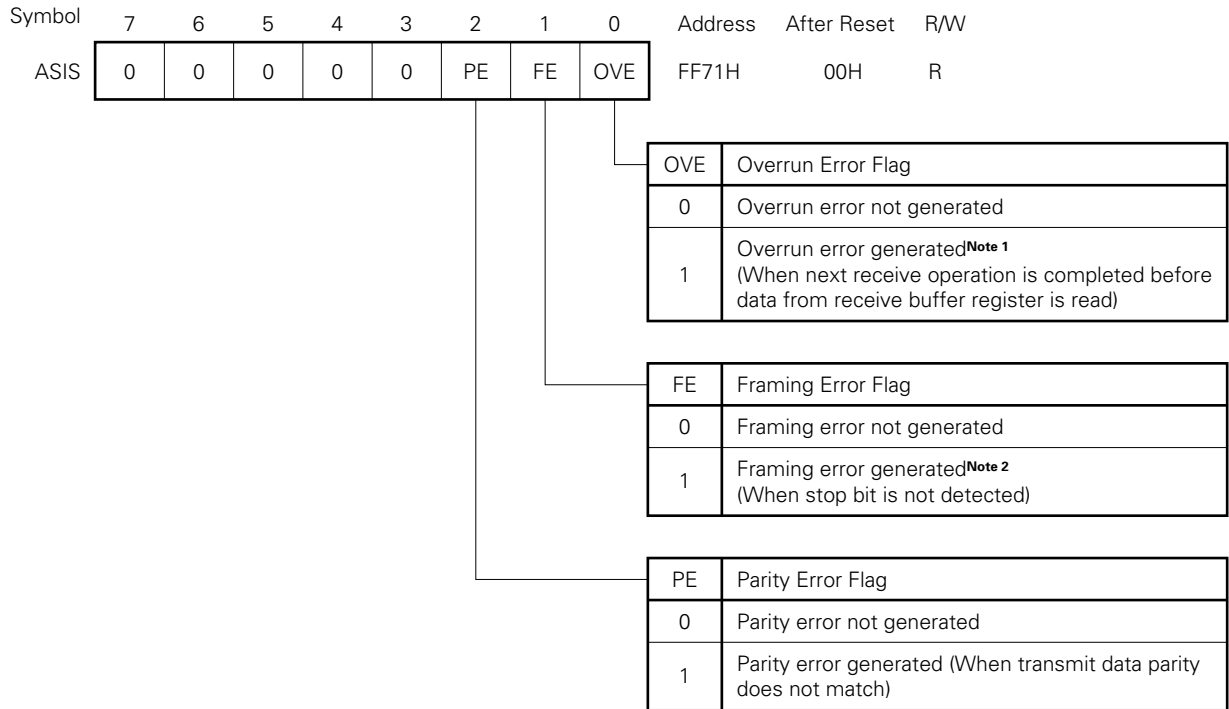
This is a register which displays the type of error when a reception error is generated in the asynchronous serial interface mode.

ASIS is read with a 1-bit or 8-bit memory manipulation instruction.

In 3-wire serial I/O mode, the contents of the ASIS are undefined.

RESET input sets ASIS to 00H.

Figure 17-5. Asynchronous Serial Interface Status Register Format



- Notes**
- The receive buffer register (RXB) must be read when an overrun error is generated. Overrun errors will continue to be generated until RXB is read.
 - Even if the stop bit length has been set as 2 bits by bit 2 (SL) of the asynchronous serial interface mode register, only single stop bit detection is performed during reception.

(4) Baud rate generator control register (BRGC)

This register sets the serial clock for serial interface channel 2.

BRGC is set with an 8-bit memory manipulation instruction.

$\overline{\text{RESET}}$ input sets BRGC to 00H.

Figure 17-6. Baud Rate Generator Control Register Format (1/2)

Symbol	7	6	5	4	3	2	1	0	Address	After Reset	R/W
BRGC	TPS3	TPS2	TPS1	TPS0	MDL3	MDL2	MDL1	MDL0	FF73H	00H	R/W

MDL3	MDL2	MDL1	MDL0	Baud Rate Generator Input Clock Selection	k
0	0	0	0	f _{sck} /16	0
0	0	0	1	f _{sck} /17	1
0	0	1	0	f _{sck} /18	2
0	0	1	1	f _{sck} /19	3
0	1	0	0	f _{sck} /20	4
0	1	0	1	f _{sck} /21	5
0	1	1	0	f _{sck} /22	6
0	1	1	1	f _{sck} /23	7
1	0	0	0	f _{sck} /24	8
1	0	0	1	f _{sck} /25	9
1	0	1	0	f _{sck} /26	10
1	0	1	1	f _{sck} /27	11
1	1	0	0	f _{sck} /28	12
1	1	0	1	f _{sck} /29	13
1	1	1	0	f _{sck} /30	14
1	1	1	1	f _{sck} ^{Note}	—

Note Can only be used in 3-wire serial I/O mode.

Remarks 1. f_{sck} : 5-bit counter source clock

2. k : Value set in MDL0 to MDL3 (0 ≤ k ≤ 14)

Figure 17-6. Baud Rate Generator Control Register Format (2/2)

TPS3	TPS2	TPS1	TPS0	5-Bit Counter Source Clock Selection				n	
				MCS=1		MCS=0			
0	0	0	0	$f_{xx}/2^{10}$	$f_{xx}/2^{10}$	(4.9 kHz)	$f_x/2^{11}$	(2.4 kHz)	11
0	1	0	1	f_{xx}	f_x	(5.0 MHz)	$f_x/2$	(2.5 MHz)	1
0	1	1	0	$f_{xx}/2$	$f_x/2$	(2.5 MHz)	$f_x/2^2$	(1.25 MHz)	2
0	1	1	1	$f_{xx}/2^2$	$f_x/2^2$	(1.25 MHz)	$f_x/2^3$	(625 kHz)	3
1	0	0	0	$f_{xx}/2^3$	$f_x/2^3$	(625 kHz)	$f_x/2^4$	(313 kHz)	4
1	0	0	1	$f_{xx}/2^4$	$f_x/2^4$	(313 kHz)	$f_x/2^5$	(156 kHz)	5
1	0	1	0	$f_{xx}/2^5$	$f_x/2^5$	(156 kHz)	$f_x/2^6$	(78.1 kHz)	6
1	0	1	1	$f_{xx}/2^6$	$f_x/2^6$	(78.1 kHz)	$f_x/2^7$	(39.1 kHz)	7
1	1	0	0	$f_{xx}/2^7$	$f_x/2^7$	(39.1 kHz)	$f_x/2^8$	(19.5 kHz)	8
1	1	0	1	$f_{xx}/2^8$	$f_x/2^8$	(19.5 kHz)	$f_x/2^9$	(9.8 kHz)	9
1	1	1	0	$f_{xx}/2^9$	$f_x/2^9$	(9.8 kHz)	$f_x/2^{10}$	(4.9 kHz)	10
Other than above				Setting prohibited					

Caution When a write is performed to BRGC during a communication operation, baud rate generator output is disrupted and communication cannot be performed normally. Therefore, BRGC must not be written to during a communication operation.

- Remarks**
1. f_x : Main system clock oscillation frequency
 2. f_{xx} : Main system clock frequency (f_x or $f_x/2$)
 3. MCS : Oscillation mode selection register bit 0
 4. n : Value set in TPS0 to TPS3 ($1 \leq n \leq 11$)
 5. Figures in parentheses apply to operation with $f_x=5.0$ MHz

The baud rate transmit/receive clock generated is either a signal scaled from the main system clock, or a signal scaled from the clock input from the ASCK pin.

(a) Generation of baud rate transmit/receive clock by means of main system clock

The transmit/receive clocks generated by scaling the main system clock. The baud rate generated from the main system clock is found from the following expression.

$$[\text{Baud rate}] = \frac{f_{xx}}{2^n \times (k+16)} \text{ [Hz]}$$

- f_x : Main system clock oscillation frequency
- f_{xx} : Main system clock frequency (f_x or $f_x/2$)
- n : Value set in TPS0 to TPS3 ($1 \leq n \leq 11$)
- k : Value set in MDL0 to MDL3 ($0 \leq k \leq 14$)

www.DataSheet4U.com

Table 17-3. Relation between Main System Clock and Baud Rate

Baud Rate (bps)	$f_x=5.0$ MHz				$f_x=4.19$ MHz			
	MCS=1		MCS=0		MCS=1		MCS=0	
	BRGC Set Value	Error (%)	BRGC Set Value	Error (%)	BRGC Set Value	Error (%)	BRGC Set Value	Error (%)
75	-		00H	1.73	0BH	1.14	EBH	1.14
110	06H	0.88	E6H	0.88	03H	-2.01	E3H	-2.01
150	00H	1.73	E0H	1.73	EBH	1.14	DBH	1.14
300	E0H	1.73	D0H	1.73	DBH	1.14	CBH	1.14
600	D0H	1.73	C0H	1.73	CBH	1.14	BBH	1.14
1200	C0H	1.73	B0H	1.73	BBH	1.14	ABH	1.14
2400	B0H	1.73	A0H	1.73	ABH	1.14	9BH	1.14
4800	A0H	1.73	90H	1.73	9BH	1.14	8BH	1.14
9600	90H	1.73	80H	1.73	8BH	1.14	7BH	1.14
19200	80H	1.73	70H	1.73	7BH	1.14	6BH	1.14
31250	74H	0	64H	0	71H	-1.31	61H	-1.31
38400	70H	1.73	60H	1.73	6BH	1.14	5BH	1.14
* 76800	60H	1.73	50H	1.73	5BH	1.14	—	—

Remark MCS: Oscillation mode selection register bit 0

(b) Generation of baud rate transmit/receive clock by means of external clock from ASCK pin

The transmit/receive clock is generated by scaling the clock input from the ASCK pin. The baud rate generated from the clock input from the ASCK pin is obtained with the following expression.

$$[\text{Baud rate}] = \frac{f_{\text{ASCK}}}{2 \times (k+16)} \text{ [Hz]}$$

f_{ASCK} : Frequency of clock input to ASCK pin

k : Value set in MDL0 to MDL3 ($0 \leq k \leq 14$)

Table 17-4. Relation between ASCK Pin Input Frequency and Baud Rate (When BRGC is set to 00H)

Baud Rate (bps)	ASCK Pin Input Frequency
75	2.4 kHz
110	3.52 kHz
150	4.8 kHz
300	9.6 kHz
600	19.2 kHz
1200	38.4 kHz
2400	76.8 kHz
4800	153.6 kHz
9600	307.2 kHz
19200	614.4 kHz
31250	1000.0 kHz
38400	1228.8 kHz

17.4 Serial Interface Channel 2 Operation

Serial interface channel 2 has the following three modes.

- Operation stop mode
- Asynchronous serial interface (UART) mode
- 3-wire serial I/O mode

17.4.1 Operation stop mode

In the operation stop mode, serial transfer is not performed, and therefore power consumption can be reduced.

In the operation stop mode, the P70/SI2/RxD, P71/SO2/TxD and P72/ $\overline{\text{SCK2}}$ /ASCK pins can be used as normal input/output ports.

www.DataSheet4U.com

(1) Register setting

Operation stop mode settings are performed using serial operating mode register 2 (CSIM2) and the asynchronous serial interface mode register (ASIM).

(a) Serial operating mode register 2 (CSIM2)

CSIM2 is set with a 1-bit or 8-bit memory manipulation instruction.

$\overline{\text{RESET}}$ input sets CSIM2 to 00H.

The bit used in the operation stop mode is indicated by shading.

Symbol	⑦	6	5	4	3	2	1	0	Address	After Reset	R/W
CSIM2	CSIE2	0	0	0	0	CSIM 22	CSCK	0	FF72H	00H	R/W

CSIE2	Operation Control in 3-wire Serial I/O Mode
0	Operation stopped
1	Operation enabled

Caution Ensure that bit 0 and bit 3 to bit 6 are set to 0.

(b) Asynchronous serial interface mode register (ASIM)

ASIM is set with a 1-bit or 8-bit memory manipulation instruction.

$\overline{\text{RESET}}$ input sets ASIM to 00H.

The bits used in the operation stop mode are indicated by shading.

Symbol	⑦	⑥	5	4	3	2	1	0	Address	After Reset	R/W
ASIM	TXE	RXE	PS1	PS0	CL	SL	ISRM	SCK	FF70H	00H	R/W

RXE	Receive Operation Control
0	Receive operation stopped
1	Receive operation enabled

TXE	Transmit Operation Control
0	Transmit operation stopped
1	Transmit operation enabled

www.DataSheet4U.com

17.4.2 Asynchronous serial interface (UART) mode

In this mode, one byte of data is transmitted/received following the start bit, and full-duplex operation is possible. A dedicated UART baud rate generator is incorporated, allowing communication over a wide range of baud rates. In addition, the baud rate can be defined by scaling the input clock to the ASCK pin.

The MIDI standard baud rate (31.25 kbps) can be used by employing the dedicated UART baud rate generator.

(1) Register setting

UART mode settings are performed using serial operating mode register 2 (CSIM2), the asynchronous serial interface mode register (ASIM), the asynchronous serial interface status register (ASIS), and the baud rate generator control register (BRGC).

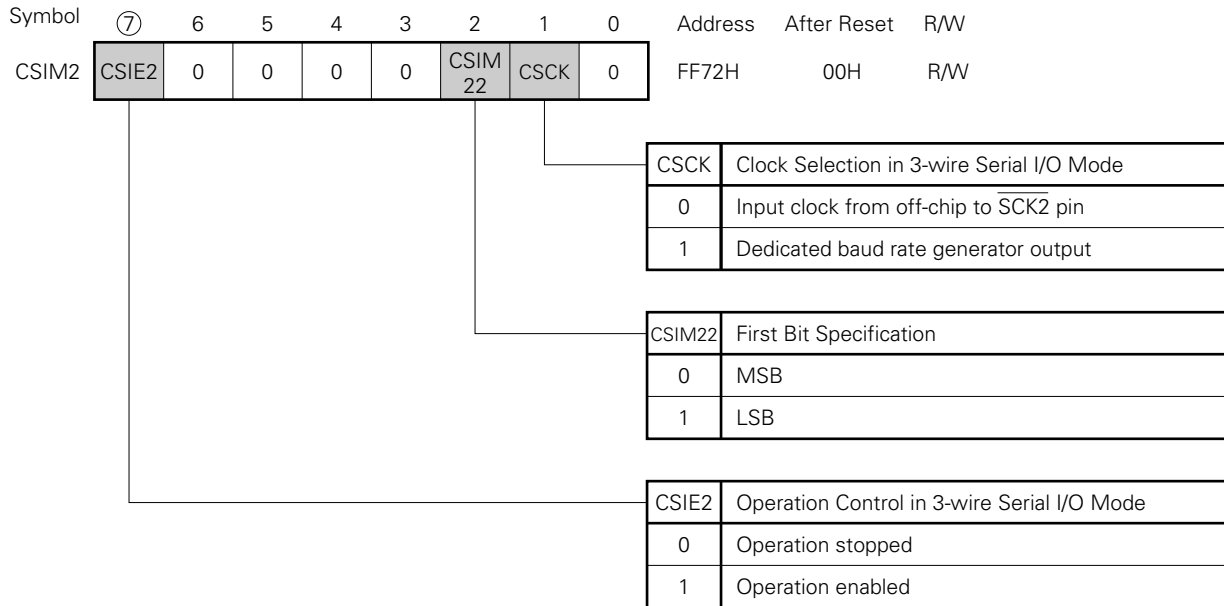
(a) Serial operating mode register 2 (CSIM2)

CSIM2 is set with a 1-bit or 8-bit memory manipulation instruction.

RESET input sets CSIM2 to 00H.

The bits used in the UART mode are indicated by shading.

When the UART mode is selected, 00H should be set in CSIM2.



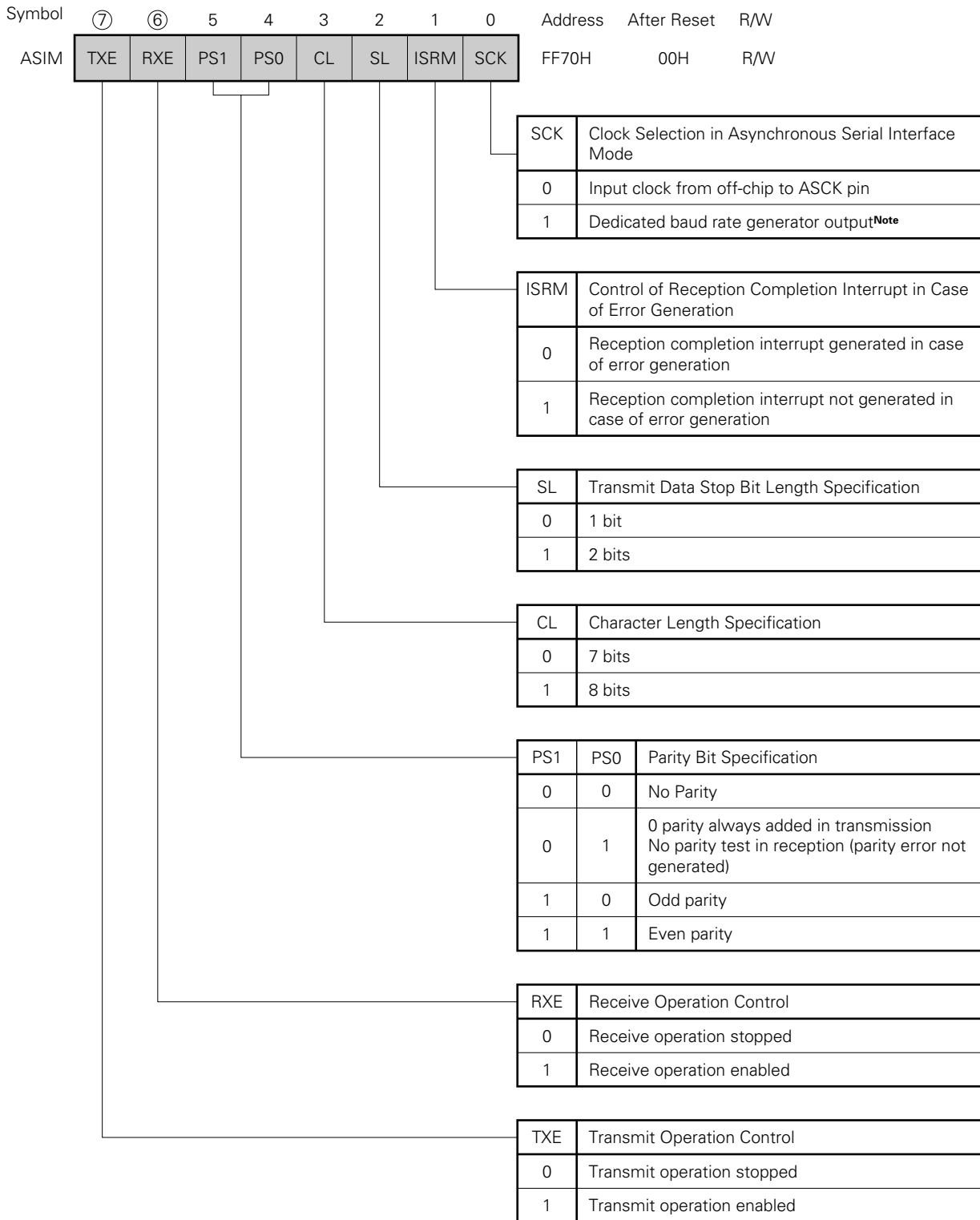
Caution Ensure that bit 0 and bit 3 to bit 6 are set to 0.

(b) Asynchronous serial interface mode register (ASIM)

ASIM is set with a 1-bit or 8-bit memory manipulation instruction.

RESET input sets ASIM to 00H.

The bits used in the UART mode are indicated by shading.



Note When SCK is set to 1 and the baud rate generator output is selected, the ASCK pin can be used as an input/output port.

Caution The serial transmit/receive operation must be stopped before changing the operating mode.

(c) Asynchronous serial interface status register (ASIS)

ASIS is set with a 1-bit or 8-bit memory manipulation instruction.

$\overline{\text{RESET}}$ input sets ASIS to 00H.

The bits used in the UART mode are indicated by shading.

Symbol	7	6	5	4	3	2	1	0	Address	After Reset	R/W
ASIS	0	0	0	0	0	PE	FE	OVE	FF71H	00H	R

www.DataSheet4U.com

OVE	Overrun Error Flag
0	Overrun error not generated
1	Overrun error generated ^{Note 1} (When next receive operation is completed before data from receive buffer register is read)

FE	Framing Error Flag
0	Framing error not generated
1	Framing error generated ^{Note 2} (When stop bit is not detected)

PE	Parity Error Flag
0	Parity error not generated
1	Parity error generated (When transmit data parity does not match)

Notes 1. The receive buffer register (RXB) must be read when an overrun error is generated. Overrun errors will continue to be generated until RXB is read.

2. Even if the stop bit length has been set as 2 bits by bit 2 (SL) of the asynchronous serial interface mode register, only single stop bit detection is performed during reception.

(d) Baud rate generator control register (BRGC)

BRGC is set with an 8-bit memory manipulation instruction.

$\overline{\text{RESET}}$ input sets BRGC to 00H.

The bits used in the UART mode are indicated by shading.

Symbol	7	6	5	4	3	2	1	0	Address	After Reset	R/W
BRGC	TPS3	TPS2	TPS1	TPS0	MDL3	MDL2	MDL1	MDL0	FF73H	00H	R/W

MDL3	MDL2	MDL1	MDL0	Baud Rate Generator Input Clock Selection	k
0	0	0	0	f _{sck} /16	0
0	0	0	1	f _{sck} /17	1
0	0	1	0	f _{sck} /18	2
0	0	1	1	f _{sck} /19	3
0	1	0	0	f _{sck} /20	4
0	1	0	1	f _{sck} /21	5
0	1	1	0	f _{sck} /22	6
0	1	1	1	f _{sck} /23	7
1	0	0	0	f _{sck} /24	8
1	0	0	1	f _{sck} /25	9
1	0	1	0	f _{sck} /26	10
1	0	1	1	f _{sck} /27	11
1	1	0	0	f _{sck} /28	12
1	1	0	1	f _{sck} /29	13
1	1	1	0	f _{sck} /30	14

(continued)

Remark f_{sck} : 5-bit counter source clock
 k : Value set in MDL0 to MDL3 (0 ≤ k ≤ 14)

TPS3	TPS2	TPS1	TPS0	5-Bit Counter Source Clock Selection				n
				MCS=1		MCS=0		
0	0	0	0	$f_{xx}/2^{10}$	$f_x/2^{10}$ (4.9 kHz)	$f_x/2^{11}$ (2.4 kHz)		11
0	1	0	1	f_{xx}	f_x (5.0 MHz)	$f_x/2$ (2.5 MHz)		1
0	1	1	0	$f_{xx}/2$	$f_x/2$ (2.5 MHz)	$f_x/2^2$ (1.25 MHz)		2
0	1	1	1	$f_{xx}/2^2$	$f_x/2^2$ (1.25 MHz)	$f_x/2^3$ (625 kHz)		3
1	0	0	0	$f_{xx}/2^3$	$f_x/2^3$ (625 kHz)	$f_x/2^4$ (313 kHz)		4
1	0	0	1	$f_{xx}/2^4$	$f_x/2^4$ (313 kHz)	$f_x/2^5$ (156 kHz)		5
1	0	1	0	$f_{xx}/2^5$	$f_x/2^5$ (156 kHz)	$f_x/2^6$ (78.1 kHz)		6
1	0	1	1	$f_{xx}/2^6$	$f_x/2^6$ (78.1 kHz)	$f_x/2^7$ (39.1 kHz)		7
1	1	0	0	$f_{xx}/2^7$	$f_x/2^7$ (39.1 kHz)	$f_x/2^8$ (19.5 kHz)		8
1	1	0	1	$f_{xx}/2^8$	$f_x/2^8$ (19.5 kHz)	$f_x/2^9$ (9.8 kHz)		9
1	1	1	0	$f_{xx}/2^9$	$f_x/2^9$ (9.8 kHz)	$f_x/2^{10}$ (4.9 kHz)		10
Other than above				Setting prohibited				

Caution When a write is performed to BRGC during a communication operation, baud rate generator output is disrupted and communication cannot be performed normally. Therefore, BRGC must not be written to during a communication operation.

- Remarks**
1. f_x : Main system clock oscillation frequency
 2. f_{xx} : Main system clock frequency (f_x or $f_x/2$)
 3. MCS : Oscillation mode selection register bit 0
 4. n : Value set in TPS0 to TPS3 ($1 \leq n \leq 11$)
 5. Figures in parentheses apply to operation with $f_x = 5.0$ MHz.

The baud rate transmit/receive clock generated is either a signal scaled from the main system clock, or a signal scaled from the clock input from the ASCK pin.

(i) Generation of baud rate transmit/receive clock by means of main system clock

The transmit/receive clock is generated by scaling the main system clock. The baud rate generated from the main system clock is obtained with the following expression.

$$[\text{Baud rate}] = \frac{f_{xx}}{2^n \times (k+16)} \text{ [Hz]}$$

- fx : Main system clock oscillation frequency
- fxx : Main system clock frequency (fx or fx/2)
- n : Value set in TPS0 to TPS3 (1 ≤ n ≤ 11)
- k : Value set in MDL0 to MDL3 (0 ≤ k ≤ 14)

www.DataSheet4U.com

Table 17-5. Relation between Main System Clock and Baud Rate

Baud Rate (bps)	fx=5.0 MHz				fx=4.19 MHz			
	MCS=1		MCS=0		MCS=1		MCS=0	
	BRGC Set Value	Error (%)	BRGC Set Value	Error (%)	BRGC Set Value	Error (%)	BRGC Set Value	Error (%)
75	-		00H	1.73	0BH	1.14	EBH	1.14
110	06H	0.88	E6H	0.88	03H	-2.01	E3H	-2.01
150	00H	1.73	E0H	1.73	EBH	1.14	DBH	1.14
300	E0H	1.73	D0H	1.73	DBH	1.14	CBH	1.14
600	D0H	1.73	C0H	1.73	CBH	1.14	BBH	1.14
1200	C0H	1.73	B0H	1.73	BBH	1.14	ABH	1.14
2400	B0H	1.73	A0H	1.73	ABH	1.14	9BH	1.14
4800	A0H	1.73	90H	1.73	9BH	1.14	8BH	1.14
9600	90H	1.73	80H	1.73	8BH	1.14	7BH	1.14
19200	80H	1.73	70H	1.73	7BH	1.14	6BH	1.14
31250	74H	0	64H	0	71H	-1.31	61H	-1.31
38400	70H	1.73	60H	1.73	6BH	1.14	5BH	1.14
76800	60H	1.73	50H	1.73	5BH	1.14	—	—

*

Remark MCS: Oscillation mode selection register bit 0

(ii) Generation of baud rate transmit/receive clock by means of external clock from ASCK pin

The transmit/receive clock is generated by scaling the clock input from the ASCK pin. The baud rate generated from the clock input from the ASCK pin is obtained with the following expression.

$$[\text{Baud rate}] = \frac{f_{\text{ASCK}}}{2 \times (k+16)} \text{ [Hz]}$$

f_{ASCK} : Frequency of clock input to ASCK pin

k : Value set in MDL0 to MDL3 ($0 \leq k \leq 14$)

Table 17-6. Relation between ASCK Pin Input Frequency and Baud Rate (When BRGC is set to 00H)

Baud Rate (bps)	ASCK Pin Input Frequency
75	2.4 kHz
110	3.52 kHz
150	4.8 kHz
300	9.6 kHz
600	19.2 kHz
1200	38.4 kHz
2400	76.8 kHz
4800	153.6 kHz
9600	307.2 kHz
19200	614.4 kHz
31250	1000.0 kHz
38400	1228.8 kHz

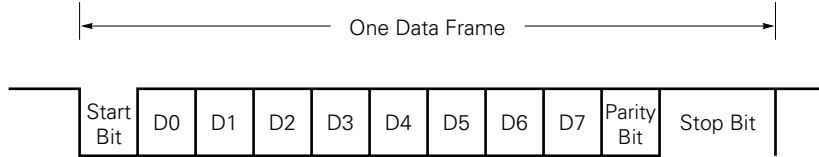
(2) Communication operation

(a) Data format

The transmit/receive data format is as shown in Figure 17-7. One data frame consists of a start bit, character bits, parity bit and stop bit(s).

The specification of character bit length, parity selection, and specification of stop bit length for each data frame is carried out with asynchronous serial interface mode register (ASIM).

Figure 17-7. Asynchronous Serial Interface Transmit/Receive Data Format



- Start bits 1 bit
- Character bits 7 bits/8 bits
- Parity bits Even parity/odd parity/0 parity/no parity
- Stop bit(s) 1 bit/2 bits

When 7 bits are selected as the number of character bits, only the lower 7 bits (bits 0 to 6) are valid; in transmission the most significant bit (bit 7) is ignored, and in reception the most significant bit (bit 7) is always "0".

The serial transfer rate is selected by means of the asynchronous serial interface mode register and the baud rate generator control register. *

If a serial data receive error is generated, the receive error contents can be determined by reading the status of the asynchronous serial interface status register (ASIS).

(b) Parity types and operation

The parity bit is used to detect a bit error in the communication data. Normally, the same kind of parity bit is used on the transmitting side and the receiving side. With even parity and odd parity, a one-bit (odd number) error can be detected. With 0 parity and no parity, an error cannot be detected.

(i) Even parity**• At transmission**

Control is executed so that the number of bits with a value of "1" contained in the transmit data including parity bit is an even number. The parity bit value should be as follows.

The number of bits with a value of "1" is an odd number in transmit data : 1

The number of bits with a value of "1" is an even number in transmit data : 0

• At reception

The number of bits with a value of "1" contained in the receive data including parity bit are counted, and if this is an odd number, a parity error is generated.

(ii) Odd parity**• At transmission**

Conversely to the situation with even parity, control is executed so that the number of bits with a value of "1" contained in the transmit data including parity bit is an odd number. The parity bit value should be as follows.

The number of bits with a value of "1" is an odd number in transmit data : 0

The number of bits with a value of "1" is an even number in transmit data : 1

• At reception

The number of bits with a value of "1" contained in the receive data including parity bit are counted, and if this is an even number, a parity error is generated.

(iii) 0 Parity

When transmitting, the parity bit is set to "0" irrespective of the transmit data.

At reception, a parity bit check is not performed. Therefore, a parity error is not generated, irrespective of whether the parity bit is set to "0" or "1".

(iv) No parity

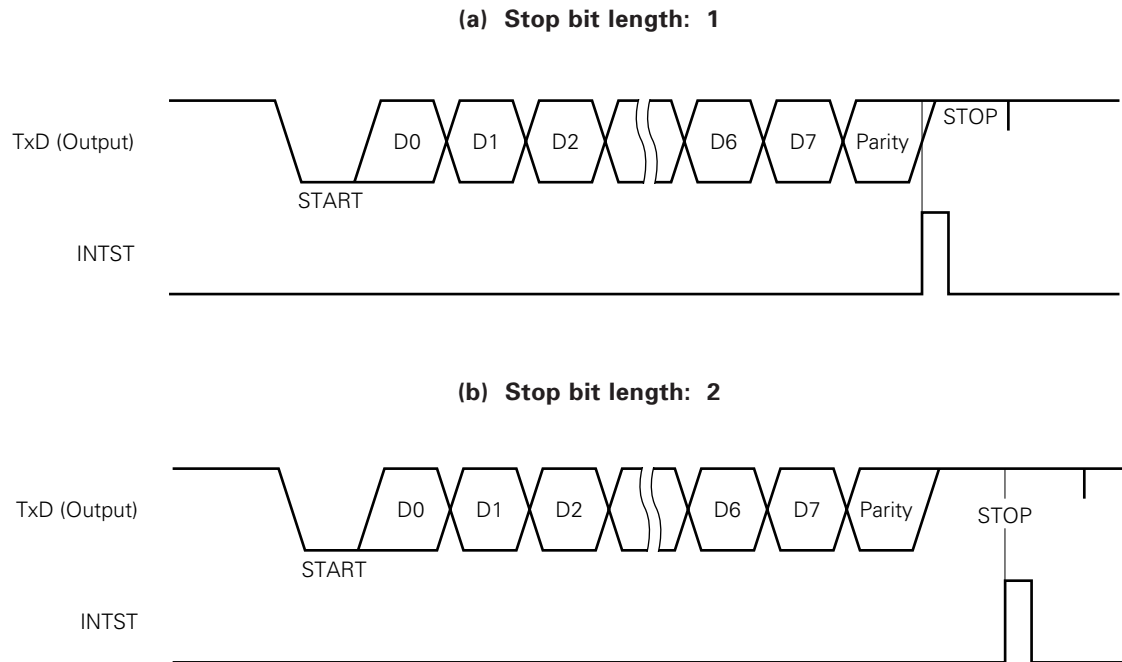
A parity bit is not added to the transmit data. At reception, data is received assuming that there is no parity bit. Since there is no parity bit, a parity error is not generated.

(c) Transmission

A transmit operation is started by writing transmit data to the transmit shift register (TXS). The start bit, parity bit and stop bit(s) are added automatically.

When the transmit operation starts, the data in the transmit shift register (TXS) is shifted out, and when the transmit shift register (TXS) is empty, a transmission completion interrupt (INTST) is generated.

Figure 17-8. Asynchronous Serial Interface Transmission Completion Interrupt Timing



Caution Rewriting of the asynchronous serial interface mode register (ASIM) should not be performed during a transmit operation. If rewriting of the ASIM register is performed during transmission, subsequent transmit operations may not be possible (the normal state is restored by $\overline{\text{RESET}}$ input).

It is possible to determine whether transmission is in progress by software by using a transmission completion interrupt (INTST) or the interrupt request flag (STIF) set by the INTST.

(d) Reception

When the RXE bit of the asynchronous serial interface mode register (ASIM) is set (1), a receive operation is enabled and sampling of the RxD pin input is performed.

RxD pin input sampling is performed using the serial clock specified by ASIM.

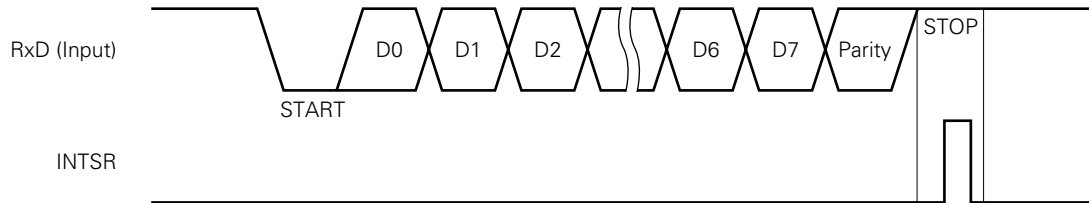
When the RxD pin input becomes low, the 5-bit counter starts counting, and at the time when the half time determined by specified baud rate has passed, the data sampling start timing signal is output. If the RxD pin input sampled again as a result of this start timing signal is low, it is identified as a start bit, the 5-bit counter is initialized and starts counting, and data sampling is performed. When character data, a parity bit and one stop bit are detected after the start bit, reception of one frame of data ends.

When one frame of data has been received, the receive data in the shift register is transferred to the receive buffer register (RXB), and a reception completion interrupt (INTSR) is generated.

If an error is generated, the receive data in which the error was generated is still transferred to RXB, and INTSR is generated.

If the RXE bit is reset (0) during the receive operation, the receive operation is stopped immediately. In this case, the contents of RXB and ASIS are not changed, and INTSR and INTSER are not generated.

Figure 17-9. Asynchronous Serial Interface Reception Completion Interrupt Timing



Caution The receive buffer register (RXB) must be read even if a receive error is generated. If RXB is not read, an overrun error will be generated when the next data is received, and the receive error state will continue indefinitely.

(e) Receive errors

Three kinds of errors can occur during a receive operation: a parity error, framing error, or overrun error. The data reception result error flag is set in the asynchronous serial interface status register (ASIS) and at the same time a receive error interrupt (INTSER) is generated. Receive error causes are shown in Table 17-7.

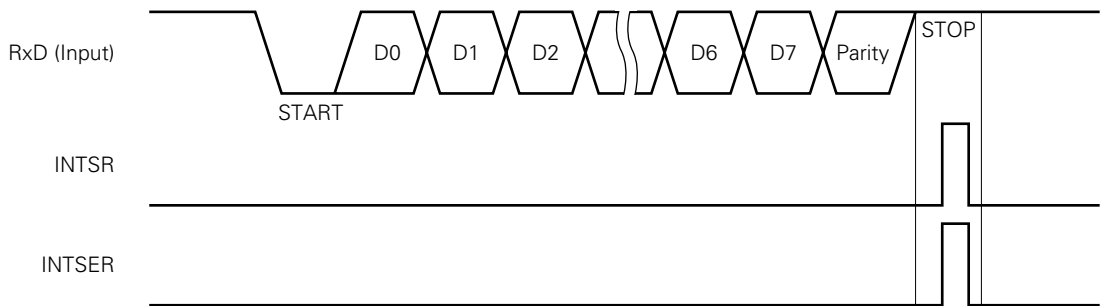
It is possible to determine what kind of error was generated during reception by reading the contents of the asynchronous serial interface status register (ASIS) in the reception error interrupt servicing (INTSER) (see **Figures 17-9** and **17-10**).

The contents of ASIS are reset (0) by reading the receive buffer register (RXB) or receiving the next data (if there is an error in the next data, the corresponding error flag is set).

Table 17-7. Receive Error Causes

Receive Errors	Cause
Parity error	Transmission-time parity specification and reception data parity do not match
Framing error	Stop bit not detected
Overrun error	Reception of next data is completed before data is read from receive register buffer

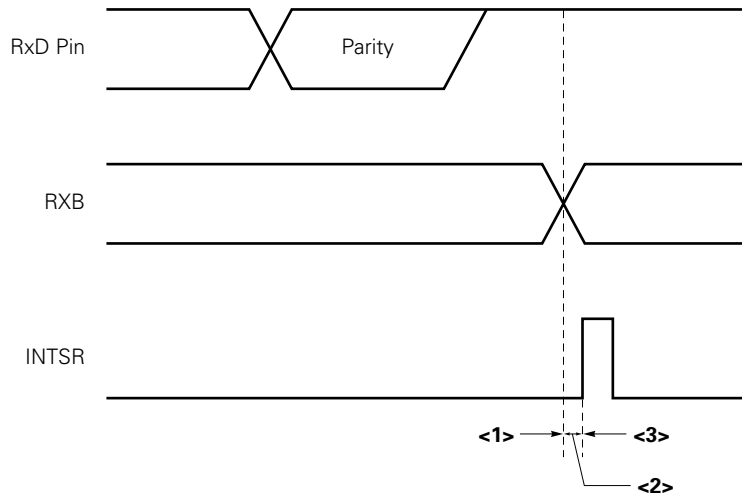
Figure 17-10. Receive Error Timing



- Cautions**
- 1. The contents of the ASIS register are reset (0) by reading the receive buffer register (RXB) or receiving the next data. To ascertain the error contents, ASIS must be read before reading RXB.**
 - 2. The receive buffer register (RXB) must be read even if a receive error is generated. If RXB is not read, an overrun error will be generated when the next data is received, and the receive error state will continue indefinitely.**

(3) UART mode cautions

- (a) When bit 7 (TXE) of the asynchronous serial interface mode register (ASIM) is cleared during transmission, be sure to set the transmit shift register (TXS) to FFH, then set the TXE to 1 before executing the next transmission.
- (b) When bit 6 (RXE) of the asynchronous serial interface mode register (ASIM) is cleared during reception, receive buffer register (RXB) and receive completion interrupt (INTSR) are as follows.



When RXE is set to 0 at a time indicated by <1>, RXB holds the previous data and does not generate INTSR.
 When RXE is set to 0 at a time indicated by <2>, RXB renews the data and does not generate INTSR.
 When RXE is set to 0 at a time indicated by <3>, RXB renews the data and generates INTSR.

17.4.3 3-wire serial I/O mode

The 3-wire serial I/O mode is useful for connection of peripheral I/Os and display controllers, etc., which incorporate a conventional synchronous clocked serial interface, such as the 75X series, 78K series, 17K series, etc.

Communication is performed using three lines: the serial clock ($\overline{SCK2}$), serial output (SO2), and serial input (SI2).

(1) Register setting

3-wire serial I/O mode settings are performed using serial operating mode register 2 (CSIM2), the asynchronous serial interface mode register (ASIM), and the baud rate generator control register (BRGC). *

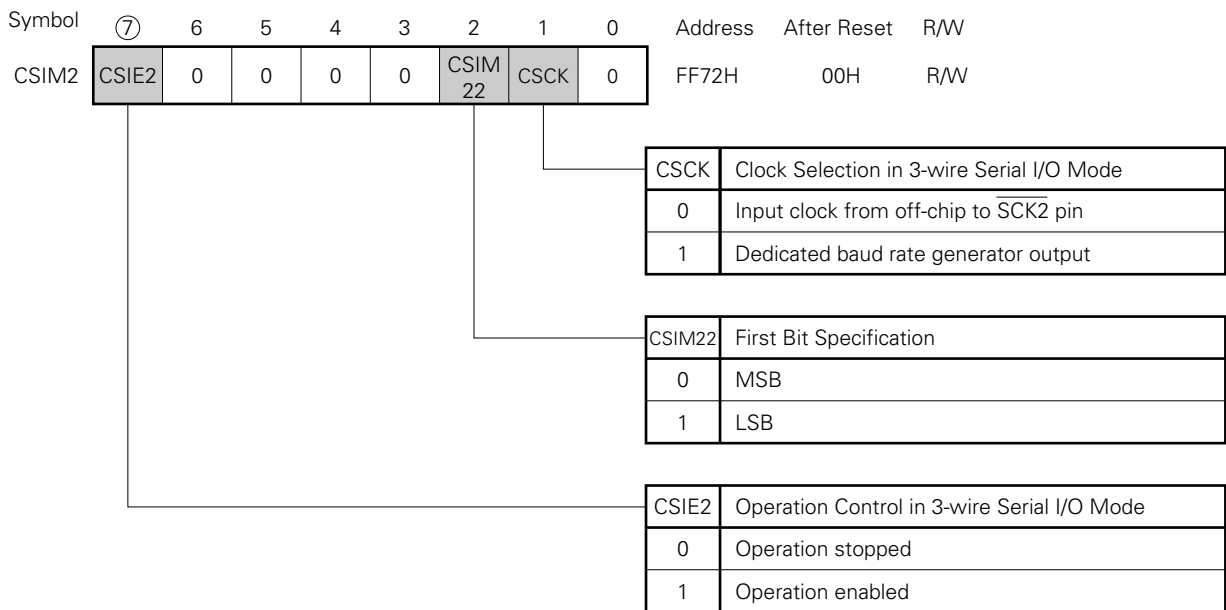
(a) Serial operating mode register 2 (CSIM2)

CSIM2 is set with a 1-bit or 8-bit memory manipulation instruction.

\overline{RESET} input sets CSIM2 to 00H.

The bits used in the 3-wire serial I/O mode are indicated by shading.

www.DataSheet4U.com



Caution Ensure that bit 0 and bit 3 to bit 6 are set to 0.

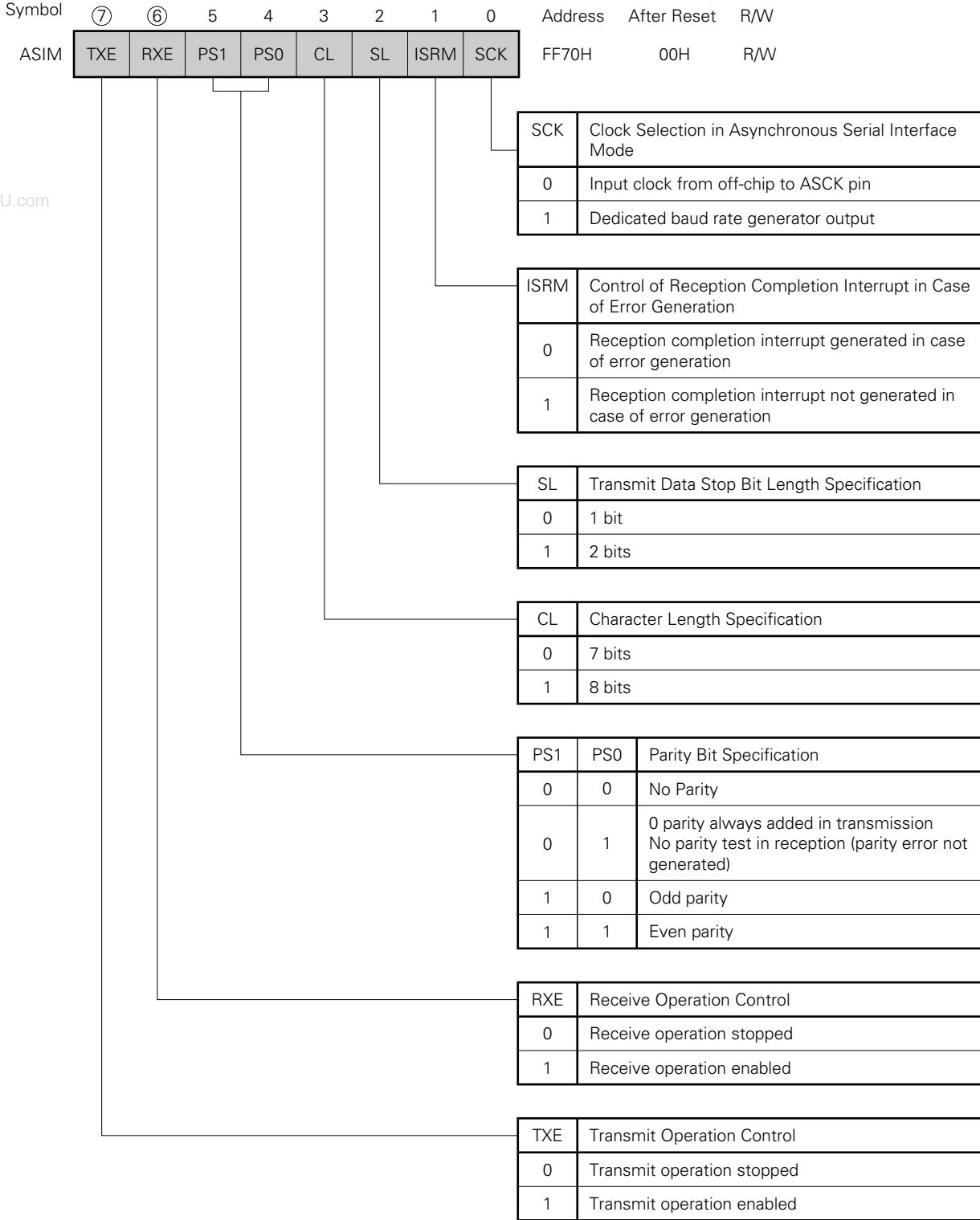
(b) Asynchronous serial interface mode register (ASIM)

ASIM is set with a 1-bit or 8-bit memory manipulation instruction.

$\overline{\text{RESET}}$ input sets ASIM to 00H.

The bits used in the 3-wire serial I/O mode are indicated by shading.

When the 3-wire serial I/O mode is selected, 00H should be set in ASIM.



www.DataSheet4U.com

(c) Baud rate generator control register (BRGC)

BRGC is set with an 8-bit memory manipulation instruction.

$\overline{\text{RESET}}$ input sets BRGC to 00H.

The bits used in the UART mode are indicated by shading.

Symbol	7	6	5	4	3	2	1	0	Address	After Reset	R/W
BRGC	TPS3	TPS2	TPS1	TPS0	MDL3	MDL2	MDL1	MDL0	FF73H	00H	R/W

MDL3	MDL2	MDL1	MDL0	Baud Rate Generator Input Clock Selection	k
0	0	0	0	f _{sck} /16	0
0	0	0	1	f _{sck} /17	1
0	0	1	0	f _{sck} /18	2
0	0	1	1	f _{sck} /19	3
0	1	0	0	f _{sck} /20	4
0	1	0	1	f _{sck} /21	5
0	1	1	0	f _{sck} /22	6
0	1	1	1	f _{sck} /23	7
1	0	0	0	f _{sck} /24	8
1	0	0	1	f _{sck} /25	9
1	0	1	0	f _{sck} /26	10
1	0	1	1	f _{sck} /27	11
1	1	0	0	f _{sck} /28	12
1	1	0	1	f _{sck} /29	13
1	1	1	0	f _{sck} /30	14
1	1	1	1	f _{sck}	—

Remark f_{sck} : 5-bit counter source clock
 k : Value set in MDL0 to MDL3 (0 ≤ k ≤ 14)

TPS3	TPS2	TPS1	TPS0	5-Bit Counter Source Clock Selection				n
				MCS=1		MCS=0		
0	0	0	0	$f_{xx}/2^{10}$	$f_x/2^{10}$ (4.9 kHz)	$f_x/2^{11}$ (2.4 kHz)		11
0	1	0	1	f_{xx}	f_x (5.0 MHz)	$f_x/2$ (2.5 MHz)		1
0	1	1	0	$f_{xx}/2$	$f_x/2$ (2.5 MHz)	$f_x/2^2$ (1.25 MHz)		2
0	1	1	1	$f_{xx}/2^2$	$f_x/2^2$ (1.25 MHz)	$f_x/2^3$ (625 kHz)		3
1	0	0	0	$f_{xx}/2^3$	$f_x/2^3$ (625 kHz)	$f_x/2^4$ (313 kHz)		4
1	0	0	1	$f_{xx}/2^4$	$f_x/2^4$ (313 kHz)	$f_x/2^5$ (156 kHz)		5
1	0	1	0	$f_{xx}/2^5$	$f_x/2^5$ (156 kHz)	$f_x/2^6$ (78.1 kHz)		6
1	0	1	1	$f_{xx}/2^6$	$f_x/2^6$ (78.1 kHz)	$f_x/2^7$ (39.1 kHz)		7
1	1	0	0	$f_{xx}/2^7$	$f_x/2^7$ (39.1 kHz)	$f_x/2^8$ (19.5 kHz)		8
1	1	0	1	$f_{xx}/2^8$	$f_x/2^8$ (19.5 kHz)	$f_x/2^9$ (9.8 kHz)		9
1	1	1	0	$f_{xx}/2^9$	$f_x/2^9$ (9.8 kHz)	$f_x/2^{10}$ (4.9 kHz)		10
Other than above				Setting prohibited				

Caution When a write is performed to BRGC during a communication operation, baud rate generator output is disrupted and communication cannot be performed normally. Therefore, BRGC must not be written to during a communication operation.

- Remarks**
1. f_x : Main system clock oscillation frequency
 2. f_{xx} : Main system clock frequency (f_x or $f_x/2$)
 3. MCS : Oscillation mode selection register bit 0
 4. n : Value set in TPS0 to TPS3 ($1 \leq n \leq 11$)
 5. Figures in parentheses apply to operation with $f_x = 5.0$ MHz.

When the internal clock is used as the serial clock in the 3-wire serial I/O mode, set BRGC as described below. BRGC Setting is not required if an external serial clock is used.

(i) When the baud rate generator is not used:

Select a serial clock frequency with TPS0-TPS3. Be sure then to set MDL0 to MDL3 to 1,1,1,1.

The serial clock frequency becomes the same as the source clock frequency for the 5-bit counter.

(ii) When the baud rate generator is used:

Select a serial clock frequency with MDL0-MDL3 and TPS0-TPS3. Be sure then to set MDL0 to MDL3 to a value other than 1,1,1,1.

The serial clock frequency is calculated by the following formula:

$$\text{Serial clock frequency} = \frac{f_{xx}}{2^n \times (k + 16)} \text{ [Hz]}$$

f_x : Main system clock oscillation frequency

f_{xx} : Main system clock frequency (f_x or $f_x/2$)

n : Value set in TPS0 to TPS3 ($1 \leq n \leq 11$)

k : Value set in MDL0 to MDL3 ($0 \leq k \leq 14$)

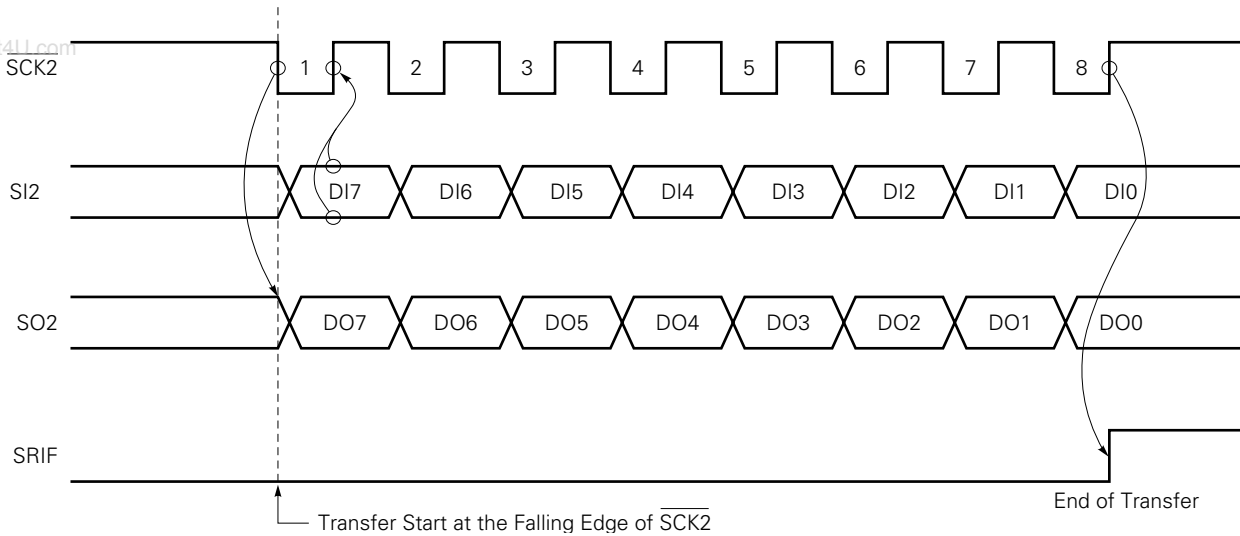
(2) Communication operation

In the 3-wire serial I/O mode, data transmission/reception is performed in 8-bit units. Data is transmitted/received bit by bit in synchronization with the serial clock.

Transmit shift register (TXS/SIO2) and receive shift register (RXS) shift operations are performed in synchronization with the fall of the serial clock ($\overline{SCK2}$). Then transmit data is held in the SO2 latch and output from the SO2 pin. Also, receive data input to the SI2 pin is latched in the receive buffer register (RXB/SIO2) on the rise of $\overline{SCK2}$.

At the end of an 8-bit transfer, the operation of the transmit shift register (TXS/SIO2) or receive shift register (RXS) stops automatically, and the interrupt request flag (SRIF) is set.

Figure 17-11. 3-Wire Serial I/O Mode Timing



*** (3) Transfer start**

Serial transfer is started by setting transfer data to the transmission shift register (TXS/SIO2) when the following two conditions are satisfied.

- Serial interface channel 2 operation control bit (CSIE2) = 1
- Internal serial clock is stopped or SCK2 is a high level after 8-bit serial transfer.

Caution If CSIE2 is set to "1" after data write to TXS/SIO2, transfer does not start.

Upon termination of 8-bit transfer, serial transfer automatically stops and the interrupt request flag (SRIF) is set.

CHAPTER 18 LCD CONTROLLER/DRIVER

18.1 LCD Controller/Driver Functions

The functions of the LCD controller/driver incorporated in the μ PD78064, 78064Y subseries are shown below.

- (1) Automatic output of segment signals and common signals is possible by automatic reading of the display data memory.
- (2) Any of five display modes can be selected.
 - Static
 - 1/2 duty (1/2 bias)
 - 1/3 duty (1/2 bias)
 - 1/3 duty (1/3 bias)
 - 1/4 duty (1/3 bias)
- (3) Any of four frame frequencies can be selected in each display mode.
- (4) Maximum of 40 segment signal outputs (S0 to S39); 4 common signal outputs (COM0 to COM3). Sixteen of the segment signal outputs can be switched to input/output ports in units of 2 (P80/S39 to P87/S32, P90/S31 to P97/S24).
- (5) In mask ROM versions, split resistors for LCD drive voltage generation can be incorporated by mask option.
- (6) Operation on the subsystem clock is also possible.

The maximum number of displayable pixels in each display mode is shown in Table 18-1.

Table 18-1. Maximum Number of Display Pixels

Bias Method	Time Division	Common Signals Used	Maximum Number of Pixels	Note
–	Static	COM0 (COM1, 2, 3)	40 (40 segments x 1 common)	1
1/2	2	COM0, COM1	80 (40 segments x 2 commons)	2
	3	COM0-COM2	120 (40 segments x 3 commons)	3
1/3	3	COM0-COM2	120 (40 segments x 3 commons)	3
	4	COM0-COM3	160 (40 segments x 4 commons)	4

- Notes**
1. 5 digits on \bar{g} type LCD panel with 8 segments/digit.
 2. 10 digits on \bar{g} type LCD panel with 4 segments/digit.
 3. 13 digits on \bar{g} type LCD panel with 3 segments/digit.
 4. 20 digits on \bar{g} type LCD panel with 2 segments/digit.

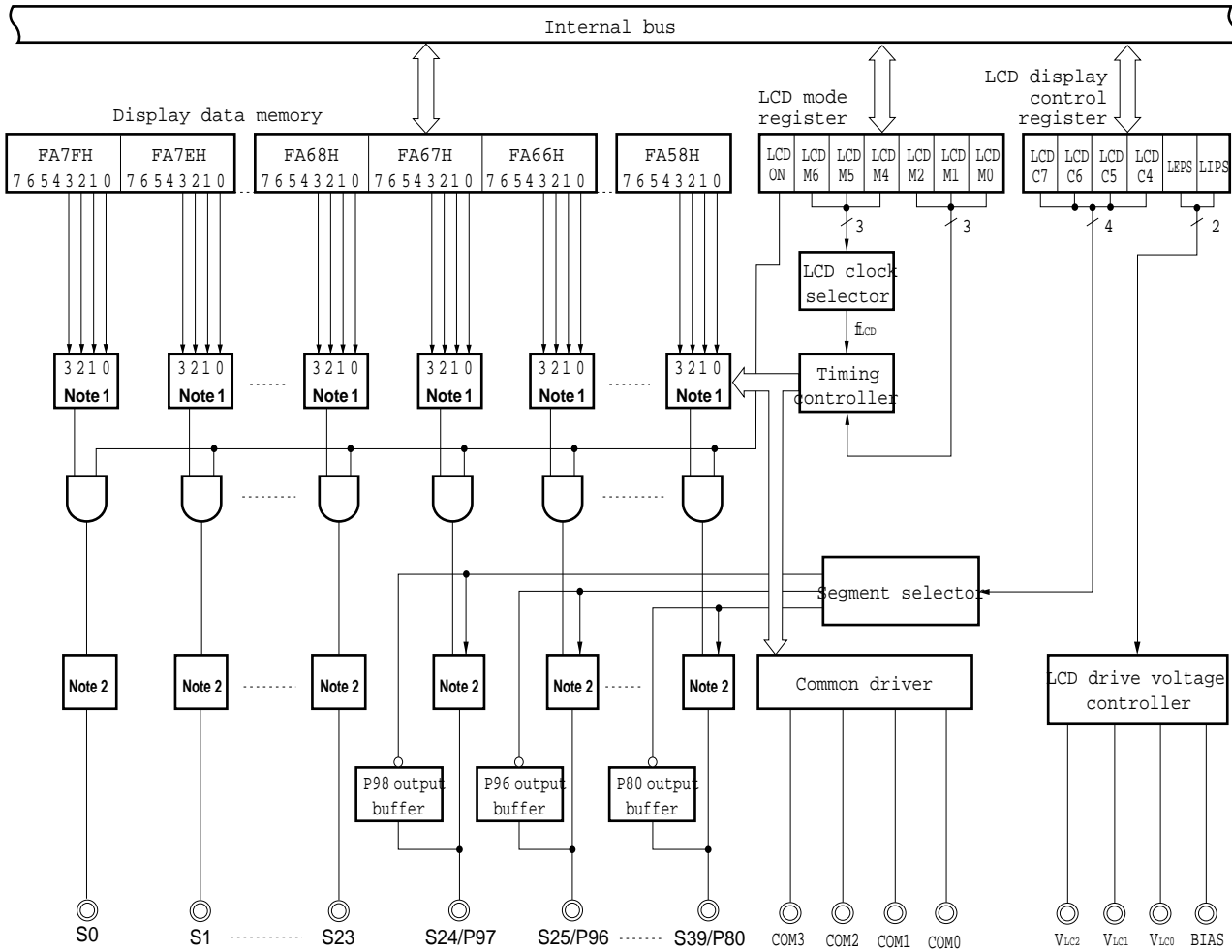
18.2 LCD Controller/Driver Configuration

The LCD controller/driver is composed of the following hardware.

Table 18-2. LCD Controller/Driver Configuration

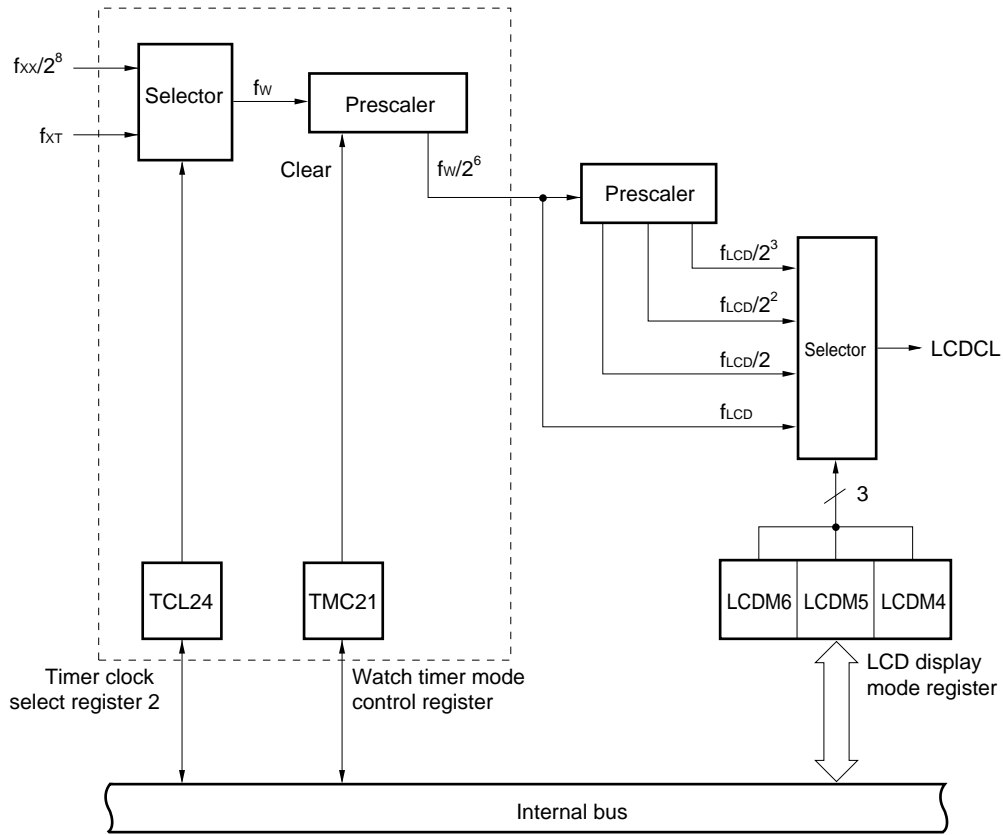
Item	Configuration
Display outputs	Segment signals : 40 Dedicated segment signals: 24 Segment signal/input/output port dual function: 16 Common signals : 4 (COM0 to COM3)
Control registers	LCD display mode register (LCDM) LCD display control register (LCDC)

Figure 18-1. LCD Controller/Driver Block Diagram



- Notes**
1. Selector
 2. Segment driver

Figure 18-2. LCD Clock Select Circuit Block Diagram



- Remarks**
1. The clock timer includes the circuit enclosed with the dotted line.
 2. LCDCL : LCD clock
 3. f_{LCD} : LCD clock frequency

18.3 LCD Controller/Driver Control Registers

The LCD controller/driver is controlled by the following two registers.

- LCD display mode register (LCDM)
- LCD display control register (LCDC)

(1) LCD display mode register (LCDM)

This register sets display operation enabling/ disabling, the LCD clock, frame frequency, and display mode selection.

LCDM is set by a 1-bit or 8-bit memory manipulation instruction.

RESET input sets LCDM to 00H.

Figure 18-3. LCD Display Mode Register Format

Symbol	⑦	6	5	4	3	2	1	0	Address	State after reset	R/W
LCDM	LCDON	LCDM6	LCDM5	LCDM4	0	LCDM2	LCDM1	LCDM0	FFB0H	00H	R/W

LCDM2	LCDM1	LCDM0	Number of Time Divisions	Bias Method
0	0	0	4	1/3
0	0	1	3	1/3
0	1	0	2	1/2
0	1	1	3	1/2
1	0	0	Static	
Other than above			Setting prohibited	

LCDM5	LCDM5	LCDM4	LCD Clock Selection (See Note)		
			$f_{xx} = 5.0 \text{ MHz}$	$f_{xx} = 4.19 \text{ MHz}$	$f_{xT} = 32.768 \text{ kHz}$
0	0	0	$f_w/2^9$ (76 Hz)	$f_w/2^9$ (64 Hz)	$f_w/2^9$ (64 Hz)
0	0	1	$f_w/2^8$ (153 Hz)	$f_w/2^8$ (128 Hz)	$f_w/2^8$ (128 Hz)
0	1	0	$f_w/2^7$ (305 Hz)	$f_w/2^7$ (256 Hz)	$f_w/2^7$ (256 Hz)
0	1	1	$f_w/2^6$ (610 Hz)	$f_w/2^6$ (512 Hz)	$f_w/2^6$ (512 Hz)

LCDON	LCD Display
0	Display on (All segment outputs signal non-selection.)
1	Display off

Note The LCD clock is supplied from the clock timer. When LCD display is performed, 1 should be set in bit 1 (TMC21) of the clock timer mode control register (TMC2). If TMC21 is reset to 0 during LCD display, the LCD clock supply will be stopped and the display will be disrupted.

- Remarks**
1. f_w : Clock timer clock frequency ($f_{xx}/2^7$ or f_{xT})
 2. f_{xx} : Main system clock frequency (f_x or $f_x/2$)
 3. f_x : Main system clock oscillation frequency
 4. f_{xT} : Subsystem clock oscillation frequency

Table 18-3. Frame Frequencies (Hz)

Duty \ LCDCL	$f_w/2^9$ (64 Hz)	$f_w/2^8$ (128 Hz)	$f_w/2^7$ (256 Hz)	$f_w/2^6$ (512 Hz)
Static	64	128	256	512
1/2	32	64	128	256
1/3	21	43	85	171
1/4	16	32	64	128

- Remarks**
1. Figures in parentheses apply to operation with $f_x = 4.19$ MHz or $f_{XT} = 32.768$ kHz.
 2. f_w : Clock timer clock frequency ($f_{xx}/2^7$ or f_{XT})
 3. f_{xx} : Main system clock frequency (f_x or $f_x/2$)
 4. f_x : Main system clock oscillation frequency
 5. f_{XT} : Subsystem clock oscillation frequency

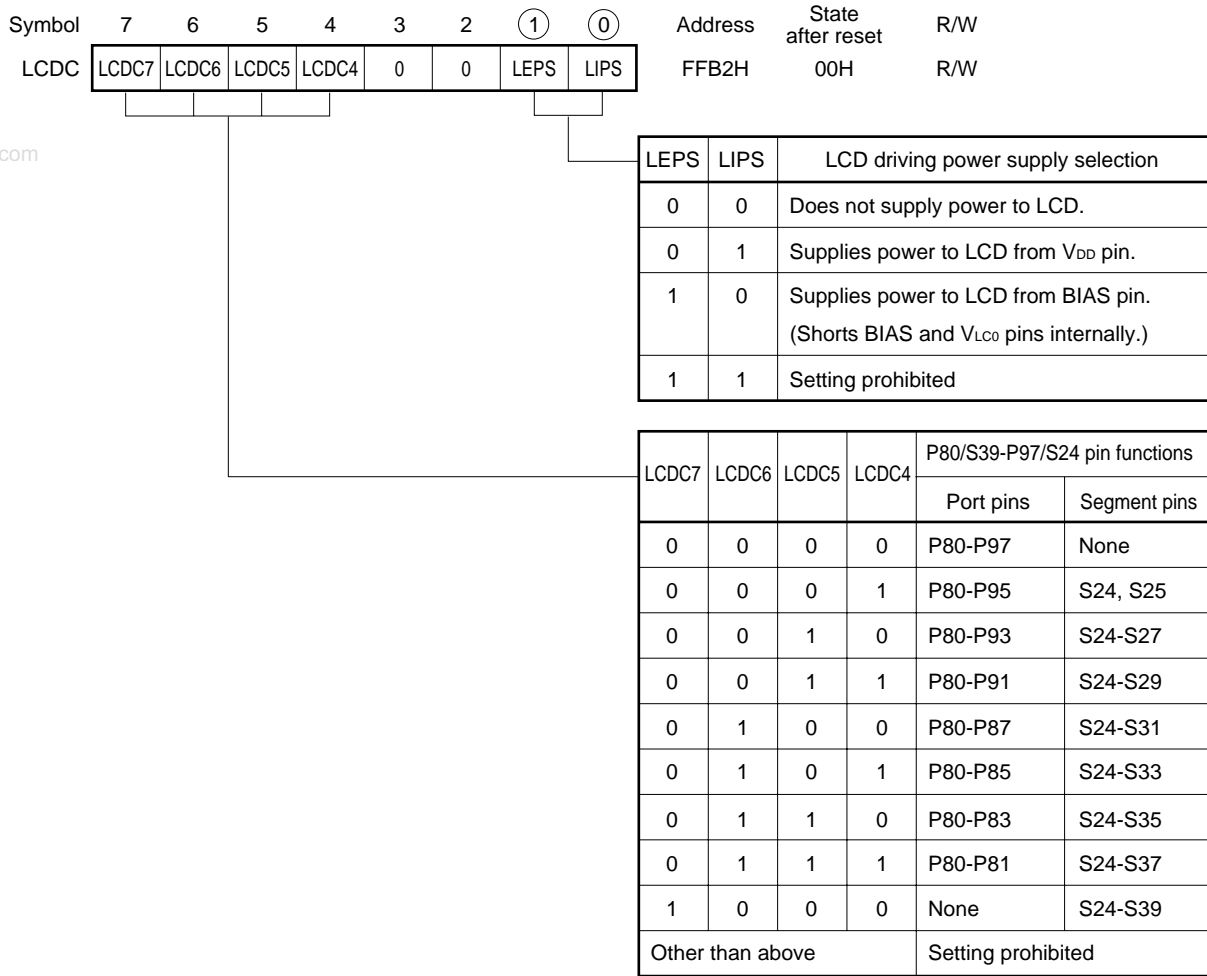
(2) LCD display control register (LCDC)

This register sets cut-off of the current flowing to split resistors for LCD drive voltage generation and switchover between segment output and input/output port functions.

LCDC is set by a 1-bit or 8-bit memory manipulation instruction.

$\overline{\text{RESET}}$ input sets LCDC to 00H.

Figure 18-4. LCD Display Control Register Format



- Cautions**
1. Pins which perform segment output cannot be used as output port pins even if 0 is set in the port register.
 2. If a pin which performs segment output is read as a port, its value will be 0.
 3. Pins set as segment outputs by LCDC cannot have an internal pull-up resistor connected regardless of the value of bits 0 and 1 (PU08 and PU09) of pull-up resistor option register H.

18.4 LCD Controller/Driver Settings

LCD controller/driver settings should be performed as shown below. When the LCD controller/driver is used, the clock timer should be set to the operational state beforehand.

- <1>Set "watch operation enabled" in timer clock selection register 2 (TCL2) and the clock timer mode control register (TMC2).
- <2>Set the initial value in the display data memory (FA58H to FA7FH).
- <3>Set the pins to be used as segment outputs in the LCD display control register (LCDC).
- <4>Set the display mode and LCD clock in the LCD display mode register (LCDM).

www.DataSheet4U.com

Next, set data in the display data memory according to the display contents.

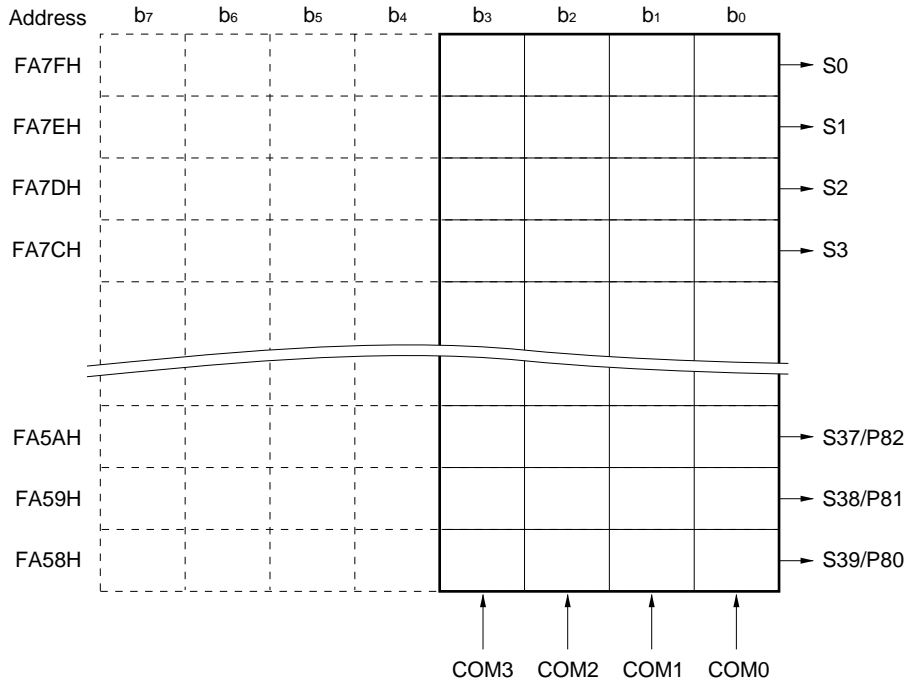
18.5 LCD Display Data Memory

The LCD display data memory is mapped onto addresses FA58H to FA7FH. The data stored in the LCD display data memory can be displayed on an LCD panel by the LCD controller/driver.

Figure 18-5 shows the relationship between the LCD display data memory contents and the segment outputs/common outputs.

Any area not used for display can be used as normal RAM.

Figure 18-5. Relationship between LCD Display Data Memory Contents and Segment/Common Outputs



Caution The higher 4 bits of the LCD display data memory do not incorporate memory. Be sure to set them to 0.

18.6 Common Signals and Segment Signals

An individual pixel on an LCD panel lights when the potential difference of the corresponding common signal and segment signal reaches or exceeds a given voltage (the LCD drive voltage V_{LCD}).

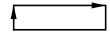
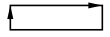
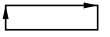
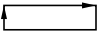
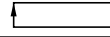
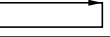
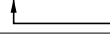
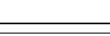
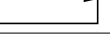


As an LCD panel deteriorates if a DC voltage is applied in the common signals and segment signals, it is driven by AC voltage.

(1) Common signals

For common signals, the selection timing order is as shown in Table 18-4 according to the number of time divisions set, and operations are repeated with these as the cycle. In the static mode, the same signal is output to COM0 through COM3.

With 2-time-division operation, pins COM2 and COM3 are left open, and with 3-time-division operation, the COM3 pin is left open.

Table 18-4. COM Signals

COM signal Time division	COM0	COM1	COM2	COM3
Static				
2-time division			Open	Open
3-time division				Open
4-time division				

(2) Segment signals

Segment signals correspond to a 40-byte LCD display data memory (FA58H to FA7FH). Each display data memory bit 0, bit 1, bit 2, and bit 3 is read in synchronization with the COM0, COM1, COM2 and COM3 timings respectively, and if the value of the bit is 1, it is converted to the selection voltage. If the value of the bit is 0, it is converted to the non-selection voltage and output to a segment pin (S0 to S39) (S24 to S39 have a dual function as input/output port pins).

Consequently, it is necessary to check what combination of front surface electrodes (corresponding to the segment signals) and rear surface electrodes (corresponding to the common signals) of the LCD display to be used form the display pattern, and then write bit data corresponding on a one-to-one basis with the pattern to be displayed.

In addition, because LCD display data memory bits 1 and 2 are not used with the static method, bits 2 and 3 are not used with the 2-time-division method, and bit 3 is not used with the 3-time-division method, these can be used for other than display purposes.

Bits 4 to 7 are fixed at 0.

(3) Common signal and segment signal output waveforms

The voltages shown in Table 18-5 are output in the common signals and segment signals.

The $\pm V_{LCD}$ ON voltage is only produced when the common signal and segment signal are both at the selection voltage; other combinations produce the OFF voltage.

Table 18-5. LCD Drive Voltages

(a) Static display mode

		Segment	Select	Non-select
		Common	V_{SS}, V_{LC0}	V_{LC0}, V_{SS}
V_{LC0}, V_{SS}			$-V_{LCD}, +V_{LCD}$	$0\text{ V}, 0\text{ V}$

www.DataSheet4U.com

(b) 1/2 bias method

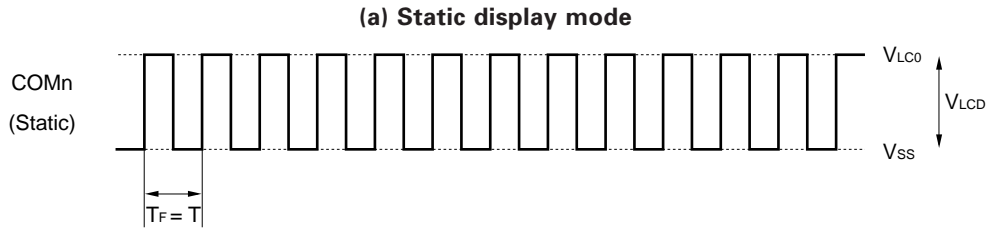
		Segment	Select	Non-select
		Common	V_{SS}, V_{LC0}	V_{LC0}, V_{SS}
Select level	V_{LC0}, V_{SS}		$-V_{LCD}, +V_{LCD}$	$0\text{ V}, 0\text{ V}$
Non-select level	$V_{LC1}=V_{LC2}$		$-1/2V_{LCD}, +1/2V_{LCD}$	$+1/2V_{LCD}, -1/2V_{LCD}$

(c) 1/3 bias method

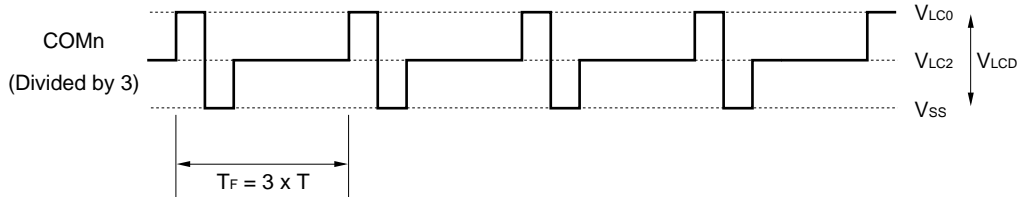
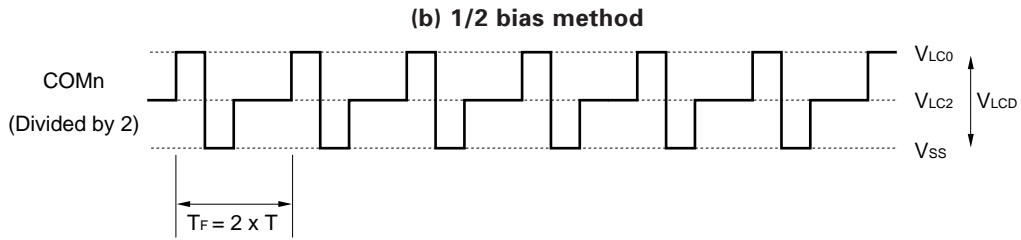
		Segment	Select	Non-select
		Common	V_{SS}, V_{LC0}	V_{LC1}, V_{LC2}
Select level	V_{LC0}, V_{SS}		$-V_{LCD}, +V_{LCD}$	$-1/3V_{LCD}, +1/3V_{LCD}$
Non-select level	V_{LC2}, V_{LC1}		$-1/3V_{LCD}, +1/3V_{LCD}$	$-1/3V_{LCD}, +1/3V_{LCD}$

Figure 18-6 shows the common signal waveform, and Figure 18-7 shows the common signal and segment signal voltages and phases.

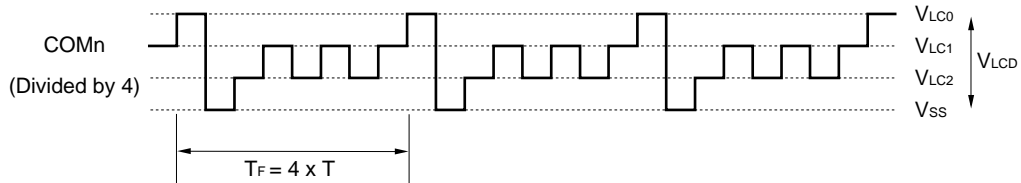
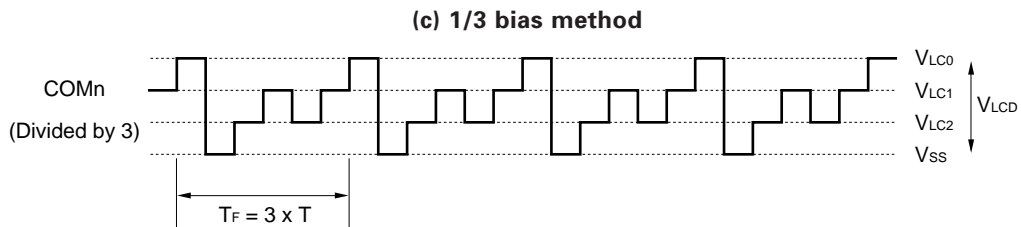
Figure 18-6. Common Signal Waveform



- Remarks**
1. T : One LCDCL cycle
 2. T_F : Frame frequency

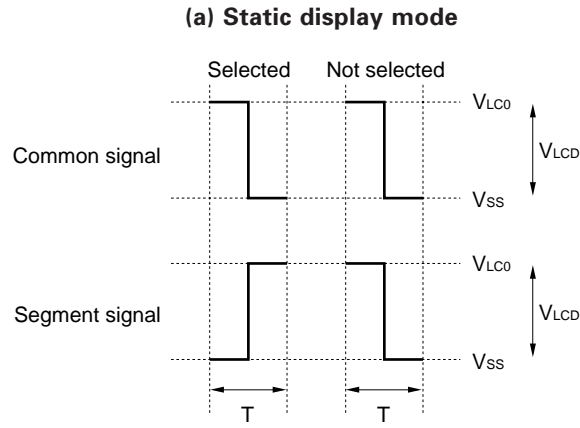


- Remarks**
1. T : One LCDCL cycle
 2. T_F : Frame frequency

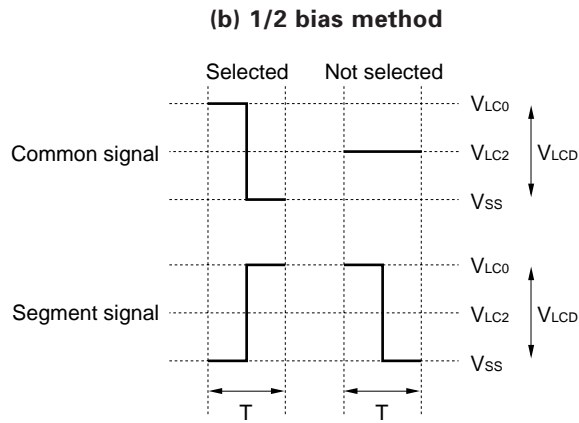


- Remarks**
1. T : One LCDCL cycle
 2. T_F : Frame frequency

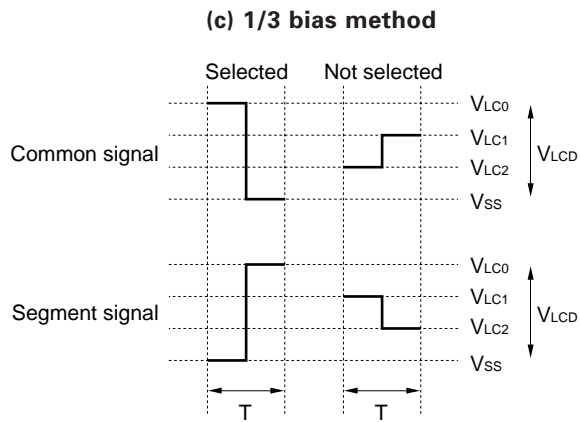
Figure 18-7. Common Signal and Static Signal Voltages and Phases



Remark T : One LCDCL cycle



Remark T : One LCDCL cycle



Remark T : One LCDCL cycle

18.7 Supply of LCD Drive Voltages V_{LC0} , V_{LC1} , V_{LC2}

Split resistors for producing the LCD drive voltages can be incorporated in the μ PD78062, 78063, 78064, 78062Y, 78063Y, and 78064Y by mask option (the μ PD78P064, 78P064Y do not incorporate split resistors). Incorporating the split resistors makes it possible to produce LCD drive voltages appropriate to the various bias methods shown in Table 18-6 without using external split resistors.

Also, an LCD drive voltage can be externally supplied from the BIAS pin to produce other LCD drive voltages.

Table 18-6. LCD Drive Voltages (with On-Chip Split Resistor)

Bias Method LCD Drive Voltage	No bias (static mode)	1/2 bias	1/3 bias
V_{LC0}	V_{LCD}	V_{LCD}	V_{LCD}
V_{LC1}	$2/3V_{LCD}$	$1/2V_{LCD}$ Note	$2/3V_{LCD}$
V_{LC2}	$1/3V_{LCD}$		$1/3V_{LCD}$

Note With the 1/2 bias method, the V_{LC1} pin and V_{LC2} pin must be connected externally.

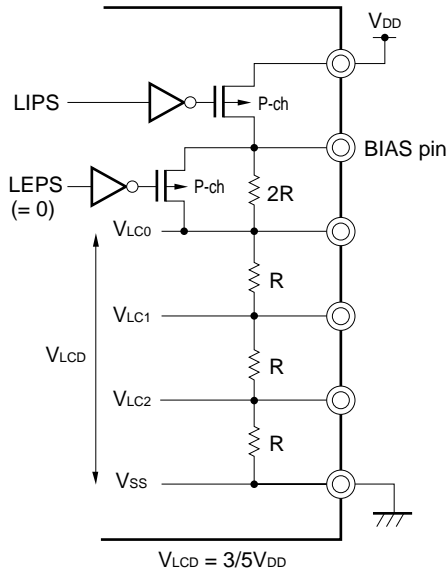
Remarks 1. When the BIAS pin and V_{LC0} pin are open, $V_{LCD} = 3/5V_{DD}$ (with on-chip split resistor).

2. When the BIAS pin and V_{LC0} pin are connected, $V_{LCD} = V_{DD}$.

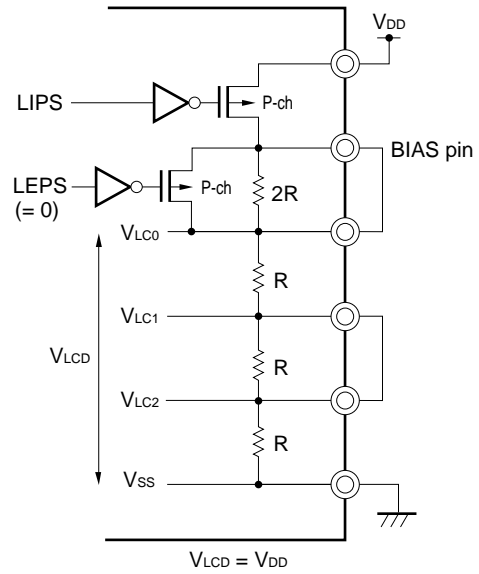
Examples of internal supply of the LCD drive voltage in accordance with Table 18-6 are shown in Figures 18-8 and 18-9. An example of supply of the LCD drive voltage from off-chip is shown in Figure 18-10. Stepless LCD drive voltages can be supplied by means of variable resistor r .

Figure 18-8. LCD Drive Power Supply Connection Examples (with On-Chip Split Resistor)

(a) 1/3 bias method and static display mode
(Example with $V_{DD} = 5\text{ V}$, $V_{LCD} = 3\text{ V}$)



(b) 1/2 bias method mode
(Example with $V_{DD} = 5\text{ V}$, $V_{LCD} = 5\text{ V}$)



(c) 1/3 bias method and static display mode
(Example with $V_{DD} = 5\text{ V}$, $V_{LCD} = 5\text{ V}$)

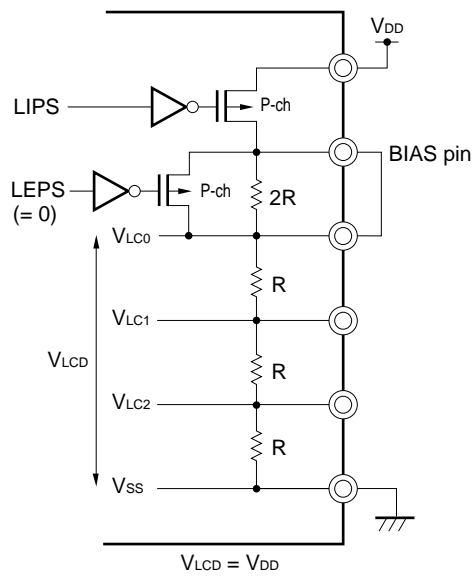
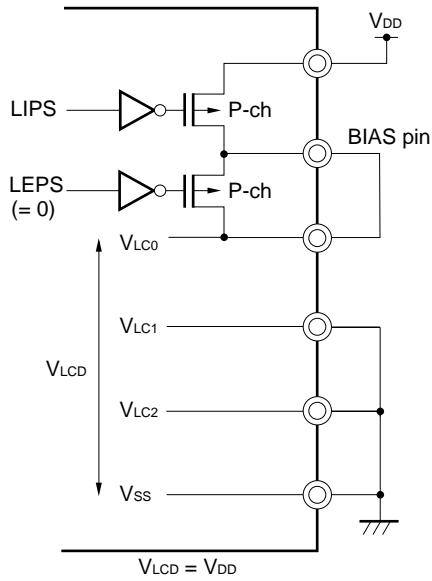
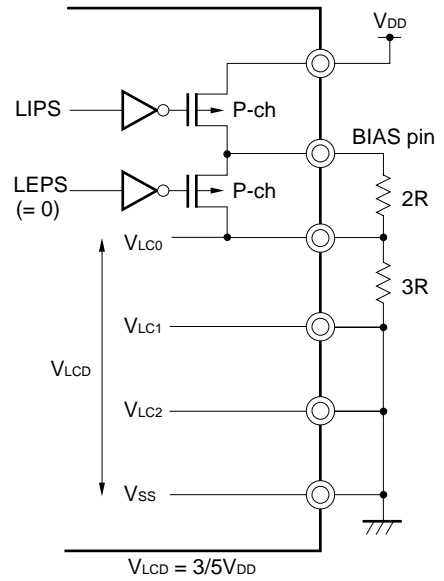


Figure 18-9. LCD Drive Power Supply Connection Examples (with External Split Resistor)

(a) **Static display mode** ^{Note}
 (Example with $V_{DD} = 5\text{ V}$, $V_{LCD} = 5\text{ V}$)

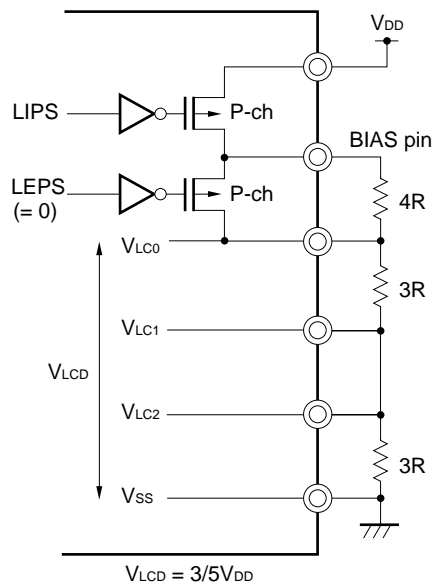


(b) **Static display mode**
 (Example with $V_{DD} = 5\text{ V}$, $V_{LCD} = 3\text{ V}$)



Note LIPS should always be set to 1 (including in standby mode).

(c) **1/2 bias method**
 (Example with $V_{DD} = 5\text{ V}$, $V_{LCD} = 3\text{ V}$)



(d) **1/3 bias method**
 (Example with $V_{DD} = 5\text{ V}$, $V_{LCD} = 3\text{ V}$)

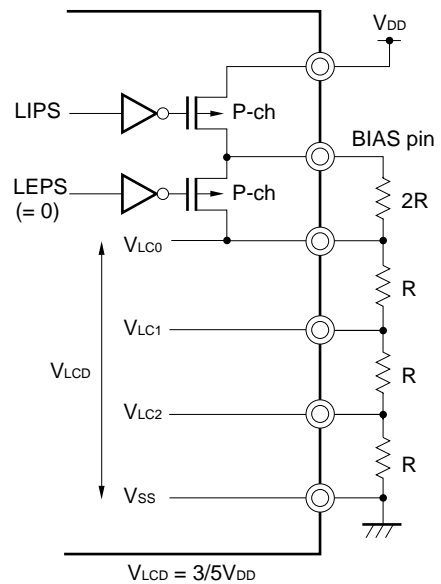
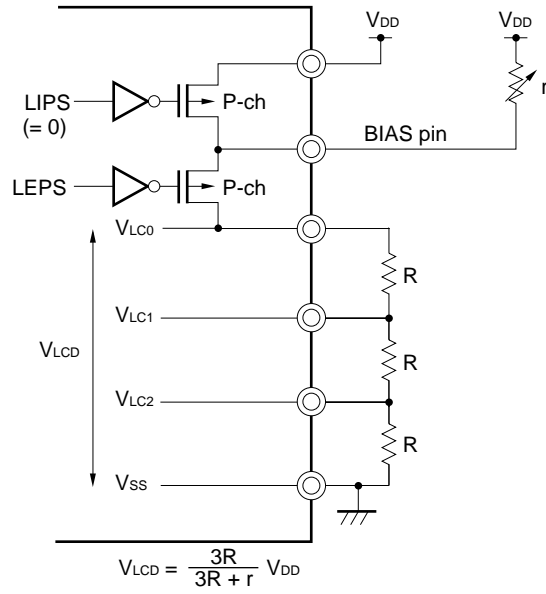


Figure 18-10. Example of LCD Drive Voltage Supply from Off-Chip



www.DataSheet4U.com

18.8 Display Modes

18.8.1 Static Display Example

Figure 18-12 shows the connection of a static type 5-digit LCD panel with the display pattern shown in Figure 18-11 with the μ PD78064 subseries segment (S0 to S39) and common (COM0) signals. The display example is "123.45," and the display data memory contents (addresses FA58H to FA7FH) correspond to this.

An explanation is given here taking the example of the third digit "3." (3.). In accordance with the display pattern in Figure 18-11, selection and non-selection voltages must be output to pins S16 through S23 as shown in Table 18-7 at the COM0 common signal timing.

Table 18-7. Selection and Non-Selection Voltages (COM0)

Segment	S16	S17	S18	S19	S20	S21	S22	S23
Common								
COM0	S	S	S	S	NS	S	NS	S

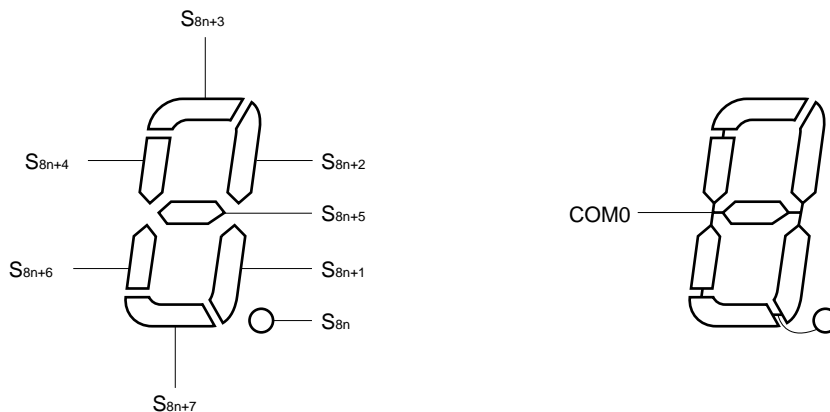
S: Selection, NS: Non-selection

From this, it can be seen that 10101111 must be prepared in the BIT0 bits of the display data memory (addresses FA68H to FA6FH) corresponding to S16 to S23.

The LCD drive waveforms for S19, S20, and COM0 are shown in Figure 18-13. When S19 is at the selection voltage at the timing for selection with COM0, it can be seen that the $+V_{LCD}/-V_{LCD}$ AC square wave, which is the LCD illumination (ON) level, is generated.

Shorting the COM0 through COM3 lines increases the current drive capability because the same waveform as COM0 is output to COM1 through COM3.

Figure 18-11. Static LCD Display Pattern and Electrode Connections



Remark n = 0 to 4

Figure 18-12. Static LCD Panel Connection Example

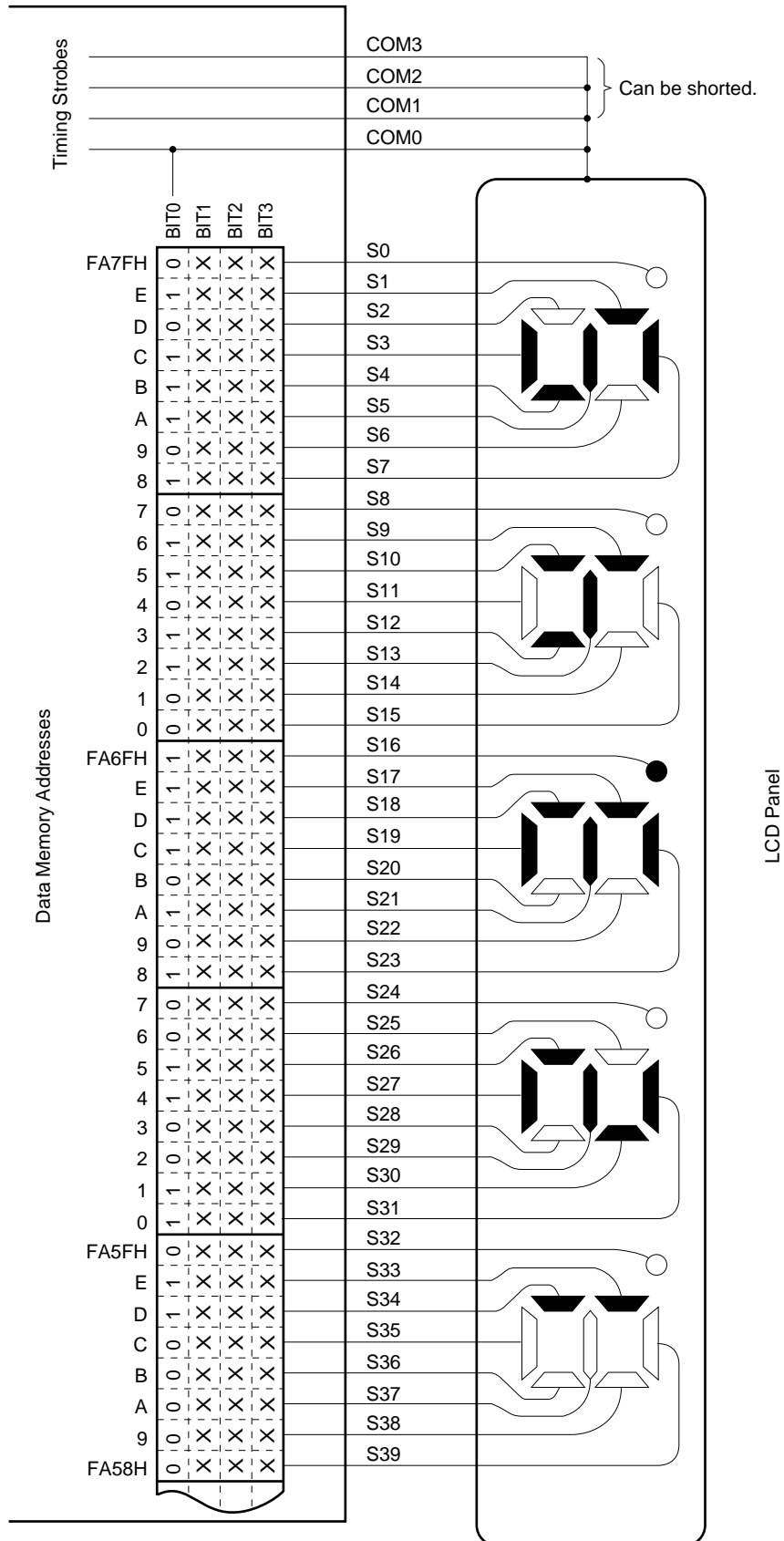
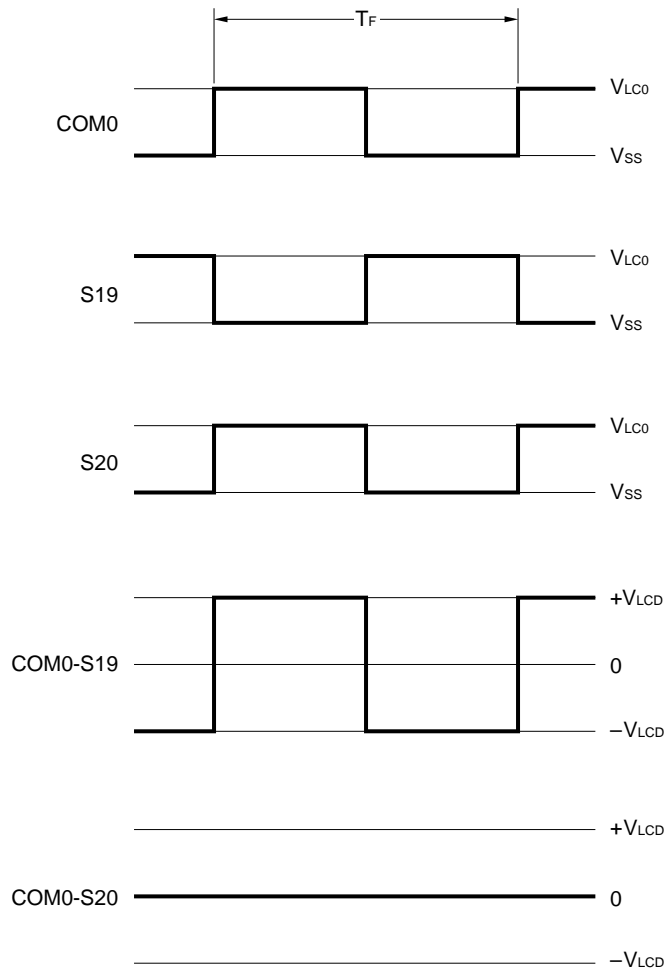


Figure 18-13. Static LCD Drive Waveform Examples



www.DataSheet4U.com

18.8.2 2-Time-Division Display Example

Figure 18-15 shows the connection of a 2-time-division type 10-digit LCD panel with the display pattern shown in Figure 18-14 with the μ PD78064, 78064Y subseries segment signals (S0 to S39) and common signals (COM0, COM1). The display example is "123456.7890," and the display data memory contents (addresses FA58H to FA7FH) correspond to this.

An explanation is given here taking the example of the eighth digit "3" (3). In accordance with the display pattern in Figure 18-14, selection and non-selection voltages must be output to pins S28 through S31 as shown in Table 18-8 at the COM0 and COM1 common signal timings.

Table 18-8. Selection and Non-Selection Voltages (COM0, COM1)

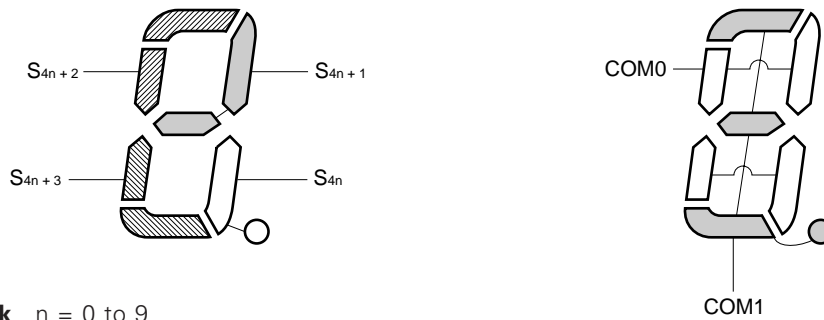
Segment	S28	S29	S30	S31
Common				
COM0	S	S	NS	NS
COM1	NS	S	S	S

S: Selection, NS: Non-selection

From this, it can be seen that, for example, xx10 must be prepared in the display data memory (address FA80H) corresponding to S31.

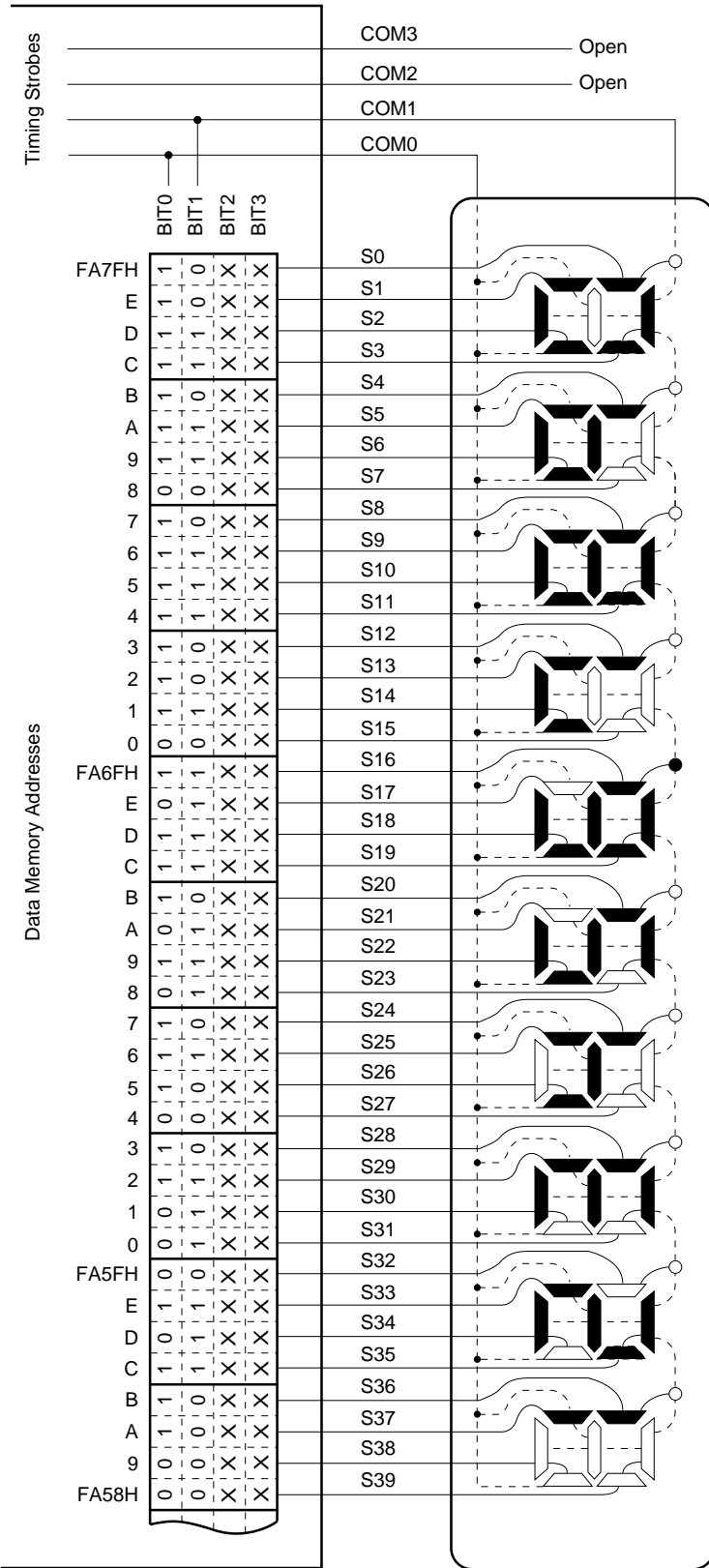
Examples of the LCD drive waveforms between S31 and the common signals are shown in Figure 18-16. When S31 is at the selection voltage at the COM1 selection timing, it can be seen that the $+V_{LCD}/-V_{LCD}$ AC square wave, which is the LCD illumination (ON) level, is generated.

Figure 18-14. 2-Time-Division LCD Display Pattern and Electrode Connections



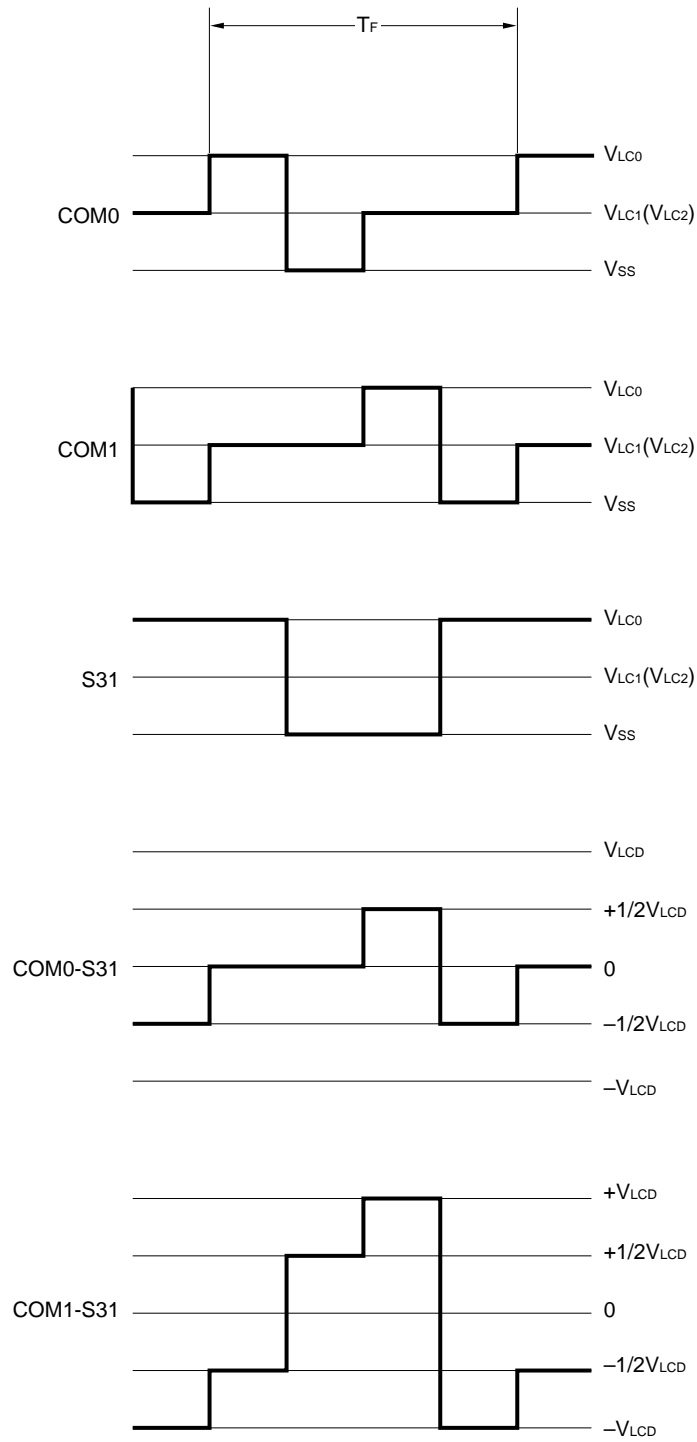
Remark n = 0 to 9

Figure 18-15. 2-Time-Division LCD Panel Connection Example



Remark In bits marked X, 0 or 1 may be stored because this is a 2-time-division display.

Figure 18-16. 2-Time-Division LCD Drive Waveform Examples (1/2 Bias Method)



www.DataSheet4U.com

18.8.3 3-Time-Division Display Example

Figure 18-18 shows the connection of a 3-time-division type 13-digit LCD panel with the display pattern shown in Figure 18-17 with the μ PD78064, 78064Y subseries segment signals (S0 to S38) and common signals (COM0 to COM2). The display example is "123456.7890123," and the display data memory contents (addresses FA59H to FA7FH) correspond to this.

An explanation is given here taking the example of the eighth digit "6." (㉞.). In accordance with the display pattern in Figure 18-17, selection and non-selection voltages must be output to pins S21 through S23 as shown in Table 18-9 at the COM0 to COM2 common signal timings.

Table 18-9. Selection and Non-Selection Voltages (COM0 to COM2)

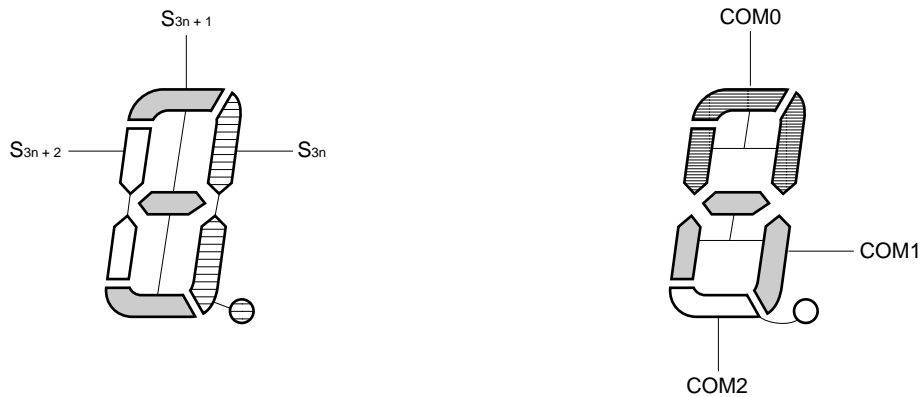
Segment	S21	S22	S23
Common			
COM0	NS	S	S
COM1	S	S	S
COM2	S	S	—

S: Selection, NS: Non-selection

From this, it can be seen that x110 must be prepared in the display data memory (address FA6AH) corresponding to S21.

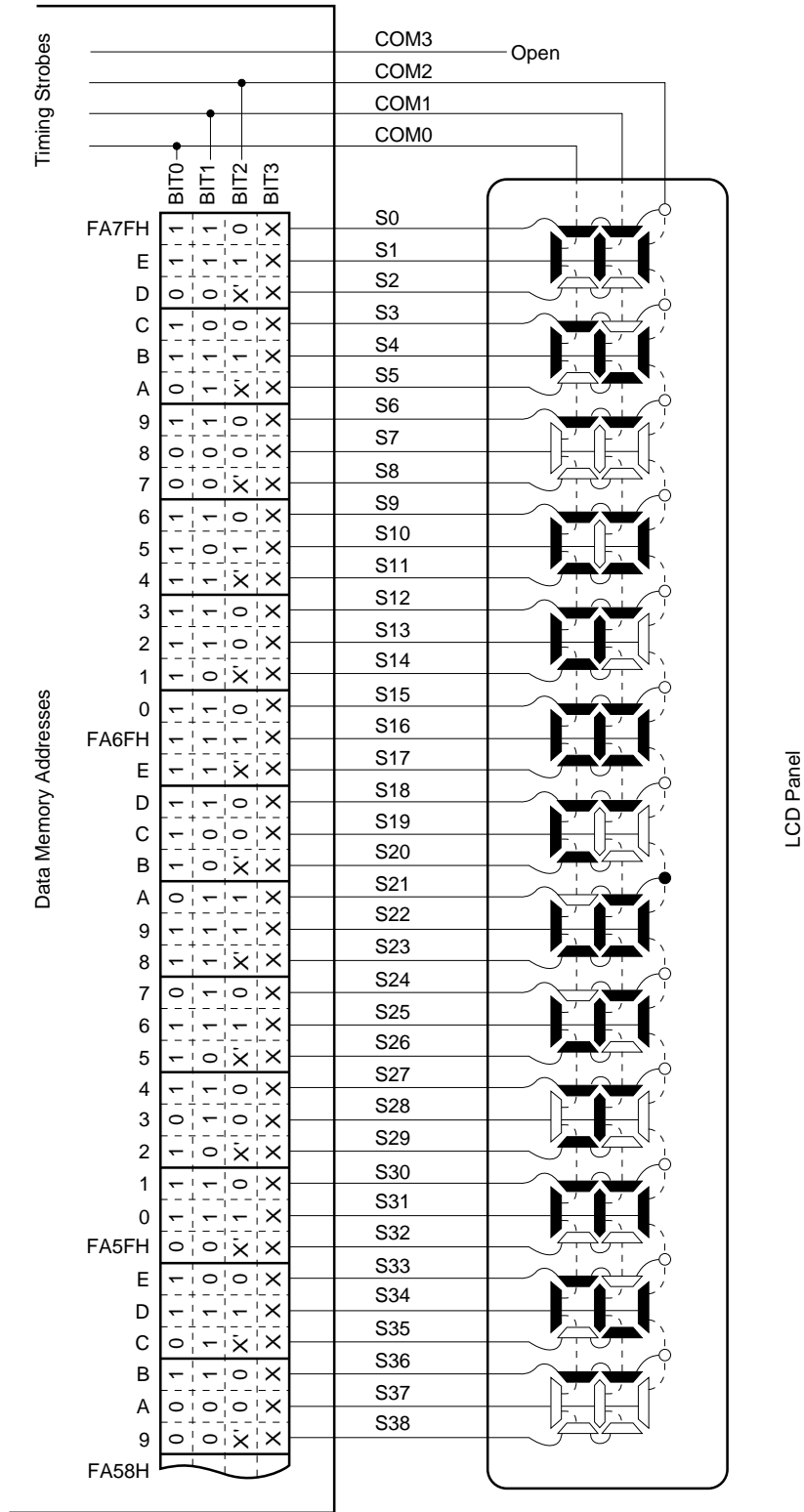
Examples of the LCD drive waveforms between S21 and the common signals are shown in Figure 18-19 (1/2 bias method) and Figure 18-20 (1/3 bias method). When S21 is at the selection voltage at the COM1 selection timing, and S21 is at the selection voltage at the COM2 selection timing, it can be seen that the +V_{LCD}/-V_{LCD} AC square wave, which is the LCD illumination (ON) level, is generated.

Figure 18-17. 3-Time-Division LCD Display Pattern and Electrode Connections



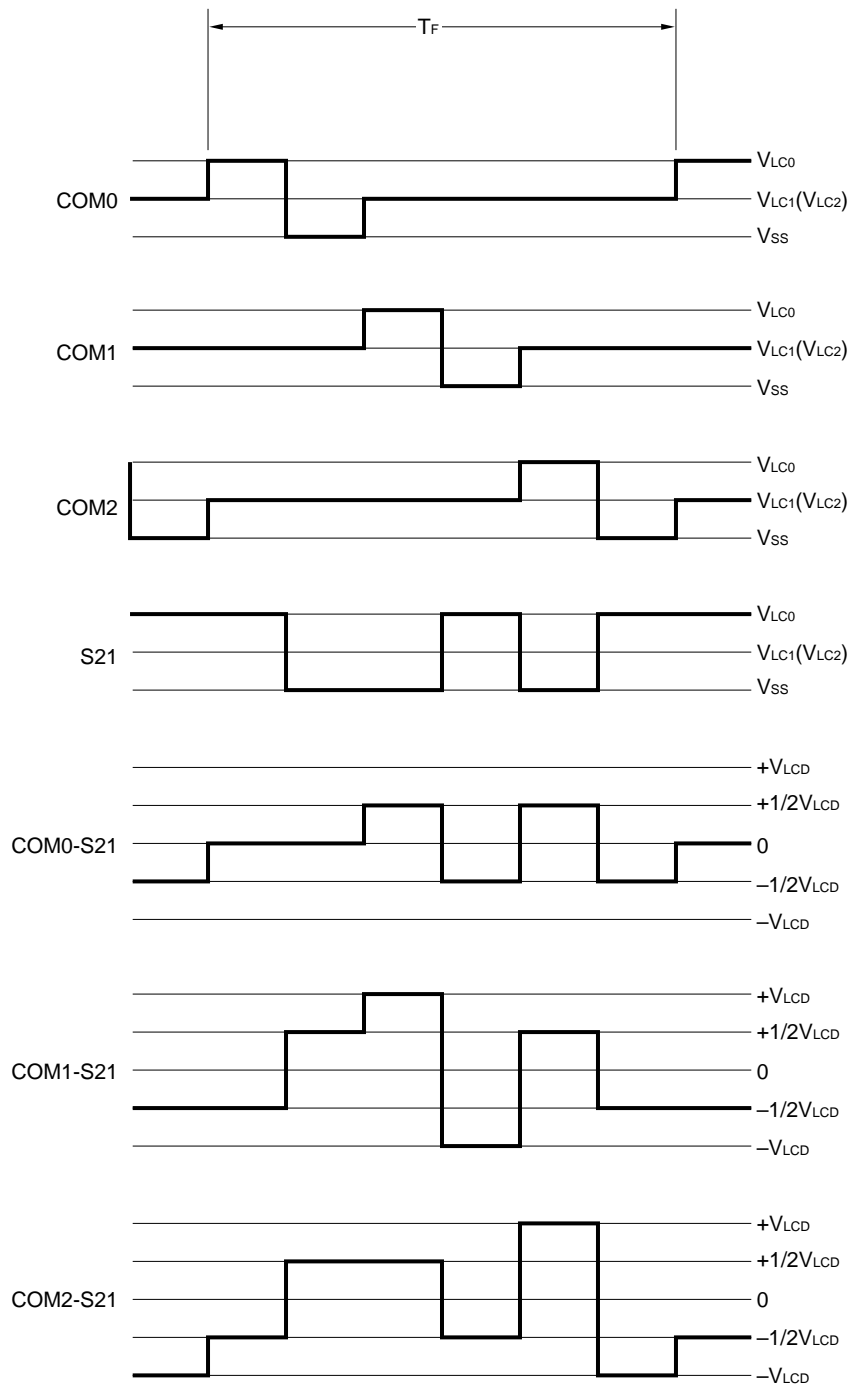
Remark n = 0 to 12

Figure 18-18. 3-Time-Division LCD Panel Connection Example



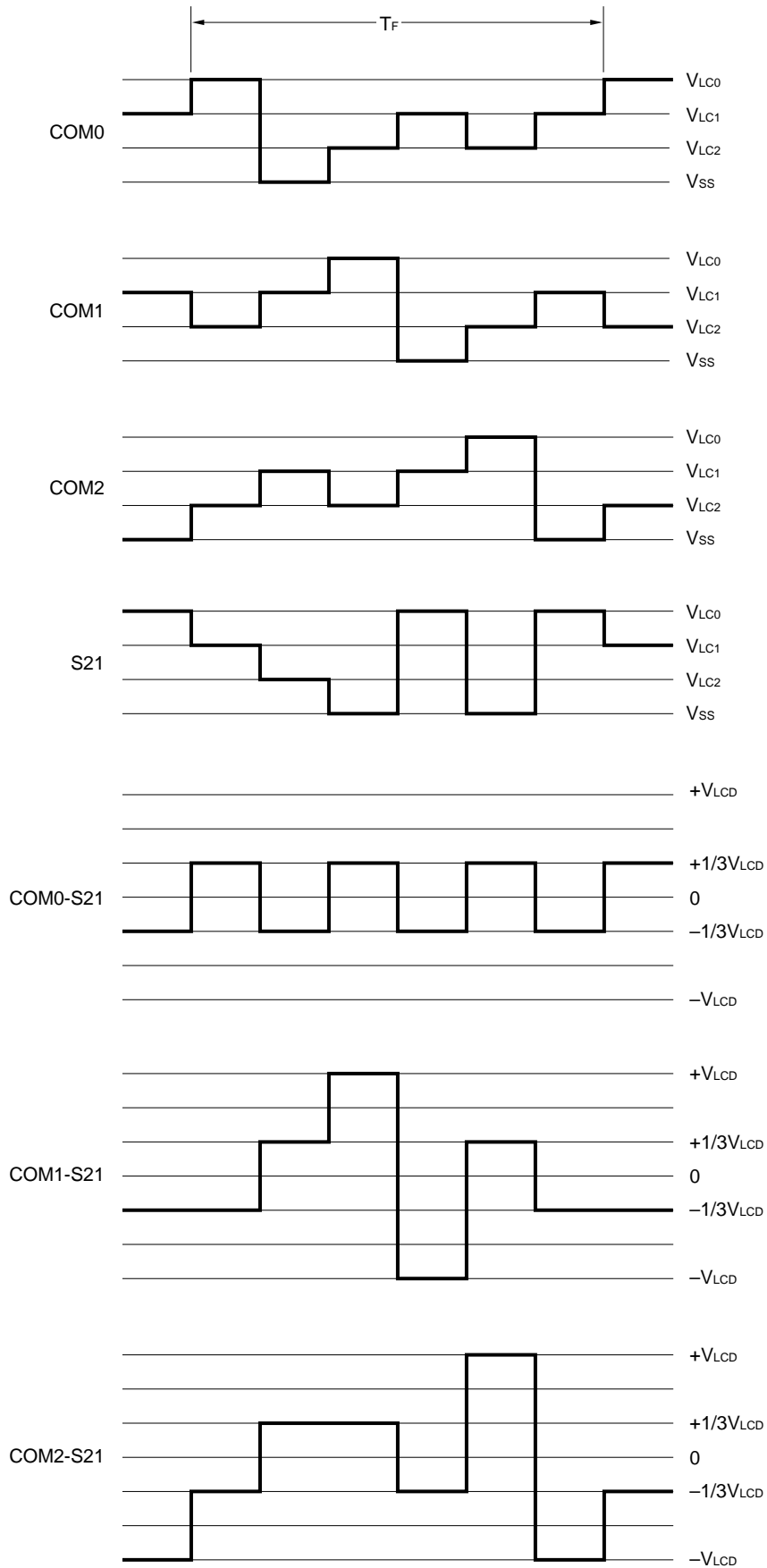
- Remarks**
1. x' : Irrelevant bits because they have no corresponding segment in the LCD panel
 2. x : Irrelevant bits because this is a 3-time-division display

Figure 18-19. 3-Time-Division LCD Drive Waveform Examples (1/2 Bias Method)



www.DataSheet4U.com

Figure 18-20. 3-Time-Division LCD Drive Waveform Examples (1/3 Bias Method)



www.DataSheet4U.com

18.8.4 4-Time-Division Display Example

Figure 18-22 shows the connection of a 4-time-division type 20-digit LCD panel with the display pattern shown in Figure 18-21 with the μ PD78064, 78064Y subseries segment signals (S0 to S39) and common signals (COM0 to COM3). The display example is "123456.78901234567890," and the display data memory contents (addresses FA58H to FA7FH) correspond to this.

An explanation is given here taking the example of the 15th digit "6." (6.). In accordance with the display pattern in Figure 18-21, selection and non-selection voltages must be output to pins S28 and S29 as shown in Table 18-10 at the COM0 to COM3 common signal timings.

Table 18-10. Selection and Non-Selection Voltages (COM0 to COM3)

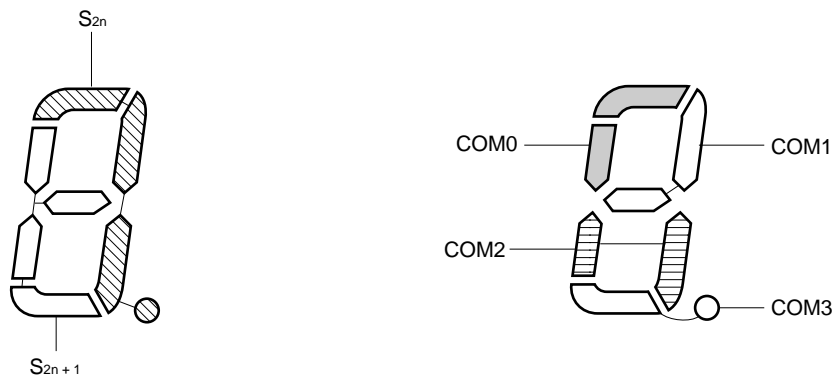
Segment \ Common	S28	S29
COM0	S	S
COM1	NS	S
COM2	S	S
COM3	S	S

S: Selection, NS: Non-selection

From this, it can be seen that 1101 must be prepared in the display data memory (address FA63H) corresponding to S28.

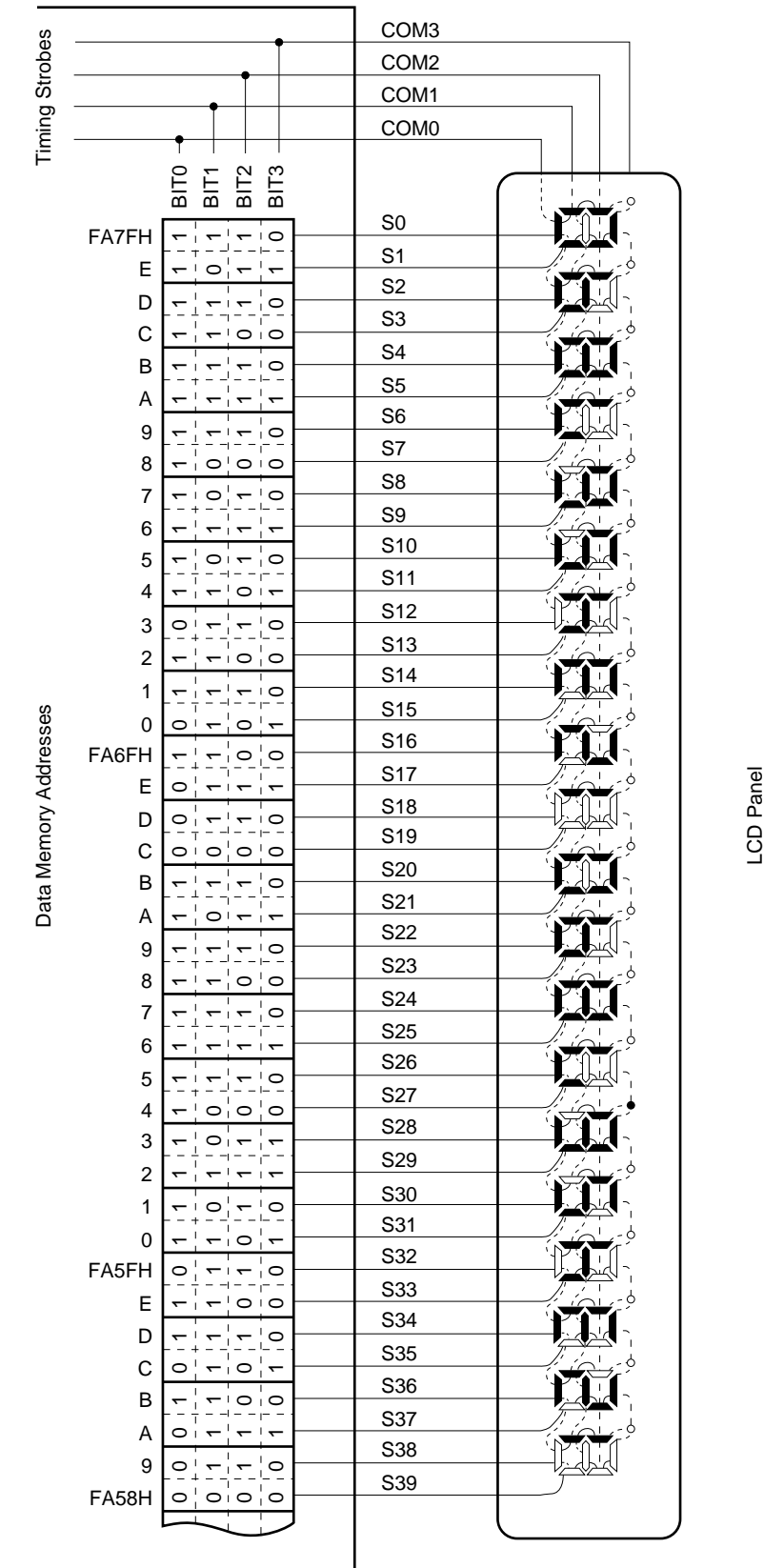
Examples of the LCD drive waveforms between S28 and the COM0 and COM1 signals are shown in Figure 18-23 (for the sake of simplicity, waveforms for COM2 and COM3 have been omitted). When S28 is at the selection voltage at the COM0 selection timing, it can be seen that the $+V_{LCD}/-V_{LCD}$ AC square wave, which is the LCD illumination (ON) level, is generated.

Figure 18-21. 4-Time-Division LCD Display Pattern and Electrode Connections



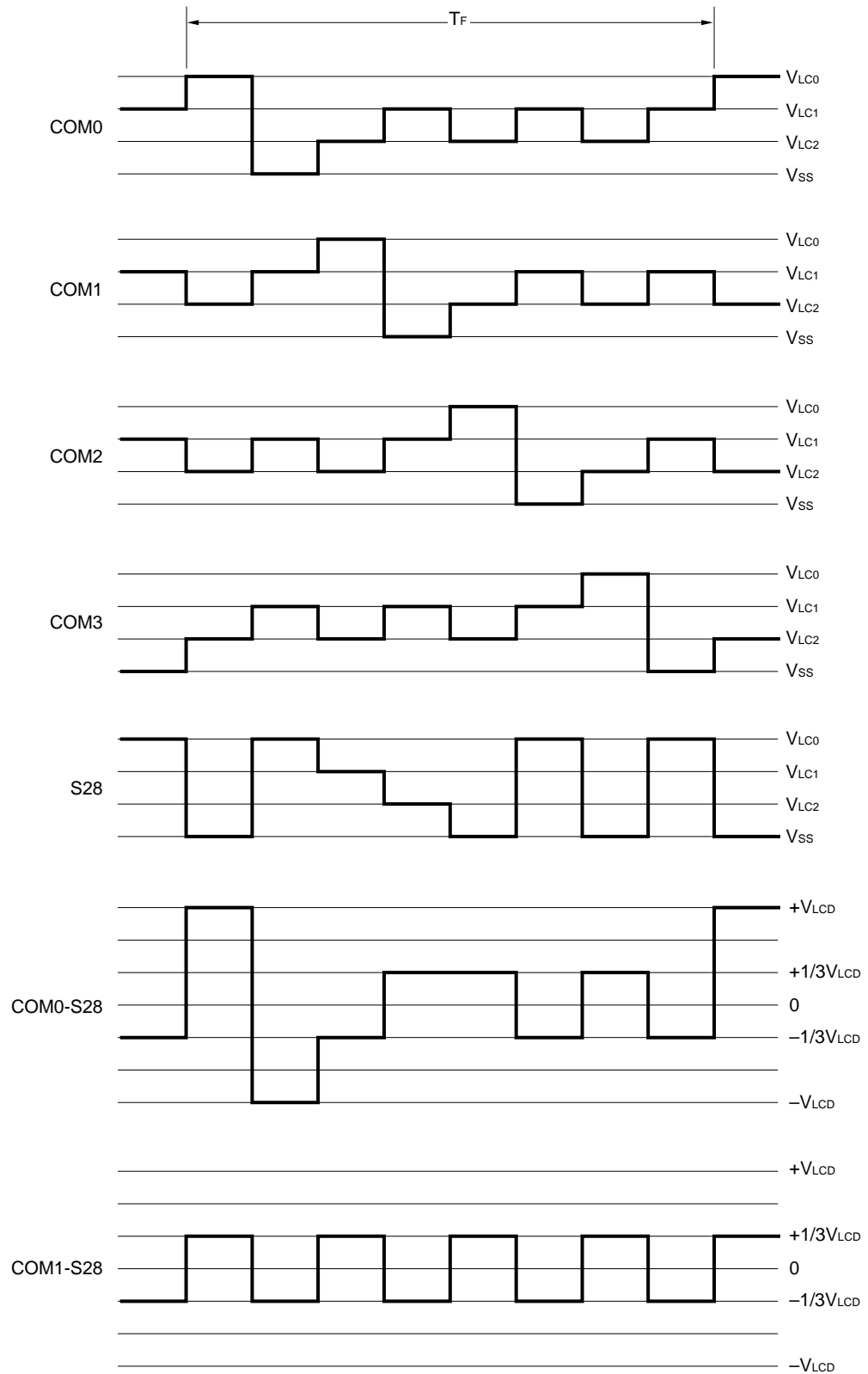
Remark n = 0 to 18

Figure 18-22. 4-Time-Division LCD Panel Connection Example



www.DataSheet4U.com

Figure 18-23. 4-Time-Division LCD Drive Waveform Examples (1/3 Bias Method)



www.DataSheet4U.com

[MEMO]

www.DataSheet4U.com

CHAPTER 19 INTERRUPT AND TEST FUNCTIONS

19.1 Interrupt Function Types

The following three types of interrupt functions are used.

(1) Non-maskable interrupt

This interrupt is acknowledged unconditionally (that is, even in interrupt disabled state). It does not undergo interrupt priority control and is given top priority over all other interrupt requests.

It generates a standby release signal.

One interrupt from the watchdog timer is incorporated as a non-maskable interrupt.

(2) Maskable interrupts

These interrupts undergo mask control. Maskable interrupts can be divided into a high interrupt priority group and a low interrupt priority group by setting the priority specify flag register (PR).

Multiple high priority interrupts can be applied to low priority interrupts. If two or more interrupts with the same priority are simultaneously generated, each interrupt has a predetermined priority (see **Table 19-1**).

A standby release signal is generated.

Six external interrupts and 12 internal interrupts are incorporated as maskable interrupts.

(3) Software interrupt

This is a vectored interrupt to be generated by executing the BRK instruction. It is acknowledged even in interrupt disabled state. The software interrupt does not undergo interrupt priority control.

19.2 Interrupt Sources and Configuration

Twenty non-maskable, maskable, and software interrupts are provided as interrupt causes (see **Table 19-1**).

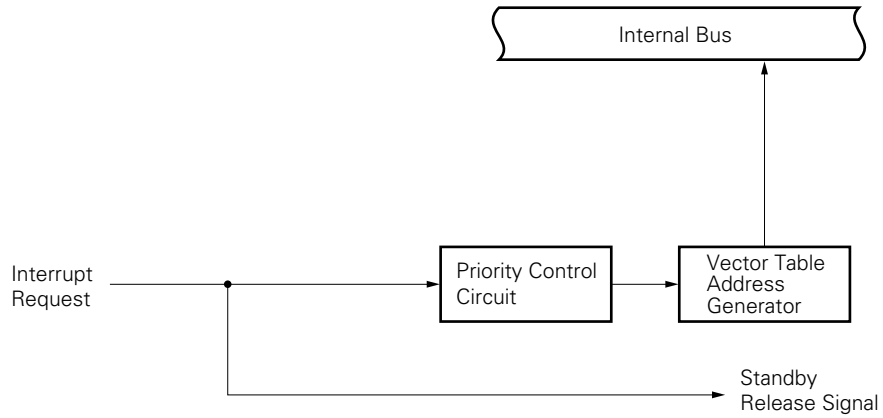
Table 19-1. Interrupt Source List

Maskability	Default(Note1)	Interrupt Source		Internal/ External	Vector Address	Type (Note2)			
	Priority	Name	Trigger						
Non-Maskable	—	INTWDT	Watchdog timer overflow (with watchdog timer mode 1 selected)	Internal	0004H	(A)			
Maskable	0	INTWDT	Watchdog timer overflow (with interval timer mode selected)			External	0006H 0008H 000AH 000CH 000EH 0010H	(B)	
	1	INTP0	Pin input edge detection	Internal	0014H 0018H 001AH 001CH 001EH 0020H 0022H 0024H 0026H 0028H			(C)	
	2	INTP1						(D)	
	3	INTP2							
	4	INTP3							
	5	INTP4							
	6	INTP5							
	7	INTCSI0							End of serial interface channel 0 transfer
	8	INTSER	Serial interface channel 2 UART reception error generation						
	9	INTSR	End of serial interface channel 2 UART reception						
		INTCSI2	End of serial interface channel 2 3-wire transfer						
	10	INTST	End of serial interface channel 2 UART transfer						
	11	INTTM3	Reference time interval signal from watch timer						
	12	INTTM00	Generation of 16-bit timer register, capture/compare register (CR00) match signal						
	13	INTTM01	Generation of 16-bit timer register, capture/compare register (CR01) match signal						
	14	INTTM1	Generation of 8-bit timer/event counter 1 match signal						
	15	INTTM2	Generation of 8 bit timer/event counter 2 match signal						
	16	INTAD	End of A/D converter conversion						
Software	—	BRK	BRK instruction execution	Internal	003EH	(E)			

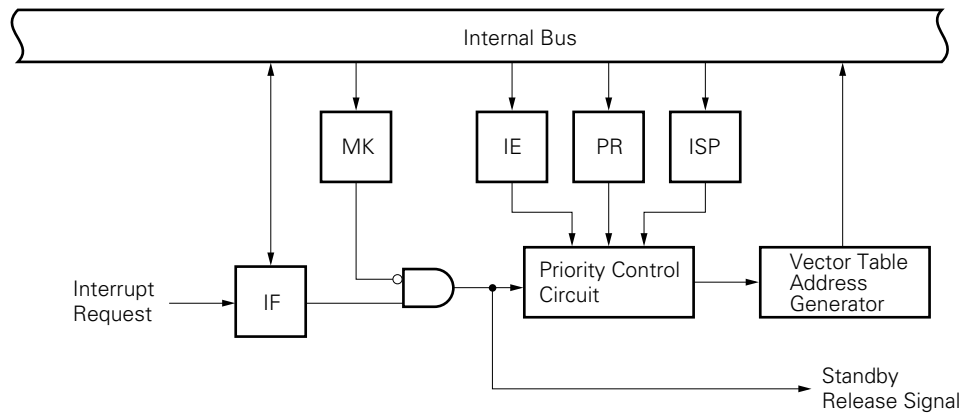
- Notes**
1. Default priorities are intended for two or more simultaneously generated maskable interrupts. 0 is the highest priority and 16 is the lowest priority.
 2. Basic configuration types (A) to (E) correspond to (A) to (E) of Figure 19-1.

Figure 19-1. Basic Configuration of Interrupt Function (1/2)

(A) Internal non-maskable interrupt



(B) Internal maskable interrupt



(C) External maskable interrupt (INTP0)

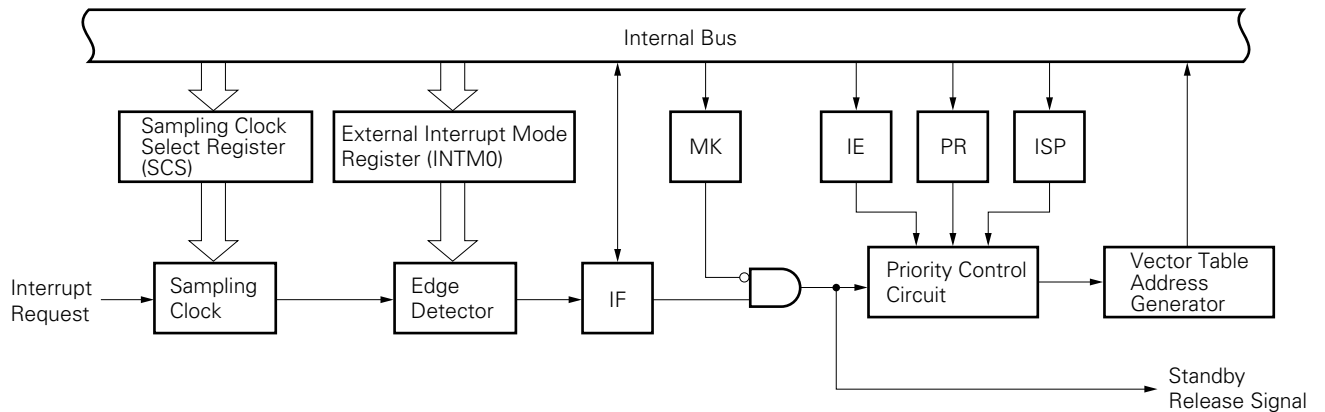
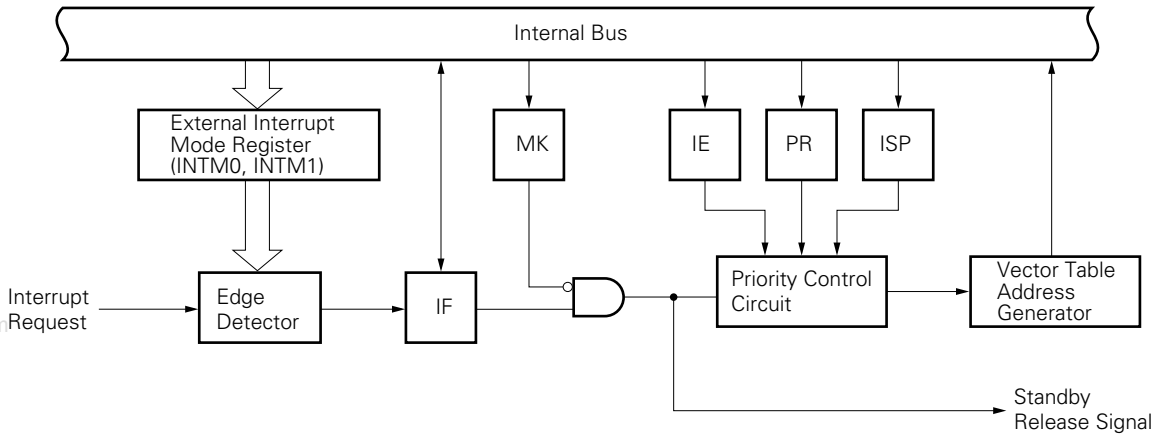
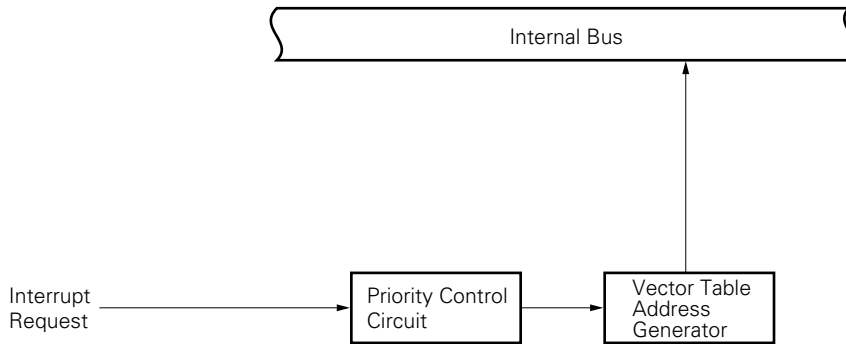


Figure 19-1. Basic Configuration of Interrupt Function (2/2)

(D) External maskable interrupt (except INTP0)



(E) Software interrupt



- IF : Interrupt request flag
- IE : Interrupt enable flag
- ISP : Inservice priority flag
- MK : Interrupt mask flag
- PR : Priority specify flag

19.3 Interrupt Function Control Registers

The following six types of registers are used to control the interrupt functions.

- Interrupt request flag register (IF0L, IF0H, IF1L)
- Interrupt mask flag register (MK0L, MK0H, MK1L)
- Priority specify flag register (PR0L, PR0H, PR1L)
- External interrupt mode register (INTM0, INTM1)
- Sampling clock select register (SCS)
- Program status word (PSW)

Table 19-2 gives a listing of interrupt request flags, interrupt mask flags, and priority specify flags corresponding to interrupt request sources.

Table 19-2. Various Flags Corresponding to Interrupt Request Sources

Interrupt Request Signal Name	Interrupt Request Flag	Interrupt Mask Flag	Priority Specify Flag
INTP0	PIF0	PMK0	PPR0
INTP1	PIF1	PMK1	PPR1
INTP2	PIF2	PMK2	PPR2
INTP3	PIF3	PMK3	PPR3
INTP4	PIF4	PMK4	PPR4
INTP5	PIF5	PMK5	PPR5
INTTM00	TMIF00	TMMK00	TMPR00
INTTM01	TMIF01	TMMK01	TMPR01
INTTM1	TMIF1	TMMK1	TMPR1
INTTM2	TMIF2	TMMK2	TMPR2
INTTM3	TMIF3	TMMK3	TMPR3
INTWDT	TMIF4	TMMK4	TMPR4
INTCSI0	CSIF0	CSIMK0	CSIPR0
INTSR/INTCSI2	SRIF	SRMK	SRPR
INTSER	SERIF	SERMK	SERPR
INTST	STIF	STMK	STPR
INTAD	ADIF	ADMK	ADPR

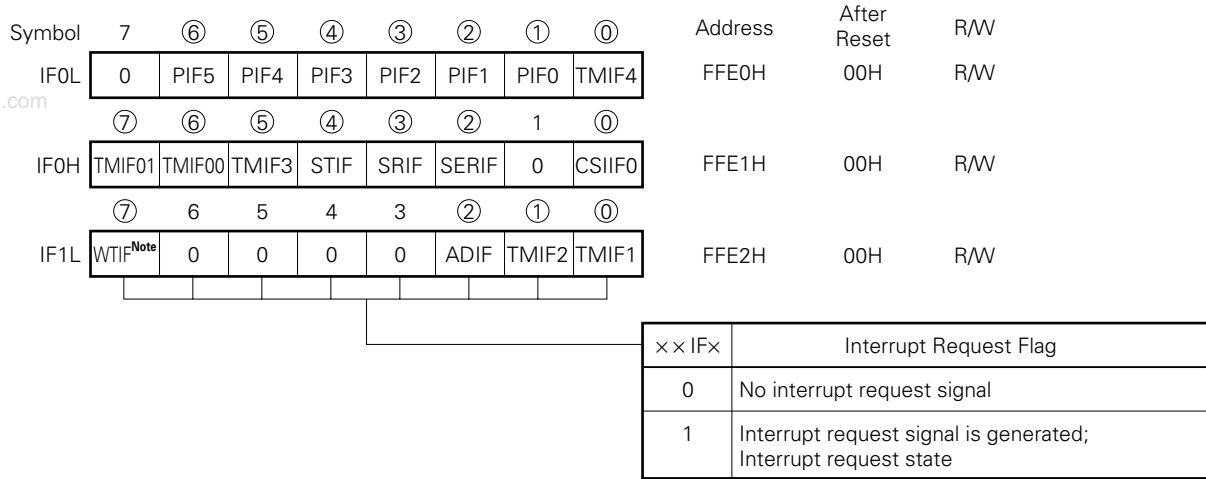
(1) Interrupt request flag registers (IF0L, IF0H, IF1L)

The interrupt request flag is set to 1 when the corresponding interrupt request is generated or an instruction is executed. It is cleared to 0 when an instruction is executed upon acknowledgment of an interrupt request or upon application of $\overline{\text{RESET}}$ input.

IF0L, IF0H, and IF1L are set with a 1-bit or 8-bit memory manipulation instruction. If IF0L and IF0H are used as a 16-bit register IF0 use a 16-bit memory manipulation instruction for the setting.

$\overline{\text{RESET}}$ input sets these registers to 00H.

Figure 19-2. Interrupt Request Flag Register Format



Note WTIF is test input flag. Vectored interrupt is not generated.

- Cautions**
- 1. TMIF4 flag is R/W enabled only when a watchdog timer is used as an interval timer. If a watchdog timer is used in watchdog timer mode 1, set TMIF4 flag to 0.**
 - 2. Because port 0 has a dual function as the external interrupt input, when the output level is changed by specifying the output mode of the port function, an interrupt request flag is set. Therefore, 1 should be set in the interrupt mask flag before using the output mode.**
 - 3. Set always 0 in IF1L bits 3 through 6, IF0L bit 7, and IF0H bit 1.**

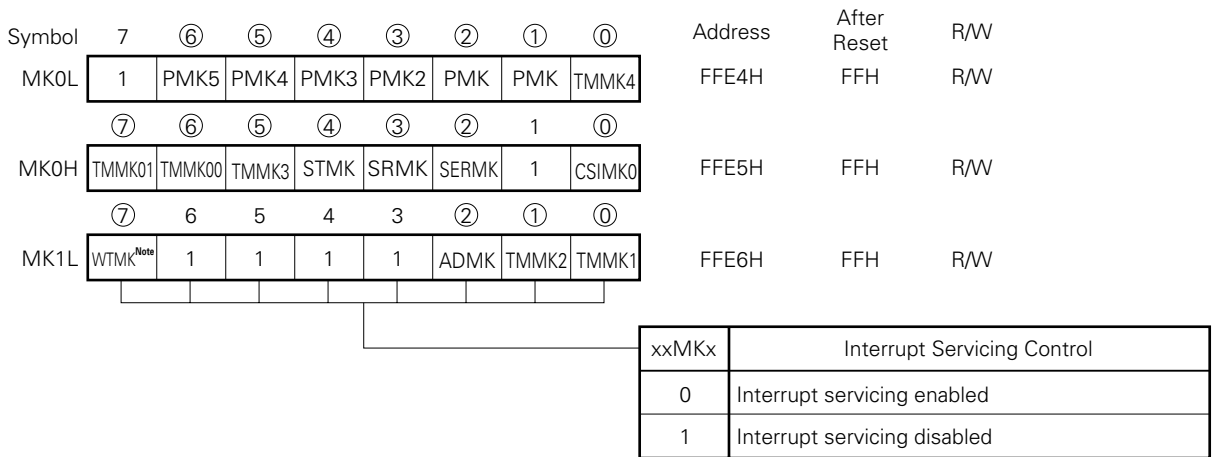
(2) Interrupt mask flag registers (MK0L, MK0H, MK1L)

The interrupt mask flag is used to enable/disable the corresponding maskable interrupt service and to set standby clear enable/disable.

MK0L, MK0H, and MK1L are set with a 1-bit or 8-bit memory manipulation instruction. If MK0L and MK0H are used as a 16-bit register MK0, use a 16-bit memory manipulation instruction for the setting.

RESET input sets these registers to FFH.

Figure 19-3. Interrupt Mask Flag Register Format



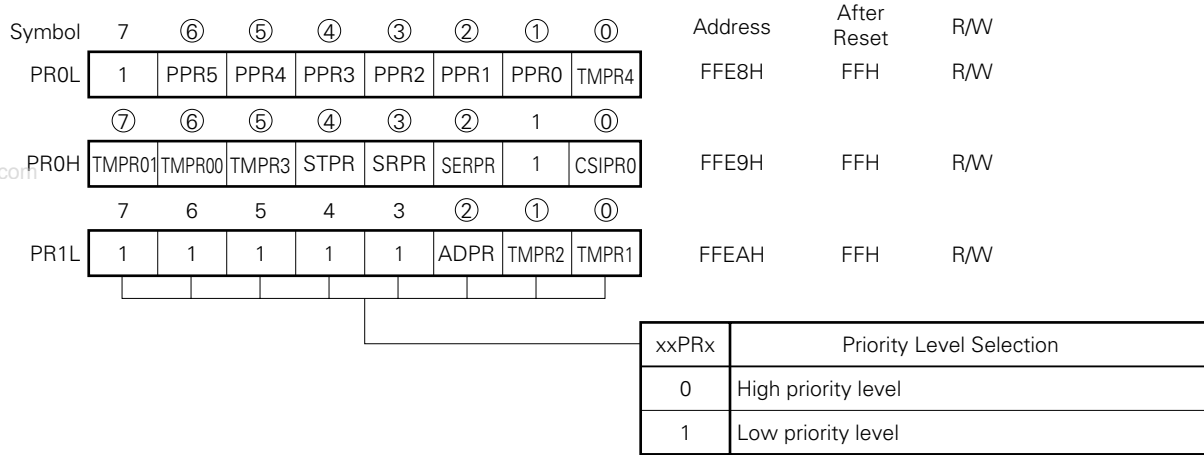
Note WTMK controls standby mode release enable/disable.

- Cautions**
1. If TMMK4 flag is read when a watchdog timer is used in watchdog timer mode 1, MK0 value becomes undefined.
 2. Because port 0 has a dual function as the external interrupt input, when the output level is changed by specifying the output mode of the port function, an interrupt request flag is set. Therefore, 1 should be set in the interrupt mask flag before using the output mode.
 3. Set always 1 in MK1L bits 3 through 6, MK0L bit 7, and MK0H bit 1.

(3) Priority specify flag registers (PR0L, PR0H, and PR1L)

The priority specify flag is used to set the corresponding maskable interrupt priority orders. PR0L, PR0H, and PR1L are set with a 1-bit or 8-bit memory manipulation instruction. If PR0L and PR0H are used as a 16-bit register PR0, use a 16-bit memory manipulation instruction for the setting. RESET input sets these registers to FFH.

Figure 19-4. Priority Specify Flag Register Format



- Cautions**
1. When a watchdog timer is used in watchdog timer mode 1, set 1 in TMPR4 flag.
 2. Set always 1 in PR1L bits 3 through 7, PR0L bit 7, and PR0H bit 1.

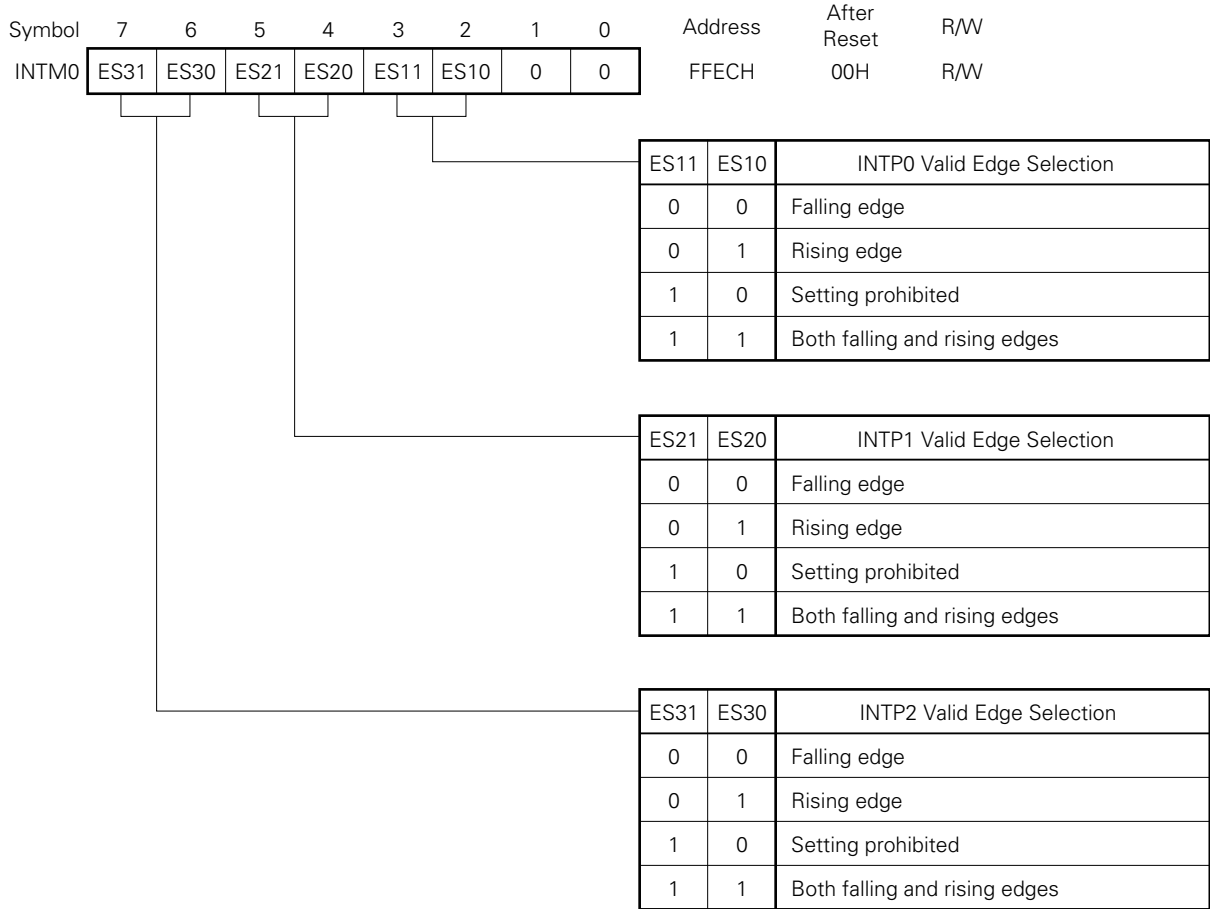
(4) External interrupt mode register (INTM0, INTM1)

These registers set the valid edge for INTP0 to INTP5.

INTM0 and INTM1 are set by 8-bit memory manipulation instructions.

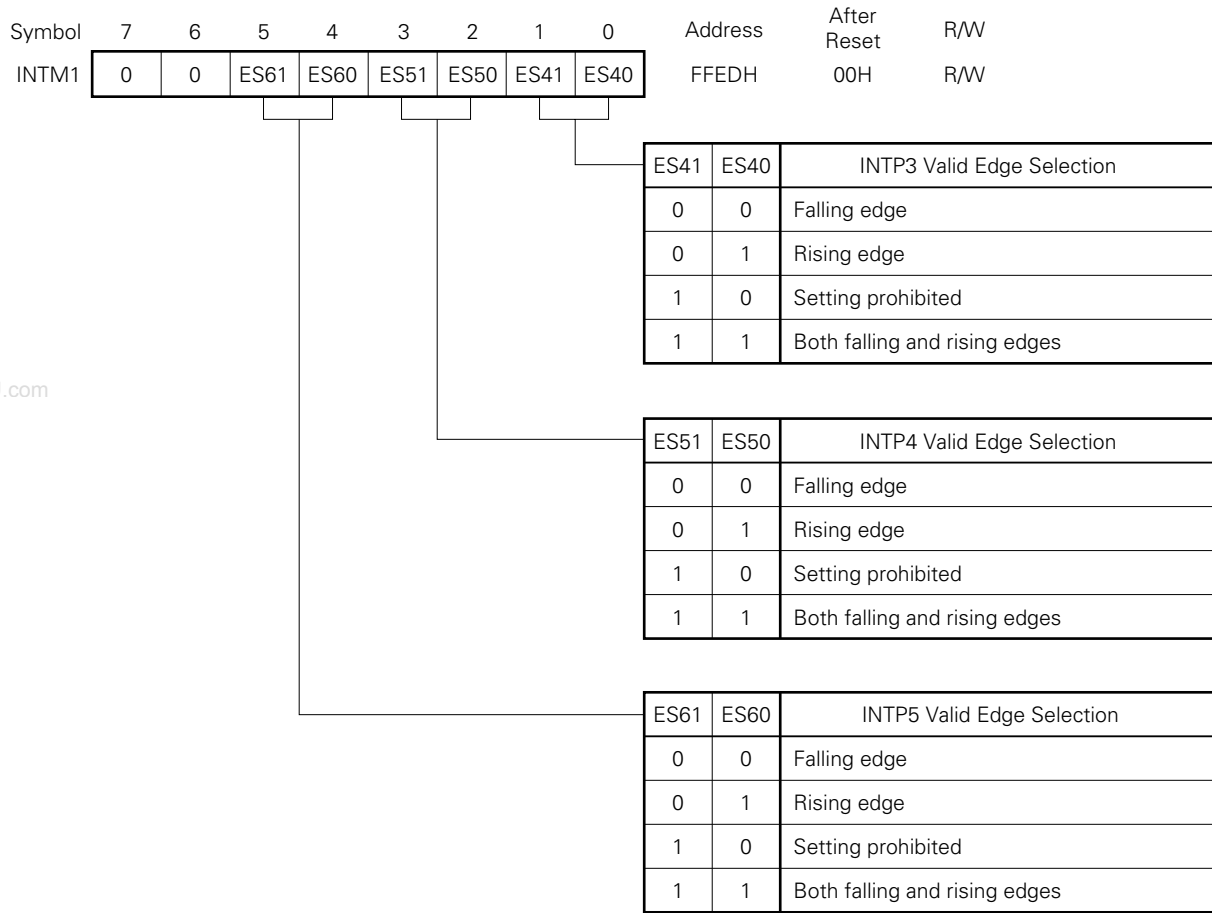
RESET input sets these registers to 00H.

Figure 19-5. External Interrupt Mode Register 0 Format



www.DataSheet4U.com

Figure 19-6. External Interrupt Mode Register 1 Format



www.DataSheet4U.com

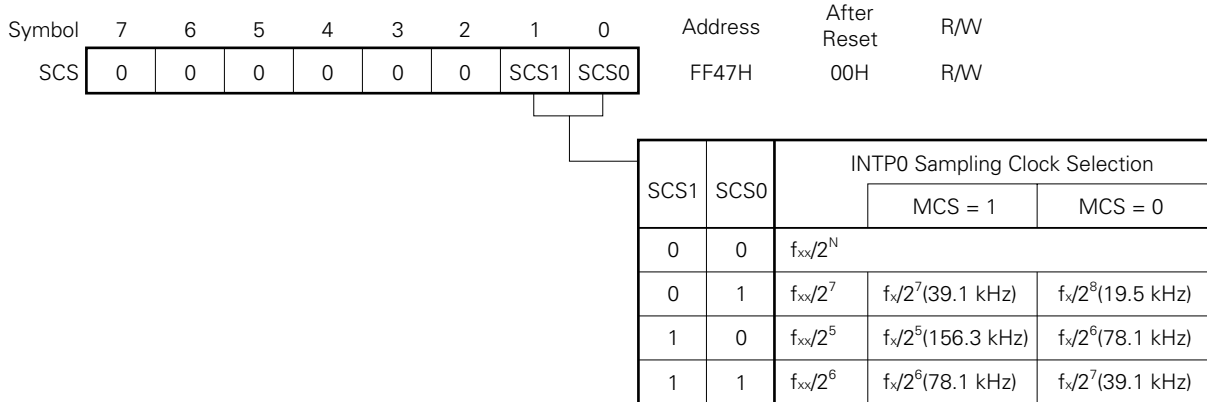
(5) Sampling clock select register (SCS)

This register is used to set the valid edge clock sampling clock to be input to INTP0. When remote controlled data reception is carried out using INTP0, digital noise is removed with sampling clocks.

SCS is set with an 8-bit memory manipulation instruction.

$\overline{\text{RESET}}$ input sets SCS to 00H.

Figure 19-7. Sampling Clock Select Register Format



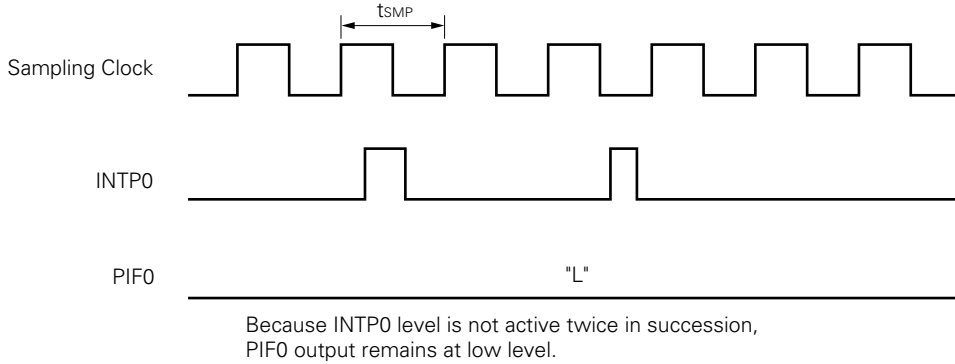
Caution $f_{xx}/2^N$ is a clock to be supplied to the CPU and $f_{xx}/2^5$, $f_{xx}/2^6$ and $f_{xx}/2^7$ are clocks to be supplied to the peripheral hardware. $f_{xx}/2^N$ stops in the HALT mode.

- Remarks**
1. N : Value (N=0 to 4) at bits 0 to 2 (PCC0 to PCC2) of processor clock control register
 2. f_{xx} : Main system clock frequency (f_x or $f_x/2$)
 3. f_x : Main system clock oscillation frequency
 4. MCS : Oscillation mode selection register bit 0
 5. Values in parentheses when operated with $f_x = 5.0$ MHz.

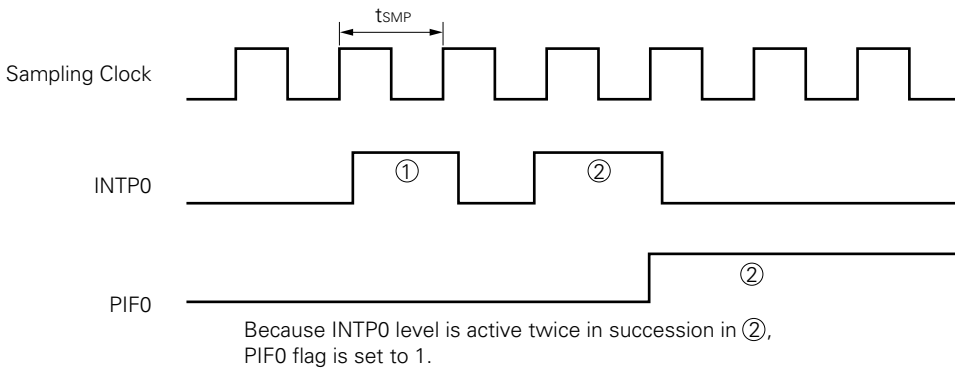
When the INTPO input level is active twice in succession, the noise remover sets PIF0 flag to 1.

Figure 19-8. Noise Remover Input/Output Timing (during rising edge detection)

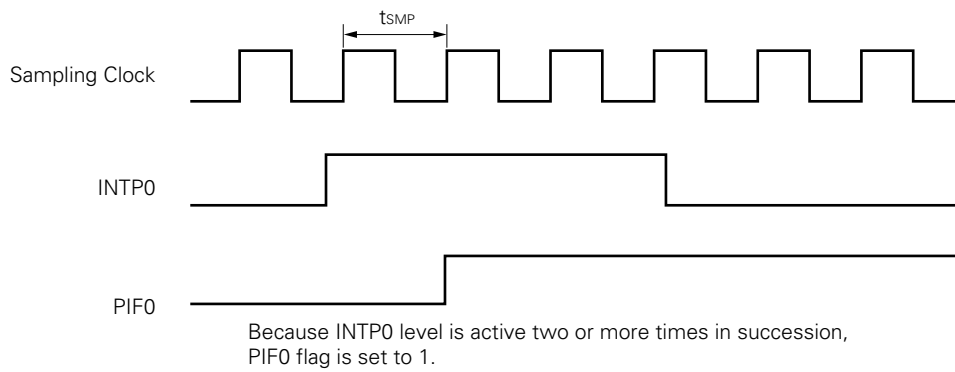
(a) When input is less than the sampling cycle (t_{SMP})



(b) When input is equal to or twice the sampling cycle (t_{SMP})



(c) When input is twice or more than the cycle frequency (t_{SMP})



(6) Program status word (PSW)

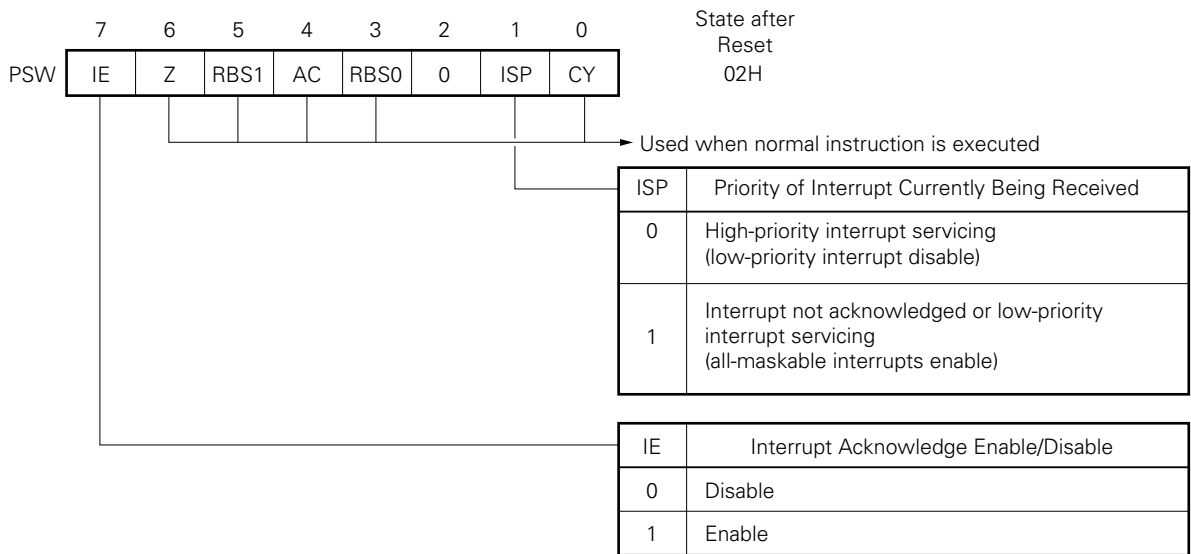
The program status word is a register to hold the instruction execution result and the current status for interrupt request. The IE flag to set maskable interrupt enable/disable and the ISP flag to control multiple interrupt servicing are mapped.

Besides 8-bit unit read/write, this register can carry out operations with a bit manipulation instruction and dedicated instructions (EI and DI). When a vectored interrupt is acknowledged or the BRK instruction is executed, PSW is automatically saved into a stack and the IE flag is reset to 0. If a maskable interrupt is acknowledged contents of the priority specify flag of the acknowledged interrupt are transferred to the ISP flag. The acknowledged interrupt is also saved into the stack with the PUSH PSW instruction. It is reset from the stack with the RETI, RETB, and POP PSW instructions.

$\overline{\text{RESET}}$ input sets PSW to 02H.

www.DataSheet4U.com

Figure 19-9. Program Status Word Format



19.4 Interrupt Servicing Operations

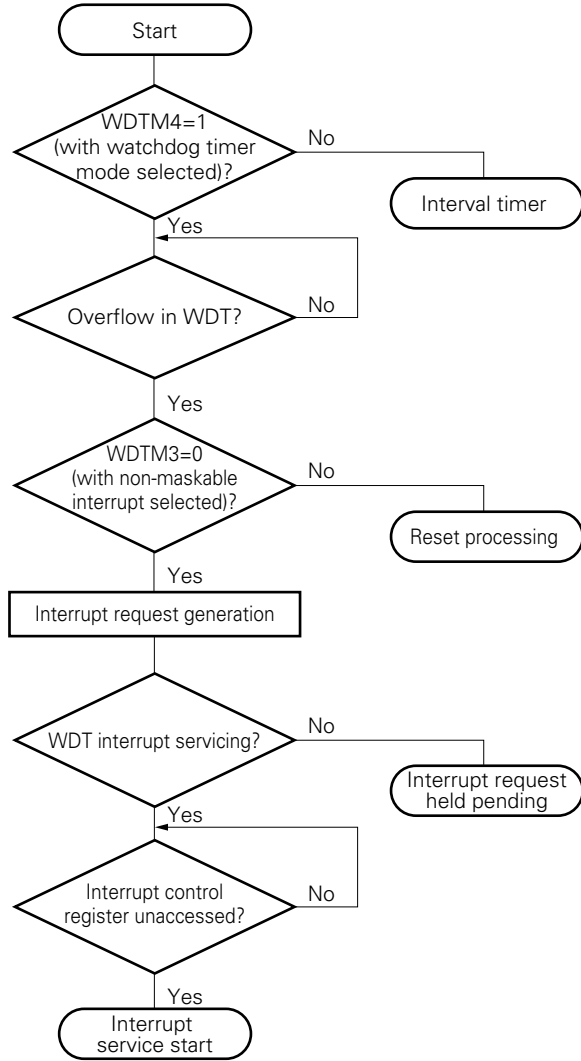
19.4.1 Non-maskable interrupt acknowledge operation

A non-maskable interrupt is unconditionally acknowledged even if in an interrupt acknowledge disable state. It does not undergo interrupt priority control and has highest priority over all other interrupts.

If a non-maskable interrupt request is acknowledged, the acknowledged interrupt is saved in the stacks, PSW and PC, in that order, the IE and ISP flags are reset to 0, and the vector table contents are loaded into PC and branched.

A new non-maskable interrupt request generated during execution of a non-maskable interrupt servicing program is acknowledged after the current execution of the non-maskable interrupt servicing program is terminated (following RETI instruction execution) and one main routine instruction is executed. If a new non-maskable interrupt request is generated twice or more during non-maskable interrupt service program execution, only one non-maskable interrupt request is acknowledged after termination of the non-maskable interrupt service program execution.

Figure 19-10. Non-Maskable Interrupt Acknowledge Flowchart



WDTM : Watchdog timer mode register
WDT : Watchdog timer

Figure 19-11. Non-Maskable Interrupt Acknowledge Timing

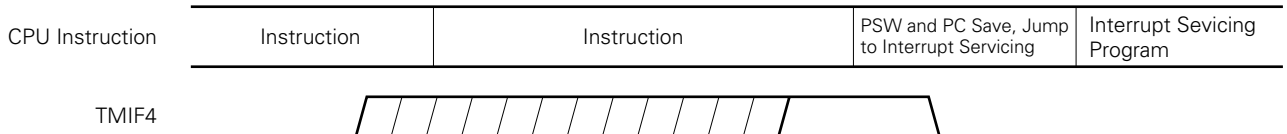
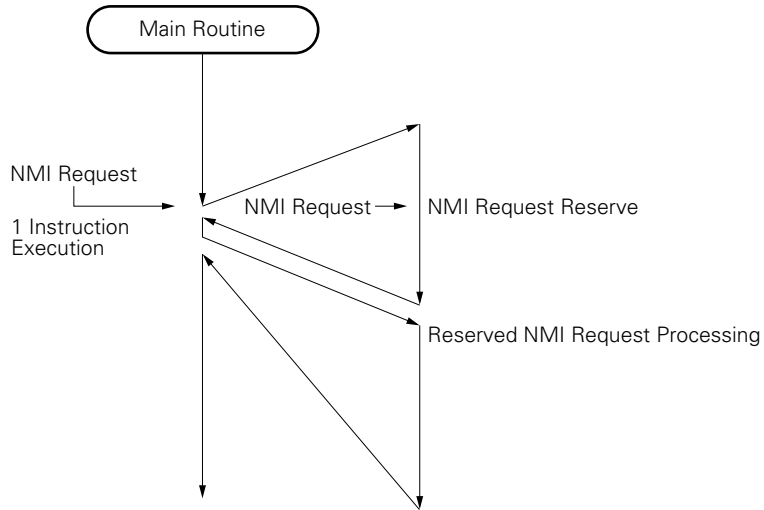
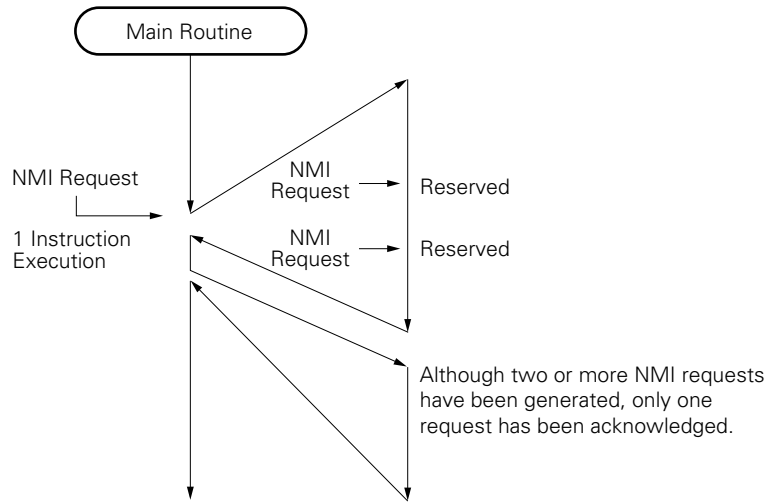


Figure 19-12. Non-Maskable Interrupt Request Acknowledge Operation

- (a) If a new non-maskable interrupt request is generated during non-maskable interrupt servicing program execution



- (b) If two non-maskable interrupt requests are generated during non-maskable interrupt servicing program execution



www.DataSheet4U.com

19.4.2 Maskable interrupt acknowledge operation

A maskable interrupt becomes acknowledgeable when an interrupt request flag is set to 1 and the interrupt MK flag is cleared to 0. A vectored interrupt is acknowledged in an interrupt enable state (with IE flag set to 1). However, a low-priority interrupt is not acknowledged during high-priority interrupt service (with ISP flag reset to 0).

Wait times maskable interrupt request generation to interrupt servicing are as follows.

Table 19-3. Times from Maskable Interrupt Request Generation to Interrupt Service

	Minimum Time	Maximum Time Note
When xxPRx = 0	7 clock cycles	32 clock cycles
When xxPRx = 1	8 clock cycles	33 clock cycles

Note If an interrupt request is generated just before a divide instruction, the wait time is maximized.

Remark 1 clock cycle = 1/CPU clock frequency (f_{CPU})

If two or more maskable interrupt requests are generated simultaneously, the request specified for higher priority with the priority specify flag is acknowledged first. Two or more requests specified for the same priority, the default priorities apply.

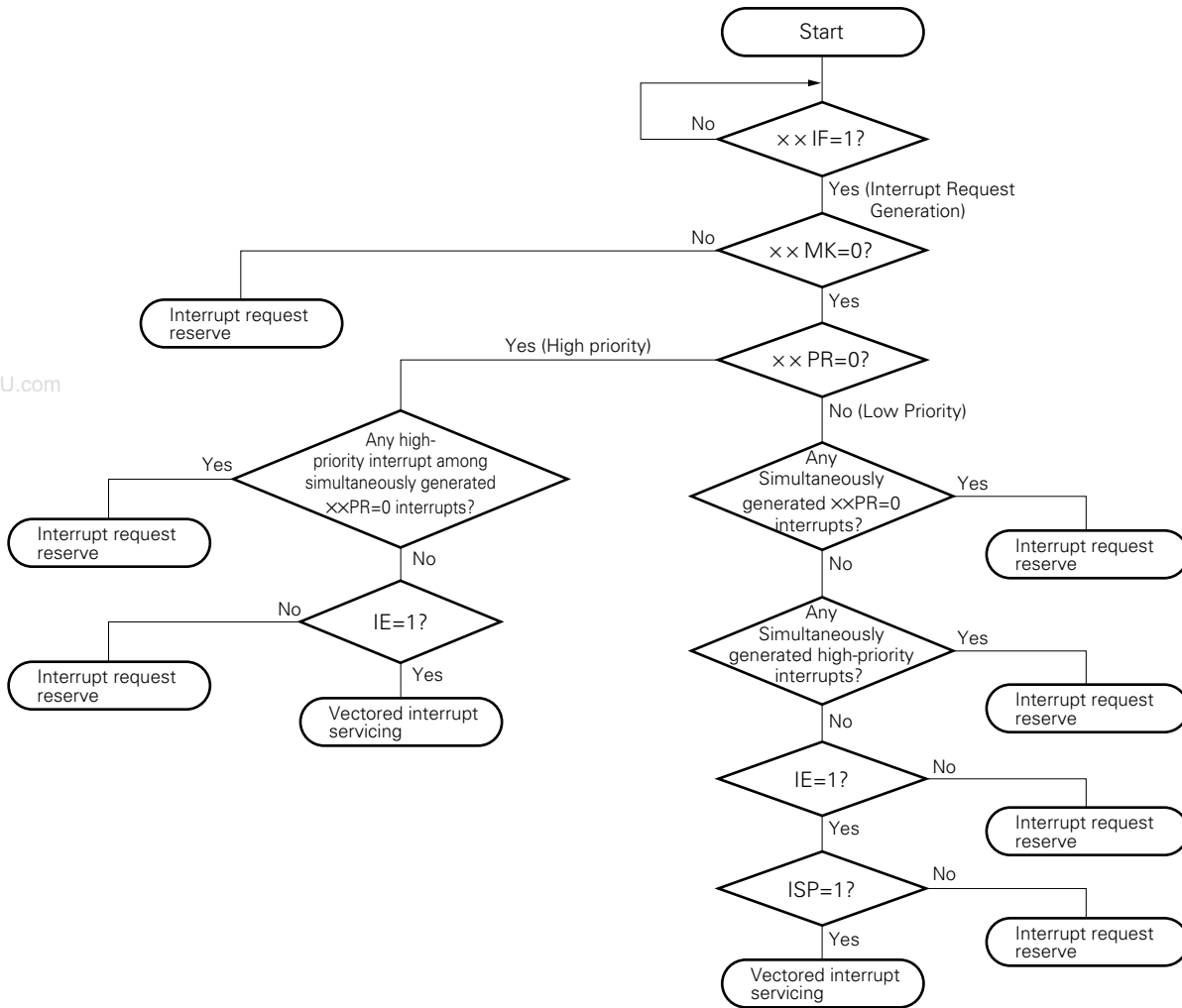
Any reserved interrupts are acknowledged when they become acknowledgeable.

Figure 19-13 shows interrupt acknowledge algorithms.

If a maskable interrupt request is acknowledged, the acknowledged interrupt is saved in the stacks, PSW and PC, in that order, the IE flag is reset to 0, and the acknowledged interrupt priority specify flag contents are transferred to the ISP flag. Further, the vector table data determined for each interrupt request is loaded into PC and branched.

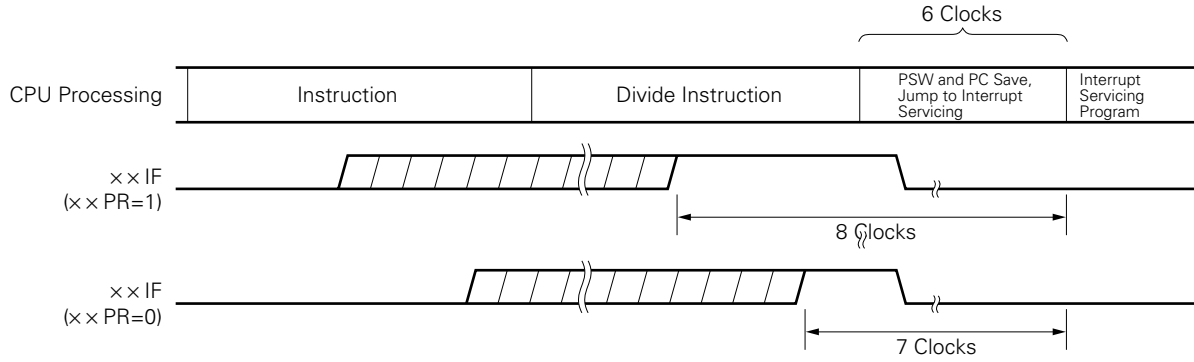
Return from the interrupt is possible with the RETI instruction.

Figure 19-13. Interrupt Acknowledge Processing Algorithm



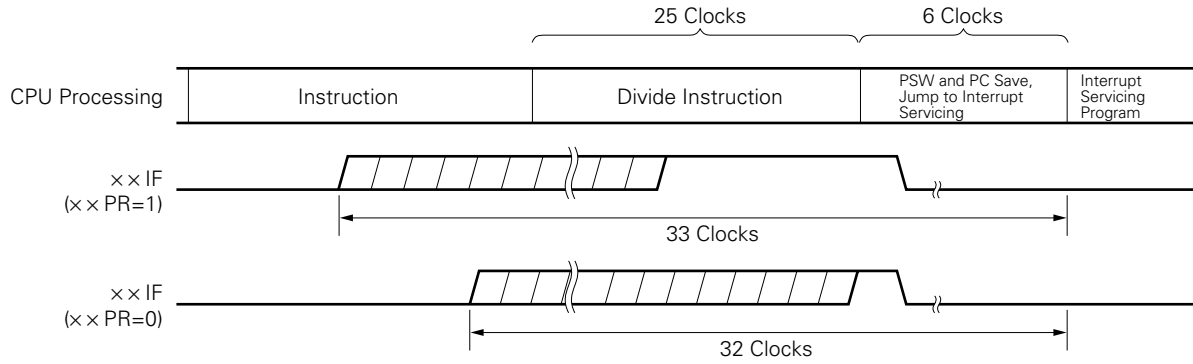
www.DataSheet4U.com

Figure 19-14. Interrupt Acknowledge Timing (Minimum Time)



Remark 1 clock cycle = 1/CPU clock frequency (f_{CPU})

Figure 19-15. Interrupt Acknowledge Timing (Maximum Time)



Remark 1 clock cycle = 1/CPU clock frequency (f_{CPU})

19.4.3 Software interrupt acknowledge operation

A software interrupt is acknowledged by BRK instruction execution. Software interrupt cannot be disabled.

If a software interrupt is acknowledged, it is saved in the stacks, PSW and PC, in that order, the IE flag is reset to 0 and the contents of the vector tables (003EH and 003FH) are loaded into PC and branched.

Return from the software interrupt is possible with the RETB instruction.

Caution Do not use the RETI instruction for returning from the software interrupt.

19.4.4 Multiple interrupt servicing

Multiple interrupts, in which another interrupt is acknowledged during execution of an interrupt, can be controlled by priorities.

Two types of priority control are available; control in the order of default priority and programmable priority control by setting the priority specify flag registers (PR0L, PR0H and PR1L). In the former, if two or more interrupts are generated simultaneously, interrupt servicing is carried out in accordance with the priority (default priority) preassigned to each interrupt request (see **Table 19-1**). In the latter, interrupt requests are divided into a high-priority group and a low-priority group by setting the bits corresponding to PR0L, PR0H, and PR1L. The following are the interrupt requests enabled for multiple interrupts.

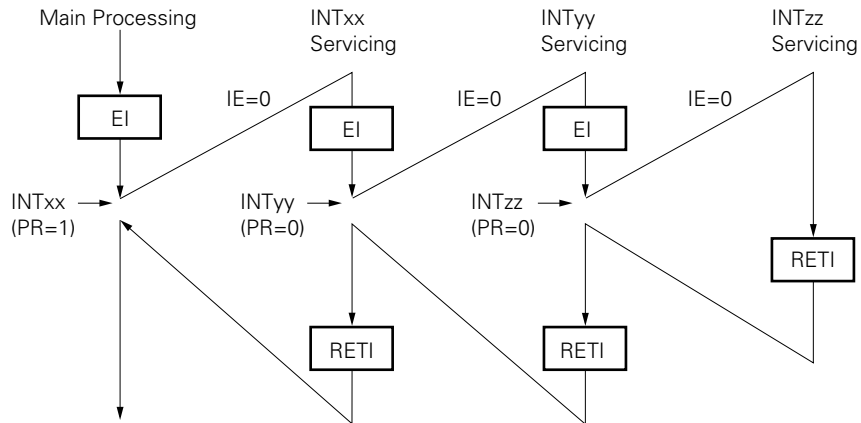
Table 19-4. Interrupt Request Enabled for Multiple Interrupt during Interrupt Servicing

Multiple Interrupt Request Interrupt being Acknowledged		Non-maskable Interrupt Request	Maskable Interrupt Request			
			PR=0		PR=1	
			IE=1	IE=0	IE=1	IE=0
Non-maskable interrupt servicing		D	D	D	D	D
Maskable interrupt servicing	ISP=0	E	E	D	D	D
	ISP=1	E	E	D	E	D
Software interrupt servicing		E	E	D	E	D

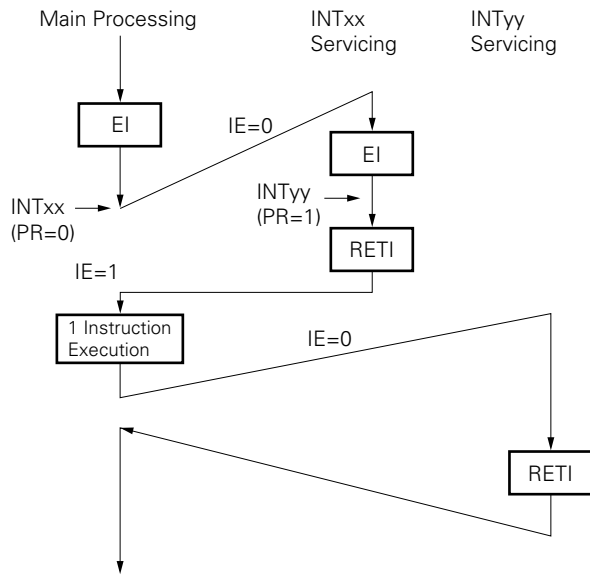
- Remarks**
- E : Multiple interrupt enable
 - D : Multiple interrupt disable
 - ISP and IE are the flags contained in PSW
 - ISP=0 : An interrupt with higher priority is being serviced
 - ISP=1 : An interrupt is not accepted or an interrupt with lower priority is being serviced
 - IE=0 : Interrupt acknowledge is disabled
 - IE=1 : Interrupt acknowledge is enabled
 - PR is a flag contained in PR0L, PR0H, PR1L
 - PR=0 : Higher priority level
 - PR=1 : Lower priority level

Figure 19-16. Multiple Interrupt Example

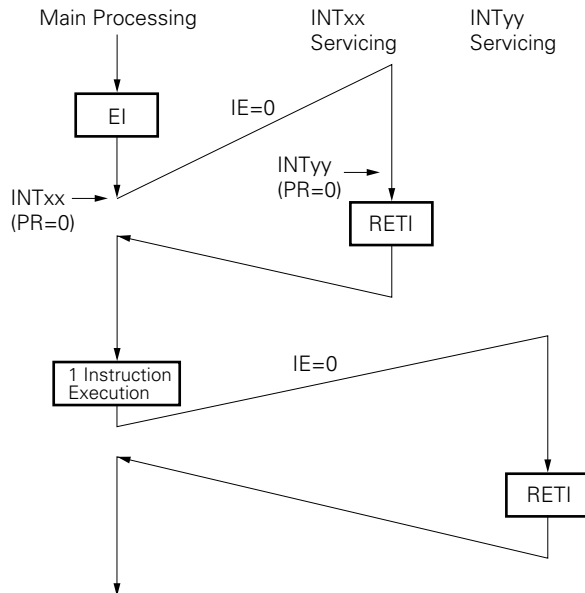
Example 1



Example 2



Example 3



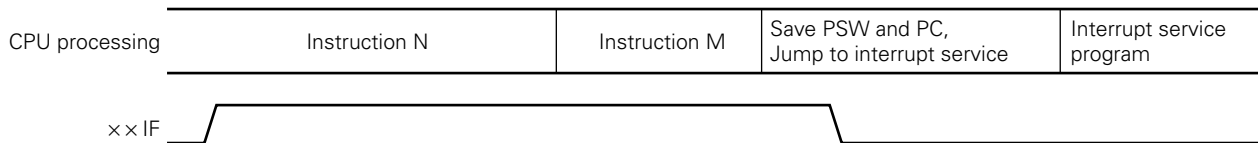
19.4.5 Interrupt reserve

Interrupt acknowledge is temporarily reserved between any of the following instructions and the next instruction to be executed.

- MOV PSW, #byte
- MOV A, PSW
- MOV PSW, A
- MOV1 PSW.bit, CY
- MOV1 CY, PSW.bit
- AND1 CY, PSW.bit
- OR1 CY, PSW.bit
- XOR1 CY, PSW.bit
- SET1 PSW.bit
- CLR1 PSW.bit
- RETB
- RETI
- PUSH PSW
- POP PSW
- BT PSW.bit, \$addr16
- BF PSW.bit, \$addr16
- BTCLR PSW.bit, \$addr16
- EI
- DI
- Manipulate instructions for IF0L, IF0H, IF1L, MK0L, MK0H, MK1L, PR0L, PR0H, PR1L, INTM0, INTM1 registers

Caution Because the IE flag is cleared to 0 by the software interrupt (by executing the BRK instruction), interrupts are not acknowledged even when a maskable interrupt request is issued during the execution of the BRK instruction. However, non-maskable interrupt requests are acknowledged.

Figure 19-17. Interrupt Request Hold



- Remarks**
1. Instruction N: Instruction that holds interrupts requests
 2. Instruction M: Instructions other than interrupt request pending instruction
 3. The xxPR values do not affect the operation of xxIF.

19.5 Test Functions

Vector processing is not performed, but the test input flag is set to 1. In this function, the standby release signal is generated.

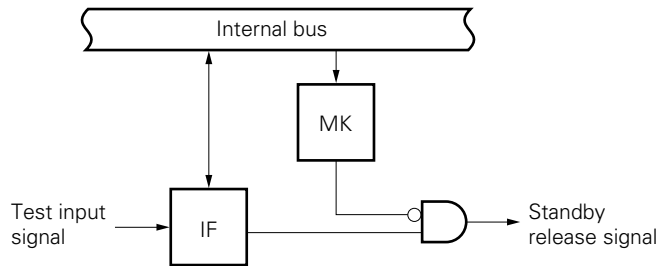
There are two test input factors as shown in Table 19-5. The basic configuration is shown in Figure 19-18.

Table 19-5. Test Input Factors

Test Input Factors		Internal/ External
Name	Trigger	
INTWT	Watch timer overflow	Internal
INTPT11	Falling edge detection at port 11	External

www.DataSheet4U.com

Figure 19-18. Basic Configuration of Test Function



IF: test input flag
MK: test mask flag

19.5.1 Registers controlling the test function

The test function is controlled by the following three registers.

- Interrupt request flag register 1L (IF1L)
- Interrupt mask flag register 1L (MK1L)
- Key return mode register (KRM)

The names of the test input flags and test mask flags corresponding to the test input signals are listed in Table 19-6.

Table 19-6. Flags Corresponding to Test Input Signals

Test input signal name	Test input flag	Test mask flag
INTWT	WTIF	WTMK
INTPT11	KRIF	KRMK

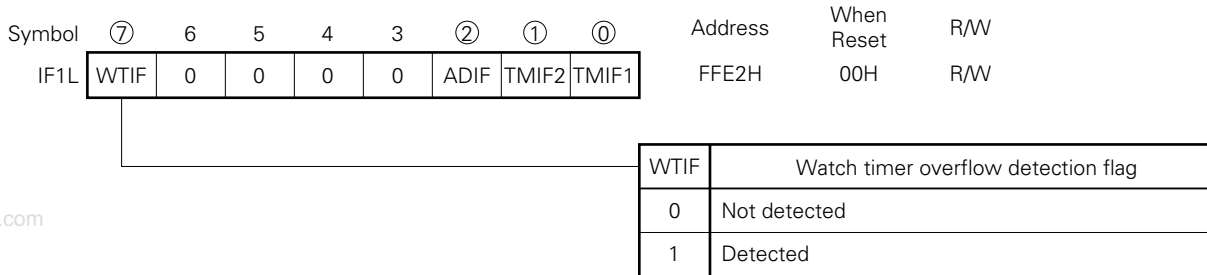
(1) Interrupt request flag register 1L (IF1L)

It indicates whether a watch timer overflow is detected or not.

It is set by a 1-bit memory manipulation instruction and 8-bit memory manipulation instruction.

It is set to 00H by the RESET signal input.

Figure 19-19. Format of Interrupt Request Flag Register 1L



www.DataSheet4U.com

Caution Be sure to set bits 3 through 6 to 0.

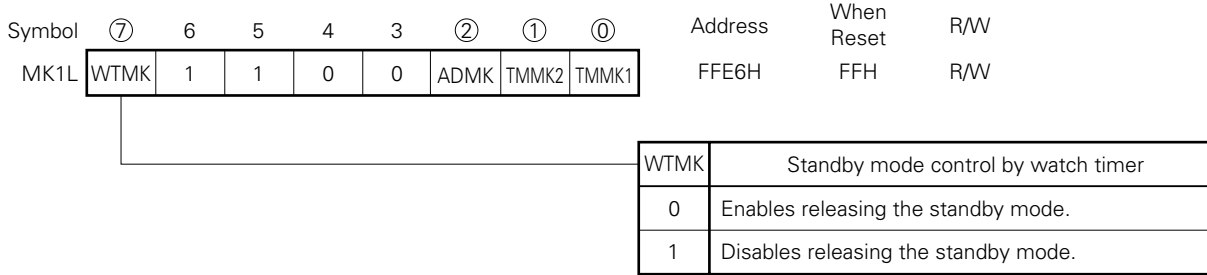
(2) Interrupt mask flag register 1L (MK1L)

It is used to set the standby mode enable/disable at the time the standby mode is released by the watch timer.

It is set by a 1-bit memory manipulation instruction and 8-bit memory manipulation instruction.

It is set to FFH by the RESET signal input.

Figure 19-20. Format of Interrupt Mask Flag Register 1L



Caution Be sure to set bits 3 through 6 to 1.

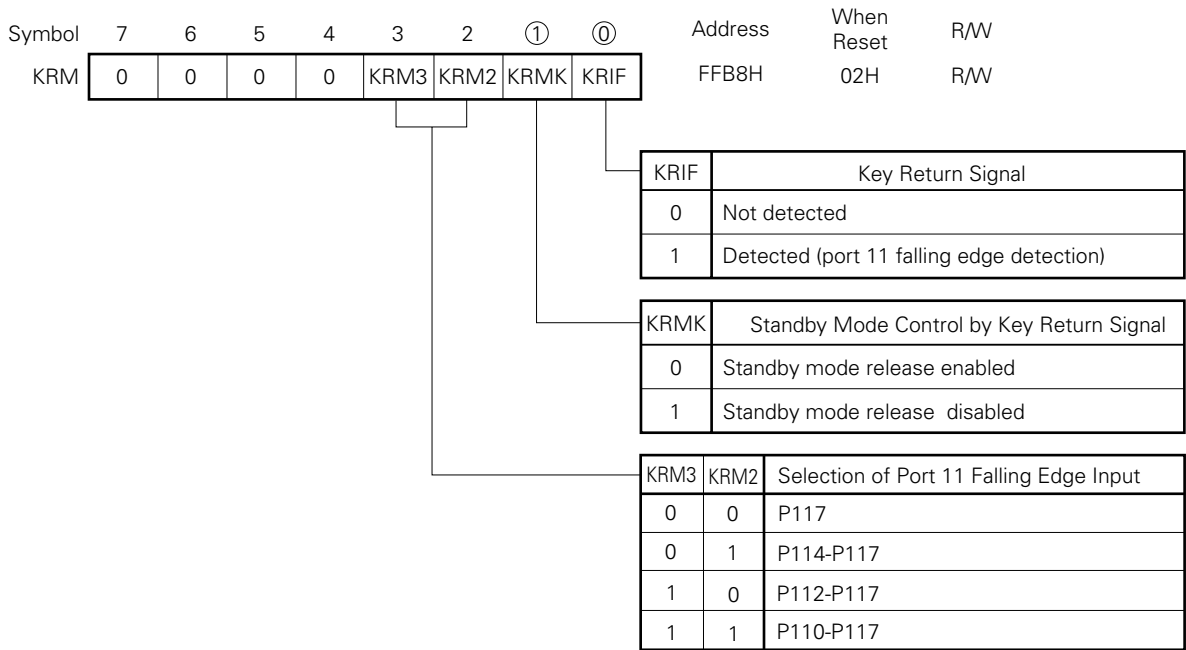
(3) Key return mode register (KRM)

This register is used to set enable/disable of standby function clear by key return signal (port 11 falling edge detection), and selects port 11 falling edge input.

KRM is set with a 1-bit or 8-bit memory manipulation instruction.

$\overline{\text{RESET}}$ input sets KRM to 02H.

Figure 19-21. Key Return Mode Register Format



Caution When port 11 falling edge detection is used, be sure to clear KRIF to 0 (not cleared to 0 automatically).

19.5.2 Test input signal acknowledge operation

(1) Internal test signal

If the watch timer overflows, the WTIF flag is set. The watch function is available by checking the WTIF flag at a shorter cycle than the watch timer overflow cycle.

(2) External test signal

When a falling edge is input to the port 4 (P110 to P117) pins, KRIF is set. If port 11 is used as key matrix return signal input, whether or not a key input has been applied can be checked from the KRIF status.

20.1 Standby Function and Configuration

20.1.1 Standby function

The standby function is designed to decrease power consumption of the system. The following two modes are available.

(1) HALT mode

HALT instruction execution sets the HALT mode. The HALT mode is intended to stop the CPU operation clock. System clock oscillator continues oscillation. In this mode, current consumption cannot be decreased as in the STOP mode. The HALT mode is valid to restart immediately upon interrupt request and to carry out intermittent operations such as in watch applications.

(2) STOP mode

STOP instruction execution sets the STOP mode. In the STOP mode, the main system clock oscillator stops and the whole system stops. CPU current consumption can be considerably decreased.

Data memory low-voltage hold (down to $V_{DD} = 1.8$ V) is possible. Thus, the STOP mode is effective to hold data memory contents with ultra-low current consumption. Because this mode can be cleared upon interrupt request, it enables intermittent operations to be carried out.

However, because a wait time is necessary to secure an oscillation stabilization time after the STOP mode is cleared, select the HALT mode if it is necessary to start processing immediately upon interrupt request.

In any mode, all the contents of the register, flag and data memory just before standby mode setting are held. The input/output port output latch and output buffer statuses are also held.

- Cautions**
- 1. The STOP mode can be used only when the system operates with the main system clock (subsystem clock oscillation cannot be stopped). The HALT mode can be used with either the main system clock or the subsystem clock.**
 - 2. When proceeding to the STOP mode, be sure to stop the peripheral hardware operation and execute the STOP instruction.**
 - 3. The following sequence is recommended for power consumption reduction of the A/D converter when the standby function is used: first clear bit 7 (CS) of ADM to 0 to stop the A/D conversion operation, and then execute the HALT or STOP instruction.**

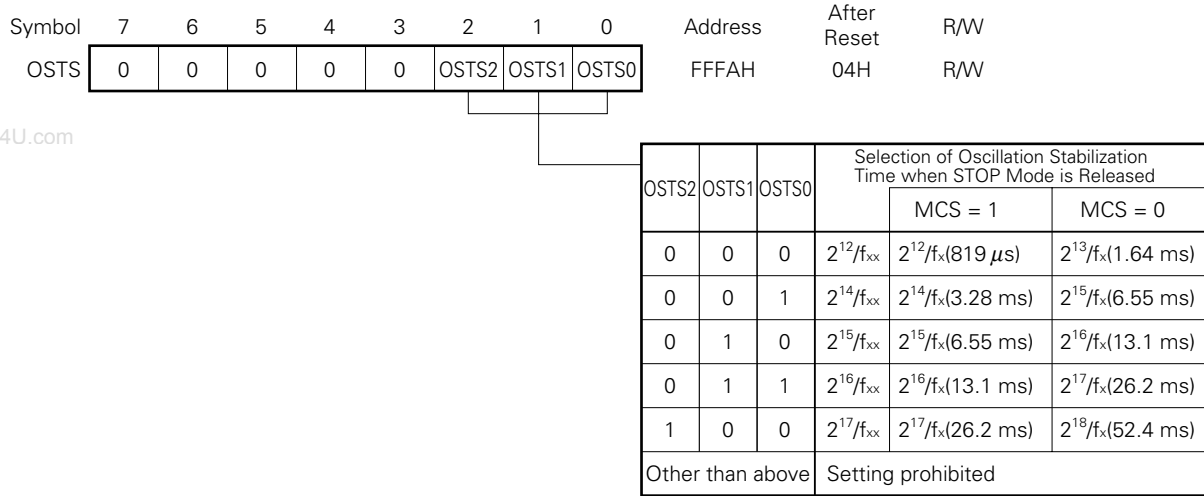
20.1.2 Standby function control register

A wait time after the STOP mode is cleared upon interrupt request till the oscillation stabilizes is controlled with the oscillation stabilization time select register (OSTS).

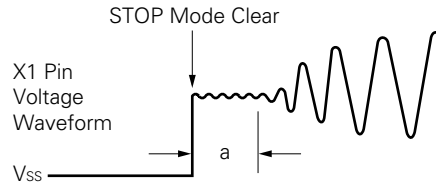
OSTS is set with an 8-bit memory manipulation instruction.

$\overline{\text{RESET}}$ input sets OSTS to 04H. However, it takes $2^{17}/f_x$, not $2^{18}/f_x$, until the STOP mode is cleared by $\overline{\text{RESET}}$ input.

Figure 20-1. Oscillation Stabilization Time Select Register Format



Caution The wait time after STOP mode clear does not include the time (see "a" in the illustration below) from STOP mode clear to clock oscillation start, regardless of clearance by $\overline{\text{RESET}}$ input or by interrupt generation.



- Remarks**
1. f_{xx} : Main system clock frequency (f_x or $f_x/2$)
 2. f_x : Main system clock oscillation frequency
 3. MCS : Oscillation mode select register bit 0
 4. Values in parentheses apply to operating at $f_x = 5.0 \text{ MHz}$

20.2 Standby Function Operations

20.2.1 HALT mode

(1) HALT mode set and operating status

The HALT mode is set by executing the HALT instruction. It can be set with the main system clock or the subsystem clock.

The operating status in the HALT mode is described below.

Table 20-1. HALT Mode Operating Status

*

HALT mode setting		HALT execution during main system clock operation		HALT execution during subsystem clock operation	
		w/ subsystem clock (Note1)	w/o. subsystem clock (Note2)	Main system clock oscillates	Main system clock stops
Item					
Clock Generator		Both main system and subsystem clocks can be oscillated. Clock supply to the CPU stops.			
CPU		Operation stop.			
Port (output latch)		Status before HALT mode setting is held.			
16-bit timer/event counter		Operable.		Operable when watch timer output with fXT selected as count clock (fXT is selected as count clock for watch timer).	
8-bit timer/event counter 1 and 2		Operable.		Operable when TI1 or TI2 is selected as count clock.	
Watch timer		Operable if fxx/2 ⁷ is selected as count clock.	Operable.		Operable if fXT is selected as count clock.
Watchdog timer		Operable.		Operable.	
A/D converter		Operable.			Operation stops.
Serial Interface		Operable			Operable at external SCK.
LCD controller/driver		Operable if fxx/2 ⁷ is selected as count clock.	Operable.		Operable if fXT is selected as count clock.
External interrupt	INTP0	Operable when a clock (fxx/2 ⁵ , fxx/2 ⁶ , fxx/2 ⁷) for the peripheral hardware is selected as sampling clock.			Operation stops.
	INTP1 to INTP5	Operable.			

Notes 1. Including case when external clock is supplied.

2. Including case when external clock is not supplied.

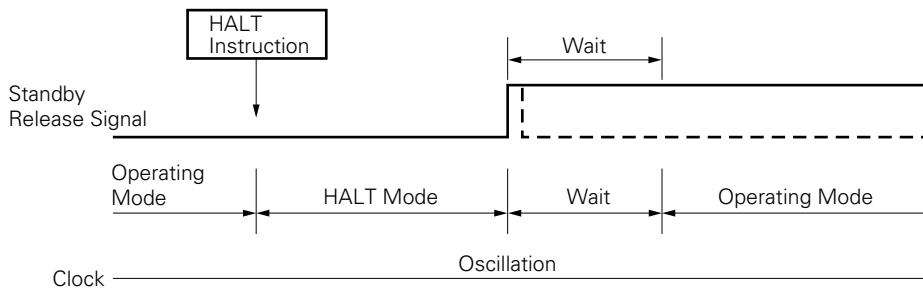
(2) HALT mode clear

The HALT mode can be cleared with the following four types of sources.

(a) Clear upon unmasked interrupt request

An unmasked interrupt request is used to clear the HALT mode. If interrupt acknowledge is enabled, vectored interrupt service is carried out. If disabled, the next address instruction is executed.

Figure 20-2. HALT Mode Clear upon Interrupt Generation



Remarks 1. The broken line indicates the case when the interrupt request which has cleared the standby status is acknowledged.

2. Wait time will be as follows:

- When vectored interrupt service is carried out: 8 to 9 clocks
- When vectored interrupt service is not carried out: 2 to 3 clocks

(b) Clear upon non-maskable interrupt request

The HALT mode is cleared and vectored interrupt service is carried out whether interrupt acknowledge is enabled or disabled.

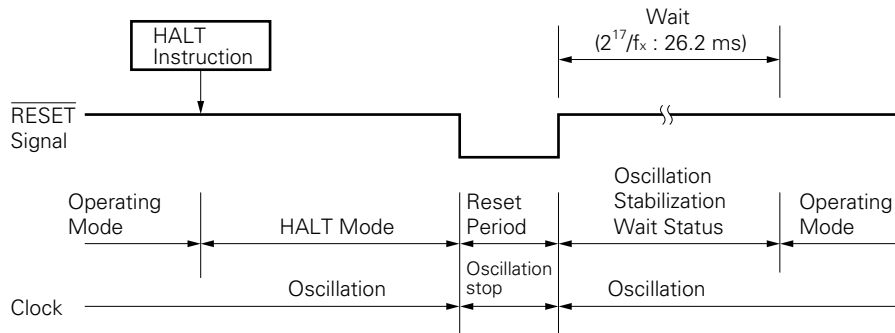
(c) Clear upon unmasked test input

The HALT mode is cleared by unmasked test input and the next address instruction of the HALT instruction is executed.

(d) Clear upon $\overline{\text{RESET}}$ input

As is the case with normal reset operation, a program is executed after branch to the reset vector address.

Figure 20-3. HALT Mode Release by $\overline{\text{RESET}}$ Input



- Remarks**
1. f_x : Main system clock oscillation frequency
 2. Time value in parentheses is when $f_x = 5.0$ MHz.

Table 20-2. Operation after HALT Mode Release

Release Source	MKxx	PRxx	IE	ISP	Operation
Maskable interrupt request	0	0	0	×	Next address instruction execution
	0	0	1	×	Interrupt service execution
	0	1	0	1	Next address instruction execution
	0	1	×	0	
	0	1	1	1	Interrupt service execution
	1	×	×	×	HALT mode hold
Non-maskable interrupt request	–	–	×	×	Interrupt service execution
Test input	0	–	×	×	Next address instruction execution
	1	–	×	×	HALT mode hold
$\overline{\text{RESET}}$ input	–	–	×	×	Reset processing

x: Don't care

20.2.2 STOP mode

(1) STOP mode set and operating status

The STOP mode is set by executing the STOP instruction. It can be set only with the main system clock.

- * **Cautions**
1. When the STOP mode is set, the X2 pin is internally connected to V_{DD} via a pull-up resistor to minimize the leakage current at the crystal oscillator. Thus, do not use the STOP mode in a system where an external clock is used for the main system clock.
 2. Because the interrupt request signal is used to clear the standby mode, if there is an interrupt source with the interrupt request flag set and the interrupt mask flag reset, the standby mode is immediately cleared if set. Thus, the STOP mode is reset to the HALT mode immediately after execution of the STOP instruction. After the wait set using the oscillation stabilization time select register (OSTS), the operating mode is set.

The operating status in the STOP mode is described below.

* **Table 20-3. STOP Mode Operating Status**

STOP mode setting		With subsystem clock		Without subsystem clock	
		Item		Item	
Clock Generator		Only main system clock stops oscillation.			
CPU		Operation stop.			
Port (output latch)		Status before STOP mode setting is held.			
16-bit timer/event counter		Operable when watch timer output with f _{XT} selected is selected as count clock (f _{XT} is selected as count clock for watch timer).		Operation stops.	
8-bit timer/event counter 1 and 2		Operable when TI1 and TI2 are selected for the count clock.			
Watch timer		Operable when f _{XT} is selected for the count clock.		Operation stops.	
Watchdog timer		Operation stops.			
A/D converter		Operation stops.			
Serial Interface	Other than UART	Operable when externally supplied clock is specified as the serial clock.			
	UART	Operation stops.			
LCD controller/driver		Operable when f _{XT} is selected for the count clock.		Operation stops.	
External interrupt	INTP0	Operation is impossible.			
	INTP1 to INTP5	Operable.			

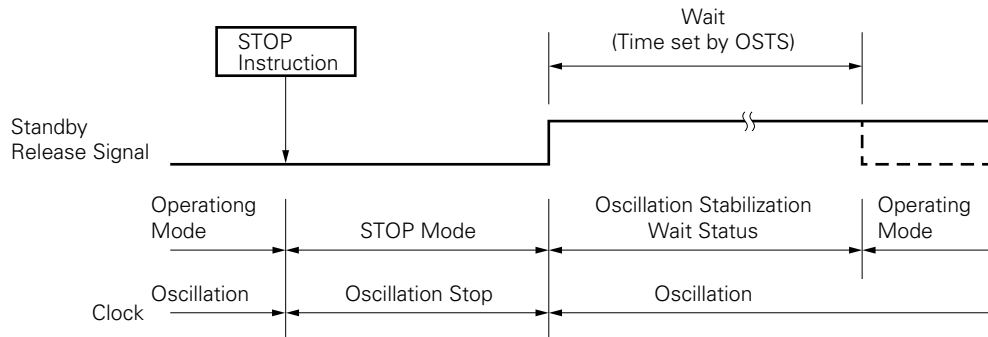
(2) STOP mode release

The STOP mode can be cleared with the following three types of sources.

(a) Release by unmasked interrupt request

An unmasked interrupt request is used to release the STOP mode. If interrupt acknowledge is enabled after the lapse of oscillation stabilization time, vectored interrupt service is carried out. If interrupt acknowledge is disabled, the next address instruction is executed.

Figure 20-4. STOP Mode Release by Interrupt Generation



Remark The broken line indicates the case when the interrupt request which has cleared the standby status is acknowledged.

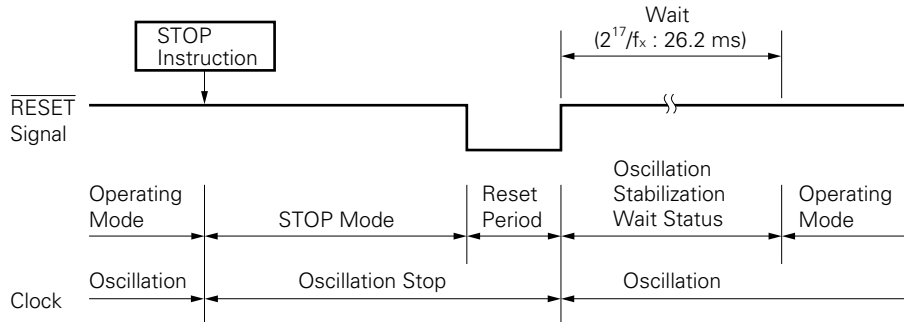
(b) Release by unmasked test input

The STOP mode is cleared by unmasked test input. After the lapse of oscillation stabilization time, the instruction at the next address of the STOP instruction is executed.

(c) Release by $\overline{\text{RESET}}$ input

The STOP mode is cleared and after the lapse of oscillation stabilization time, reset operation is carried out.

Figure 20-5. Release by STOP Mode $\overline{\text{RESET}}$ Input



- Remarks**
1. f_x : Main system clock oscillation frequency
 2. Time value in parentheses is when $f_x = 5.0 \text{ MHz}$.

Table 20-4. Operation after STOP Mode Release

Release Source	MKxx	PRxx	IE	ISP	Operation
Maskable interrupt request	0	0	0	×	Next address instruction execution
	0	0	1	×	Interrupt service execution
	0	1	0	1	Next address instruction execution
	0	1	×	0	
	0	1	1	1	Interrupt service execution
	1	×	×	×	STOP mode hold
$\overline{\text{TEST}}$ input	0	–	×	×	Next address instruction execution
	1	–	×	×	STOP mode hold
$\overline{\text{RESET}}$ input	–	–	×	×	Reset processing

x: Don't care

CHAPTER 21 RESET FUNCTION

21.1 Reset Function

The following two operations are available to generate the reset signal.

- (1) External reset input with $\overline{\text{RESET}}$ pin
- (2) Internal reset by watchdog timer overrun time detection

External reset and internal reset have no functional differences. In both cases, program execution starts at the address at 0000H and 0001H by $\overline{\text{RESET}}$ input.

When a low level is input to the $\overline{\text{RESET}}$ pin or the watchdog timer overflows, a reset is applied and each hardware is set to the status as shown in Table 21-1. Each pin has high impedance during reset input or during oscillation stabilization time just after reset clear.

When a high level is input to the $\overline{\text{RESET}}$ input, the reset is cleared and program execution starts after the lapse of oscillation stabilization time ($2^{17}/f_x$). The reset applied by watchdog timer overflow is automatically cleared after a reset and program execution starts after the lapse of oscillation stabilization time ($2^{17}/f_x$) (see **Figure 21-2** to **21-4**).

- Cautions**
- 1. For an external reset, input a low level for 10 μs or more to the $\overline{\text{RESET}}$ pin.**
 - 2. During reset input, main system clock oscillation remains stopped but subsystem clock oscillation continues.**
 - 3. When the STOP mode is cleared by reset, the STOP mode contents are held during reset input. However, the port pin becomes high-impedance.**

Figure 21-1. Block Diagram of Reset Function

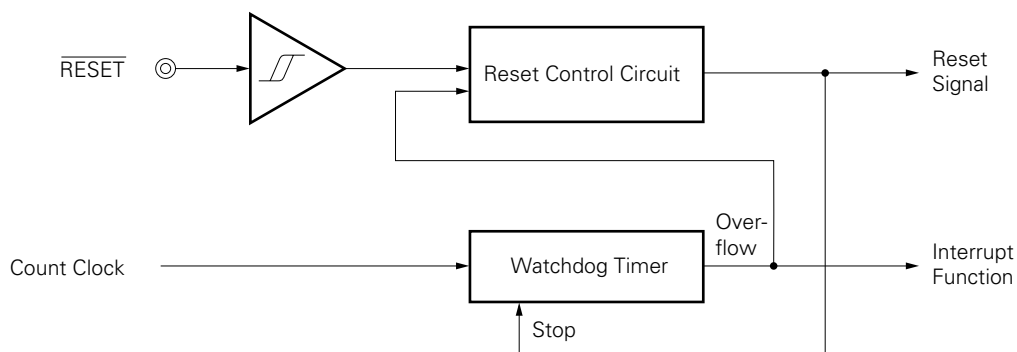


Figure 21-2. Timing of Reset Input by $\overline{\text{RESET}}$ Input

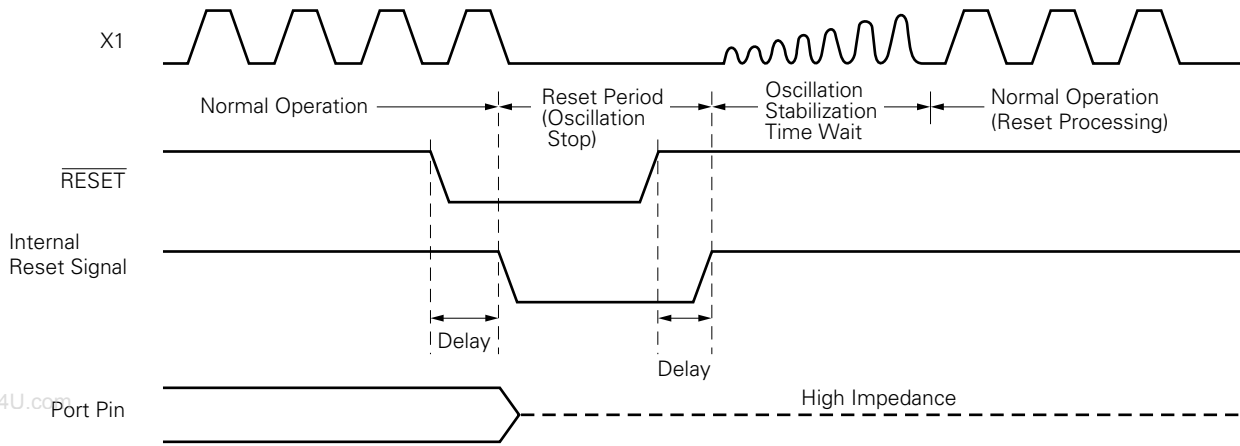


Figure 21-3. Timing of Reset due to Watchdog Timer Overflow

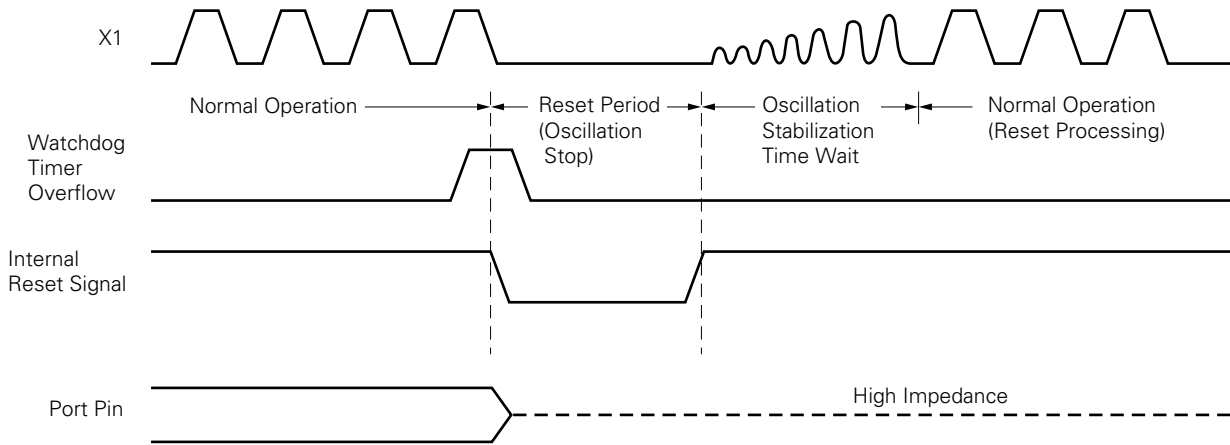


Figure 21-4. Timing of Reset Input in STOP Mode by $\overline{\text{RESET}}$ Input

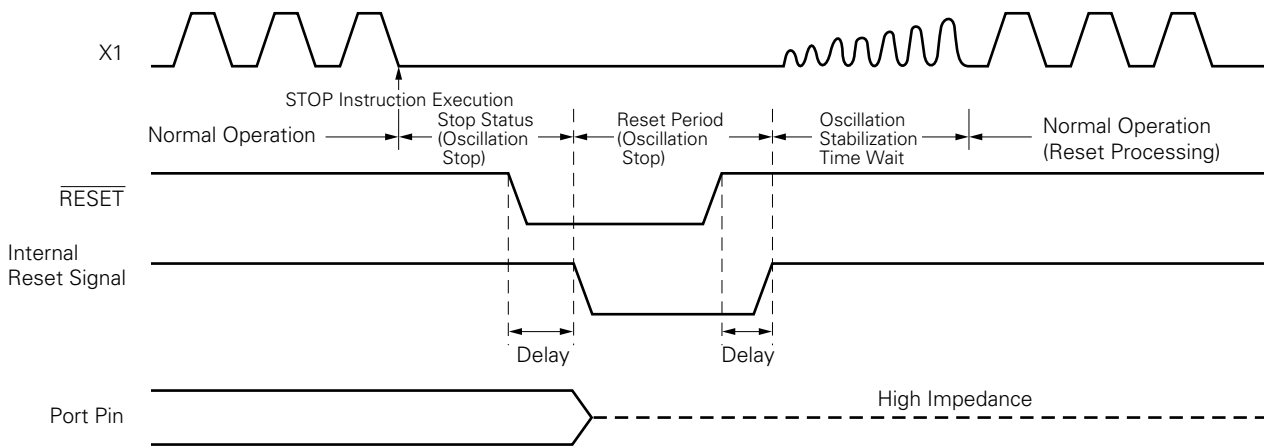


Table 21-1. Hardware Status after Reset (1/2)

Hardware		Status after Reset
Program counter (PC) Note1		The contents of reset vector tables (0000H and 0001H) are set.
Stack pointer (SP)		Undefined
Program status word (PSW)		02H
RAM	Data memory	Undefined Note2
	General register	Undefined Note2
Port (Output latch)	Ports 0 to 3, Port 7 to 11 (P0-P3, P7-P11)	00H
Port mode register (PM0 to PM3, PM5 to PM7, PM12, PM13)		FFH
Pull-up resistor option register (PUOH, PUOL)		00H
Processor clock control register (PCC)		04H
Oscillation mode selection register (OSMS)		00H
Memory size switching register (IMS)		Note3
Oscillation stabilization time select register (OSTS)		04H
16-bit timer/event counter	Timer register (TM0)	00H
	Capture/compare register (CR00, CR01)	Undefined
	Clock selection register (TCL0)	00H
	Mode control register (TMC0)	00H
	Capture/compare control register 0 (CRC0)	04H
	Output control register (TOC0)	00H
8-bit timer/event counter 1, 2	Timer register (TM1, TM2)	00H
	Compare registers (CR10, CR20)	Undefined
	Clock select register (TCL1)	00H
	Mode control registers (TMC1)	00H
	Output control register (TOC1)	00H

Notes 1. During reset input or oscillation stabilization time wait, only the PC contents among the hardware statuses become undefined. All other hardware statuses remains unchanged after reset.

2. The post-reset status is held in the standby mode.

3. The values after reset depend on the product.

μ PD78062, 78062Y : 44H, μ PD78063, 78063Y : C6H, μ PD78064, 78064Y : C8H,

μ PD78P064, 78P064Y : C8H

Table 21-1. Hardware Status after Reset (2/2)

	Hardware	Status after Reset
* Watch timer	Mode control register (TMC2)	00H
	Clock select register (TCL2)	00H
Watchdog timer	Mode register (WDTM)	00H
	Clock select register (TCL3)	88H
Serial interface	Shift registers (SIO0)	Undefined
	Mode registers (CSIM0, CSIM2)	00H
	Serial bus interface control register (SBIC)	00H
	Slave address register (SVA)	Undefined
	Asynchronous serial interface mode register (ASIM)	00H
	Asynchronous serial interface status register (ASIS)	00H
	Baud rate generator control register (BRGC)	00H
	Transmit shift register (TXS)	FFH
	Receive buffer register (RXB)	
	Interrupt timing specify register (SINT)	00H
	A/D converter	Mode register (ADM)
Conversion result register (ADCR)		Undefined
Input select register (ADIS)		00H
LCD controller/driver	Display mode register (LCDM)	00H
	Display control register (LCDC)	00H
Interrupt	Request flag register (IF0L, IF0H, IF1L)	00H
	Mask flag register (MK0L, MK0H, MK1L)	FFH
	Priority specify flag register (PR0L, PR0H, PR1L)	FFH
	External interrupt mode register (INTM0, INTM1)	00H
	Key return mode register (KRM)	02H
	Sampling clock select register (SCS)	00H

CHAPTER 22 μ PD78P064, 78P064Y

The μ PD78P064, 78P064Y replace the internal mask ROM of the μ PD78064, 78064Y with one-time PROM or EPROM. Table 22-1 lists the differences among the μ PD78P064, 78P064Y and the mask ROM versions.

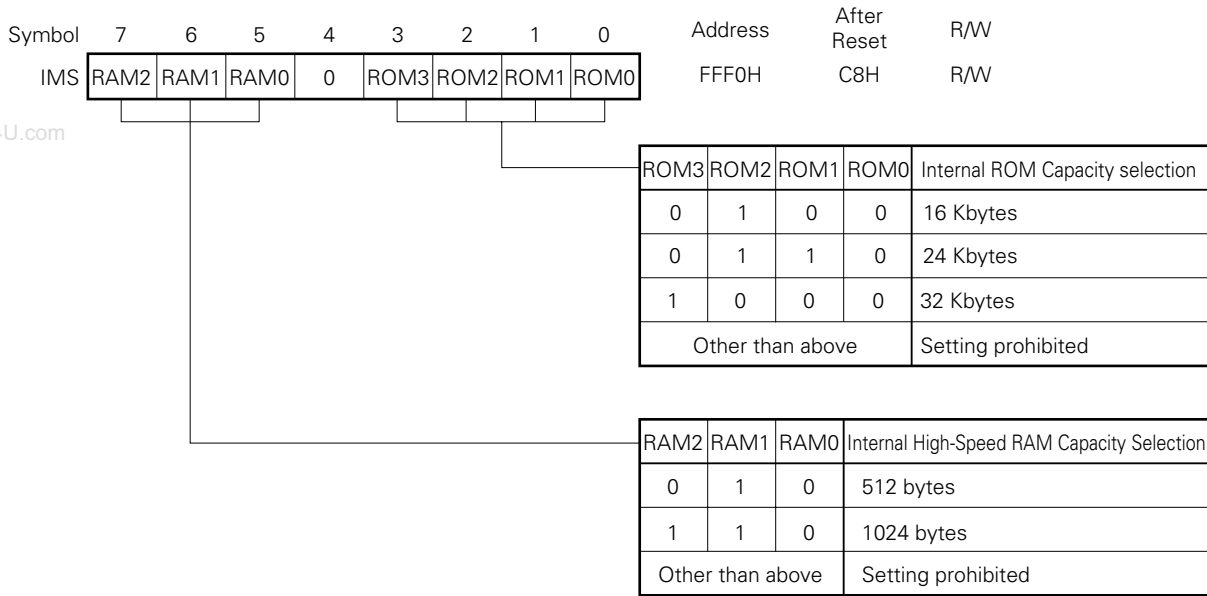
Table 22-1. Differences among μ PD78P064, 78P064Y and Mask ROM Versions

Item	μ PD78P064, 78P064Y	Mask ROM versions
IC pin	None	Available
V _{PP} pin	Available	None
On-chip mask option split resistors for LCD driving power supply	None	Available

22.1 Memory Size Switching Register

The μ PD78P064, 78P064Y allows users to define its internal ROM and high-speed RAM sizes using the memory size switching register (IMS), so that the same memory mapping as that of a mask ROM version with a different-size internal ROM and high-speed RAM is possible. IMS is set with an 8-bit memory manipulation instruction. $\overline{\text{RESET}}$ input sets IMS to C8H.

Figure 22-1. Memory Size Switching Register Format



The IMS settings to give the same memory map as mask ROM versions are shown in Table 22-2.

Table 22-2. Examples of Memory Size Switching Register Settings

Relevant Mask ROM Version	IMS Setting
μ PD78062, 78062Y	44H
μ PD78063, 78063Y	C6H
μ PD78064, 78064Y	C8H

22.2 PROM Programming

The μ PD78P064 and 78P064Y each incorporate a 32-Kbyte PROM as program memory. To write a program into the μ PD78P054 or 78P058 PROM, make the device enter the PROM programming mode by setting the levels of the V_{PP} and $\overline{\text{RESET}}$ pins as specified. For the connection of unused pins, see paragraph (2) “PROM Programming Mode” in section 1.4.

Caution Write the program in the range of addresses 0000H to 7FFFH (specify the last address as 7FFFH.) The program cannot be correctly written by a PROM programmer which does not have a write address specification function.

22.2.1 Operating modes

When +5 V or +12.5 V is applied to the V_{PP} pin and a low-level signal is applied to the $\overline{\text{RESET}}$ pin, the μ PD78P064 and μ PD78P064Y are set to the PROM programming mode. This is one of the operating modes shown in Table 22-3 below according to the setting of the $\overline{\text{CE}}$, $\overline{\text{OE}}$, and $\overline{\text{PGM}}$ pins.

The PROM contents can be read by setting the read mode.

Table 22-3. PROM Programming Operating Modes

Operating mode	Pin						
	$\overline{\text{RESET}}$	V_{PP}	V_{DD}	$\overline{\text{CE}}$	$\overline{\text{OE}}$	$\overline{\text{PGM}}$	D0-D7
Page data latch	L	+12.5 V	+6.5 V	H	L	H	Data input
Page write				H	H	L	High impedance
Byte write				L	H	L	Data input
Program verify				L	L	H	Data output
Program inhibit				×	H	H	High impedance
				×	L	L	
Read		+5 V	+5V	L	L	H	Data output
Output disabled				L	H	×	High impedance
Standby				H	×	×	High impedance

x: L or H

(1) Read mode

Read mode is set by setting $\overline{\text{CE}}$ to L and $\overline{\text{OE}}$ to L.

(2) Output disable mode

If $\overline{\text{OE}}$ is set to H, data output becomes high impedance and the output disable mode is set.

Therefore, if multiple μ PD78P064s or 78P064Ys are connected to the data bus, data can be read from any one device by controlling the $\overline{\text{OE}}$ pin.

(3) Standby mode

Setting \overline{CE} to H sets the standby mode.

In this mode, data output becomes high impedance irrespective of the status of \overline{OE} .

(4) Page data latch mode

Setting \overline{CE} to H, \overline{PGM} to H, and \overline{OE} to L at the start of the page write mode sets the page data latch mode.

In this mode, 1-page 4-byte data is latched in the internal address/data latch circuit.

(5) Page write mode

After a 1-page 4-byte address and data are latched by the page data latch mode, a page write is executed by applying a 0.1-ms program pulse (active-low) to the \overline{PGM} pin while $\overline{CE}=H$ and $\overline{OE}=H$. After this, program verification can be performed by setting \overline{CE} to L and \overline{OE} to L.

If programming is not performed by one program pulse, repeated write and verify operations are executed X times ($X \leq 10$).

(6) Byte write mode

A byte write is executed by applying a 0.1-ms program pulse (active-low) to the \overline{PGM} pin while $\overline{CE}=L$ and $\overline{OE}=H$. After this, program verification can be performed by setting \overline{OE} to L.

If programming is not performed by one program pulse, repeated write and verify operations are executed X times ($X \leq 10$).

(7) Program verify mode

Setting \overline{CE} to L, \overline{PGM} to H, and \overline{OE} to L sets the program verify mode.

After writing is performed, this mode should be used to check whether the data was written correctly.

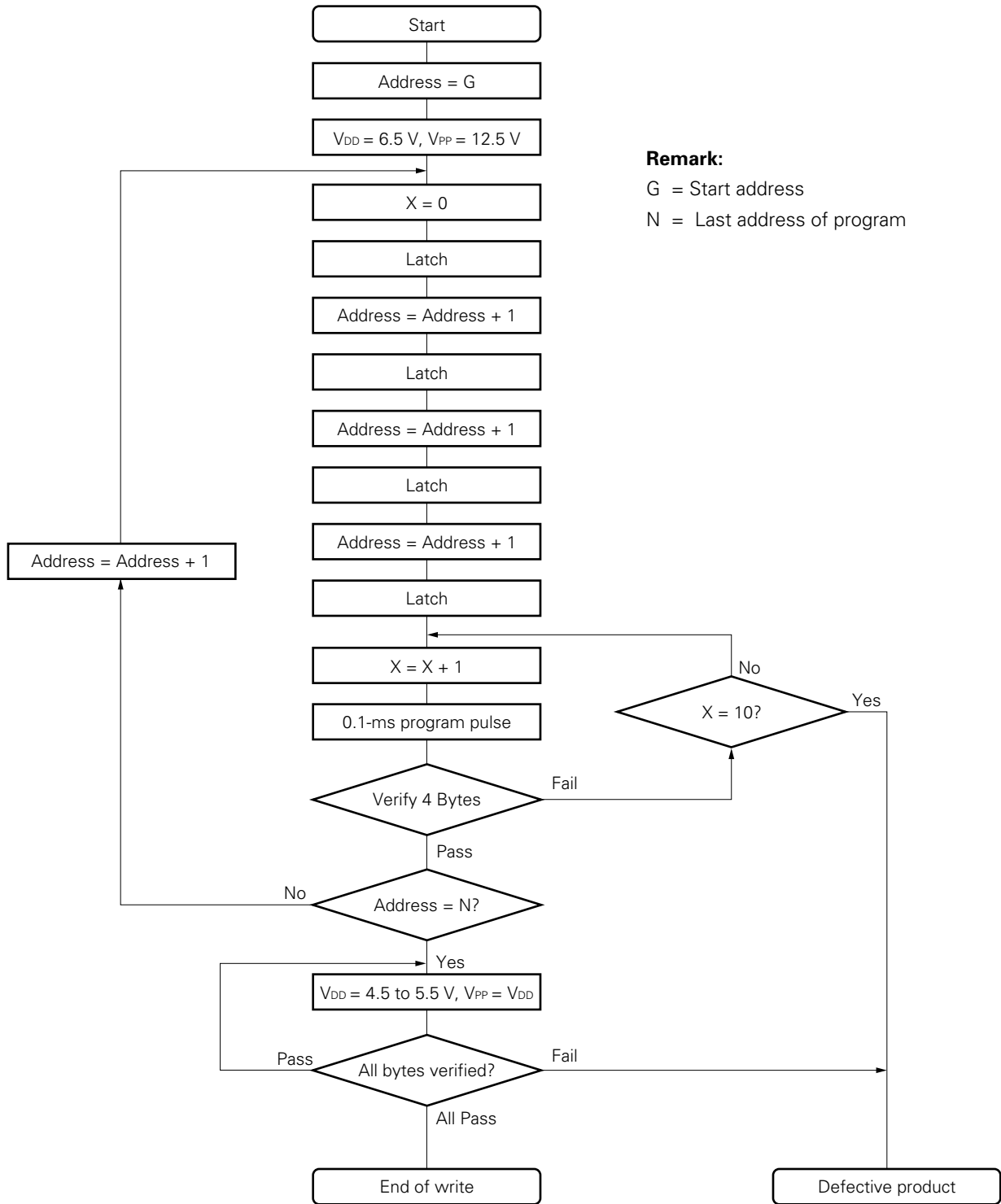
(8) Program inhibit mode

The program inhibit mode is used when the \overline{OE} pins, V_{PP} pins and pins D0 to D7 of multiple μ PD78P064s or 78P064Ys are connected in parallel and any one of these devices must be written to.

The page write mode or byte write mode described above is used to perform a write. At this time, the write is not performed on the device which has the \overline{PGM} pin driven high.

22.2.2 PROM write procedure

Figure 22-2. Page Program Mode Flowchart



Remark:
 G = Start address
 N = Last address of program

www.DataSheet4U.com

Figure 22-3. Page Program Mode Timing

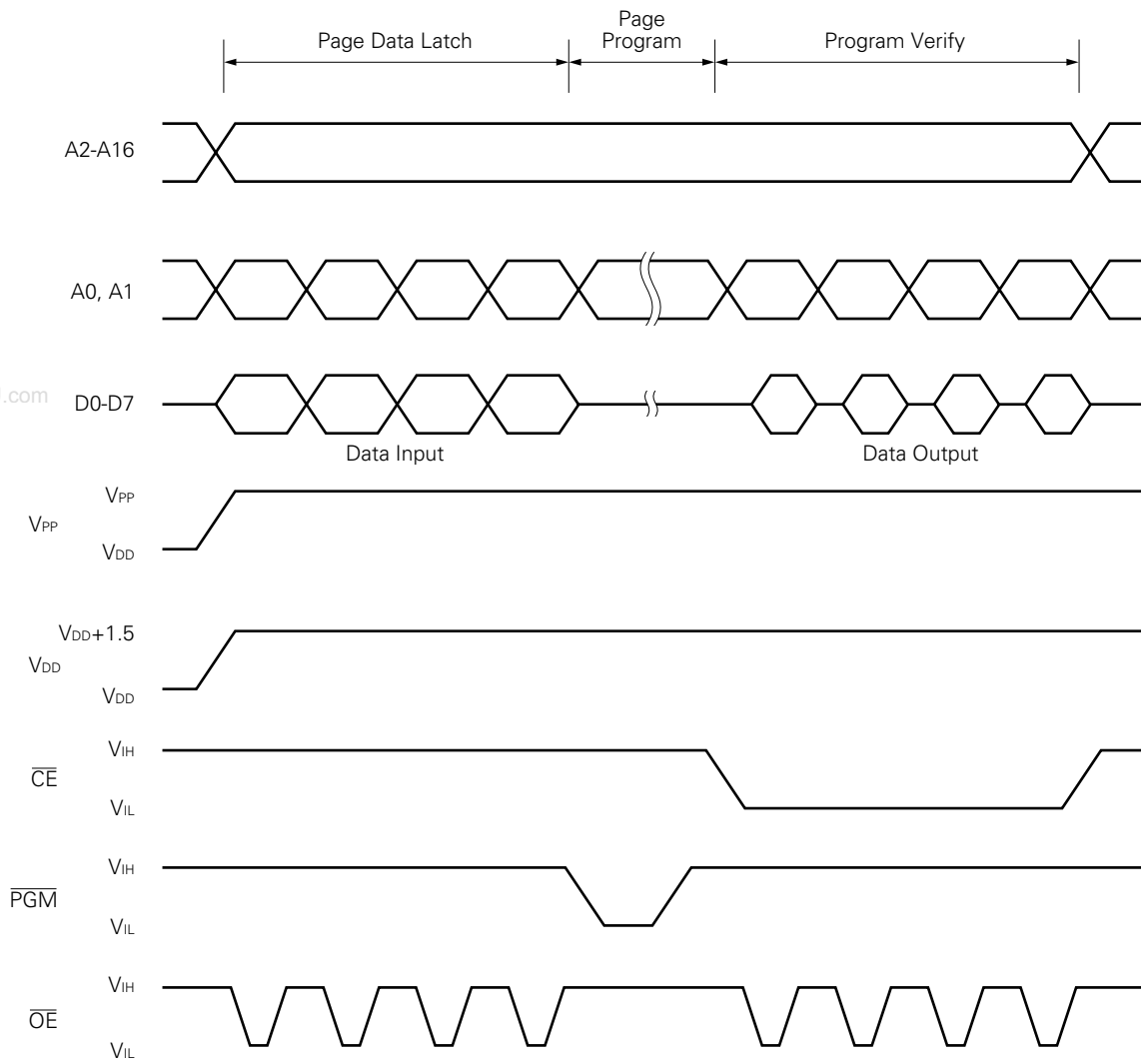
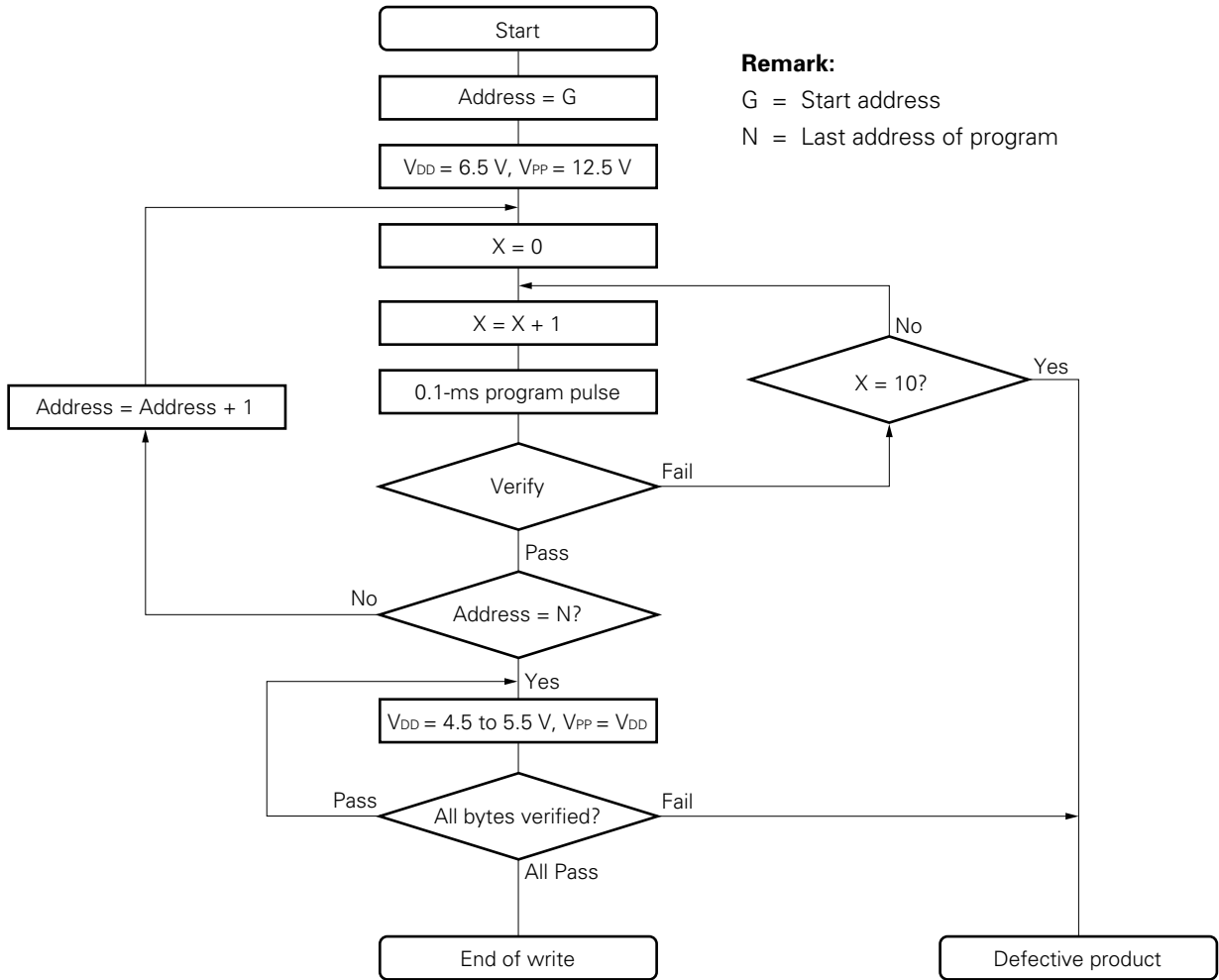
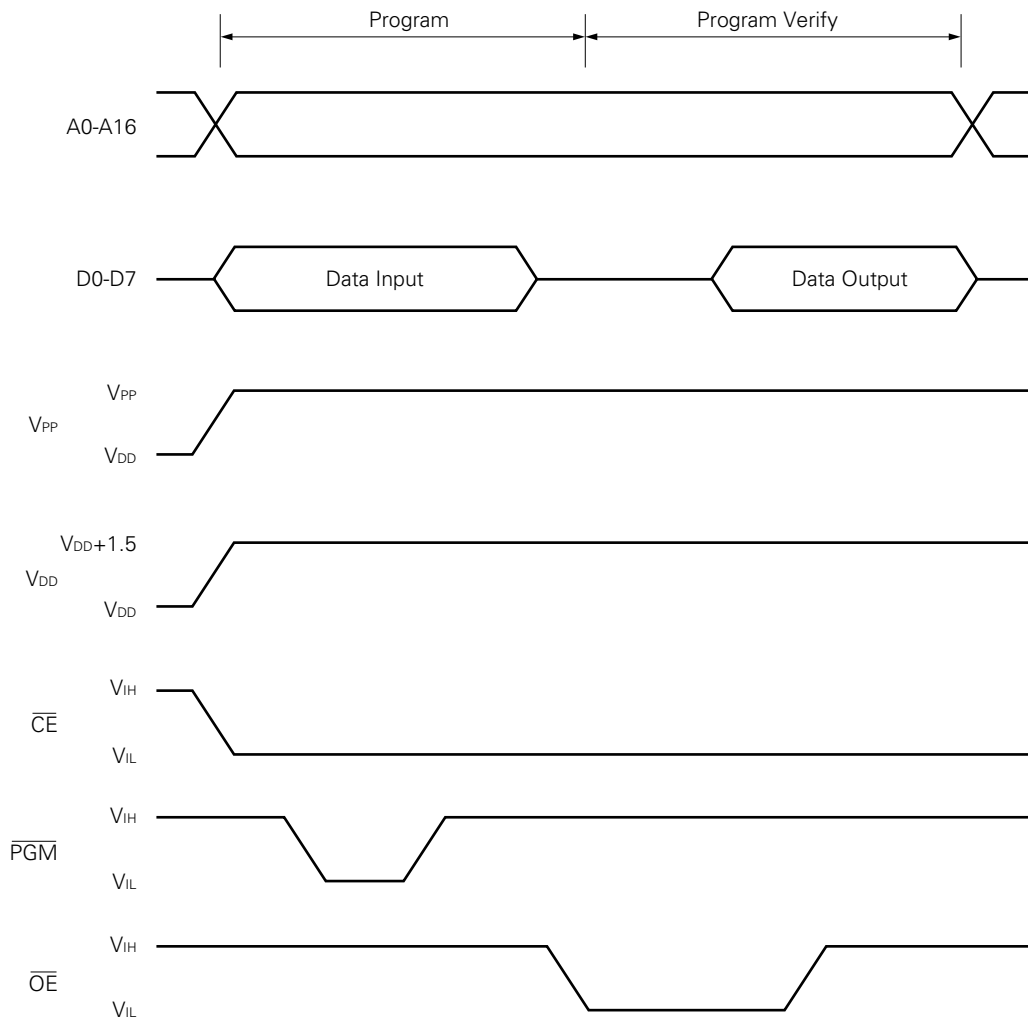


Figure 22-4. Byte Program Mode Flowchart



www.DataSheet4U.com

Figure 22-5. Byte Program Mode Timing



- Cautions**
1. Be sure to apply V_{DD} before applying V_{PP}, and remove it after removing V_{PP}.
 2. V_{PP} must not exceed +13.5 V including overshoot voltage.
 3. Disconnecting/inserting the device from/to the on-board socket while +12.5 V is being applied to the V_{PP} pin may have an adverse affect on device reliability.

22.2.3 PROM reading procedure

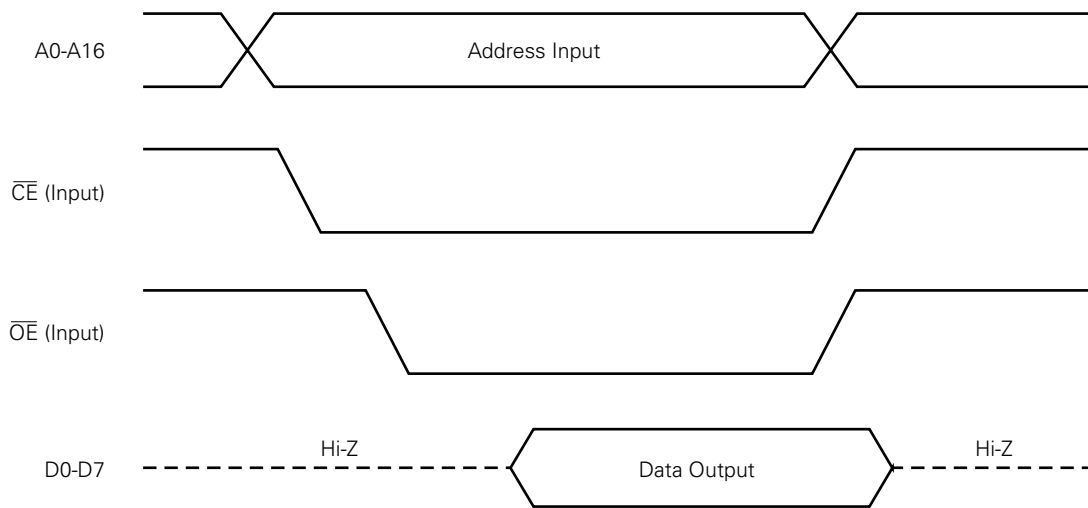
PROM contents can be read onto the external data bus (D0 to D7) using the following procedure.

- (1) Fix the $\overline{\text{RESET}}$ pin low, and supply +5 V to the V_{PP} pin. Unused pins are handled as shown in paragraph, **(2) "PROM Programming Mode"** in section 1.4.
- (2) Supply +5 V to the V_{DD} and V_{PP} pins.
- (3) Input the address of data to be read to pins A0 through A16.
- (4) Read mode is entered.
- (5) Data is output to pins D0 through D7.

The timing for steps (2) through (5) above is shown in Figure 22-6.

www.DataSheet4U.com

Figure 22-6. PROM Read Timing



22.3 Erasure Procedure (μ PD78P064KL-T and 78P064YKL-T Only)

With the μ PD78P064KL-T or 78P064YKL-T, it is possible to erase (or set all contents to FFH) the data contents written in the program memory, and rewrite the memory.

The data can be erased by exposing the window to light with a wavelength of approximately 400 nm or shorter. Typically, data is erased by 254-nm ultraviolet light rays. The minimum lighting level to completely erase the written data is shown below.

- UV intensity \times exposure time: 15 W·s/cm² or more
- Exposure time: 15 to 20 minutes (using a 12 mW/cm² ultraviolet lamp. A longer exposure time may be required in case of deterioration of the ultraviolet lamp or dirt on the package window).

When erasing written data, remove any filter on the window and place the device within 2.5 cm of the lamp tube.

22.4 Opaque Film Masking the Window (μ PD78P064KL-T and 78P064YKL-T Only)

To prevent unintentional erasure of the EPROM contents by light and to prevent internal circuits from malfunction due to light coming in through the erasure window, mask the window with opaque film after writing the EPROM.

22.5 Screening of One-Time PROM Versions

One-time PROM versions (μ PD78P064GC-7EA, μ PD78P064YGC-7EA, μ PD78P064GF-3BA, and μ PD78P064YGF-3BA) cannot be fully tested by NEC before shipment due to the structure of one-time PROM. Therefore, after users have written data into the PROM, screening should be implemented by user: that is, store devices at high temperature for one day as specified below, and verify their contents after the devices have returned to room temperature.

Storage Temperature	Storage Time
125°C	24 hours

- * For users who do not wish to implement screening by themselves, NEC provides such users with a charged service in which NEC performs a series of processes from writing one-time PROMs and screening them to verifying their contents for users by request. The PROM version devices which provide this service are called QTOP™ microcontrollers. For details, please consult an NEC sales representative.

CHAPTER 23 INSTRUCTION SET

This chapter describes each instruction set of the μ PD78064 and 78064Y subseries as list table. For details of its operation and operation code, refer to the separate document **“78K/0 series USER’S MANUAL—Instruction (U12326E).”**

23.1 Legends Used in Operation List

23.1.1 Operand identifiers and description methods

Operands are described in “Operand” column of each instruction in accordance with the description method of the instruction operand identifier (refer to the assembler specifications for detail). When there are two or more description methods, select one of them. Alphabetic letters in capitals and symbols, #, !, \$ and [] are key words and must be described as they are. Each symbol has the following meaning.

- # : Immediate data specification
- ! : Absolute address specification
- \$: Relative address specification
- [] : Indirect address specification

www.DataSheet4U.com

In the case of immediate data, describe an appropriate numeric value or a label. When using a label, be sure to describe the #, !, \$, and [] symbols.

For operand register identifiers, r and rp, either function names (X, A, C, etc.) or absolute names (names in parentheses in the table below, R0, R1, R2, etc.) can be used for description.

Table 23-1. Operand Identifiers and Description Methods

Identifier	Description Method
r	X (R0), A (R1), C (R2), B (R3), E (R4), D (R5), L (R6), H (R7),
rp	AX (RP0), BC (RP1), DE (RP2), HL (RP3)
sfr	Special-function register symbol ^{Note}
sfrp	Special-function register symbol (16-bit manipulatable register even addresses only) ^{Note}
saddr	FE20H-FF1FH Immediate data or labels
saddrp	FE20H-FF1FH Immediate data or labels (even address only)
addr16	0000H-FFFFH Immediate data or labels (Only even addresses for 16-bit data transfer instructions)
addr11	0800H-0FFFH Immediate data or labels
addr5	0040H-007FH Immediate data or labels (even address only)
word	16-bit immediate data or label
byte	8-bit immediate data or label
bit	3-bit immediate data or label
RBn	RB0 to RB3

Note Addresses from FFD0H to FFDFH cannot be accessed with these operands.

Remark For special-function register symbols, refer to **Table 5-4 Special-Function Register List**.

23.1.2 Description of “operation” column

A	: A register; 8-bit accumulator
X	: X register
B	: B register
C	: C register
D	: D register
E	: E register
H	: H register
L	: L register
AX	: AX register pair; 16-bit accumulator
BC	: BC register pair
DE	: DE register pair
HL	: HL register pair
PC	: Program counter
SP	: Stack pointer
PSW	: Program status word
CY	: Carry flag
AC	: Auxiliary carry flag
Z	: Zero flag
RBS	: Register bank select flag
IE	: Interrupt request enable flag
NMIS	: Non-maskable interrupt servicing flag
()	: Memory contents indicated by address or register contents in parentheses
x _H , x _L	: Higher 8 bits and lower 8 bits of 16-bit register
∧	: Logical product (AND)
∨	: Logical sum (OR)
⊕	: Exclusive logical sum (exclusive OR)
—	: Inverted data
addr16	: 16-bit immediate data or label
jdisp8	: Signed 8-bit data (displacement value)

23.1.3 Description of “flag operation” column

(Blank)	: Not affected
0	: Cleared to 0
1	: Set to 1
x	: Set/cleared according to the result
R	: Previously saved value is restored

23.2 Operation List

Instruction Group	Mnemonic	Operands	Byte	Clock		Operation	Flag				
				Note 1	Note 2		Z	AC	CY		
8-bit data transfer	MOV	r, #byte	2	4	-	r ← byte					
		saddr, #byte	3	6	7	(saddr) ← byte					
		sfr, #byte	3	-	7	sfr ← byte					
		A, r	Note 3	1	2	-	A ← r				
		r, A	Note 3	1	2	-	r ← A				
		A, saddr		2	4	5	A ← (saddr)				
		saddr, A		2	4	5	(saddr) ← A				
		A, sfr		2	-	5	A ← sfr				
		sfr, A		2	-	5	sfr ← A				
		A, !addr16		3	8	9	A ← (addr16)				
		!addr16, A		3	8	9	(addr16) ← A				
		PSW, #byte		3	-	7	PSW ← byte	x	x	x	
		A, PSW		2	-	5	A ← PSW				
		PSW, A		2	-	5	PSW ← A	x	x	x	
		A, [DE]		1	4	5	A ← (DE)				
		[DE], A		1	4	5	(DE) ← A				
		A, [HL]		1	4	5	A ← (HL)				
		[HL], A		1	4	5	(HL) ← A				
		A, [HL + byte]		2	8	9	A ← (HL + byte)				
		[HL + byte], A		2	8	9	(HL + byte) ← A				
		A, [HL + B]		1	6	7	A ← (HL + B)				
		[HL + B], A		1	6	7	(HL + B) ← A				
		A, [HL + C]		1	6	7	A ← (HL + C)				
		[HL + C], A		1	6	7	(HL + C) ← A				
		XCH	A, r	Note 3	1	2	-	A ↔ r			
			A, saddr		2	4	6	A ↔ (saddr)			
			A, sfr		2	-	6	A ↔ (sfr)			
			A, !addr16		3	8	10	A ↔ (addr16)			
	A, [DE]			1	4	6	A ↔ (DE)				
	A, [HL]			1	4	6	A ↔ (HL)				
	A, [HL + byte]			2	8	10	A ↔ (HL + byte)				
	A, [HL + B]			2	8	10	A ↔ (HL + B)				
A, [HL + C]		2	8	10	A ↔ (HL + C)						

- Notes**
1. When the internal high-speed RAM area is accessed or instruction with no data access
 2. When an area except the internal high-speed RAM area is accessed.
 3. Except "r = A"

Remark One instruction clock cycle is one cycle of the CPU clock (f_{cpu}) selected by the PCC register.

Instruction Group	Mnemonic	Operands	Byte	Clock		Operation	Flag		
				Note 1	Note 2		Z	AC	CY
16-bit data transfer	MOVW	rp, #word	3	6	–	$rp \leftarrow \text{word}$			
		saddrp, #word	4	8	10	$(saddrp) \leftarrow \text{word}$			
		sfrp, #word	4	–	10	$sfrp \leftarrow \text{word}$			
		AX, saddrp	2	6	8	$AX \leftarrow (saddrp)$			
		saddrp, AX	2	6	8	$(saddrp) \leftarrow AX$			
		AX, sfrp	2	–	8	$AX \leftarrow sfrp$			
		sfrp, AX	2	–	8	$sfrp \leftarrow AX$			
		AX, rp Note 3	1	4	–	$AX \leftarrow rp$			
		rp, AX Note 3	1	4	–	$rp \leftarrow AX$			
		AX, !addr16	3	10	12	$AX \leftarrow (\text{addr16})$			
!addr16, AX	3	10	12	$(\text{addr16}) \leftarrow AX$					
XCHW	AX, rp Note 3	1	4	–	$AX \leftrightarrow rp$				
8-bit operation	ADD	A, #byte	2	4	–	$A, CY \leftarrow A + \text{byte}$	x	x	x
		saddr, #byte	3	6	8	$(saddr), CY \leftarrow (saddr) + \text{byte}$	x	x	x
		A, r Note 4	2	4	–	$A, CY \leftarrow A + r$	x	x	x
		r, A	2	4	–	$r, CY \leftarrow r + A$	x	x	x
		A, saddr	2	4	5	$A, CY \leftarrow A + (saddr)$	x	x	x
		A, !addr16	3	8	9	$A, CY \leftarrow A + (\text{addr16})$	x	x	x
		A, [HL]	1	4	5	$A, CY \leftarrow A + (\text{HL})$	x	x	x
		A, [HL + byte]	2	8	9	$A, CY \leftarrow A + (\text{HL} + \text{byte})$	x	x	x
		A, [HL + B]	2	8	9	$A, CY \leftarrow A + (\text{HL} + B)$	x	x	x
		A, [HL + C]	2	8	9	$A, CY \leftarrow A + (\text{HL} + C)$	x	x	x
	ADDC	A, #byte	2	4	–	$A, CY \leftarrow A + \text{byte} + CY$	x	x	x
		saddr, #byte	3	6	8	$(saddr), CY \leftarrow (saddr) + \text{byte} + CY$	x	x	x
		A, r Note 4	2	4	–	$A, CY \leftarrow A + r + CY$	x	x	x
		r, A	2	4	–	$r, CY \leftarrow r + A + CY$	x	x	x
		A, saddr	2	4	5	$A, CY \leftarrow A + (saddr) + CY$	x	x	x
		A, !addr16	3	8	9	$A, CY \leftarrow A + (\text{addr16}) + CY$	x	x	x
		A, [HL]	1	4	5	$A, CY \leftarrow A + (\text{HL}) + CY$	x	x	x
		A, [HL + byte]	2	8	9	$A, CY \leftarrow A + (\text{HL} + \text{byte}) + CY$	x	x	x
A, [HL + B]	2	8	9	$A, CY \leftarrow A + (\text{HL} + B) + CY$	x	x	x		
A, [HL + C]	2	8	9	$A, CY \leftarrow A + (\text{HL} + C) + CY$	x	x	x		

- Notes**
1. When the internal high-speed RAM area is accessed or instruction with no data access
 2. When an area except the internal high-speed RAM area is accessed
 3. Only when rp = BC, DE or HL
 4. Except "r = A"

Remark One instruction clock cycle is one cycle of the CPU clock (f_{cpu}) selected by the PCC register.

Instruction Group	Mnemonic	Operands	Byte	Clock		Operation	Flag		
				Note 1	Note 2		Z	AC	CY
8-bit operation	SUB	A, #byte	2	4	–	A, CY ← A – byte	×	×	×
		saddr, #byte	3	6	8	(saddr), CY ← (saddr) – byte	×	×	×
		A, r Note 3	2	4	–	A, CY ← A – r	×	×	×
		r, A	2	4	–	r, CY ← r – A	×	×	×
		A, saddr	2	4	5	A, CY ← A – (saddr)	×	×	×
		A, !addr16	3	8	9	A, CY ← A – (addr16)	×	×	×
		A, [HL]	1	4	5	A, CY ← A – (HL)	×	×	×
		A, [HL + byte]	2	8	9	A, CY ← A – (HL + byte)	×	×	×
		A, [HL + B]	2	8	9	A, CY ← A – (HL + B)	×	×	×
	A, [HL + C]	2	8	9	A, CY ← A – (HL + C)	×	×	×	
	SUBC	A, #byte	2	4	–	A, CY ← A – byte – CY	×	×	×
		saddr, #byte	3	6	8	(saddr), CY ← (saddr) – byte – CY	×	×	×
		A, r Note 3	2	4	–	A, CY ← A – r – CY	×	×	×
		r, A	2	4	–	r, CY ← r – A – CY	×	×	×
		A, saddr	2	4	5	A, CY ← A – (saddr) – CY	×	×	×
		A, !addr16	3	8	9	A, CY ← A – (addr16) – CY	×	×	×
		A, [HL]	1	4	5	A, CY ← A – (HL) – CY	×	×	×
		A, [HL + byte]	2	8	9	A, CY ← A – (HL + byte) – CY	×	×	×
		A, [HL + B]	2	8	9	A, CY ← A – (HL + B) – CY	×	×	×
	A, [HL + C]	2	8	9	A, CY ← A – (HL + C) – CY	×	×	×	
	AND	A, #byte	2	4	–	A ← A ∧ byte	×		
		saddr, #byte	3	6	8	(saddr) ← (saddr) ∧ byte	×		
		A, r Note 3	2	4	–	A ← A ∧ r	×		
		r, A	2	4	–	r ← r ∧ A	×		
		A, saddr	2	4	5	A ← A ∧ (saddr)	×		
		A, !addr16	3	8	9	A ← A ∧ (addr16)	×		
		A, [HL]	1	4	5	A ← A ∧ (HL)	×		
A, [HL + byte]		2	8	9	A ← A ∧ (HL + byte)	×			
A, [HL + B]		2	8	9	A ← A ∧ (HL + B)	×			
A, [HL + C]	2	8	9	A ← A ∧ (HL + C)	×				

- Notes**
1. When the internal high-speed RAM area is accessed or instruction with no data access
 2. When an area except the internal high-speed RAM area is accessed
 3. Except "r = A"

Remark One instruction clock cycle is one cycle of the CPU clock (f_{CPU}) selected by the PCC register.

Instruction Group	Mnemonic	Operands	Byte	Clock		Operation	Flag		
				Note 1	Note 2		Z	AC	CY
8-bit operation	OR	A, #byte	2	4	–	$A \leftarrow A \vee \text{byte}$		x	
		saddr, #byte	3	6	8	$(\text{saddr}) \leftarrow (\text{saddr}) \vee \text{byte}$		x	
		A, r Note 3	2	4	–	$A \leftarrow A \vee r$		x	
		r, A	2	4	–	$r \leftarrow r \vee A$		x	
		A, saddr	2	4	5	$A \leftarrow A \vee (\text{saddr})$		x	
		A, !addr16	3	8	9	$A \leftarrow A \vee (\text{addr16})$		x	
		A, [HL]	1	4	5	$A \leftarrow A \vee (\text{HL})$		x	
		A, [HL + byte]	2	8	9	$A \leftarrow A \vee (\text{HL} + \text{byte})$		x	
		A, [HL + B]	2	8	9	$A \leftarrow A \vee (\text{HL} + B)$		x	
		A, [HL + C]	2	8	9	$A \leftarrow A \vee (\text{HL} + C)$		x	
	XOR	A, #byte	2	4	–	$A \leftarrow A \nabla \text{byte}$		x	
		saddr, #byte	3	6	8	$(\text{saddr}) \leftarrow (\text{saddr}) \nabla \text{byte}$		x	
		A, r Note 3	2	4	–	$A \leftarrow A \nabla r$		x	
		r, A	2	4	–	$r \leftarrow r \nabla A$		x	
		A, saddr	2	4	5	$A \leftarrow A \nabla (\text{saddr})$		x	
		A, !addr16	3	8	9	$A \leftarrow A \nabla (\text{addr16})$		x	
		A, [HL]	1	4	5	$A \leftarrow A \nabla (\text{HL})$		x	
		A, [HL + byte]	2	8	9	$A \leftarrow A \nabla (\text{HL} + \text{byte})$		x	
		A, [HL + B]	2	8	9	$A \leftarrow A \nabla (\text{HL} + B)$		x	
		A, [HL + C]	2	8	9	$A \leftarrow A \nabla (\text{HL} + C)$		x	
	CMP	A, #byte	2	4	–	$A - \text{byte}$	x	x	x
		saddr, #byte	3	6	8	$(\text{saddr}) - \text{byte}$	x	x	x
		A, r Note 3	2	4	–	$A - r$	x	x	x
		r, A	2	4	–	$r - A$	x	x	x
		A, saddr	2	4	5	$A - (\text{saddr})$	x	x	x
		A, !addr16	3	8	9	$A - (\text{addr16})$	x	x	x
		A, [HL]	1	4	5	$A - (\text{HL})$	x	x	x
A, [HL + byte]		2	8	9	$A - (\text{HL} + \text{byte})$	x	x	x	
A, [HL + B]		2	8	9	$A - (\text{HL} + B)$	x	x	x	
A, [HL + C]		2	8	9	$A - (\text{HL} + C)$	x	x	x	

Notes 1. When the internal high-speed RAM area is accessed or instruction with no data access

2. When an area except the internal high-speed RAM area is accessed

3. Except "r = A"

Remark One instruction clock cycle is one cycle of the CPU clock (f_{CPU}) selected by the PCC register.

Instruction Group	Mnemonic	Operands	Byte	Clock		Operation	Flag		
				Note 1	Note 2		Z	AC	CY
16-bit operation	ADDW	AX, #word	3	6	–	AX, CY ← AX + word	×	×	×
	SUBW	AX, #word	3	6	–	AX, CY ← AX – word	×	×	×
	CMPW	AX, #word	3	6	–	AX – word	×	×	×
Multiply/divide	MULU	X	2	16	–	AX ← A × X			
	DIVUW	C	2	25	–	AX (Quotient), C (Remainder) ← AX ÷ C			
Increment/decrement	INC	r	1	2	–	r ← r + 1	×	×	
		saddr	2	4	6	(saddr) ← (saddr) + 1	×	×	
	DEC	r	1	2	–	r ← r – 1	×	×	
		saddr	2	4	6	(saddr) ← (saddr) – 1	×	×	
	INCW	rp	1	4	–	rp ← rp + 1			
	DECW	rp	1	4	–	rp ← rp – 1			
Rotate	ROR	A, 1	1	2	–	(CY, A ₇ ← A ₀ , A _{m-1} ← A _m) × 1 time			×
	ROL	A, 1	1	2	–	(CY, A ₀ ← A ₇ , A _{m+1} ← A _m) × 1 time			×
	RORC	A, 1	1	2	–	(CY ← A ₀ , A ₇ ← CY, A _{m-1} ← A _m) × 1 time			×
	ROLC	A, 1	1	2	–	(CY ← A ₇ , A ₀ ← CY, A _{m+1} ← A _m) × 1 time			×
	ROR4	[HL]	2	10	12	A ₃₋₀ ← (HL) ₃₋₀ , (HL) ₇₋₄ ← A ₃₋₀ , (HL) ₃₋₀ ← (HL) ₇₋₄			
	ROL4	[HL]	2	10	12	A ₃₋₀ ← (HL) ₇₋₄ , (HL) ₃₋₀ ← A ₃₋₀ , (HL) ₇₋₄ ← (HL) ₃₋₀			
BCD adjust	ADJBA		2	4	–	Decimal Adjust Accumulator after Addition	×	×	×
	ADJBS		2	4	–	Decimal Adjust Accumulator after Subtract	×	×	×
Bit manipulate	MOV1	CY, saddr.bit	3	6	7	CY ← (saddr.bit)			×
		CY, sfr.bit	3	–	7	CY ← sfr.bit			×
		CY, A.bit	2	4	–	CY ← A.bit			×
		CY, PSW.bit	3	–	7	CY ← PSW.bit			×
		CY, [HL].bit	2	6	7	CY ← (HL).bit			×
		saddr.bit, CY	3	6	8	(saddr.bit) ← CY			
		sfr.bit, CY	3	–	8	sfr.bit ← CY			
		A.bit, CY	2	4	–	A.bit ← CY			
		PSW.bit, CY	3	–	8	PSW.bit ← CY	×	×	
		[HL].bit, CY	2	6	8	(HL).bit ← CY			

- Notes**
1. When the internal high-speed RAM area is accessed or instruction with no data access
 2. When an area except the internal high-speed RAM area is accessed

Remark One instruction clock cycle is one cycle of the CPU clock (f_{cpu}) selected by the PCC register.

Instruction Group	Mnemonic	Operands	Byte	Clock		Operation	Flag		
				Note 1	Note 2		Z	AC	CY
Bit manipulate	AND1	CY, saddr.bit	3	6	7	$CY \leftarrow CY \wedge (\text{saddr.bit})$			×
		CY, sfr.bit	3	–	7	$CY \leftarrow CY \wedge \text{sfr.bit}$			×
		CY, A.bit	2	4	–	$CY \leftarrow CY \wedge A.\text{bit}$			×
		CY, PSW.bit	3	–	7	$CY \leftarrow CY \wedge \text{PSW.bit}$			×
		CY, [HL].bit	2	6	7	$CY \leftarrow CY \wedge (\text{HL}).\text{bit}$			×
	OR1	CY, saddr.bit	3	6	7	$CY \leftarrow CY \vee (\text{saddr.bit})$			×
		CY, sfr.bit	3	–	7	$CY \leftarrow CY \vee \text{sfr.bit}$			×
		CY, A.bit	2	4	–	$CY \leftarrow CY \vee A.\text{bit}$			×
		CY, PSW.bit	3	–	7	$CY \leftarrow CY \vee \text{PSW.bit}$			×
		CY, [HL].bit	2	6	7	$CY \leftarrow CY \vee (\text{HL}).\text{bit}$			×
	XOR1	CY, saddr.bit	3	6	7	$CY \leftarrow CY \oplus (\text{saddr.bit})$			×
		CY, sfr.bit	3	–	7	$CY \leftarrow CY \oplus \text{sfr.bit}$			×
		CY, A.bit	2	4	–	$CY \leftarrow CY \oplus A.\text{bit}$			×
		CY, PSW.bit	3	–	7	$CY \leftarrow CY \oplus \text{PSW.bit}$			×
		CY, [HL].bit	2	6	7	$CY \leftarrow CY \oplus (\text{HL}).\text{bit}$			×
	SET1	saddr.bit	2	4	6	$(\text{saddr.bit}) \leftarrow 1$			
		sfr.bit	3	–	8	$\text{sfr.bit} \leftarrow 1$			
		A.bit	2	4	–	$A.\text{bit} \leftarrow 1$			
		PSW.bit	2	–	6	$\text{PSW.bit} \leftarrow 1$	×	×	×
		[HL].bit	2	6	8	$(\text{HL}).\text{bit} \leftarrow 1$			
	CLR1	saddr.bit	2	4	6	$(\text{saddr.bit}) \leftarrow 0$			
		sfr.bit	3	–	8	$\text{sfr.bit} \leftarrow 0$			
		A.bit	2	4	–	$A.\text{bit} \leftarrow 0$			
		PSW.bit	2	–	6	$\text{PSW.bit} \leftarrow 0$	×	×	×
		[HL].bit	2	6	8	$(\text{HL}).\text{bit} \leftarrow 0$			
	SET1	CY	1	2	–	$CY \leftarrow 1$			1
	CLR1	CY	1	2	–	$CY \leftarrow 0$			0
	NOT1	CY	1	2	–	$CY \leftarrow \overline{CY}$			×

- Notes**
1. When the internal high-speed RAM area is accessed or instruction with no data access
 2. When an area except the internal high-speed RAM area is accessed

Remark One instruction clock cycle is one cycle of the CPU clock (f_{cpu}) selected by the PCC register.

Instruction Group	Mnemonic	Operands	Byte	Clock		Operation	Flag		
				Note 1	Note 2		Z	AC	CY
Call/return	CALL	!addr16	3	7	-	$(SP - 1) \leftarrow (PC + 3)_H, (SP - 2) \leftarrow (PC + 3)_L,$ $PC \leftarrow \text{addr16}, SP \leftarrow SP - 2$			
	CALLF	!addr11	2	5	-	$(SP - 1) \leftarrow (PC + 2)_H, (SP - 2) \leftarrow (PC + 2)_L,$ $PC_{15-11} \leftarrow 00001, PC_{10-0} \leftarrow \text{addr11},$ $SP \leftarrow SP - 2$			
	CALLT	[addr5]	1	6	-	$(SP - 1) \leftarrow (PC + 1)_H, (SP - 2) \leftarrow (PC + 1)_L,$ $PC_H \leftarrow (00000000, \text{addr5} + 1),$ $PC_L \leftarrow (00000000, \text{addr5}),$ $SP \leftarrow SP - 2$			
	BRK		1	6	-	$(SP - 1) \leftarrow PSW, (SP - 2) \leftarrow (PC + 1)_H,$ $(SP - 3) \leftarrow (PC + 1)_L, PC_H \leftarrow (003FH),$ $PC_L \leftarrow (003EH), SP \leftarrow SP - 3, IE \leftarrow 0$			
	RET		1	6	-	$PC_H \leftarrow (SP + 1), PC_L \leftarrow (SP),$ $SP \leftarrow SP + 2$			
	RETI		1	6	-	$PC_H \leftarrow (SP + 1), PC_L \leftarrow (SP),$ $PSW \leftarrow (SP + 2), SP \leftarrow SP + 3,$ $NMIS \leftarrow 0$	R	R	R
	RETB		1	6	-	$PC_H \leftarrow (SP + 1), PC_L \leftarrow (SP),$ $PSW \leftarrow (SP + 2), SP \leftarrow SP + 3$	R	R	R
Stack manipulate	PUSH	PSW	1	2	-	$(SP - 1) \leftarrow PSW, SP \leftarrow SP - 1$			
		rp	1	4	-	$(SP - 1) \leftarrow rp_H, (SP - 2) \leftarrow rp_L,$ $SP \leftarrow SP - 2$			
	POP	PSW	1	2	-	$PSW \leftarrow (SP), SP \leftarrow SP + 1$	R	R	R
		rp	1	4	-	$rp_H \leftarrow (SP + 1), rp_L \leftarrow (SP),$ $SP \leftarrow SP + 2$			
	MOVW	SP, #word	4	-	10	$SP \leftarrow \text{word}$			
		SP, AX	2	-	8	$SP \leftarrow AX$			
AX, SP		2	-	8	$AX \leftarrow SP$				
Unconditional branch	BR	!addr16	3	6	-	$PC \leftarrow \text{addr16}$			
		\$addr16	2	6	-	$PC \leftarrow PC + 2 + \text{jdisp8}$			
		AX	2	8	-	$PC_H \leftarrow A, PC_L \leftarrow X$			
Conditional branch	BC	\$addr16	2	6	-	$PC \leftarrow PC + 2 + \text{jdisp8}$ if CY = 1			
	BNC	\$addr16	2	6	-	$PC \leftarrow PC + 2 + \text{jdisp8}$ if CY = 0			
	BZ	\$addr16	2	6	-	$PC \leftarrow PC + 2 + \text{jdisp8}$ if Z = 1			
	BNZ	\$addr16	2	6	-	$PC \leftarrow PC + 2 + \text{jdisp8}$ if Z = 0			

- Notes**
1. When the internal high-speed RAM area is accessed or instruction with no data access
 2. When an area except the internal high-speed RAM area is accessed

Remark One instruction clock cycle is one cycle of the CPU clock (f_{cpu}) selected by the PCC register.

Instruction Group	Mnemonic	Operands	Byte	Clock		Operation	Flag		
				Note 1	Note 2		Z	AC	CY
Conditional branch	BT	saddr.bit, \$addr16	3	8	9	PC ← PC + 3 + jdisp8 if(saddr.bit) = 1			
		sfr.bit, \$addr16	4	–	11	PC ← PC + 4 + jdisp8 if sfr.bit = 1			
		A.bit, \$addr16	3	8	–	PC ← PC + 3 + jdisp8 if A.bit = 1			
		PSW.bit, \$addr16	3	–	9	PC ← PC + 3 + jdisp8 if PSW.bit = 1			
		[HL].bit, \$addr16	3	10	11	PC ← PC + 3 + jdisp8 if (HL).bit = 1			
	BF	saddr.bit, \$addr16	4	10	11	PC ← PC + 4 + jdisp8 if(saddr.bit) = 0			
		sfr.bit, \$addr16	4	–	11	PC ← PC + 4 + jdisp8 if sfr.bit = 0			
		A.bit, \$addr16	3	8	–	PC ← PC + 3 + jdisp8 if A.bit = 0			
		PSW.bit, \$addr16	4	–	11	PC ← PC + 4 + jdisp8 if PSW. bit = 0			
		[HL].bit, \$addr16	3	10	11	PC ← PC + 3 + jdisp8 if (HL).bit = 0			
	BTCLR	saddr.bit, \$addr16	4	10	12	PC ← PC + 4 + jdisp8 if(saddr.bit) = 1 then reset(saddr.bit)			
		sfr.bit, \$addr16	4	–	12	PC ← PC + 4 + jdisp8 if sfr.bit = 1 then reset sfr.bit			
		A.bit, \$addr16	3	8	–	PC ← PC + 3 + jdisp8 if A.bit = 1 then reset A.bit			
		PSW.bit, \$addr16	4	–	12	PC ← PC + 4 + jdisp8 if PSW.bit = 1 then reset PSW.bit	×	×	×
		[HL].bit, \$addr16	3	10	12	PC ← PC + 3 + jdisp8 if (HL).bit = 1 then reset (HL).bit			
DBNZ	B, \$addr16	2	6	–	B ← B – 1, then PC ← PC + 2 + jdisp8 if B ≠ 0				
	C, \$addr16	2	6	–	C ← C – 1, then PC ← PC + 2 + jdisp8 if C ≠ 0				
	saddr. \$addr16	3	8	10	(saddr) ← (saddr) – 1, then PC ← PC + 3 + jdisp8 if(saddr) ≠ 0				
CPU control	SEL	RBn	2	4	–	RBS1, 0 ← n			
	NOP		1	2	–	No Operation			
	EI		2	–	6	IE ← 1(Enable Interrupt)			
	DI		2	–	6	IE ← 0(Disable Interrupt)			
	HALT		2	6	–	Set HALT Mode			
	STOP		2	6	–	Set STOP Mode			

- Notes**
1. When the internal high-speed RAM area is accessed or instruction with no data access
 2. When an area except the internal high-speed RAM area is accessed

Remark One instruction clock cycle is one cycle of the CPU clock (f_{cpu}) selected by the PCC register.

23.3 Instructions Listed by Addressing Type

(1) 8-bit instructions

MOV, XCH, ADD, ADDC, SUB, SUBC, AND, OR, XOR, CMP, MULU, DIVUW, INC, DEC, ROR, ROL, RORC, ROLC, ROR4, ROL4, PUSH, POP, DBNZ

CHAPTER 23 INSTRUCTION SET

Second Operand First Operand	#byte	A	r Note	sfr	saddr	!addr16	PSW	[DE]	[HL]	[HL + byte] [HL + B] [HL + C]	\$addr16	1	None
A	ADD ADDC SUB SUBC AND OR XOR CMP		MOV XCH ADD ADDC SUB SUBC AND OR XOR CMP	MOV XCH	MOV XCH ADD ADDC SUB SUBC AND OR XOR CMP	MOV XCH ADD ADDC SUB SUBC AND OR XOR CMP	MOV	MOV XCH	MOV XCH ADD ADDC SUB SUBC AND OR XOR CMP	MOV XCH ADD ADDC SUB SUBC AND OR XOR CMP		ROR ROL RORC ROL4	
r	MOV	MOV ADD ADDC SUB SUBC AND OR XOR CMP											INC DEC
r1											DBNZ		
sfr	MOV	MOV											
saddr	MOV ADD ADDC SUB SUBC AND OR XOR CMP	MOV									DBNZ		INC DEC
!addr16		MOV											
PSW	MOV	MOV											PUSH POP
[DE]		MOV											
[HL]		MOV											ROR4 ROL4
[HL + byte] [HL + B] [HL + C]		MOV											
X													MULU
C													DIVUW

Note Except r = A

(2) 16-bit instructions

MOVW, XCHW, ADDW, SUBW, CMPW, PUSH, POP, INCW, DECW

Second Operand 1st Operand	#word	AX	rp ^{Note}	sfrp	saddrp	!addr16	SP	None
AX	ADDW SUBW CMPW		MOVW XCHW	MOVW	MOVW	MOVW	MOVW	
rp	MOVW	MOVW ^{Note}						INCW DECW PUSH POP
sfrp	MOVW	MOVW						
saddrp	MOVW	MOVW						
!addr16		MOVW						
SP	MOVW	MOVW						

Note Only when rp = BC, DE, HL

(3) Bit manipulation instructions

MOV1, AND1, OR1, XOR1, SET1, CLR1, NOT1, BT, BF, BTCLR

Second Operand First Operand	A.bit	sfr.bit	saddr.bit	PSW.bit	[HL].bit	CY	\$addr16	None
A.bit						MOV1	BT BF BTCLR	SET1 CLR1
sfr.bit						MOV1	BT BF BTCLR	SET1 CLR1
saddr.bit						MOV1	BT BF BTCLR	SET1 CLR1
PSW.bit						MOV1	BT BF BTCLR	SET1 CLR1
[HL].bit						MOV1	BT BF BTCLR	SET1 CLR1
CY	MOV1 AND1 OR1 XOR1	MOV1 AND1 OR1 XOR1	MOV1 AND1 OR1 XOR1	MOV1 AND1 OR1 XOR1	MOV1 AND1 OR1 XOR1			SET1 CLR1 NOT1

(4) Call/instructions/branch instructions

CALL, CALLF, CALLT, BR, BC, BNC, BZ, BNZ, BT, BF, BTCLR, DBNZ

Second Operand First Operand	AX	!addr16	!addr11	[addr5]	\$addr16
Basic instruction	BR	CALL BR	CALLF	CALLT	BR BC BNC BZ BNZ
Compound instruction					BT BF BTCLR DBNZ

www.DataSheet4U.com

(5) Other instructions

ADJBA, ADJBS, BRK, RET, RETI, RETB, SEL, NOP, EI, DI, HALT, STOP

[MEMO]

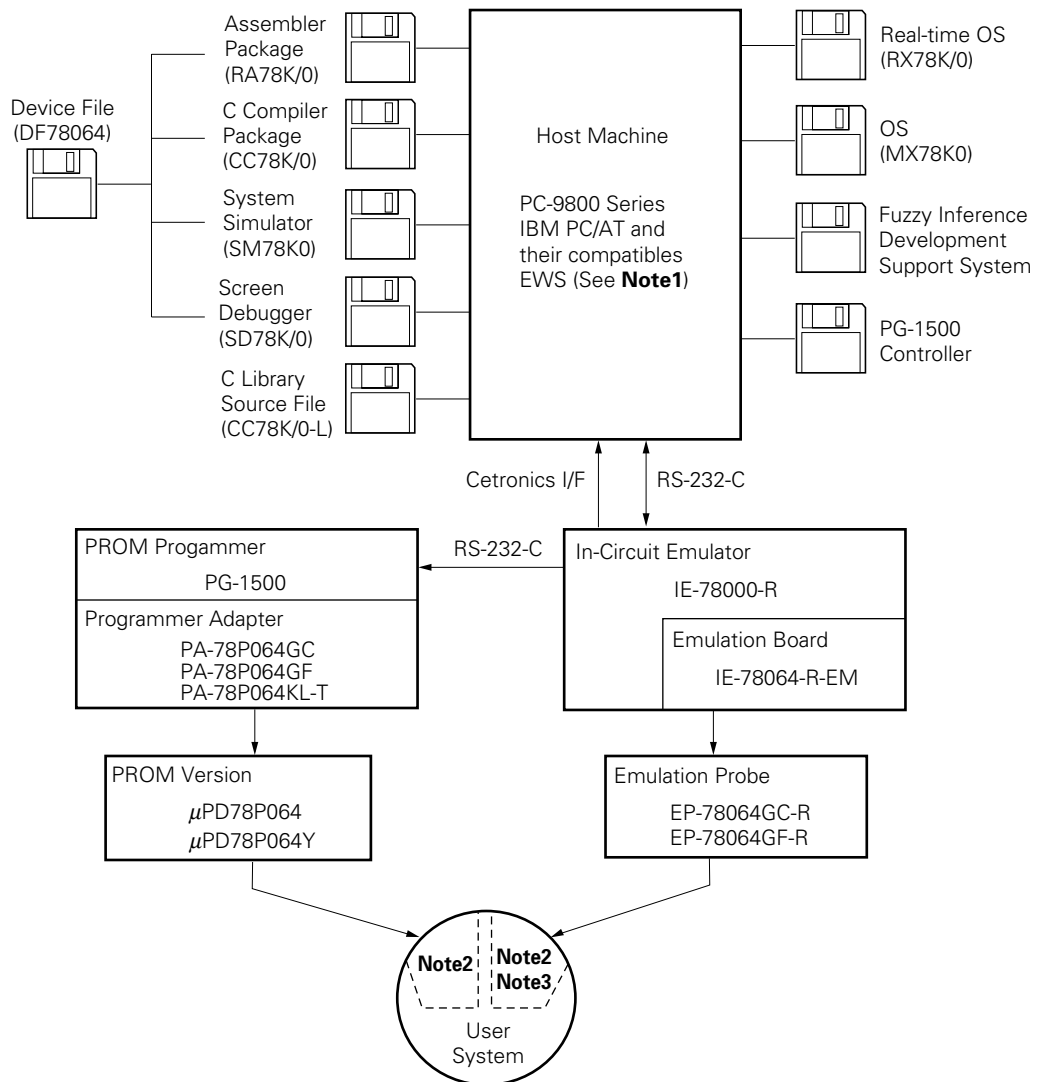
www.DataSheet4U.com

APPENDIX A DEVELOPMENT TOOLS

The following development tools are available for the development of systems which employ the μ PD78064 and 78P064Y subseries. Figure A-1 shows the configuration example of the tools.

Figure A-1. Development Tool Configuration

*



- Notes**
1. Except system simulator, screen debugger, fuzzy inference development support system, and PG-1500 controller.
 2. EV-9200GF-100 (when EP-78064GF-R or 100-pin ceramic WQFN version is used)
 3. EV-9500GC-100 (EP-78064GC-R is used)

Remark Though in this diagram, 3.5-inch floppy disks are shown as software delivery media. Other media are also available.

A.1 Language Processing Software

RA78K/0 (Assembler Package)	This assembler converts a program written in mnemonics into an object code executable with a microcontroller. Further, this assembler is provided with functions capable of automatically creating symbol tables and branch instruction optimization. This data file is used together with DF78064 device file (option). Part Number: μ SxxxxRA78K0
CC78K/0 (C Compiler Package)	This compiler converts a program written in C language into an object code executable with a microcontroller. This data file is used together with RA78K/0 assembler package and DF78064 device file (option). Part Number: μ SxxxxCC78K0
DF78064 (Device File) (See Note)	Device file for the μ PD78064 and 78064Y subseries. This data file is used together with RA78K/0, CC78K/0, SM78K0, and SD78K/0. Part Number: μ SxxxxDF78064
CC78K/0-L (C Compiler Library Source File)	Source program of a function configuring object library included in CC78K/0 C compiler. This file is necessary when customers change the object library in CC78K/0 following their specifications. Part Number: μ SxxxxCC78K0-L

Note This device file can be used for any of RA78K/0, CC78K/0, SM78K0, and SD78K/0.

Remark xxxx of the part number differs depending on the host machine and OS used. Refer to the table below.

μ Sxxxx RA78K0
 μ Sxxxx CC78K0
 μ Sxxxx DF78064
 μ Sxxxx CC78K0-L

xxxx	Host Machine	OS	Medium
5A13	PC-9800 series	MS-DOS	3.5-inch 2HD
5A10		(ver. 3.30 - 5.00A) Note	5-inch 2HD
7B13	IBM PC/AT or compatible machine	Refer to Section A.4.	3.5-inch 2HC
7B10			5-inch 2HC
3H15	HP9000 series 300 TM	HP-UX TM (rel.7.05B)	Cartidge tape (QIC-24)
3P16	HP9000 series 700 TM	HP-UX (rel.9.01)	Digital audio tape (DAT)
3K15	SPARCstation TM	SunOS TM (rel.4.1.1)	Cartidge tape (QIC-24)
3M15	EWS-4800 series (RISC)	EWS-UX/V (rel.4.0)	

*

Note The task swap function is not available with this software though the function is provided in MS-DOS version 5.0 or later.

A.2 PROM Programming Tools

Hardware	PG-1500	This is a PROM programmer capable of programming the single-chip microcontroller incorporating PROM by manipulating from the stand-alone or host machine through connection of an optional PROM programmer adapter and attached board. It can also program representative PROMs ranging from 256K bits to 4M bits.			
	PA-78P064GC PA-78P064GF PA-78P064KL-T	PROM programmer adapter for the μ PD78P064 and 78P064Y. Used connected to the PG-1500. PA-78P064GC : 100-pin plastic QFP (14 x 14 mm) PA-78P064GF : 100-pin plastic QFP (14 x 20 mm) PA-78P064KL-T : 100-pin ceramic WQFN (14 x 20 mm)			
Software	PG-1500 Controller	The PG-1500 is controlled in the host machine through connection with the host machine and PG-1500 via serial and parallel interfaces.			
		Host Machine	OS	Medium	Part Number (Product Name)
		PC-9800 series	MS-DOS Ver.3.30 to Ver.5.00A Note	3.5-inch 2HD	μ S5A13PG1500
				5-inch 2HD	μ S5A10PG1500
		IBM PC/AT or compatibles	Refer to Section A.4.	3.5-inch 2HC	μ S7B13PG1500
5-inch 2HC	μ S7B10PG1500				

Note The task swap function is not available with this software though the function is provided in MS-DOS version 5.0 or later.

A.3 Debugging Tool

A.3.1 Hardware

IE-78000-R (In-circuit emulator)	This in-circuit emulator helps users in debugging hardware and software of an application system that includes a 78K/0 series device. Use this in-circuit emulator in combination with an emulation probe. Connect with the host machine and the PROM programmer for efficient debugging.
IE-78064-R-EM (Emulation board)	This board is for the μ PD78064, 78064Y subseries, and supports voltages from 3 to 5.5 V.
EP-78064GC-R (Emulation probe)	This probe is designed for 100-pin plastic QFP (14 x 14 mm) and can also be used for other devices such as the μ PD78064, 78064Y subseries. This probe set includes a 100-pin conversion adapter EV-9500GC-100 for easier development of user systems.
TGC-100SDW (Conversion adapter)	This adapter connects the EP-78064GC-R to the user system board designed for 100-pin plastic QFP (14 x 14 mm).
EP-78064GF-R (Emulation probe)	This probe is designed for 100-pin plastic QFP (14 x 20 mm) and can also be used for other devices such as the μ PD78064, 78064Y subseries. This probe set includes a 100-pin conversion socket EV-9200GF-100 for easier development of user systems.
EV-9200GF-100 (Conversion socket)	This socket connects the EP-78064GF-R to the user system board designed for a 100-pin plastic QFP (14 x 20 mm).
EV-9900 (Device remover)	This is a jig used to remove the μ PD78P064KL-T and 78P064YKL-T from the EV-9200GF-100.

Remark The EV-9500GC-100 is sold in units of one.
 The EV-9200GF-100 comes in a set of five and is sold in one-unit sets.

A.3.2 Software

SM78K0 (System simulator)	This simulator simulates operations of the target system from a Windows™-installed host computer, enabling debugging in C source level or assembler level. By using SM78K0, logical and performance verification processes can be performed independently of hardware development work without using IE-78000-R in-circuit emulator, which leads to reduction in development workload and improvement in software quality. This system simulator is used together with the DF78064 device file (option). Part Number: μ SxxxxSM78K0
SD78K/0 (Screen debugger)	This debugger is a program which controls the IE-78000-R in-circuit emulator from the host computer. The in-circuit emulator must be connected to the host computer via a serial interface (RS-232-C) cable. This debugger is used together with the DF78064 device file (option). Part Number: μ SxxxxSD78K0
DF78064 (Device File) (See Note)	Device file for the μ PD78064 and 78064Y subseries. This device file is used together with the SM78K0, CC78K/0, RA78K0, and SD78K/0 (option). Part Number: μ SxxxxDF78064

*

Note This device file can be used for any of RA78K/0, CC78K/0, SM78K0, and SD78K/0.

Remark xxxx of the part number differs depending on the host machine and OS used. Refer to the table below.

μ Sxxxx SM78K0

xxxx	Host Machine	OS	Medium
AA13	PC-9800 series	MS-DOS (ver. 3.30 - 5.00A) Note + Windows (ver. 3.0 and 3.1)	3.5-inch 2HD
AA10			5-inch 2HD
AB13	IBM PC/AT or compatible machine (on Japanese Windows)	Refer to Section A.4.	3.5-inch 2HC
AB10			5-inch 2HC
BB13	IBM PC/AT or compatible machine (on English Windows)	Refer to Section A.4.	3.5-inch 2HC
BB10			5-inch 2HC

μ Sxxxx SD78K0

μ Sxxxx DF78064

xxxx	Host Machine	OS	Medium
5A13	PC-9800 series	MS-DOS (ver. 3.30 - 5.00A) Note	3.5-inch 2HD
5A10			5-inch 2HD
7B13	IBM PC/AT or compatible machine	Refer to Section A.4.	3.5-inch 2HC
7B10			5-inch 2HC

Note The task swap function is not available with this software though the function is provided in MS-DOS version 5.0 or later.

* A.4 Operating Systems for IBM PC

The following operating systems are available for IBM PC.

If SM78K0 and FE9200 (see Section B.2 "Fuzzy Inference Development Support System") are to be operated, Windows version 3.0 or 3.1 is also required.

OS	Version
PC DOS	Version 3.3 through 6.3
	J6.1/V through J6.3/V (see Note)
IBM DOS™	J5.02/V (see Note)
MS-DOS	Version 5.0 through 6.2
	5.0/V through 6.2/V (see Note)

Note Supports English versions only.

Caution The task swap function is not available with this software though the function is provided in MS-DOS version 5.0 or later.

System-up method from other in-circuit emulator to IE-78000-R

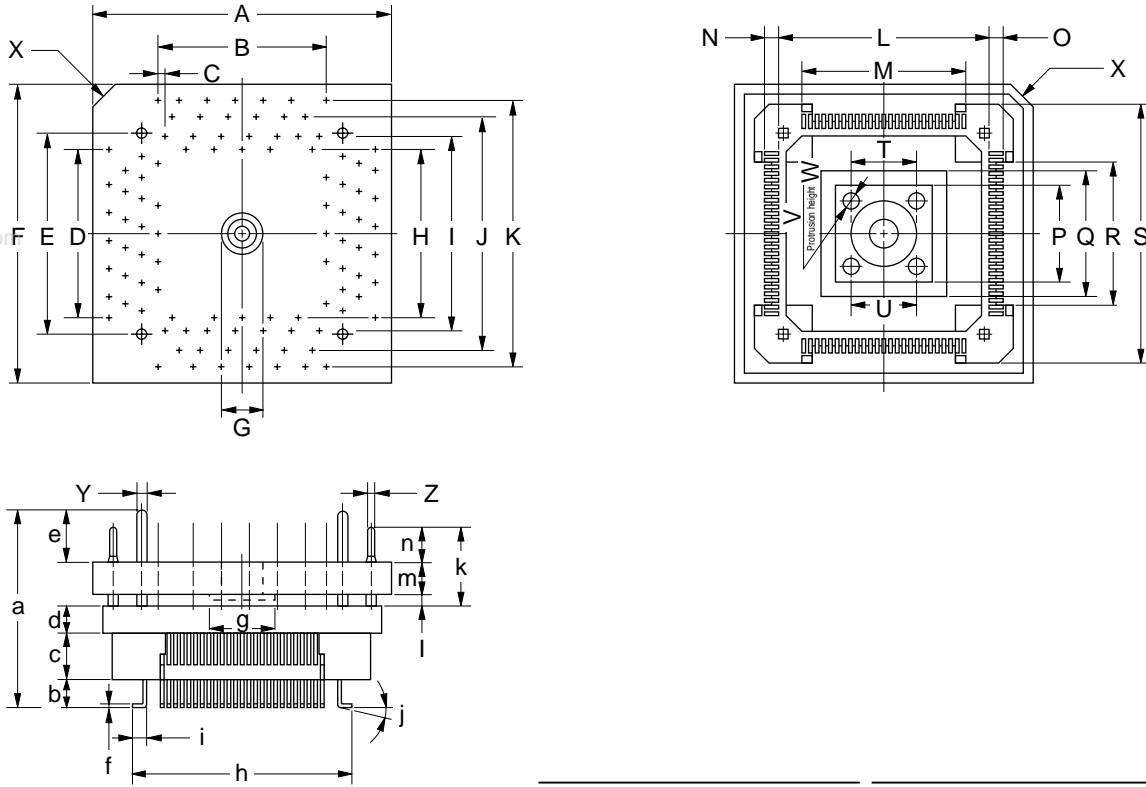
When you already have an in-circuit emulator for the 78K series or the 75X series, you can use that in-circuit emulator as the equivalent of a 78K/0 in-circuit emulator IE-78000-R by replacing the internal break board with the IE-78000-R-BK.

Series Name	In-circuit Emulator Owned	Board to be Purchased
75X Series	IE-75000-R*, IE-75001-R	IE-78000-R-BK
78K/I Series	IE-78130-R, IE-78140-R	
78K/II Series	IE-78230-R*, IE-78230-R-A IE-78240-R*, IE-78240-R-A	
78K/III Series	IE-78320-R*, IE-78327-R IE-78330-R, IE-78350-R	

Remark * : Available for maintenance purpose only.

Drawing for Conversion Adapter (TGC-100SDW)

Figure A-2. TGC-100SDW Drawing (For Reference Only) (Unit: mm)



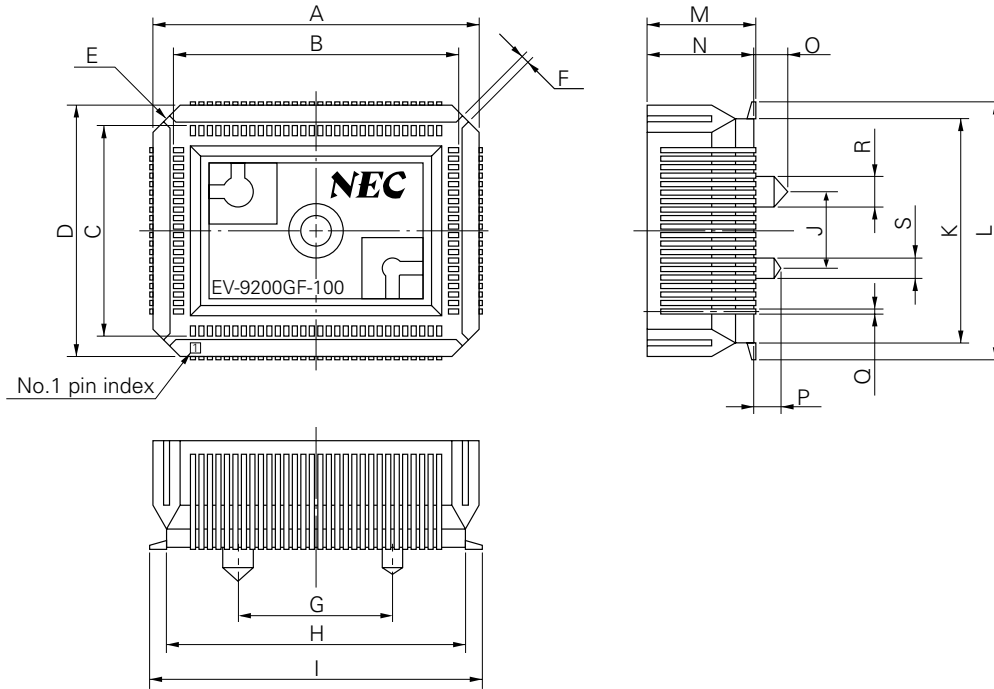
ITEM	MILLIMETERS	INCHES	ITEM	MILLIMETERS	INCHES
A	21.55	0.848	a	14.45	0.569
B	0.5x24=12	0.020x0.945=0.472	b	1.85±0.25	0.073±0.010
C	0.5	0.020	c	3.5	0.138
D	0.5x24=12	0.020x0.945=0.472	d	2.0	0.079
E	15.0	0.591	e	3.9	0.154
F	21.55	0.848	f	0.25	0.010
G	φ3.55	φ0.140	g	φ4.5	φ0.177
H	10.9	0.429	h	16.0	0.630
I	13.3	0.524	i	1.125±0.3	0.044±0.012
J	15.7	0.618	j	0-5°	0.000-0.197°
K	18.1	0.713	k	5.9	0.232
L	13.75	0.541	l	0.8	0.031
M	0.5x24=12.0	0.020x0.945=0.472	m	2.4	0.094
N	1.125±0.3	0.044±0.012	n	2.7	0.106
O	1.125±0.2	0.044±0.008			
P	7.5	0.295	TGC-100SDW-G1E		
Q	10.0	0.394			
R	11.3	0.445			
S	18.1	0.713			
T	φ5.0	φ0.197			
U	5.0	0.197			
V	4-φ1.3	4-φ0.051			
W	1.8	0.071			
X	C 2.0	C 0.079			
Y	φ0.9	φ0.035			
Z	φ0.3	φ0.012			

note: Product by TOKYO ELETECH CORPORATION.

Drawing and Footprint for Conversion Socket (EV-9200GF-100)

Figure A-3. EV-9200GF-100 Drawing (For Reference Only)

Based on EV-9200GF-100
 (1) Package drawing (in mm)

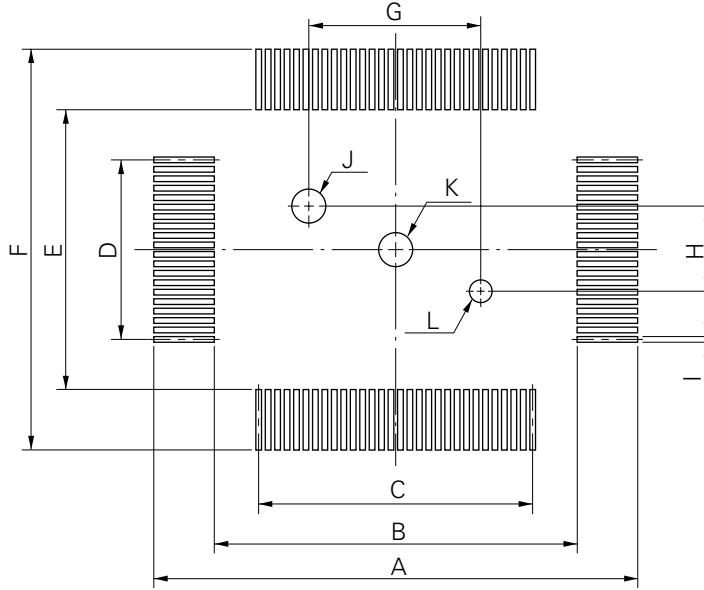


EV-9200GF-100-G0E

ITEM	MILLIMETERS	INCHES
A	24.6	0.969
B	21	0.827
C	15	0.591
D	18.6	0.732
E	4-C 2	4-C 0.079
F	0.8	0.031
G	12.0	0.472
H	22.6	0.89
I	25.3	0.996
J	6.0	0.236
K	16.6	0.654
L	19.3	0.76
M	8.2	0.323
N	8.0	0.315
O	2.5	0.098
P	2.0	0.079
Q	0.35	0.014
R	∅2.3	∅0.091
S	∅1.5	∅0.059

Figure A-4. EV-9200GF-100 Footprint (For Reference Only)

Based on EV-9200GF-100
(2) Pad drawing (in mm)



EV-9200GF-100-P1E

ITEM	MILLIMETERS	INCHES
A	26.3	1.035
B	21.6	0.85
C	$0.65 \pm 0.02 \times 29 = 18.85 \pm 0.05$	$0.026^{+0.001}_{-0.002} \times 1.142 = 0.742^{+0.002}_{-0.002}$
D	$0.65 \pm 0.02 \times 19 = 12.35 \pm 0.05$	$0.026^{+0.001}_{-0.002} \times 0.748 = 0.486^{+0.003}_{-0.002}$
E	15.6	0.614
F	20.3	0.799
G	12 ± 0.05	$0.472^{+0.003}_{-0.002}$
H	6 ± 0.05	$0.236^{+0.003}_{-0.002}$
I	0.35 ± 0.02	$0.014^{+0.001}_{-0.001}$
J	$\phi 2.36 \pm 0.03$	$\phi 0.093^{+0.001}_{-0.002}$
K	$\phi 2.3$	$\phi 0.091$
L	$\phi 1.57 \pm 0.03$	$\phi 0.062^{+0.001}_{-0.002}$

Caution Dimensions of mount pad for EV-9200 and that for target device (QFP) may be different in some parts. For the recommended mount pad dimensions for QFP, refer to "SEMICONDUCTOR DEVICE MOUNTING TECHNOLOGY MANUAL" (C10535E).

APPENDIX B EMBEDDED SOFTWARE

This section describes the embedded software which are provided for the μ PD78064 and 78064Y subseries to allow users to develop and maintain the application program for these subseries.

B.1 Real-time OS (1/2)

RX78K/0 Real-Time OS	<p>RX78K/0 is a real-time OS which is based on the μITRON specification.</p> <p>Supplied with the RX78K/0 nucleus and a tool to prepare multiple information tables (configurator). When using the RX78K/0, the RA78K/0 assembler package (option) is necessary.</p> <p>Part Number: μSxxxxRX78013-$\Delta\Delta\Delta\Delta$</p>
-------------------------	--

Caution When purchasing the RX78K/0, fill in the purchase application form in advance, and sign the Use Approval Contract.

Remark xxxx and $\Delta\Delta\Delta\Delta$ of the part number differs depending on the host machine and OS used. Refer to the table below.

μ SxxxxRX78013- $\Delta\Delta\Delta\Delta$

$\Delta\Delta\Delta\Delta$	Product outline	Max. No. for use in mass production
001	Evaluation object	Do not use for mass production
100K	Mass-production object	100,000
001M		1,000,000
010M		10,000,000
S01	Source program	Source program for mass-production object

xxxx	Host Machine	OS	Medium
5A13	PC-9800 series	MS-DOS	3.5-inch 2HD
5A10		(ver. 3.30 - 5.00A) Note	5-inch 2HD
7B13	IBM PC/AT or compatible machine	Refer to Section A.4.	3.5-inch 2HC
7B10			5-inch 2HC
3H15	HP9000 series 300	HP-UX (rel.7.05B)	Cartridge tape (QIC-24)
3P16	HP9000 series 700	HP-UX (rel.9.01)	Digital tape (DAT)
3K15	SPARCstation	SunOS (rel.4.1.1)	Cartridge tape (QIC-24)
3M15	EWS-4800 series (RISC)	EWS-UX/V (rel.4.0)	

*

Note The task swap function is not available with this software though the function is provided in MS-DOS version 5.0 or later.

✧ B.1 Real-time OS (2/2)

MX78K0 OS	MX78K/0 is an OS for subsets based on the μ ITRON specification. Supplied with the MX78K0 nucleus. This OS manages tasks, events, and time. In task management operation, it controls the execution orders of tasks, and switches processing to the task to be executed next.
	Part Number: μ SxxxxMX78K0- $\Delta\Delta\Delta$

Remark xxxx and $\Delta\Delta\Delta$ of the part number differs depending on the host machine and OS used. Refer to the table below.

μ SxxxxMX78K0- $\Delta\Delta\Delta$

$\Delta\Delta\Delta$	Product outline	Remark
001	Evaluation object	Use for preproduction.
xx	Mass-production object	Use for mass-production.
S01	Source program	Available only when purchasing mass-production object

xxxx	Host Machine	OS	Medium
5A13	PC-9800 series	MS-DOS	3.5-inch 2HD
5A10		(ver. 3.30 - 5.00A) Note	5-inch 2HD
7B13	IBM PC/AT or compatible machine	Refer to Section A.4.	3.5-inch 2HC
7B10			5-inch 2HC
3H15	HP9000 series 300	HP-UX (rel.7.05B)	Cartridge tape (QIC-24)
3P16	HP9000 series 700	HP-UX (rel.9.01)	Digital tape (DAT)
3K15	SPARCstation	SunOS (rel.4.1.1)	Cartridge tape (QIC-24)
3M15	EWS-4800 series (RISC)	EWS-UX/V (rel.4.0)	

Note The task swap function is not available with this software though the function is provided in MS-DOS version 5.0 or later.

B.2 Fuzzy Inference Development Support System

FE9000/FE9200 (Fuzzy Knowledge Data Creation tool)	Program supporting input of fuzzy knowledge data (fuzzy rule and membership function), editing (edit), and evaluation (simulation). FE9200 operates on Windows.
	Part number: $\mu SxxxxFE9000$ (PC-9800 series) $\mu SxxxxFE9200$ (IBM PC/AT or compatible machine)
FT9080/FT9085 (Translator)	Program converting fuzzy knowledge data obtained by using fuzzy knowledge data preparation tool to RA78K/0 assembler source program.
	Part number: $\mu SxxxxFT9080$ (PC-9800 series) $\mu SxxxxFT9085$ (IBM PC/AT or compatible machine)
FI78K0 (Fuzzy Inference Module)	Program executing fuzzy inference. Fuzzy inference is executed by linking fuzzy knowledge data converted by translator.
	Part number: $\mu SxxxxFI78K0$ (PC-9800 series, IBM PC/AT or compatible machine)
FD78K0 (Fuzzy Inference Debugger)	Support software evaluating and adjusting fuzzy knowledge data at hardware level by using in-circuit emulator.
	Part number: $\mu SxxxxFD78K0$ (PC-9800 series, IBM PC/AT or compatible machine)

Remark xxxx of the part number differs depending on the host machine and OS used. Refer to the table below.

$\mu SxxxxFE9000$
 $\mu SxxxxFT9080$
 $\mu SxxxxFI78K0$
 $\mu SxxxxFD78K0$

xxxx	Host Machine	OS	Medium
5A13	PC-9800 series	MS-DOS	3.5-inch 2HD
5A10		(ver. 3.30 - 5.00A) ^{Note}	5-inch 2HD

$\mu SxxxxFE9200$
 $\mu SxxxxFT9085$
 $\mu SxxxxFI78K0$
 $\mu SxxxxFD78K0$

xxxx	Host Machine	OS	Medium
7B13	IBM PC/AT	Refer to Section A.4.	3.5-inch 2HC
7B10	or compatible machine		5-inch 2HC

Note The task swap function is not available with this software though the function is provided in MS-DOS version 5.0 or later.

[MEMO]

www.DataSheet4U.com

APPENDIX C REGISTER INDEX

C.1 Register Name Index

[A]

A/D converter input select register (ADIS) ... 224
A/D converter mode register (ADM) ... 222
A/D conversion result register (ADCR) ... 221
Asynchronous serial interface status register (ASIS) ... 345, 354
Asynchronous serial interface mode register (ASIM) ... 343, 351, 353, 366

www.DataSheet4U.com

[B]

Baud rate generator control register (BRGC) ... 346, 355, 367

[C]

Capture/compare control register 0 (CRC0) ... 139
Capture/compare register 00 (CR00) ... 134
Capture/compare register 01 (CR01) ... 134
Clock timer mode control register (TMC2) ... 199
Compare register 10 (CR10) ... 177
Compare register 20 (CR20) ... 177

[E]

8-bit timer mode control register (TMC1) ... 180
8-bit timer output control register (TOC1) ... 181
8-bit timer register 1 (TM1) ... 177
8-bit timer register 2 (TM2) ... 177
External interrupt mode register 0 (INTM0) ... 142, 409
External interrupt mode register 1 (INTM1) ... 225, 409

[I]

Interrupt mask flag register 0H (MK0H) ... 407
Interrupt mask flag register 0L (MK0L) ... 407
Interrupt mask flag register 1L (MK1L) ... 407, 424
Interrupt request flag register 0H (IF0H) ... 406
Interrupt request flag register 0L (IF0L) ... 406
Interrupt request flag register 1L (IF1L) ... 406, 424
Interrupt timing specification register (SINT) ... 248, 266, 284, 301, 311, 321

[K]

Key return mode register (KRM) ... 109, 425

[L]

LCD display control register (LCDC) ... 376

LCD display mode register (LCDM) ... 374

[M]

Memory size switching register (IMS) ... 440

[O]

Oscillation mode select register (OSMS) ... 117

Oscillation stabilization time select register (OSTS) ... 428

www.DataSheet4U.com

[P]

Port 0 (P0) ... 92

Port 1 (P1) ... 94

Port 2 (P2) ... 95, 97

Port 3 (P3) ... 99

Port 7 (P7) ... 100

Port 8 (P8) ... 102

Port 9 (P9) ... 103

Port 10 (P10) ... 104

Port 11 (P11) ... 105

Port mode register 0 (PM0) ... 106

Port mode register 1 (PM1) ... 106

Port mode register 2 (PM2) ... 106

Port mode register 3 (PM3) ... 106, 141, 182, 213, 218

Port mode register 7 (PM7) ... 106

Port mode register 8 (PM8) ... 106

Port mode register 9 (PM9) ... 106

Port mode register 10 (PM10) ... 106

Port mode register 11 (PM11) ... 106

Priority specification flag register 0H (PR0H) ... 408

Priority specification flag register 0L (PR0L) ... 408

Priority specification flag register 1L (PR1L) ... 408

Processor clock control register (PCC) ... 115

Pull-up resistor option register H (PUOH) ... 109

Pull-up resistor option register L (PUOL) ... 109

[R]

Receive buffer register (RXB) ... 341

Receive shift register (RXS) ... 341

[S]

Sampling clock select register (SCS) ... 143, 411
Serial bus interface control register (SBIC) ... 246, 252, 264, 283, 299, 305, 310, 320
Serial I/O shift register 0 (SIO0) ... 240, 294
Serial operating mode register 0 (CSIM0) ... 244, 250, 263, 282, 298, 304, 309, 319
Serial operating mode register 2 (CSIM2) ... 342, 350, 352, 365
16-bit timer mode control register (TMC0) ... 137
16-bit timer output control register (TOC0) ... 140, 147, 149
16-bit timer register (TM0) ... 134
Slave address register (SVA) ... 240, 286, 294
Successive approximation register (SAR) ... 221

www.DataSheet4U.com

[T]

Timer clock select register 0 (TCL0) ... 135, 211
Timer clock select register 1 (TCL1) ... 178
Timer clock select register 2 (TCL2) ... 196, 204, 216
Timer clock select register 3 (TCL3) ... 242, 296
Transmit shift register (TXS) ... 341

[W]

Watchdog timer mode register (WDTM) ... 206

C.2 Register Symbol Index

[A]

ADCR: A/D conversion result register ... 221
 ADIS: A/D converter input select register ... 224
 ADM: A/D converter mode register ... 222
 ASIM: Asynchronous serial interface mode register ... 343, 351, 353, 366
 ASIS: Asynchronous serial interface status register ... 345, 354

[B]

BRGC: Baud rate generator control register ... 346, 355, 367

[C]

CR00: Capture/compare register 00 ... 134
 CR01: Capture/compare register 01 ... 134
 CR10: Compare register 10 ... 177
 CR20: Compare register 20 ... 177
 CRC0: Capture/compare control register 0 ... 139
 CSIM0: Serial operating mode register 0 ... 244, 250, 263, 282, 298, 304, 309, 319
 CSIM2: Serial operating mode register 2 ... 342, 350, 352, 365

[I]

IF0H: Interrupt request flag register 0H ... 406
 IF0L: Interrupt request flag register 0L ... 406
 IF1L: Interrupt request flag register 1L ... 406, 424
 IMS: Memory size switching register ... 440
 INTM0: External interrupt mode register 0 ... 142, 409
 INTM1: External interrupt mode register 1 ... 225, 409

[K]

KRM: Key return mode register ... 109, 425

[L]

LCDC: LCD display control register ... 376
 LCDM: LCD display mode register ... 374

[M]

MK0H: Interrupt mask flag register 0H ... 407
 MK0L: Interrupt mask flag register 0L ... 407
 MK1L: Interrupt mask flag register 1L ... 407, 424

[O]

OSMS: Oscillation mode select register ... 117
 OSTST: Oscillation stabilization time select register ... 428

[P]

P0: Port 0 ... 92
 P1: Port 1 ... 94
 P2: Port 2 ... 95, 97
 P3: Port 3 ... 99
 P7: Port 7 ... 100
 P8: Port 8 ... 102
 P9: Port 9 ... 103
 P10: Port 10 ... 104
 P11: Port 11 ... 105
 PCC: Processor clock control register ... 115
 PM0: Port mode register 0 ... 106
 PM1: Port mode register 1 ... 106
 PM2: Port mode register 2 ... 106
 PM3: Port mode register 3 ... 106, 141, 182, 213, 218
 PM7: Port mode register 7 ... 106
 PM8: Port mode register 8 ... 106
 PM9: Port mode register 9 ... 106
 PM10: Port mode register 10 ... 106
 PM11: Port mode register 11 ... 106
 PR0H: Priority specification flag register 0H ... 408
 PR0L: Priority specification flag register 0L ... 408
 PR1L: Priority specification flag register 1L ... 408
 PUOH: Pull-up resistor option register H ... 109
 PUOL: Pull-up resistor option register L ... 109

[R]

RXB: Receive buffer register ... 341
 RXS: Receive shift register ... 341

[S]

SAR: Successive approximation register ... 221
 SBIC: Serial bus interface control register ... 246, 252, 264, 283, 299, 305, 310, 320
 SCS: Sampling clock select register ... 143, 411
 SINT: Interrupt timing specification register ... 248, 266, 284, 301, 311, 321
 SIO0: Serial I/O shift register 0 ... 240, 294
 SVA: Slave address register ... 240, 286, 294

[T]

TCL0: Timer clock select register 0 ... 135, 211
TCL1: Timer clock select register 1 ... 178
TCL2: Timer clock select register 2 ... 196, 204, 216
TCL3: Timer clock select register 3 ... 242, 296
TM0: 16-bit timer register ... 134
TM1: 8-bit timer register 1 ... 177
TM2: 8-bit timer register 2 ... 177
TMC0: 16-bit timer mode control register ... 137
TMC1: 8-bit timer mode control register ... 180
TMC2: Clock timer mode control register ... 199
TOC0: 16-bit timer output control register ... 140, 147, 149
TOC1: 8-bit timer output control register ... 181
TXS: Transmit shift register ... 341

[W]

WDTM: Watchdog timer mode register ... 206

APPENDIX D REVISION HISTORY

The revision history is shown below. The chapters appearing in the revised-chapter column indicate those of the corresponding edition.

(1/5)

Edition chapter	Major changes	Revised
Second	Development of the μ PD78063 and μ PD78064 has now been completed.	Throughout
	μ PD78P064KL-T: Being planned -> Being developed	
	Operating supply voltage range: 2.7 to 6.0 V -> 2.0 to 6.0 V	Chapter 1
	Input/output circuit type of pins P10/ANI0 to P17/ANI7: 9-B -> 11	Chapter 2
	Recommended connection of unused IC pins (masked-ROM product): "Connect to V _{SS} ." -> "Connect to V _{SS} directly."	
	Figure 5-2 has been added.	Chapter 5
	The wiring diagram of the oscillator has been modified.	
	Table 6-5 has been modified.	Chapter 6
	A note has been added to timer clock selection register 0 format.	
	A caution has been added to 16-bit timer mode control register format.	
	(6) and (7) have been added to Section 6.5 .	
	Tables 8-1 and 8-3 have been modified.	Chapter 8
	A note has been added to timer clock selection register 0 format.	Chapter 10
	A note has been added to A/D converter mode register format.	Chapter 12
	Port mode register 2 (PM2) has been added to Table 13-2 .	Chapter 13
	Serial interface channel 0 block diagram has been modified.	
	Serial operating mode register 0 format has been modified.	
	Serial bus interface control register format has been modified.	
	Interrupt timing specification register format has been modified.	
	Figure 13-7 has been modified.	
	Figures 13-20 and 13-21 have been modified.	
	Table 13-3: "<3> Reception of address signal" has been added as the condition for output of the ready signal.	
	(e) has been added to (10) of Section 13.4.3 .	
	Figure 13-31 has been modified.	

Edition chapter	Major changes	Revised
Second	Serial interface channel 2 block diagram has been modified.	Chapter 14
	Serial operating mode register 2 format has been modified.	
	Asynchronous serial interface mode register format has been modified.	
	Table 14-2 has been modified.	
	(3) has been added to Section 14.4.2 .	
	A note has been added to interrupt request flag register format.	Chapter 16
	A note has been added to interrupt mask flag register format.	
	Table 16-3 has been modified.	
	Figures 16-15 and 16-16 have been modified.	
	Table 17-1 has been modified.	Chapter 17
	A remark has been added to Figure 17-2 .	
	Table 17-3 has been modified.	
	Language Processing Software, Debugging Tools, and Development Tool Configurations have been modified.	Appendix A
	System Upgrade Method to an IE-78000-R System from Other In-Circuit Emulators has been added.	
	Drawing and Footprint for Conversion Socket (EV-9200GF-100) has been added.	
	Appendix B has been added.	Appendix B

www.DataSheet4U.com

Edition chapter	Major changes	Revised	
Third	Development of the μ PD78062GC, μ PD78062GF, μ PD78P064GC, and μ PD78P064GF has already been completed.	Throughout	
	Section 1.6 has been changed.	Chapter 1	
	Section 2.2.22 has been modified.	Chapter 2	
	The cautions given in Sections 4.2.3 and 4.2.5 have been modified.	Chapter 4	
	Table 4-3 has been added.		
	A caution has been added to (2) of Section 5.3 .	Chapter 5	
	Table 5-2 has been modified.		
	A caution has been added to Section 5.6.2 .		
	Timer clock selection register 0 format has been modified.	Chapter 6	
		Chapter 10	
	Tables 6-2 and 6-6 have been modified.	Chapter 6	
	Tables 6-3 and 6-7 have been modified.		
	A caution has been added to (2) of Section 6.3 .		
	Cautions have been added to (3) and (4) of Section 6.4.4 .		
	Figure 6-32 has been modified.		
	Figure 6-34 has been modified.		
	A caution has been added to timer clock selection register 1 format.		
	Table 7-7 has been added.		Chapter 7
	Timer clock selection register 2 format has been modified.		Chapter 8
			Chapter 9
		Chapter 11	
	In Section 12.5 , “ (6) A/D conversion end interrupt request flag (INTAD) ” has been changed to “ (6) Interrupt request flag (ADIF) .” Also, (8) has been deleted.	Chapter 12	
	A note has been deleted from Table 13-1 .	Chapter 13	
	A caution has been added to timer clock selection register 3 format.		
	Serial bus interface control register format has been modified.		
	Figure 13-21 has been modified.		
	Table 14-2 has been modified.		
	(3) has been added to Section 14.4.3 .	Chapter 14	

Edition chapter	Major changes	Revised
Third	The 1/2 bias method has been modified in the LCD drive power supply connection examples (with on-chip split resistor and with external split resistor).	Chapter 15
	The following LCD drive waveform examples have been modified: Static LCD drive waveform examples 2-time-division LCD drive waveform examples (1/2 bias method) 3-time-division LCD drive waveform examples (1/2 bias method) 3-time-division LCD drive waveform examples (1/3 bias method) 4-time-division LCD drive waveform examples (1/3 bias method)	
	Chapter 16 "Interrupt Functions" has been changed to Chapter 16 "Interrupt and Test Functions" . Section 16.5 has been added.	Chapter 16
	A caution relating to be specification of the writing address has been added to Section 19.2 .	Chapter 19
	Sections 20.2 and 20.3 have been deleted.	Chapter 20
	Version of PC DOS: 3.1 -> 3.3 to 5.0 The 3.5-inch 2HC floppy disk format has been added to the supported distribution media for the IBM PC/AT.	Appendix A,B
	Drawing for conversion adapter (EV-9500GC-100) has been added.	Appendix A
	The fuzzy inference development support system has been changed.	Appendix B
	Appendix C of the previous version has been deleted.	—
	Appendix C has been newly added.	Appendix C

www.DataSheet4U.com

Edition chapter	Major changes	Revised
Fourth	μPD78064Y subseries has been added for target devices.	Throughout
	<ul style="list-style-type: none"> • Recommended connections of the following unused pins has been modified. P07/XT1, P110 to P117, V_{PP} • I/O circuit type of the following pins has been modified. P110 to P117 	Chapter 3
	A caution given in Figure 7-4 has been modified and added.	Chapter 7
	A caution given in Figure 7-6 has been modified.	
	Figure 10-1 has been modified.	Chapter 10
	Figure 14-2 has been modified.	Chapter 14
	Section 14.5(7) has been modified and Figure 14-12 has been added.	
	Figure 15-4 has been modified.	
	Figure 15-21 has been modified.	Chapter 15
	Section 15.4.4(c) has been modified.	
	Figure 15-34 has been modified.	
	Figure 17-1 has been modified.	
	Range of baud rate transmit/receive clock generated by main system clock has been changed. 75 bps to 38400 bps -> 75 bps to 76800 bps	Chapter 17
	Table 20-1 has been modified. Description of operation conditions in HALT mode has been separated to those under main system clock operation and sub-system clock operation.	
	Cautions given in Section 20.2.2(1) have been modified.	Chapter 20
	Table 20-3 has been modified. Description of operation conditions in STOP mode has been separated to those under main system clock operation and sub-system clock operation.	
	Description of QTOP microcontroller has been added to Section 22.5 .	Chapter 22
	HP9000 series 700 has been added to the host machine for development tools and embedded software.	Appendix A, B
System simulator (SM78K0) has been added for development tools.	Appendix A	
Section A.4 has been added.		
OS(MX78K0) has been added for embedded software.	Appendix B	

www.DataSheet4U.com

[MEMO]

www.DataSheet4U.com

Facsimile Message

Although NEC has taken all possible steps to ensure that the documentation supplied to our customers is complete, bug free and up-to-date, we readily accept that errors may occur. Despite all the care and precautions we've taken, you may encounter problems in the documentation. Please complete this form whenever you'd like to report errors or suggest improvements to us.

From:

Name

Company

Tel.

FAX

Address

Thank you for your kind support.

North America

NEC Electronics Inc.
Corporate Communications Dept.
Fax: 1-800-729-9288
1-408-588-6130

Hong Kong, Philippines, Oceania

NEC Electronics Hong Kong Ltd.
Fax: +852-2886-9022/9044

Asian Nations except Philippines

NEC Electronics Singapore Pte. Ltd.
Fax: +65-250-3583

Europe

NEC Electronics (Europe) GmbH
Technical Documentation Dept.
Fax: +49-211-6503-274

Korea

NEC Electronics Hong Kong Ltd.
Seoul Branch
Fax: 02-528-4411

Japan

NEC Semiconductor Technical Hotline
Fax: 044-548-7900

South America

NEC do Brasil S.A.
Fax: +55-11-6465-6829

Taiwan

NEC Electronics Taiwan Ltd.
Fax: 02-2719-5951

I would like to report the following error/make the following suggestion:

Document title: _____

Document number: _____ Page number: _____

If possible, please fax the referenced page or drawing.

Document Rating	Excellent	Good	Acceptable	Poor
Clarity	<input type="checkbox"/>	<input type="checkbox"/>	<input type="checkbox"/>	<input type="checkbox"/>
Technical Accuracy	<input type="checkbox"/>	<input type="checkbox"/>	<input type="checkbox"/>	<input type="checkbox"/>
Organization	<input type="checkbox"/>	<input type="checkbox"/>	<input type="checkbox"/>	<input type="checkbox"/>