

## 16/8-BIT SINGLE-CHIP MICROCONTROLLERS

## DESCRIPTION

$\mu$ PD78366A is provided with a high-speed, high-performance CPU and powerful operation functions. Unlike the existing  $\mu$ PD78328,  $\mu$ PD78366A is also provided with a high-resolution PWM signal output function which substantially contributes to improving the performance of the inverter control.

A PROM model,  $\mu$ PD78P368A, is also available.

Detailed functions, etc. are described in the following user's manual. Be sure to read the manual to design systems.

$\mu$ PD78366A User's Manual Hardware: U10205E

$\mu$ PD78356 User's Manual : U12117E

## FEATURES

- Internal 16-bit architecture, external 8-bit data bus
- High-speed processing by pipeline control method and high-speed operating clock
  - Minimum instruction execution time: 125 ns (internal clock: at 16 MHz, external clock: 8 MHz)
- Real-time pulse unit for inverter control
- 10-bit resolution A/D converter: 8 channels
- 8-/9-/10-/12-bit resolution variable PWM signal output function: 2 channels
- Powerful serial interface: 2 channels
- Internal memory:

ROM: none ( $\mu$ PD78365A)

24K bytes ( $\mu$ PD78363A)

32K bytes ( $\mu$ PD78366A)

48K bytes ( $\mu$ PD78368A)

RAM: 768 bytes ( $\mu$ PD78363A)

2K bytes ( $\mu$ PD78365A, 78366A, 78368A)

## APPLICATION EXAMPLES

- Inverter air conditioner
- Factory automation fields, such as industrial robots and machine tools.

## ORDERING INFORMATION

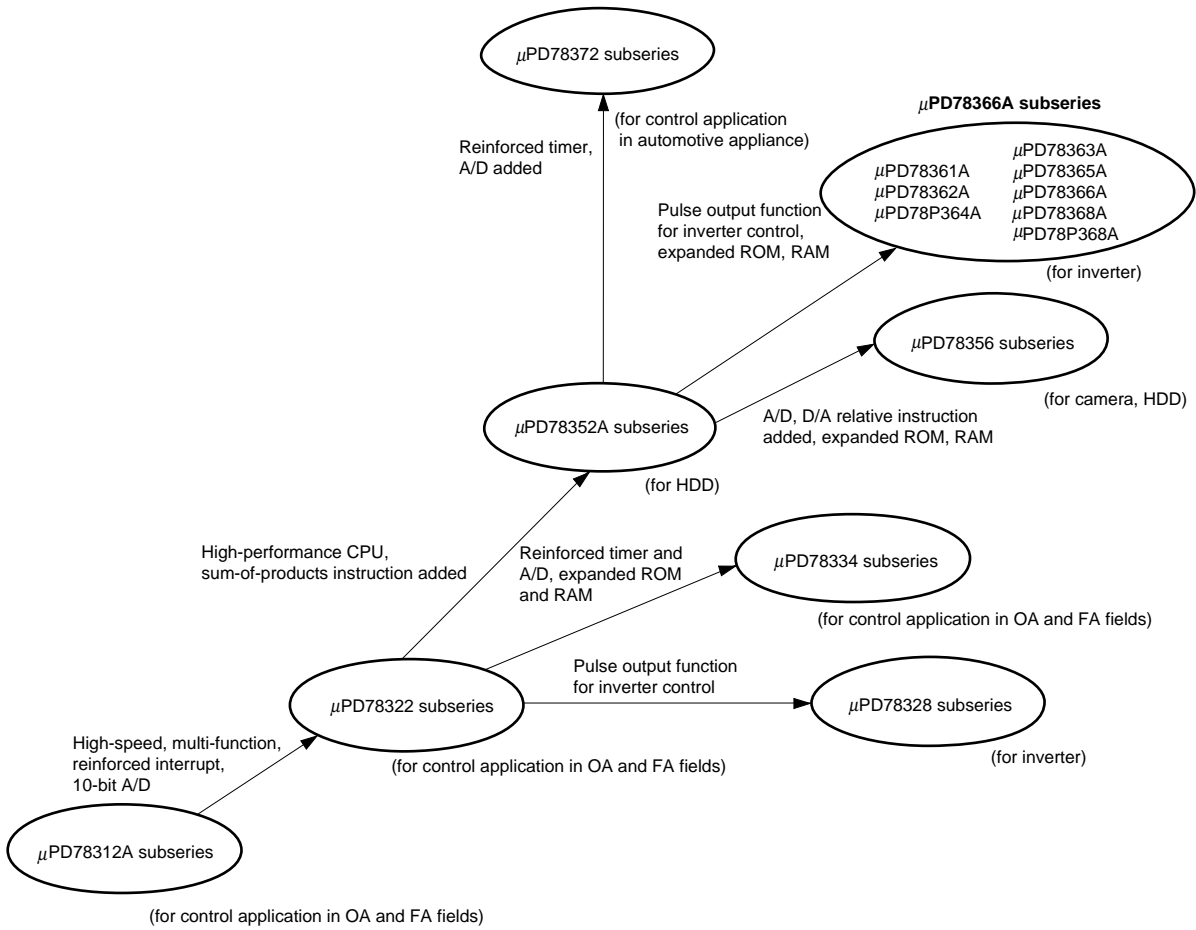
Part Number	Package	Internal ROM
$\mu$ PD78363AGF-xxx-3B9	80-pin plastic QFP (14 × 20 mm)	Mask ROM
$\mu$ PD78365AGF-3B9	80-pin plastic QFP (14 × 20 mm)	None
$\mu$ PD78366AGF-xxx-3B9	80-pin plastic QFP (14 × 20 mm)	Mask ROM
★ $\mu$ PD78368AGF-xxx-3B9	80-pin plastic QFP (14 × 20 mm)	Mask ROM

**Remark** xxx indicates a ROM code suffix.

Unless otherwise specified, the functions and performances of the  $\mu$ PD78366 are described throughout this document.

The information in this document is subject to change without notice.

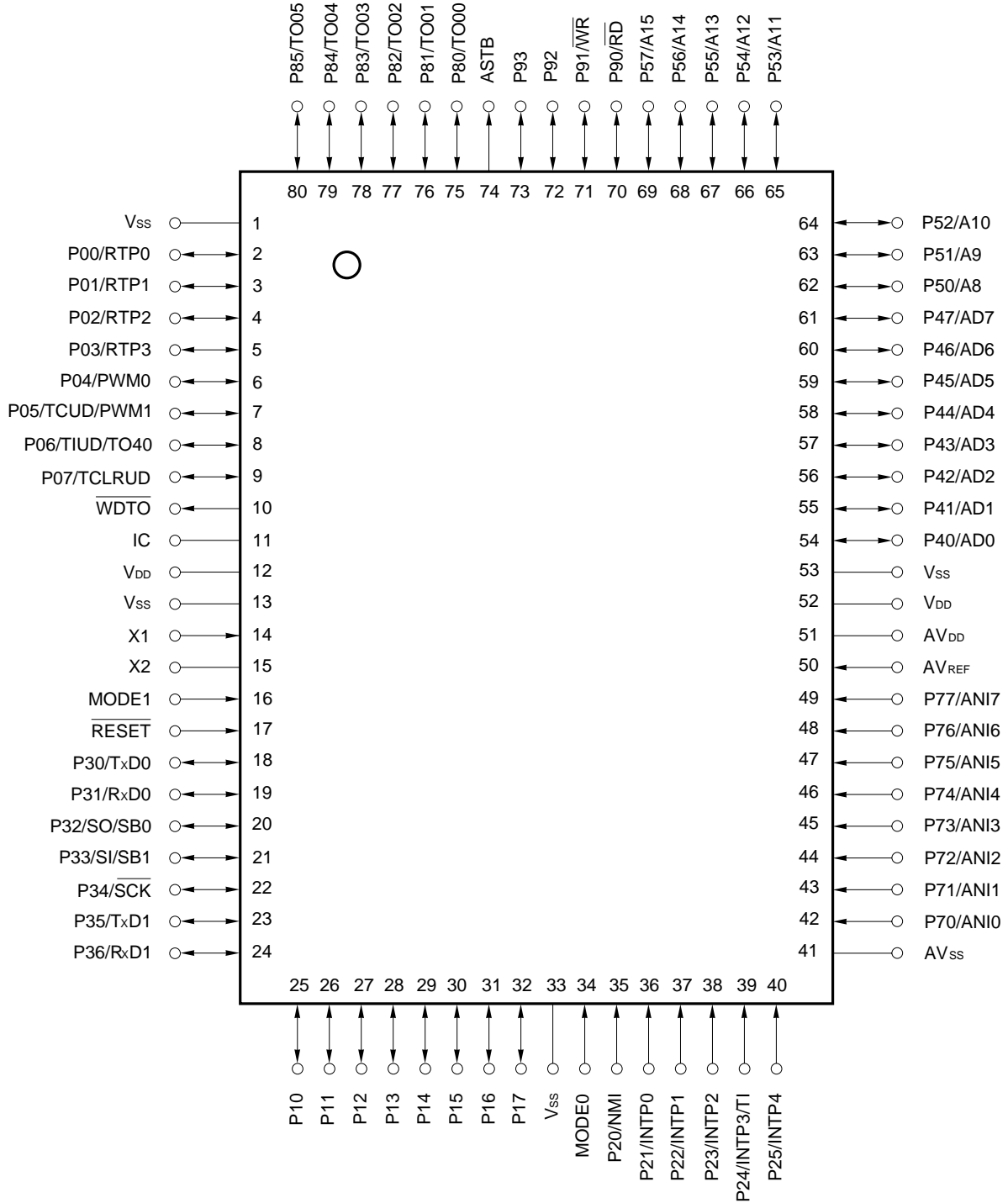
78K/III Series Product Development



**PIN CONFIGURATION (TOP VIEW)**

- 80-pin plastic QFP (14 × 20 mm)

★ μPD78363AGF-xxx-3B9, 78365AGF-3B9, 78366AGF-xxx-3B9, 78368AGF-xxx-3B9



**Caution** Connect the IC pin directly to Vss.

**Remark** xxx indicates a ROM code suffix

P00-P07	: Port0
P10-P17	: Port1
P20-P25	: Port2
P30-P36	: Port3
P40-P47	: Port4
P50-P57	: Port5
P70-P77	: Port7
P80-P85	: Port8
P90-P93	: Port9
RTP0-RTP3	: Real-time Port
NMI	: Nonmaskable Interrupt
INTP0-INTP4	: Interrupt From Peripherals
TO00-TO05, TO04	: Timer Output
TI	: Timer Input
TIUD	: Timer Input Up Down Counter
TCUD	: Timer Control Up Down Counter
TCLRUD	: Timer Clear Up Down Counter
ANI0-ANI7	: Analog Input
TxD0, TxD1	: Transmit Data
RxD0, RxD1	: Receive Data
SI	: Serial Input
SO	: Serial Output
SB0, SB1	: Serial Bus
$\overline{SCK}$	: Serial Clock
PWM0, PWM1	: Pulse Width Modulation Output
WDTO	: Watchdog Timer Output
MODE0, MODE1	: Mode
AD0-AD7	: Address/Data Bus
A8-A15	: Address Bus
ASTB	: Address Strobe
$\overline{RD}$	: Read Strobe
$\overline{WR}$	: Write Strobe
$\overline{RESET}$	: Reset
X1, X2	: Crystal
AV <sub>DD</sub>	: Analog V <sub>DD</sub>
AV <sub>SS</sub>	: Analog V <sub>SS</sub>
AV <sub>REF</sub>	: Analog Reference Voltage
V <sub>DD</sub>	: Power Supply
V <sub>SS</sub>	: Ground
IC	: Internally Connected

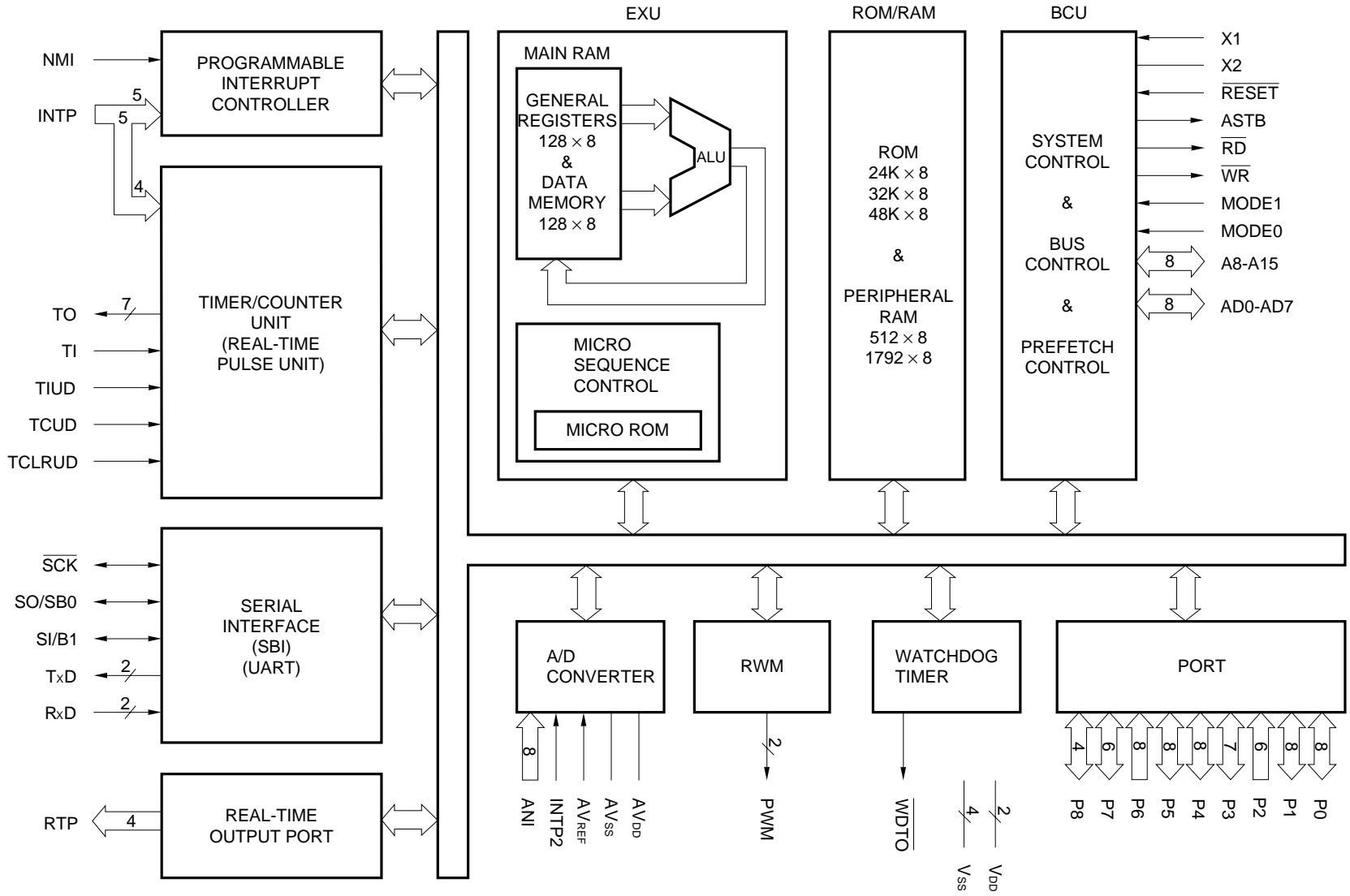
FUNCTIONAL OUTLINE

Item		Product name			
		μPD78363A	μPD78365A	μPD78366A	μPD78368A
Minimum instruction execution time		125 ns (internal clock: 16 MHz, external clock: 8 MHz)			
Internal memory	ROM	24K bytes	None	32K bytes	48K bytes
	RAM	768 bytes	2K bytes		
Memory space		64K bytes (externally expandable)			
General-purpose registers		8 bits × 16 × 8 banks			
Number of basic instructions		115			
Instruction set		<ul style="list-style-type: none"> <li>• 16-bit transfer/operation</li> <li>• Multiplication/division (16 bits × 16 bits, 32 bits ÷ 16 bits)</li> <li>• Bit manipulation</li> <li>• String</li> <li>• Sum-of-products operation (16 bits × 16 bits + 32 bits)</li> <li>• Relative operation</li> </ul>			
I/O lines	Input	14 (of which 8 are shared with analog input)			
	I/O	49	31	49	
Real-time pulse unit		<ul style="list-style-type: none"> <li>• 16-bit timer × 1 10-bit dead time timer × 3 16-bit compare register × 4 2 kinds of output mode can be selected Mode 0, set-reset output: 6 channels Mode 1, buffer output: 6 channels</li> <li>• 16-bit timer × 1 16-bit compare register × 1</li> <li>• 16-bit timer × 1 16-bit capture register × 1 16-bit capture/compare register × 1</li> <li>• 16-bit timer × 1 16-bit capture register × 2 16-bit capture/compare register × 1</li> <li>• 16-bit timer × 1 16-bit compare register × 2 16-bit resolution PWM output: 1 channel</li> </ul>			
Real-time output port		Pulse outputs associated with real-time pulse unit: 4 lines			
PWM unit		8-/9-/10-/12-bit resolution variable PWM output: 2 channels			
A/D converter		10-bit resolution, 8 channels			
Serial interface		Dedicated baud rate generator UART (w/pin selection function): 1 channel Clocked serial interface/SBI: 1 channel			
Interrupt function		<ul style="list-style-type: none"> <li>• External: 6, internal: 14 (of which 2 are multiplexed with external)</li> <li>• 4 priority levels can be specified through software</li> <li>• 3 types of interrupt processing modes selectable (vectored interrupt, macro service, and context switching)</li> </ul>			
Package		80-pin plastic QFP (14 × 20 mm)			
Others		<ul style="list-style-type: none"> <li>• Watchdog timer</li> <li>• Standby function (HALT and STOP modes)</li> </ul>			

**DIFFERENCES BETWEEN μPD78363A, 78365A, 78366A, AND 78368A**

Item		Product name	μPD78363A	μPD78366A	μPD78368A	μPD78365A
Internal ROM	ROM		24K bytes	32K bytes	48K bytes	None
	RAM		786 bytes	2K bytes		
I/O lines	Input		14 (of which 8 are multiplexed with analog input)			
	I/O		49		31	
Port 4 (P40-P47)			Can be set in input or output mode in units of 8 bits. In external memory expansion mode, this port functions as multiplexed address/data bus (AD0-AD7).			Always functions as multiplexed address/data bus (AD0-AD7).
Port 5 (P50-P57)			Can be set in input or output mode in 1-bit units. In external memory expansion mode, this port functions as address bus (A8-A15).			Always functions as address bus (A8-A15)
Port 9 (P90-P93)			Can be set in input or output mode in 1-bit units. In external memory expansion mode, P90 outputs $\overline{RD}$ strobe signal, and P91 outputs $\overline{WR}$ strobe signal.			P90 always functions as $\overline{RD}$ strobe signal output pin, and P91 always functions as $\overline{WR}$ strobe signal output pin. P92 and P93 function as I/O port lines.
Memory expansion mode register (MM)			Sets port 4 in input or output mode in units of 8 bits. In external memory expansion mode, sets memory expansion width of ports 4 and 5.			Always fixed to external memory expansion mode.
Port 5 mode register (PM5)			Sets port 5 in input or output mode in 1-bit units.			None
Setting of MODE0, MODE1			<ul style="list-style-type: none"> <li>In ordinary operation mode: MODE0, 1 = LL</li> <li>In ROM-less mode: MODE0, 1 = HH</li> </ul>			<ul style="list-style-type: none"> <li>Always set as follows: MODE0, 1 = HH</li> </ul>

BLOCK DIAGRAM



**Remark** The internal ROM and RAM capacities differ depending on the product.

**CONTENTS**

- 1. PIN FUNCTIONS ..... 10**
  - 1.1 PORT PINS ..... 10**
  - 1.2 PINS OTHER THAN PORT PINS ..... 11**
  - 1.3 PIN I/O CIRCUITS AND PROCESSING OF UNUSED PINS ..... 13**
  
- 2. CPU ARCHITECTURE ..... 15**
  - 2.1 MEMORY SPACE ..... 15**
  - 2.2 DATA MEMORY ADDRESSING ..... 18**
  - 2.3 PROCESSOR REGISTERS ..... 20**
    - 2.3.1 Control Registers ..... 21
    - 2.3.2 General-Purpose Registers ..... 22
    - 2.3.3 Special Function Registers (SFR) ..... 23
  
- 3. FUNCTIONAL BLOCKS ..... 29**
  - 3.1 EXECUTION UNIT (EXU) ..... 29**
  - 3.2 BUS CONTROL UNIT (BCU) ..... 29**
  - 3.3 ROM/RAM ..... 29**
  - 3.4 PORT FUNCTIONS ..... 30**
  - 3.5 CLOCK GENERATOR CIRCUIT ..... 32**
  - 3.6 REAL-TIME PULSE UNIT (RPU) ..... 34**
  - 3.7 REAL-TIME OUTPUT PORT (RTP) ..... 42**
  - 3.8 A/D CONVERTER ..... 43**
  - 3.9 SERIAL INTERFACE ..... 44**
  - 3.10 PWM UNIT ..... 46**
  - 3.11 WATCHDOG TIMER (WDT) ..... 47**
  
- 4. INTERRUPT FUNCTIONS ..... 48**
  - 4.1 OUTLINE ..... 48**
  - 4.2 MACRO SERVICE ..... 49**
  - 4.3 CONTEXT SWITCHING ..... 52**
    - 4.3.1 Context Switching Function by Interrupt Request ..... 52
    - 4.3.2 Context Switching Function by BRKCS Instruction ..... 53
    - 4.3.3 Restoration from Context Switching ..... 53
  
- 5. EXTERNAL DEVICE EXPANSION FUNCTION ..... 54**
  
- 6. STANDBY FUNCTIONS ..... 55**
  
- 7. RESET FUNCTION ..... 56**
  
- 8. INSTRUCTION SET ..... 57**
  
- 9. EXAMPLE OF SYSTEM CONFIGURATION ..... 71**
  
- 10. ELECTRICAL SPECIFICATIONS ..... 72**



11. PACKAGE DRAWING .....	83
12. RECOMMENDED SOLDERING CONDITIONS .....	84
APPENDIX A. DIFFERENCES BETWEEN $\mu$ PD78366A AND $\mu$ PD78328 .....	85
APPENDIX B. TOOLS .....	86
B.1 DEVELOPMENT TOOLS .....	86
B.2 EMBEDDED SOFTWARE .....	91

1. PIN FUNCTIONS

1.1 PORT PINS

Pin name	I/O	Function	Shared by:
P00-P03	I/O	Port 0. 8-bit I/O port. Can be set in input or output mode in 1-bit units.	RTP0-RTP3
P04			PWM0
P05			TCUD/PWM1
P06			TIUD/TO40
P07			TCLRUD
P10-P17	I/O	Port 1. 8-bit I/O port. Can be set in input or output mode in 1-bit units.	-
P20	Input	Port 2. 6-bit input port.	NMI
P21			INTP0
P22			INTP1
P23			INTP2
P24			INTP3/TI
P25			INTP4
P30	I/O	Port 3. 7-bit I/O port. Can be set in input or output mode in 1-bit units.	TxD0
P31			RxD0
P32			SO/SB0
P33			SI/SB1
P34			$\overline{SCK}$
P35			TxD1
P36			RxD1
P40-P47	I/O	Port 4. 8-bit I/O Port. Can be set in input or output mode in 8-bit units.	AD0-AD7
P50-P57	I/O	Port 5. 8-bit I/O port. Can be set in input or output mode in 1-bit units.	A8-A15
P70-P77	Input	Port 7. 8-bit input port	ANI0-ANI7
P80-P85	I/O	Port 8. 6-bit I/O port. Can be set in input or output mode in 1-bit units.	TO00-TO05
P90	I/O	Port 9. 4-bit I/O port. Can be set in input or output mode in 1-bit units.	$\overline{RD}$
P91			$\overline{WR}$
P92			-
P93			-

1.2 PINS OTHER THAN PORT PINS (1/2)

Pin name	I/O	Function	Shared by:
RTP0-RTP3	Output	Real-time output port that outputs pulses in synchronization with trigger signal from real-time pulse unit.	P00-P03
NMI	Input	Non-maskable interrupt request input.	P20
INTP0		External interrupt request input.	P21
INTP1		P22	
INTP2		P23	
INTP3		P24/TI	
INTP4		P25	
TI	Input	External count clock input to timer 1.	P24/INTP3
TCUD		Count operation selection control signal input to up/down counter (timer 4).	P05/PWM1
TIUD		External count clock input to up/down counter (timer 4).	P06/TO40
TCLRUD		Clear signal input to up/down counter (timer 4).	P07
TO00-TO05	Output	Pulse output from real-time pulse unit.	P80-P85
TO40			P06/TIUD
ANI0-ANI7	Input	Analog input to A/D converter.	P70-P77
TxD0	Output	Serial data output of asynchronous serial interface.	P30
TxD1			P35
RxD0	Input	Serial data input of asynchronous serial interface.	P31
RxD1			P36
SCK	I/O	Serial clock input/output of clocked serial interface.	P34
SI	Input	Serial data input of clocked serial interface in 3-line mode.	P33/SB1
SO	Output	Serial data output of clocked serial interface in 3-line mode.	P32/SB0
SB0	I/O	Serial data input/output of clocked serial interface in SBI mode.	P32/SO
SB1			P33/SI
PWM0	Output	PWM signal output.	P04
PWM1			P05/TCUD
WDTO	Output	Signal output indicating overflow of watchdog timer (generates non-maskable interrupt).	-
AD0-AD7	I/O	Multiplexed address/data bus when memory is externally expanded.	P40-P47
A8-A15		Address bus when memory is externally expanded.	P50-P57
ASTB	Output	Outputs timing signal at which address information output from AD0-AD7 and A8-A15 pins to access external memory is to be latched.	-
RD		Read strobe signal output to external memory.	P90
WR		Write strobe signal output to external memory.	P91

1.2 PINS OTHER THAN PORT PINS (2/2)

Pin name	I/O	Function	Shared by:
MODE0	Input	Control signal input to set operation mode. With μPD78363A, 78366A, and 78368A MODE0 and MODE1 are usually connected to V <sub>SS</sub> . With μPD78365A, MODE0 and MODE1 are always connected to V <sub>DD</sub> .	-
MODE1			
$\overline{\text{RESET}}$	Input	System reset input	-
X1	Input	Crystal oscillator connecting pins for system clock. If a clock is externally supplied, input it to pin X1. Leave pin X2 open.	-
X2	-		
AV <sub>REF</sub>	Input	A/D converter reference voltage input.	-
AV <sub>DD</sub>	-	A/D converter analog power supply.	-
AV <sub>SS</sub>	-	A/D converter GND.	-
V <sub>DD</sub>	-	Positive power supply	-
V <sub>SS</sub>	-	GND	-
IC	-	Internally connected. Connect this pin to V <sub>SS</sub> .	-

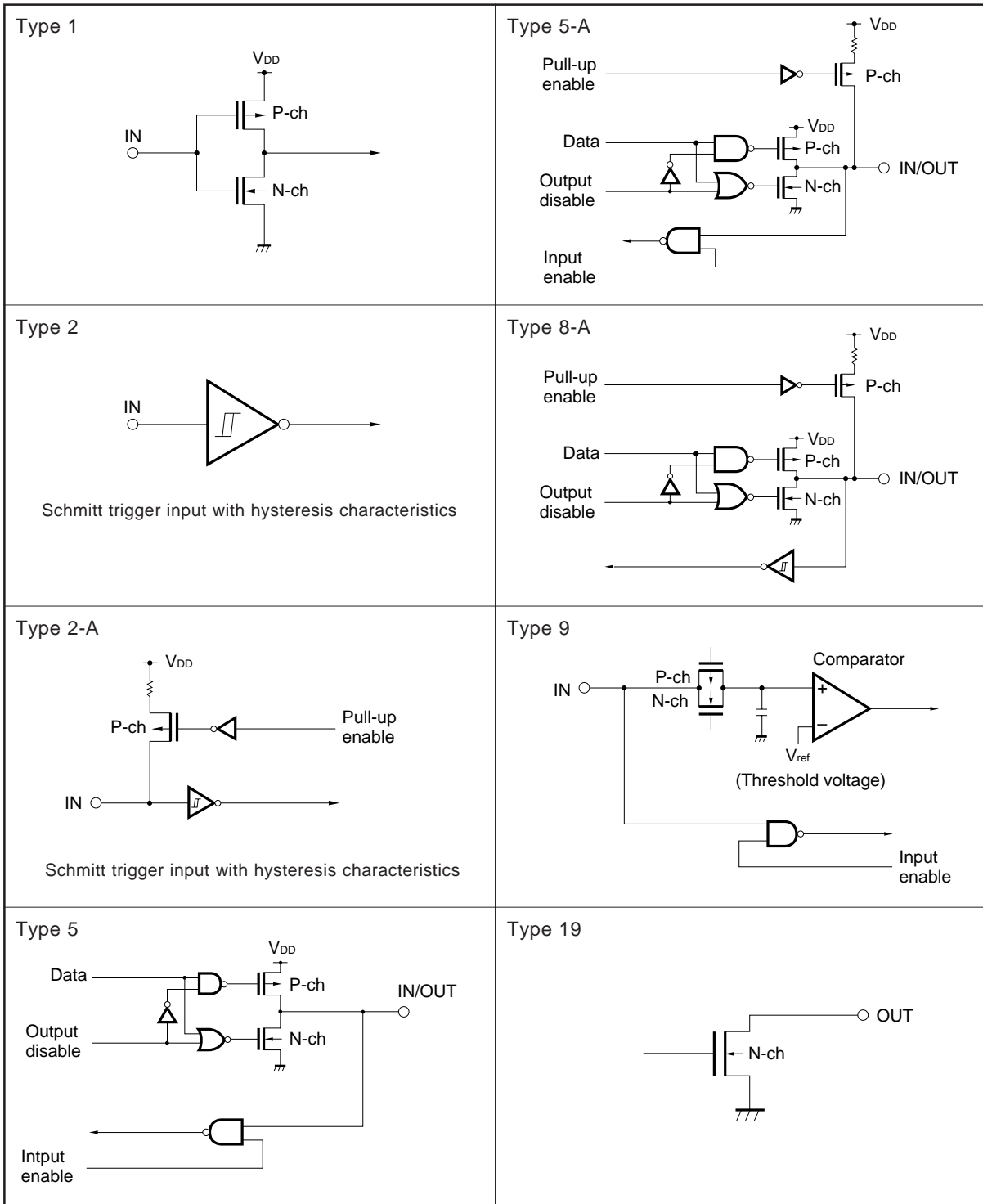
1.3 PIN I/O CIRCUITS AND PROCESSING OF UNUSED PINS

Table 1-1 shows the I/O circuit types of the respective pins, and recommended connections of the unused pins. Figure 1-1 shows the circuits of the respective pins.

Table 1-1. Pin I/O Circuit Type and Recommended Connections of Unused Pins

Pin	I/O circuit type	Recommended connections
P00/RTP0-P03/RTP3	5-A	Input : Independently connect to V <sub>DD</sub> or V <sub>SS</sub> through resistor Output : Leave unconnected
P04/PWM0		
P05/TCUD/PWM1		
P06/TIUD/TO40		
P07/TCLRUD		
P10-P17		
P20/NMI	2	Connect to V <sub>SS</sub>
P21/INTP0	2-A	
P22/INTP1		
P23/INTP2		
P24/INTP3/TI		
P25/INTP4		
P30/TxD0	5-A	Input : Independently connect to V <sub>DD</sub> or V <sub>SS</sub> through resistor Output : Leave unconnected
P31/RxD0	8-A	
P32/SO/SB0		
P33/SI/SB1		
P34/ $\overline{\text{SCK}}$	5-A	
P35/TxD1		
P36/RxD1		
P40/AD0-P47/AD7		
P50/A8-P57/A15	9	Connect to V <sub>SS</sub>
P70/ANI0-P77/ANI7		
P80/TO00-P85/TO05	5-A	Input : Independently connect to V <sub>DD</sub> or V <sub>SS</sub> through resistor Output : Leave unconnected
P90/ $\overline{\text{RD}}$		
P91/ $\overline{\text{WR}}$		
P92, P93		
ASTB	5	Connect to V <sub>SS</sub>
$\overline{\text{WDTO}}$	19	
MODE0, MODE1	1	
$\overline{\text{RESET}}$	2	-
AV <sub>REF</sub> , AV <sub>SS</sub>	-	
AV <sub>DD</sub>		
IC		

Figure 1-1. Pin I/O Circuits



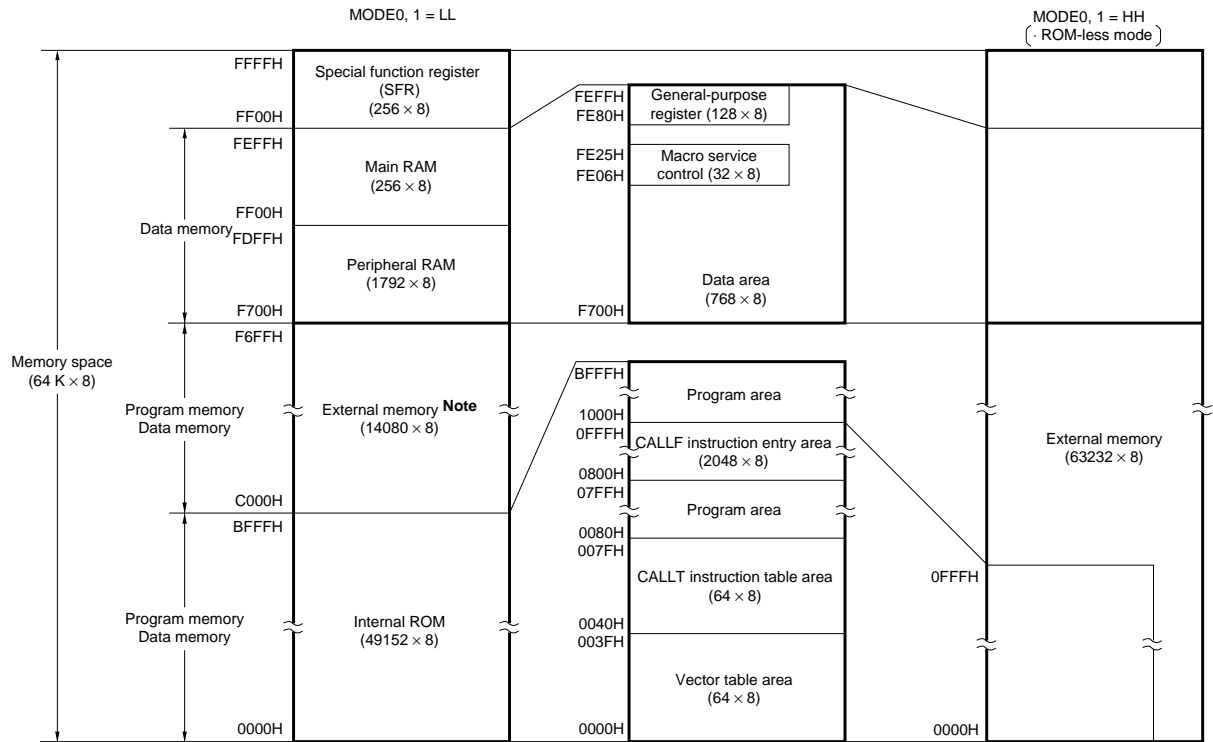
2. CPU ARCHITECTURE

2.1 MEMORY SPACE

The μPD78366A can access a memory space of 64K bytes. Figures 2-1 through 2-3 show the memory map.

★

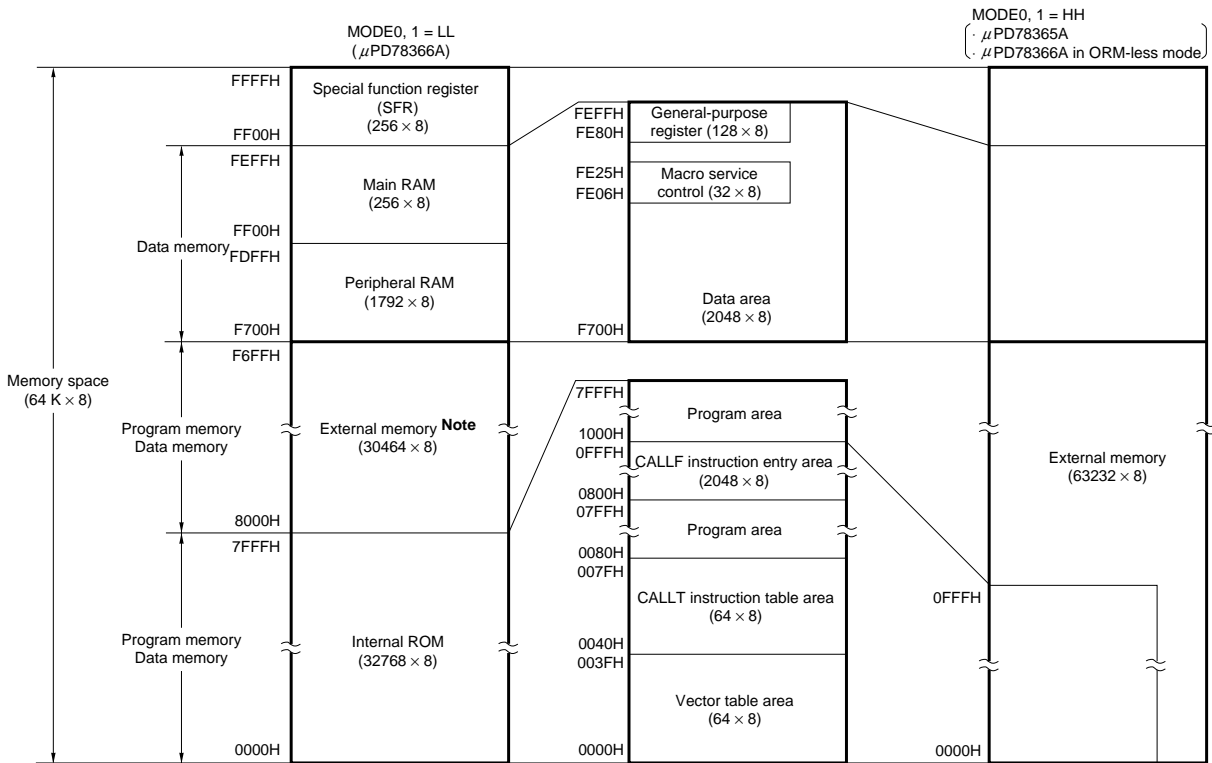
Figure 2-1. Memory Map (μPD78368A)



**Note** Accessed in external memory expansion mode.

**Caution** For word access (including stack operations) to the main RAM area (FE00H-FEFFFH), the address that specifies the operand must be an even value.

Figure 2-2. Memory Map (μPD78365A, 78366A)

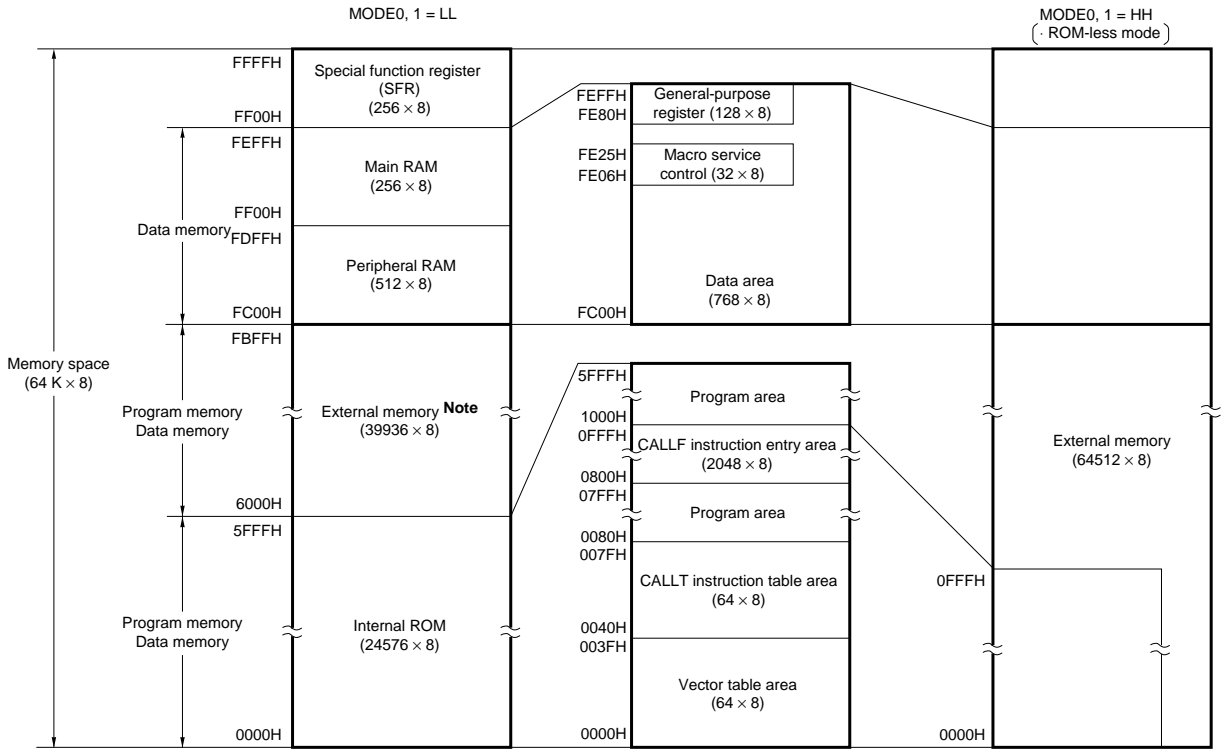


**Note** Accessed in external memory expansion mode.

**Caution** For word access (including stack operations) to the main RAM area (FE00H-FFFFH), the address that specifies the operand must be an even value.



Figure 2-3. Memory Map (μPD78363A)



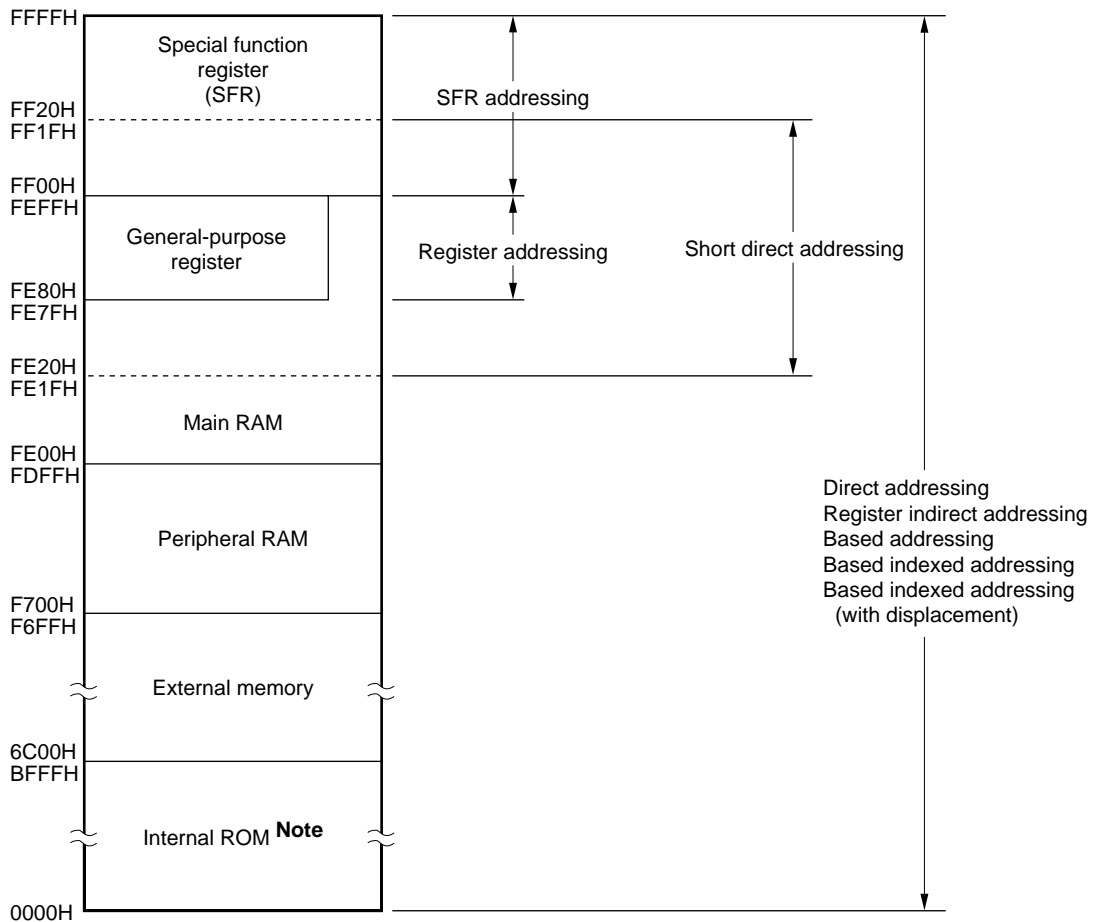
**Note** Accessed in external memory expansion mode.

**Caution** For word access (including stack operations) to the main RAM area (FE00H-FEFFFH), the address that specifies the operand must be an even value.

2.2 DATA MEMORY ADDRESSING

The μPD78366A is provided with many addressing modes that improve the operability of the memory and can be used with high-level languages. Especially, an area of addresses F700H-FFFFH (In the μPD78363A, FC00H-FFFFH) to which the data memory is mapped can be addressed in a mode peculiar to the functions provided in this area, including special function registers (SFR) and general-purpose registers.

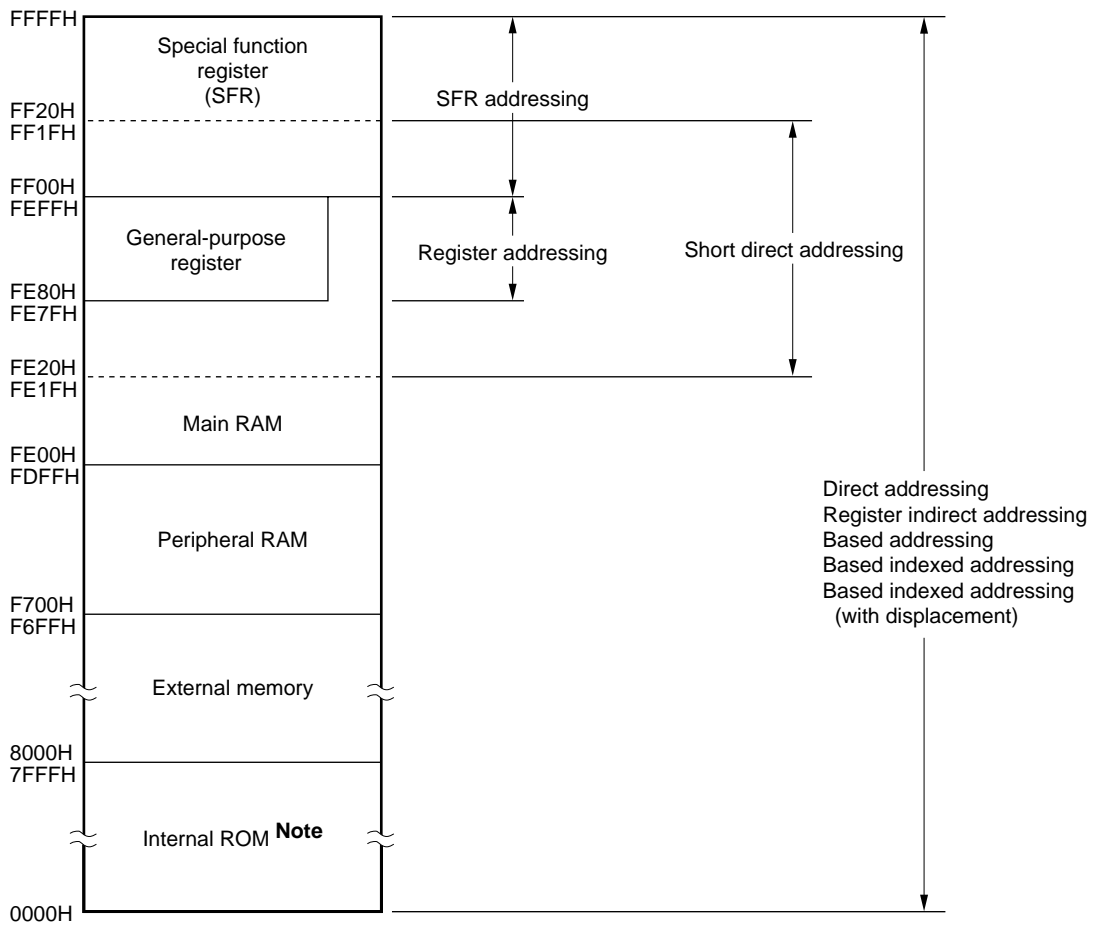
Figure 2-4. Data Memory Addressing (μPD78368A)



**Note** Is external memory in the ROMless mode.

**Caution** For word access (including stack operations) to the main RAM area (FE00H-FE7FH), the address that specifies the operand must be an even value.

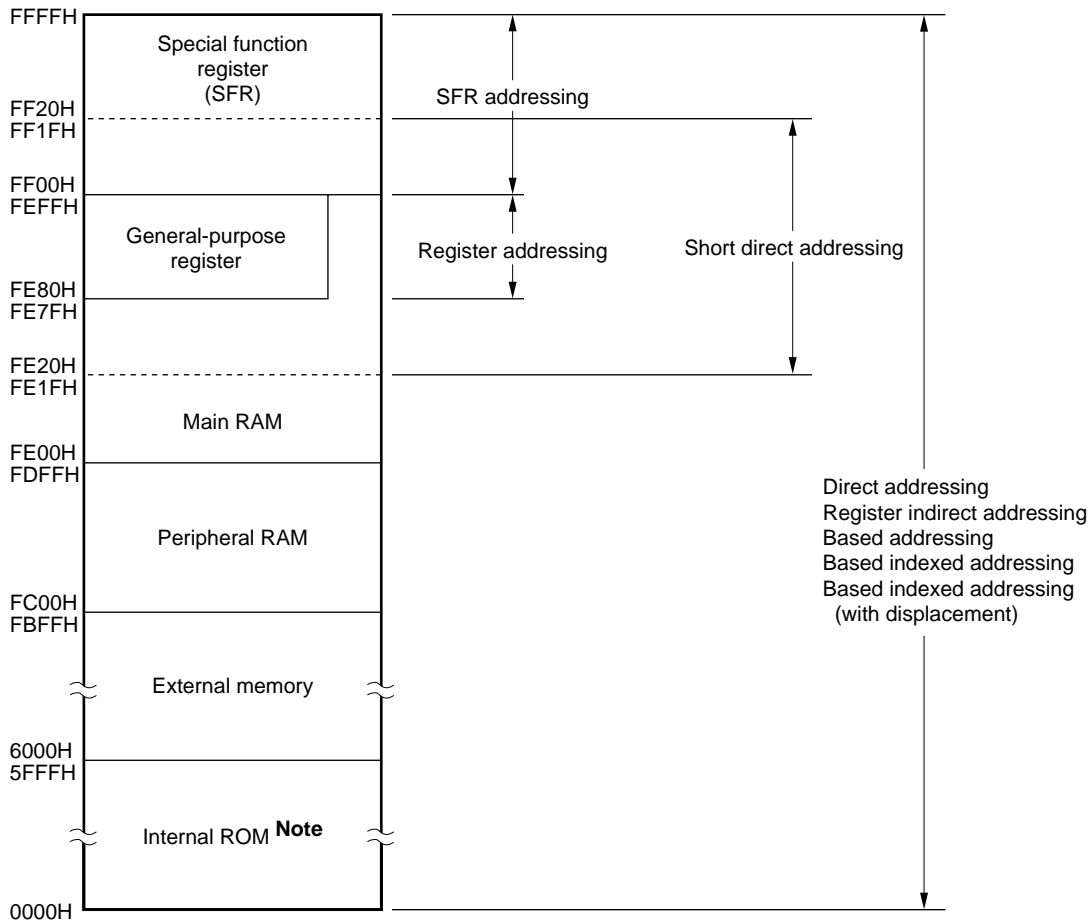
Figure 2-5. Data Memory Addressing (μPD78365A, 78366A)



**Note** Is external memory in the ROMless mode of the μPD78365A or μPD78366A.

**Caution** For word access (including stack operations) to the main RAM area (FE00H-FEFFFH), the address that specifies the operand must be an even value.

Figure 2-6. Data Memory Addressing (μPD78363A)



**Note** Is external memory in the ROMless mode.

**Caution** For word access (including stack operations) to the main RAM area (FE00H-FE7FH), the address that specifies the operand must be an even value.

### 2.3 PROCESSOR REGISTERS

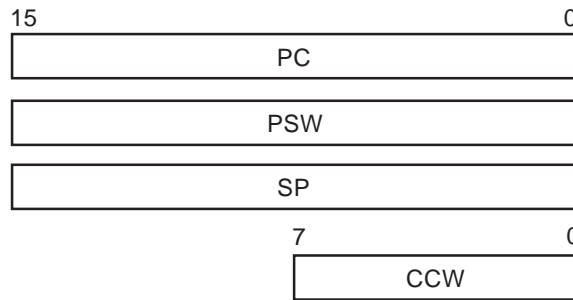
The μPD78366A is provided with the following three types of processor registers:

- Control registers
- General-purpose registers
- Special function registers (SFRs)

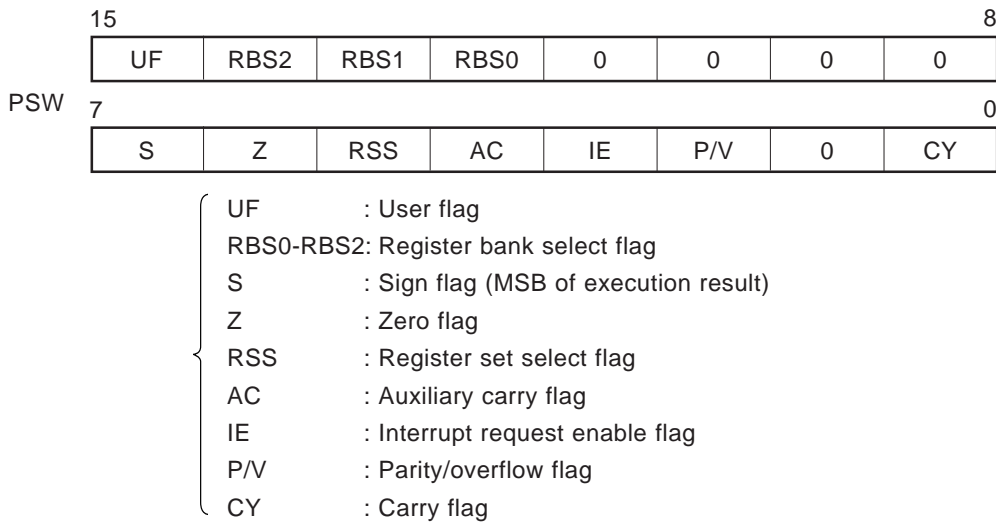
**2.3.1 Control Registers**

- (1) Program counter (PC)  
This is a 16-bit register that holds an address of the instruction to be executed next.
- (2) Program status word (PSW)  
This 16-bit register indicates the status of the CPU as a result of instruction execution.
- (3) Stack pointer (SP)  
This 16-bit register indicates the first address of the stack area (LIFO) of the memory.
- (4) CPU control word (CCW)  
This 8-bit register is used to control the CPU.

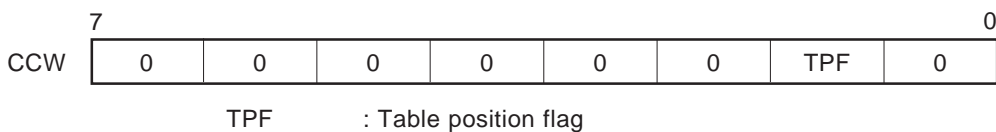
**Figure 2-7. Configuration of Control Registers**



**Figure 2-8. Configuration of PSW**



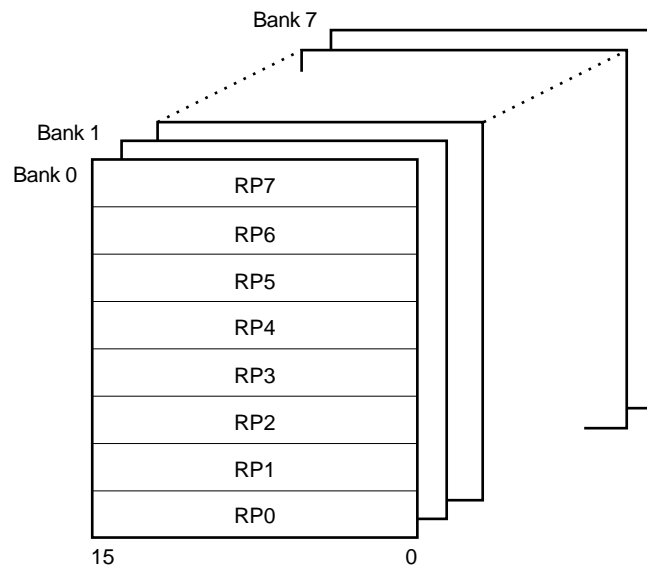
**Figure 2-9. Configuration of CCW**



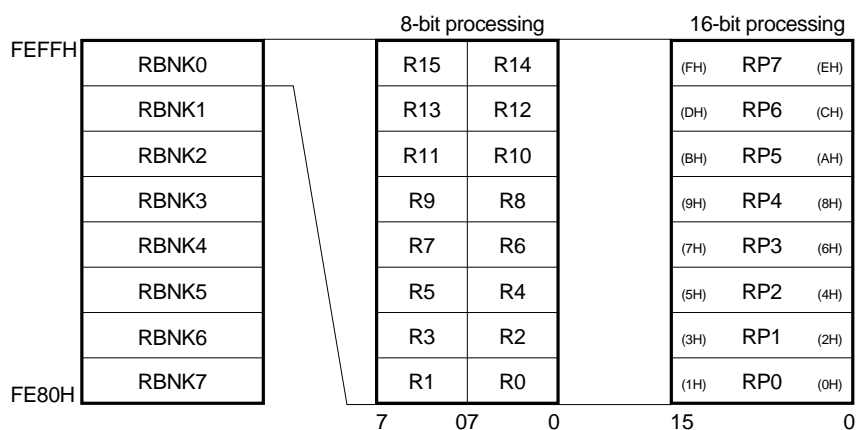
**2.3.2 General-Purpose Registers**

The μPD78366A is provided with eight banks of general-purpose registers with one bank consisting of 8 words × 16 bits. Figure 2-10 shows the configuration of the general-purpose register banks. The general-purpose registers are mapped to an area of addresses FE80H-FEFFFH. Each of these registers can be used as an 8-bit register. In addition, two registers can be used as one 16-bit register pair (refer to **Figure 2-11**). These general-purpose registers facilitate complicated multitask processing.

**Figure 2-10. Configuration of General-Purpose Register Banks**



**Figure 2-11. Processing Bits of General-Purpose Registers**



**2.3.3 Special Function Registers (SFR)**

Special function registers (SFRs) are registers assigned special functions such as mode registers and control registers for internal peripheral hardware, and are mapped to a 256-byte address space at FF00H through FFFFH.

Table 2-1 lists the SFRs. The meanings of the symbols in this table are as follows:

- Symbol ..... Indicates the mnemonic symbol for an SFR.  
This mnemonic can be coded in the operand field of an instruction.
- R/W ..... Indicates whether the SFR can be read or written.  
R/W : Read/write  
R : Read only  
W : Write only
- Bit units for manipulation ..... Indicates bit units in which the SFR can be manipulated. The SFRs that can be manipulated in 16-bit units can be coded as an sfrp operand. Specify an even address for these SFRs.  
The SFRs that can be manipulated in 1-bit units can be coded as the operand of bit manipulation instructions.
- On reset ..... Indicates the status of the register at  $\overline{\text{RESET}}$  input.

- Cautions**
1. Do not access the addresses in the range FF00H through FFFFH to which no special function register is allocated. If these addresses are accessed, malfunctioning may occur.
  2. Do not write data to the read-only registers. Otherwise, the internal circuit may not operate normally.
  3. When using read data as byte data, process undefined bit(s) first.
  4. TOUT and TXS are write-only registers. Do not read these registers.
  5. Bits 0, 1, and 4 of SBIC are write-only bits. When these bits are read, they are always "0".

Table 2-1. List of Special Function Registers (1/5)

Address	Special function register (SFR)	Symbol	R/W	Bit units for manipulation			On reset	
				1 bit	8 bits	16 bits		
FF00H	Port 0	P0	R/W	○	○	–	Undefined	
FF01H	Port 1	P1		○	○	–		
FF02H	Port 2	P2	R	○	○	–		
FF03H	Port 3	P3	R/W	○	○	–		
FF04H	Port 4	P4 <sup>Note</sup>		○	○	–		
FF05H	Port 5	P5 <sup>Note</sup>	○	○	–			
FF07H	Port 7	P7	R	○	○	–		
FF08H	Port 8	P8	R/W	○	○	–		
FF09H	Port 9	P9		○	○	–		
FF10H	Compare register 00	CM00		–	–	○		
FF11H				–	–	○		
FF12H	Compare register 01	CM01		–	–	○		
FF13H				–	–	○		
FF14H	Compare register 02	CM02		–	–	○		
FF15H				–	–	○		
FF16H	Compare register 03	CM03		–	–	○		
FF17H				–	–	○		
FF18H	Buffer register CM00	BFCM00		–	–	○		
FF19H				–	–	○		
FF1AH	Buffer register CM01	BFCM01		–	–	○		
FF1BH				–	–	○		
FF1CH	Buffer register CM02	BFCM02		–	–	○		
FF1DH				–	–	○		
FF1EH	Timer register 0	TM0		R	–	–	○	0000H
FF1FH			–	–	○	0000H		
FF20H	Port 0 mode register	PM0	R/W	○	○	–	FFH	
FF21H	Port 1 mode register	PM1		○	○	–	FFH	
FF23H	Port 3 mode register	PM3		○	○	–	×111 1111B	
FF25H	Port 5 mode register	PM5 <sup>Note</sup>		○	○	–	FFH	
FF28H	Port 8 mode register	PM8		○	○	–	××11 1111B	
FF29H	Port 9 mode register	PM9		○	○	–	×××× 1111B	
FF2CH	Reload register	DTIME	R/W	–	–	○	Undefined	
FF2DH				–	–	○	Undefined	
FF2EH	Timer unit mode register 0	TUM0		○	○	–	00H	
FF2FH	Timer unit mode register 1	TUM1		○	○	–		
FF30H	Compare register 10	CM10		–	–	○	Undefined	
FF31H				–	–	○		
FF32H	Timer register 1	TM1		R	–	–	○	0000H
FF33H				–	–	○	0000H	

**Note** Not provided for the μPD78365A.



Table 2-1. List of Special Function Registers (2/5)

Address	Special function register (SFR)	Symbol	R/W	Bit units for manipulation			On reset
				1 bit	8 bits	16 bits	
FF34H	Capture/compare register 20	CC20	R/W	-	-	○	Undefined
FF35H							
FF36H	Capture register 20	CT20	R	-	-	○	0000H
FF37H							
FF38H	Timer register 2	TM2	R	-	-	○	0000H
FF39H							
FF3AH	Buffer register CM03	BFCM03	R/W	-	-	○	Underfined
FF3BH							
FF3CH	External interrupt mode register 0	INTM0		○	○	-	00H
FF3DH	External interrupt mode register 1	INTM1		○	○	-	
FF40H	Port 0 mode control register	PMC0		○	○	-	×000 0000B
FF43H	Port 3 mode control register	PMC3		○	○	-	
FF44H	Pull-up resistor option register L	PUOL	R/W	○	○	-	00H
FF45H	Pull-up resistor option register H	PUOH		○	○	-	
FF48H	Port 8 mode control register	PMC8		○	○	-	××00 0000B
FF4EH	Sampling control register 0	SMPC0		○	○	-	00H
FF4FH	Sampling control register 1	SMPC1		○	○	-	
FF50H	Capture/compare register 30	CC30	R	-	-	○	Undefined
FF51H							
FF52H	Capture register 30	CT30	R	-	-	○	Undefined
FF53H							
FF54H	Capture register 31	CT31	R	-	-	○	0000H
FF55H							
FF56H	Timer register 3	TM3	R	-	-	○	0000H
FF57H							
FF58H	Compare register 40	CM40	R/W	-	-	○	Undefined
FF59H							
FF5AH	Compare register 41	CM41	R/W	-	-	○	Undefined
FF5BH							
FF5CH	Timer register 4	TM4	R	-	-	○	0000H
FF5DH							
FF5EH	Timer control register 4	TMC4	R/W	-	○	-	00H
FF5FH	Timer out register	TOUT	W	-	○	-	××01 0101B
FF60H	Real-time output port register	RTP	R/W	○	○	-	Undefined
FF61H	Real-time output port mode register	RTPM		○	○	-	
FF62H	Port read control register	PRDC		○	○	-	00H
FF68H	A/D converter mode register	ADM		○	○	-	

Table 2-1. List of Special Function Registers (3/5)

Address	Special function register (SFR)	Symbol	R/W	Bit units for manipulation			On reset	
				1 bit	8 bits	16 bits		
FF70H	Slave buffer register 0	SBUF0	R/W	○	○	–	Undefined	
FF71H	Slave buffer register 1	SBUF1		○	○	–		
FF72H	Slave buffer register 2	SBUF2		○	○	–		
FF73H	Slave buffer register 3	SBUF3		○	○	–		
FF74H	Slave buffer register 4	SBUF4		○	○	–		
FF75H	Slave buffer register 5	SBUF5		○	○	–		
FF76H	Master buffer register 0	MBUF0		○	○	–		
FF77H	Master buffer register 1	MBUF1		○	○	–		
FF78H	Master buffer register 2	MBUF2		○	○	–		
FF79H	Master buffer register 3	MBUF3		○	○	–		
FF7AH	Master buffer register 4	MBUF4		○	○	–		
FF7BH	Master buffer register 5	MBUF5		○	○	–		
FF7CH	Timer control register 0	TMC0		○	○	–		00H
FF7DH	Timer control register 1	TMC1		○	○	–		
FF7EH	Timer control register 2	TMC2		○	○	–		
FF7FH	Timer control register 3	TMC3		○	○	–		
FF80H	Clocked serial interface mode register	CSIM	○	○	–			
FF82H	Serial bus interface control register	SBIC	R/W <sup>Note</sup>	○	○	–	Undefined	
FF84H	Baud rate generator control register	BRGC	R/W	○	○	–		
FF85H	Baud rate generator compare register	BRG		–	○	–		
FF86H	Serial I/O shift register	SIO		○	○	–		
FF88H	Asynchronous serial interface mode register	ASIM	R	○	○	–	80H	
FF8AH	Asynchronous serial interface status register	ASIS		○	○	–	00H	
FF8CH	Serial receive buffer: UART	RXB	W	–	○	–	Undefined	
FF8EH	Serial transfer shift register: UART	TXS		–	○	–		
FFA0H	PWM control register 0	PWMC0	R/W	○	○	–	00H	
FFA1H	PWM control register 1	PWMC1		○	○	–		
FFA2H	PWM register 0L	PWM0L		○	○	–	Undefined	
FFA2H	PWM register 0	PWM0		–	–	○		
FFA3H				–	–	○		

**Note** Bits 7 and 5 : read/write  
 Bits 6, 3, and 2 : read-only  
 Bits 4, 1, and 0 : write-only

Table 2-1. List of Special Function Registers (4/5)

Address	Special function register (SFR)	Symbol	R/W	Bit units for manipulation			On reset
				1 bit	8 bits	16 bits	
FFA4H	PWM register 1L	PWM1L	R/W	○	○	–	Undefined
FFA4H	PWM register 1	PWM1		–	–	○	
FFA5H							
FFA8H	In-service priority register	ISPR	R	○	○	–	00H
FFAAH	Interrupt mode control register	IMC	R/W	○	○	–	80H
FFACH	Interrupt mask register 0L	MK0L		○	○	–	FFH
FFACH	Interrupt mask register 0	MK0		–	–	○	FFFFH
FFADH						○	○
FFADH	Interrupt mask register 0H	MK0H	R	–	–	○	Undefined
FFB0H	A/D conversion result register 0	ADCR0		–	–	○	
FFB1H						–	
FFB1H	A/D conversion result register 0H	ADCR0H		–	○	–	
FFB2H	A/D conversion result register 1	ADCR1		–	–	○	
FFB3H						–	
FFB3H	A/D conversion result register 1H	ADCR1H		–	○	–	
FFB4H	A/D conversion result register 2	ADCR2		–	–	○	
FFB5H						–	
FFB5H	A/D conversion result register 2H	ADCR2H		–	○	–	
FFB6H	A/D conversion result register 3	ADCR3		–	–	○	
FFB7H						–	
FFB7H	A/D conversion result register 3H	ADCR3H		–	○	–	
FFB8H	A/D conversion result register 4	ADCR4		–	–	○	
FFB9H						–	
FFB9H	A/D conversion result register 4H	ADCR4H		–	○	–	
FFBAH	A/D conversion result register 5	ADCR5		–	–	○	
FFBBH						–	
FFBBH	A/D conversion result register 5H	ADCR5H		–	○	–	
FFBCH	A/D conversion result register 6	ADCR6		–	–	○	
FFBDH						–	
FFBDH	A/D conversion result register 6H	ADCR6H		–	○	–	
FFBEH	A/D conversion result register 7	ADCR7		–	–	○	
FFBFH						–	
FFBFH	A/D conversion result register 7H	ADCR7H	–	○	–		
FFC0H	Standby control register	STBC <sup>Note</sup>	R/W	–	○	–	0000 × 000B
FFC1H	CPU control word	CCW		○	○	–	00H
FFC2H	Watchdog timer mode register	WDM <sup>Note</sup>		–	○	–	

**Note** Can be written when a special instruction is executed.

Table 2-1. List of Special Function Registers (5/5)

Address	Special function register (SFR)	Symbol	R/W	Bit units for manipulation			On reset
				1 bit	8 bits	16 bits	
FFC4H	Memory expansion mode register	MM	R/W	○	○	–	Note
FFC6H	Programmable wait control register	PWC		–	–	○	C0AAH
FFC7H							
FFD0H   FFDFH	External SFR area	–		○	○	–	Undefined
FFE0H	Interrupt control register (INTOV3)	OVIC3		○	○	–	43H
FFE1H	Interrupt control register (INTP0/INTCC30)	PIC0		○	○	–	
FFE2H	Interrupt control register (INTP1)	PIC1		○	○	–	
FFE3H	Interrupt control register (INTP2)	PIC2		○	○	–	
FFE4H	Interrupt control register (INTP3/INTCC20)	PIC3		○	○	–	
FFE5H	Interrupt control register (INTP4)	PIC4		○	○	–	
FFE6H	Interrupt control register (INTTM0)	TMIC0		○	○	–	
FFE7H	Interrupt control register (INTCM03)	CMIC03		○	○	–	
FFE8H	Interrupt control register (INTCM10)	CMIC10		○	○	–	
FFE9H	Interrupt control register (INTCM40)	CMIC40		○	○	–	
FFEAH	Interrupt control register (INTCM41)	CMIC41		○	○	–	
FFEBH	Interrupt control register (INTSER)	SERIC		○	○	–	
FFECH	Interrupt control register (INTSR)	SRIC		○	○	–	
FFEDH	Interrupt control register (INTST)	STIC		○	○	–	
FFEEH	Interrupt control register (INTCSI)	CSIIC		○	○	–	
FFEFH	Interrupt control register (INTAD)	ADIC		○	○	–	

**Note** The value of the MW register at reset time differs depending on the product.

μPD78363A : 60H

μPD78365A, 78366A : 20H

★ μPD78368A : 00H

### 3. FUNCTIONAL BLOCKS

#### 3.1 EXECUTION UNIT (EXU)

EXU controls address computation, arithmetic and logical operations, and data transfer through microprogram. EXU has an internal main RAM. This RAM can be accessed by instructions faster than the peripheral RAM.

#### 3.2 BUS CONTROL UNIT (BCU)

BCU starts necessary bus cycles according to the physical address obtained by the execution unit (EXU). If EXU does not request start of the bus cycle, an address is generated to prefetch an instruction. The prefetched op code is stored in an instruction queue.

#### 3.3 ROM/RAM

The internal ROM and RAM capacities differ depending on the product.

The  $\mu$ PD78363A has a 24-KB ROM and a 512-B peripheral RAM. The  $\mu$ PD78366A has a 32-KB ROM and a 1792-B peripheral RAM. The  $\mu$ PD78368A has a 48-KB ROM and a 1792-B peripheral RAM. The  $\mu$ PD78365A does not have a ROM and only has a 1792-B peripheral RAM.

Access to the ROM can be disabled by using the MODE0 and MODE1 pins, in which case an external memory of 64 KB can be accessed.

3.4 PORT FUNCTIONS

The μPD78366A is provided with the ports shown in Figure 3-1 for various control operations.

The functions of each port are listed in Table 3-1. These ports function not only as digital ports but also as input/output lines of the internal hardware.

Figure 3-1. Port Configuration

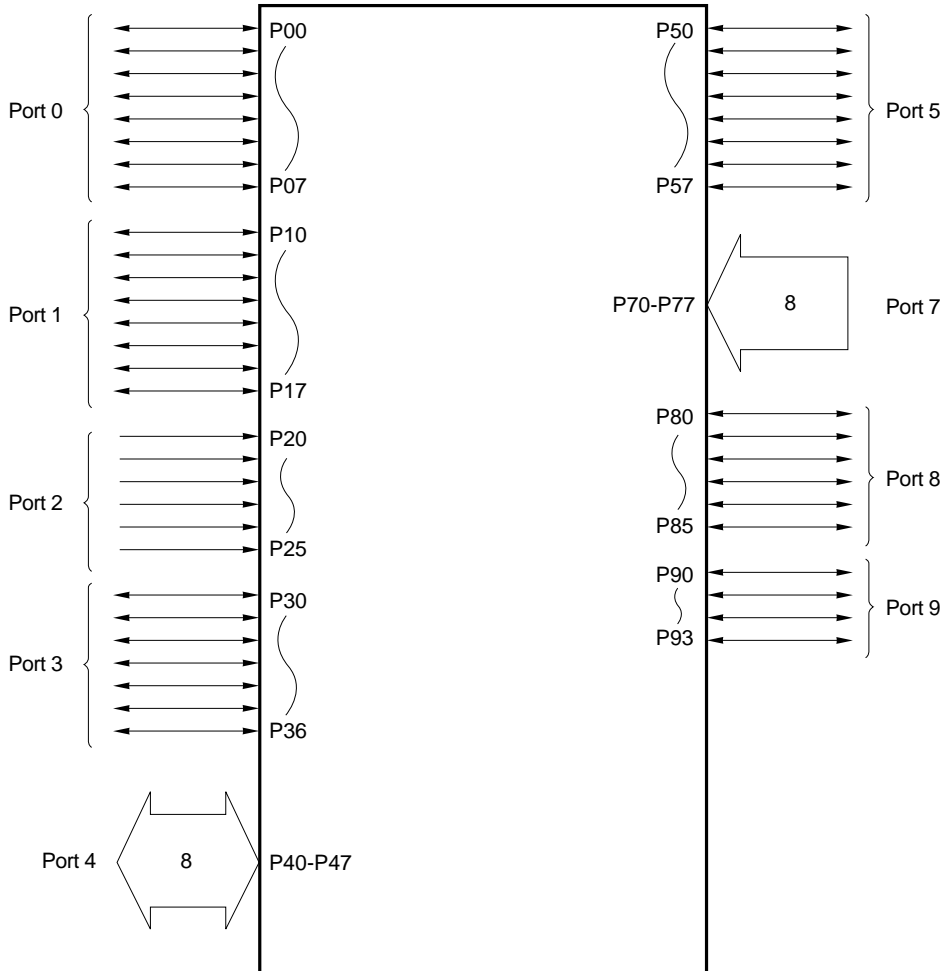


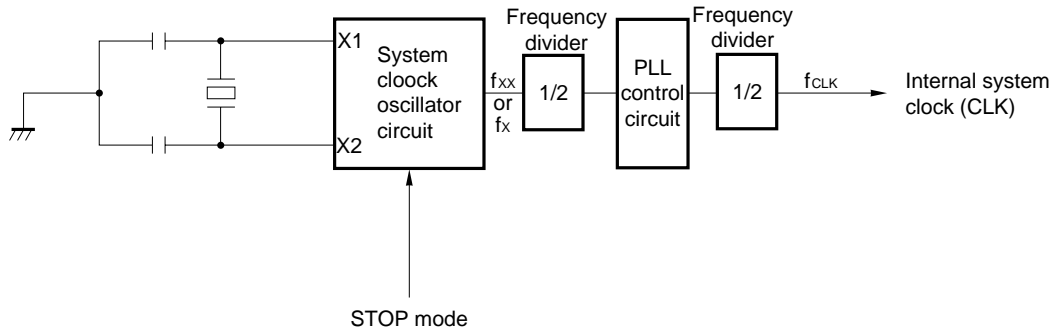
Table 3-1. Functions of Each Port

Port	Port function	Multiplexed function
Port 0	8-bit I/O port. Can be set in input or output mode in 1-bit units.	In control mode, serves as real-time output port (RTP), or input operation control signal of real-time pulse unit (RPU) and output PWM signal.
Port 1	8-bit I/O port. Can be set in input or output mode in 1-bit units.	—
Port 2	6-bit input port.	Inputs external interrupt and count pulse of real-time pulse unit (RPU) (fixed to the control mode).
Port 3	7-bit I/O port. Can be set in input or output in 1-bit units.	In control mode, inputs/outputs signals of serial interfaces (UART, CSI).
Port 4	8-bit I/O port. Can be set in input or output mode in 8-bit units.	Address data bus (AD0-AD7) when memory is externally expanded.
Port 5	8-bit I/O port. Can be set in input or output mode in 1-bit units.	Address bus (A8-A15) when memory is externally expanded.
Port 7	8-bit input port.	Input analog signals to A/D converter (fixed to the control mode).
Port 8	6-bit I/O port. Can be set in input or output mode in 1-bit units.	In control mode, outputs timer of real-time pulse unit (RPU).
Port 9	4-bit I/O port. Can be set in input or output mode in 1-bit units.	Outputs control signal when memory is externally expanded.

3.5 CLOCK GENERATOR CIRCUIT

The clock generator circuit generates and controls the internal system clock (CLK) that is supplied to the CPU.

Figure 3-2. Block Diagram of Clock Generator Circuit



- Remarks**
1.  $f_{xx}$  : crystal oscillation frequency
  2.  $f_x$  : external clock frequency
  3.  $f_{CLK}$ : internal system clock frequency

By connecting an 8-MHz crystal resonator across the X1 and X2 pins, an internal system clock of up to 16 MHz ( $f_{CLK}$ ) can be generated.

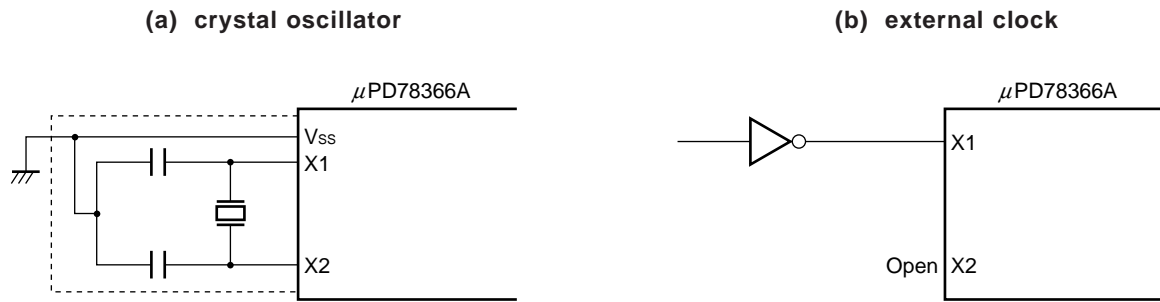
The system clock oscillation circuit oscillates by using the crystal resonator connected across the X1 and X2 pins. It stops oscillation in standby mode.

An external clock can also be input. To do so, input the clock signal to the X1 pin and leave the X2 pin open.

**Caution** Do not set STOP mode when the external clock is used.



Figure 3-3. External Circuit of System Clock Oscillator Circuit



- Cautions**
1. Wire the portion enclosed by dotted line in Figure 3-3 as follows to avoid adverse influences due to wiring capacity when using the system clock oscillation circuit.
    - Keep the wiring length as short as possible.
    - Do not cross the wiring with the other signal line. Make sure that the wiring is not close to lines through which a high alternating current flows.
    - Always keep the ground point of the capacitor of the oscillation circuit at the same potential as  $V_{ss}$ . Do not ground the circuit to a ground pattern through which a high current flows.
    - Do not extract signals from the oscillator circuit.
  2. To input an external clock, do not connect a load such as wiring capacitance to the X2 pin.

### 3.6 REAL-TIME PULSE UNIT (RPU)

The real-time pulse unit (RPU) can measure pulse intervals and frequencies, and output programmable pulses (six channels of PWM control signals).

The RPU consists of five 16-bit timers (timers 0 through 4), of which one is provided with a 10-bit dead time timer, which is ideal for inverter control. In addition, a function to turn off the output by the software or an external interrupt is also provided.

Each timer has the following features:

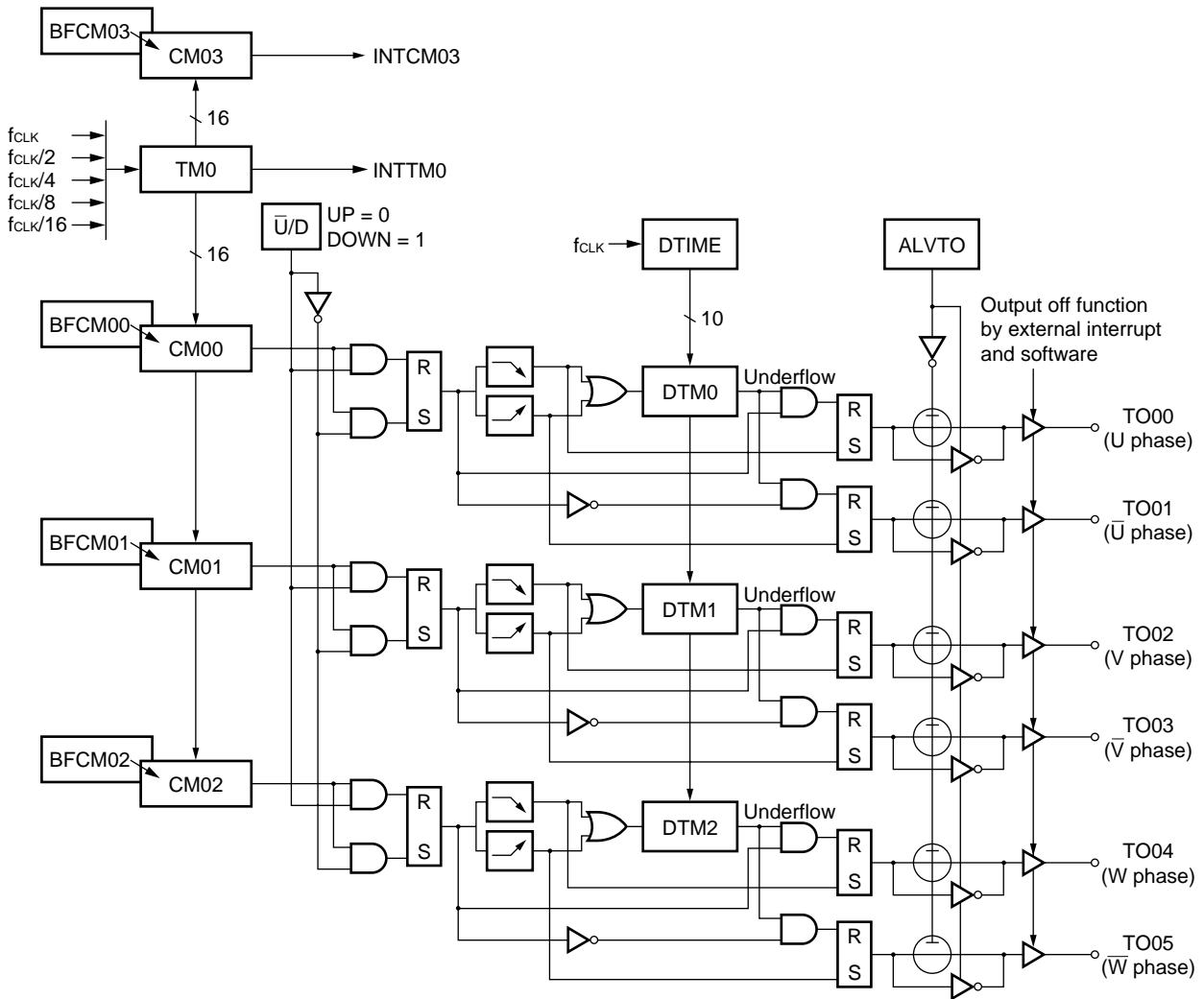
- Timer 0 : Controls the PWM period of the TO00 through TO05 pins. In addition, operates as a general-purpose interval timer. Timer 0 has the following five operation modes:
  - General-purpose interval timer mode
  - PWM mode 0 (symmetrical triangular wave)
  - PWM mode 0 (asymmetrical triangular wave)
  - PWM mode 0 (saw-tooth wave)
  - PWM mode 1
- Timer 1 : Operates as a general-purpose interval timer.
- Timers 2, 3 : Has a programmable input sampling circuit that rejects the noise of an input signal, and a capture function.
- Timer 4 : Operates as a general-purpose timer or an up-down counter. When operating as a general-purpose timer, controls the PWM cycle of the TO40 output pin. Timer 4 has the following two operation modes:
  - General-purpose timer mode
  - Up/down counter mode (UDC mode)

The RPU consists of the hardware shown in Table 3-2. Figures 3-4 through 3-12 show the block diagrams of the respective timers.

**Table 3-2. Configuration of Real-Time Pulse Unit (RPU)**

	Timer register	Register	Compare register coincidence interrupt	Capture trigger	Timer output	Timer clear
Timer 0	16-bit timer (TM0)	16-bit compare register (CM00)	–	–	6	INTCM03
		16-bit compare register (CM01)	–			
		16-bit compare register (CM02)	–			
		16-bit compare register (CM03)	INTCM03			
Timer 1	16-bit timer (TM1)	16-bit compare register (CM10)	INTCM10	–	–	INTCM10
Timer 2	16-bit timer (TM2)	16-bit capture/compare register (CC20)	INTCC20	INTP3	–	INTCC20
		16-bit capture register (CT20)	–			
Timer 3	16-bit timer (TM3)	16-bit capture/compare register (CC30)	INTCC30	INTP0 INTP1 INTP4	–	INTCC30
		16-bit capture register (CT30)	–			
		16-bit capture register (CT31)	–			
Timer 4	16-bit timer (TM4)	16-bit compare register (CM40)	INTCM40	–	1	TCLRUD INTCM40
		16-bit compare register (CM41)	INTCM41			

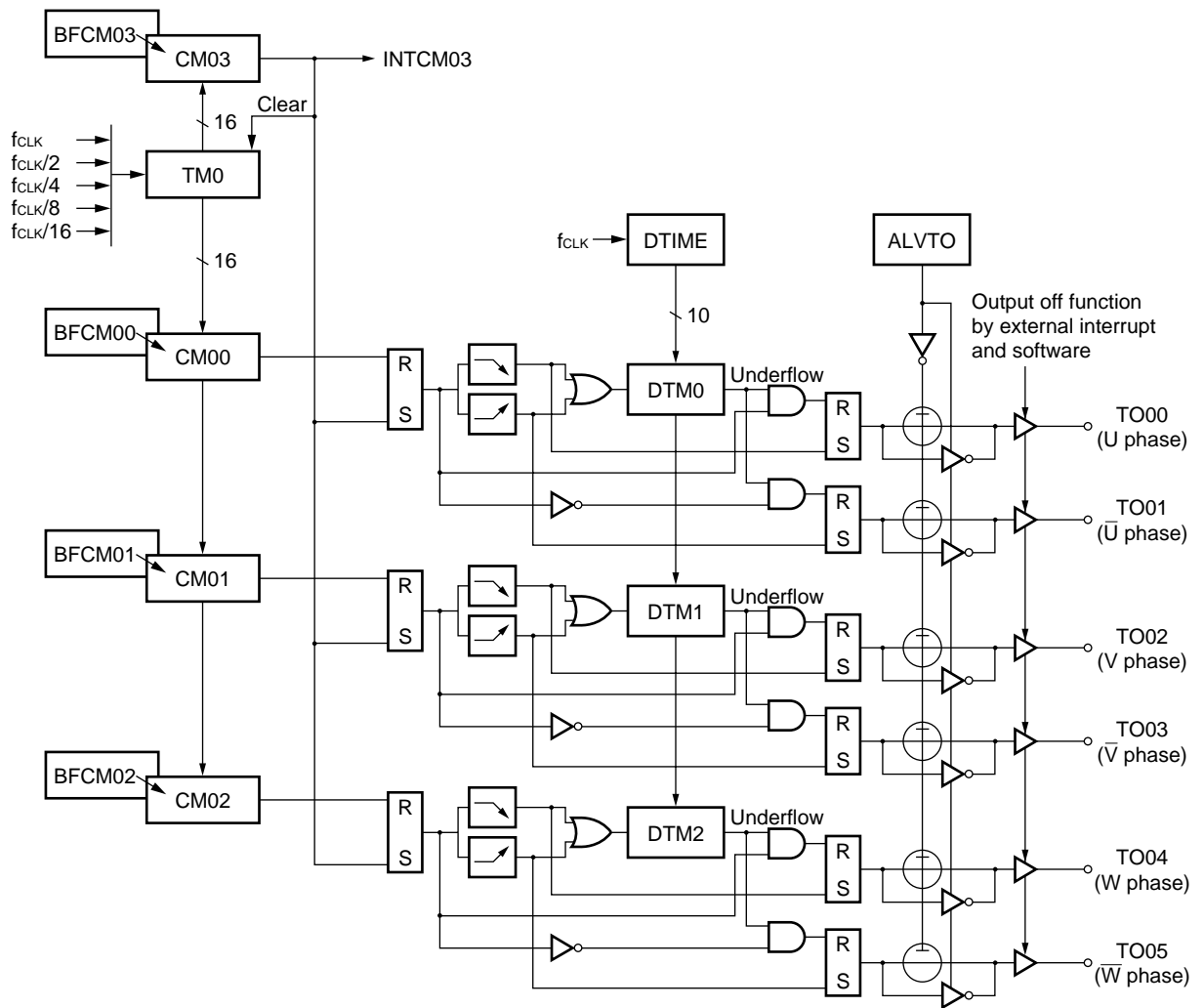
Figure 3-4. Block Diagram of Timer 0 (PWM mode 0 ... symmetrical triangular wave, asymmetrical triangular wave)



TM0	: Timer register	ALVTO:	Bit 2 of TUM0 register
CM00-CM03	: Compare registers	U/D	: Bit 3 of TMC0 register
BFCM00-BFCM03	: Buffer registers		
DTIME	: Reload register		
DTM0-DTM2	: Dead time timers		

**Remark** fCLK: internal system clock

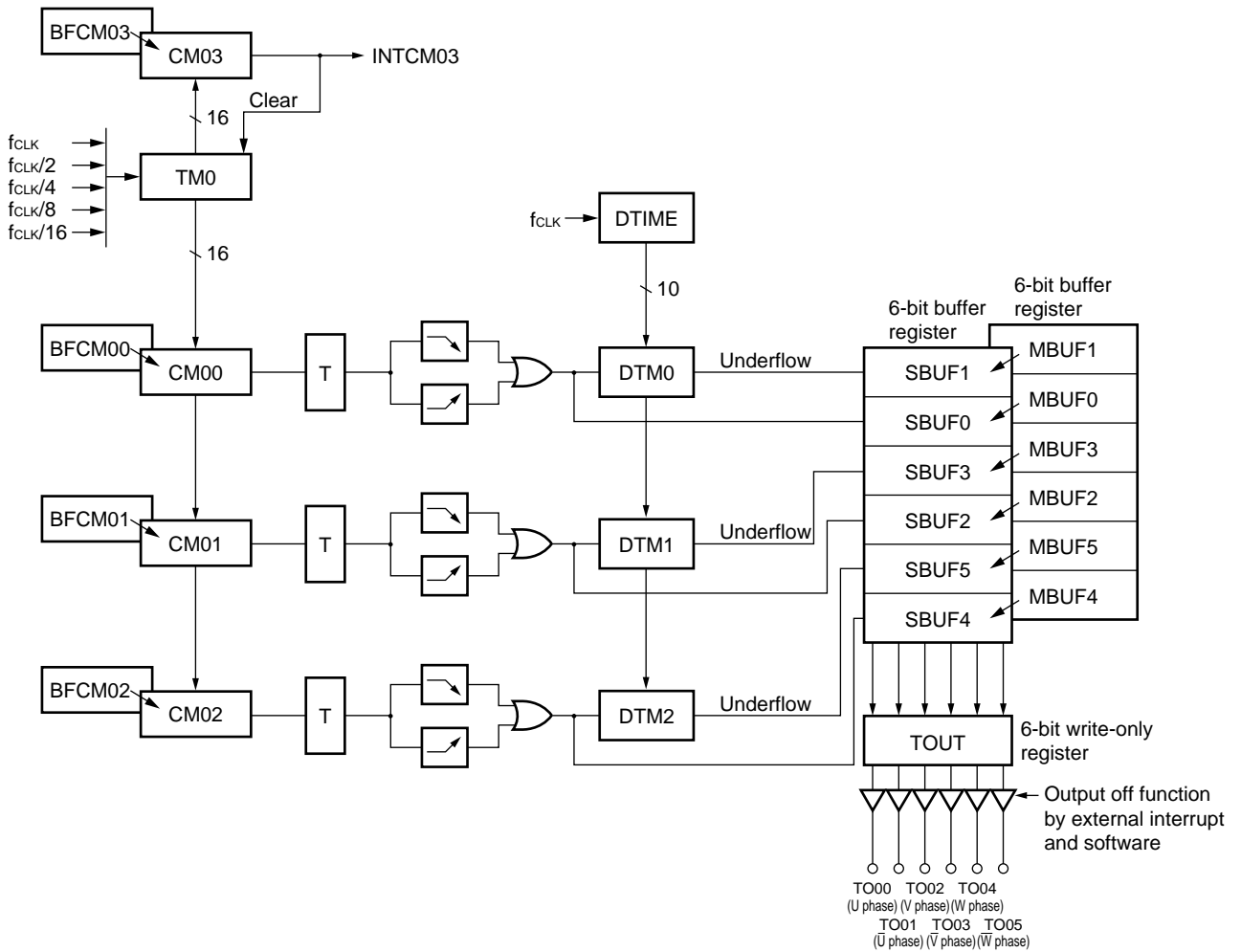
Figure 3-5. Block Diagram of Timer 0 (PWM mode 0 ... saw-tooth wave)



- TM0 : Timer register
- CM00-CM03 : Compare registers
- BFCM00-BFCM03: Buffer registers
- DTIME : Reload register
- DTM0-DTM2 : Dead time timers
- ALVTO : Bit 2 of TUM0 register

**Remark** f<sub>CLK</sub>: internal system clock

Figure 3-6. Block Diagram of Timer 0 (PWM mode 1)



- |               |                     |             |                           |
|---------------|---------------------|-------------|---------------------------|
| TM0           | : Timer register    | MBUF0-MBUF5 | : Master buffer registers |
| CM00-CM03     | : Compare registers | SBUF0-SBUF5 | : Slave buffer registers  |
| BFCM00-BFCM03 | : Buffer registers  | TOUT        | : Timer out register      |
| DTIME         | : Reload register   |             |                           |
| DTM0-DTM2     | : Dead time timers  |             |                           |

**Remark** f<sub>CLK</sub>: internal system clock

Figure 3-7. Block Diagram of Timer 0 (general-purpose interval timer mode)

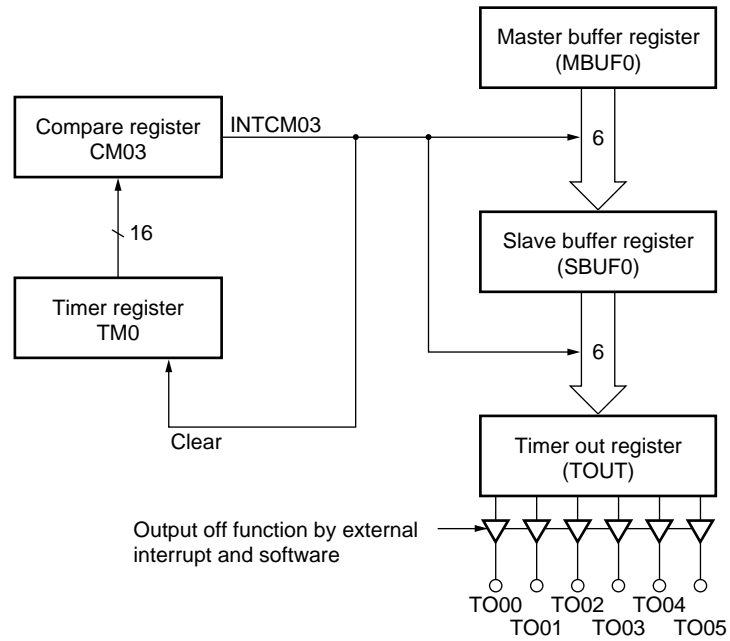
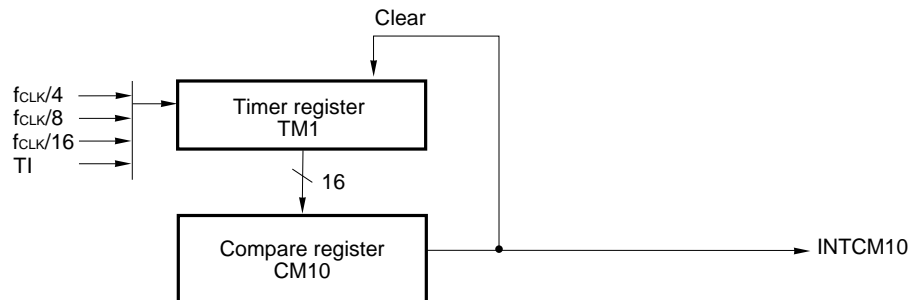
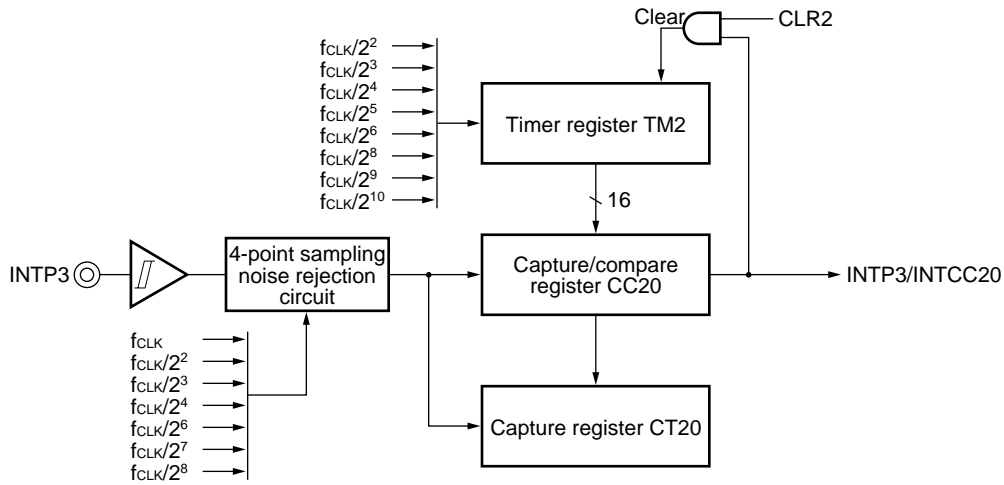


Figure 3-8. Block Diagram of Timer 1



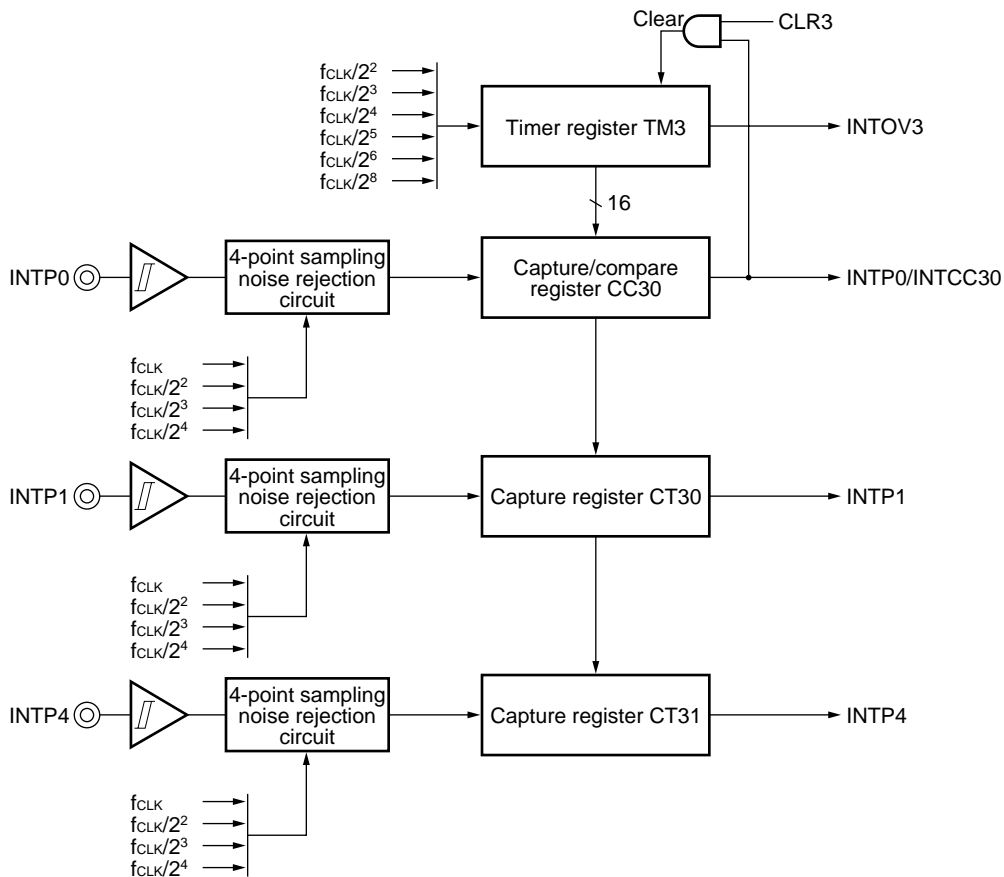
Remark f<sub>CLK</sub>: internal system clock

Figure 3-9. Block Diagram of Timer 2



Remark f<sub>CLK</sub>: internal system clock

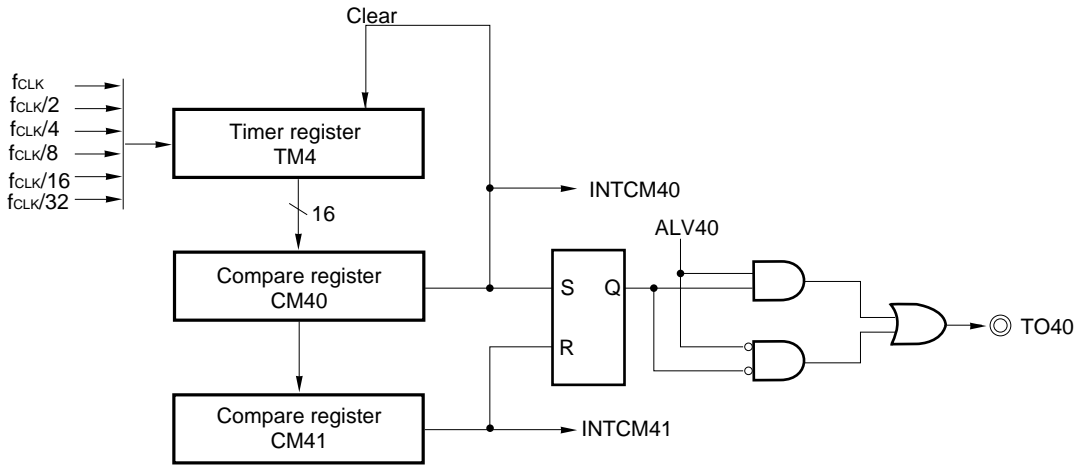
Figure 3-10. Block Diagram of Timer 3



Remark f<sub>CLK</sub>: internal system clock

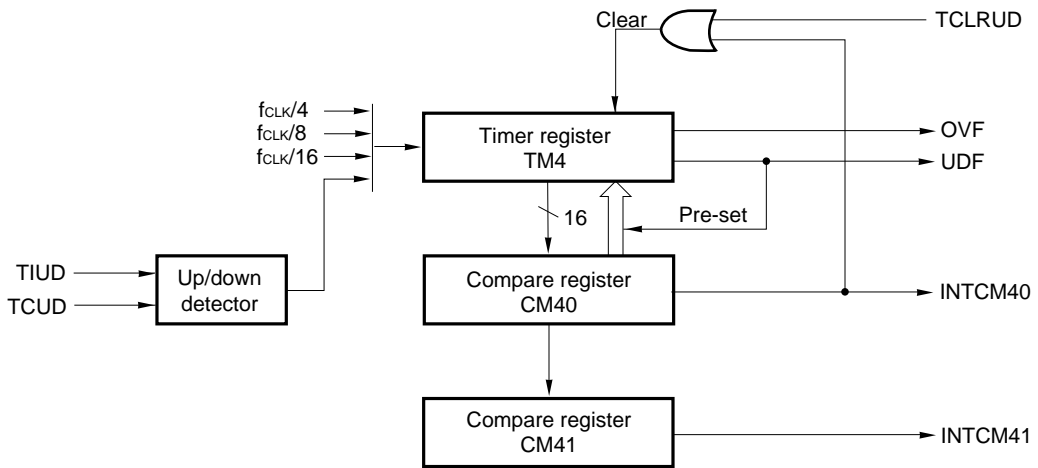


Figure 3-11. Block Diagram of Timer 4 (General-Purpose Timer Mode)



Remark f<sub>CLK</sub>: internal system clock

Figure 3-12. Block Diagram of Timer 4 (UDC Mode)



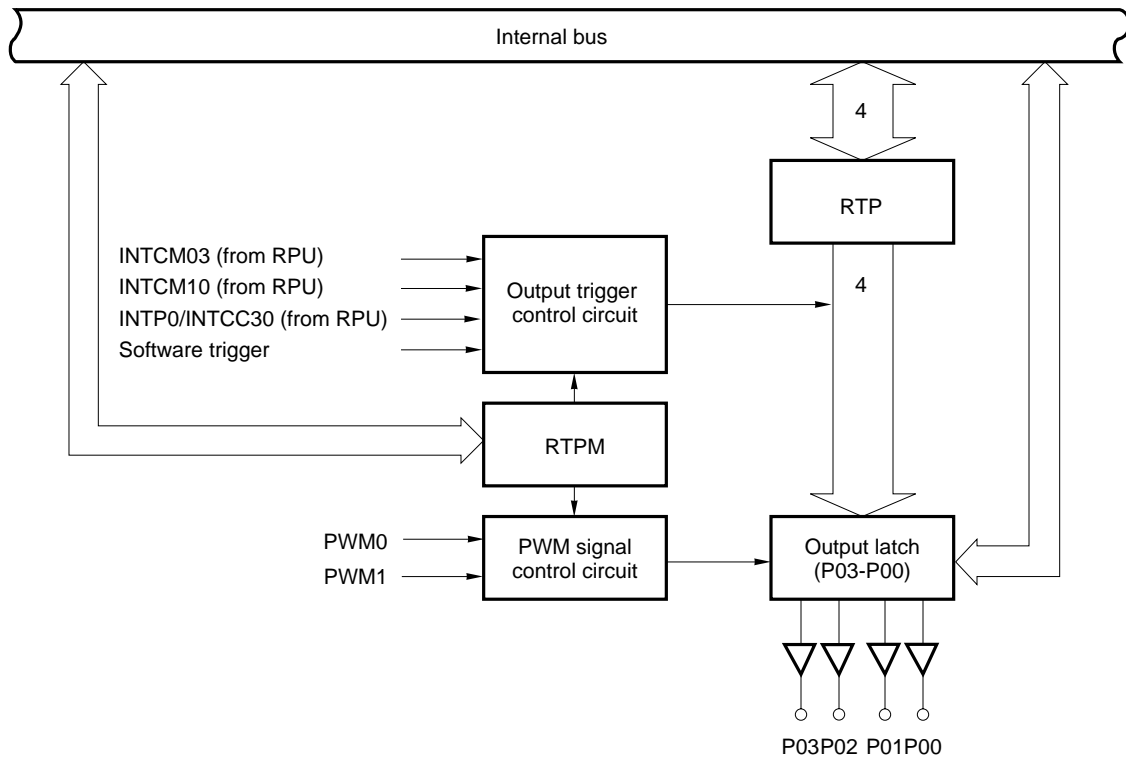
Remark f<sub>CLK</sub>: internal system clock

3.7 REAL-TIME OUTPUT PORT (RTP)

The real-time output port is a 4-bit port that can output the contents of the real-time output port register (RTP) in synchronization with the trigger signal from the real-time pulse unit (RPU). It can output synchronization pulses of multiple channels.

Also, PWM modulation can be applied to P00-P03.

Figure 3-13. Block Diagram of Real-Time Output Port

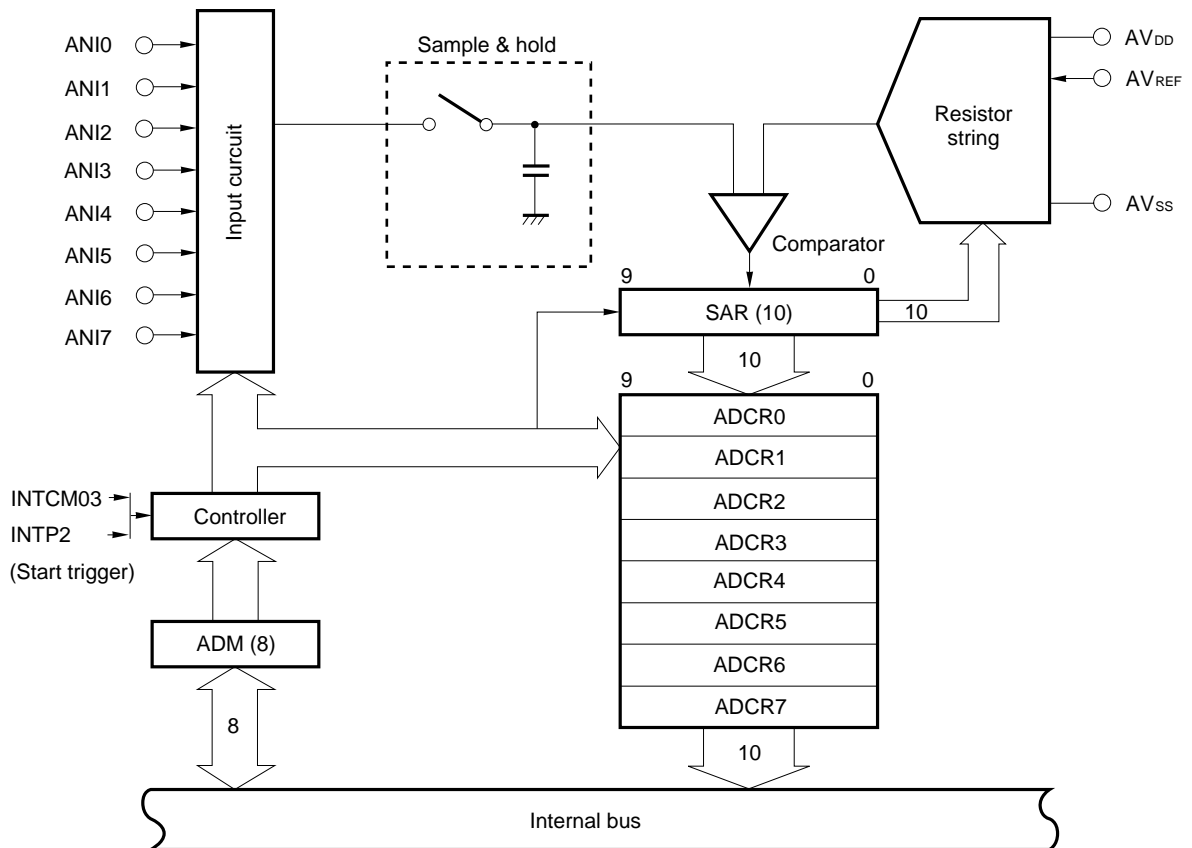


3.8 A/D CONVERTER

The μPD78366A contains a high-speed, high-resolution 10-bit analog-to-digital (A/D) converter (conversion time 12.6 μs at an internal clock frequency of 16 MHz). Successive approximation type is adopted. This converter is provided with eight analog input lines (ANI0-ANI7) and can perform various operations as the application requires, in select, scan, and mixed modes.

When A/D conversion ends, an internal interrupt (INTAD) occurs. This interrupt can start a macro service that executes automatic data transfer through hardware.

Figure 3-14. Block Diagram of A/D Converter



3.9 SERIAL INTERFACE

The μPD78366A is provided with the following two independent serial interfaces:

- Asynchronous serial interface (UART) (with pin selection function)
- Clocked serial interface
  - 3-line serial I/O mode
  - Serial bus interface mode (SBI mode)

Since the μPD78366A contains a baud rate generator (BRG), any serial transfer rate can be set regardless of the operating clock frequency. The baud rate generator is a block to generate the shift clock for the transmit/receive serial interface, and is used commonly with the two channels of the serial interfaces.

The serial transfer rate can be selected in a range of 110 bps to 38.4 Kbps by the mode register.

Figure 3-15. Block Diagram of Asynchronous Serial Interface

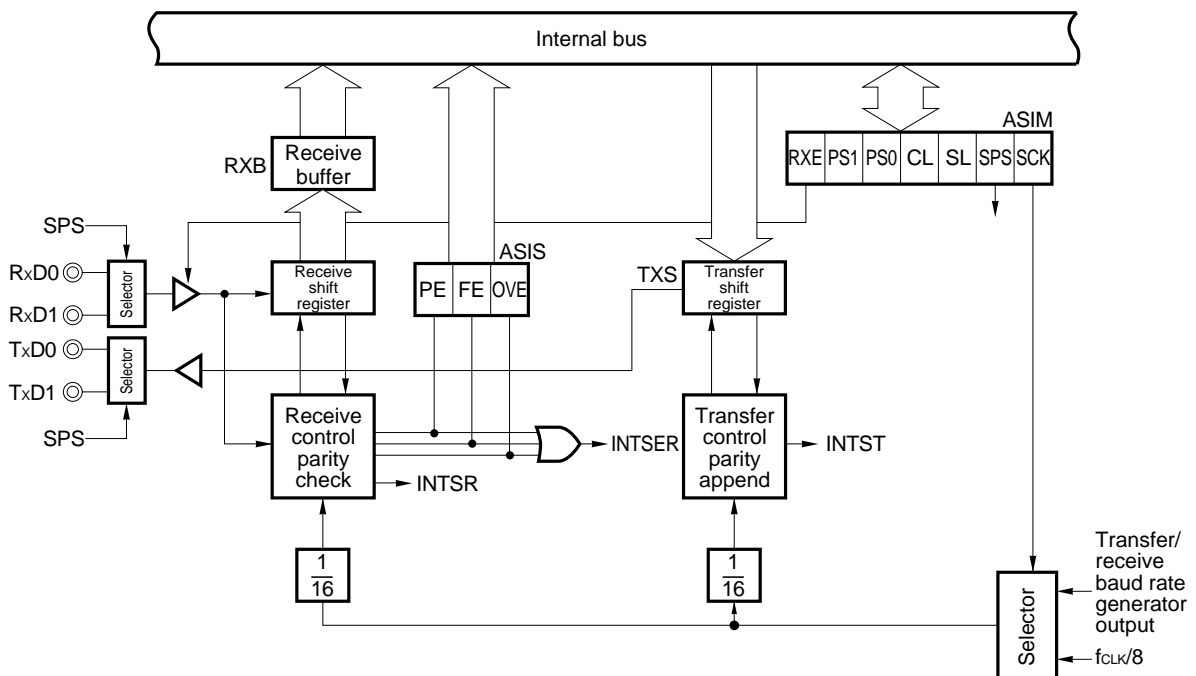


Figure 3-16. Block Diagram of Clocked Serial Interface

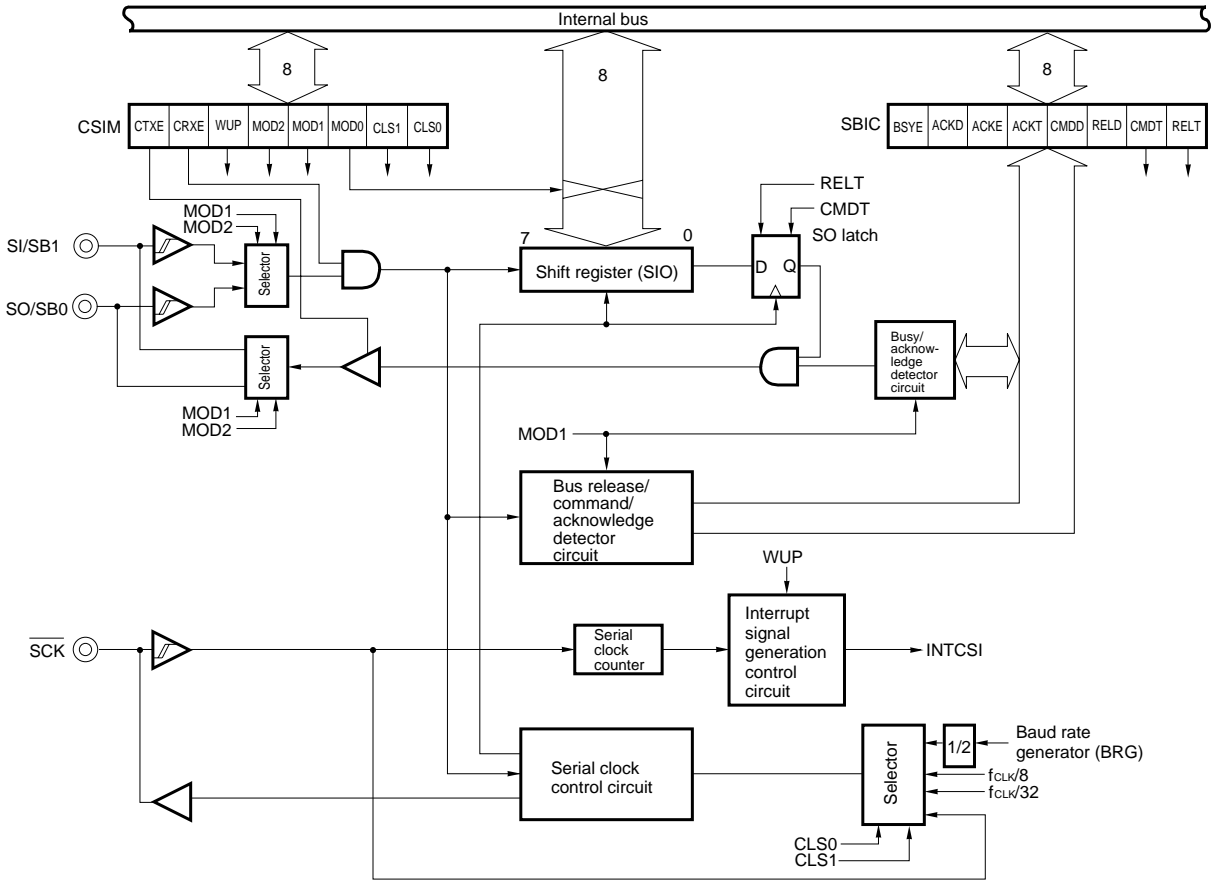
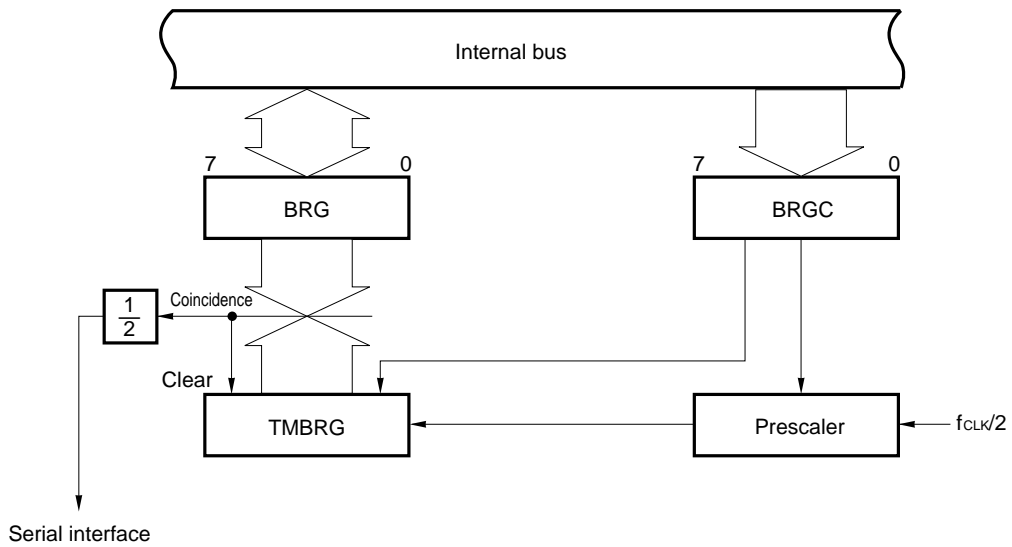


Figure 3-17. Block Diagram of Baud Rate Generator

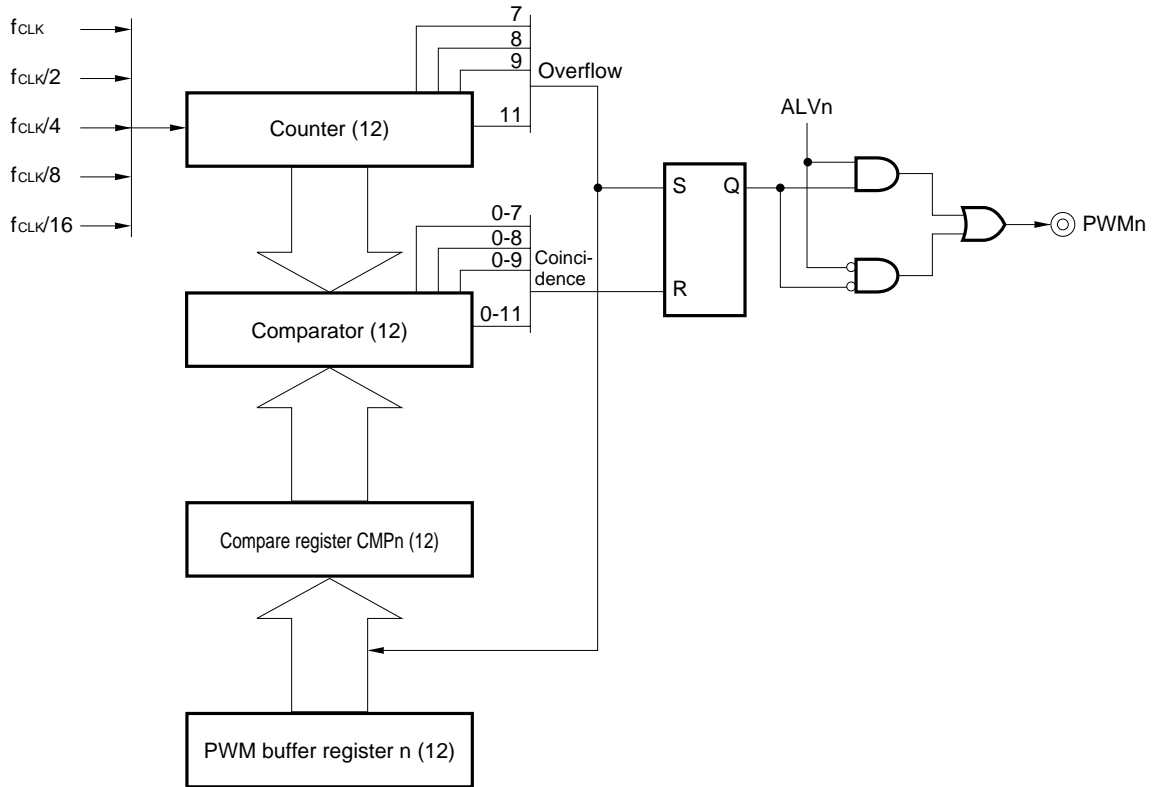


**3.10 PWM UNIT**

The  $\mu$ PD78366A is provided with two lines that output 8-/9-/10-/12-bit resolution variable PWM signals. The PWM output can be used as a digital-to-analog conversion output by connecting an external lowpass filter, and ideal for controlling actuators such as motors.

An output of between 244 Hz and 62.5 kHz can be obtained, depending on the combination of the count clock (62.5 ns to 1  $\mu$ s) and counter bit length (8, 9, 10, or 12) (at an internal clock frequency of 16 MHz).

**Figure 3-18. Block Diagram of PWM Unit**

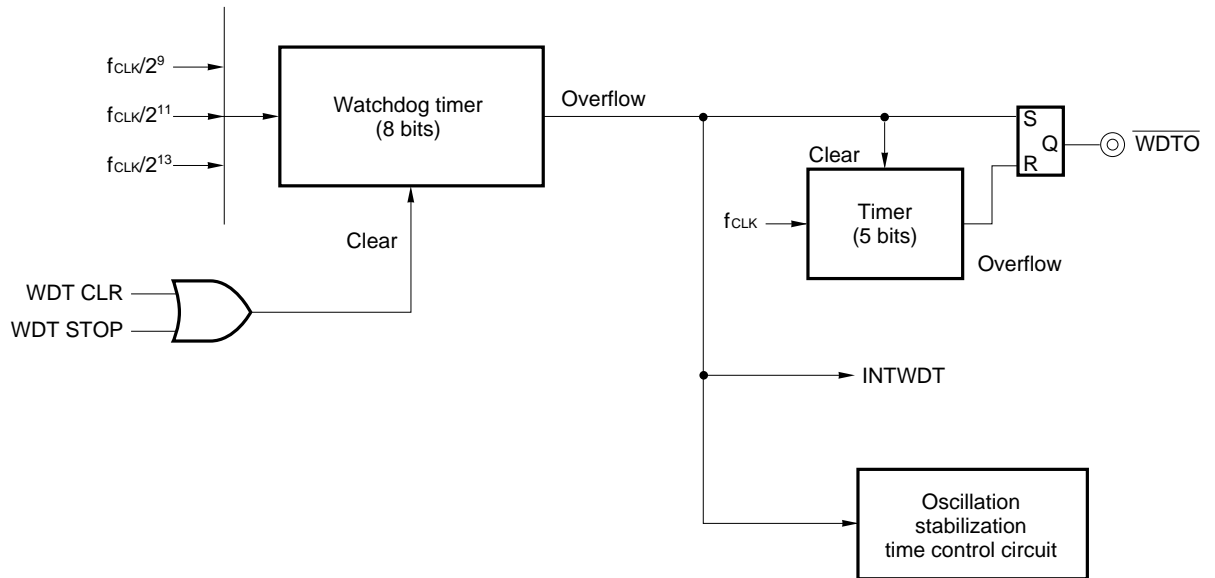


**Remark** n = 0, 1

**3.11 WATCHDOG TIMER (WDT)**

The watchdog timer is a free running timer equipped with a non-maskable interrupt function to prevent program hang-up or deadlock. When an error of the program is detected, the overflow interrupt (INTWDT) of the watchdog timer occurs and the watchdog timer output pin ( $\overline{\text{WDTO}}$ ) goes low. By connecting this output pin to the  $\overline{\text{RESET}}$  pin, any malfunctioning of the application system due to program error can be prevented.

**Figure 3-19. Block Diagram of Watchdog Timer**



4. INTERRUPT FUNCTIONS

4.1 OUTLINE

The μPD78366A is provided with powerful interrupt functions that can process interrupt requests from the internal hardware peripherals and external sources. In addition, the following three interrupt processing modes are available. In addition, four levels of interrupt priority can be specified.

- Vectored interrupt processing
- Macro service
- Context switching

Table 4-1. Interrupt Sources

Type	Note	Interrupt source		Source unit	Vector table address	Macro service	Context switching
		Name	Trigger				
Non-maskable	–	NMI	NMI pin input	External	0002H	None	None
	–	INTWDT	Watchdog timer	WDT	0004H		
Maskable	0	INTOV3	Overflow of timer 3	RPU	0006H	Provided	Provided
	1	INTP0/INTCC30	INTP0 pin input/CC30 coincidence signal	External/RPU	0008H		
	2	INTP1	INTP1 pin input	External	000AH		
	3	INTP2	INTP2 pin input		000CH		
	4	INTP3/INTCC20	INTP3 pin input/CC20 coincidence signal	External/RPU	000EH		
	5	INTP4	INTP4 pin input	External	0010H		
	6	INTTM0	Underflow of timer 0	RPU	0012H		
	7	INTCM03	CM03 coincidence signal		0014H		
	8	INTCM10	CM10 coincidence signal		0016H		
	9	INTCM40	CM40 coincidence signal		0018H		
	10	INTCM41	CM41 coincidence signal		001AH		
	11	INTSER	Receive error of UART	UART	001CH		
	12	INTSR	End of UART reception		001EH		
	13	INTST	End of UART transfer		0020H		
	14	INTCSI	End of CSI transfer/reception	CSI	0022H		
15	INTAD	End of A/D conversion	A/D	0024H			
Software	–	BRK	BRK instruction	–	003EH	None	None
	–	BRKCS	BRKCS instruction	–	–		Provided
Exception	–	TRAP	Illegal op code trap	–	003CH		None
Reset	–	RESET	Reset input	–	0000H		None

**Note** Default priority : Priority that takes precedence when two or more maskable interrupts occur at the same time. 0 is the highest priority, and 15 is the lowest.

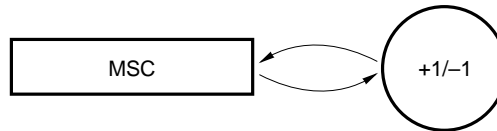


**4.2 MACRO SERVICE**

The μPD78366A has a total of five macro services. Each macro service is described below.

**(1) Counter mode: EVTCNT**

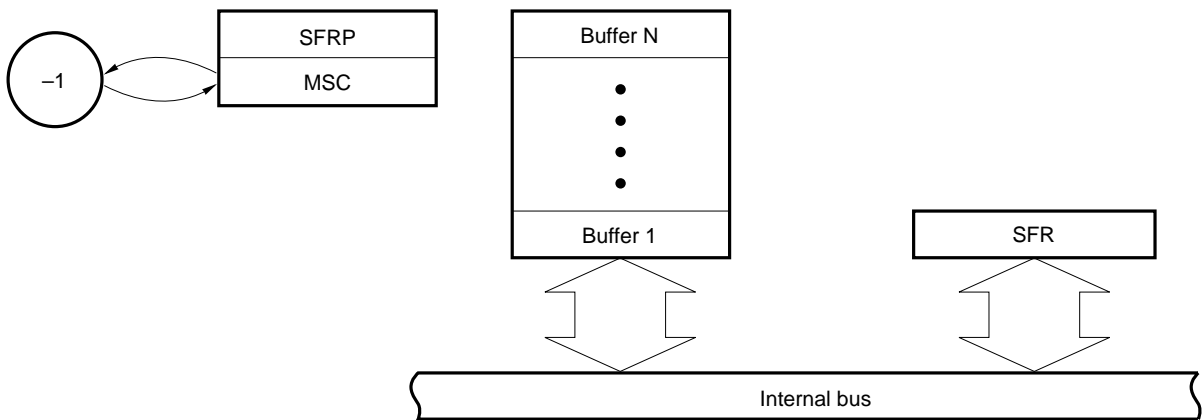
- Operation
  - (a) Increments or decrements an 8-bit macro service counter (MSC).
  - (b) A vector interrupt request is generated when MSC reaches 0.



- Application example: As event counter, or to measure number of times a value is captured

**(2) Block transfer mode: BLKTRS**

- Operation
  - (a) Transfers data block between a buffer and a SFR specified by SFR pointer (SFRP).
  - (b) The transfer source and destination can be in SFR or buffer area. The length of the transfer data can be specified to be byte or word.
  - (c) The number of times the data is to be transferred (block size) is specified by MSC.
  - (d) MSC is auto decremented by one each time the macro service has been executed.
  - (e) When MSC reaches 0, a vector interrupt request is generated.



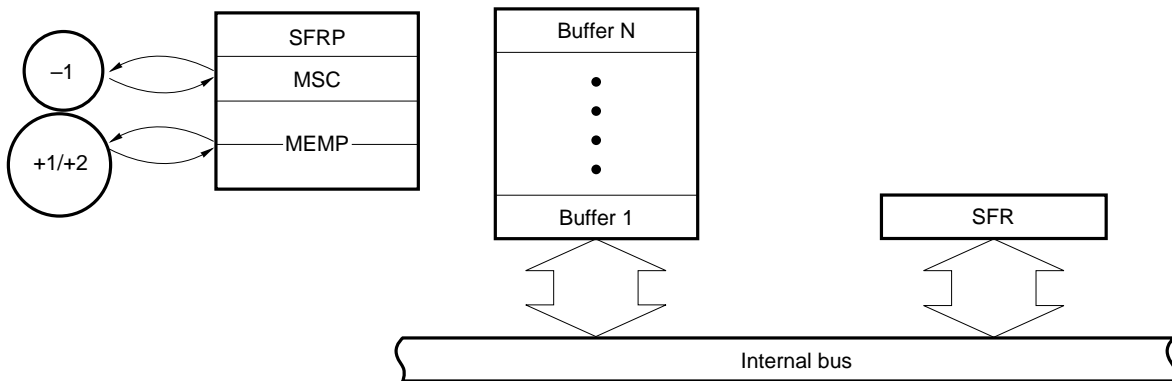
- Application example: To transfer/receive data through serial interface

**(3) Block transfer mode (with memory pointer): BLKTRS-P**

- Operation

This is the block transfer mode in (2) above with a memory pointer (MEMP). The appended buffer area of MEMP can be freely set on the memory space.

**Remark** Each time the macro service is executed, MEMP is auto incremented (by one for byte data transfer and by two for word data transfer).



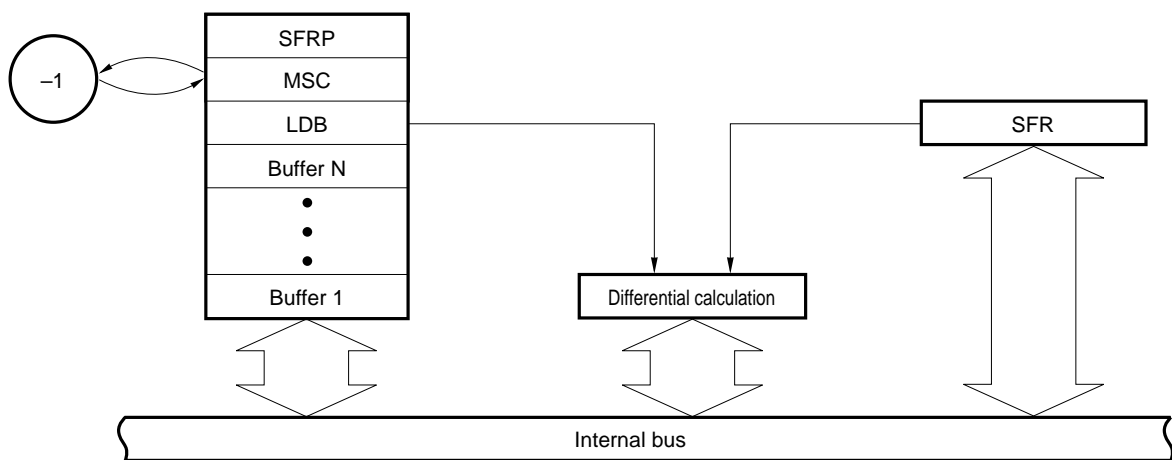
- Application example: Same as (2)

**(4) Data differential mode: DTADIF**

- Operation

- Calculates the difference between the contents of SFR (current value) specified by SFRP and the contents of SFR saved to the last data buffer (LDB).
- Stores the result of the calculation in a predetermined buffer area.
- Stores the contents of the current value of the SFR in LDB.
- The number of times the data is to be transferred (block size) is specified by MSC. Each time the macro service is executed, MSC is auto decremented by one.
- When MSC reaches 0, a vector interrupt request is generated.

**Remark** The differential calculation can be carried out only with 16-bit SFRs.



- Application example : To measure cycle and pulse width by the capture register of the real-time pulse unit (RPU)

**(5) Data differential mode (with memory pointer): DTADIF-P**

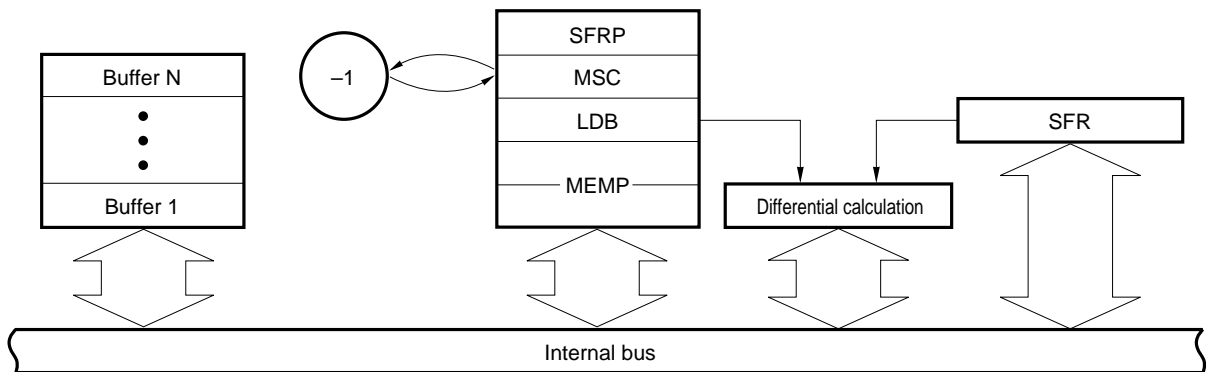
- Operation

This is the data differential mode in (4) above with memory pointer (MEMP). By appending MEMP, the buffer area in which the differential data is to be stored can be set freely on the memory space.

**Remarks**

1. The differential calculation can be carried out only with 16-bit SFRs.
2. The buffer is specified by the result of operation by MEMP and MSC<sup>Note</sup>. MEMP is not updated after the data has been transferred.

**Note**  $MEMP - (MSC \times 2) + 2$



- Application example: Same as (4)

**4.3 CONTEXT SWITCHING**

This function is to select a specific register bank through the hardware, and to branch execution to a vector address predetermined in the register bank. At the same time, it saves the present contents of the PC and PSW to the register bank when an interrupt occurs, or when the BRKCS instruction is executed.

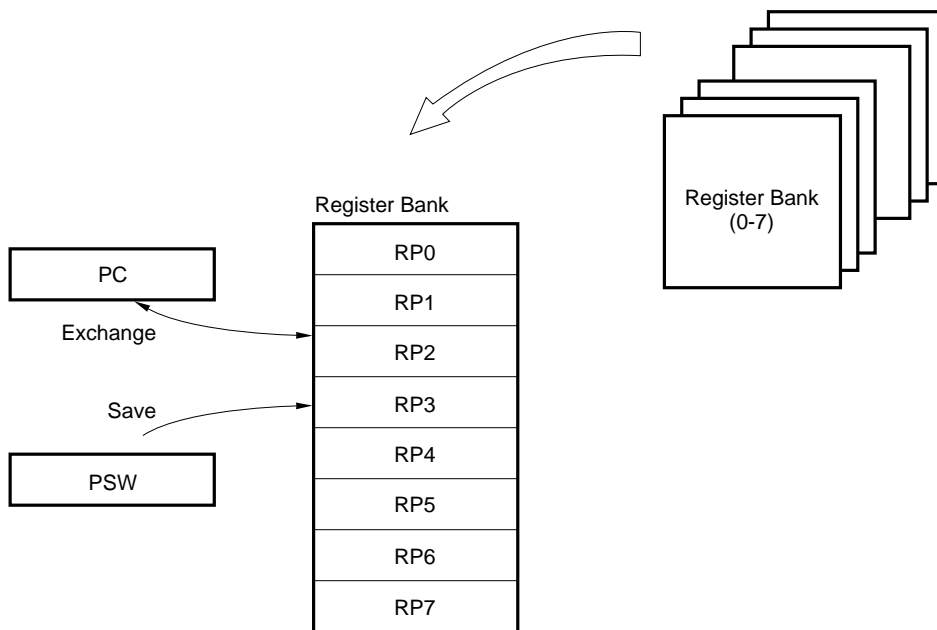
**4.3.1 Context Switching Function by Interrupt Request**

When a context switching enable flag corresponding to each maskable interrupt request is set to 1 in the EI (interrupt enable) status, the context switching function can be started.

The context switching operation by an interrupt request is performed as follows:

- (1) When an interrupt request is generated, a register bank to which the context is to be switched is specified by the contents of the low-order 3 bits of the row address (even address) of the corresponding vector table.
- (2) A predetermined vector address is transferred to the PC in the register bank to which the context is to be switched, and the contents of the PC and PSW immediately before the switching takes place are saved to the register bank.
- (3) Execution branches to an address indicated by the contents of the PC newly set.

**Figure 4-1. Operation of Context Switching**



**4.3.2 Context Switching Function by BRKCS Instruction**

The context switching function can be started by the BRKCS instruction.

The operation of context switching by an interrupt request is as follows:

- (1) An 8-bit register is specified by the operand of the BRKCS instruction, and the register bank to which the context is to be switched is specified by the contents of this register (only the low-order 3 bits of 8 bits are valid).
- (2) The vector address predetermined in the register bank to which the context is to be switched is transferred to the PC, and at the same time, the contents of the PC and PSW immediately before the switching takes place are saved to the register bank.
- (3) Execution branches to the contents of the PC newly set.

**4.3.3 Restoration from Context Switching**

To restore from the switched context, one of the following two instructions are used. Which instruction is to be executed is determined by the source that has started the context switching.

**Table 4-2. Instructions to Restore from Context Switching**

Restore instruction	Context switching starting source
RETCS	Occurrence of interrupt
RETCSB	Execution of BRKCS instruction

5. EXTERNAL DEVICE EXPANSION FUNCTION

The μPD78366A can connect external devices (data memory, program memory, and peripheral devices) in addition to the internal ROM and RAM areas. To connect an external device, the address/data bus and read/write strobe signals are controlled by using ports 4, 5, and 9.

**Table 5-1. Pin Function with External Device Connected**

Pin	Pin function with external device connected	
	Function	Name
P40-P47	Multiplexed address/data bus	AD0-AD7
P50-P57	Address bus	A8-A15
P90	Read strobe	$\overline{RD}$
P91	Write strobe	$\overline{WR}$
ASTB	Address strobe	ASTB

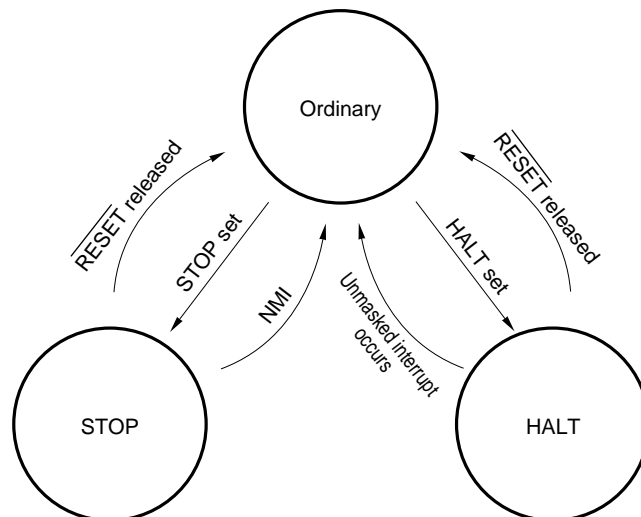
6. STANDBY FUNCTIONS

The μPD78366A is provided with standby functions to reduce the power consumption of the system. The standby functions can be effected in the following two modes:

- HALT mode ..... In this mode, the operating clock of the CPU is stopped. By using this mode in combination with an ordinary operation mode, the μPD78366A operates intermittently to reduce the total power consumption of the system.
- STOP mode .... In this mode, the oscillator is stopped, and therefore the entire system is stopped. Therefore, power consumption can be minimized with only a leakage current flowing.

Each mode is set through software. Figure 6-1 shows the transition of the status in the standby modes (STOP and HALT modes).

Figure 6-1. Transition of Standby Status



7. RESET FUNCTION

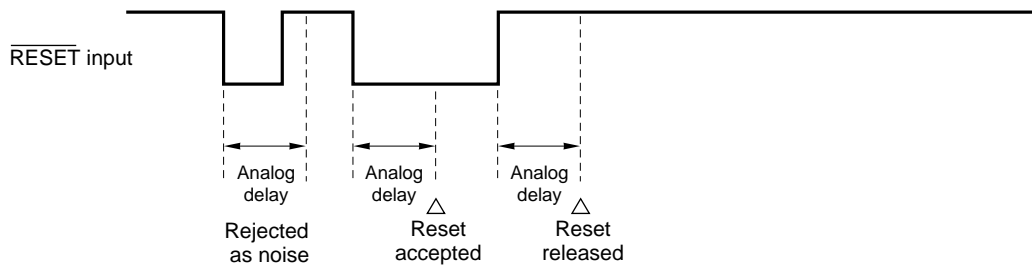
When a low level is input to the  $\overline{\text{RESET}}$  pin, the system is reset, and each hardware enters the initial status (reset status). When the  $\overline{\text{RESET}}$  pin goes high, the reset status is released, and program execution is started. Initialize the contents of each register through program as necessary.

Especially, change the number of cycles of the programmable wait control register as necessary.

The  $\overline{\text{RESET}}$  pin is equipped with a noise rejecter circuit of analog delay to prevent malfunctioning due to noise.

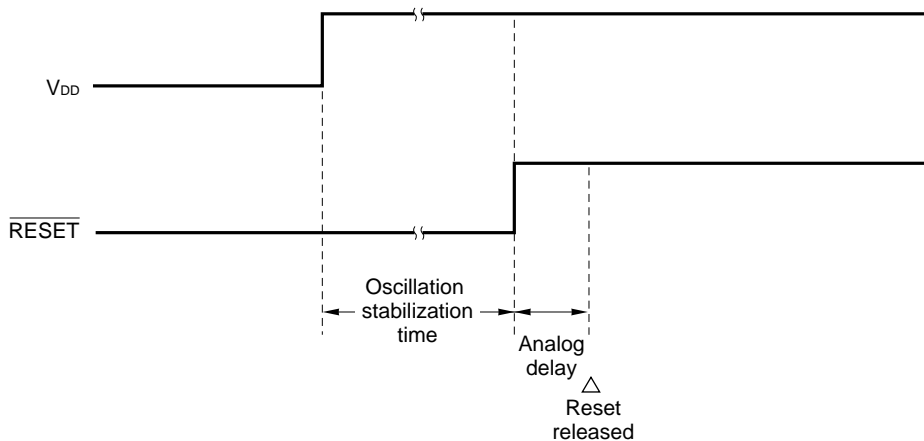
- Cautions**
1. While the  $\overline{\text{RESET}}$  pin is active (low level), all the pins go into a high-impedance state (except  $\overline{\text{WDTO}}$ ,  $\text{AV}_{\text{REF}}$ ,  $\text{AV}_{\text{DD}}$ ,  $\text{AV}_{\text{SS}}$ ,  $\text{V}_{\text{DD}}$ ,  $\text{V}_{\text{SS}}$ , X1, and X2 pins).
  2. When an external RAM is connected, do not connect a pull-up resistor to the P90/ $\overline{\text{RD}}$  and P91/ $\overline{\text{WR}}$  pins, because the P90/ $\overline{\text{RD}}$  and P91/ $\overline{\text{WR}}$  pins may go into a high-impedance state, resulting in destruction of the contents of the external RAM. In addition, signal contention occurs on the address/data bus, resulting in damage to the input/output circuit.

Figure 7-1. Accepting Reset Signal



To effect reset on when power is applied, make sure that sufficient time elapses to stabilize the oscillation after the power is applied until the reset signal is accepted, as shown in Figure 7-2.

Figure 7-2. Reset on Power Application





8. INSTRUCTION SET

Write an operand in the operand field of each instruction according to the description of the instruction (for details, refer to the Assembler Specifications). Some instructions have two or more operands. Select one of them. Uppercase characters, +, -, #, \$, !, [, and ] are keywords and must be written as is.

Write an appropriate numeric value or label as immediate data. To write a label, be sure to write #, \$, !, [, or ].

Table 8-1. Operand Representation and Description

Representation	Description
r	R0, R1, R2, R3, R4, R5, R6, R7, R8, R9, R10, R11, R12, R13, R14, R15
r1	R0, R1, R2, R3, R4, R5, R6, R7
r2	C, B
rp	RP0, RP1, RP2, RP3, RP4, RP5, RP6, RP7
rp1	RP0, RP1, RP2, RP3, RP4, RP5, RP6, RP7
rp2	DE, HL, VP, UP
sfr	Special function register symbol (Refer to <b>Table 2-1.</b> )
sfrp	Special function register symbol (register that can be manipulated in 16-bit units. Refer to <b>Table 2-1.</b> )
post	RP0, RP1, RP2, RP3, RP4, RP5/PSW, RP6, RP7 (More than one symbol can be written. However, RP5 can be written only for PUSH and POP instructions, and PSW can be written only for PUSHU and POPU instructions.)
mem	[DE], [HL], [DE+], [HL+], [DE-], [HL-], [VP], [UP] ; register indirect mode [DE + A], [HL + A], [DE + B], [HL + B], [VP + DE], [VP + HL] ; based indexed mode [DE + byte], [HL + byte], [VP + byte], [UP + byte], [SP + byte] ; based mode word[A], word[B], word[DE], word[HL] ; indexed mode
saddr	FE20H-FF1FH immediate data or label
saddrp	FE20H-FF1EH immediate data (however, bit0 = 0) or label (manipulated in 16-bit units)
\$ addr16	0000H-FDFFFH immediate data or label; relative addressing
! addr16	0000H-FDFFFH immediate data or label; immediate addressing (However, up to FFFFH can be written for MOV instruction. Only FE00H-FEFFFH can be written for MOVTBLW instruction.)
addr11	800H-FFFH immediate data or label
addr5	40H-7EH immediate data (however, bit0 = 0) <sup>Note</sup> or label
word	16-bit immediate data or label
byte	8-bit immediate data or label
bit	3-bit immediate data or label
n	3-bit immediate data (0-7)

**Note** Do not access bit0 = 1 (odd address) in word units.

- Remarks**
1. rp and rp1 are the same in terms of register name that can be written but are different in code to be generated.
  2. r, r1, rp, rp1, and post can be written in absolute name (R0-R15, RP0-RP7) and function name (X, A, C, B, E, D, L, H, AX, BC, DE, HL, VP, and UP).
  3. Immediate addressing can address the entire space. Relative addressing can address only a range of -128 to +127 from the first address of the next instruction.

Instructions	Mnemonic	Operand	Byte	Operation	Flag					
					S	Z	AC	P/V	CY	
8-bit data transfer	MOV	r1, #byte	2	r1 ← byte						
		saddr, #byte	3	(saddr) ← byte						
		sfr <sup>Note</sup> , #byte	3	sfr ← byte						
		r, r1	2	r ← r1						
		A, r1	1	A ← r1						
		A, saddr	2	A ← (saddr)						
		saddr, A	2	(saddr) ← A						
		saddr, saddr	3	(saddr) ← (saddr)						
		A, sfr	2	A ← sfr						
		sfr, A	2	sfr ← A						
		A, mem	1-4	A ← (mem)						
		mem, A	1-4	(mem) ← A						
		A, [saddrp]	2	A ← ((saddrp))						
		[saddrp], A	2	((saddrp)) ← A						
		A, !addr16	4	A ← (addr16)						
		!addr16, A	4	(addr16) ← A						
		PSWL, #byte	3	PSWL ← byte			x	x	x	x
		PSWH, #byte	3	PSWH ← byte						
		PSWL, A	2	PSWL ← A			x	x	x	x
		PSWH, A	2	PSWH ← A						
	A, PSWL	2	A ← PSWL							
	A, PSWH	2	A ← PSWH							
	XCH	A, r1	1	A ↔ r1						
		r, r1	2	r ↔ r1						
		A, mem	2-4	A ↔ (mem)						
		A, saddr	2	A ↔ (saddr)						
		A, sfr	3	A ↔ sfr						
		A, [saddrp]	2	A ↔ ((saddrp))						
saddr, saddr		3	(saddr) ↔ (saddr)							

**Note** When STBC or WDM is written as sfr, this instruction is treated as a dedicated instruction whose number of bytes is different from that of this instruction.

**Remark** For symbols in flag, refer to the table below.

Symbol	Remarks
(Blank)	No change
0	Cleared to 0
1	Set to 1
x	Set/cleared according to result
P	P/V flag functions as parity flag
V	P/V flag operates as overflow flag
R	Value previously saved is restored

Instructions	Mnemonic	Operand	Byte	Operation	Flag				
					S	Z	AC	P/V	CY
16-bit data transfer	<b>MOVW</b>	rp1, #word	3	rp1 ← word					
		saddrp, #word	4	(saddrp) ← word					
		sfrp, #word	4	sfrp ← word					
		rp, rp1	2	rp ← rp1					
		AX, saddrp	2	AX ← (saddrp)					
		saddrp, AX	2	(saddrp) ← AX					
		saddrp, saddrp	3	(saddrp) ← (saddrp)					
		AX, sfrp	2	AX ← sfrp					
		sfrp, AX	2	sfrp ← AX					
		rp1, !addr16	4	rp1 ← (addr16)					
		!addr16, rp1	4	(addr16) ← rp1					
		AX, mem	2-4	AX ← (mem)					
	mem, AX	2-4	(mem) ← AX						
	<b>XCHW</b>	AX, saddrp	2	AX ↔ (saddrp)					
		AX, sfrp	3	AX ↔ sfrp					
		saddrp, saddrp	3	(saddrp) ↔ (saddrp)					
		rp, rp1	2	rp ↔ rp1					
		AX, mem	2-4	AX ↔ (mem)					
8-bit operation	<b>ADD</b>	A, #byte	2	A, CY ← A + byte	×	×	×	V	×
		saddr, #byte	3	(saddr), CY ← (saddr) + byte	×	×	×	V	×
		sfr, #byte	4	sfr, CY ← sfr + byte	×	×	×	V	×
		r, r1	2	r, CY ← r + r1	×	×	×	V	×
		A, saddr	2	A, CY ← A + (saddr)	×	×	×	V	×
		A, sfr	3	A, CY ← A + sfr	×	×	×	V	×
		saddr, saddr	3	(saddr), CY ← (saddr) + (saddr)	×	×	×	V	×
		A, mem	2-4	A, CY ← A + (mem)	×	×	×	V	×
		mem, A	2-4	(mem), CY ← (mem) + A	×	×	×	V	×
	<b>ADDC</b>	A, #byte	2	A, CY ← A + byte + CY	×	×	×	V	×
		saddr, #byte	3	(saddr), CY ← (saddr) + byte + CY	×	×	×	V	×
		sfr, #byte	4	sfr, CY ← sfr + byte + CY	×	×	×	V	×
		r, r1	2	r, CY ← r + r1 + CY	×	×	×	V	×
		A, saddr	2	A, CY ← A + (saddr) + CY	×	×	×	V	×
		A, sfr	3	A, CY ← A + sfr + CY	×	×	×	V	×
		saddr, saddr	3	(saddr), CY ← (saddr) + (saddr) + CY	×	×	×	V	×
		A, mem	2-4	A, CY ← A + (mem) + CY	×	×	×	V	×
		mem, A	2-4	(mem), CY ← (mem) + A + CY	×	×	×	V	×

Instructions	Mnemonic	Operand	Byte	Operation	Flag				
					S	Z	AC	P/V	CY
8-bit operation	<b>SUB</b>	A, #byte	2	$A, CY \leftarrow A - \text{byte}$	×	×	×	V	×
		saddr, #byte	3	$(\text{saddr}), CY \leftarrow (\text{saddr}) - \text{byte}$	×	×	×	V	×
		sfr, #byte	4	$\text{sfr}, CY \leftarrow \text{sfr} - \text{byte}$	×	×	×	V	×
		r, r1	2	$r, CY \leftarrow r - r1$	×	×	×	V	×
		A, saddr	2	$A, CY \leftarrow A - (\text{saddr})$	×	×	×	V	×
		A, sfr	3	$A, CY \leftarrow A - \text{sfr}$	×	×	×	V	×
		saddr, saddr	3	$(\text{saddr}), CY \leftarrow (\text{saddr}) - (\text{saddr})$	×	×	×	V	×
		A, mem	2-4	$A, CY \leftarrow A - (\text{mem})$	×	×	×	V	×
		mem, A	2-4	$(\text{mem}), CY \leftarrow (\text{mem}) - A$	×	×	×	V	×
	<b>SUBC</b>	A, #byte	2	$A, CY \leftarrow A - \text{byte} - CY$	×	×	×	V	×
		saddr, #byte	3	$(\text{saddr}), CY \leftarrow (\text{saddr}) - \text{byte} - CY$	×	×	×	V	×
		sfr, #byte	4	$\text{sfr}, CY \leftarrow \text{sfr} - \text{byte} - CY$	×	×	×	V	×
		r, r1	2	$r, CY \leftarrow r - r1 - CY$	×	×	×	V	×
		A, saddr	2	$A, CY \leftarrow A - (\text{saddr}) - CY$	×	×	×	V	×
		A, sfr	3	$A, CY \leftarrow A - \text{sfr} - CY$	×	×	×	V	×
		saddr, saddr	3	$(\text{saddr}), CY \leftarrow (\text{saddr}) - (\text{saddr}) - CY$	×	×	×	V	×
		A, mem	2-4	$A, CY \leftarrow A - (\text{mem}) - CY$	×	×	×	V	×
		mem, A	2-4	$(\text{mem}), CY \leftarrow (\text{mem}) - A - CY$	×	×	×	V	×
	<b>AND</b>	A, #byte	2	$A \leftarrow A \wedge \text{byte}$	×	×		P	
		saddr, #byte	3	$(\text{saddr}) \leftarrow (\text{saddr}) \wedge \text{byte}$	×	×		P	
		sfr, #byte	4	$\text{sfr} \leftarrow \text{sfr} \wedge \text{byte}$	×	×		P	
		r, r1	2	$r \leftarrow r \wedge r1$	×	×		P	
		A, saddr	2	$A \leftarrow A \wedge (\text{saddr})$	×	×		P	
		A, sfr	3	$A \leftarrow A \wedge \text{sfr}$	×	×		P	
		saddr, saddr	3	$(\text{saddr}) \leftarrow (\text{saddr}) \wedge (\text{saddr})$	×	×		P	
		A, mem	2-4	$A \leftarrow A \wedge (\text{mem})$	×	×		P	
		mem, A	2-4	$(\text{mem}) \leftarrow (\text{mem}) \wedge A$	×	×		P	

Instructions	Mnemonic	Operand	Byte	Operation	Flag				
					S	Z	AC	P/V	CY
8-bit operation	<b>OR</b>	A, #byte	2	$A \leftarrow A \vee \text{byte}$	×	×		P	
		saddr, #byte	3	$(\text{saddr}) \leftarrow (\text{saddr}) \vee \text{byte}$	×	×		P	
		sfr, #byte	4	$\text{sfr} \leftarrow \text{sfr} \vee \text{byte}$	×	×		P	
		r, r1	2	$r, \leftarrow r \vee r1$	×	×		P	
		A, saddr	2	$A \leftarrow A \vee (\text{saddr})$	×	×		P	
		A, sfr	3	$A \leftarrow A \vee \text{sfr}$	×	×		P	
		saddr, saddr	3	$(\text{saddr}) \leftarrow (\text{saddr}) \vee (\text{saddr})$	×	×		P	
		A, mem	2-4	$A \leftarrow A \vee (\text{mem})$	×	×		P	
		mem, A	2-4	$(\text{mem}) \leftarrow (\text{mem}) / A$	×	×		P	
	<b>XOR</b>	A, #byte	2	$A \leftarrow A \nabla \text{byte}$	×	×		P	
		saddr, #byte	3	$(\text{saddr}) \leftarrow (\text{saddr}) \nabla \text{byte}$	×	×		P	
		sfr, #byte	4	$\text{sfr} \leftarrow \text{sfr} \nabla \text{byte}$	×	×		P	
		r, r1	2	$r \leftarrow r \nabla r1$	×	×		P	
		A, saddr	2	$A \leftarrow A \nabla (\text{saddr})$	×	×		P	
		A, sfr	3	$A \leftarrow A \nabla \text{sfr}$	×	×		P	
		saddr, saddr	3	$(\text{saddr}) \leftarrow (\text{saddr}) \nabla (\text{saddr})$	×	×		P	
		A, mem	2-4	$A \leftarrow A \nabla (\text{mem})$	×	×		P	
		mem, A	2-4	$(\text{mem}) \leftarrow (\text{mem}) \nabla A$	×	×		P	
	<b>CMP</b>	A, #byte	2	$A - \text{byte}$	×	×	×	V	×
		saddr, #byte	3	$(\text{saddr}) - \text{byte}$	×	×	×	V	×
		sfr, #byte	4	$\text{sfr} - \text{byte}$	×	×	×	V	×
		r, r1	2	$r - r1$	×	×	×	V	×
		A, saddr	2	$A - (\text{saddr})$	×	×	×	V	×
		A, sfr	3	$A - \text{sfr}$	×	×	×	V	×
		saddr, saddr	3	$(\text{saddr}) - (\text{saddr})$	×	×	×	V	×
		A, mem	2-4	$A - (\text{mem})$	×	×	×	V	×
		mem, A	2-4	$(\text{mem}) - A$	×	×	×	V	×

Instructions	Mnemonic	Operand	Byte	Operation	Flag					
					S	Z	AC	P/V	CY	
16-bit operation	<b>ADDW</b>	AX, #word	3	AX, CY ← AX + word	×	×	×	V	×	
		saddrp, #word	4	(saddrp), CY ← (saddrp) + word	×	×	×	V	×	
		sfrp, #word	5	sfrp, CY ← sfrp + word	×	×	×	V	×	
		rp, rp1	2	rp, CY ← rp + rp1	×	×	×	V	×	
		AX, saddrp	2	AX, CY ← AX + (saddrp)	×	×	×	V	×	
		AX, sfrp	3	AX, CY ← AX + sfrp	×	×	×	V	×	
		saddrp, saddrp	3	(saddrp), CY ← (saddrp) + (saddrp)	×	×	×	V	×	
	<b>SUBW</b>	AX, #word	3	AX, CY ← AX – word	×	×	×	V	×	
		saddrp, #word	4	(saddrp), CY ← (saddrp) – word	×	×	×	V	×	
		sfrp, #word	5	sfrp, CY ← sfrp – word	×	×	×	V	×	
		rp, rp1	2	rp, CY ← rp – rp1	×	×	×	V	×	
		AX, saddrp	2	AX, CY ← AX – (saddrp)	×	×	×	V	×	
		AX, sfrp	3	AX, CY ← AX – sfrp	×	×	×	V	×	
		saddrp, saddrp	3	(saddrp), CY ← (saddrp) – (saddrp)	×	×	×	V	×	
	<b>CMPW</b>	AX, #word	3	AX – word	×	×	×	V	×	
		saddrp, #word	4	(saddrp) – word	×	×	×	V	×	
		sfrp, #word	5	sfrp – word	×	×	×	V	×	
		rp, rp1	2	rp – rp1	×	×	×	V	×	
		AX, saddrp	2	AX – (saddrp)	×	×	×	V	×	
		AX, sfrp	3	AX – sfrp	×	×	×	V	×	
		saddrp, saddrp	3	(saddrp) – (saddrp)	×	×	×	V	×	
Multiplication /division	<b>MULU</b>	r1	2	AX ← AX × r1						
	<b>DIVUW</b>	r1	2	AX (quotient), r1 (remainder) ← AX ÷ r1						
	<b>MULUW</b>	rp1	2	AX (high-order 16 bits), rp1 (low-order 16 bits) ← AX × rp1						
	<b>DIVUX</b>	rp1	2	AXDE (quotient), rp1 (remainder) ← AXDE ÷ rp1						
Signed multiplication	<b>MULW</b>	rp1	2	AX (high-order 16 bits), rp1 (low-order 16 bits) ← AX × rp1						
Sum-of-products operation	<b>MACW</b>	n	3	AXDE ← (B) × (C) + AXDE B ← B + 2, C ← C + 2, n ← n – 1 End if n = 0 or P/V = 1	×	×	×	V	×	
Sum-of-products operation with saturation	<b>MACSW</b>	n	3	AXDE ← (B) × (C) + AXDE B ← B + 2, C ← C + 2, n ← n – 1 if overflow (P/V = 1) then AXDE ← 7FFFFFFFH if underflow (P/V = 1) then AXDE ← 80000000H end if n = 0 or P/V = 1	×	×	×	V	×	
Relative operation	<b>SACW</b>	[DE + ], [HL + ]	4	AX ← AX +   (DE) – (HL)   DE ← DE + 2 HL ← HL + 2 C ← C – 1 end if C = 0 or cy = 1	×	×	×	V	×	

Instructions	Mnemonic	Operand	Byte	Operation	Flag					
					S	Z	AC	P/V	CY	
Table shift	<b>MOVTBLW</b>	laddr16, n	4	$(addr16 + 2) \leftarrow (addr16), n \leftarrow n - 1$ $addr16 \leftarrow addr16 - 2, \text{ End if } n = 0$						
Increment/decrement	<b>INC</b>	r1	1	$r1 \leftarrow r1 + 1$	×	×	×	V		
		saddr	2	$(saddr) \leftarrow (saddr) + 1$	×	×	×	V		
	<b>DEC</b>	r1	1	$r1 \leftarrow r1 - 1$	×	×	×	V		
		saddr	2	$(saddr) \leftarrow (saddr) - 1$	×	×	×	V		
	<b>INCW</b>	rp2	1	$rp2 \leftarrow rp2 + 1$						
		saddrp	3	$(saddrp) \leftarrow (saddrp) + 1$						
<b>DECW</b>	rp2	1	$rp2 \leftarrow rp2 - 1$							
	saddrp	3	$(saddrp) \leftarrow (saddrp) - 1$							
Shift rotate	<b>ROR</b>	r1, n	2	$(CY, r1_7 \leftarrow r1_0, r1_{m-1} \leftarrow r1_m) \times n \text{ times}$				P	×	
	<b>ROL</b>	r1, n	2	$(CY, r1_0 \leftarrow r1_7, r1_{m+1} \leftarrow r1_m) \times n \text{ times}$				P	×	
	<b>RORC</b>	r1, n	2	$(CY \leftarrow r1_0, r1_7 \leftarrow CY, r1_{m-1} \leftarrow r1_m) \times n \text{ times}$				P	×	
	<b>ROLC</b>	r1, n	2	$(CY \leftarrow r1_7, r1_0 \leftarrow CY, r1_{m+1} \leftarrow r1_m) \times n \text{ times}$				P	×	
	<b>SHR</b>	r1, n	2	$(CY \leftarrow r1_0, r1_7 \leftarrow 0, r1_{m-1} \leftarrow r1_m) \times n \text{ times}$	×	×	0	P	×	
	<b>SHL</b>	r1, n	2	$(CY \leftarrow r1_7, r1_0 \leftarrow 0, r1_{m+1} \leftarrow r1_m) \times n \text{ times}$	×	×	0	P	×	
	<b>SHRW</b>	rp1, n	2	$(CY \leftarrow rp1_0, rp1_{15} \leftarrow 0, rp1_{m-1} \leftarrow rp1_m) \times n \text{ times}$	×	×	0	P	×	
	<b>SHLW</b>	rp1, n	2	$(CY \leftarrow rp1_{15}, rp1_0 \leftarrow 0, rp1_{m+1} \leftarrow rp1_m) \times n \text{ times}$	×	×	0	P	×	
	<b>ROR4</b>	[rp1]	2	$A_{3-0} \leftarrow (rp1)_{3-0},$ $(rp1)_{7-4} \leftarrow A_{3-0},$ $(rp1)_{3-0} \leftarrow (rp1)_{7-4}$						
	<b>ROL4</b>	[rp1]	2	$A_{3-0} \leftarrow (rp1)_{7-4},$ $(rp1)_{3-0} \leftarrow A_{3-0},$ $(rp1)_{7-4} \leftarrow (rp1)_{3-0}$						
BCD adjustment	<b>ADJBA</b>		2	Decimal Adjust Accumelator	×	×	0	P	×	
	<b>ADJBS</b>									
Data conversion	<b>CVTBW</b>		1	When $A_7 = 0, X \leftarrow A, A \leftarrow 00H$ When $A_7 = 1, X \leftarrow A, A \leftarrow FFH$						

**Remarks** 1. n of the shift rotate instruction indicates the number of times the shift rotate instruction is executed.

2. The address of the table shift instruction ranges from FE00H to FEFFH.

Instructions	Mnemonic	Operand	Byte	Operation	Flag						
					S	Z	AC	P/V	CY		
Bit manipulation	MOV1	CY, saddr.bit	3	$CY \leftarrow (\text{saddr.bit})$						x	
		CY, sfr.bit	3	$CY \leftarrow \text{sfr.bit}$						x	
		CY, A.bit	2	$CY \leftarrow \text{A.bit}$						x	
		CY, X.bit	2	$CY \leftarrow \text{X.bit}$						x	
		CY, PSWH.bit	2	$CY \leftarrow \text{PSWH.bit}$						x	
		CY, PSWL.bit	2	$CY \leftarrow \text{PSWL.bit}$						x	
		saddr.bit, CY	3	$(\text{saddr.bit}) \leftarrow CY$							
		sfr.bit, CY	3	$\text{sfr.bit} \leftarrow CY$							
		A.bit, CY	2	$\text{A.bit} \leftarrow CY$							
		X.bit, CY	2	$\text{X.bit} \leftarrow CY$							
		PSWH.bit, CY	2	$\text{PSWH.bit} \leftarrow CY$							
		PSWL.bit, CY	2	$\text{PSWL.bit} \leftarrow CY$			x	x	x	x	
	AND1	CY, saddr.bit	3	$CY \leftarrow CY \wedge (\text{saddr.bit})$						x	
		CY, /saddr.bit	3	$CY \leftarrow CY \wedge \overline{(\text{saddr.bit})}$						x	
		CY, sfr.bit	3	$CY \leftarrow CY \wedge \text{sfr.bit}$						x	
		CY, /sfr.bit	3	$CY \leftarrow CY \wedge \overline{\text{sfr.bit}}$						x	
		CY, A.bit	2	$CY \leftarrow CY \wedge \text{A.bit}$						x	
		CY, /A.bit	2	$CY \leftarrow CY \wedge \overline{\text{A.bit}}$						x	
		CY, X.bit	2	$CY \leftarrow CY \wedge \text{X.bit}$						x	
		CY, /X.bit	2	$CY \leftarrow CY \wedge \overline{\text{X.bit}}$						x	
		CY, PSWH.bit	2	$CY \leftarrow CY \wedge \text{PSWH.bit}$						x	
		CY, /PSWH.bit	2	$CY \leftarrow CY \wedge \overline{\text{PSWH.bit}}$						x	
		CY, PSWL.bit	2	$CY \leftarrow CY \wedge \text{PSWL.bit}$						x	
		CY, /PSWL.bit	2	$CY \leftarrow CY \wedge \overline{\text{PSWL.bit}}$						x	
	OR1	CY, saddr.bit	3	$CY \leftarrow CY \vee (\text{saddr.bit})$						x	
		CY, /saddr.bit	3	$CY \leftarrow CY \vee \overline{(\text{saddr.bit})}$						x	
		CY, sfr.bit	3	$CY \leftarrow CY \vee \text{sfr.bit}$						x	
		CY, /sfr.bit	3	$CY \leftarrow CY \vee \overline{\text{sfr.bit}}$						x	
		CY, A.bit	2	$CY \leftarrow CY \vee \text{A.bit}$						x	
		CY, /A.bit	2	$CY \leftarrow CY \vee \overline{\text{A.bit}}$						x	
		CY, X.bit	2	$CY \leftarrow CY \vee \text{X.bit}$						x	
		CY, /X.bit	2	$CY \leftarrow CY \vee \overline{\text{X.bit}}$						x	
		CY, PSWH.bit	2	$CY \leftarrow CY \vee \text{PSWH.bit}$						x	
		CY, /PSWH.bit	2	$CY \leftarrow CY \vee \overline{\text{PSWH.bit}}$						x	
		CY, PSWL.bit	2	$CY \leftarrow CY \vee \text{PSWL.bit}$						x	
		CY, /PSWL.bit	2	$CY \leftarrow CY \vee \overline{\text{PSWL.bit}}$						x	



Instructions	Mnemonic	Operand	Byte	Operation	Flag					
					S	Z	AC	P/V	CY	
Bit manipulation	<b>XOR1</b>	CY, saddr.bit	3	$CY \leftarrow CY \oplus (\text{saddr.bit})$						x
		CY, sfr.bit	3	$CY \leftarrow CY \oplus \text{sfr.bit}$						x
		CY, A.bit	2	$CY \leftarrow CY \oplus A.\text{bit}$						x
		CY, X.bit	2	$CY \leftarrow CY \oplus X.\text{bit}$						x
		CY, PSWH.bit	2	$CY \leftarrow CY \oplus \text{PSWH.bit}$						x
		CY, PSWL.bit	2	$CY \leftarrow CY \oplus \text{PSWL.bit}$						x
	<b>SET1</b>	saddr.bit	2	$(\text{saddr.bit}) \leftarrow 1$						
		sfr.bit	3	$\text{sfr.bit} \leftarrow 1$						
		A.bit	2	$A.\text{bit} \leftarrow 1$						
		X.bit	2	$X.\text{bit} \leftarrow 1$						
		PSWH.bit	2	$\text{PSWH.bit} \leftarrow 1$						
		PSWL.bit	2	$\text{PSWL.bit} \leftarrow 1$		x	x	x	x	x
	<b>CLR1</b>	saddr.bit	2	$(\text{saddr.bit}) \leftarrow 0$						
		sfr.bit	3	$\text{sfr.bit} \leftarrow 0$						
		A.bit	2	$A.\text{bit} \leftarrow 0$						
		X.bit	2	$X.\text{bit} \leftarrow 0$						
		PSWH.bit	2	$\text{PSWH.bit} \leftarrow 0$						
		PSWL.bit	2	$\text{PSWL.bit} \leftarrow 0$		x	x	x	x	x
	<b>NOT1</b>	saddr.bit	3	$(\text{saddr.bit}) \leftarrow \overline{(\text{saddr.bit})}$						
		sfr.bit	3	$\text{sfr.bit} \leftarrow \overline{\text{sfr.bit}}$						
		A.bit	2	$A.\text{bit} \leftarrow \overline{A.\text{bit}}$						
		X.bit	2	$X.\text{bit} \leftarrow \overline{X.\text{bit}}$						
		PSWH.bit	2	$\text{PSWH.bit} \leftarrow \overline{\text{PSWH.bit}}$						
		PSWL.bit	2	$\text{PSWL.bit} \leftarrow \overline{\text{PSWL.bit}}$		x	x	x	x	x
	<b>SET1</b>	CY	1	$CY \leftarrow 1$						1
	<b>CLR1</b>	CY	1	$CY \leftarrow 0$						0
	<b>NOT1</b>	CY	1	$CY \leftarrow \overline{CY}$						x

Instructions	Mnemonic	Operand	Byte	Operation	Flag				
					S	Z	AC	P/V	CY
Call/return	<b>CALL</b>	!addr16	3	$(SP - 1) \leftarrow (PC + 3)_H, (SP - 2) \leftarrow (PC + 3)_L,$ $PC \leftarrow \text{addr16}, SP \leftarrow SP - 2$					
	<b>CALLF</b>	!addr11	2	$(SP - 1) \leftarrow (PC + 2)_H, (SP - 2) \leftarrow (PC + 2)_L,$ $PC_{15-11} \leftarrow 00001, PC_{10-0} \leftarrow \text{addr11}, SP \leftarrow SP - 2$					
	<b>CALLT</b>	[addr5]	1	$(SP - 1) \leftarrow (PC + 1)_H, (SP - 2) \leftarrow (PC + 1)_L,$ $PC_H \leftarrow (TPF, 00000000, \text{addr5} + 1),$ $PC_L \leftarrow (TPF, 00000000, \text{addr5}), SP \leftarrow SP - 2$					
	<b>CALL</b>	rp1	2	$(SP - 1) \leftarrow (PC + 2)_H, (SP - 2) \leftarrow (PC + 2)_L,$ $PC_H \leftarrow rp1_H, PC_L \leftarrow rp1_L, SP \leftarrow SP - 2$					
		[rp1]	2	$(SP - 1) \leftarrow (PC + 2)_H, (SP - 2) \leftarrow (PC + 2)_L,$ $PC_H \leftarrow (rp1 + 1), PC_L \leftarrow (rp1), SP \leftarrow SP - 2$					
	<b>BRK</b>		1	$(SP - 1) \leftarrow PSW_H, (SP - 2) \leftarrow PSW_L$ $(SP - 3) \leftarrow (PC + 1)_H, (SP - 4) \leftarrow (PC + 1)_L,$ $PC_L \leftarrow (003EH), PC_H \leftarrow (003FH),$ $SP \leftarrow SP - 4, IE \leftarrow 0$					
	<b>RET</b>		1	$PC_L \leftarrow (SP), PC_H \leftarrow (SP + 1), SP \leftarrow SP + 2$					
	<b>RETB</b>		1	$PC_L \leftarrow (SP), PC_H \leftarrow (SP + 1)$ $PSW_L \leftarrow (SP + 2), PSW_H \leftarrow (SP + 3)$ $SP \leftarrow SP + 4$	R	R	R	R	R
<b>RETI</b>		1	$PC_L \leftarrow (SP), PC_H \leftarrow (SP + 1)$ $PSW_L \leftarrow (SP + 2), PSW_H \leftarrow (SP + 3)$ $SP \leftarrow SP + 4$	R	R	R	R	R	
Stack manipulation	<b>PUSH</b>	sfrp	3	$(SP - 1) \leftarrow sfr_H$ $(SP - 2) \leftarrow sfr_L$ $SP \leftarrow SP - 2$					
		post	2	$\{(SP - 1) \leftarrow \text{post}_H, (SP - 2) \leftarrow \text{post}_L, SP \leftarrow SP - 2\} \times n \text{ times}$					
		PSW	1	$(SP - 1) \leftarrow PSW_H, (SP - 2) \leftarrow PSW_L, SP \leftarrow SP - 2$					
	<b>PUSHU</b>	post	2	$\{(UP - 1) \leftarrow \text{post}_H, (UP - 2) \leftarrow \text{post}_L, UP \leftarrow UP - 2\} \times n \text{ times}$					
	<b>POP</b>	sfrp	3	$sfr_L \leftarrow (SP)$ $sfr_H \leftarrow (SP + 1)$ $SP \leftarrow SP + 2$					
		post	2	$\{\text{post}_L \leftarrow (SP), \text{post}_H \leftarrow (SP + 1), SP \leftarrow SP + 2\} \times n \text{ times}$					
		PSW	1	$PSW_L \leftarrow (SP), PSW_H \leftarrow (SP + 1), SP \leftarrow SP + 2$	R	R	R	R	R
	<b>POPU</b>	post	2	$\{\text{post}_L \leftarrow (UP), \text{post}_H \leftarrow (UP + 1), UP \leftarrow UP + 2\} \times n \text{ times}$					
	<b>MOVW</b>	SP, #word	4	$SP \leftarrow \text{word}$					
		SP, AX	2	$SP \leftarrow AX$					
		AX, SP	2	$AX \leftarrow SP$					
<b>INCW</b>	SP	2	$SP \leftarrow SP + 1$						
<b>DECW</b>	SP	2	$SP \leftarrow SP - 1$						

**Remark** n of the stack manipulation instruction is the number of registers written as post.

Instructions	Mnemonic	Operand	Byte	Operation	Flag				
					S	Z	AC	P/V	CY
Special	<b>CHKL</b>	sfr	3	(pin level) ⇄ (signal level before output buffer)	×	×		P	
	<b>CHKLA</b>	sfr	3	A ← (pin level) ⇄ (signal level before output buffer)	×	×		P	
Unconditional branch	<b>BR</b>	!addr16	3	PC ← addr16					
		rp1	2	PC <sub>H</sub> ← rp1 <sub>H</sub> , PC <sub>L</sub> ← rp1 <sub>L</sub>					
		[rp1]	2	PC <sub>H</sub> ← (rp1 + 1), PC <sub>L</sub> ← (rp1)					
		\$addr16	2	PC ← PC + 2 + jdisp8					
Conditional branch	<b>BC</b>	\$addr16	2	PC ← PC + 2 + jdisp8 if CY = 1					
	<b>BL</b>								
	<b>BNC</b>	\$addr16	2	PC ← PC + 2 + jdisp8 if CY = 0					
	<b>BNL</b>								
	<b>BZ</b>	\$addr16	2	PC ← PC + 2 + jdisp8 if Z = 1					
	<b>BE</b>								
	<b>BNZ</b>	\$addr16	2	PC ← PC + 2 + jdisp8 if Z = 0					
	<b>BNE</b>								
	<b>BV</b>	\$addr16	2	PC ← PC + 2 + jdisp8 if P/V = 1					
	<b>BPE</b>								
	<b>BNV</b>	\$addr16	2	PC ← PC + 2 + jdisp8 if P/V = 0					
	<b>BPO</b>								
	<b>BN</b>	\$addr16	2	PC ← PC + 2 + jdisp8 if S = 1					
	<b>BP</b>	\$addr16	2	PC ← PC + 2 + jdisp8 if S = 0					
	<b>BGT</b>	\$addr16	3	PC ← PC + 3 + jdisp8 if (P/V ⇄ S) / Z = 0					
	<b>BGE</b>	\$addr16	3	PC ← PC + 3 + jdisp8 if P/V ⇄ S = 0					
	<b>BLT</b>	\$addr16	3	PC ← PC + 3 + jdisp8 if P/V ⇄ S = 1					
	<b>BLE</b>	\$addr16	3	PC ← PC + 3 + jdisp8 if (P/V ⇄ S) / Z = 1					
	<b>BH</b>	\$addr16	3	PC ← PC + 3 + jdisp8 if Z ∨ CY = 0					
	<b>BNH</b>	\$addr16	3	PC ← PC + 3 + jdisp8 if Z ∨ CY = 1					
	<b>BT</b>	saddr.bit, \$addr16	3	PC ← PC + 3 + jdisp8 if (saddr.bit) = 1					
		sfr.bit, \$addr16	4	PC ← PC + 4 + jdisp8 if sfr.bit = 1					
		A.bit, \$addr16	3	PC ← PC + 3 + jdisp8 if A.bit = 1					
		X.bit, \$addr16	3	PC ← PC + 3 + jdisp8 if X.bit = 1					
PSWH.bit, \$addr16		3	PC ← PC + 3 + jdisp8 if PSWH.bit = 1						
PSWL.bit, \$addr16		3	PC ← PC + 3 + jdisp8 if PSWL.bit = 1						
<b>BF</b>	saddr.bit, \$addr16	4	PC ← PC + 4 + jdisp8 if (saddr.bit) = 0						
	sfr.bit, \$addr16	4	PC ← PC + 4 + jdisp8 if sfr.bit = 0						
	A.bit, \$addr16	3	PC ← PC + 3 + jdisp8 if A.bit = 0						
	X.bit, \$addr16	3	PC ← PC + 3 + jdisp8 if X.bit = 0						
	PSWH.bit, \$addr16	3	PC ← PC + 3 + jdisp8 if PSWH.bit = 0						
	PSWL.bit, \$addr16	3	PC ← PC + 3 + jdisp8 if PSWL.bit = 0						

Instructions	Mnemonic	Operand	Byte	Operation	Flag				
					S	Z	AC	P/V	CY
Conditional branch	<b>BTCLR</b>	saddr.bit, \$addr16	4	PC ← PC + 4 + jdisp8 if (saddr.bit) = 1 then reset (saddr.bit)					
		sfr.bit, \$addr16	4	PC ← PC + 4 + jdisp8 if sfr.bit = 1 then reset sfr.bit					
		A.bit, \$addr16	3	PC ← PC + 3 + jdisp8 if A.bit = 1 then reset A.bit					
		X.bit, \$addr16	3	PC ← PC + 3 + jdisp8 if X.bit = 1 then reset X.bit					
		PSWH.bit, \$addr16	3	PC ← PC + 3 + jdisp8 if PSWH.bit = 1 then reset PSWH.bit					
		PSWL.bit, \$addr16	3	PC ← PC + 3 + jdisp8 if PSWL.bit = 1 then reset PSWL.bit	×	×	×	×	×
	<b>BFSET</b>	saddr.bit, \$addr16	4	PC ← PC + 4 + jdisp8 if (saddr.bit) = 0 then set (saddr.bit)					
		sfr.bit, \$addr16	4	PC ← PC + 4 + jdisp8 if sfr.bit = 0 then set sfr.bit					
		A.bit, \$addr16	3	PC ← PC + 3 + jdisp8 if A.bit = 0 then set A.bit					
		X.bit, \$addr16	3	PC ← PC + 3 + jdisp8 if X.bit = 0 then set X.bit					
		PSWH.bit, \$addr16	3	PC ← PC + 3 + jdisp8 if PSWH.bit = 0 then set PSWH.bit					
		PSWL.bit, \$addr16	3	PC ← PC + 3 + jdisp8 if PSWL.bit = 0 then set PSWL.bit	×	×	×	×	×
<b>DBNZ</b>	r2, \$addr16	2	r2 ← r2 - 1, then PC ← PC + 2 + jdisp8 if 2 ≠ 0						
	saddr, \$addr16	3	(saddr) ← (saddr) - 1, then PC ← PC + 3 + jdisp8 if (saddr) ≠ 0						
Context switching	<b>BRKCS</b>	RBn	2	PC <sub>H</sub> ↔ R5, PC <sub>L</sub> ↔ R4, R7 ← PSW <sub>H</sub> , R6 ← PSW <sub>L</sub> , ← RBS2 - 0 ← n, RSS ← 0, IE ← 0					
	<b>RETCS</b>	!addr16	3	PC <sub>H</sub> ← R5, PC <sub>L</sub> ← R4, R5, R4 ← addr16 PSW <sub>H</sub> ← R7, PSW <sub>L</sub> ← R6	R	R	R	R	R
	<b>RETCSB</b>	!addr16	4	PC <sub>H</sub> ← R5, PC <sub>L</sub> ← R4, R5, R4 ← addr16 PSW <sub>H</sub> ← R7, PSW <sub>L</sub> ← R6	R	R	R	R	R

Instructions	Mnemonic	Operand	Byte	Operation	Flag				
					S	Z	AC	P/V	CY
String	<b>MOVM</b>	[DE+], A	2	(DE+) ← A, C ← C - 1 End if C = 0					
		[DE-], A	2	(DE-) ← A, C ← C - 1 End if C = 0					
	<b>MOVBK</b>	[DE+], [HL+]	2	(DE+) ← (HL+), C ← C - 1 End if C = 0					
		[DE-], [HL-]	2	(DE-) ← (HL-), C ← C - 1 End if C = 0					
	<b>XCHM</b>	[DE+], A	2	(DE+) ↔ A, C ← C - 1 End if C = 0					
		[DE-], A	2	(DE-) ↔ A, C ← C - 1 End if C = 0					
	<b>XCHBK</b>	[DE+], [HL+]	2	(DE+) ↔ (HL+), C ← C - 1 End if C = 0					
		[DE-], [HL-]	2	(DE-) ↔ (HL-), C ← C - 1 End if C = 0					
	<b>CMPME</b>	[DE+], A	2	(DE+) - A, C ← C - 1 End if C = 0 or Z = 0	×	×	×	V	×
		[DE-], A	2	(DE-) - A, C ← C - 1 End if C = 0 or Z = 0	×	×	×	V	×
	<b>CMPBKE</b>	[DE+], [HL+]	2	(DE+) - (HL+), C ← C - 1 End if C = 0 or Z = 0	×	×	×	V	×
		[DE-], [HL-]	2	(DE-) - (HL-), C ← C - 1 End if C = 0 or Z = 0	×	×	×	V	×
	<b>CMPMNE</b>	[DE+], A	2	(DE+) - A, C ← C - 1 End if C = 0 or Z = 1	×	×	×	V	×
		[DE-], A	2	(DE-) - A, C ← C - 1 End if C = 0 or Z = 1	×	×	×	V	×
	<b>CMPBKNE</b>	[DE+], [HL+]	2	(DE+) - (HL+), C ← C - 1 End if C = 0 or Z = 1	×	×	×	V	×
		[DE-], [HL-]	2	(DE-) - (HL-), C ← C - 1 End if C = 0 or Z = 1	×	×	×	V	×
	<b>CMPMC</b>	[DE+], A	2	(DE+) - A, C ← C - 1 End if C = 0 or CY = 0	×	×	×	V	×
		[DE-], A	2	(DE-) - A, C ← C - 1 End if C = 0 or CY = 0	×	×	×	V	×
	<b>CMPBKC</b>	[DE+], [HL+]	2	(DE+) - (HL+), C ← C - 1 End if C = 0 or CY = 0	×	×	×	V	×
		[DE-], [HL-]	2	(DE-) - (HL-), C ← C - 1 End if C = 0 or CY = 0	×	×	×	V	×

Instructions	Mnemonic	Operand	Byte	Operation	Flag				
					S	Z	AC	P/V	CY
String	CMPMNC	[DE+], A	2	(DE+) - A, C ← C - 1 End if C = 0 or CY = 1	×	×	×	V	×
		[DE-], A	2	(DE-) - A, C ← C - 1 End if C = 0 or CY = 1	×	×	×	V	×
	CMPBKNC	[DE+], [HL+]	2	(DE+) - (HL+), C ← C - 1 End if C = 0 or CY = 1	×	×	×	V	×
		[DE-], [HL-]	2	(DE-) - (HL-), C ← C - 1 End if C = 0 or CY = 1	×	×	×	V	×
CPU control	MOV	STBC, #byte	4	STBC ← byte <sup>Note</sup>					
		WDM, #byte	4	WDM ← byte <sup>Note</sup>					
	SWRS		1	RSS ← $\overline{\text{RSS}}$					
	SEL	RBn	2	RBS2 - 0 ← n, RSS ← 0					
		RBn, ALT	2	RBS2 - 0 ← n, RSS ← 1					
	NOP		1	No Operation					
	EI		1	IE ← 1 (Enable Interrupt)					
DI		1	IE ← 0 (Disable Interrupt)						

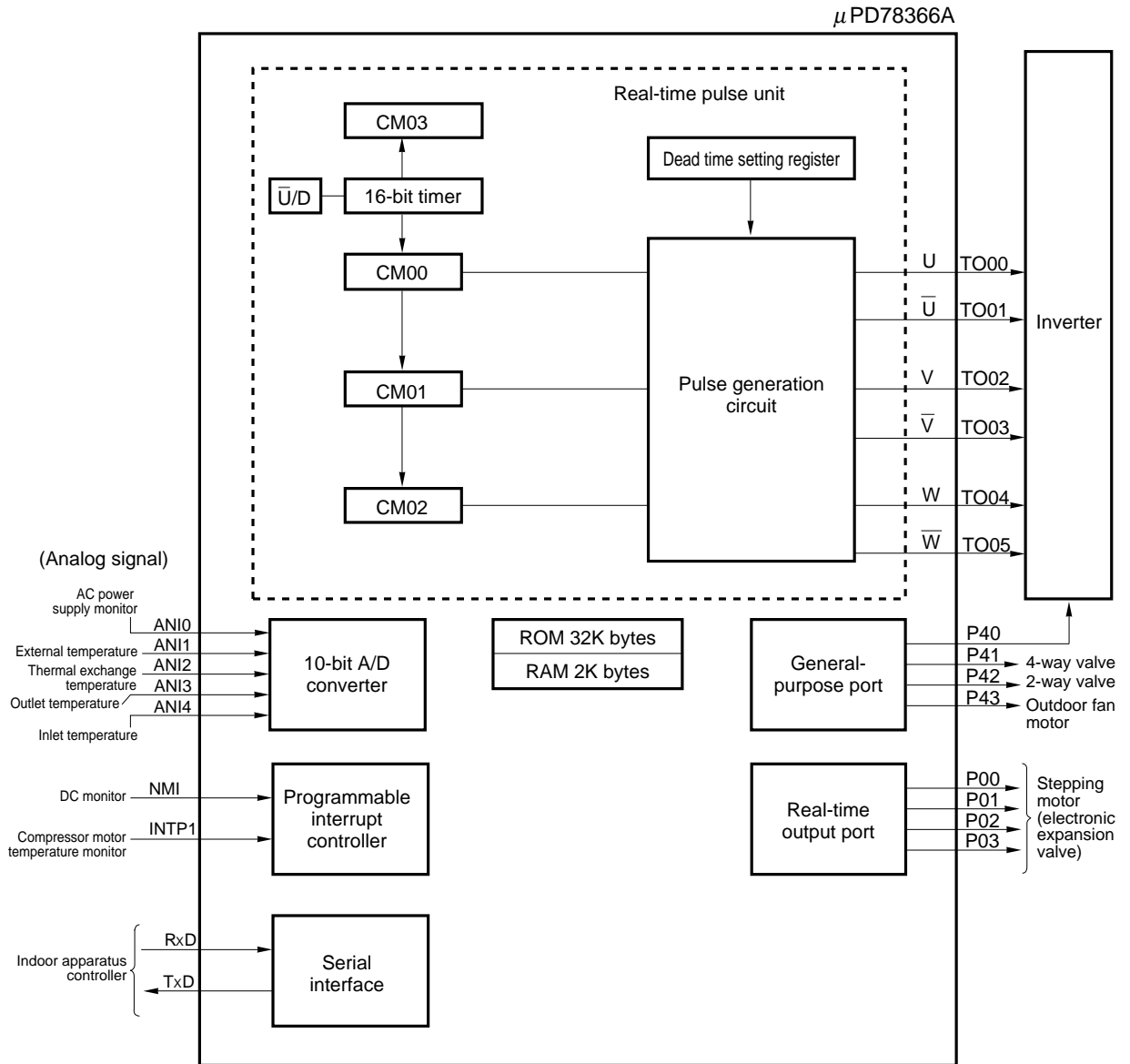
**Note** If the op code of the STBC register and WDM register manipulation instructions is wrong, an op code trap interrupt occurs.

Operation on trap:

$(SP - 1) \leftarrow PSW_H, (SP - 2) \leftarrow PSW_L,$   
 $(SP - 3) \leftarrow (PC - 4)_H, (SP - 4) \leftarrow (PC - 4)_L,$   
 $PC_L \leftarrow (003CH), PC_H \leftarrow (003DH),$   
 $SP \leftarrow SP - 4, IE \leftarrow 0$

9. EXAMPLE OF SYSTEM CONFIGURATION

Controlling outdoor apparatus of inverter air conditioner



10. ELECTRICAL SPECIFICATIONS

Absolute Maximum Ratings (T<sub>A</sub> = 25 °C)

Parameter	Symbol	Test conditions	Rating	Unit
Power supply voltage	V <sub>DD</sub>		-0.5 to +7.0	V
	AV <sub>DD</sub>		-0.5 to V <sub>DD</sub> + 0.5	V
	AV <sub>SS</sub>		-0.5 to +0.5	V
Input voltage	V <sub>I</sub>	Pins other than P70/ANI0-P77/ANI7	-0.5 to V <sub>DD</sub> + 0.5	V
Output voltage	V <sub>O</sub>		-0.5 to V <sub>DD</sub> + 0.5	V
Low-level output current	I <sub>OL</sub>	<b>Note</b>	20	mA
		Output pins other than those in the note	4.0	mA
		Total of all output pins	200	mA
High-level output current	I <sub>OH</sub>	All output pins	-3.0	mA
		Total of all output pins	-25	mA
Analog input voltage	V <sub>IAN</sub>	P70/ANI0-P77/ANI7 pins	AV <sub>SS</sub> - 0.5 to AV <sub>DD</sub> + 0.5	V
A/D converter reference input voltage	AV <sub>REF</sub>		AV <sub>SS</sub> - 0.5 to AV <sub>DD</sub> + 0.5	V
Operating ambient temperature	T <sub>A</sub>		-40 to +85	°C
Storage temperature	T <sub>stg</sub>		-60 to +150	°C

**Note** P00/RTP0-P03/RTP3, P04/PWM0, P05/TCUD/PWM1, P06/TIUD/TO40, P07/TCLRUD, P10-P17, and P80/TO00-P85/TO05 pins.

**Caution** Product quality may suffer if the absolute rating is exceeded for any parameter, even momentarily. In other words, an absolute maximum rating is a value at which the possibility of physical damage to the product cannot be ruled out. Care must therefore be taken to ensure that these ratings are not exceeded during use of the product.

Recommended Operating Conditions

Oscillation frequency	T <sub>A</sub>	V <sub>DD</sub>
3 MHz ≤ f <sub>xx</sub> ≤ 8 MHz	-40 to +85 °C	+5.0 V ± 10 %

Capacitance (T<sub>A</sub> = 25 °C, V<sub>SS</sub> = V<sub>DD</sub> = 0 V)

Parameter	Symbol	Test conditions	MIN.	TYP.	MAX.	Unit
Input capacitance	C <sub>I</sub>	f = 1 MHz 0 V except measured pins			20	pF
Output capacitance	C <sub>O</sub>				20	pF
I/O capacitance	C <sub>IO</sub>				20	pF



**Oscillator Characteristics (T<sub>A</sub> = -40 to +85 °C, V<sub>DD</sub> = +5 V ± 10 %, V<sub>SS</sub> = 0 V)**

Resonator	Recommended circuit	Parameter	MIN.	MAX.	Unit
Ceramic resonator or crystal resonator		Oscillation frequency (f <sub>xx</sub> )	3	8	MHz
External clock		X1 input frequency (f <sub>x</sub> )	3	8	MHz
		X1 rise/fall time (t <sub>xR</sub> , t <sub>xF</sub> )	0	30	ns
		X1 input high-/low-level width (t <sub>wXH</sub> , t <sub>wXL</sub> )	40	170	ns

**Caution** When using system clock oscillation circuits, to reduce the effect of the wiring capacitance, etc, wire the area indicated by dotted-line as follows:

- Make the wiring as short as possible.
- Do not allow the wiring to intersect other signal lines. Keep it away from other lines in which varying high currents flow.
- Make sure that the ground point of the oscillation circuit capacitor is always at the same electric potential as V<sub>SS</sub>. Do not allow the wiring to be grounded to a ground pattern in which very high currents are flowing.
- Do not extract signals from the oscillation circuit.

DC Characteristics (T<sub>A</sub> = -40 to +85 °C, V<sub>DD</sub> = +5 V ± 10 %, V<sub>SS</sub> = 0 V)

Parameter	Symbol	Test conditions	MIN.	TYP.	MAX.	Unit
Low-level input voltage	V <sub>IL1</sub>	<b>Note 1</b>	0		0.8	V
	V <sub>IL2</sub>	<b>Note 2</b>	0		0.2V <sub>DD</sub>	V
High-level input voltage	V <sub>IH1</sub>	<b>Note 1</b>	2.2			V
	V <sub>IH2</sub>	<b>Note 2</b>	0.8V <sub>DD</sub>			V
Low-level output voltage	V <sub>OL1</sub>	<b>Note 3</b>	I <sub>OL</sub> = 2.0 mA		0.45	V
	V <sub>OL2</sub>	<b>Note 4</b>	I <sub>OL</sub> = 15 mA		1.5	V
	V <sub>OL3</sub>	<b>Note 5</b>	I <sub>OL</sub> = 10 mA		1.5	V
High-level output voltage	V <sub>OH</sub>	I <sub>OH</sub> = -400 μA	V <sub>DD</sub> - 1.0			V
Input leakage current	I <sub>LI</sub>	0 V ≤ V <sub>I</sub> ≤ V <sub>DD</sub> , AV <sub>DD</sub> = V <sub>DD</sub>			±10	μA
Output leakage current	I <sub>LO</sub>	0 V ≤ V <sub>O</sub> ≤ V <sub>DD</sub> , AV <sub>DD</sub> = V <sub>DD</sub>			±10	μA
V <sub>DD</sub> supply current	I <sub>DD1</sub>	Operating mode		70	120	mA
	I <sub>DD2</sub>	HALT mode		45	70	mA
Data retention voltage	V <sub>DDDR</sub>	STOP mode	2.5			V
Data retention current	I <sub>DDDR</sub>	STOP mode	V <sub>DDDR</sub> = 2.5 V	2	10	μA
			V <sub>DDDR</sub> = 5.0 V ± 10 %	10	50	μA
Pull-up resistance	R <sub>L</sub>	V <sub>I</sub> = 0 V	15	60	150	kΩ

**Notes 1.** Pins other than those specified in **Note 2**.

2.  $\overline{\text{RESET}}$ , X1, X2, P20/NMI, P21/INTP0, P22/INTP1, P23/INTP2, P24/INTP3/TI, P25/INTP4, P32/SO/SB0, P33/SI/SB1 and P34/ $\overline{\text{SCK}}$  pins.
3. Pins other than those specified in Notes 4 and 5.
4. P80/TO00-P85/TO05 pins (When I<sub>OL</sub> = 15 mA is in operation, up to three pins can be ON simultaneously.)
5. P00/RTP0-P03/RTP3, P04/PWM0, P05/TCUD/PWM1, P06/TIUD/TO40 and P07/TCLRUD pins (When I<sub>OL</sub> = 10 mA is in operation, up to four pins can be ON simultaneously.) as well as P10-P17 pins (When I<sub>OL</sub> = 10 mA is in operation, up to four pins can be ON simultaneously.).

**Caution** When the P80-P85, P00-P07, and P10-P17 pins are not used under the conditions specified in Notes 4 and 5, they have the same characteristics as in Note 3.

AC Characteristics (T<sub>A</sub> = -40 to +85 °C, V<sub>DD</sub> = +5 V ± 10 %, V<sub>SS</sub> = 0 V, C<sub>L</sub> = 100 pF, f<sub>XX</sub> = 8 MHz)

Read/Write Operation (when general-purpose memory is connected)

Parameter	Symbol	Test conditions	MIN.	MAX.	Unit
System clock cycle time	t <sub>CYK</sub>		62.5	166.7	ns
Address setup time (vs. ASTB ↓)	t <sub>SAST</sub>		7		ns
Address hold time (vs. ASTB ↓)	t <sub>HSTA</sub>		11		ns
$\overline{RD}$ ↓ → address float time	t <sub>FRA</sub>			24	ns
Address → data input time	t <sub>DAID</sub>			100	ns
$\overline{RD}$ ↓ → data input time	t <sub>DRID</sub>			49	ns
ASTB ↓ → $\overline{RD}$ ↓ delay time	t <sub>DSTR</sub>		15		ns
Data hold time (vs. $\overline{RD}$ ↑)	t <sub>HRID</sub>		0		ns
$\overline{RD}$ ↑ → address active time	t <sub>DRA</sub>		17		ns
$\overline{RD}$ low-level width	t <sub>WRL</sub>		63		ns
ASTB high-level width	t <sub>WSTH</sub>		14		ns
$\overline{WR}$ ↓ → data output time	t <sub>DWOD</sub>			21	ns
ASTB ↓ → $\overline{WR}$ ↓ delay time	t <sub>DSTW</sub>		15		ns
$\overline{WR}$ ↑ → ASTB ↑ delay time	t <sub>DWST</sub>		78		ns
Data setup time (vs. $\overline{WR}$ ↑)	t <sub>SODW</sub>		57		ns
Data hold time (vs. $\overline{WR}$ ↑)	t <sub>HWOD</sub>		8		ns
$\overline{WR}$ low-level width	t <sub>WWL</sub>		63		ns

t<sub>CYK</sub>-dependent Bus Timing Definition

Parameter	Arithmetic expression	MIN./MAX.	Unit
t <sub>SAST</sub>	(0.5 + a) T - 24	MIN.	ns
t <sub>HSTA</sub>	0.5T - 20	MIN.	ns
t <sub>WSTH</sub>	(0.5 + a) T - 17	MIN.	ns
t <sub>DSTR</sub>	0.5T - 16	MIN.	ns
t <sub>WRL</sub>	(1.5 + n) T - 30	MIN.	ns
t <sub>DAID</sub>	(2.5 + a + n) T - 56	MAX.	ns
t <sub>DRID</sub>	(1.5 + n) T - 44	MAX.	ns
t <sub>DRA</sub>	0.5T - 14	MIN.	ns
t <sub>DSTW</sub>	0.5T - 16	MIN.	ns
t <sub>DWST</sub>	1.5T - 15	MIN.	ns
t <sub>WWL</sub>	(1.5 + n) T - 30	MIN.	ns
t <sub>DWOD</sub>	0.5T - 10	MAX.	ns
t <sub>SODW</sub>	(1 + n) T - 5	MIN.	ns

Remarks 1. T = t<sub>CYK</sub> = 1/f<sub>CLK</sub> (f<sub>CLK</sub> refers to the internal system clock frequency.)

2. a becomes 1 when the address wait is inserted. Otherwise, it becomes 0.
3. n refers to the number of wait cycles that is inserted by specifying the PWC register.
4. Only the bus timings indicated in this table depend on t<sub>CYK</sub>.

**Serial Operation (T<sub>A</sub> = -40 to +85 °C, V<sub>DD</sub> = +5 V ± 10 %, V<sub>SS</sub> = 0 V)**

Parameter	Symbol	Test conditions		MIN.	MAX.	Unit
Serial clock cycle time	t <sub>CYSK</sub>	$\overline{\text{SCK}}$ output	Internal 8 dividing	500		ns
		$\overline{\text{SCK}}$ input	External clock	500		ns
Serial clock low-level width	t <sub>WSKL</sub>	$\overline{\text{SCK}}$ output	Internal 8 dividing	210		ns
		$\overline{\text{SCK}}$ input	External clock	210		ns
Serial clock high-level width	t <sub>WSKH</sub>	$\overline{\text{SCK}}$ output	Internal 8 dividing	210		ns
		$\overline{\text{SCK}}$ input	External clock	210		ns
SI setup time (vs. $\overline{\text{SCK}}$ ↑)	t <sub>SRXSK</sub>			80		ns
SI hold time (vs. $\overline{\text{SCK}}$ ↑)	t <sub>HSKRX</sub>			80		ns
$\overline{\text{SCK}}$ ↓ → SO delay time	t <sub>DSKTX</sub>	R = 1 kΩ, C = 100 pF			210	ns

**Up/Down Counter Operation (T<sub>A</sub> = -40 to +85 °C, V<sub>DD</sub> = +5 V ± 10 %, V<sub>SS</sub> = 0 V)**

Parameter	Symbol	Test conditions	MIN.	MAX.	Unit
TIUD high-/low-level width	t <sub>WTIUH</sub> , t <sub>WTIUL</sub>	Other than mode 4	2T		ns
		Mode 4	4T		ns
TCUD high-/low-level width	t <sub>WTCUH</sub> , t <sub>WTCUL</sub>	Other than mode 4	2T		ns
		Mode 4	4T		ns
TCLRUD high-/low-level width	t <sub>WCLUH</sub> , t <sub>WCLUL</sub>		2T		ns
TCUD setup time (vs. TIUD ↑)	t <sub>STCU</sub>	Mode 3	T		ns
TCUD hold time (vs. TIUD ↑)	t <sub>HTCU</sub>	Mode 3	T		ns
TIUD setup time (vs. TCUD)	t <sub>S4TIU</sub>	Mode 4	2T		ns
TIUD hold time (vs. TCUD)	t <sub>H4TIU</sub>	Mode 4	2T		ns
TIUD & TCUD cycle time	t <sub>CYC</sub>	Other than mode 4		4	MHz
	t <sub>CYC4</sub>	Mode 4		2	MHz

**Remark** T = t<sub>CYK</sub> = 1/f<sub>CLK</sub> (f<sub>CLK</sub> refers to the internal system clock frequency.)

Other Operations (T<sub>A</sub> = -40 to +85 °C, V<sub>DD</sub> = +5 V ± 10 %, V<sub>SS</sub> = 0 V)

Parameter	Symbol	Test conditions	MIN.	MAX.	Unit
NMI high-/low-level width	t <sub>WN1H</sub> , t <sub>WN1L</sub>		2		μs
RESET high-/low-level width	t <sub>WRSH</sub> , t <sub>WRSL</sub>		1.5		μs
INTP0 high-/low-level width	t <sub>WI0H</sub> , t <sub>WI0L</sub>	T <sub>s</sub> = T	250		ns
		T <sub>s</sub> = 4T	1.0		μs
		T <sub>s</sub> = 8T	2.0		μs
		T <sub>s</sub> = 16T	4.0		μs
INTP1 high-/low-level width	t <sub>WI1H</sub> , t <sub>WI1L</sub>	T <sub>s</sub> = T	250		ns
		T <sub>s</sub> = 4T	1.0		μs
		T <sub>s</sub> = 8T	2.0		μs
		T <sub>s</sub> = 16T	4.0		μs
INTP2 high-/low-level width	t <sub>WI2H</sub> , t <sub>WI2L</sub>	T <sub>s</sub> = T	250		ns
		T <sub>s</sub> = 4T	1.0		μs
INTP3(TI) high-/low-level width	t <sub>WI3H</sub> , t <sub>WI3L</sub>	T <sub>s</sub> = T	250		ns
		T <sub>s</sub> = 4T	1.0		μs
		T <sub>s</sub> = 8T	2.0		μs
		T <sub>s</sub> = 16T	4.0		μs
		T <sub>s</sub> = 64T	16.0		μs
		T <sub>s</sub> = 128T	32.0		μs
		T <sub>s</sub> = 256T	64.0		μs
INTP4 high-/low-level width	t <sub>WI4H</sub> , t <sub>WI4L</sub>	T <sub>s</sub> = T	250		ns
		T <sub>s</sub> = 4T	1.0		μs
		T <sub>s</sub> = 8T	2.0		μs
		T <sub>s</sub> = 16T	4.0		μs

**Remarks 1.** T = t<sub>CYK</sub> = 1/f<sub>CLK</sub> (f<sub>CLK</sub> refers to the internal system clock frequency.)

**2.** T<sub>s</sub> refers to the input sampling frequency. INTP0-INTP4 can be selected to programmable.

**A/D Converter Characteristics (T<sub>A</sub> = -40 to +85 °C, V<sub>DD</sub> = +5 V ± 10 %, V<sub>SS</sub> = AV<sub>SS</sub> = 0 V, V<sub>DD</sub> - 0.5 V ≤ AV<sub>DD</sub> ≤ V<sub>DD</sub>)**

Parameter	Symbol	Test conditions	MIN.	TYP.	MAX.	Unit	
Resolution			10			bit	
Total error <sup>Note 1</sup>		4.5 V ≤ AV <sub>REF</sub> ≤ AV <sub>DD</sub>			±0.4	%FSR	
		3.4 V ≤ AV <sub>REF</sub> ≤ AV <sub>DD</sub>			±0.7	%FSR	
Quantization error					±1/2	LSB	
★ Conversion time	t <sub>CONV</sub>	62.5 ns ≤ t <sub>CYK</sub> < 80 ns	208			t <sub>CYK</sub>	
		80 ns ≤ t <sub>CYK</sub> ≤ 166.6 ns	169			t <sub>CYK</sub>	
★ Sampling time	t <sub>SAMP</sub>	62.5 ns ≤ t <sub>CYK</sub> < 80 ns	24			t <sub>CYK</sub>	
		80 ns ≤ t <sub>CYK</sub> ≤ 166.6 ns	20			t <sub>CYK</sub>	
Zero-scale error <sup>Note 1</sup>		4.5 V ≤ AV <sub>REF</sub> ≤ AV <sub>DD</sub>		±1.5	±2.5	LSB	
		3.4 V ≤ AV <sub>REF</sub> ≤ AV <sub>DD</sub>		±1.5	±4.5	LSB	
Full-scale error <sup>Note 1</sup>		4.5 V ≤ AV <sub>REF</sub> ≤ AV <sub>DD</sub>		±1.5	±2.5	LSB	
		3.4 V ≤ AV <sub>REF</sub> ≤ AV <sub>DD</sub>		±1.5	±4.5	LSB	
Nonlinearity error <sup>Note 1</sup>		4.5 V ≤ AV <sub>REF</sub> ≤ AV <sub>DD</sub>		±1.5	±2.5	LSB	
		3.4 V ≤ AV <sub>REF</sub> ≤ AV <sub>DD</sub>		±1.5	±4.5	LSB	
Analog input voltage <sup>Note 2</sup>	V <sub>IAN</sub>		-0.3		AV <sub>REF</sub> + 0.3	V	
Analog input impedance	R <sub>AN</sub>	When not sampling		10		MΩ	
		When sampling		<b>Note 3</b>			
Reference voltage	AV <sub>REF</sub>		3.4		AV <sub>DD</sub>	V	
AV <sub>REF1</sub> current	AI <sub>REF</sub>			1.0	3.0	mA	
AV <sub>DD</sub> supply current	AI <sub>DD</sub>	Operating mode		2.0	6.0	mA	
A/D converter data retention current	AI <sub>DDDR</sub>	STOP mode	AV <sub>DDDR</sub> = 2.5 V		2	10	μA
			AV <sub>DDDR</sub> = 5 V ± 10 %		10	50	μA

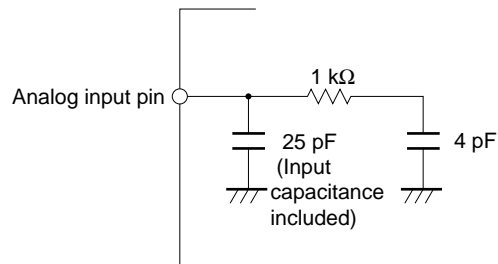
**Notes 1.** The quantization error is excluded.

**2.** When -0.3 V ≤ V<sub>IAN</sub> ≤ 0 V, the conversion result becomes 000H.

When 0 V < V<sub>IAN</sub> < AV<sub>REF</sub>, the conversion is performed with the 10-bit resolution.

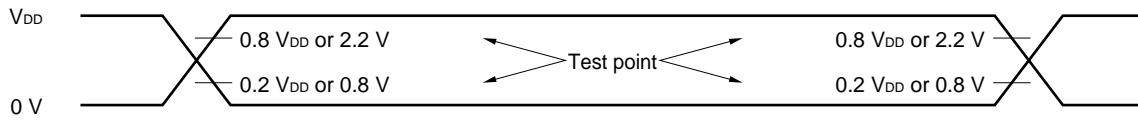
When AV<sub>REF</sub> ≤ V<sub>IAN</sub> ≤ +0.3 V, the conversion result becomes 3FFH.

**3.** The analog input impedance at the time of sampling is the same as the equivalent circuit shown below. (The values in the diagram are TYP. values; they are not guaranteed values)

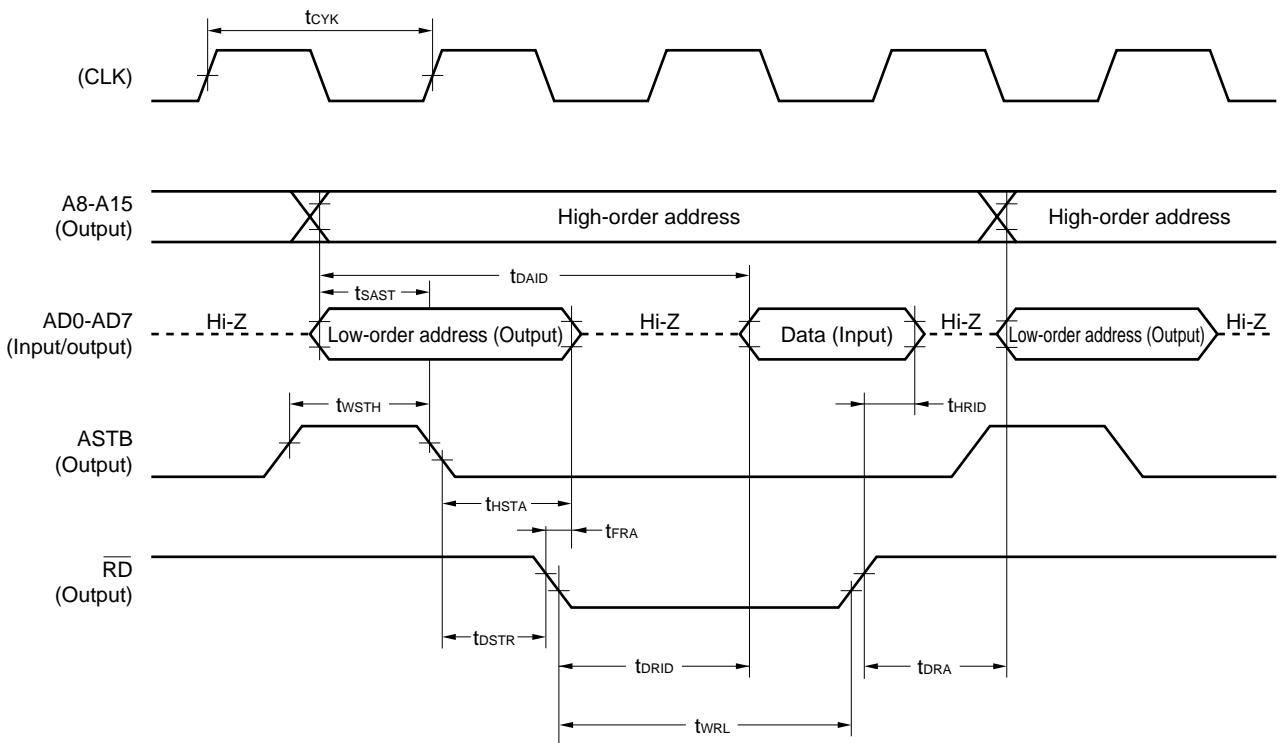


- Cautions**
1. When using the P70/ANI0-P77/ANI7 pins for both digital and analog inputs, the previously described characteristics are not guaranteed. Therefore, ensure that all of the eight P70/ANI0-P77/ANI7 pins are used either for analog input or digital input.
  2. When using the P70/ANI0-P77/ANI7 pins as digital input, make sure to set that  $AV_{DD} = V_{DD}$ , and  $AV_{SS} = V_{SS}$ .

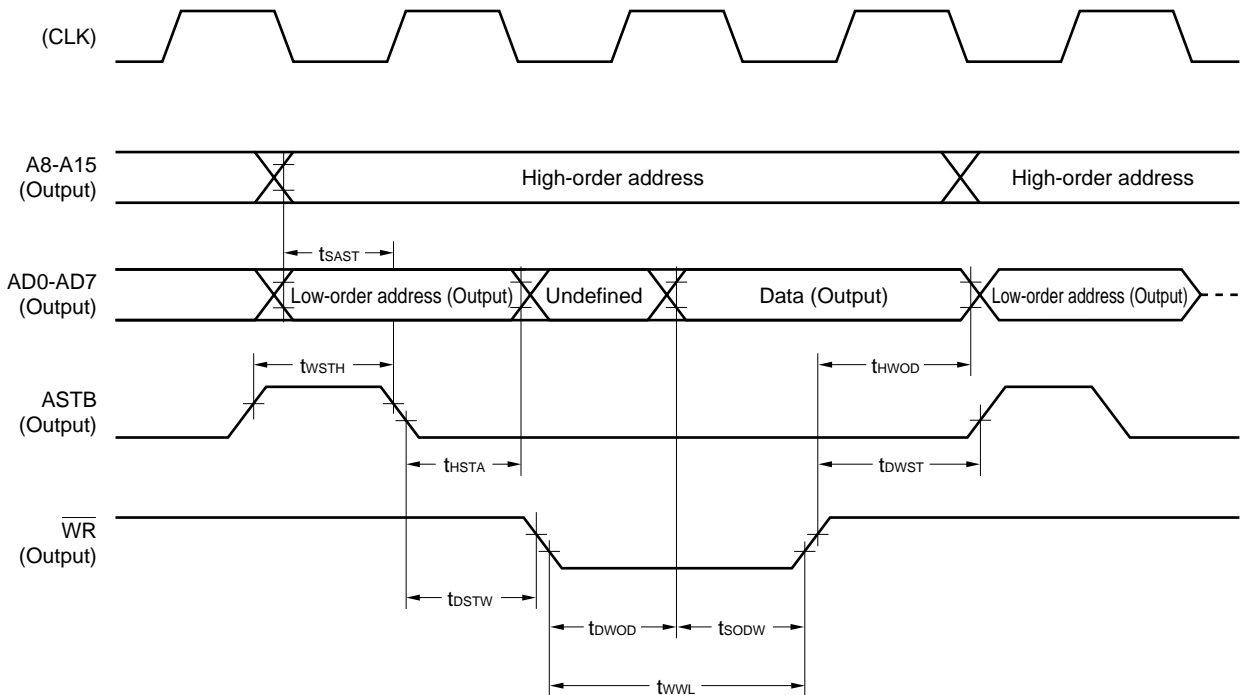
**AC Timing Test Point**



Read Operation

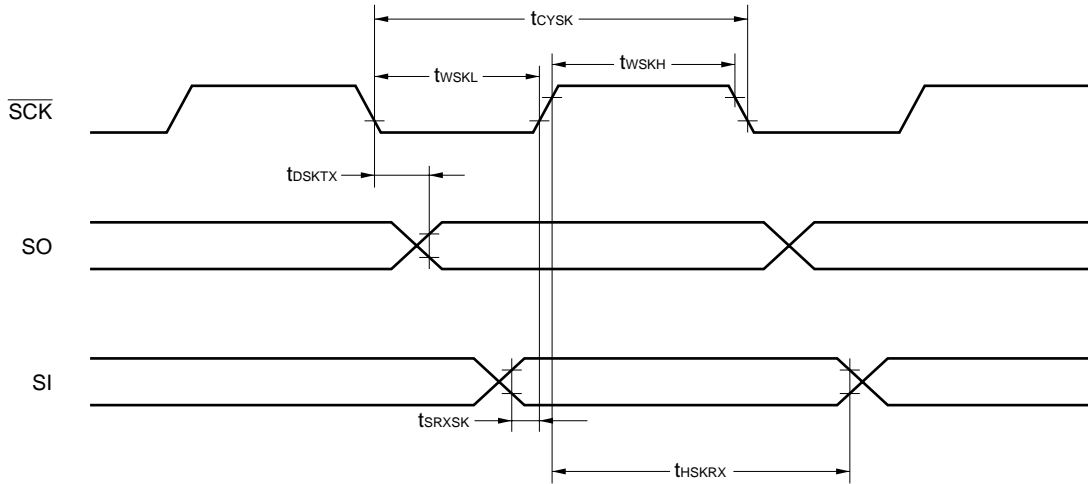


Write Operation

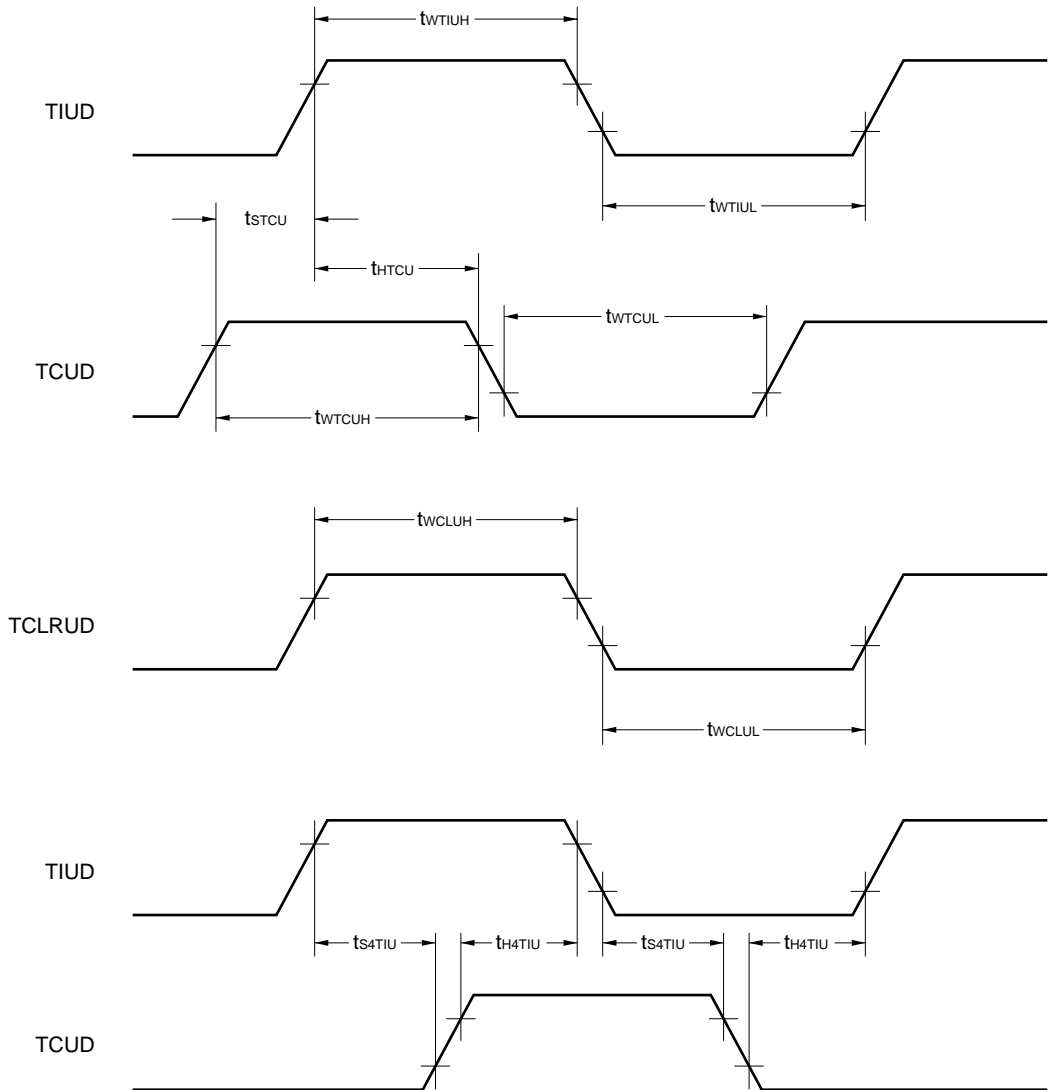




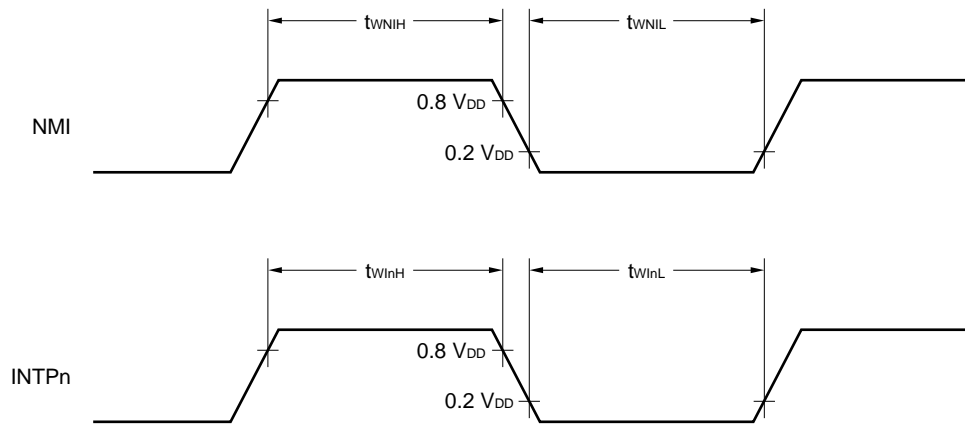
Serial Operation



Up/Down Counter (Timer 4) Input Timing

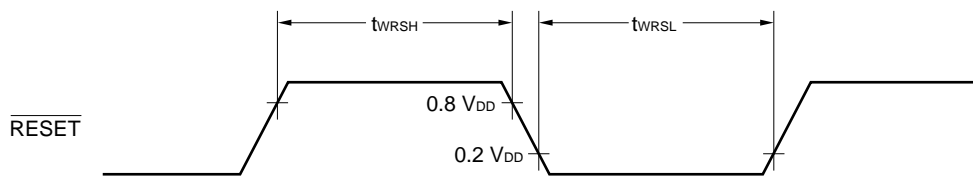


Interrupt Input Timing



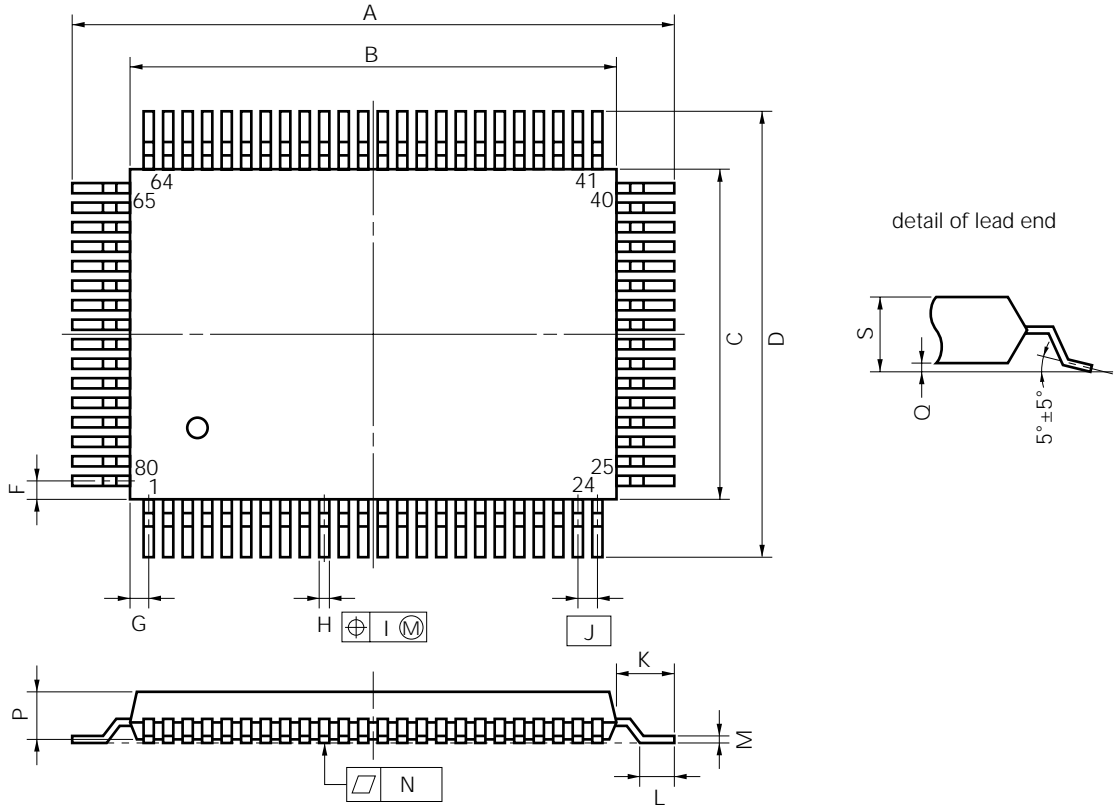
Remark n = 0 to 4

Reset Input Timing



11. PACKAGE DRAWING

80 PIN PLASTIC QFP (14×20)



P80GF-80-3B9-2

**NOTE**  
 Each lead centerline is located within 0.15 mm (0.006 inch) of its true position (T.P.) at maximum material condition.

ITEM	MILLIMETERS	INCHES
A	23.6±0.4	0.929±0.016
B	20.0±0.2	0.795 <sup>+0.009</sup> <sub>-0.008</sub>
C	14.0±0.2	0.551 <sup>+0.009</sup> <sub>-0.008</sub>
D	17.6±0.4	0.693±0.016
F	1.0	0.039
G	0.8	0.031
H	0.35±0.10	0.014 <sup>+0.004</sup> <sub>-0.005</sub>
I	0.15	0.006
J	0.8 (T.P.)	0.031 (T.P.)
K	1.8±0.2	0.071 <sup>+0.008</sup> <sub>-0.009</sub>
L	0.8±0.2	0.031 <sup>+0.009</sup> <sub>-0.008</sub>
M	0.15 <sup>+0.10</sup> <sub>-0.05</sub>	0.006 <sup>+0.004</sup> <sub>-0.003</sub>
N	0.15	0.006
P	2.7	0.106
Q	0.1±0.1	0.004±0.004
S	3.0 MAX.	0.119 MAX.

**12. RECOMMENDED SOLDERING CONDITIONS**

These products should be soldered and mounted under the conditions recommended below.

For details of recommended soldering conditions, refer to the information document **Semiconductor Device Mounting Technology Manual (C10535E)**.

For soldering methods and conditions other than those recommended, please contact your NEC sales representative.

★ **Table 12-1. Surface Mount Type Soldering Conditions**

μPD78363AGF-xxx-3B9: 80-Pin Plastic QFP (14 × 20 mm)

μPD78365AGF-3B9 : 80-Pin Plastic QFP (14 × 20 mm)

μPD78366AGF-xxx-3B9: 80-Pin Plastic QFP (14 × 20 mm)

μPD78368AGF-xxx-3B9: 80-Pin Plastic QFP (14 × 20 mm)

Soldering method	Soldering conditions	Recommended condition symbol
Infrared reflow	Package peak temperature: 235 °C, Duration: 30 sec. max. (210 °C or above) Number of times: 3 max.	IR35-00-3
VPS	Package peak temperature: 215 °C, Duration: 40 sec. max. (200 °C or above) Number of times: 3 max.	VP15-00-3
Wave soldering	Solder bath temperature: 260 °C or less, Time: 10 sec. max., Number of times: 1, Pre-heating temperature: 120 °C max. (Package surface temperature)	WS60-00-1
Partial heating	Pin temperature: 300 °C or less Duration: 3 sec. max. (per side of device)	—

**Caution Use of more than one soldering method should be avoided (except in the case of partial heating).**

APPENDIX A. DIFFERENCES BETWEEN μPD78366A AND μPD78328

Product name		μPD78366A	μPD78328
Item			
Minimum instruction execution time		125 ns [ internal clock : 16 MHz external clock : 8 MHz ]	250 ns [ internal clock : 8 MHz, external clock : 16 MHz ]
Internal memory	ROM	32K bytes	16K bytes
	RAM	2K bytes	512 bytes
Memory space		64K bytes (can be externally expanded)	
General-purpose registers		8 bits × 16 × 8 banks	
Number of basic instructions		115	111
Instruction set		<ul style="list-style-type: none"> <li>• 16-bit transfer/operation</li> <li>• Multiplication/division (16 bits × 16 bits, 32 bits ÷ 16 bits)</li> <li>• Bit manipulation</li> <li>• String</li> </ul>	
		<ul style="list-style-type: none"> <li>• Sum-of-products operation (16 bits × 16 bits + 32 bits)</li> <li>• Relative operation</li> </ul>	—
I/O lines	Input	14 (of which 8 are multiplexed with analog input)	11 (of which 8 are multiplexed with analog input)
	I/O	49	41
Real-time pulse unit		<ul style="list-style-type: none"> <li>• 16-bit timer × 5</li> <li>• 16-bit compare register × 7</li> <li>• 16-bit capture register × 3</li> <li>• 16-bit capture/compare register × 2</li> <li>• Two output modes selectable Mode 0, set-reset output : 6 channels Mode 1, buffer output : 6 channels</li> <li>• 16-bit resolution PWM output: 1 channel</li> </ul>	<ul style="list-style-type: none"> <li>• 16-bit timer × 3</li> <li>• 16-bit compare register × 14</li> <li>• 16-bit capture/compare register × 1</li> <li>• Two output modes selectable Mode 0, set-reset output : 6 channels toggle output : 1 channel Mode 1, buffer output : 8 channels</li> </ul>
Real-time output port		4 (buffer output in 4-bit units)	4/8 (buffer output in 4-/8-bit units)
PWM unit		8-/9-/10-/12-bit resolution variable PWM output: 2 channels	8-bit resolution PWM output: 1 channel
A/D converter		10-bit resolution, 8 channels	
Serial interface		Dedicated baud rate generator UART (with pin selection function) : 1 channel Clocked serial interface/SBI : 1 channel	Dedicated baud rate generator UART : 1 channel Clocked serial interface/SBI : 1 channel
Interrupt function		<ul style="list-style-type: none"> <li>• External: 6, internal: 14 (2 multiplexed with external)</li> <li>• 4 programmable priority levels</li> </ul>	
		<ul style="list-style-type: none"> <li>• Three processing selectable (vectored interrupt/macro service/context switching)</li> </ul>	
Test source		None	Internal: 1
PLL control circuit		Provided (external 8 MHz → internal: 16 MHz)	None
Package		<ul style="list-style-type: none"> <li>• 80-pin plastic QFP (14 × 20 mm)</li> </ul>	<ul style="list-style-type: none"> <li>• 64-pin plastic shrink DIP</li> <li>• 64-pin plastic QFP (14 × 20 mm)</li> </ul>
Others		<ul style="list-style-type: none"> <li>• Watchdog timer</li> <li>• Standby functions (HALT mode, STOP mode)</li> </ul>	

APPENDIX B. TOOLS

B.1 DEVELOPMENT TOOLS

The following development tools are available to support the system development using μPD78366A :

Language Processor

78K/III series relocatable assembler (RA78K3)	A relocatable assembler, that can be used commonly for the 78K/III series products. Since this assembler is provided with macro functions, it enhances the developmnt efficiency. A structured assembler, that can explicitly describe the program control structure, is also supplied, so that the program productivity and maintainability can be improved.			
	Host machine	OS	Supply media	Order code (product name)
	PC-9800 series	MS-DOS™	3.5" 2HD	μS5A13RA78K3
			5" 2HD	μS5A10RA78K3
	IBM PC/AT™ and its compatible model	PC DOS™	3.5" 2HC	μS7B13RA78K3
			5" 2HC	μS7B10RA78K3
	HP9000 series 700™	HP-UX™	DAT	μS3P16RA78K3
	SPARC station™	SunOS™	Cartridge tape	μS3K15RA78K3
NEWS™	NEWS-OS™	(QIC-24)	μS3R15RA78K3	
78K/III series C compiler (CC78K3)	This is a C compiler that can be commonly used for 78K/III series. This program converts the program written in C language to object codes microcomputer can execute. When using this compiler, the 78K/III series relocatable assembler (RA78K3) is necessary.			
	Host machine	OS	Supply media	Order code (product name)
	PC-9800 series	MS-DOS	3.5" 2HD	μS5A13CC78K3
			5" 2HD	μS5A10CC78K3
	IBM PC/AT and its compatible model	PC DOS	3.5" 2HC	μS7B13CC78K3
			5" 2HC	μS7B10CC78K3
	HP9000 series 700	HP-UX	DAT	μS3P16CC78K3
	SPARC station	SunOS	Cartridge tape	μS3K15CC78K3
NEWS	NEWS-OS	(QIC-24)	μS3R15CC78K3	

**Remark** The operations of the relocatable assembler and C compiler are guaranteed only on the specified host machine and OS described above.

**PROM Writing Tools**

Hardware	PG-1500	This is a PROM programmer that can program PROM-contained single-chip microcontrollers in standalone mode or under control of a host machine when the accessory board and an optional programmer adapter are connected. It can also program representative PROMs from 256K-bit to 4M-bit models.			
	PA-78P368GF PA-78P368KL	PROM programmer adapters that writes a program to the μPD78P368A on a general-purpose PROM programmer such as the PG-1500. PA-78P368GF: for μPD78P368AGF PA-78P368KL : for μPD78P368AKL			
Software	PG-1500 controller	Connects the PG-1500 and a host machine with a serial intrface and a parallel interface to control the PG-1500 from the host machine.			
		Host machine	OS	Supply media	Order code (part number)
		PC-9800 series	MS-DOS	3.5" 2HD	μS5A13PG1500
				5" 2HD	μS5A10PG1500
		IBM PC/AT and compatible machines	PC DOS	3.5" 2HC	μS7B13PG1500
	3.5" 2HC			μS7B10PG1500	

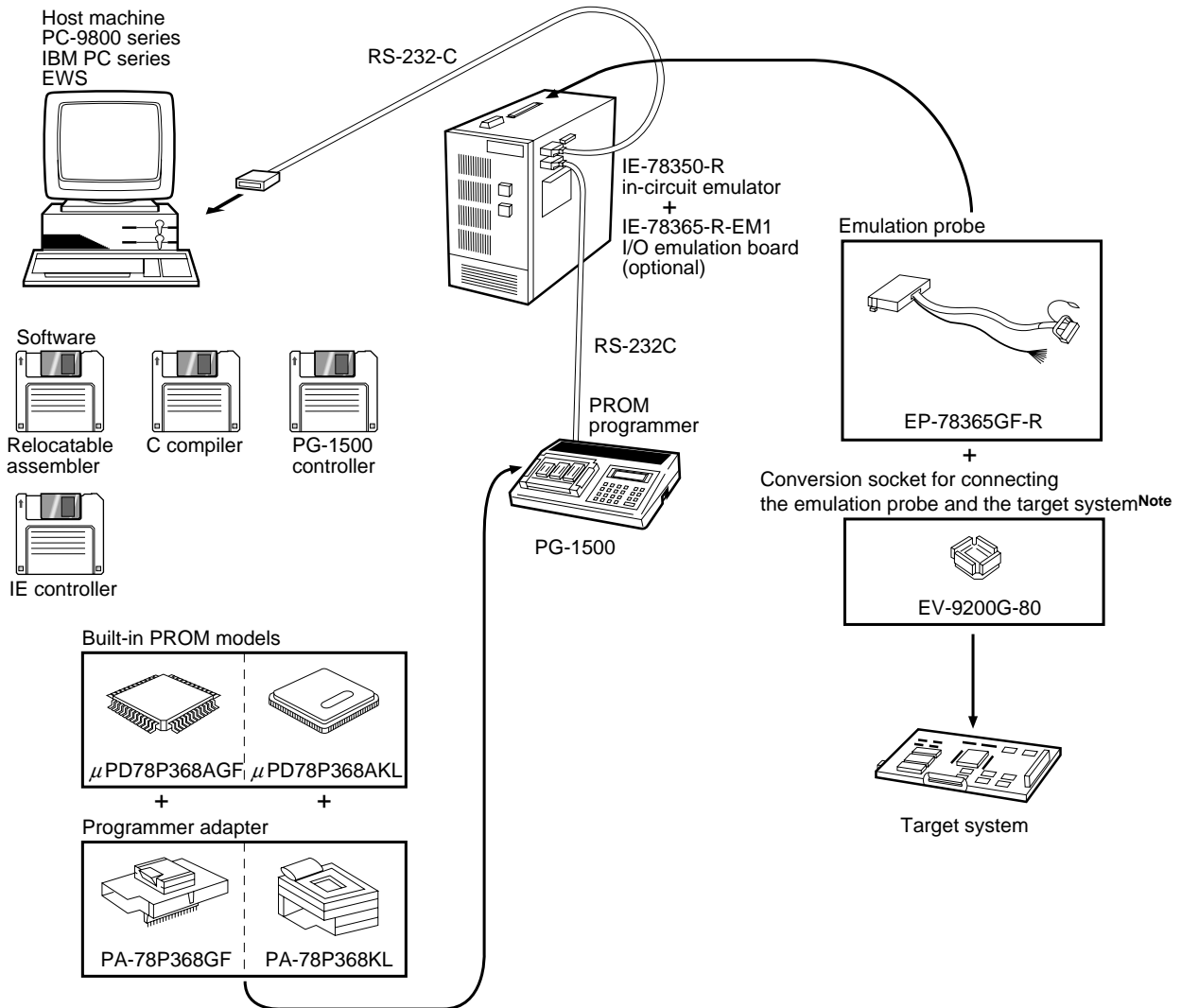
**Remark** The operation of the PG-1500 controller is guaranteed only on the above host machine and OS.

**Debugging Tools (When IE Controller Is Used)**

Hardware	IE-78350-R	In-circuit emulator that can be used to develop and debug application systems. Connected to a host machine for debugging.			
	IE-78365-R-EM1	I/O emulation board that emulates the peripheral functions of the target device such as I/O ports.			
	EP-78365GF-R EV-9200G-80	Emulation probe that connects the IE-78350-R to the target system. One conversion socket, EV-9200G-80, used to connect the target system is supplied as an accessory.			
Software	IE-78350-R control program (IE controller)	Program that controls the IE-78350-R on the host machine. It can automatically execute commands, enhancing debugging efficiency.			
		Host machine	OS	Supply media	Order code (part number)
		PC-9800 series	MS-DOS	3.5" 2HD	μS5A13IE78365A
				5" 2HD	μS5A10IE78365A
		IBM PC/AT and compatible machines	PC DOS	3.5" 2HC	μS7B13IE78365A
	3.5" 2HC			μS7B10IE78365A	

**Remark** The operation of the IE controller is guaranteed only on the above host machine and OS.

Development Tool Configuration (When Using IE Controller)



**Note** A socket is provided with the emulation probe.

- Remarks 1.** Host machine and PG-1500 can be directly connected by RS-232-C.  
**2.** 3.5-inch FD represents the supply media of software in this figure.

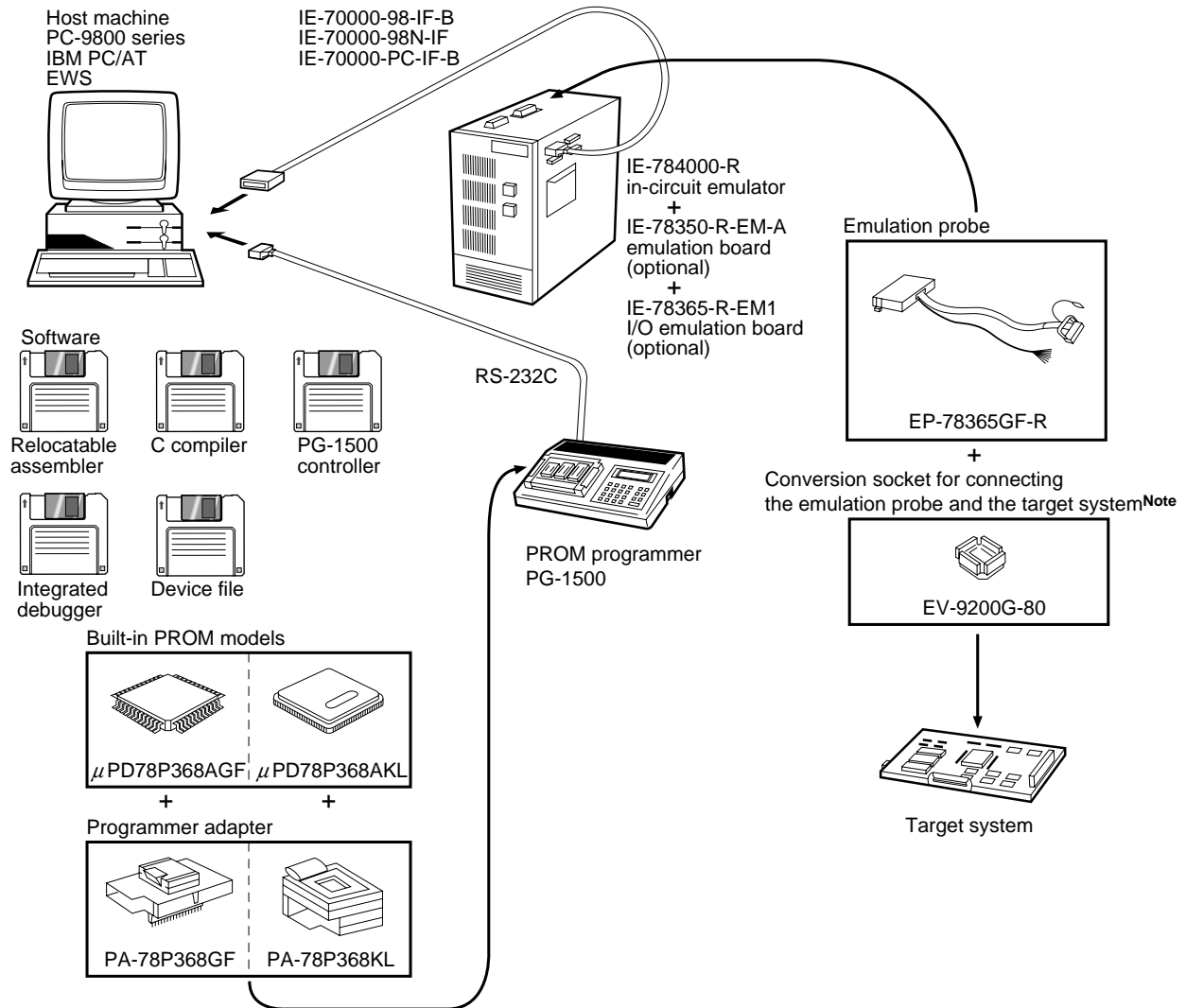


**Debugging Tools (When Integrated Debugger Is Used)**

Hardware	IE-784000-R	In-circuit emulation that can be used to develop and debug the application system. Connected to a host machine for debugging.			
	IE-78350-R-EM-A	Emulation board that emulates the peripheral functions of the target device such as I/O ports.			
	IE-78365-R-EM1	I/O emulation board that emulates the peripheral functions of the target device such as I/O ports.			
	EP-78365GF-R	Emulation probe connecting the IE-784000-R to the target system. One conversion socket, EV-9200G-80, used to connect the target system is supplied as an accessory.			
	EV-9200G-80				
	IE-70000-98-IF-B	Interface adapter to connect PC-9800 series (except notebook type personal computer) as the host machine.			
	IE-70000-98N-IF	Interface adapter and cable to connect PC-9800 series notebook type personal computer as the host machine.			
	IE-70000-PC-IF-B	Interface adapter and cable to connect IBM PC as the host machine.			
IE-78000-R-SV3	Interface board to connect EWS as the host machine.				
Software	Integrated debugger (ID78K3)	Program controlling the in-circuit emulator for the 78K/III series. Used in combination with a device file (DF78365). Can debug a program coded in the C language, structured assembly language, or assembly language at source program level. Can also split the screen of the host machine into windows on each of which information is displayed, enhancing debugging efficiency.			
		Host machine		Order code (part number)	
			OS	Supply media	
		PC-9800 series	MS-DOS	3.5" 2HD	μSAA13ID78K3
			Windows™	5" 2HD	μSAA10ID78K3
		IBM PC/AT and compatible machines (Japanese Windows)	PC DOS	3.5" 2HC	μSAB13ID78K3
			Windows	5" 2HC	μSAB10ID78K3
		IBM PC/AT and compatible machines (English Windows)		3.5" 2HC	μSBB13ID78K3
			5" 2HC	μSBB10ID78K3	
	Device File (DF78365)	File containing information peculiar to device. Use in combination with an assembler (RA78K3), C compiler (CC78K3), and integrated debugger (ID78K3).			
		Host machine		Order code (part number)	
			OS	Supply media	
PC-9800 series		MS-DOS	3.5" 2HD	μS5A13DF78365	
			5" 2HD	μS5A10DF78365	
IBM PC/AT and compatible machines		PC DOS	3.5" 2HC	μS7B13DF78365	
		5" 2HC	μS7B10DF78365		

**Remark** The operation of the integrated debugger and device file is guaranteed only on the above host machine and OS.

Development Tool Configuration (When Using Integrated Debugger)



**Note** A socket is provided with the emulation probe.

- Remarks 1.** Desk top-type PC represents host machine in this figure.  
**2.** 3.5-inch FD represents the supply media of software in this figure.

**B.2 EMBEDDED SOFTWARE**

The following embedded software is available for enhancing the efficiency of program development and maintenance.

**REAL-TIME OS**

Real-time OS (RX78K/III) <sup>Note</sup>	RX78K/III is intended to implement a multi-tasking environment for use in the control field where real-time capability is a must. It can allocate the idle time of the CPU to other processing to improve the overall performance of the system. RX78K/III provides system calls conforming to the μITRON specification. The RX78K/III package supplies a tool (configurator) to create the nucleus of RX78K/III and multiple information tables.			
	Host machine		Order code (part number)	
		OS	Supply media	
	PC-9800 series	MS-DOS	3.5" 2HD	Pending
			5" 2HD	Pending
IBM PC/AT and compatible machines	PC DOS	3.5" 2HC	Pending	
		5" 2HC	Pending	

**Note** Under development

**Caution** Before purchasing this product, you are requested to conclude a contract licensing use by filling out a specified form.

**Remark** When using the RX78K/III real-time OS, the RA78K3 assembler package (optional) is necessary.

Fuzzy Inference Development Support System

Fuzzy knowledge data creation tool (FE9000, FE9200)	Program that supports input/editing and evaluation (simulation) of fuzzy knowledge (fuzzy rules and membership functions).			
	Host machine	OS	Supply media	
	PC-9800 series	MS-DOS	3.5" 2HD	μS5A13FE9000
			5" 2HD	μS5A10FE9000
	IBM PC/AT and compatible machines	PC DOS + Windows	3.5" 2HC	μS7B13FE9200
5" 2HC			μS7B10FE9200	
Translator (FT78K3) <sup>Note</sup>	Program that converts the fuzzy knowledge data obtained by using the fuzzy knowledge data creation tool into assembler source program for the RA78K/III.			
	Host machine	OS	Supply media	
	PC-9800 series	MS-DOS	3.5" 2HD	μS5A13FT78K3
			5" 2HD	μS5A10FT78K3
	IBM PC/AT and compatible machines	PC DOS	3.5" 2HC	μS7B13FT78K3
5" 2HC			μS7B10FT78K3	
Fuzzy inference module (F178K/III) <sup>Note</sup>	Program that executes fuzzy inference when linked with the fuzzy knowledge data converted by the translator.			
	Host machine	OS	Supply media	
	PC-9800 series	MS-DOS	3.5" 2HD	μS5A13F178K3
			5" 2HD	μS5A10F178K3
	IBM PC/AT and compatible machines	PC DOS	3.5" 2HC	μS7B13F178K3
5" 2HC			μS7B10F178K3	
Fuzzy inference debugger (FD78K/III)	Support software that evaluates and adjusts the fuzzy knowledge data at the hardware level by using an in-circuit emulator.			
	Host machine	OS	Supply media	
	PC-9800 series	MS-DOS	3.5" 2HD	μS5A13FD78K3
			5" 2HD	μS5A10FD78K3
	IBM PC/AT and compatible machines	PC DOS	3.5" 2HC	μS7B13FD78K3
5" 2HC			μS7B10FD78K3	

**Note** Under development

[MEMO]

## NOTES FOR CMOS DEVICES

### ① PRECAUTION AGAINST ESD FOR SEMICONDUCTORS

**Note:** Strong electric field, when exposed to a MOS device, can cause destruction of the gate oxide and ultimately degrade the device operation. Steps must be taken to stop generation of static electricity as much as possible, and quickly dissipate it once, when it has occurred. Environmental control must be adequate. When it is dry, humidifier should be used. It is recommended to avoid using insulators that easily build static electricity. Semiconductor devices must be stored and transported in an anti-static container, static shielding bag or conductive material. All test and measurement tools including work bench and floor should be grounded. The operator should be grounded using wrist strap. Semiconductor devices must not be touched with bare hands. Similar precautions need to be taken for PW boards with semiconductor devices on it.

### ② HANDLING OF UNUSED INPUT PINS FOR CMOS

**Note:** No connection for CMOS device inputs can be cause of malfunction. If no connection is provided to the input pins, it is possible that an internal input level may be generated due to noise, etc., hence causing malfunction. CMOS device behave differently than Bipolar or NMOS devices. Input levels of CMOS devices must be fixed high or low by using a pull-up or pull-down circuitry. Each unused pin should be connected to  $V_{DD}$  or GND with a resistor, if it is considered to have a possibility of being an output pin. All handling related to the unused pins must be judged device by device and related specifications governing the devices.

### ③ STATUS BEFORE INITIALIZATION OF MOS DEVICES

**Note:** Power-on does not necessarily define initial status of MOS device. Production process of MOS does not define the initial operation status of the device. Immediately after the power source is turned ON, the devices with reset function have not yet been initialized. Hence, power-on does not guarantee out-pin levels, I/O settings or contents of registers. Device is not initialized until the reset signal is received. Reset operation must be executed immediately after power-on for devices having reset function.

## Regional Information

Some information contained in this document may vary from country to country. Before using any NEC product in your application, please contact the NEC office in your country to obtain a list of authorized representatives and distributors. They will verify:

- Device availability
- Ordering information
- Product release schedule
- Availability of related technical literature
- Development environment specifications (for example, specifications for third-party tools and components, host computers, power plugs, AC supply voltages, and so forth)
- Network requirements

In addition, trademarks, registered trademarks, export restrictions, and other legal issues may also vary from country to country.

**NEC Electronics Inc. (U.S.)**

Santa Clara, California  
 Tel: 800-366-9782  
 Fax: 800-729-9288

**NEC Electronics (Germany) GmbH**

Duesseldorf, Germany  
 Tel: 0211-65 03 02  
 Fax: 0211-65 03 490

**NEC Electronics (UK) Ltd.**

Milton Keynes, UK  
 Tel: 01908-691-133  
 Fax: 01908-670-290

**NEC Electronics Italiana s.r.l.**

Milano, Italy  
 Tel: 02-66 75 41  
 Fax: 02-66 75 42 99

**NEC Electronics (Germany) GmbH**

Benelux Office  
 Eindhoven, The Netherlands  
 Tel: 040-2445845  
 Fax: 040-2444580

**NEC Electronics (France) S.A.**

Velizy-Villacoublay, France  
 Tel: 01-30-67 58 00  
 Fax: 01-30-67 58 99

**NEC Electronics (France) S.A.**

Spain Office  
 Madrid, Spain  
 Tel: 01-504-2787  
 Fax: 01-504-2860

**NEC Electronics (Germany) GmbH**

Scandinavia Office  
 Taebly, Sweden  
 Tel: 08-63 80 820  
 Fax: 08-63 80 388

**NEC Electronics Hong Kong Ltd.**

Hong Kong  
 Tel: 2886-9318  
 Fax: 2886-9022/9044

**NEC Electronics Hong Kong Ltd.**

Seoul Branch  
 Seoul, Korea  
 Tel: 02-528-0303  
 Fax: 02-528-4411

**NEC Electronics Singapore Pte. Ltd.**

United Square, Singapore 1130  
 Tel: 253-8311  
 Fax: 250-3583

**NEC Electronics Taiwan Ltd.**

Taipei, Taiwan  
 Tel: 02-719-2377  
 Fax: 02-719-5951

**NEC do Brasil S.A.**

Sao Paulo-SP, Brasil  
 Tel: 011-889-1680  
 Fax: 011-889-1689

**MS-DOS and windows are either registered trademarks or trademarks of Microsoft Corporation in the United states and/or other countries.**

**PC/AT and PC DOS are trademarks of IBM Corporation.**

**HP9000 series 700 and HP-UX are trademarks of Hewlett-Packard Company.**

**SPARCstation is a trademark of SPARC International, Inc.**

**SunOS is a trademark of Sun Microsystems, Inc.**

**NEWS and NEWS-OS are trademarks of Sony Corporation.**

**TRON is an abbreviation of The Realtime Operating system Nucleus.**

**ITRON is an abbreviation of Industrial TRON.**

The export of these products from Japan is regulated by the Japanese government. The export of some or all of these products may be prohibited without governmental license. To export or re-export some or all of these products from a country other than Japan may also be prohibited without a license from that country. Please call an NEC sales representative.

Lisence not needed : μPD78365A

The customer must judge the need for license : μPD78363A, 78366A, 78368A

No part of this document may be copied or reproduced in any form or by any means without the prior written consent of NEC Corporation. NEC Corporation assumes no responsibility for any errors which may appear in this document.

NEC Corporation does not assume any liability for infringement of patents, copyrights or other intellectual property rights of third parties by or arising from use of a device described herein or any other liability arising from use of such device. No license, either express, implied or otherwise, is granted under any patents, copyrights or other intellectual property rights of NEC Corporation or others.

While NEC Corporation has been making continuous effort to enhance the reliability of its semiconductor devices, the possibility of defects cannot be eliminated entirely. To minimize risks of damage or injury to persons or property arising from a defect in an NEC semiconductor device, customers must incorporate sufficient safety measures in its design, such as redundancy, fire-containment, and anti-failure features.

NEC devices are classified into the following three quality grades:

"Standard", "Special", and "Specific". The Specific quality grade applies only to devices developed based on a customer designated "quality assurance program" for a specific application. The recommended applications of a device depend on its quality grade, as indicated below. Customers must check the quality grade of each device before using it in a particular application.

Standard: Computers, office equipment, communications equipment, test and measurement equipment, audio and visual equipment, home electronic appliances, machine tools, personal electronic equipment and industrial robots

Special: Transportation equipment (automobiles, trains, ships, etc.), traffic control systems, anti-disaster systems, anti-crime systems, safety equipment and medical equipment (not specifically designed for life support)

Specific: Aircrafts, aerospace equipment, submersible repeaters, nuclear reactor control systems, life support systems or medical equipment for life support, etc.

The quality grade of NEC devices is "Standard" unless otherwise specified in NEC's Data Sheets or Data Books. If customers intend to use NEC devices for applications other than those specified for Standard quality grade, they should contact an NEC sales representative in advance.

Anti-radioactive design is not implemented in this product.