



# NPN POWER DARLINGTON TRANSISTOR ARRAY

**D78A3D2**

**100 VOLTS  
3 AMP, 25 WATTS**

Designed for high power switching applications, hammer drive, pulse motor drive and inductive load drive applications.

**Features:**

- High reliability small-sized available (4 in 1)
- Epoxy single-inline package with heat sink (12 pin)
- High collector power dissipation:  $P_D = 25W @ T_A = 25^\circ C$  (Four device action)
- High collector current:  $I_C = 3A$  (Max.)
- High DC current gain:  $h_{FE} = 2000$  (Min.) @  $V_{CE} = 2V$ ,  $I_C = 1.5A$

ARRAY CONFIGURATION

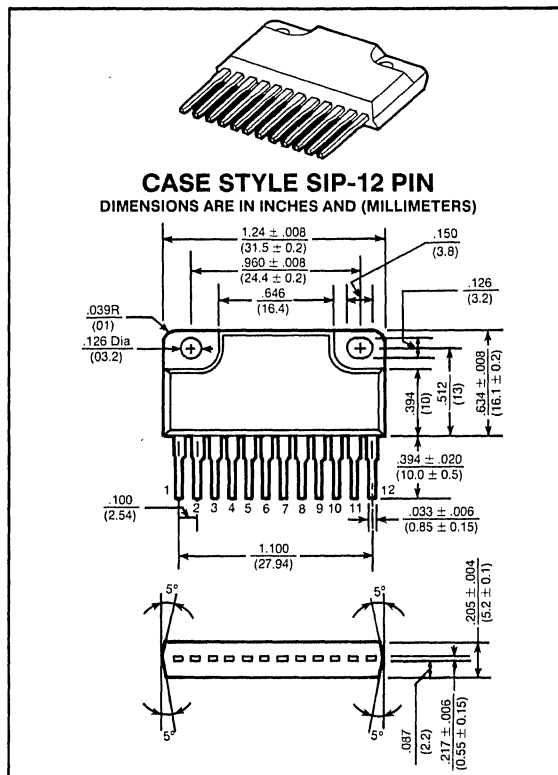
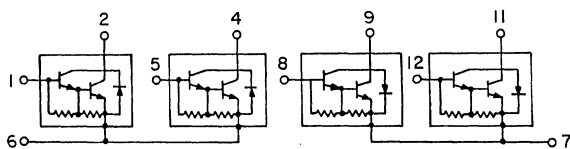

maximum ratings ( $T_A = 25^\circ C$ ) (unless otherwise specified)

RATING	SYMBOL	D78A3D2	UNITS
Collector-Emitter Voltage	$V_{CEO}$	100	Volts
Collector-Base Voltage	$V_{CBO}$	120	Volts
Emitter Base Voltage	$V_{EBO}$	6	Volts
Collector Current — Continuous	$I_C$	3	A
Peak	$I_{CM}$	6	A
Base Current — Continuous	$I_B$	0.5	A
Maximum Forward Current	$I_{FM}$	3	A
Surge Current (1 sec)	$I_{FSM}$	6	A
Reverse Voltage	$V_R$	100	A
Collector Power Dissipation (One Device Action, $T_A = 25^\circ C$ )	$P_D$	3.0	Watts
Collector Power Dissipation (Four Device Action)	$P_D$	$T_A = 25^\circ C$ 25	Watts
Isolation Voltage (Between Fin to 1 ~ 12 pin)	$V_{Isol}$	1000	Volts
Operating and Storage Junction Temperature Range	$T_J, T_{STG}$	-55 to +150	$^\circ C$

## thermal characteristics

Thermal Resistance, Junction to Case	$R_{\theta JC}$	5	$^{\circ}\text{C/W}$
Thermal Resistance, Junction to Ambient	$R_{\theta JA}$	25	$^{\circ}\text{C/W}$
Maximum Lead Temperature for Soldering Purpose: $\frac{1}{16}$ " from Case for 5 Seconds	$T_L$	260	$^{\circ}\text{C}$

## electrical characteristics ( $T_C = 25^{\circ}\text{C}$ ) (unless otherwise specified)

CHARACTERISTIC	SYMBOL	MIN	TYP	MAX	UNIT
----------------	--------	-----	-----	-----	------

## off characteristics

Collector-Emitter Breakdown Voltage ( $I_C = 10\text{mA}, I_B = 0$ )	$V_{BR(CEO)}$	100	—	—	Volts
Collector-Base Breakdown Voltage ( $I_C = 1\text{mA}, I_E = 0$ )	$V_{BR(CBO)}$	120	—	—	Volts
Collector Cutoff Current ( $V_{CB} = 120\text{V}, I_E = 0$ )	$I_{CBO}$	—	—	10	$\mu\text{A}$
Collector Cutoff Current ( $V_{CE} = 100\text{V}, I_B = 0$ )	$I_{CEO}$	—	—	10	$\mu\text{A}$
Emitter Cutoff Current ( $V_{EB} = 6\text{V}, I_C = 0$ )	$I_{EBO}$	0.5	—	2.5	mA

## second breakdown

Second Breakdown with Base Forward Biased	FBSOA	SEE FIGURE 13
---	-------	---------------

## on characteristics

DC Current Gain ( $I_C = 1.5\text{A}, V_{CE} = 2\text{V}$ ) ( $I_C = 3\text{A}, V_{CE} = 2\text{V}$ )	$h_{FE}$	2000 1000	— —	12000 —	—
Collector-Emitter Saturation Voltage ( $I_C = 1.5\text{A}, I_B = 3\text{mA}$ )	$V_{CE(sat)}$	—	—	1.5	Volts
Base-Emitter Saturation Voltage ( $I_C = 1.5\text{A}, I_B = 3\text{mA}$ )	$V_{BE(sat)}$	—	—	2.0	Volts

## switching characteristics

Turn-on Time	$V_{CC} = 30\text{V}$ $I_{B1} = -I_{B2} = 3\text{mA}$ Duty Cycle = 1%	$t_{on}$	—	0.3	—	$\mu\text{s}$
Storage Time		$t_{stg}$	—	2	—	
Fall Time		$t_f$	—	0.4	—	

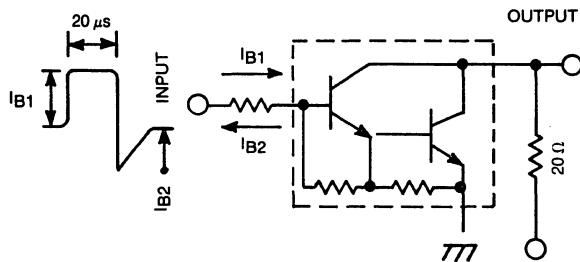

FIG. 1 SWITCHING TIME TEST CIRCUIT

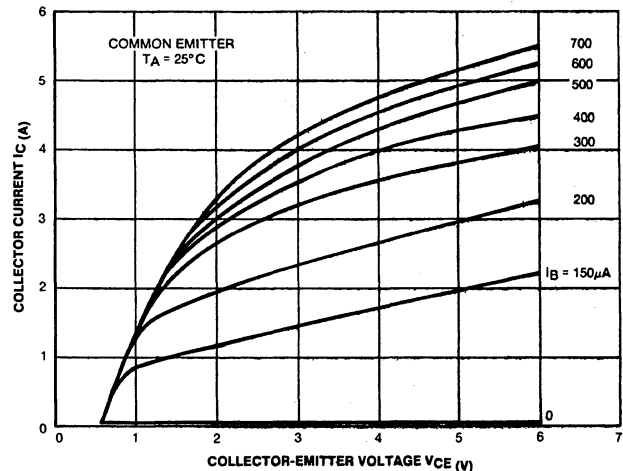

FIG. 2  $I_C - V_{CE}$

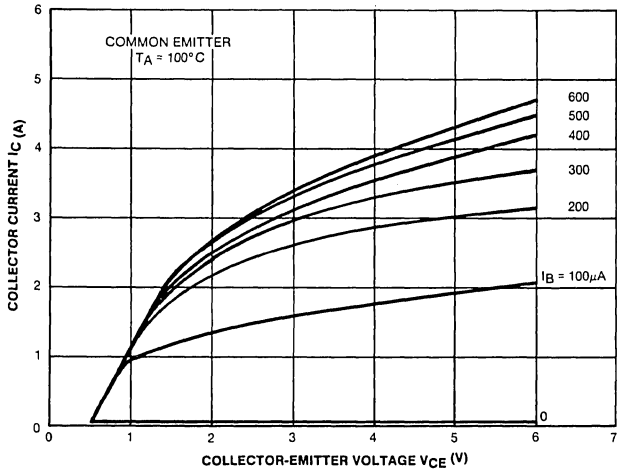

FIG. 3 IC - VCE

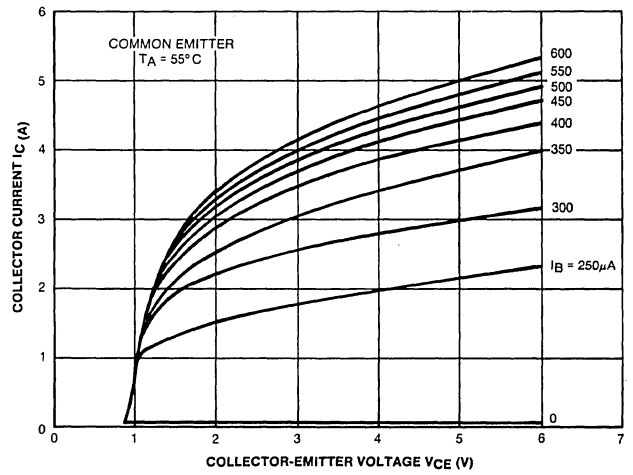

FIG. 4 IC - VCE

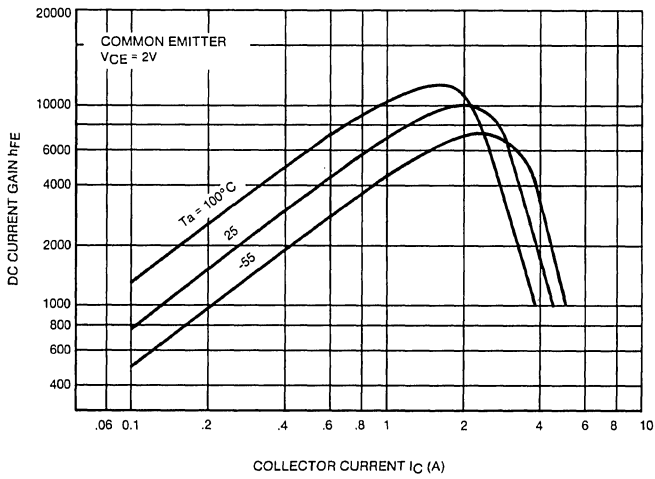

FIG. 5 hFE - IC

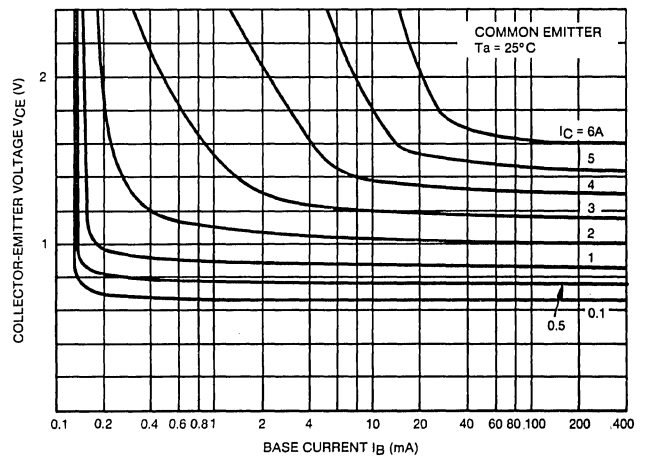

FIG. 6 IB - VCE

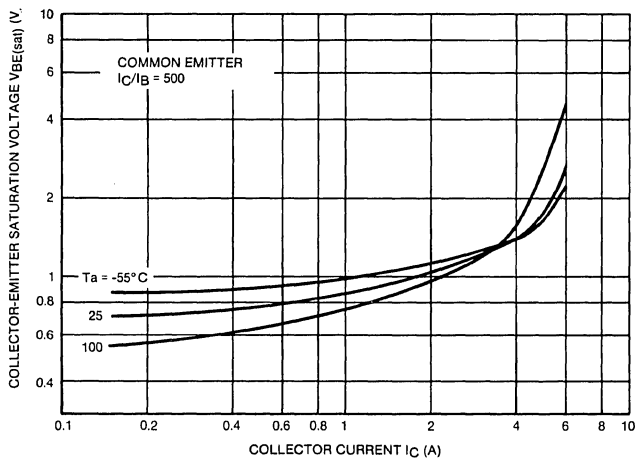

FIG. 7 VCE(sat) - IC

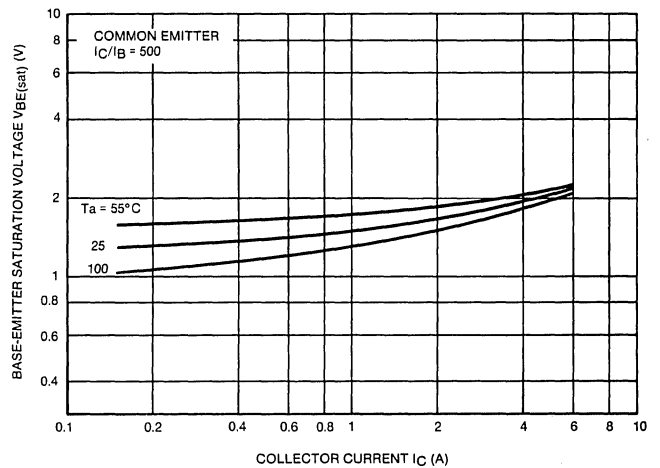

FIG. 8 VBE(sat) - IC

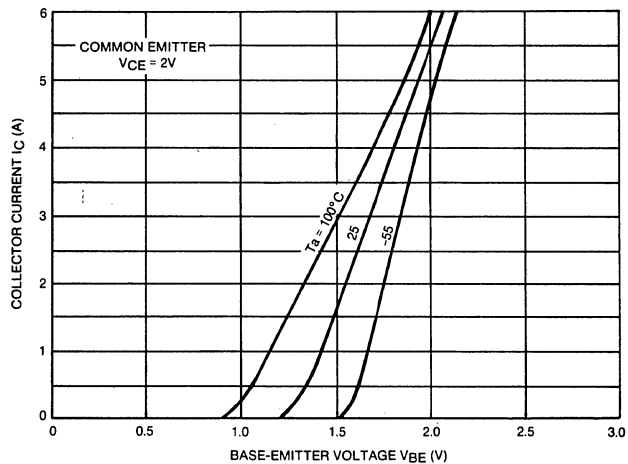

FIG. 9 I<sub>C</sub> - V<sub>BE</sub>

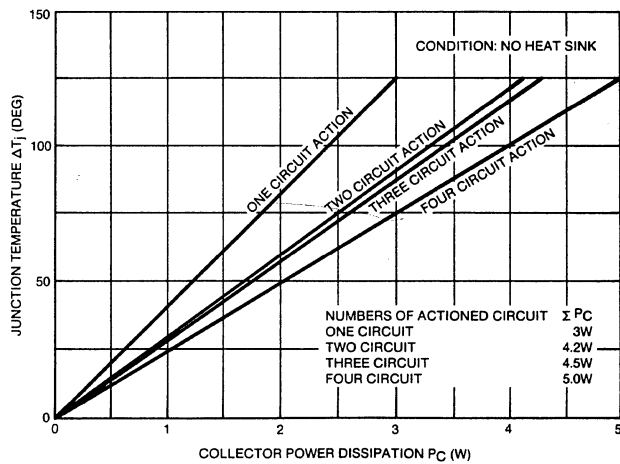

FIG. 10

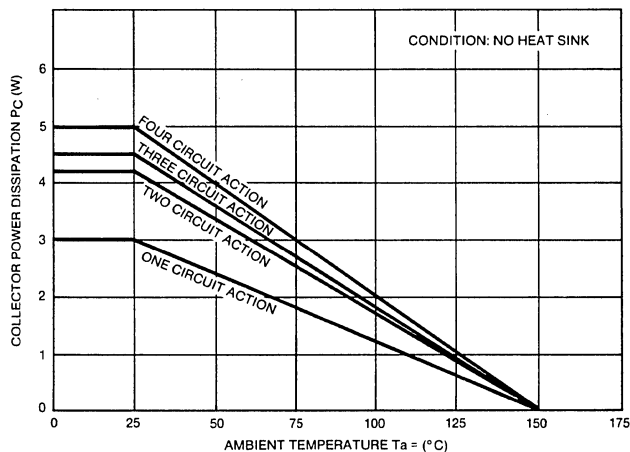

FIG. 11 TOTAL COLLECTOR POWER DISSIPATION

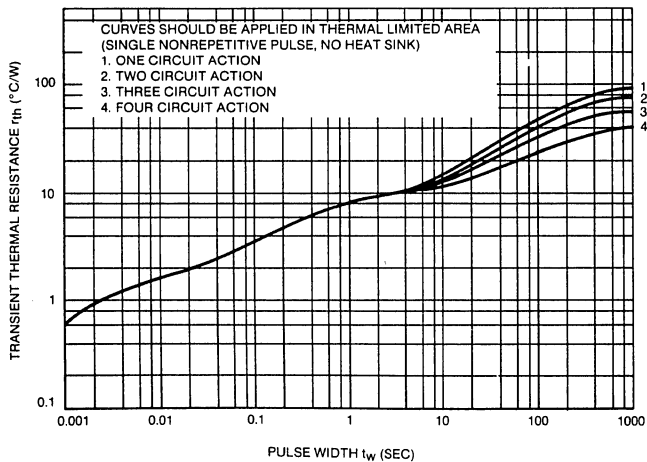

FIG. 12 r<sub>th</sub> - t<sub>w</sub>

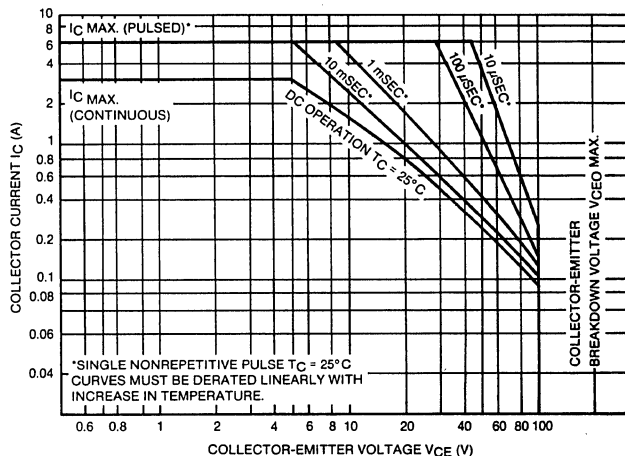

FIG. 13 SAFE OPERATING AREA