

Preliminary User's Manual

78K0/KE2

8-Bit Single-Chip Microcontrollers

***μ*PD78F0531**

***μ*PD78F0532**

***μ*PD78F0533**

***μ*PD78F0534**

***μ*PD78F0535**

***μ*PD78F0536**

***μ*PD78F0537**

***μ*PD78F0537D**

The *μ*PD78F0537D has an on-chip debug function.

Do not use this product for mass production because its reliability cannot be guaranteed after the on-chip debug function has been used, due to issues with respect to the number of times the flash memory can be rewritten. NEC Electronics

[MEMO]

NOTES FOR CMOS DEVICES

① VOLTAGE APPLICATION WAVEFORM AT INPUT PIN

Waveform distortion due to input noise or a reflected wave may cause malfunction. If the input of the CMOS device stays in the area between V_{IL} (MAX) and V_{IH} (MIN) due to noise, etc., the device may malfunction. Take care to prevent chattering noise from entering the device when the input level is fixed, and also in the transition period when the input level passes through the area between V_{IL} (MAX) and V_{IH} (MIN).

② HANDLING OF UNUSED INPUT PINS

Unconnected CMOS device inputs can be cause of malfunction. If an input pin is unconnected, it is possible that an internal input level may be generated due to noise, etc., causing malfunction. CMOS devices behave differently than Bipolar or NMOS devices. Input levels of CMOS devices must be fixed high or low by using pull-up or pull-down circuitry. Each unused pin should be connected to V_{DD} or GND via a resistor if there is a possibility that it will be an output pin. All handling related to unused pins must be judged separately for each device and according to related specifications governing the device.

③ PRECAUTION AGAINST ESD

A strong electric field, when exposed to a MOS device, can cause destruction of the gate oxide and ultimately degrade the device operation. Steps must be taken to stop generation of static electricity as much as possible, and quickly dissipate it when it has occurred. Environmental control must be adequate. When it is dry, a humidifier should be used. It is recommended to avoid using insulators that easily build up static electricity. Semiconductor devices must be stored and transported in an anti-static container, static shielding bag or conductive material. All test and measurement tools including work benches and floors should be grounded. The operator should be grounded using a wrist strap. Semiconductor devices must not be touched with bare hands. Similar precautions need to be taken for PW boards with mounted semiconductor devices.

④ STATUS BEFORE INITIALIZATION

Power-on does not necessarily define the initial status of a MOS device. Immediately after the power source is turned ON, devices with reset functions have not yet been initialized. Hence, power-on does not guarantee output pin levels, I/O settings or contents of registers. A device is not initialized until the reset signal is received. A reset operation must be executed immediately after power-on for devices with reset functions.

⑤ POWER ON/OFF SEQUENCE

In the case of a device that uses different power supplies for the internal operation and external interface, as a rule, switch on the external power supply after switching on the internal power supply. When switching the power supply off, as a rule, switch off the external power supply and then the internal power supply. Use of the reverse power on/off sequences may result in the application of an overvoltage to the internal elements of the device, causing malfunction and degradation of internal elements due to the passage of an abnormal current.

The correct power on/off sequence must be judged separately for each device and according to related specifications governing the device.

⑥ INPUT OF SIGNAL DURING POWER OFF STATE

Do not input signals or an I/O pull-up power supply while the device is not powered. The current injection that results from input of such a signal or I/O pull-up power supply may cause malfunction and the abnormal current that passes in the device at this time may cause degradation of internal elements. Input of signals during the power off state must be judged separately for each device and according to related specifications governing the device.

EEPROM is a trademark of NEC Electronics Corporation.

Windows and Windows NT are registered trademarks or trademarks of Microsoft Corporation in the United States and/or other countries.

PC/AT is a trademark of International Business Machines Corporation.

HP9000 series 700 and HP-UX are trademarks of Hewlett-Packard Company.

SPARCstation is a trademark of SPARC International, Inc.

Solaris and SunOS are trademarks of Sun Microsystems, Inc.

SuperFlash® is a registered trademark of Silicon Storage Technology, Inc. in several countries including the United States and Japan.

Caution: This product uses SuperFlash® technology licensed from Silicon Storage Technology, Inc.

- **The information contained in this document is being issued in advance of the production cycle for the product. The parameters for the product may change before final production or NEC Electronics Corporation, at its own discretion, may withdraw the product prior to its production.**
- **Not all products and/or types are available in every country. Please check with an NEC Electronics sales representative for availability and additional information.**
- No part of this document may be copied or reproduced in any form or by any means without the prior written consent of NEC Electronics. NEC Electronics assumes no responsibility for any errors that may appear in this document.
- NEC Electronics does not assume any liability for infringement of patents, copyrights or other intellectual property rights of third parties by or arising from the use of NEC Electronics products listed in this document or any other liability arising from the use of such products. No license, express, implied or otherwise, is granted under any patents, copyrights or other intellectual property rights of NEC Electronics or others.
- Descriptions of circuits, software and other related information in this document are provided for illustrative purposes in semiconductor product operation and application examples. The incorporation of these circuits, software and information in the design of a customer's equipment shall be done under the full responsibility of the customer. NEC Electronics assumes no responsibility for any losses incurred by customers or third parties arising from the use of these circuits, software and information.
- While NEC Electronics endeavors to enhance the quality, reliability and safety of NEC Electronics products, customers agree and acknowledge that the possibility of defects thereof cannot be eliminated entirely. To minimize risks of damage to property or injury (including death) to persons arising from defects in NEC Electronics products, customers must incorporate sufficient safety measures in their design, such as redundancy, fire-containment and anti-failure features.
- NEC Electronics products are classified into the following three quality grades: "Standard", "Special" and "Specific". The "Specific" quality grade applies only to NEC Electronics products developed based on a customer-designated "quality assurance program" for a specific application. The recommended applications of an NEC Electronics products depend on its quality grade, as indicated below. Customers must check the quality grade of each NEC Electronics product before using it in a particular application.
 - "Standard": Computers, office equipment, communications equipment, test and measurement equipment, audio and visual equipment, home electronic appliances, machine tools, personal electronic equipment and industrial robots.
 - "Special": Transportation equipment (automobiles, trains, ships, etc.), traffic control systems, anti-disaster systems, anti-crime systems, safety equipment and medical equipment (not specifically designed for life support).
 - "Specific": Aircraft, aerospace equipment, submersible repeaters, nuclear reactor control systems, life support systems and medical equipment for life support, etc.

The quality grade of NEC Electronics products is "Standard" unless otherwise expressly specified in NEC Electronics data sheets or data books, etc. If customers wish to use NEC Electronics products in applications not intended by NEC Electronics, they must contact an NEC Electronics sales representative in advance to determine NEC Electronics' willingness to support a given application.

(Note)

- (1) "NEC Electronics" as used in this statement means NEC Electronics Corporation and also includes its majority-owned subsidiaries.
- (2) "NEC Electronics products" means any product developed or manufactured by or for NEC Electronics (as defined above).

Regional Information

Some information contained in this document may vary from country to country. Before using any NEC Electronics product in your application, please contact the NEC Electronics office in your country to obtain a list of authorized representatives and distributors. They will verify:

- Device availability
- Ordering information
- Product release schedule
- Availability of related technical literature
- Development environment specifications (for example, specifications for third-party tools and components, host computers, power plugs, AC supply voltages, and so forth)
- Network requirements

In addition, trademarks, registered trademarks, export restrictions, and other legal issues may also vary from country to country.

[GLOBAL SUPPORT]

<http://www.necel.com/en/support/support.html>

NEC Electronics America, Inc. (U.S.)

Santa Clara, California
Tel: 408-588-6000
800-366-9782

NEC Electronics (Europe) GmbH

Duesseldorf, Germany
Tel: 0211-65030

NEC Electronics Hong Kong Ltd.

Hong Kong
Tel: 2886-9318

- **Sucursal en España**

Madrid, Spain
Tel: 091-504 27 87

- **Succursale Française**

Vélizy-Villacoublay, France
Tel: 01-30-67 58 00

- **Filiale Italiana**

Milano, Italy
Tel: 02-66 75 41

- **Branch The Netherlands**

Eindhoven, The Netherlands
Tel: 040-265 40 10

- **Tyskland Filial**

Taebby, Sweden
Tel: 08-63 87 200

- **United Kingdom Branch**

Milton Keynes, UK
Tel: 01908-691-133

NEC Electronics Hong Kong Ltd.

Seoul Branch
Seoul, Korea
Tel: 02-558-3737

NEC Electronics Shanghai Ltd.

Shanghai, P.R. China
Tel: 021-5888-5400

NEC Electronics Taiwan Ltd.

Taipei, Taiwan
Tel: 02-2719-2377

NEC Electronics Singapore Pte. Ltd.

Novena Square, Singapore
Tel: 6253-8311

J05.6

INTRODUCTION

Readers This manual is intended for user engineers who wish to understand the functions of the 78K0/KE2 and design and develop application systems and programs for these devices. The target products are as follows.

78K0/KE2: μ PD78F0531, 78F0532, 78F0533, 78F0534, 78F0535, 78F0536, 78F0537, 78F0537D

Purpose This manual is intended to give users an understanding of the functions described in the **Organization** below.

Organization The 78K0/KE2 manual is separated into two parts: this manual and the instructions edition (common to the 78K/0 Series).

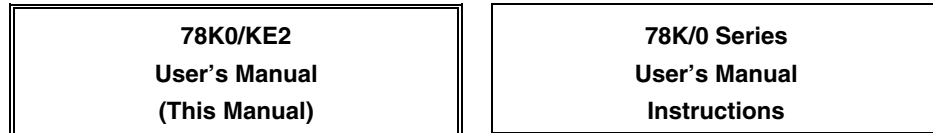

- Pin functions
- Internal block functions
- Interrupts
- Other on-chip peripheral functions
- Electrical specifications (target)
- CPU functions
- Instruction set
- Explanation of each instruction

How to Read This Manual It is assumed that the readers of this manual have general knowledge of electrical engineering, logic circuits, and microcontrollers.

- To gain a general understanding of functions:
 - Read this manual in the order of the **CONTENTS**. The mark ★ shows major revised points.
- How to interpret the register format:
 - For a bit number enclosed in angle brackets, the bit name is defined as a reserved word in the RA78K0, and is defined as an sfr variable using the #pragma sfr directive in the CC78K0.
- To check the details of a register when you know the register name:
 - See **APPENDIX C REGISTER INDEX**.
- To know details of the 78K/0 Series instructions:
 - Refer to the separate document **78K/0 Series Instructions User's Manual (U12326E)**.

Conventions

Data significance: Higher digits on the left and lower digits on the right

Active low representations: $\overline{\text{xxx}}$ (overscore over pin and signal name)

Note

Other Documents

Document Name	Document No.
SEMICONDUCTOR SELECTION GUIDE – Products and Packages –	X13769X
Semiconductor Device Mount Manual	Note
Quality Grades on NEC Semiconductor Devices	C11531E
NEC Semiconductor Device Reliability/Quality Control System	C10983E
Guide to Prevent Damage for Semiconductor Devices by Electrostatic Discharge (ESD)	C11892E

Note See the “Semiconductor Device Mount Manual” website (<http://www.necel.com/pkg/en/mount/index.html>).

Caution The related documents listed above are subject to change without notice. Be sure to use the latest version of each document when designing.

CONTENTS

CHAPTER 1 OUTLINE	17
1.1 Features	17
1.2 Applications	18
1.3 Ordering Information	19
1.4 Pin Configuration (Top View)	23
1.5 78K0/Kx2 Series Lineup	26
1.6 Block Diagram	29
1.7 Outline of Functions	30
CHAPTER 2 PIN FUNCTIONS	32
2.1 Pin Function List	32
2.2 Description of Pin Functions	36
2.2.1 P00 to P06 (port 0).....	36
2.2.2 P10 to P17 (port 1).....	37
2.2.3 P20 to P27 (port 2).....	38
2.2.4 P30 to P33 (port 3).....	38
2.2.5 P40 to P43 (port 4).....	39
2.2.6 P50 to P53 (port 5).....	39
2.2.7 P60 to P63 (port 6).....	39
2.2.8 P70 to P77 (port 7).....	39
2.2.9 P120 to P124 (port 12).....	40
2.2.10 P130 (port 13).....	40
2.2.11 P140, P141 (port 14).....	41
2.2.12 AV _{REF}	41
2.2.13 AV _{SS}	41
2.2.14 $\overline{\text{RESET}}$	41
2.2.15 REGC.....	41
2.2.16 V _{DD} and EV _{DD}	42
2.2.17 V _{SS} and EV _{SS}	42
2.2.18 FLMD0	42
2.3 Pin I/O Circuits and Recommended Connection of Unused Pins	43
CHAPTER 3 CPU ARCHITECTURE	47
3.1 Memory Space	47
3.1.1 Internal program memory space	56
3.1.2 Memory bank (μ PD78F0536, 78F0537, and 78F0537D only).....	58
3.1.3 Internal data memory space.....	58
3.1.4 Special function register (SFR) area	59
3.1.5 Data memory addressing.....	59
3.2 Processor Registers	67
3.2.1 Control registers.....	67
3.2.2 General-purpose registers	71
3.2.3 Special function registers (SFRs).....	72

6.1	Functions of Clock Generator	134
6.2	Configuration of Clock Generator.....	135
6.3	Registers Controlling Clock Generator	137
6.4	System Clock Oscillator.....	146
6.4.1	X1 oscillator	146
6.4.2	XT1 oscillator	146
6.4.3	When subsystem clock is not used	149
6.4.4	Internal high-speed oscillator	149
6.4.5	Internal low-speed oscillator.....	149
6.4.6	Prescaler	149
6.5	Clock Generator Operation.....	150
6.6	Controlling Clock.....	153
6.6.1	Controlling high-speed system clock.....	153
6.6.2	Example of controlling internal high-speed oscillation clock.....	156
6.6.3	Example of controlling subsystem clock.....	158
6.6.4	Example of controlling internal low-speed oscillation clock	160
6.6.5	Clocks supplied to CPU and peripheral hardware.....	160
6.6.6	CPU clock status transition diagram	161
6.6.7	Condition before changing CPU clock and processing after changing CPU clock	166
★ 6.6.8	Time required for switchover of CPU clock and main system clock	167
★ 6.6.9	Conditions before clock oscillation is stopped.....	168
★ 6.6.10	Peripheral hardware and source clocks	169
CHAPTER 7 16-BIT TIMER/EVENT COUNTERS 00 AND 01		170
7.1	Functions of 16-Bit Timer/Event Counters 00 and 01	170
7.2	Configuration of 16-Bit Timer/Event Counters 00 and 01	171
7.3	Registers Controlling 16-Bit Timer/Event Counters 00 and 01	176
7.4	Operation of 16-Bit Timer/Event Counters 00 and 01	188
7.4.1	Interval timer operation	188
7.4.2	Square wave output operation	191
7.4.3	External event counter operation	194
7.4.4	Operation in clear & start mode entered by TI00n pin valid edge input.....	197
7.4.5	Free-running timer operation.....	213
7.4.6	PPG output operation.....	222
7.4.7	One-shot pulse output operation	225
7.4.8	Pulse width measurement operation	230
7.5	Special Use of TM0n	239
7.5.1	Rewriting CR01n during TM0n operation	239
7.5.2	Setting LVS0n and LVR0n	239
7.6	Cautions for 16-Bit Timer/Event Counters 00 and 01.....	241
CHAPTER 8 8-BIT TIMER/EVENT COUNTERS 50 AND 51		245
8.1	Functions of 8-Bit Timer/Event Counters 50 and 51	245
8.2	Configuration of 8-Bit Timer/Event Counters 50 and 51	245
8.3	Registers Controlling 8-Bit Timer/Event Counters 50 and 51	248
8.4	Operations of 8-Bit Timer/Event Counters 50 and 51	253
8.4.1	Operation as interval timer	253
8.4.2	Operation as external event counter	255

8.4.3	Square-wave output operation	256
8.4.4	PWM output operation.....	257
8.5	Cautions for 8-Bit Timer/Event Counters 50 and 51	261
CHAPTER 9	8-BIT TIMERS H0 AND H1	262
9.1	Functions of 8-Bit Timers H0 and H1	262
9.2	Configuration of 8-Bit Timers H0 and H1.....	262
9.3	Registers Controlling 8-Bit Timers H0 and H1	266
9.4	Operation of 8-Bit Timers H0 and H1	271
9.4.1	Operation as interval timer/square-wave output	271
9.4.2	Operation as PWM output	274
9.4.3	Carrier generator operation (8-bit timer H1 only).....	280
CHAPTER 10	WATCH TIMER.....	287
10.1	Functions of Watch Timer	287
10.2	Configuration of Watch Timer.....	288
10.3	Register Controlling Watch Timer	289
10.4	Watch Timer Operations.....	291
10.4.1	Watch timer operation	291
10.4.2	Interval timer operation.....	291
10.5	Cautions for Watch Timer	292
CHAPTER 11	WATCHDOG TIMER	293
11.1	Functions of Watchdog Timer	293
11.2	Configuration of Watchdog Timer	294
11.3	Register Controlling Watchdog Timer	295
11.4	Operation of Watchdog Timer.....	296
11.4.1	Controlling operation of watchdog timer	296
11.4.2	Setting overflow time of watchdog timer.....	297
11.4.3	Setting window open period of watchdog timer	298
CHAPTER 12	CLOCK OUTPUT/BUZZER OUTPUT CONTROLLER.....	300
12.1	Functions of Clock Output/Buzzer Output Controller	300
12.2	Configuration of Clock Output/Buzzer Output Controller	301
12.3	Registers Controlling Clock Output/Buzzer Output Controller.....	301
12.4	Operations of Clock Output/Buzzer Output Controller	303
12.4.1	Operation as clock output.....	303
12.4.2	Operation as buzzer output	303
CHAPTER 13	A/D CONVERTER	304
13.1	Function of A/D Converter	304
13.2	Configuration of A/D Converter	305
13.3	Registers Used in A/D Converter.....	307
13.4	A/D Converter Operations	315
13.4.1	Basic operations of A/D converter	315
13.4.2	Input voltage and conversion results	317

13.4.3	A/D converter operation mode	318
13.5	How to Read A/D Converter Characteristics Table	320
13.6	Cautions for A/D Converter.....	322
CHAPTER 14 SERIAL INTERFACE UART0.....		326
14.1	Functions of Serial Interface UART0	326
14.2	Configuration of Serial Interface UART0	327
14.3	Registers Controlling Serial Interface UART0	330
14.4	Operation of Serial Interface UART0.....	335
14.4.1	Operation stop mode.....	335
14.4.2	Asynchronous serial interface (UART) mode	336
14.4.3	Dedicated baud rate generator	342
CHAPTER 15 SERIAL INTERFACE UART6.....		347
15.1	Functions of Serial Interface UART6	347
15.2	Configuration of Serial Interface UART6	351
15.3	Registers Controlling Serial Interface UART6	354
15.4	Operation of Serial Interface UART6.....	363
15.4.1	Operation stop mode.....	363
15.4.2	Asynchronous serial interface (UART) mode	364
15.4.3	Dedicated baud rate generator	377
CHAPTER 16 SERIAL INTERFACES CSI10 AND CSI11.....		384
16.1	Functions of Serial Interfaces CSI10 and CSI11	384
16.2	Configuration of Serial Interfaces CSI10 and CSI11	385
16.3	Registers Controlling Serial Interfaces CSI10 and CSI11	388
16.4	Operation of Serial Interfaces CSI10 and CSI11	393
16.4.1	Operation stop mode.....	393
16.4.2	3-wire serial I/O mode.....	394
CHAPTER 17 SERIAL INTERFACE IIC0		406
17.1	Functions of Serial Interface IIC0.....	406
17.2	Configuration of Serial Interface IIC0	409
17.3	Registers to Control Serial Interface IIC0.....	412
17.4	I²C Bus Mode Functions	425
17.4.1	Pin configuration	425
17.5	I²C Bus Definitions and Control Methods.....	426
17.5.1	Start conditions	426
17.5.2	Addresses	427
17.5.3	Transfer direction specification	427
17.5.4	Acknowledge (\overline{ACK}).....	428
17.5.5	Stop condition	429
17.5.6	Wait.....	430
17.5.7	Canceling wait.....	432
17.5.8	Interrupt request (INTIIC0) generation timing and wait control.....	432
17.5.9	Address match detection method.....	433
17.5.10	Error detection	433

★

17.5.11	Extension code.....	434
17.5.12	Arbitration.....	435
17.5.13	Wakeup function.....	436
17.5.14	Communication reservation.....	437
17.5.15	Other cautions.....	440
17.5.16	Communication operations.....	442
17.5.17	Timing of I ² C interrupt request (INTIIC0) occurrence.....	449
17.6	Timing Charts	470
CHAPTER 18	MULTIPLIER/DIVIDER	
	(μ PD78F0534, 78F0535, 78F0536, 78F0537, AND 78F0537D ONLY)	477
18.1	Functions of Multiplier/Divider	477
18.2	Configuration of Multiplier/Divider	477
18.3	Register Controlling Multiplier/Divider	481
18.4	Operations of Multiplier/Divider.....	482
18.4.1	Multiplication operation.....	482
18.4.2	Division operation.....	484
CHAPTER 19	INTERRUPT FUNCTIONS	486
19.1	Interrupt Function Types.....	486
19.2	Interrupt Sources and Configuration	486
19.3	Registers Controlling Interrupt Functions	491
19.4	Interrupt Servicing Operations	499
19.4.1	Maskable interrupt acknowledgement.....	499
19.4.2	Software interrupt request acknowledgement	501
19.4.3	Multiple interrupt servicing.....	502
19.4.4	Interrupt request hold	505
CHAPTER 20	KEY INTERRUPT FUNCTION	506
20.1	Functions of Key Interrupt	506
20.2	Configuration of Key Interrupt.....	506
20.3	Register Controlling Key Interrupt	507
CHAPTER 21	STANDBY FUNCTION	508
21.1	Standby Function and Configuration.....	508
21.1.1	Standby function.....	508
21.1.2	Registers controlling standby function.....	508
21.2	Standby Function Operation.....	511
21.2.1	HALT mode	511
21.2.2	STOP mode	516
CHAPTER 22	RESET FUNCTION.....	521
22.1	Register for Confirming Reset Source.....	529
CHAPTER 23	POWER-ON-CLEAR CIRCUIT.....	530
23.1	Functions of Power-on-Clear Circuit	530

23.2	Configuration of Power-on-Clear Circuit.....	531
23.3	Operation of Power-on-Clear Circuit	531
23.4	Cautions for Power-on-Clear Circuit.....	534
CHAPTER 24 LOW-VOLTAGE DETECTOR.....		536
24.1	Functions of Low-Voltage Detector	536
24.2	Configuration of Low-Voltage Detector	536
24.3	Registers Controlling Low-Voltage Detector	537
24.4	Operation of Low-Voltage Detector	540
24.4.1	When used as reset	541
24.4.2	When used as interrupt.....	546
24.5	Cautions for Low-Voltage Detector.....	551
CHAPTER 25 OPTION BYTE.....		554
25.1	Functions of Option Bytes	554
25.2	Format of Option Byte	555
CHAPTER 26 FLASH MEMORY.....		558
26.1	Internal Memory Size Switching Register	558
26.2	Internal Expansion RAM Size Switching Register.....	560
26.3	Writing with Flash Programmer	561
26.4	Programming Environment.....	564
26.5	Communication Mode	564
26.6	Handling of Pins on Board.....	566
26.6.1	FLMD0 pin	566
26.6.2	Serial interface pins.....	566
26.6.3	RESET pin	568
26.6.4	Port pins.....	568
26.6.5	REGC pin.....	568
26.6.6	Other signal pins	

28.1.2	Description of operation column	581
28.1.3	Description of flag operation column	581
28.2	Operation List	582
28.3	Instructions Listed by Addressing Type	590
CHAPTER 29 ELECTRICAL SPECIFICATIONS (TARGET).....		593
CHAPTER 30 PACKAGE DRAWINGS		612
CHAPTER 31 CAUTIONS FOR WAIT.....		617
31.1	Cautions for Wait.....	617
31.2	Peripheral Hardware That Generates Wait	618
APPENDIX A DEVELOPMENT TOOLS.....		619
A.1	Software Package	622
A.2	Language Processing Software.....	622
A.3	Control Software	623
A.4	Flash Memory Writing Tools	623
A.5	Debugging Tools (Hardware).....	624
A.5.1	When using in-circuit emulator QB-78K0KX2.....	624
A.5.2	When using on-chip debug emulator QB-78K0MINI.....	625
A.6	Debugging Tools (Software)	625
* APPENDIX B NOTES ON TARGET SYSTEM DESIGN		626
APPENDIX C REGISTER INDEX		628
C.1	Register Index (In Alphabetical Order with Respect to Register Names)	628
C.2	Register Index (In Alphabetical Order with Respect to Register Symbol).....	632
APPENDIX D REVISION HISTORY		636
D.1	Major Revisions in This Edition.....	636
* D.2	Revisions History up to Previous Edition	643

CHAPTER 1 OUTLINE

1.1 Features

- Minimum instruction execution time can be changed from high speed (0.1 μ s: @ 20 MHz operation with high-speed system clock) to ultra low-speed (122 μ s: @ 32.768 kHz operation with subsystem clock)
- General-purpose register: 8 bits \times 32 registers (8 bits \times 8 registers \times 4 banks)
- ROM, RAM capacities

Part Number	Item	Program Memory (ROM)	Data Memory			
			Internal High-Speed RAM ^{Note}	Internal Expansion RAM ^{Note}		
μ PD78F0531		Flash memory ^{Note}	16 KB	768 bytes	–	
μ PD78F0532			24 KB	1 KB		
μ PD78F0533			32 KB			
μ PD78F0534			48 KB			1 KB
μ PD78F0535			60 KB			2 KB
μ PD78F0536			96 KB			4 KB
μ PD78F0537, 78F0537D			128 KB			6 KB

Note The internal flash memory, internal high-speed RAM capacities, and internal expansion RAM capacities can be changed using the internal memory size switching register (IMS) and the internal expansion RAM size switching register (IXS). For IMS and IXS, see **26.1 Memory Size Switching Register** and **26.2 Internal Expansion RAM Size Switching Register**.

- On-chip single-power-supply flash memory
- Self-programming (with boot swap function)
- On-chip debug function (μ PD78F0537D only)^{Note}
- On-chip power-on-clear (POC) circuit and low-voltage detector (LVI)
- On-chip watchdog timer (operable with the on-chip internal low-speed oscillation clock)
- On-chip multiplier/divider (16 bits \times 16 bits, 32 bits / 16 bits)
(μ PD78F0534, 78F0535, 78F0536, 78F0537, 78F0537D only)
- On-chip key interrupt function
- On-chip clock output/buzzer output controller
- I/O ports: 55 (N-ch open drain: 4)

★ **Note** The μ PD78F0537D has an on-chip debug function. Do not use this product for mass production because its reliability cannot be guaranteed after the on-chip debug function has been used, from the viewpoint of the restriction on the number of times the flash memory can be rewritten. NEC Electronics does not accept any complaint about this product.

○ Timer

μ PD78F0531, 78F0532, 78F0533: 7 channels

μ PD78F0534, 78F0535, 78F0536, 78F0537, 78F0537D: 8 channels

- 16-bit timer/event counter: 2 channels^{Note}
- 8-bit timer/event counter: 2 channels
- 8-bit timer: 2 channels
- Watch timer: 1 channel
- Watchdog timer: 1 channel

Note μ PD78F0531, 78F0532, 78F0533: 1 channel

○ Serial interface

μ PD78F0531, 78F0532, 78F0533: 3 channels

μ PD78F0534, 78F0535, 78F0536, 78F0537, 78F0537D: 4 channels

- UART (LIN (Local Interconnect Network)-bus supported): 1 channel
- CSI/UART^{Note1}: 1 channel
- CSI^{Note2}: 1 channel
- I²C: 1 channel

Notes 1. Select either of the functions of these alternate-function pins.

2. μ PD78F0534, 78F0535, 78F0536, 78F0537, 78F0537D only

○ 10-bit resolution A/D converter ($AV_{REF} = 2.3$ to 5.5 V): 8 channels

○ Power supply voltage: $V_{DD} = 1.8$ to 5.5 V

★ ○ Operating ambient temperature:

- $T_A = -40$ to $+85^\circ\text{C}$: (T), (S), (R) products
- $T_A = -40$ to $+125^\circ\text{C}$: (T2) product

1.2 Applications

- ★ ○ Automotive equipment ((A), (A1), (A2) grade products, under development)
 - System control for body electricals (power windows, keyless entry reception, etc.)
 - Sub-microcontrollers for control
- Car audio
- AV equipment, home audio
- PC peripheral equipment (keyboards, etc.)
- Household electrical appliances
 - Air conditioners
 - Microwave ovens, electric rice cookers
- Industrial equipment
 - Pumps
 - Vending machines
 - FA (Factory Automation)

★ 1.3 Ordering Information

● Flash memory version (1/4)

Part Number	Package
μ PD78F0531GB(T)-UEU-A	64-pin plastic LQFP (10x10)
μ PD78F0531GB(T2)-UEU-A	64-pin plastic LQFP (10x10)
μ PD78F0531GB(S)-UEU-A	64-pin plastic LQFP (10x10)
μ PD78F0531GB(R)-UEU-A	64-pin plastic LQFP (10x10)
μ PD78F0531GC(T)-UBS-A	64-pin plastic LQFP (14x14)
μ PD78F0531GC(T2)-UBS-A	64-pin plastic LQFP (14x14)
μ PD78F0531GC(S)-UBS-A	64-pin plastic LQFP (14x14)
μ PD78F0531GC(R)-UBS-A	64-pin plastic LQFP (14x14)
μ PD78F0531GK(T)-UET-A	64-pin plastic LQFP (12x12)
μ PD78F0531GK(T2)-UET-A	64-pin plastic LQFP (12x12)
μ PD78F0531GK(S)-UET-A	64-pin plastic LQFP (12x12)
μ PD78F0531GK(R)-UET-A	64-pin plastic LQFP (12x12)
μ PD78F0531GA(T)-9EV-A	64-pin plastic TQFP (7x7)
μ PD78F0531GA(T2)-9EV-A	64-pin plastic TQFP (7x7)
μ PD78F0531GA(S)-9EV-A	64-pin plastic TQFP (7x7)
μ PD78F0531GA(R)-9EV-A	64-pin plastic TQFP (7x7)
μ PD78F0531FC(T)-AA1-A	64-pin plastic FLGA (5x5)
μ PD78F0531FC(S)-AA1-A	64-pin plastic FLGA (5x5)
μ PD78F0531FC(R)-AA1-A	64-pin plastic FLGA (5x5)
μ PD78F0532GB(T)-UEU-A	64-pin plastic LQFP (10x10)
μ PD78F0532GB(T2)-UEU-A	64-pin plastic LQFP (10x10)
μ PD78F0532GB(S)-UEU-A	64-pin plastic LQFP (10x10)
μ PD78F0532GB(R)-UEU-A	64-pin plastic LQFP (10x10)
μ PD78F0532GC(T)-UBS-A	64-pin plastic LQFP (14x14)
μ PD78F0532GC(T2)-UBS-A	64-pin plastic LQFP (14x14)
μ PD78F0532GC(S)-UBS-A	64-pin plastic LQFP (14x14)
μ PD78F0532GC(R)-UBS-A	64-pin plastic LQFP (14x14)
μ PD78F0532GK(T)-UET-A	64-pin plastic LQFP (12x12)
μ PD78F0532GK(T2)-UET-A	64-pin plastic LQFP (12x12)
μ PD78F0532GK(S)-UET-A	64-pin plastic LQFP (12x12)
μ PD78F0532GK(R)-UET-A	64-pin plastic LQFP (12x12)
μ PD78F0532GA(T)-9EV-A	64-pin plastic TQFP (7x7)
μ PD78F0532GA(T2)-9EV-A	64-pin plastic TQFP (7x7)
μ PD78F0532GA(S)-9EV-A	64-pin plastic TQFP (7x7)
μ PD78F0532GA(R)-9EV-A	64-pin plastic TQFP (7x7)
μ PD78F0532FC(T)-AA1-A	64-pin plastic FLGA (5x5)
μ PD78F0532FC(S)-AA1-A	64-pin plastic FLGA (5x5)
μ PD78F0532FC(R)-AA1-A	64-pin plastic FLGA (5x5)

- Flash memory version (2/4)

Part Number	Package
μ PD78F0533GB(T)-UEU-A	64-pin plastic LQFP (10x10)
μ PD78F0533GB(T2)-UEU-A	64-pin plastic LQFP (10x10)
μ PD78F0533GB(S)-UEU-A	64-pin plastic LQFP (10x10)
μ PD78F0533GB(R)-UEU-A	64-pin plastic LQFP (10x10)
μ PD78F0533GC(T)-UBS-A	64-pin plastic LQFP (14x14)
μ PD78F0533GC(T2)-UBS-A	64-pin plastic LQFP (14x14)
μ PD78F0533GC(S)-UBS-A	64-pin plastic LQFP (14x14)
μ PD78F0533GC(R)-UBS-A	64-pin plastic LQFP (14x14)
μ PD78F0533GK(T)-UET-A	64-pin plastic LQFP (12x12)
μ PD78F0533GK(T2)-UET-A	64-pin plastic LQFP (12x12)
μ PD78F0533GK(S)-UET-A	64-pin plastic LQFP (12x12)
μ PD78F0533GK(R)-UET-A	64-pin plastic LQFP (12x12)
μ PD78F0533GA(T)-9EV-A	64-pin plastic TQFP (7x7)
μ PD78F0533GA(T2)-9EV-A	64-pin plastic TQFP (7x7)
μ PD78F0533GA(S)-9EV-A	64-pin plastic TQFP (7x7)
μ PD78F0533GA(R)-9EV-A	64-pin plastic TQFP (7x7)
μ PD78F0533FC(T)-AA1-A	64-pin plastic FLGA (5x5)
μ PD78F0533FC(S)-AA1-A	64-pin plastic FLGA (5x5)
μ PD78F0533FC(R)-AA1-A	64-pin plastic FLGA (5x5)
μ PD78F0534GB(T)-UEU-A	64-pin plastic LQFP (10x10)
μ PD78F0534GB(T2)-UEU-A	64-pin plastic LQFP (10x10)
μ PD78F0534GB(S)-UEU-A	64-pin plastic LQFP (10x10)
μ PD78F0534GB(R)-UEU-A	64-pin plastic LQFP (10x10)
μ PD78F0534GC(T)-UBS-A	64-pin plastic LQFP (14x14)
μ PD78F0534GC(T2)-UBS-A	64-pin plastic LQFP (14x14)
μ PD78F0534GC(S)-UBS-A	64-pin plastic LQFP (14x14)
μ PD78F0534GC(R)-UBS-A	64-pin plastic LQFP (14x14)
μ PD78F0534GK(T)-UET-A	64-pin plastic LQFP (12x12)
μ PD78F0534GK(T2)-UET-A	64-pin plastic LQFP (12x12)
μ PD78F0534GK(S)-UET-A	64-pin plastic LQFP (12x12)
μ PD78F0534GK(R)-UET-A	64-pin plastic LQFP (12x12)
μ PD78F0534GA(T)-9EV-A	64-pin plastic TQFP (7x7)
μ PD78F0534GA(T2)-9EV-A	64-pin plastic TQFP (7x7)
μ PD78F0534GA(S)-9EV-A	64-pin plastic TQFP (7x7)
μ PD78F0534GA(R)-9EV-A	64-pin plastic TQFP (7x7)
μ PD78F0534FC(T)-AA1-A	64-pin plastic FLGA (5x5)
μ PD78F0534FC(S)-AA1-A	64-pin plastic FLGA (5x5)
μ PD78F0534FC(R)-AA1-A	64-pin plastic FLGA (5x5)

- Flash memory version (3/4)

Part Number	Package
μ PD78F0535GB(T)-UEU-A	64-pin plastic LQFP (10x10)
μ PD78F0535GB(T2)-UEU-A	64-pin plastic LQFP (10x10)
μ PD78F0535GB(S)-UEU-A	64-pin plastic LQFP (10x10)
μ PD78F0535GB(R)-UEU-A	64-pin plastic LQFP (10x10)
μ PD78F0535GC(T)-UBS-A	64-pin plastic LQFP (14x14)
μ PD78F0535GC(T2)-UBS-A	64-pin plastic LQFP (14x14)
μ PD78F0535GC(S)-UBS-A	64-pin plastic LQFP (14x14)
μ PD78F0535GC(R)-UBS-A	64-pin plastic LQFP (14x14)
μ PD78F0535GK(T)-UET-A	64-pin plastic LQFP (12x12)
μ PD78F0535GK(T2)-UET-A	64-pin plastic LQFP (12x12)
μ PD78F0535GK(S)-UET-A	64-pin plastic LQFP (12x12)
μ PD78F0535GK(R)-UET-A	64-pin plastic LQFP (12x12)
μ PD78F0535GA(T)-9EV-A	64-pin plastic TQFP (7x7)
μ PD78F0535GA(T2)-9EV-A	64-pin plastic TQFP (7x7)
μ PD78F0535GA(S)-9EV-A	64-pin plastic TQFP (7x7)
μ PD78F0535GA(R)-9EV-A	64-pin plastic TQFP (7x7)
μ PD78F0535FC(T)-AA1-A	64-pin plastic FLGA (5x5)
μ PD78F0535FC(S)-AA1-A	64-pin plastic FLGA (5x5)
μ PD78F0535FC(R)-AA1-A	64-pin plastic FLGA (5x5)
μ PD78F0536GB(T)-UEU-A	64-pin plastic LQFP (10x10)
μ PD78F0536GB(T2)-UEU-A	64-pin plastic LQFP (10x10)
μ PD78F0536GB(S)-UEU-A	64-pin plastic LQFP (10x10)
μ PD78F0536GB(R)-UEU-A	64-pin plastic LQFP (10x10)
μ PD78F0536GC(T)-UBS-A	64-pin plastic LQFP (14x14)
μ PD78F0536GC(T2)-UBS-A	64-pin plastic LQFP (14x14)
μ PD78F0536GC(S)-UBS-A	64-pin plastic LQFP (14x14)
μ PD78F0536GC(R)-UBS-A	64-pin plastic LQFP (14x14)
μ PD78F0536GK(T)-UET-A	64-pin plastic LQFP (12x12)
μ PD78F0536GK(T2)-UET-A	64-pin plastic LQFP (12x12)
μ PD78F0536GK(S)-UET-A	64-pin plastic LQFP (12x12)
μ PD78F0536GK(R)-UET-A	64-pin plastic LQFP (12x12)
μ PD78F0536GA(T)-9EV-A	64-pin plastic TQFP (7x7)
μ PD78F0536GA(T2)-9EV-A	64-pin plastic TQFP (7x7)
μ PD78F0536GA(S)-9EV-A	64-pin plastic TQFP (7x7)
μ PD78F0536GA(R)-9EV-A	64-pin plastic TQFP (7x7)
μ PD78F0536FC(T)-AA1-A	64-pin plastic FLGA (5x5)
μ PD78F0536FC(S)-AA1-A	64-pin plastic FLGA (5x5)
μ PD78F0536FC(R)-AA1-A	64-pin plastic FLGA (5x5)

- Flash memory version (4/4)

Part Number	Package
μ PD78F0537GB(T)-UEU-A	64-pin plastic LQFP (10x10)
μ PD78F0537GB(T2)-UEU-A	64-pin plastic LQFP (10x10)
μ PD78F0537GB(S)-UEU-A	64-pin plastic LQFP (10x10)
μ PD78F0537GB(R)-UEU-A	64-pin plastic LQFP (10x10)
μ PD78F0537GC(T)-UBS-A	64-pin plastic LQFP (14x14)
μ PD78F0537GC(T2)-UBS-A	64-pin plastic LQFP (14x14)
μ PD78F0537GC(S)-UBS-A	64-pin plastic LQFP (14x14)
μ PD78F0537GC(R)-UBS-A	64-pin plastic LQFP (14x14)
μ PD78F0537GK(T)-UET-A	64-pin plastic LQFP (12x12)
μ PD78F0537GK(T2)-UET-A	64-pin plastic LQFP (12x12)
μ PD78F0537GK(S)-UET-A	64-pin plastic LQFP (12x12)
μ PD78F0537GK(R)-UET-A	64-pin plastic LQFP (12x12)
μ PD78F0537GA(T)-9EV-A	64-pin plastic TQFP (7x7)
μ PD78F0537GA(T2)-9EV-A	64-pin plastic TQFP (7x7)
μ PD78F0537GA(S)-9EV-A	64-pin plastic TQFP (7x7)
μ PD78F0537GA(R)-9EV-A	64-pin plastic TQFP (7x7)
μ PD78F0537FC(T)-AA1-A	64-pin plastic FLGA (5x5)
μ PD78F0537FC(S)-AA1-A	64-pin plastic FLGA (5x5)
μ PD78F0537FC(R)-AA1-A	64-pin plastic FLGA (5x5)
μ PD78F0537DGB(T)-UEU-A ^{Note}	64-pin plastic LQFP (10x10)
μ PD78F0537DGC(T)-UBS-A ^{Note}	64-pin plastic LQFP (14x14)
μ PD78F0537DGK(T)-UET-A ^{Note}	64-pin plastic LQFP (12x12)
μ PD78F0537DGA(T)-9EV-A ^{Note}	64-pin plastic TQFP (7x7)
μ PD78F0537DFC(T)-AA1-A ^{Note}	64-pin plastic FLGA (5x5)

Note The μ PD78F0537D has an on-chip debug function. Do not use this product for mass production, because its reliability cannot be guaranteed after the on-chip debug function has been used, with respect to the number of times the flash memory can be rewritten. NEC Electronics does not accept complaints about this product.

Remark Products with -A at the end of the part number are lead-free products.

The standard quality versions of this product are classified by production process as follows.

(T), (T2): General

(S): Individual contract

(R): For automobile accessories

1.4 Pin Configuration (Top View)

- 64-pin plastic LQFP (10 × 10)
- 64-pin plastic LQFP (14 × 14)
- 64-pin plastic LQFP (12 × 12)
- 64-pin plastic TQFP (7 × 7)

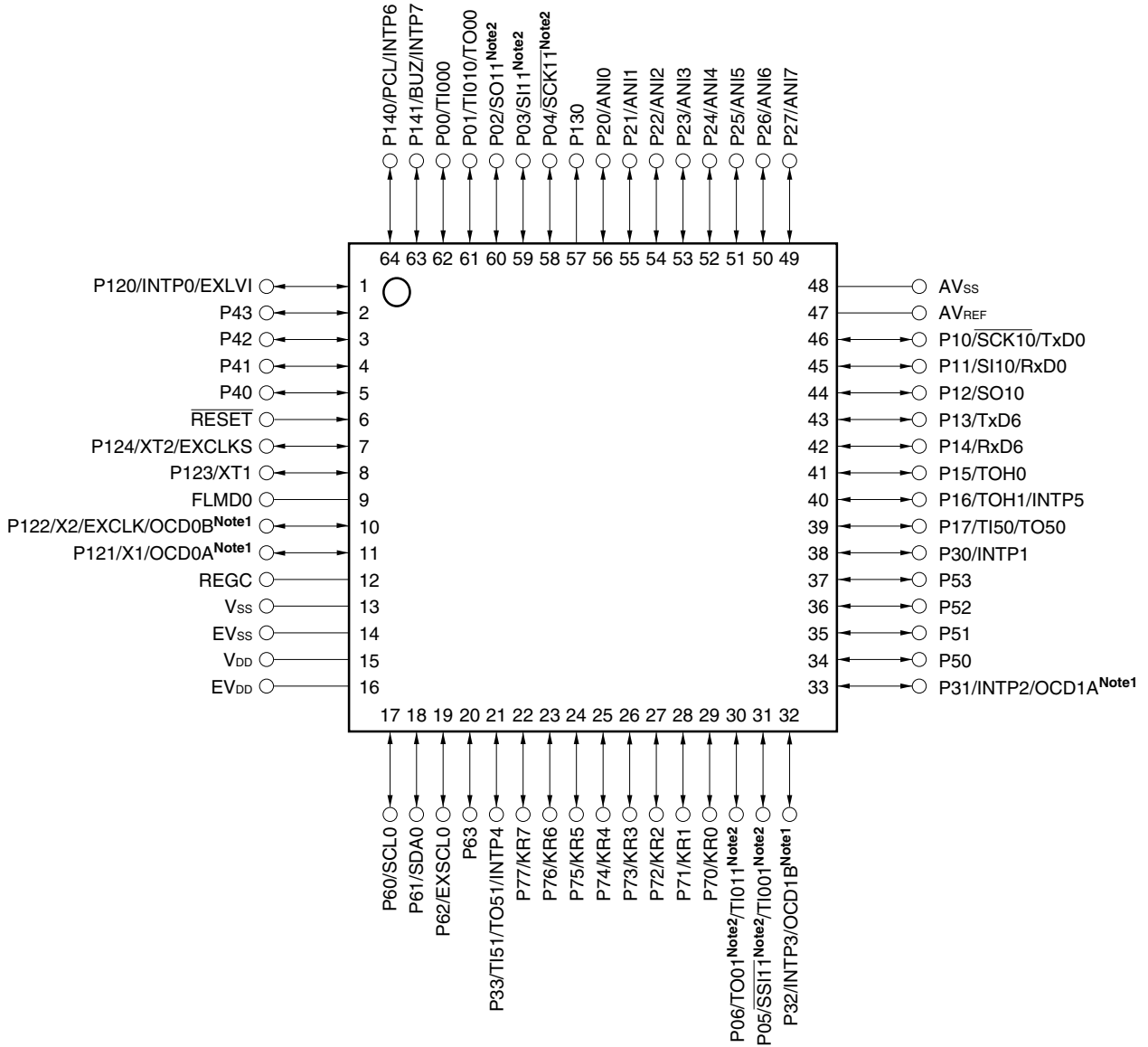

- ★ **Notes 1.** μ PD78F0537D (product with on-chip debug function) only
- 2. μ PD78F0534, 78F0535, 78F0536, 78F0537, 78F0537D only

- ★ **Cautions 1.** Make AV_{ss} the same potential as V_{ss}.
- 2. Connect the REGC pin to V_{ss} via a capacitor (0.47 μ F: target).
- 3. ANI0/P20 to ANI7/P27 are set in the analog input mode after release of reset.

- 64-pin plastic FLGA (5 × 5)

Top View

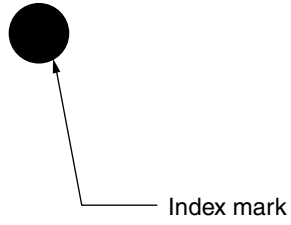

Bottom View

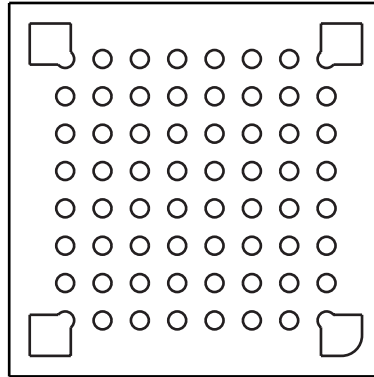

Pin Identification

ANI0 to ANI7:	Analog input	P60 to P63:	Port 6
AV _{REF} :	Analog reference voltage	P70 to P77:	Port 7
AV _{SS} :	Analog ground	P120 to P124:	Port 12
BUZ:	Buzzer output	P130:	Port 13
EV _{DD} :	Power supply for port	P140, P141:	Port 14
EV _{SS} :	Ground for port	PCL:	Programmable clock output
EXCLK:	External clock input (main system clock)	REGC	Regulator capacitance
EXCLKS:	External clock input (subsystem clock)	RESET:	Reset
EXLVI:	External potential input for low-voltage detector	RxD0, RxD6:	Receive data
EXSCL0:	External serial clock input	SCK10, SCK11 ^{Note2} ,	
FLMD0:	Flash programming mode	SCL0:	Serial clock input/output
INTP0 to INTP7:	External interrupt input	SDA0:	Serial data input/output
KR0 to KR7:	Key return	SI10, SI11 ^{Note2} :	Serial data input
OCD0A ^{Note1} ,		SO10, SO11 ^{Note2} :	Serial data output
OCD0B ^{Note1} ,		SSI11 ^{Note2} :	Serial interface chip select input
OCD1A ^{Note1} ,		TI000, TI010,	
OCD1B ^{Note1} :	On chip debug input/output	TI001 ^{Note2} , TI011 ^{Note2} ,	
P00 to P06:	Port 0	TI50, TI51:	Timer input
P10 to P17:	Port 1	TO00, TO01 ^{Note2} ,	
P20 to P27:	Port 2	TO50, TO51,	Timer output
P30 to P33:	Port 3	TOH0, TOH1:	
P40 to P43:	Port 4	TxD0, TxD6:	Transmit data
P50 to P53:	Port 5	V _{DD} :	Power supply
		V _{SS} :	Ground
		X1, X2:	Crystal oscillator (main system clock)
		XT1, XT2:	Crystal oscillator (subsystem clock)

- ★ **Notes 1.** μ PD78F0537D (product with on-chip debug function) only
2. μ PD78F0534, 78F0535, 78F0536, 78F0537, 78F0537D only

1.5 78K0/Kx2 Series Lineup

ROM	RAM	78K0/KB2	78K0/KC2		78K0/KD2	78K0/KE2	78K0/KF2
		30 Pins	44 Pins	48 Pins	52 Pins	64 Pins	80 Pins
128 KB	7 KB	–	–	–	μ PD78F0527D ^{Note}	μ PD78F0537D ^{Note}	μ PD78F0547D ^{Note}
					μ PD78F0527	μ PD78F0537	μ PD78F0547
96 KB	5 KB	–	–	–	μ PD78F0526	μ PD78F0536	μ PD78F0546
60 KB	3 KB	–	–	μ PD78F0515D ^{Note}	μ PD78F0525	μ PD78F0535	μ PD78F0545
				μ PD78F0515			
48 KB	2 KB	–	–	μ PD78F0514	μ PD78F0524	μ PD78F0534	μ PD78F0544
32 KB	1 KB	μ PD78F0503D ^{Note}	μ PD78F0513D ^{Note}	μ PD78F0513	μ PD78F0523	μ PD78F0533	–
		μ PD78F0503	μ PD78F0513				
24 KB	1 KB	μ PD78F0502	μ PD78F0512		μ PD78F0522	μ PD78F0532	–
16 KB	768 B	μ PD78F0501	μ PD78F0511		μ PD78F0521	μ PD78F0531	–
8 KB	512 B	μ PD78F0500	–		–	–	–

Note Product with on-chip debug function

The list of functions in the 78K0/Kx2 Series is shown below.

(1/2)

Part Number		78K0/KB2				78K0/KC2									
		30/36 Pins				44 Pins			48 Pins						
Flash memory (KB)		8	16	24	32	16	24	32	16	24	32	48	60		
RAM (KB)		0.5	0.75	1	1	0.75	1	1	0.75	1	1	2	3		
Bank (flash memory)		-													
Power supply voltage		V _{DD} = 1.8 to 5.5 V													
Regulator		Provided													
Minimum instruction execution time		0.1 μs (20 MHz: V _{DD} = 4.0 to 5.5 V)/0.2 μs (10 MHz: V _{DD} = 2.7 to 5.5 V)/0.4 μs (5 MHz: V _{DD} = 1.8 to 5.5 V)													
★	Clock	Main	High-speed system 20 MHz: V _{DD} = 4.0 to 5.5 V/10 MHz: V _{DD} = 2.7 to 5.5 V/5 MHz: V _{DD} = 1.8 to 5.5 V												
			Internal high-speed oscillation 8 MHz (TYP.): V _{DD} = 1.8 to 5.5 V												
		Subsystem					-								
		Internal low-speed oscillation					240 kHz (TYP.): V _{DD} = 1.8 to 5.5 V								
Port	Total		23				37			41					
	N-ch O.D. (6 V tolerance)		2				4			4					
Timer	16 bits (TM0)		1 ch												
	8 bits (TM5)		2 ch												
	8 bits (TMH)		2 ch												
	Watch		-					1 ch							
	WDT		1 ch												
Serial interface	3-wire CSI		-												
	Automatic transmit/receive 3-wire CSI		-												
	UART/3-wire CSI ^{Note}		1 ch												
	UART supporting LIN-bus		1 ch												
	I ² C bus		1 ch												
10-bit A/D		4 ch				8 ch									
Interrupt	External		6				7			8					
	Internal		14				16								
Key interrupt		-				4 ch									
★	Reset	RESET pin		Provided											
		POC		1.59 V ±0.15 V (rise time to 1.8 V: 3.6 ms (MAX.))											
		LVI		The detection level of the supply voltage is selectable in 16 steps.											
		WDT		Provided											
Clock output/buzzer output		-					Clock output only								
Multiplier/divider		-					Provided								
On-chip debug function		μPD78F0503D only				μPD78F0513D only			μPD78F0515D only						
★		Operating ambient temperature -40 to +85°C ((T), (R), (S) products), -40 to +125°C ((T2) product)													

Note Select either of the functions of these alternate-function pins.

Part Number		78K0/KD2						78K0/KE2						78K0/KF2					
		52 Pins						64 Pins						80 Pins					
Flash memory (KB)		16	24	32	48	60	96	128	16	24	32	48	60	96	128	48	60	96	128
RAM (KB)		0.75	1	1	2	3	5	7	0.75	1	1	2	3	5	7	2	3	5	7
Bank (flash memory)		-						4	6	-						4	6		
Power supply voltage		V _{DD} = 1.8 to 5.5 V																	
Regulator		Provided																	
Minimum instruction execution time		0.1 μs (20 MHz: V _{DD} = 4.0 to 5.5 V)/0.2 μs (10 MHz: V _{DD} = 2.7 to 5.5 V)/ 0.4 μs (5 MHz: V _{DD} = 1.8 to 5.5 V)																	
★	Clock	Main	High-speed system		20 MHz: V _{DD} = 4.0 to 5.5 V/10 MHz: V _{DD} = 2.7 to 5.5 V/5 MHz: V _{DD} = 1.8 to 5.5 V														
			Internal high-speed oscillation		8 MHz (TYP.): V _{DD} = 1.8 to 5.5 V														
		Subsystem		32.768 kHz (TYP.): V _{DD} = 1.8 to 5.5 V															
		Internal low-speed oscillation		240 kHz (TYP.): V _{DD} = 1.8 to 5.5 V															
★	Port	Total		45						55						71			
		N-ch O.D. (6 V tolerance)		4						4						4			
★	Timer	16 bits (TM0)		1 ch						2 ch									
		8 bits (TM5)		2 ch															
		8 bits (TMH)		2 ch															
		Watch		1 ch															
		WDT		1 ch															
★	Serial interface	3-wire CSI		-						1 ch									
		Automatic transmit/receive 3-wire CSI		-						1 ch									
		UART/3-wire CSI ^{Note}		1 ch															
		UART supporting LIN-bus		1 ch															
		I ² C bus		1 ch															
10-bit A/D		8 ch																	
★	Interrupt	External		8						9									
		Internal		16						19				20					
Key interrupt		8 ch																	
★	Reset	RESET pin		Provided															
		POC		1.59 V ±0.15 V (rise time to 1.8 V: 3.6 ms (MAX.))															
		LVI		The detection level of the supply voltage is selectable in 16 steps.															
		WDT		Provided															
Clock output/buzzer output		Clock output only						Provided											
Multiplier/divider		-		Provided				-		Provided									
On-chip debug function		μPD78F0527D only						μPD78F0537D only						μPD78F0547D only					
★ Operating ambient temperature		-40 to +85°C ((T), (R), (S) products), -40 to +125°C ((T2) product)																	

Note Select either of the functions of these alternate-function pins.

1.6 Block Diagram

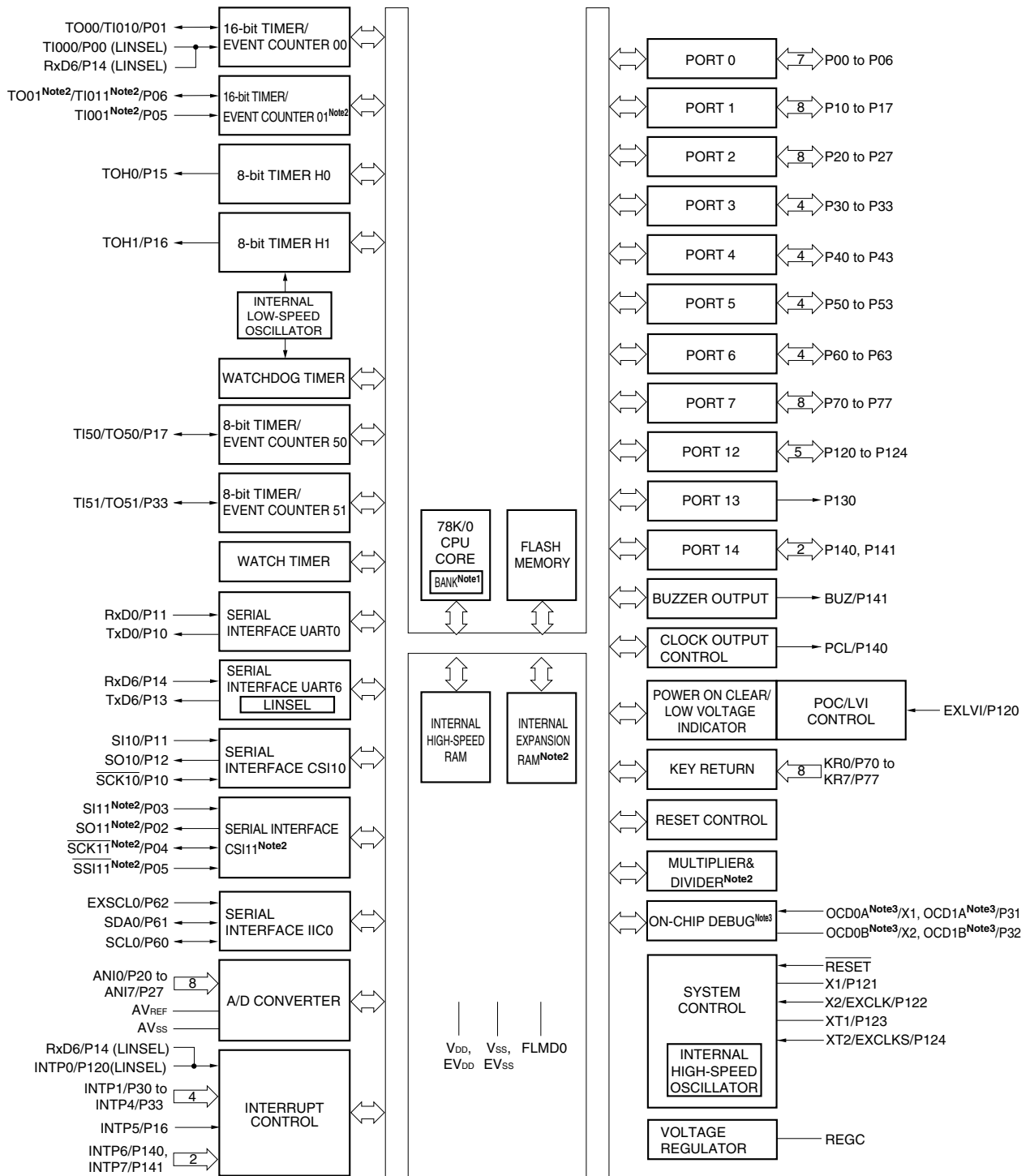

- ★
- Notes**
1. Available only in the μ PD78F0536, 78F0537, and 78F0537D.
 2. Available only in the μ PD78F0534, 78F0535, 78F0536, 78F0537, and 78F0537D.
 3. Available only in the μ PD78F0537D.

1.7 Outline of Functions

(1/2)

Item		μPD78F0531	μPD78F0532	μPD78F0533	μPD78F0534	μPD78F0535	μPD78F0536	μPD78F0537	μPD78F0537D	
Internal memory (bytes)	Flash memory (self-programming supported) ^{Note 1}	16 K	24 K	32 K	48 K	60 K	96 K	128 K		
	Memory bank ^{Note 2}	–					4	6		
	High-speed RAM ^{Note 1}	768	1 K							
	Expansion RAM ^{Note 1}	–			1 K	2 K	4 K	6 K		
Memory space		64 KB								
★ Main system clock (oscillation frequency)	High-speed system clock	X1 (crystal/ceramic) oscillation, external main system clock input (EXCLK) 1 to 20 MHz: V _{DD} = 4.0 to 5.5 V, 1 to 10 MHz: V _{DD} = 2.7 to 5.5 V, 1 to 5 MHz: V _{DD} = 1.8 to 5.5 V								
	Internal high-speed oscillation clock	Internal oscillation 8 MHz (TYP.): V _{DD} = 1.8 to 5.5 V								
Subsystem clock (oscillation frequency)		XT1 (crystal) oscillation, external subsystem clock input (EXCLKS) 32.768 kHz (TYP.): V _{DD} = 1.8 to 5.5 V								
★ Internal low-speed oscillation clock (for TMH1, WDT)	Internal oscillation 240 kHz (TYP.): V _{DD} = 1.8 to 5.5 V									
General-purpose registers		8 bits × 32 registers (8 bits × 8 registers × 4 banks)								
Minimum instruction execution time		0.1 μs (high-speed system clock: @ f _{XH} = 20 MHz operation)								
		0.25 μs (TYP.) (internal high-speed oscillation clock: @ f _{RH} = 8 MHz (TYP.) operation)								
		122 μs (subsystem clock: @ f _{SUB} = 32.768 kHz operation)								
Instruction set		<ul style="list-style-type: none"> • 8-bit operation, 16-bit operation • Multiply/divide (8 bits × 8 bits, 16 bits ÷ 8 bits) • Bit manipulate (set, reset, test, and Boolean operation) • BCD adjust, etc. 								
I/O ports		Total: 55 CMOS I/O: 50 CMOS output: 1 N-ch open-drain I/O (6 V tolerance): 4								
Timers		<ul style="list-style-type: none"> • 16-bit timer/event counter: 1 channel • 8-bit timer/event counter: 2 channels • 8-bit timer: 2 channels • Watch timer: 1 channel • Watchdog timer: 1 channel 				<ul style="list-style-type: none"> • 16-bit timer/event counter: 2 channels • 8-bit timer/event counter: 2 channels • 8-bit timer: 2 channels • Watch timer: 1 channel • Watchdog timer: 1 channel 				
	Timer outputs	5 (PWM output: 4, PPG output: 1)				6 (PWM output: 4, PPG output: 2)				
Clock output		<ul style="list-style-type: none"> • 156.25 kHz, 312.5 kHz, 625 kHz, 1.25 MHz, 2.5 MHz, 5 MHz, 10 MHz (peripheral hardware clock: @ f_{PRS} = 20 MHz operation) • 32.768 kHz (subsystem clock: @ f_{SUB} = 32.768 kHz operation) 								
Buzzer output		2.44 kHz, 4.88 kHz, 9.77 kHz, 19.54 kHz (peripheral hardware clock: @ f _{PRS} = 20 MHz operation)								
A/D converter		10-bit resolution × 8 channels (AV _{REF} = 2.3 to 5.5 V)								

Notes 1. The internal flash memory capacity, internal high-speed RAM capacity, and internal expansion RAM capacity can be changed using the internal memory size switching register (IMS) and the internal expansion RAM size switching register (IXS).

2. Banks to be used can be changed using the bank select register (BANK).

Item		μPD78F0531	μPD78F0532	μPD78F0533	μPD78F0534	μPD78F0535	μPD78F0536	μPD78F0537	μPD78F0537D
Serial interface		<ul style="list-style-type: none"> • UART mode supporting LIN-bus: 1 channel • 3-wire serial I/O mode/UART mode^{Note}: 1 channel • I²C bus mode: 1 channel 			<ul style="list-style-type: none"> • UART mode supporting LIN-bus: 1 channel • 3-wire serial I/O mode/UART mode^{Note}: 1 channel • 3-wire serial I/O mode: 1 channel • I²C bus mode: 1 channel 				
Multiplier/divider		-			<ul style="list-style-type: none"> • 16 bits × 16 bits = 32 bits (multiplication) • 32 bits ÷ 16 bits = 32 bits remainder of 16 bits (division) 				
Vectored interrupt sources	Internal	16			19				
	External	9							
Key interrupt		Key interrupt (INTKR) occurs by detecting falling edge of key input pins (KR0 to KR7).							
Reset		<ul style="list-style-type: none"> • Reset using $\overline{\text{RESET}}$ pin • Internal reset by watchdog timer • Internal reset by power-on-clear • Internal reset by low-voltage detector 							
On-chip debug function		-							Provided
Power supply voltage		V _{DD} = 1.8 to 5.5 V							
Operating ambient temperature		<ul style="list-style-type: none"> • T_A = -40 to +85°C ((T), (R), (S) products) • T_A = -40 to +125°C ((T2) product) 							
Package		<ul style="list-style-type: none"> • 64-pin plastic LQFP (10 × 10) • 64-pin plastic LQFP (14 × 14) • 64-pin plastic LQFP (12 × 12) • 64-pin plastic TQFP (7 × 7) • 64-pin plastic FLGA (5 × 5) 							

Note Select either of the functions of these alternate-function pins.

Caution The operating voltage range may be changed after evaluation of the device.

An outline of the timer is shown below.

		16-Bit Timer/ Event Counters 00 and 01 ^{Note 1}		8-Bit Timer/ Event Counters 50 and 51		8-Bit Timers H0 and H1		Watch Timer	Watchdog Timer
		TM00	TM01 ^{Note 1}	TM50	TM51	TMH0	TMH1		
Function	Interval timer	1 channel	1 channel	1 channel	1 channel	1 channel	1 channel	1 channel ^{Note 2}	-
	External event counter	1 channel	1 channel	1 channel	1 channel	-	-	-	-
	PPG output	1 output	1 output	-	-	-	-	-	-
	PWM output	-	-	1 output	1 output	1 output	1 output	-	-
	Pulse width measurement	2 inputs	2 inputs	-	-	-	-	-	-
	Square-wave output	1 output	1 output	1 output	1 output	1 output	1 output	-	-
	Carrier generator	-	-	-	-	-	1 output ^{Note 3}	-	-
	Watch Timer	-	-	-	-	-	-	1 channel ^{Note 2}	-
	Watchdog timer	-	-	-	-	-	-	-	1 channel
Interrupt source		2	2	1	1	1	1	1	-

Notes 1. Available only in the μPD78F0534, 78F0535, 78F0536, 78F0537, and 78F0537D.

2. In the watch timer, the watch timer function and interval timer function can be used simultaneously.

3. TM51 and TMH1 can be used in combination as a carrier generator mode.

CHAPTER 2 PIN FUNCTIONS

2.1 Pin Function List

There are three types of pin I/O buffer power supplies: AV_{REF} , EV_{DD} , and V_{DD} . The relationship between these power supplies and the pins is shown below.

★

Table 2-1. Pin I/O Buffer Power Supplies

Power Supply	Corresponding Pins
AV_{REF}	P20 to P27
EV_{DD}	Port pins other than P20 to P27 and P121 to P124
V_{DD}	<ul style="list-style-type: none"> • P121 to P124 • Pins other than port

(1) Port functions (1/2)

Function Name	I/O	Function	After Reset	Alternate Function
P00	I/O	Port 0. 7-bit I/O port. Input/output can be specified in 1-bit units. Use of an on-chip pull-up resistor can be specified by a software setting.	Input port	TI000
P01				TI010/TO00
P02				SO11 ^{Note1}
P03				SI11 ^{Note1}
P04				SCK11 ^{Note1}
P05				TI001 ^{Note1} / SS11 ^{Note1}
P06				TI011 ^{Note1} / TO01 ^{Note1}
P10	I/O	Port 1. 8-bit I/O port. Input/output can be specified in 1-bit units. Use of an on-chip pull-up resistor can be specified by a software setting.	Input port	SCK10/TxD0
P11				SI10/RxD0
P12				SO10
P13				TxD6
P14				RxD6
P15				TOH0
P16				TOH1/INTP5
P17				TI50/TO50
P20 to P27	I/O	Port 2. 8-bit I/O port. Input/output can be specified in 1-bit units.	Analog input	ANI0 to ANI7
P30	I/O	Port 3. 4-bit I/O port. Input/output can be specified in 1-bit units. Use of an on-chip pull-up resistor can be specified by a software setting.	Input port	INTP1
P31				INTP2/OCD1A ^{Note2}
P32				INTP3/OCD1B ^{Note2}
P33				TI51/TO51/INTP4

Notes 1. Available only in the μ PD78F0534, 78F0535, 78F0536, 78F0537, and 78F0537D.

★

2. μ PD78F0537D only

(1) Port functions (2/2)

Function Name	I/O	Function	After Reset	Alternate Function
P40 to P43	I/O	Port 4. 4-bit I/O port. Input/output can be specified in 1-bit units. Use of an on-chip pull-up resistor can be specified by a software setting.	Input port	–
P50 to P53	I/O	Port 5. 4-bit I/O port. Input/output can be specified in 1-bit units. Use of an on-chip pull-up resistor can be specified by a software setting.	Input port	–
P60	I/O	Port 6. 4-bit I/O port. Output of P60 to P63 is N-ch open-drain output (6 V tolerance). Input/output can be specified in 1-bit units.	Input port	SCL0
P61				SDA0
P62				EXSCL0
P63				–
P70 to P77	I/O	Port 7. 8-bit I/O port. Input/output can be specified in 1-bit units. Use of an on-chip pull-up resistor can be specified by a software setting.	Input port	KR0 to KR7
P120	I/O	Port 12. 5-bit I/O port. Input/output can be specified in 1-bit units. Only for P120, use of an on-chip pull-up resistor can be specified by a software setting.	Input port	INTP0/EXLVI
P121				X1/OCD0A ^{Note}
P122				X2/EXCLK/OCD0B ^{Note}
P123				XT1
P124				XT2/EXCLKS
P130	Output	Port 13. 1-bit output-only port.	Output port	–
P140	I/O	Port 14. 2-bit I/O port. Input/output can be specified in 1-bit units. Use of an on-chip pull-up resistor can be specified by a software setting.	Input port	PCL/INTP6
P141				BUZ/INTP7

★ **Note** μ PD78F0537D only

(2) Non-port functions (1/2)

Function Name	I/O	Function	After Reset	Alternate Function
INTP0	Input	External interrupt request input for which the valid edge (rising edge, falling edge, or both rising and falling edges) can be specified	Input port	P120/EXLVI
INTP1				P30
INTP2				P31/OCD1A ^{Note2}
INTP3				P32/OCD1B ^{Note2}
INTP4				P33/TI51/TO51
INTP5				P16/TOH1
INTP6				P140/PCL
INTP7				P141/BUZ
SI10	Input	Serial data input to serial interface	Input port	P11/RxD0
SI11 ^{Note1}				P03
SO10	Output	Serial data output from serial interface	Input port	P12
SO11 ^{Note1}				P02
SDA0	I/O	Serial data I/O for serial interface	Input port	P61
SCK10	I/O	Clock input/output for serial interface	Input port	P10/TxD0
SCK11 ^{Note1}				P04
SCL0				P60
EXSCL0	Input	External clock input for serial interface. To input an external clock, input a clock of 6.4 MHz.	Input port	P62
SSI11 ^{Note1}	Input	Chip select input for serial interface	Input port	P05/TI001
RxD0	Input	Serial data input to asynchronous serial interface	Input port	P11/SI10
RxD6				P14
TxD0	Output	Serial data output from asynchronous serial interface	Input port	P10/SCK10
TxD6				P13
TI000	Input	External count clock input to 16-bit timer/event counter 00 Capture trigger input to capture registers (CR000, CR010) of 16-bit timer/event counter 00	Input port	P00
TI001 ^{Note1}		External count clock input to 16-bit timer/event counter 01 Capture trigger input to capture registers (CR001, CR011) of 16-bit timer/event counter 01		P05/SSI11 ^{Note1}
TI010		Capture trigger input to capture register (CR000) of 16-bit timer/event counter 00		P01/TO00
TI011 ^{Note1}		Capture trigger input to capture register (CR001) of 16-bit timer/event counter 01		P06/TO01 ^{Note}
TO00	Output	16-bit timer/event counter 00 output	Input port	P01/TI010
TO01 ^{Note1}		16-bit timer/event counter 01 output		P06/TI011 ^{Note1}
TI50	Input	External count clock input to 8-bit timer/event counter 50	Input port	P17/TO50
TI51		External count clock input to 8-bit timer/event counter 51		P33/TO51/INTP4

Notes 1. μ PD78F0534, 78F0535, 78F0536, 78F0537, and 78F0537D only

★ 2. μ PD78F0537D only

(2) Non-port pins (2/2)

Function Name	I/O	Function	After Reset	Alternate Function
TO50	Output	8-bit timer/event counter 50 output	Input port	P17/TI50
TO51		8-bit timer/event counter 51 output		P33/TI51/INTP4
TOH0		8-bit timer H0 output		P15
TOH1		8-bit timer H1 output		P16/INTP5
PCL	Output	Clock output (for trimming of high-speed system clock, subsystem clock)	Input port	P140/INTP6
BUZ	Output	Buzzer output	Input port	P141/INTP7
ANI0 to ANI7	Input	A/D converter analog input	Analog input	P20 to P27
AV _{REF}	Input	A/D converter reference voltage input and positive power supply for P20 to P27 and A/D converter	–	–
AV _{SS}	–	A/D converter ground potential. Make the same potential as EV _{SS} or V _{SS} .	–	–
KR0 to KR7	Input	Key interrupt input	Input port	P70 to P77
REGC	–	Connecting regulator output (2.5 V) stabilization capacitance for internal operation. Connect to V _{SS} via a capacitor (0.47 μ F: target).	–	–
$\overline{\text{RESET}}$	Input	System reset input	–	–
EXLVI	Input	Potential input for external low-voltage detection	Input port	P120/INTP0
X1	Input	Connecting resonator for main system clock	Input port	P121/OCD0A ^{Note}
X2				–
EXCLK	Input	External clock input for main system clock	Input port	P122/X2/ OCD0B ^{Note}
XT1	Input	Connecting resonator for subsystem clock	Input port	P123
XT2	–		Input port	P124/EXCLKS
EXCLKS	Input	External clock input for subsystem clock	Input port	P124/XT2
V _{DD}	–	Positive power supply (P121 to P124 and except for ports)	–	–
EV _{DD}	–	Positive power supply for ports (except for P20 to P27 and P121 to P124)	–	–
V _{SS}	–	Ground potential (P121 to P124 and except for ports)	–	–
EV _{SS}	–	Ground potential for ports (except for P20 to P27 and P121 to P124)	–	–
FLMD0	–	Flash memory programming mode setting	–	–
OCD0A ^{Note}	Input	Connection for on-chip debug mode setting pins (μ PD78F0537D only)	Input port	P121/X1
OCD1A ^{Note}				P31/INTP2
OCD0B ^{Note}	–			P122/X2/EXCLK
OCD1B ^{Note}	–			P32/INTP3

★ **Note** μ PD78F0537D only

2.2 Description of Pin Functions

2.2.1 P00 to P06 (port 0)

P00 to P06 function as a 7-bit I/O port. These pins also function as timer I/O, serial interface data I/O, clock I/O, and chip select input.

The following operation modes can be specified in 1-bit units.

(1) Port mode

P00 to P06 function as a 7-bit I/O port. P00 to P06 can be set to input or output port in 1-bit units using port mode register 0 (PM0). Use of an on-chip pull-up resistor can be specified by pull-up resistor option register 0 (PU0).

(2) Control mode

P00 to P06 function as timer I/O, serial interface data I/O, clock I/O, and chip select input.

(a) TI000, TI001^{Note}

These are the pins for inputting an external count clock to 16-bit timer/event counters 00 and 01 and are also for inputting a capture trigger signal to the capture registers (CR000, CR010 or CR001, CR011) of 16-bit timer/event counters 00 and 01.

(b) TI010, TI011^{Note}

These are the pins for inputting a capture trigger signal to the capture register (CR000 or CR001) of 16-bit timer/event counters 00 and 01.

(c) TO00, TO01^{Note}

These are timer output pins of 16-bit timer/event counters 00 and 01.

(d) SI11^{Note}

This is a serial data input pin of serial interface CSI11.

(e) SO11^{Note}

This is a serial data output pin of serial interface CSI11.

(f) $\overline{\text{SCK11}}$ ^{Note}

This is a serial clock I/O pin of serial interface CSI11.

(g) $\overline{\text{SSI11}}$ ^{Note}

This is a chip select input pin of serial interface CSI11.

Note μ PD78F0534, 78F0535, 78F0536, 78F0537, and 78F0537D only

2.2.2 P10 to P17 (port 1)

P10 to P17 function as an 8-bit I/O port. These pins also function as pins for external interrupt request input, serial interface data I/O, clock I/O, and timer I/O.

The following operation modes can be specified in 1-bit units.

(1) Port mode

P10 to P17 function as an 8-bit I/O port. P10 to P17 can be set to input or output port in 1-bit units using port mode register 1 (PM1). Use of an on-chip pull-up resistor can be specified by pull-up resistor option register 1 (PU1).

(2) Control mode

P10 to P17 function as external interrupt request input, serial interface data I/O, clock I/O, and timer I/O.

(a) SI10

This is a serial data input pin of serial interface CSI10.

(b) SO10

This is a serial data output pin of serial interface CSI10.

(c) $\overline{\text{SCK10}}$

This is a serial clock I/O pin of serial interface CSI10.

(d) RxD0

This is a serial data input pin of serial interface UART0.

(e) RxD6

This is a serial data input pin of serial interface UART6.

(f) TxD0

This is a serial data output pin of serial interface UART0.

(g) TxD6

This is a serial data output pin of serial interface UART6.

(h) TI50

This is the pin for inputting an external count clock to 8-bit timer/event counter 50.

(i) TO50

This is a timer output pin of 8-bit timer/event counter 50.

(j) TOH0, TOH1

These are the timer output pins of 8-bit timers H0 and H1.

(k) INT5

This is an external interrupt request input pin for which the valid edge (rising edge, falling edge, or both rising and falling edges) can be specified.

2.2.3 P20 to P27 (port 2)

P20 to P27 function as an 8-bit I/O port. These pins also function as pins for A/D converter analog input.

The following operation modes can be specified in 1-bit units.

(1) Port mode

P20 to P27 function as an 8-bit I/O port. P20 to P27 can be set to input or output port in 1-bit units using port mode register 2 (PM2).

(2) Control mode

P20 to P27 function as A/D converter analog input pins (ANI0 to ANI7). When using these pins as analog input pins, see (5) ANI0/P20 to ANI7/P27 in 13.6 Cautions for A/D Converter.

Caution ANI0/P20 to ANI7/P27 are set in the analog input mode after release of reset.

2.2.4 P30 to P33 (port 3)

P30 to P33 function as a 4-bit I/O port. These pins also function as pins for external interrupt request input and timer I/O.

The following operation modes can be specified in 1-bit units.

(1) Port mode

P30 to P33 function as a 4-bit I/O port. P30 to P33 can be set to input or output port in 1-bit units using port mode register 3 (PM3). Use of an on-chip pull-up resistor can be specified by pull-up resistor option register 3 (PU3).

(2) Control mode

P30 to P33 function as external interrupt request input and timer I/O.

(a) INTP1 to INTP4

These are the external interrupt request input pins for which the valid edge (rising edge, falling edge, or both rising and falling edges) can be specified.

(b) TI51

This is an external count clock input pin to 8-bit timer/event counter 51.

(c) TO51

This is a timer output pin from 8-bit timer/event counter 51.

Caution In the μ PD78F0537D, be sure to pull the P31 pin down before a reset release to prevent malfunction.

Remark Only for the μ PD78F0537D, P31 and P32 can be used as on-chip debug mode setting pins (OCD1A, OCD1B) when the on-chip debug function is used. For how to connect an in-circuit emulator supporting on-chip debugging (QB-78K0MINI), see CHAPTER 27 ON-CHIP DEBUG FUNCTION (μ PD78F0537D ONLY).

2.2.5 P40 to P43 (port 4)

P40 to P43 function as a 4-bit I/O port. P40 to P43 can be set to input or output port in 1-bit units using port mode register 4 (PM4). Use of an on-chip pull-up resistor can be specified by pull-up resistor option register 4 (PU4).

2.2.6 P50 to P53 (port 5)

P50 to P53 function as a 4-bit I/O port. P50 to P53 can be set to input or output port in 1-bit units using port mode register 5 (PM5). Use of an on-chip pull-up resistor can be specified by pull-up resistor option register 5 (PU5).

2.2.7 P60 to P63 (port 6)

P60 to P63 function as a 4-bit I/O port. These pins also function as pins for serial interface data I/O, clock I/O, and external clock input.

The following operation modes can be specified in 1-bit units.

(1) Port mode

P60 to P63 function as a 4-bit I/O port. P60 to P63 can be set to input port or output port in 1-bit units using port mode register 6 (PM6).

Output of P60 to P63 is N-ch open-drain output (6 V tolerance).

(2) Control mode

P60 to P63 function as serial interface data I/O, clock I/O, and external clock input.

(a) SDA0

This is a serial data I/O pin for serial interface IIC0.

(b) SCL0

This is a serial clock I/O pin for serial interface IIC0.

(c) EXSCL0

This is an external clock input pin to serial interface IIC0. To input an external clock, input a clock of 6.4 MHz.

2.2.8 P70 to P77 (port 7)

P70 to P77 function as an 8-bit I/O port. These pins also function as key interrupt input pins.

The following operation modes can be specified in 1-bit units.

(1) Port mode

P70 to P77 function as an 8-bit I/O port. P70 to P77 can be set to input or output port in 1-bit units using port mode register 7 (PM7). Use of an on-chip pull-up resistor can be specified by pull-up resistor option register 7 (PU7).

(2) Control mode

P70 to P77 function as key interrupt input pins.

(a) KR0 to KR7

These are the key interrupt input pins

2.2.9 P120 to P124 (port 12)

P120 to P124 function as a 5-bit I/O port. These pins also function as pins for external interrupt request input, potential input for external low-voltage detection, connecting resonator for main system clock, connecting resonator for subsystem clock, external clock input for main system clock, and external clock input for subsystem clock. The following operation modes can be specified in 1-bit units.

(1) Port mode

P120 to P124 function as a 5-bit I/O port. P120 to P124 can be set to input or output port using port mode register 12 (PM12). Only for P120, use of an on-chip pull-up resistor can be specified by pull-up resistor option register 12 (PU12).

(2) Control mode

P120 to P124 function as pins for external interrupt request input, potential input for external low-voltage detection, connecting resonator for main system clock, connecting resonator for subsystem clock, external clock input for main system clock, and external clock input for subsystem clock.

(a) INTPO

This functions as an external interrupt request input (INTPO) for which the valid edge (rising edge, falling edge, or both rising and falling edges) can be specified.

(b) EXLVI

This is a potential input pin for external low-voltage detection.

(c) X1, X2

These are the pins for connecting a resonator for main system clock.

(d) EXCLK

This is an external clock input pin for main system clock.

(e) XT1, XT2

These are the pins for connecting a resonator for subsystem clock.

(f) EXCLKS

This is an external clock input pin for subsystem clock.

Remark Only for the μ PD78F0537D, X1 and X2 can be used as on-chip debug mode setting pins (OCD0A, OCD0B) when the on-chip debug function is used. For how to connect an in-circuit emulator supporting on-chip debugging (QB-78K0MINI), see **CHAPTER 27 ON-CHIP DEBUG FUNCTION (μ PD78F0537D ONLY)**.

2.2.10 P130 (port 13)

P130 functions as a 1-bit output-only port.

Remark When the device is reset, P130 outputs a low level. Therefore, to output a high level from P130 before the device is reset, the output signal of P130 can be used as a pseudo reset signal of the CPU (see the figure for **Remark** in **5.2.10 Port 13**).

2.2.11 P140, P141 (port 14)

P140 and P141 function as a 2-bit I/O port. These pins also function as external interrupt request input, clock output, buzzer output.

The following operation modes can be specified in 1-bit units.

(1) Port mode

P140 and P141 function as a 2-bit I/O port. P140 and P141 can be set to input or output port in 1-bit units using port mode register 14 (PM14). Use of an on-chip pull-up resistor can be specified by pull-up resistor option register 14 (PU14).

(2) Control mode

P140 and P141 function as external interrupt request input, clock output, buzzer output.

(a) INTP6, INTP7

These are the external interrupt request input pins for which the valid edge (rising edge, falling edge, or both rising and falling edges) can be specified.

(b) PCL

This is a clock output pin.

(c) BUZ

This is a buzzer output pin.

★ 2.2.12 AV_{REF}

This is the A/D converter reference voltage input pin and the positive power supply pin of P20 to P27 and A/D converter.

When the A/D converter is not used, connect this pin directly to EV_{DD} or V_{DD}^{Note}.

Note Make the AV_{REF} pin the same potential as the V_{DD} pin when port 2 is used as a digital port.

2.2.13 AV_{SS}

This is the A/D converter ground potential pin. Even when the A/D converter is not used, always use this pin with the same potential as the V_{SS} pin.

2.2.14 $\overline{\text{RESET}}$

This is the active-low system reset input pin.

2.2.15 REGC

This is the pin for connecting regulator output (2.5 V) stabilization capacitance for internal operation. Connect this pin to V_{SS} via a capacitor (0.47 μF : target).

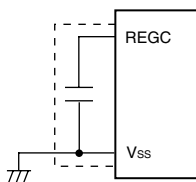

★ **Caution** Keep the wiring length as short as possible for the broken-line part in the above figure.

★ **2.2.16 V_{DD} and EV_{DD}**

V_{DD} is the positive power supply pin for other than P121 to P124 and ports.

EV_{DD} is the positive power supply pin for ports other than P20 to P27 and P121 to P124.

★ **2.2.17 V_{SS} and EV_{SS}**

V_{SS} is the ground potential pin for other than P121 to P124 and ports.

EV_{SS} is the ground potential pin for ports other than P20 to P27 and P121 to P124.

2.2.18 FLMD0

This is a pin for setting flash memory programming mode.

Connect FLMD0 to EV_{SS} or V_{SS} in the normal operation mode.

In flash memory programming mode, connect this pin to the flash programmer.

2.3 Pin I/O Circuits and Recommended Connection of Unused Pins

Table 2-2 shows the types of pin I/O circuits and the recommended connections of unused pins.

See **Figure 2-1** for the configuration of the I/O circuit of each type.

Table 2-2. Pin I/O Circuit Types (1/2)

Pin Name	I/O Circuit Type	I/O	Recommended Connection of Unused Pins	
P00/TI000	5-AH	I/O	Input: Independently connect to EV _{DD} or EV _{SS} via a resistor. Output: Leave open.	
P01/TI010/TO00				
P02/SO11 ^{Note 1}	5-AG			
P03/SI11 ^{Note 1}	5-AG (μ PD78F0531, 78F0532, 78F0533), 5-AH (μ PD78F0534, 78F0535, 78F0536, 78F0537, 78F0537D)			
P04/ $\overline{\text{SCK}}11$ ^{Note 1}				
P05/ $\overline{\text{SSI}}11$ ^{Note 1} /TI001 ^{Note 1}				
P06/TI011 ^{Note 1} /TO01 ^{Note 1}				
P10/ $\overline{\text{SCK}}10$ /TxD0	5-AH			
P11/SI10/RxD0				
P12/SO10	5-AG			
P13/TxD6				
P14/RxD6	5-AH			
P15/TOH0	5-AG			
P16/TOH1/INTP5	5-AH			
P17/TI50/TO50				
P20/ANI0 to P27/ANI7 ^{Note 2}	11-G			<Analog setting> Connect to AV _{REF} or AV _{SS} . <Digital setting> Input: Independently connect to EV _{DD} or EV _{SS} via a resistor. Output: Leave open.
P30/INTP1	5-AH			Input: Independently connect to EV _{DD} or EV _{SS} via a resistor. Output: Leave open.
P31/INTP2				
P32/INTP3				
P33/TI51/TO51/INTP4				
P40 to P43	5-AG			
P50 to P53				
P60/SCL0	13-AD	Input: Connect to EV _{SS} . Output: Leave this pin open at low-level output after clearing the output latch of the port to 0.		
P61/SDA0				
P62/EXSCL0				
P63	13-P			
P70/KR0 to P77/KR7	5-AH	Input: Independently connect to EV _{DD} or EV _{SS} via a resistor. Output: Leave open.		
P120/INTP0/EXLVI				

Notes 1. Available only in the μ PD78F0534, 78F0535, 78F0536, 78F0537, and 78F0537D.

2. P20/ANI0 to P27/ANI7 are set in the analog input mode after release of reset.

Table 2-2. Pin I/O Circuit Types (2/2)

Pin Name	I/O Circuit Type	I/O	Recommended Connection of Unused Pins
★ P121/X1 ^{Note 1}	37	I/O	Input: Independently connect to EV _{DD} or EV _{SS} via a resistor. Output: Leave open.
★ P122/X2/EXCLK ^{Note 1}			
★ P123/XT1 ^{Note 1}			
★ P124/XT2/EXCLKS ^{Note 1}			
P130	3-C	Output	Leave open.
P140/PCL/INTP6	5-AH	I/O	Input: Independently connect to EV _{DD} or EV _{SS} via a resistor. Output: Leave open.
P141/BUZ/INTP7			
RESET	2	Input	–
FLMD0	38	Input	Connect to EV _{SS} or V _{SS} .
AV _{REF}	–	–	Connect directly to EV _{DD} or V _{DD} ^{Note 2} .
AV _{SS}			Connect directly to EV _{SS} or V _{SS} .

Notes 1. Use recommended connection above in I/O port mode (see **Figure 6-2 Format of Clock Operation Mode Select Register (OSCCTL)**) when these pins are not used.

2. Make the same potential as the V_{DD} pin when port 2 is used as a digital port.

Figure 2-1. Pin I/O Circuit List (1/2)

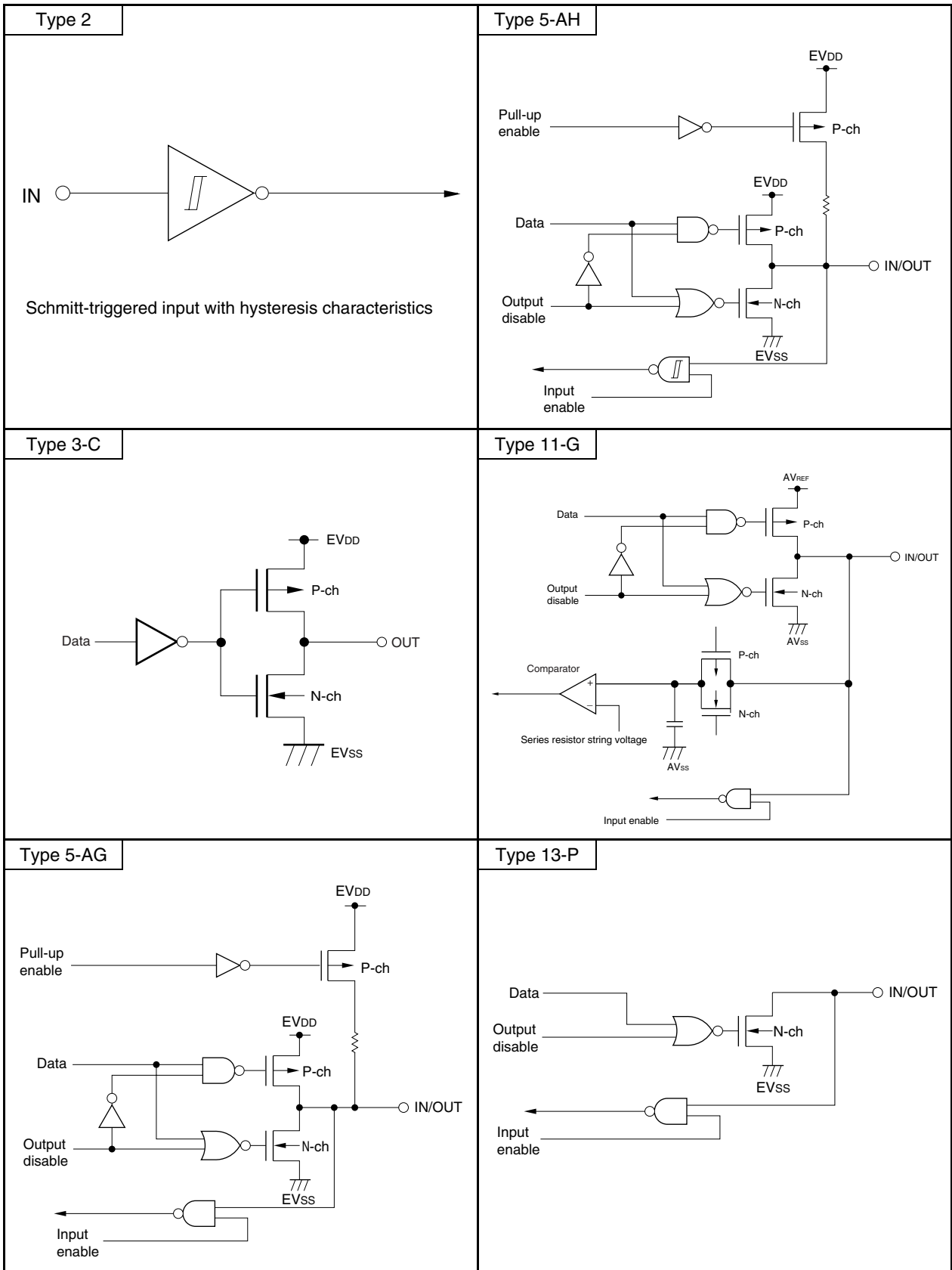
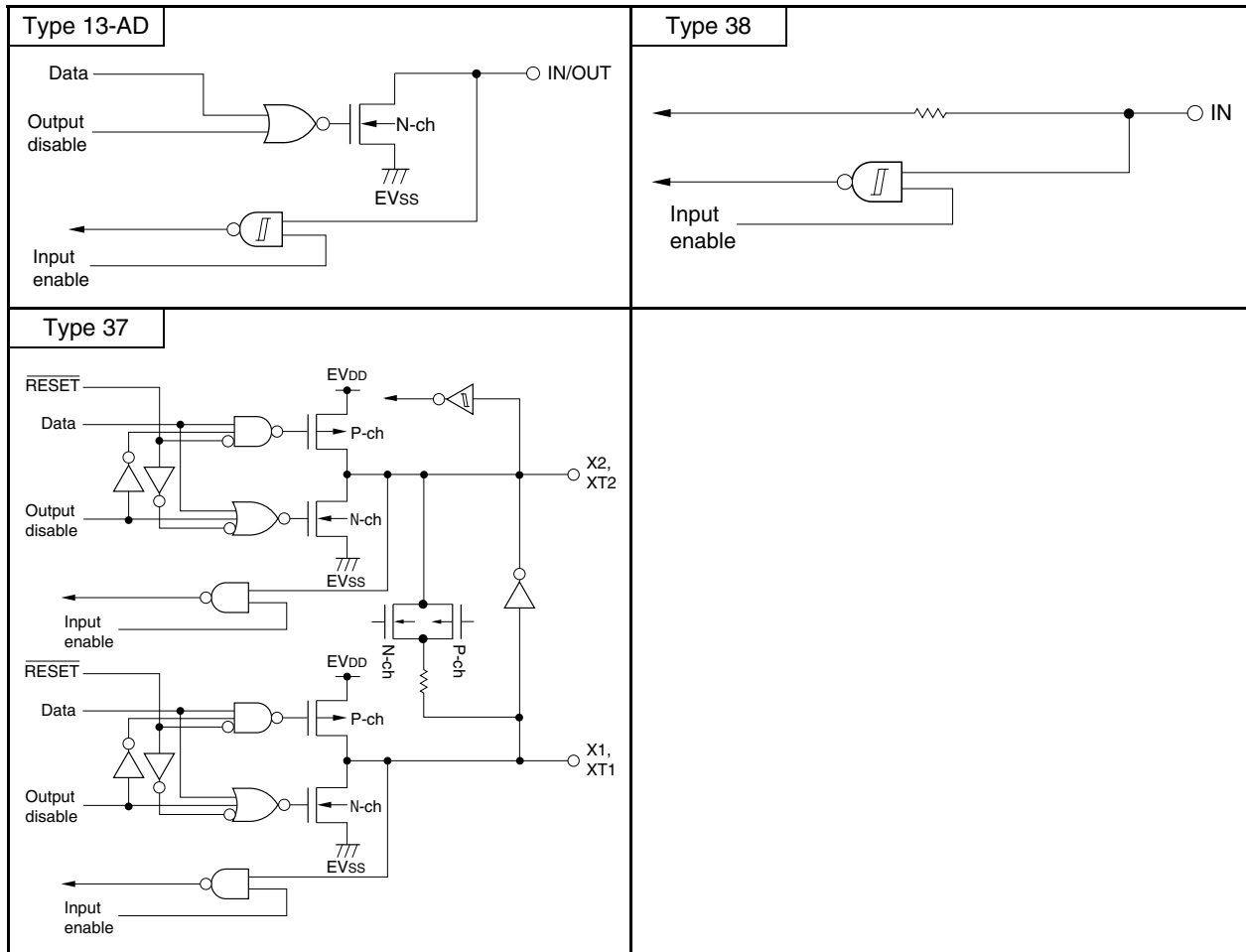

Figure 2-1. Pin I/O Circuit List (2/2)



CHAPTER 3 CPU ARCHITECTURE

3.1 Memory Space

Products in the 78K0/KE2 can access a 64 KB memory space. Figures 3-1 to 3-8 show the memory maps.

Cautions 1. Regardless of the internal memory capacity, the initial values of the internal memory size switching register (IMS) and internal expansion RAM size switching register (IXS) of all products in the 78K0/KE2 are fixed (IMS = CFH, IXS = 0CH). Therefore, set the value corresponding to each product as indicated below.

★ 2. To set the memory size, set IMS and then IXS. Set the memory size so that the internal ROM and internal expansion RAM areas do not overlap.

★ **Table 3-1. Set Values of Internal Memory Size Switching Register (IMS) and Internal Expansion RAM Size Switching Register (IXS)**

Flash Memory Version (78K0/KE2)	IMS	IXS	ROM Capacity	Internal High-Speed RAM Capacity	Internal Expansion RAM Capacity
μ PD78F0531	04H	0CH	16 KB	768 bytes	–
μ PD78F0532	C6H		24 KB	1 KB	
μ PD78F0533	C8H		32 KB		
μ PD78F0534	CCH	0AH	48 KB	1 KB	1 KB
μ PD78F0535	CFH	0BH	60 KB		2 KB
μ PD78F0536	CCH ^{Note}	04H	96 KB ^{Note}		4 KB
μ PD78F0537, 78F0537D	CCH ^{Note}	00H	128 KB ^{Note}		6 KB

Note The μ PD78F0536, 78F0537, and 78F0537D have internal ROMs of 96 KB and 128 KB, respectively. However, the set value of IMS of these devices is the same as those of the 48 KB product because memory banks are used. For how to set the memory banks, see **4.2 Memory Bank Select Register (BANK)**.

★

Figure 3-1. Memory Map (μPD78F0531)

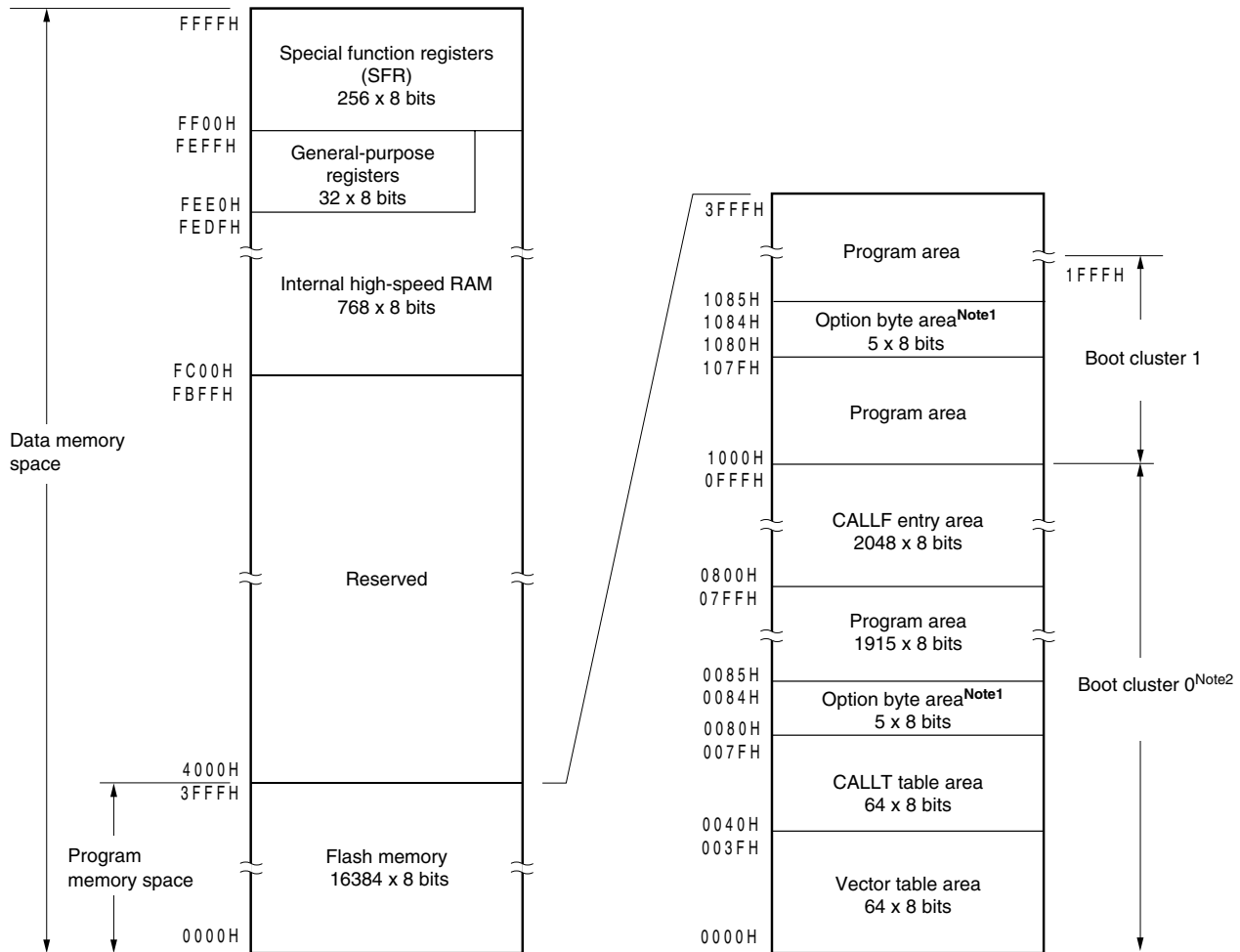

- Notes**
1. When boot swap is not used: Set the option bytes to 0080H to 0084H.
When boot swap is used: Set the option bytes to 0080H to 0084H and 1080H to 1084H.
 2. Writing boot cluster 0 can be prohibited depending on the setting of security (see **26.8 Security Setting**).

★

Figure 3-2. Memory Map (μ PD78F0532)

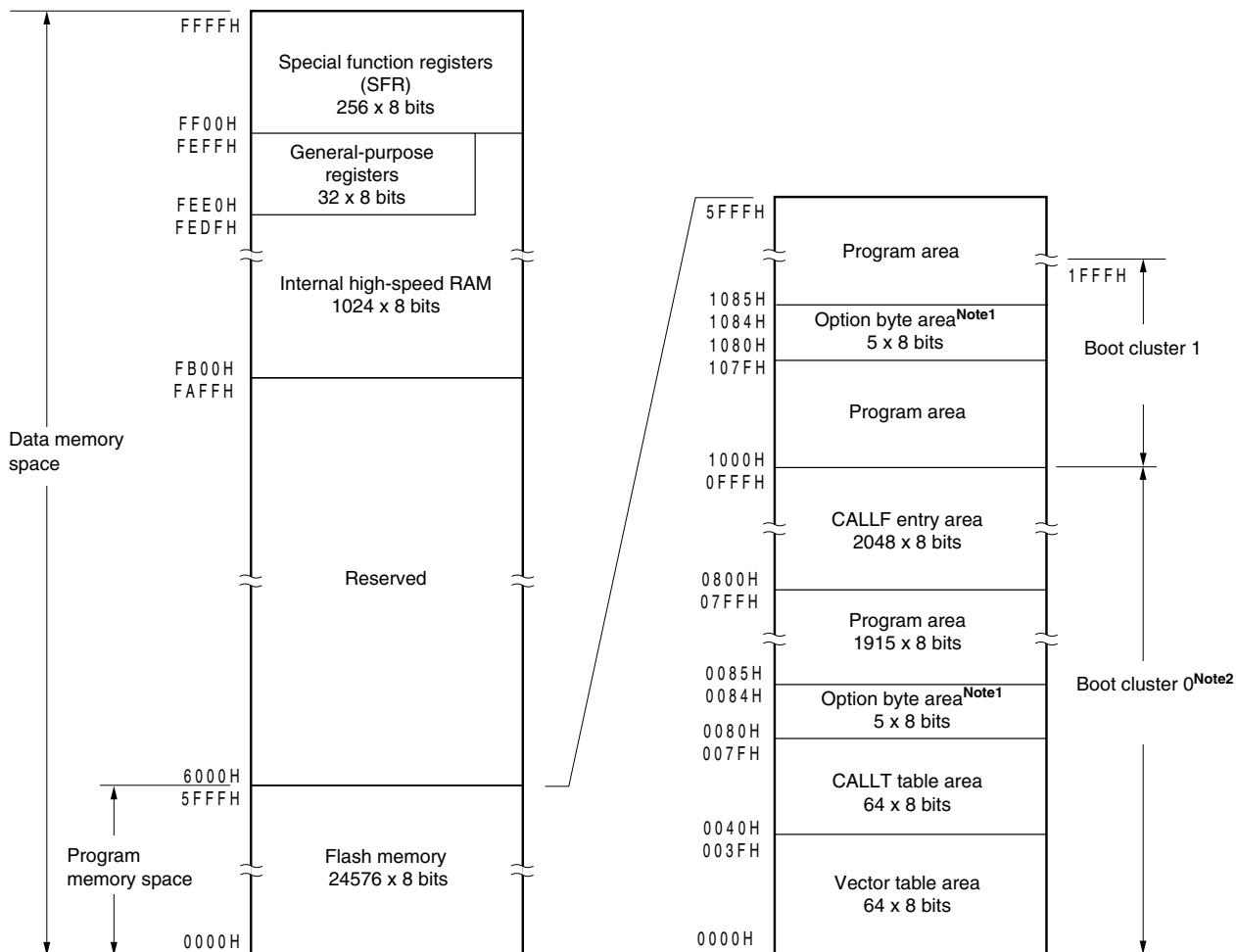

- Notes**
- When boot swap is not used: Set the option bytes to 0080H to 0084H.
When boot swap is used: Set the option bytes to 0080H to 0084H and 1080H to 1084H.
 - Writing boot cluster 0 can be prohibited depending on the setting of security (see **26.8 Security Setting**).

★

Figure 3-3. Memory Map (μPD78F0533)

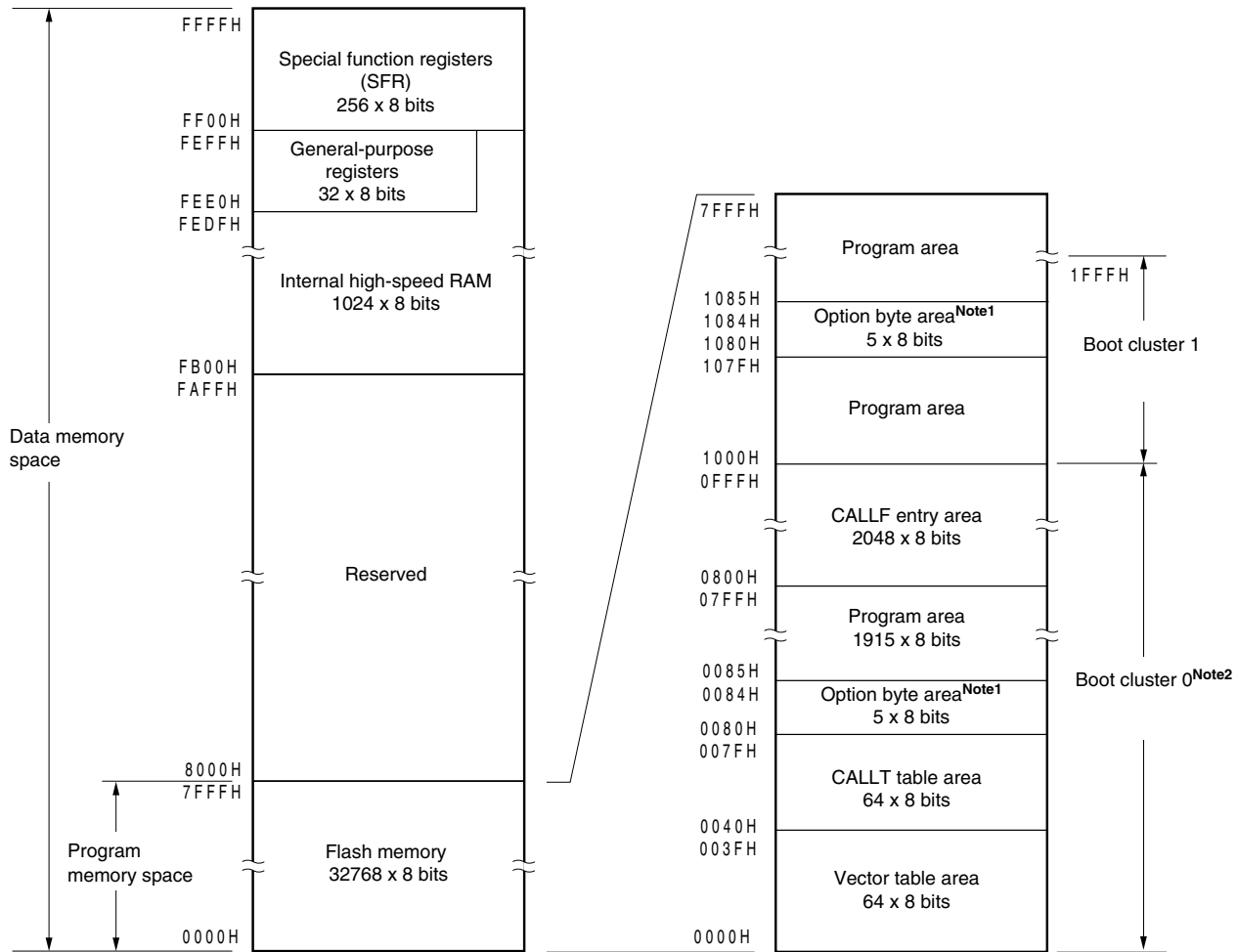

- Notes**
1. When boot swap is not used: Set the option bytes to 0080H to 0084H.
When boot swap is used: Set the option bytes to 0080H to 0084H and 1080H to 1084H.
 2. Writing boot cluster 0 can be prohibited depending on the setting of security (see **26.8 Security Setting**).

★

Figure 3-4. Memory Map (μ PD78F0534)

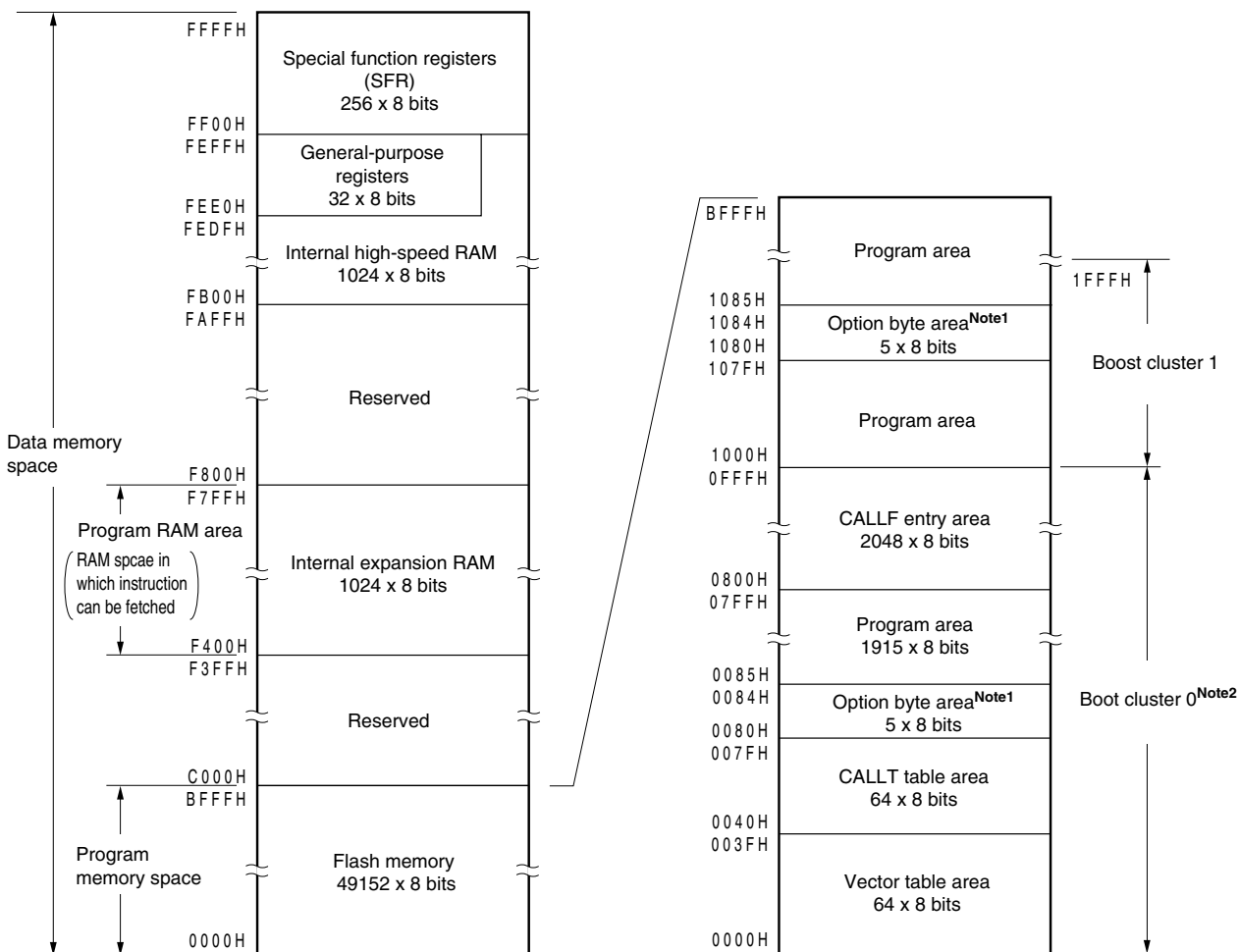

- Notes**
1. When boot swap is not used: Set the option bytes to 0080H to 0084H.
When boot swap is used: Set the option bytes to 0080H to 0084H and 1080H to 1084H.
 2. Writing boot cluster 0 can be prohibited depending on the setting of security (see **26.8 Security Setting**).

★

Figure 3-5. Memory Map (μ PD78F0535)

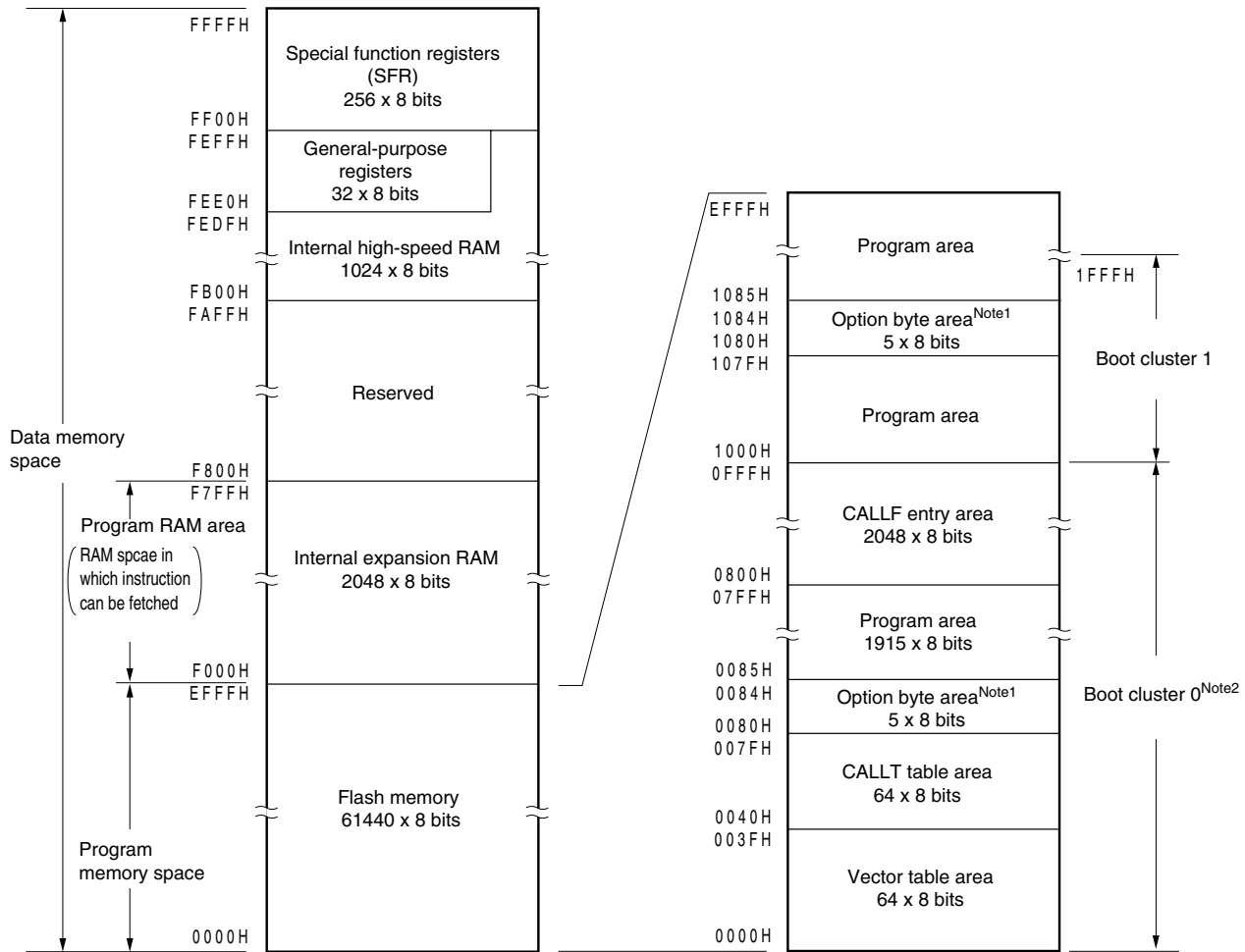

- Notes**
1. When boot swap is not used: Set the option bytes to 0080H to 0084H.
When boot swap is used: Set the option bytes to 0080H to 0084H and 1080H to 1084H.
 2. Writing boot cluster 0 can be prohibited depending on the setting of security (see **26.8 Security Setting**).

Figure 3-6. Memory Map (μ PD78F0536)

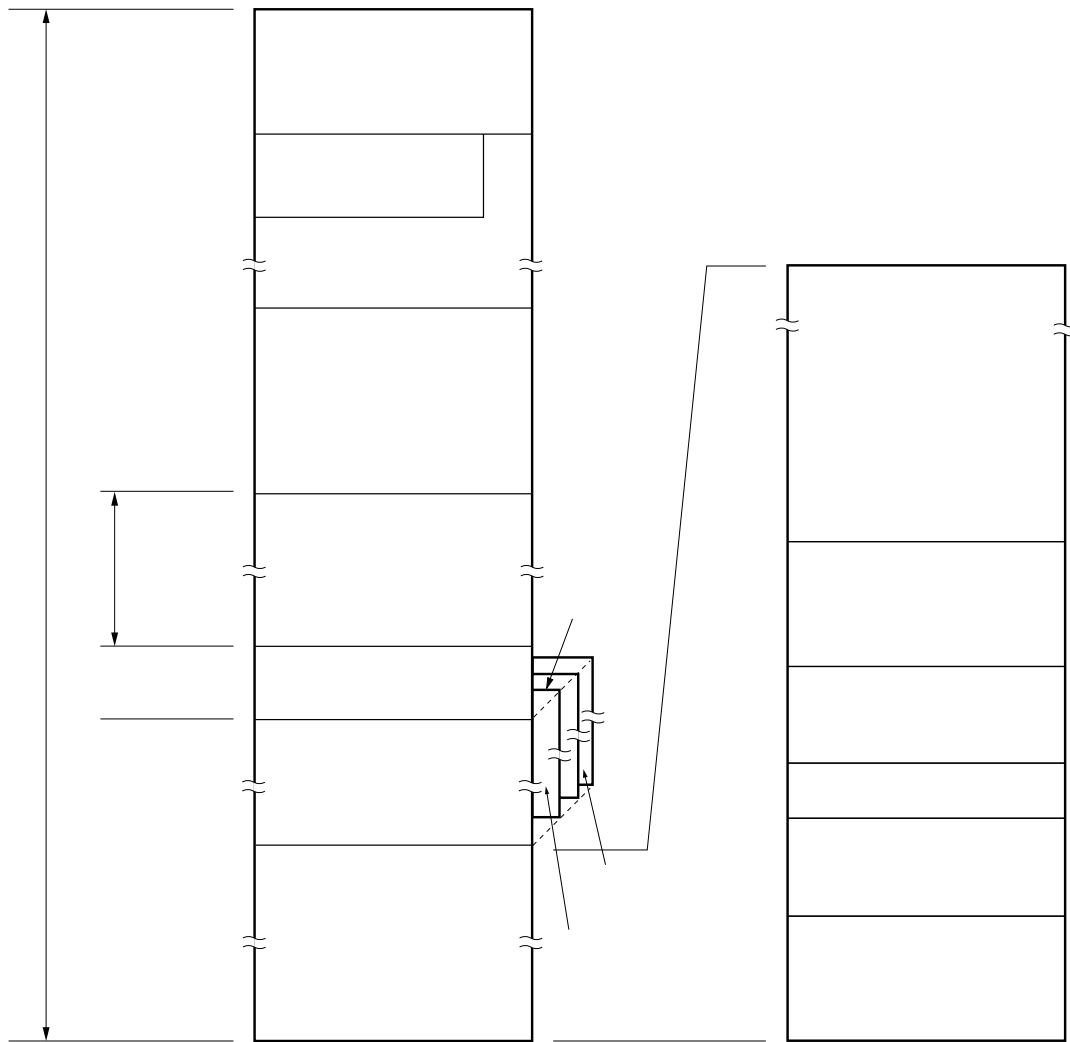
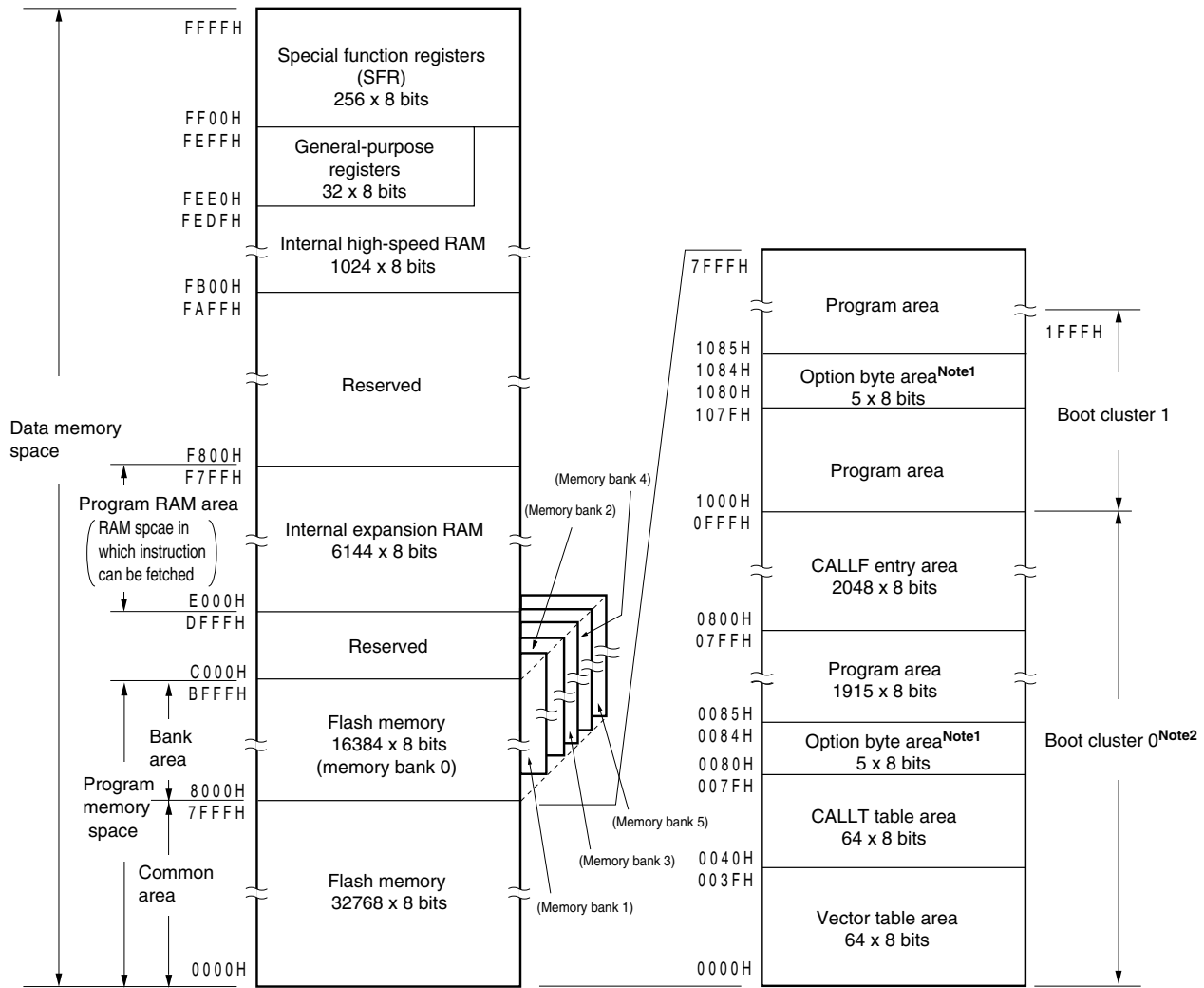

Figure 3-7. Memory Map (μ PD78F0537)



- Notes**
1. When boot swap is not used: Set the option bytes to 0080H to 0084H.
When boot swap is used: Set the option bytes to 0080H to 0084H and 1080H to 1084H.
 2. Writing boot cluster 0 can be prohibited depending on the setting of security (see **26.8 Security Setting**).

★

Figure 3-8. Memory Map (μ PD78F0537D)

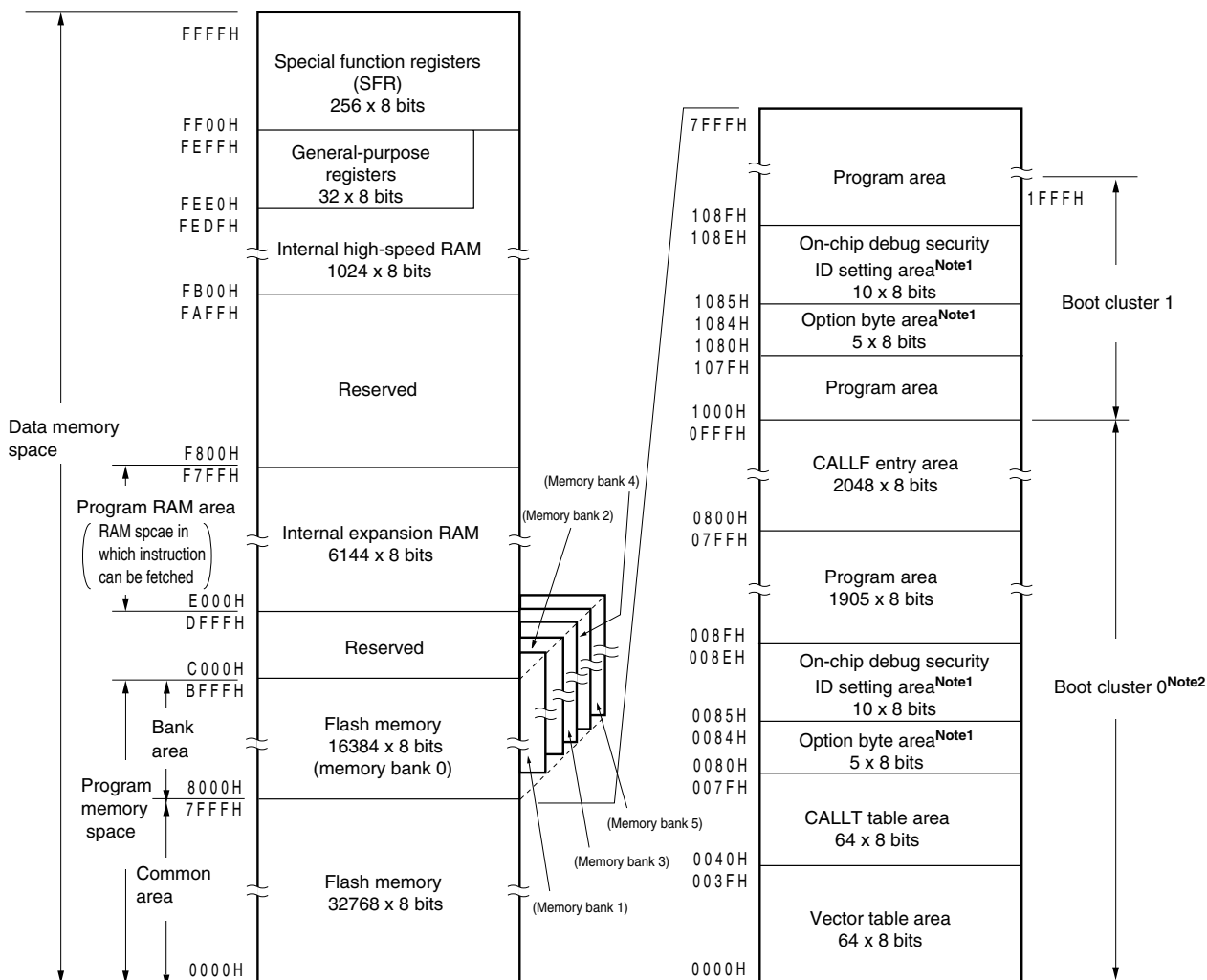

- Notes**
1. When boot swap is not used: Set the option bytes to 0080H to 0084H, and the on-chip debug security IDs to 0085H to 008EH.

When boot swap is used: Set the option bytes to 0080H to 0084H and 1080H to 1084H, and the on-chip debug security IDs to 0085H to 008EH and 1085H to 108EH.
 2. Writing boot cluster 0 can be prohibited depending on the setting of security (see **26.8 Security Setting**).

3.1.1 Internal program memory space

The internal program memory space stores the program and table data. Normally, it is addressed with the program counter (PC).

78K0/KE2 products incorporate internal ROM (flash memory), as shown below.

Table 3-2. Internal ROM Capacity

Part Number	Internal ROM	
	Structure	Capacity
μ PD78F0531	Flash memory	16384 \times 8 bits (0000H to 3FFFH)
μ PD78F0532		24576 \times 8 bits (0000H to 5FFFH)
μ PD78F0533		32768 \times 8 bits (0000H to 7FFFH)
μ PD78F0534		49152 \times 8 bits (0000H to BFFFH)
μ PD78F0535		61440 \times 8 bits (0000H to EFFFH)
μ PD78F0536		98304 \times 8 bits (0000H to 7FFFH (common area) + 8000H to BFFFH (bank area) \times 4)
μ PD78F0537, 78F0537D		131072 \times 8 bits (0000H to 7FFFH (common area) + 8000H to BFFFH (bank area) \times 6)

The internal program memory space is divided into the following areas.

(1) Vector table area

The 64-byte area 0000H to 003FH is reserved as a vector table area. The program start addresses for branch upon reset or generation of each interrupt request are stored in the vector table area.

Of the 16-bit address, the lower 8 bits are stored at even addresses and the higher 8 bits are stored at odd addresses.

Table 3-3. Vector Table

Vector Table Address	Interrupt Source	Vector Table Address	Interrupt Source
0000H	RESET input, POC, LVI, WDT	0020H	INTTM000
0004H	INTLVI	0022H	INTTM010
0006H	INTP0	0024H	INTAD
0008H	INTP1	0026H	INTSR0
000AH	INTP2	0028H	INTWTI
000CH	INTP3	002AH	INTTM51
000EH	INTP4	002CH	INTKR
0010H	INTP5	002EH	INTWT
0012H	INTSRE6	0030H	INTP6
0014H	INTSR6	0032H	INTP7
0016H	INTST6	0034H	INTIIC0/INTDMU ^{Note}
0018H	INTCSI10/INTST0	0036H ^{Note}	INTCSI11 ^{Note}
001AH	INTTMH1	0038H ^{Note}	INTTM001 ^{Note}
001CH	INTTMH0	003AH ^{Note}	INTTM011 ^{Note}
001EH	INTTM50	003EH	BRK

Note Available only in the μ PD78F0534, 78F0535, 78F0536, 78F0537, and 78F0537D.

(2) CALLT instruction table area

The 64-byte area 0040H to 007FH can store the subroutine entry address of a 1-byte call instruction (CALLT).

★ **(3) Option byte area**

A 5-byte area of 0080H to 0084H and 1080H to 1084H can be used as an option byte area. Set the option byte at 0080H to 0084H when the boot swap is not used, and at 0080H to 0084H and 1080H to 1084H when the boot swap is used. For details, see **CHAPTER 25 OPTION BYTE**.

(4) CALLF instruction entry area

The area 0800H to 0FFFH can perform a direct subroutine call with a 2-byte call instruction (CALLF).

★ **(5) On-chip debug security ID setting area (μ PD78F0537D only)**

A 10-byte area of 0085H to 008EH and 1085H to 108EH can be used as an on-chip debug security ID setting area. Set the on-chip debug security ID of 10 bytes at 0085H to 008EH when the boot swap is not used and at 0085H to 008EH and 1085H to 108EH when the boot swap is used. For details, see **CHAPTER 27 ON-CHIP DEBUG FUNCTION (μ PD78F0537D ONLY)**.

★ **3.1.2 Memory bank (μ PD78F0536, 78F0537, and 78F0537D only)**

The 16 KB area 8000H to BFFFH is assigned to memory banks 0 to 3 in the μ PD78F0536, and assigned to memory banks 0 to 5 in the μ PD78F0537 and 78F0537D.

The banks are selected by using a memory bank select register (BANK). For details, see **CHAPTER 4 MEMORY BANK SELECT FUNCTION (μ PD78F0536, 78F0537, AND 78F0537D ONLY)**.

- Cautions**
1. Instructions cannot be fetched between different memory banks.
 2. Branch and access cannot be directly executed between different memory banks. Execute branch or access between different memory banks via the common area.
 3. Allocate interrupt servicing in the common area.
 4. An instruction that extends from 7FFFH to 8000H can only be executed in memory bank 0.

3.1.3 Internal data memory space

78K0/KE2 products incorporate the following RAMs.

(1) Internal high-speed RAM

Table 3-4. Internal High-Speed RAM Capacity

Part Number	Internal High-Speed RAM
μ PD78F0531	768 \times 8 bits (FC00H to FEFH)
μ PD78F0532	1024 \times 8 bits (FB00H to FEFH)
μ PD78F0533	
μ PD78F0534	
μ PD78F0535	
μ PD78F0536	
μ PD78F0537, 78F0537D	

The 32-byte area FEE0H to FEFH is assigned to four general-purpose register banks consisting of eight 8-bit registers per bank.

This area cannot be used as a program area in which instructions are written and executed.

The internal high-speed RAM can also be used as a stack memory.

(2) Internal expansion RAM**Table 3-5. Internal Expansion RAM Capacity**

Part Number	Internal Expansion RAM
μ PD78F0531	—
μ PD78F0532	
μ PD78F0533	
μ PD78F0534	1024 \times 8 bits (F400H to F7FFH)
μ PD78F0535	2048 \times 8 bits (F000H to F7FFH)
μ PD78F0536	4096 \times 8 bits (E800H to F7FFH)
μ PD78F0537, 78F0537D	6144 \times 8 bits (E000H to F7FFH)

The internal expansion RAM can also be used as a normal data area similar to the internal high-speed RAM, as well as a program area in which instructions can be written and executed.

The internal expansion RAM cannot be used as a stack memory.

3.1.4 Special function register (SFR) area

On-chip peripheral hardware special function registers (SFRs) are allocated in the area FF00H to FFFFH (see **Table 3-6 Special Function Register List** in **3.2.3 Special function registers (SFRs)**).

Caution Do not access addresses to which SFRs are not assigned.

3.1.5 Data memory addressing

Addressing refers to the method of specifying the address of the instruction to be executed next or the address of the register or memory relevant to the execution of instructions.

Several addressing modes are provided for addressing the memory relevant to the execution of instructions for the 78K0/KE2, based on operability and other considerations. For areas containing data memory in particular, special addressing methods designed for the functions of special function registers (SFR) and general-purpose registers are available for use. Figures 3-9 to 3-15 show correspondence between data memory and addressing. For details of each addressing mode, see **3.4 Operand Address Addressing**.

Figure 3-9. Correspondence Between Data Memory and Addressing (μ PD78F0531)

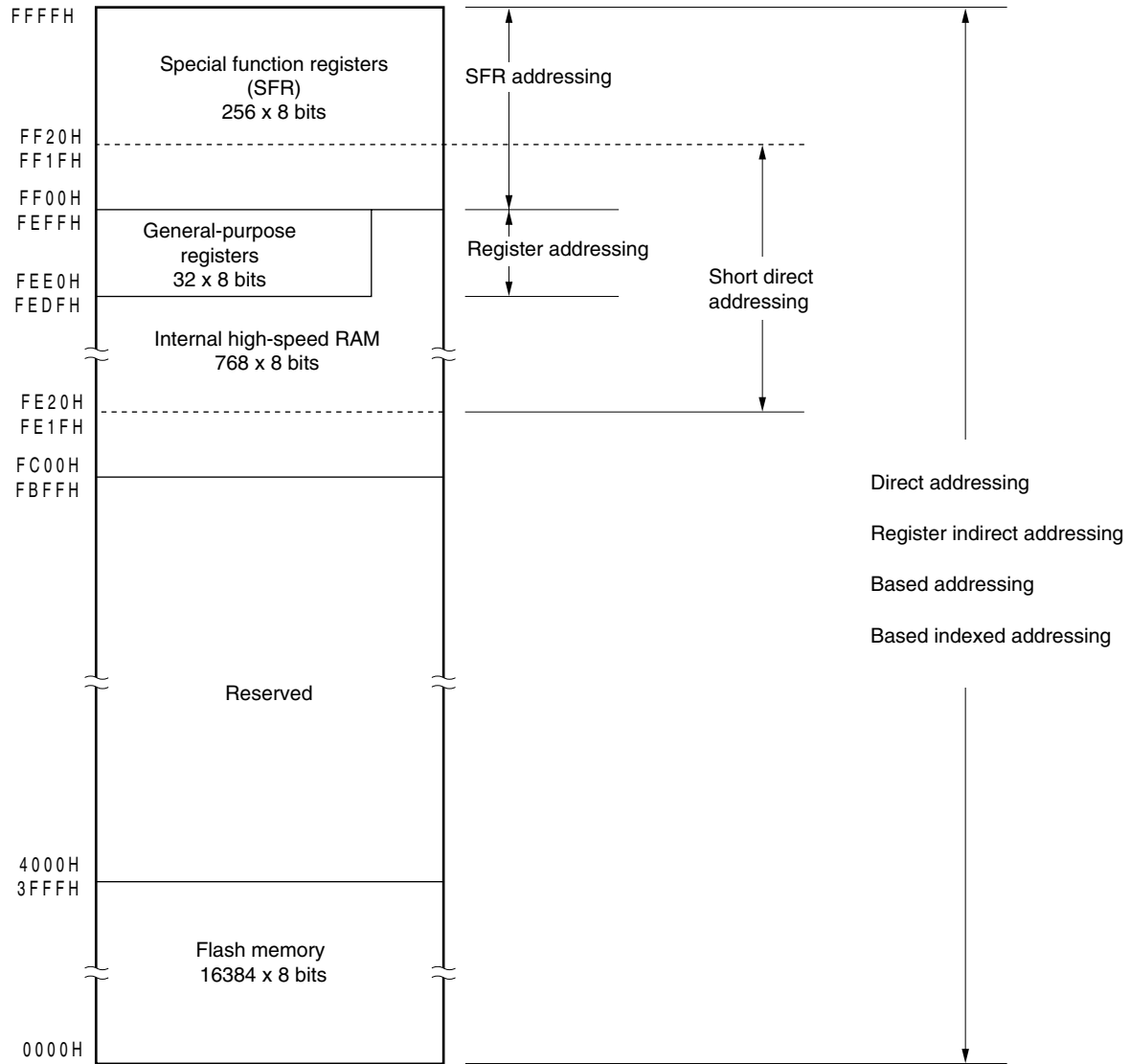

Figure 3-10. Correspondence Between Data Memory and Addressing (μ PD78F0532)

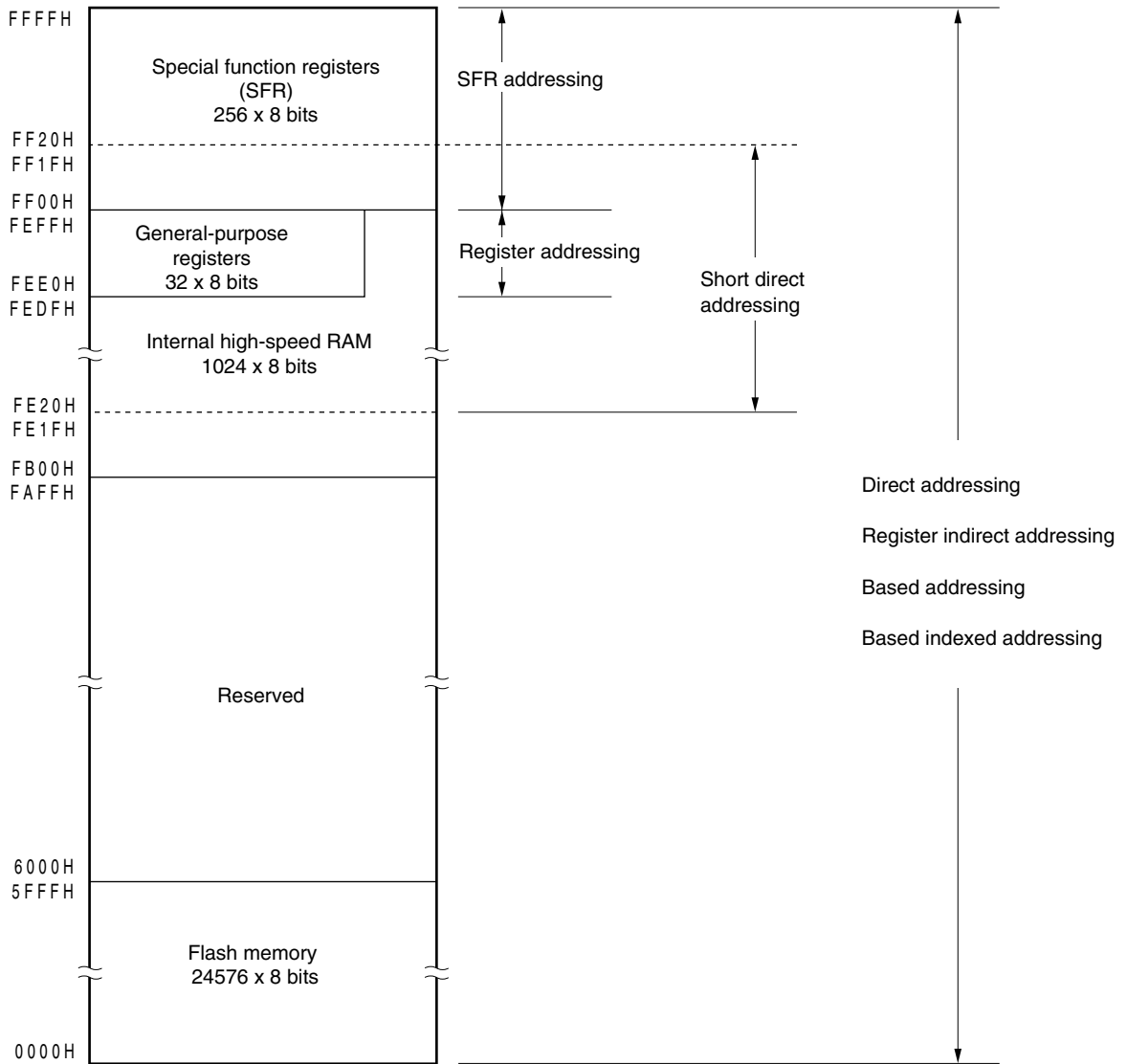

Figure 3-11. Correspondence Between Data Memory and Addressing (μ PD78F0533)

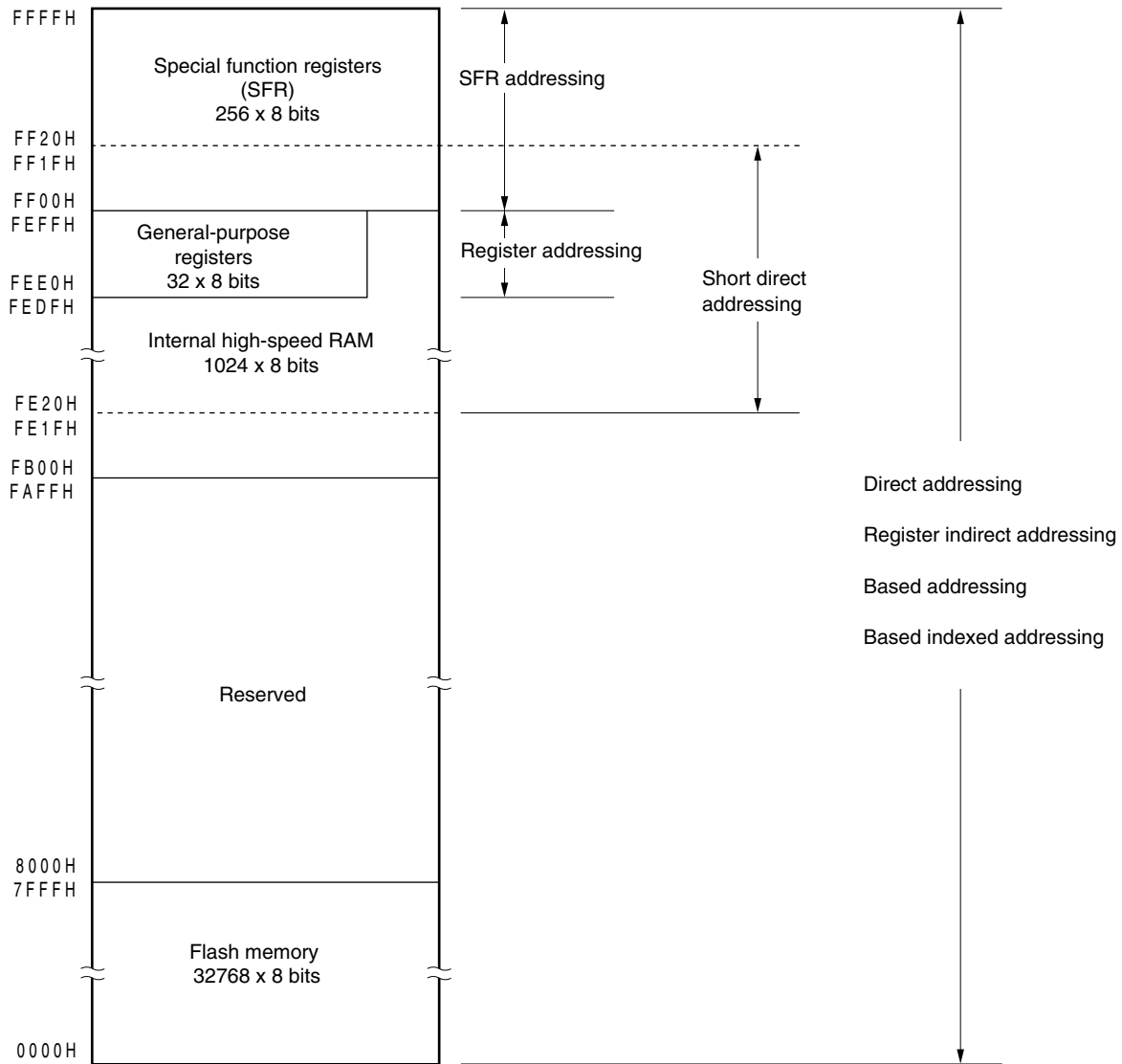

Figure 3-12. Correspondence Between Data Memory and Addressing (μ PD78F0534)

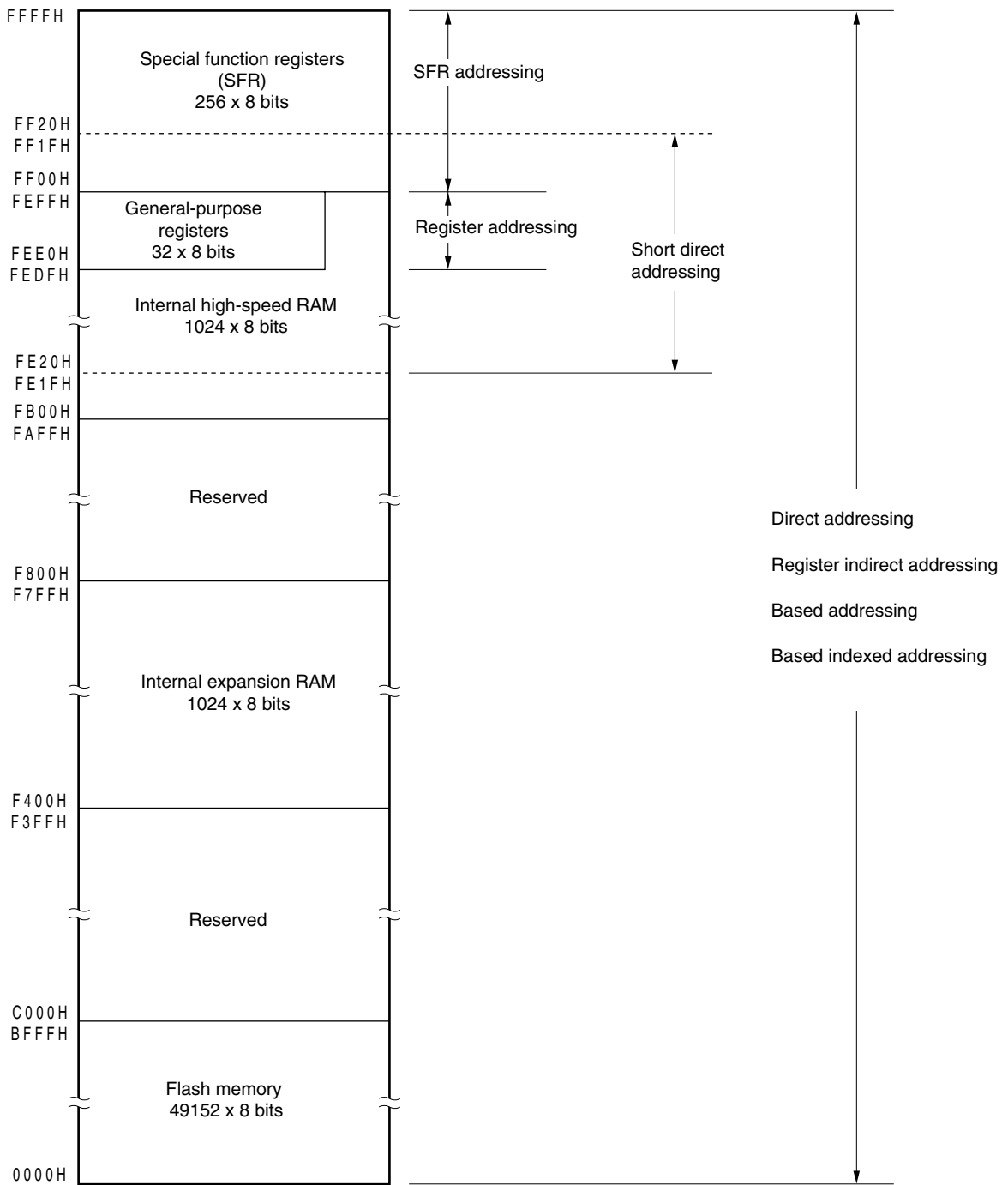

Figure 3-13. Correspondence Between Data Memory and Addressing (μ PD78F0535)

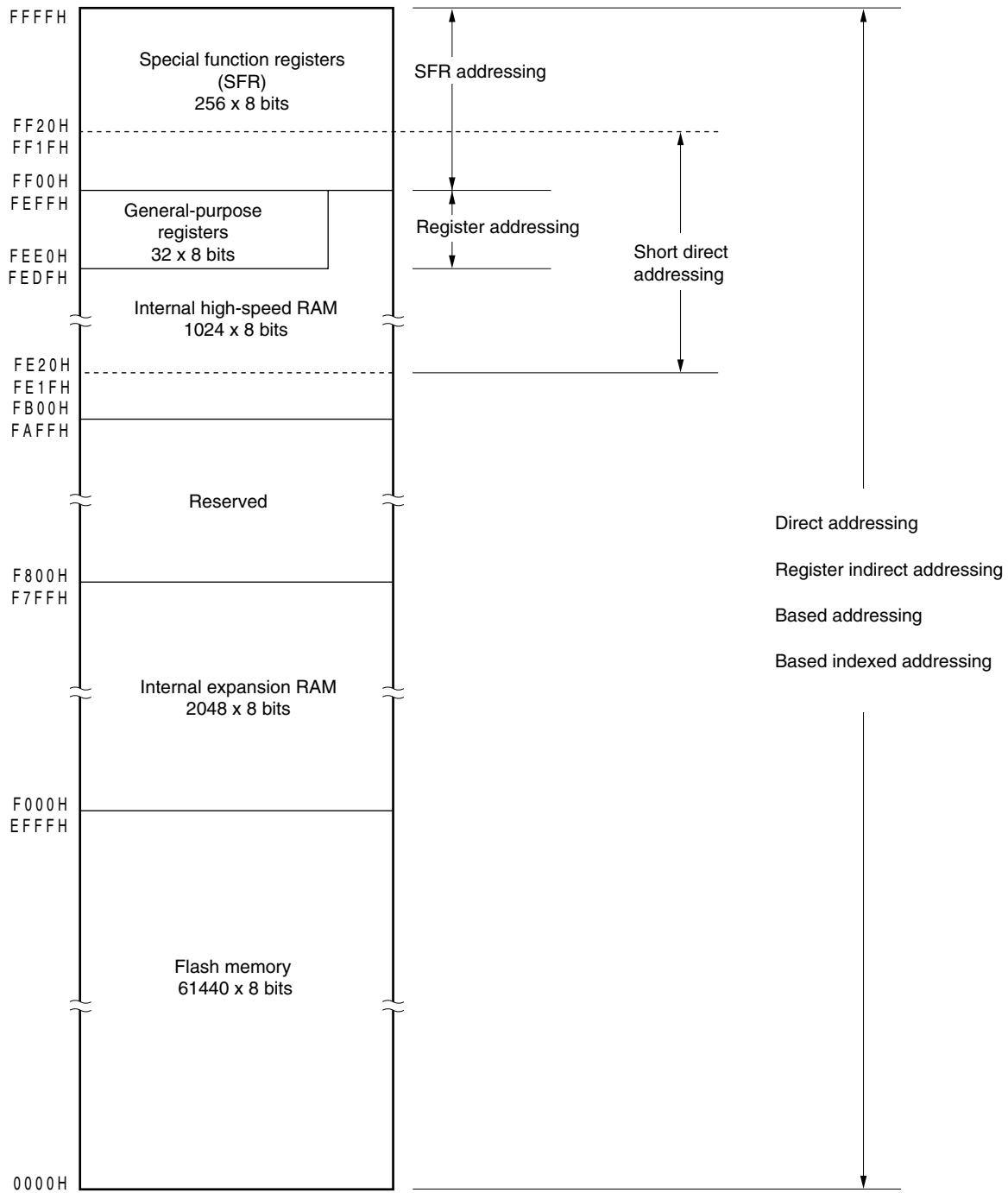
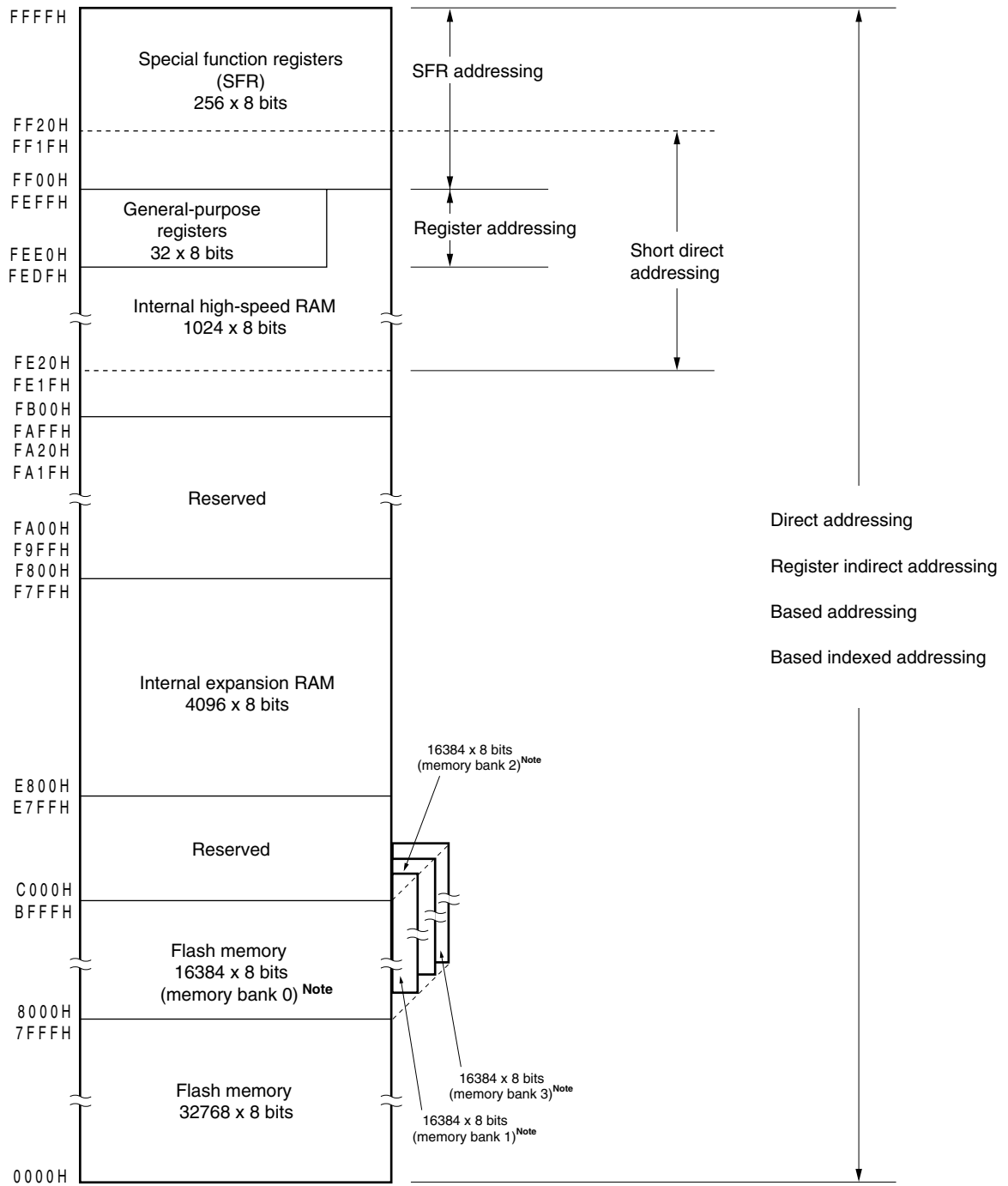
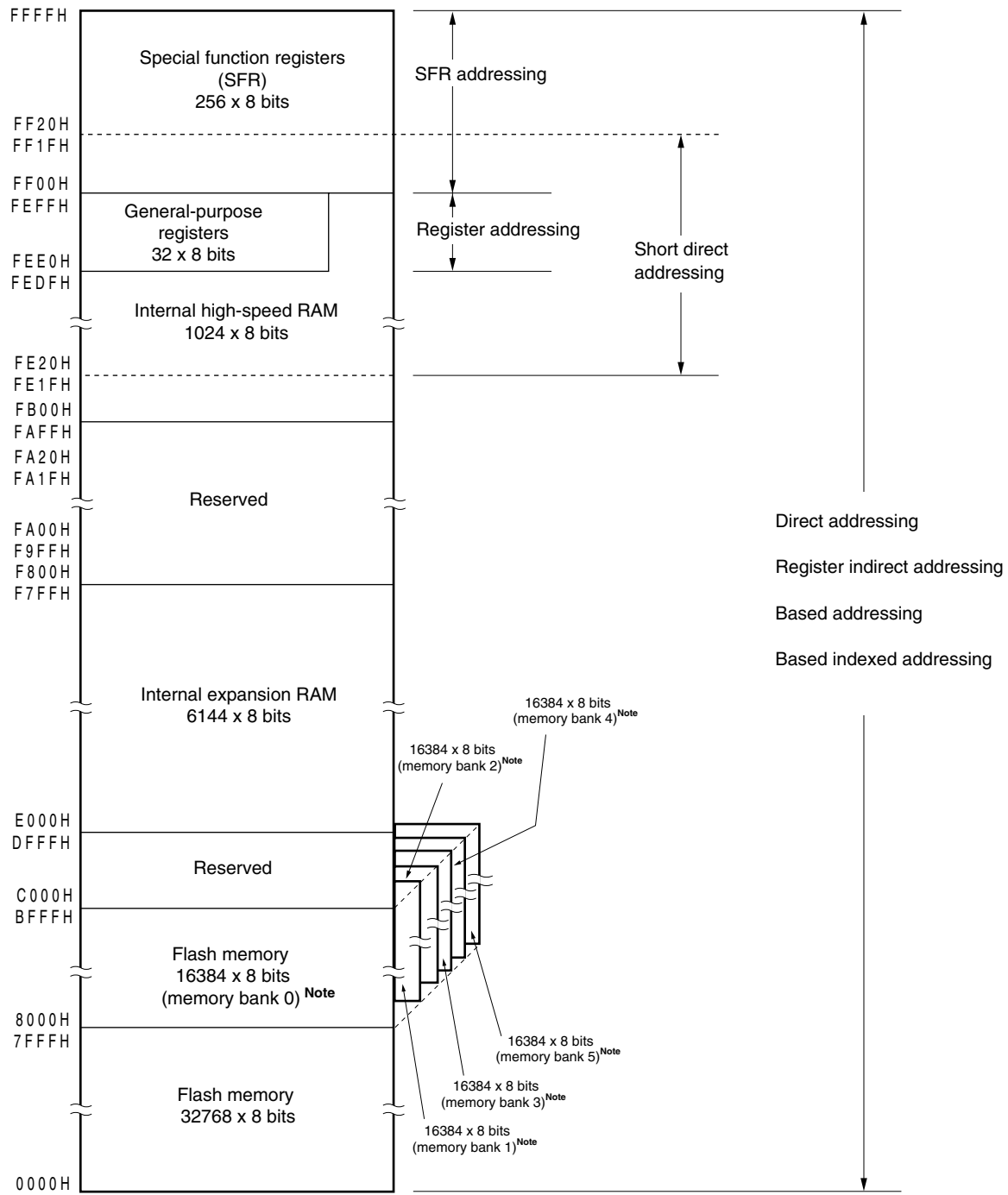

Figure 3-14. Correspondence Between Data Memory and Addressing (μ PD78F0536)



★ **Note** To branch to or address a memory bank that is not set by the memory bank select register (BANK), change the setting of the memory bank by using BANK.

Figure 3-15. Correspondence Between Data Memory and Addressing (μ PD78F0537, 78F0537D)



★ **Note** To branch to or address a memory bank that is not set by the memory bank select register (BANK), change the setting of the memory bank by using BANK.

3.2 Processor Registers

The 78K0/KE2 products incorporate the following processor registers.

3.2.1 Control registers

The control registers control the program sequence, statuses and stack memory. The control registers consist of a program counter (PC), a program status word (PSW) and a stack pointer (SP).

(1) Program counter (PC)

The program counter is a 16-bit register that holds the address information of the next program to be executed. In normal operation, PC is automatically incremented according to the number of bytes of the instruction to be fetched. When a branch instruction is executed, immediate data and register contents are set. Reset signal generation sets the reset vector table values at addresses 0000H and 0001H to the program counter.

Figure 3-16. Format of Program Counter

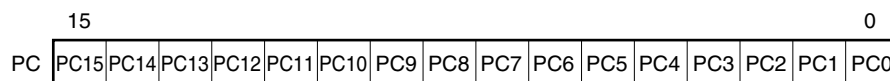

(2) Program status word (PSW)

The program status word is an 8-bit register consisting of various flags set/reset by instruction execution. Program status word contents are stored in the stack area upon interrupt request generation or PUSH PSW instruction execution and are restored upon execution of the RETB, RETI and POP PSW instructions. Reset signal generation sets PSW to 02H.

Figure 3-17. Format of Program Status Word

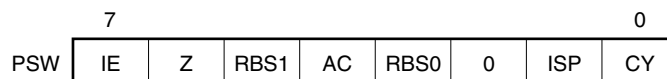

(a) Interrupt enable flag (IE)

This flag controls the interrupt request acknowledge operations of the CPU.

When 0, the IE flag is set to the interrupt disabled (DI) state, and all maskable interrupt requests are disabled. When 1, the IE flag is set to the interrupt enabled (EI) state and interrupt request acknowledgement is controlled with an in-service priority flag (ISP), an interrupt mask flag for various interrupt sources, and a priority specification flag.

The IE flag is reset (0) upon DI instruction execution or interrupt acknowledgement and is set (1) upon EI instruction execution.

(b) Zero flag (Z)

When the operation result is zero, this flag is set (1). It is reset (0) in all other cases.

(c) Register bank select flags (RBS0 and RBS1)

These are 2-bit flags to select one of the four register banks.

In these flags, the 2-bit information that indicates the register bank selected by SEL RBn instruction execution is stored.

(d) Auxiliary carry flag (AC)

If the operation result has a carry from bit 3 or a borrow at bit 3, this flag is set (1). It is reset (0) in all other cases.

(e) In-service priority flag (ISP)

This flag manages the priority of acknowledgeable maskable vectored interrupts. When this flag is 0, low-level vectored interrupt requests specified by a priority specification flag register (PR0L, PR0H, PR1L, PR1H) (see 19.3 (3) **Priority specification flag registers (PR0L, PR0H, PR1L, PR1H)**) can not be acknowledged. Actual request acknowledgement is controlled by the interrupt enable flag (IE).

(f) Carry flag (CY)

This flag stores overflow and underflow upon add/subtract instruction execution. It stores the shift-out value upon rotate instruction execution and functions as a bit accumulator during bit operation instruction execution.

(3) Stack pointer (SP)

This is a 16-bit register to hold the start address of the memory stack area. Only the internal high-speed RAM area can be set as the stack area.

Figure 3-18. Format of Stack Pointer

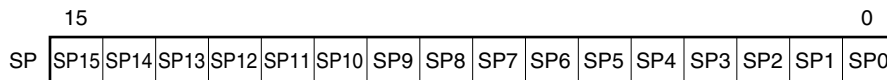

The SP is decremented ahead of write (save) to the stack memory and is incremented after read (restored) from the stack memory.

Each stack operation saves/restores data as shown in Figures 3-19 and 3-20.

Caution Since reset signal generation makes the SP contents undefined, be sure to initialize the SP before using the stack.

Figure 3-19. Data to Be Saved to Stack Memory

(a) PUSH rp instruction (when SP = FEE0H)

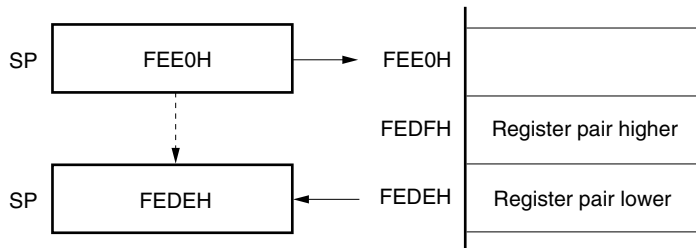

(b) CALL, CALLF, CALLT instructions (when SP = FEE0H)

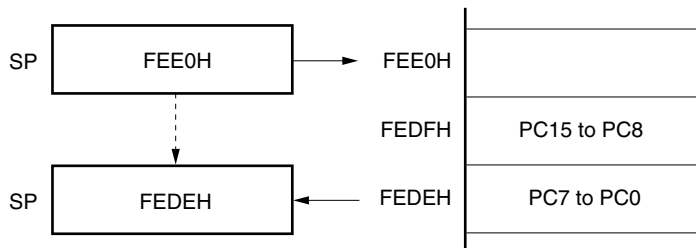

(c) Interrupt, BRK instructions (when SP = FEE0H)

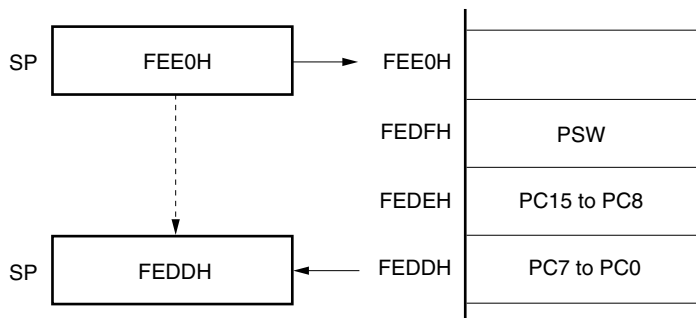
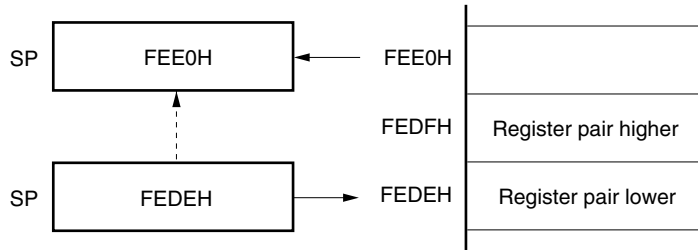
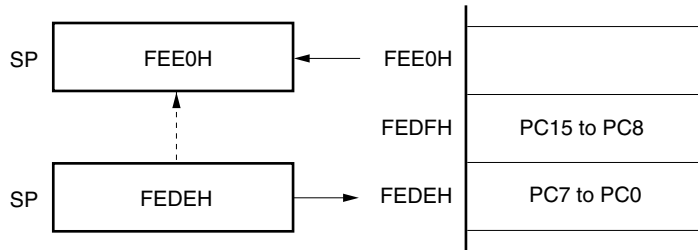

Figure 3-20. Data to Be Restored from Stack Memory

(a) POP rp instruction (when SP = FEDEH)



(b) RET instruction (when SP = FEDEH)



(c) RETI, RETB instructions (when SP = FEDDH)

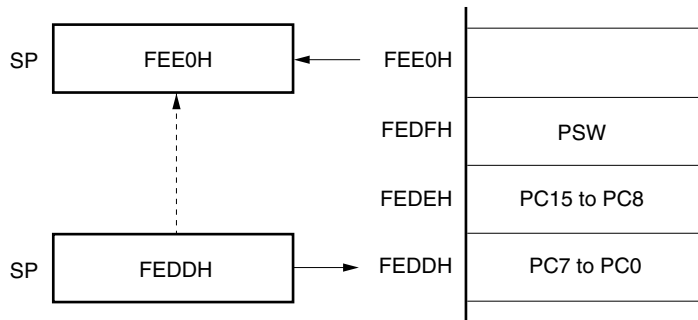

3.2.2 General-purpose registers

General-purpose registers are mapped at particular addresses (FEE0H to FEFFH) of the data memory. The general-purpose registers consists of 4 banks, each bank consisting of eight 8-bit registers (X, A, C, B, E, D, L, and H).

Each register can be used as an 8-bit register, and two 8-bit registers can also be used in a pair as a 16-bit register (AX, BC, DE, and HL).

These registers can be described in terms of function names (X, A, C, B, E, D, L, H, AX, BC, DE, and HL) and absolute names (R0 to R7 and RP0 to RP3).

Register banks to be used for instruction execution are set by the CPU control instruction (SEL RBn). Because of the 4-register bank configuration, an efficient program can be created by switching between a register for normal processing and a register for interrupts for each bank.

Figure 3-21. Configuration of General-Purpose Registers

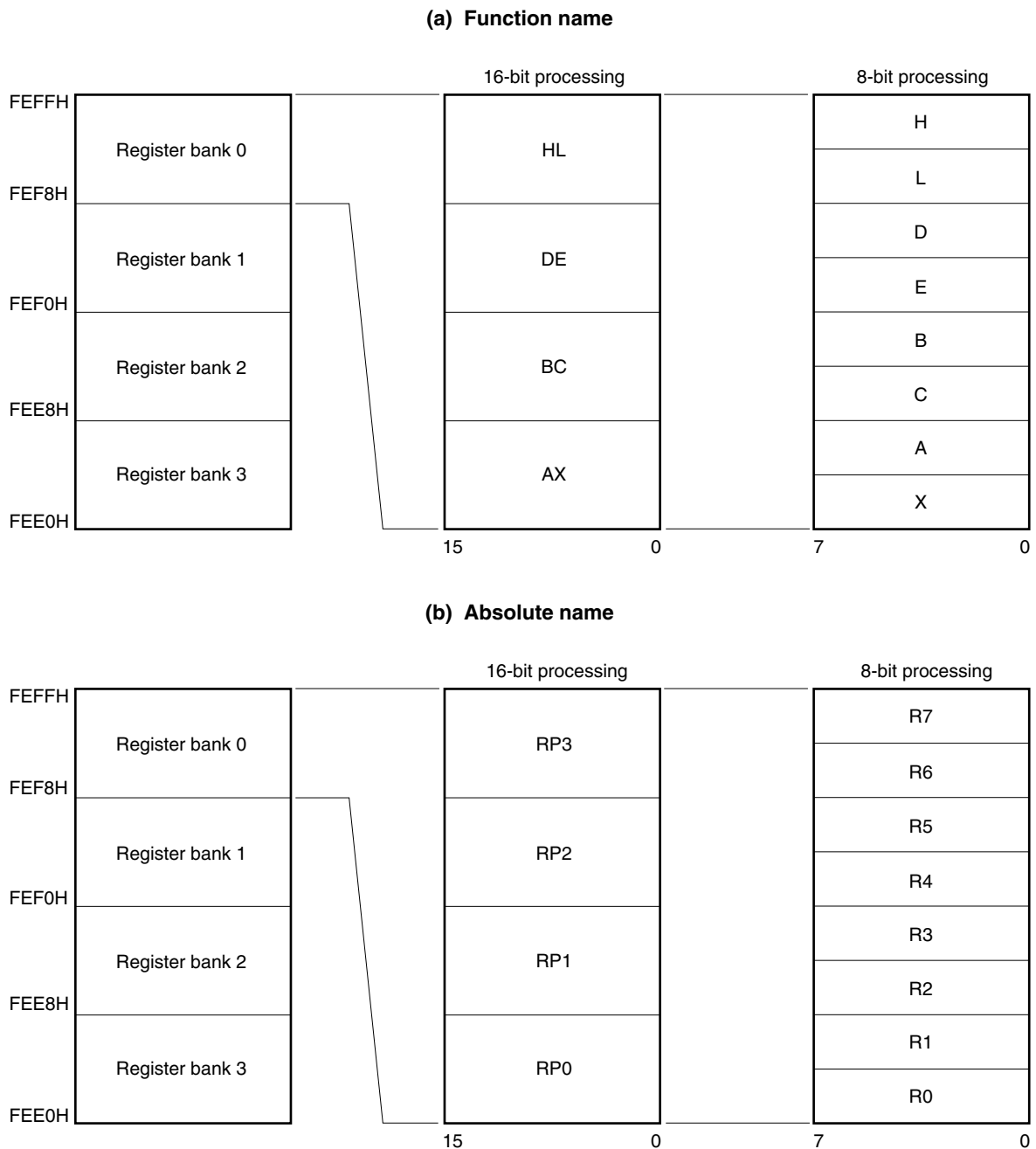

3.2.3 Special function registers (SFRs)

Unlike a general-purpose register, each special function register has a special function.

SFRs are allocated to the FF00H to FFFFH area.

Special function registers can be manipulated like general-purpose registers, using operation, transfer, and bit manipulation instructions. The manipulatable bit units, 1, 8, and 16, depend on the special function register type.

Each manipulation bit unit can be specified as follows.

- 1-bit manipulation
Describe the symbol reserved by the assembler for the 1-bit manipulation instruction operand (sfr.bit).
This manipulation can also be specified with an address.
- 8-bit manipulation
Describe the symbol reserved by the assembler for the 8-bit manipulation instruction operand (sfr).
This manipulation can also be specified with an address.
- 16-bit manipulation
Describe the symbol reserved by the assembler for the 16-bit manipulation instruction operand (sfrp).
When specifying an address, describe an even address.

Table 3-6 gives a list of the special function registers. The meanings of items in the table are as follows.

- Symbol
Symbol indicating the address of a special function register. It is a reserved word in the RA78K0, and is defined as an sfr variable using the #pragma sfr directive in the CC78K0. When using the RA78K0, ID78K0-QB, and SM+ for 78K0/KX2, symbols can be written as an instruction operand.
- R/W
Indicates whether the corresponding special function register can be read or written.
R/W: Read/write enable
R: Read only
W: Write only
- Manipulatable bit units
Indicates the manipulatable bit unit (1, 8, or 16). “–” indicates a bit unit for which manipulation is not possible.
- After reset
Indicates each register status upon reset signal generation.

Table 3-6. Special Function Register List (1/4)

Address	Special Function Register (SFR) Name	Symbol	R/W	Manipulatable Bit Unit			After Reset
				1 Bit	8 Bits	16 Bits	
FF00H	Port register 0	P0	R/W	√	√	–	00H
FF01H	Port register 1	P1	R/W	√	√	–	00H
FF02H	Port register 2	P2	R/W	√	√	–	00H
FF03H	Port register 3	P3	R/W	√	√	–	00H
FF04H	Port register 4	P4	R/W	√	√	–	00H
FF05H	Port register 5	P5	R/W	√	√	–	00H
FF06H	Port register 6	P6	R/W	√	√	–	00H
FF07H	Port register 7	P7	R/W	√	√	–	00H
FF08H	10-bit A/D conversion result register	ADCR	R	–	–	√	0000H
FF09H	8-bit A/D conversion result register	ADCRH	R	–	√	–	00H
FF0AH	Receive buffer register 6	RXB6	R	–	√	–	FFH
FF0BH	Transmit buffer register 6	TXB6	R/W	–	√	–	FFH
FF0CH	Port register 12	P12	R/W	√	√	–	00H
FF0DH	Port register 13	P13	R/W	√	√	–	00H
FF0EH	Port register 14	P14	R/W	√	√	–	00H
FF0FH	Serial I/O shift register 10	SIO10	R	–	√	–	00H
FF10H	16-bit timer counter 00	TM00	R	–	–	√	0000H
FF11H							
FF12H	16-bit timer capture/compare register 000	CR000	R/W	–	–	√	0000H
FF13H							
FF14H	16-bit timer capture/compare register 010	CR010	R/W	–	–	√	0000H
FF15H							
FF16H	8-bit timer counter 50	TM50	R	–	√	–	00H
FF17H	8-bit timer compare register 50	CR50	R/W	–	√	–	00H
FF18H	8-bit timer H compare register 00	CMP00	R/W	–	√	–	00H
FF19H	8-bit timer H compare register 10	CMP10	R/W	–	√	–	00H
FF1AH	8-bit timer H compare register 01	CMP01	R/W	–	√	–	00H
FF1BH	8-bit timer H compare register 11	CMP11	R/W	–	√	–	00H
FF1FH	8-bit timer counter 51	TM51	R	–	√	–	00H
FF20H	Port mode register 0	PM0	R/W	√	√	–	FFH
FF21H	Port mode register 1	PM1	R/W	√	√	–	FFH
FF22H	Port mode register 2	PM2	R/W	√	√	–	FFH
FF23H	Port mode register 3	PM3	R/W	√	√	–	FFH
FF24H	Port mode register 4	PM4	R/W	√	√	–	FFH
FF25H	Port mode register 5	PM5	R/W	√	√	–	FFH
FF26H	Port mode register 6	PM6	R/W	√	√	–	FFH
FF27H	Port mode register 7	PM7	R/W	√	√	–	FFH
FF28H	A/D converter mode register	ADM	R/W	√	√	–	00H
FF29H	Analog input channel specification register	ADS	R/W	√	√	–	00H
FF2CH	Port mode register 12	PM12	R/W	√	√	–	FFH
FF2EH	Port mode register 14	PM14	R/W	√	√	–	FFH
FF2FH	A/D port configuration register	ADPC	R/W	√	√	–	00H

Table 3-6. Special Function Register List (2/4)

Address	Special Function Register (SFR) Name	Symbol	R/W	Manipulatable Bit Unit			After Reset	
				1 Bit	8 Bits	16 Bits		
FF30H	Pull-up resistor option register 0	PU0	R/W	√	√	–	00H	
FF31H	Pull-up resistor option register 1	PU1	R/W	√	√	–	00H	
FF33H	Pull-up resistor option register 3	PU3	R/W	√	√	–	00H	
FF34H	Pull-up resistor option register 4	PU4	R/W	√	√	–	00H	
FF35H	Pull-up resistor option register 5	PU5	R/W	√	√	–	00H	
FF37H	Pull-up resistor option register 7	PU7	R/W	√	√	–	00H	
FF3CH	Pull-up resistor option register 12	PU12	R/W	√	√	–	00H	
FF3EH	Pull-up resistor option register 14	PU14	R/W	√	√	–	00H	
FF40H	Clock output selection register	CKS	R/W	√	√	–	00H	
FF41H	8-bit timer compare register 51	CR51	R/W	–	√	–	00H	
FF43H	8-bit timer mode control register 51	TMC51	R/W	√	√	–	00H	
FF48H	External interrupt rising edge enable register	EGP	R/W	√	√	–	00H	
FF49H	External interrupt falling edge enable register	EGN	R/W	√	√	–	00H	
FF4AH	Serial I/O shift register 11 ^{Note}	SIO11	R	–	√	–	00H	
FF4CH	Transmit buffer register 11 ^{Note}	SOTB11	R/W	–	√	–	00H	
FF4FH	Input switch control register	ISC	R/W	√	√	–	00H	
FF50H	Asynchronous serial interface operation mode register 6	ASIM6	R/W	√	√	–	01H	
FF53H	Asynchronous serial interface reception error status register 6	ASIS6	R	–	√	–	00H	
FF55H	Asynchronous serial interface transmission status register 6	ASIF6	R	–	√	–	00H	
FF56H	Clock selection register 6	CKSR6	R/W	–	√	–	00H	
FF57H	Baud rate generator control register 6	BRGC6	R/W	–	√	–	FFH	
FF58H	Asynchronous serial interface control register 6	ASICL6	R/W	√	√	–	16H	
FF60H	Remainder data register 0 ^{Note}	SDR0	SDR0L	R	–	√	√	00H
FF61H			SDR0H		–	√	–	00H
FF62H	Multiplication/division data register A0 ^{Note}	MDA0L	MDA0LL	R/W	–	√	√	00H
FF63H			MDA0LH		–	√	–	00H
FF64H		MDA0H	MDA0HL	R/W	–	√	√	00H
FF65H			MDA0HH		–	√	–	00H
FF66H	Multiplication/division data register B0 ^{Note}	MDB0L	MDB0L	R/W	–	√	√	00H
FF67H			MDB0H		–	√	–	00H
FF68H	Multiplier/divider control register 0 ^{Note}	DMUC0	R/W	√	√	–	00H	
FF69H	8-bit timer H mode register 0	TMHMD0	R/W	√	√	–	00H	
FF6AH	Timer clock selection register 50	TCL50	R/W	√	√	–	00H	
FF6BH	8-bit timer mode control register 50	TMC50	R/W	√	√	–	00H	
FF6CH	8-bit timer H mode register 1	TMHMD1	R/W	√	√	–	00H	
FF6DH	8-bit timer H carrier control register 1	TMCYC1	R/W	√	√	–	00H	
FF6EH	Key return mode register	KRM	R/W	√	√	–	00H	
FF6FH	Watch timer operation mode register	WTM	R/W	√	√	–	00H	

Note Available only in the μ PD78F0534, 78F0535, 78F0536, 78F0537, and 78F0537D.

Table 3-6. Special Function Register List (3/4)

Address	Special Function Register (SFR) Name	Symbol	R/W	Manipulatable Bit Unit			After Reset
				1 Bit	8 Bits	16 Bits	
FF70H	Asynchronous serial interface operation mode register 0	ASIM0	R/W	√	√	–	01H
FF71H	Baud rate generator control register 0	BRGC0	R/W	–	√	–	1FH
FF72H	Receive buffer register 0	RXB0	R	–	√	–	FFH
FF73H	Asynchronous serial interface reception error status register 0	ASIS0	R	–	√	–	00H
FF74H	Transmit shift register 0	TXS0	W	–	√	–	FFH
FF80H	Serial operation mode register 10	CSIM10	R/W	√	√	–	00H
FF81H	Serial clock selection register 10	CSIC10	R/W	√	√	–	00H
FF84H	Transmit buffer register 10	SOTB10	R/W	–	√	–	00H
FF88H	Serial operation mode register 11 ^{Note 1}	CSIM11	R/W	√	√	–	00H
FF89H	Serial clock selection register 11 ^{Note 1}	CSIC11	R/W	√	√	–	00H
FF8CH	Timer clock selection register 51	TCL51	R/W	√	√	–	00H
FF99H	Watchdog timer enable register	WDTE	R/W	–	√	–	^{Note 2} 1AH/9AH
FF9FH	Clock operation mode select register	OSCCTL	R/W	√	√	–	00H
FFA0H	Internal oscillation mode register	RCM	R/W	√	√	–	80H ^{Note 3}
FFA1H	Main clock mode register	MCM	R/W	√	√	–	00H
FFA2H	Main OSC control register	MOC	R/W	√	√	–	80H
FFA3H	Oscillation stabilization time counter status register	OSTC	R	√	√	–	00H
FFA4H	Oscillation stabilization time select register	OSTS	R/W	–	√	–	05H
FFA5H	IIC shift register 0	IIC0	R/W	–	√	–	00H
FFA6H	IIC control register 0	IICC0	R/W	√	√	–	00H
FFA7H	Slave address register 0	SVA0	R/W	–	√	–	00H
FFA8H	IIC clock selection register 0	IICCL0	R/W	√	√	–	00H
FFA9H	IIC function expansion register 0	IICX0	R/W	√	√	–	00H
FFAAH	IIC status register 0	IICS0	R	√	√	–	00H
FFABH	IIC flag register 0	IICF0	R/W	√	√	–	00H
FFACH	Reset control flag register	RESF	R	–	√	–	00H ^{Note 4}
FFB0H	16-bit timer counter 01 ^{Note 1}	TM01	R	–	–	√	0000H
FFB1H							
FFB2H	16-bit timer capture/compare register 001 ^{Note 1}	CR001	R/W	–	–	√	0000H
FFB3H							
FFB4H	16-bit timer capture/compare register 011 ^{Note 1}	CR011	R/W	–	–	√	0000H
FFB5H							
FFB6H	16-bit timer mode control register 01 ^{Note 1}	TMC01	R/W	√	√	–	00H
FFB7H	Prescaler mode register 01 ^{Note 1}	PRM01	R/W	√	√	–	00H
FFB8H	Capture/compare control register 01 ^{Note 1}	CRC01	R/W	√	√	–	00H
FFB9H	16-bit timer output control register 01 ^{Note 1}	TOC01	R/W	√	√	–	00H
FFBAH	16-bit timer mode control register 00	TMC00	R/W	√	√	–	00H

Notes 1. Available only in the μ PD78F0534, 78F0535, 78F0536, 78F0537, and 78F0537D.

2. The reset value of WDTE is determined by setting of option byte.

3. The value of this register is 00H immediately after a reset release but automatically changes to 80H after internal high-speed oscillator has been stabilized.

4. The reset value of RESF varies depending on the reset source.

Table 3-6. Special Function Register List (4/4)

Address	Special Function Register (SFR) Name	Symbol	R/W	Manipulatable Bit Unit			After Reset	
				1 Bit	8 Bits	16 Bits		
FFBBH	Prescaler mode register 00	PRM00	R/W	√	√	–	00H	
FFBCH	Capture/compare control register 00	CRC00	R/W	√	√	–	00H	
FFBDH	16-bit timer output control register 00	TOC00	R/W	√	√	–	00H	
FFBEH	Low-voltage detection register	LVIM	R/W	√	√	–	00H ^{Note 1}	
FFBFH	Low-voltage detection level selection register	LVIS	R/W	√	√	–	00H ^{Note 1}	
FFE0H	Interrupt request flag register 0L	IF0	IF0L	R/W	√	√	√	00H
FFE1H	Interrupt request flag register 0H		IF0H	R/W	√	√		00H
FFE2H	Interrupt request flag register 1L	IF1	IF1L	R/W	√	√	√	00H
FFE3H	Interrupt request flag register 1H		IF1H	R/W	√	√		00H
FFE4H	Interrupt mask flag register 0L	MK0	MK0L	R/W	√	√	√	FFH
FFE5H	Interrupt mask flag register 0H		MK0H	R/W	√	√		FFH
FFE6H	Interrupt mask flag register 1L	MK1	MK1L	R/W	√	√	√	FFH
FFE7H	Interrupt mask flag register 1H		MK1H	R/W	√	√		FFH
FFE8H	Priority specification flag register 0L	PR0	PR0L	R/W	√	√	√	FFH
FFE9H	Priority specification flag register 0H		PR0H	R/W	√	√		FFH
FFEAH	Priority specification flag register 1L	PR1	PR1L	R/W	√	√	√	FFH
FFEBH	Priority specification flag register 1H		PR1H	R/W	√	√		FFH
FFF0H	Internal memory size switching register ^{Note 2}	IMS		R/W	–	√	–	CFH
FFF3H	Memory bank select register	BANK		R/W	–	√	–	00H
FFF4H	Internal expansion RAM size switching register ^{Note 2}	IXS		R/W	–	√	–	0CH
FFFBH	Processor clock control register	PCC		R/W	√	√	–	01H

Notes 1. The reset values of LVIM and LVIS vary depending on the reset source.

- 2.** Regardless of the internal memory capacity, the initial values of the internal memory size switching register (IMS) and internal expansion RAM size switching register (IXS) of all products in the 78K0/KE2 are fixed (IMS = CFH, IXS = 0CH). Therefore, set the value corresponding to each product as indicated below.

Flash Memory Version (78K0/KE2)	IMS	IXS	ROM Capacity	Internal High-Speed RAM Capacity	Internal Expansion RAM Capacity
μPD78F0531	04H	0CH	16 KB	768 bytes	–
μPD78F0532	C6H		24 KB	1 KB	
μPD78F0533	C8H		32 KB		
μPD78F0534	CCH	0AH	48 KB	1 KB	1 KB
μPD78F0535	CFH	08H	60 KB		2 KB
μPD78F0536	CCH	04H	48 KB		4 KB
μPD78F0537, 78F0537D	CCH	00H	48 KB		6 KB

3.3 Instruction Address Addressing

- ★ An instruction address is determined by contents of the program counter (PC) and memory bank select register (BANK), and is normally incremented (+1 for each byte) automatically according to the number of bytes of an instruction to be fetched each time another instruction is executed. When a branch instruction is executed, the branch destination information is set to PC and branched by the following addressing (for details of instructions, refer to the **78K/0 Series Instructions User's Manual (U12326E)**).

3.3.1 Relative addressing

[Function]

The value obtained by adding 8-bit immediate data (displacement value: $jdisp8$) of an instruction code to the start address of the following instruction is transferred to the program counter (PC) and branched. The displacement value is treated as signed two's complement data (–128 to +127) and bit 7 becomes a sign bit. In other words, relative addressing consists of relative branching from the start address of the following instruction to the –128 to +127 range.

This function is carried out when the BR \$addr16 instruction or a conditional branch instruction is executed.

[Illustration]

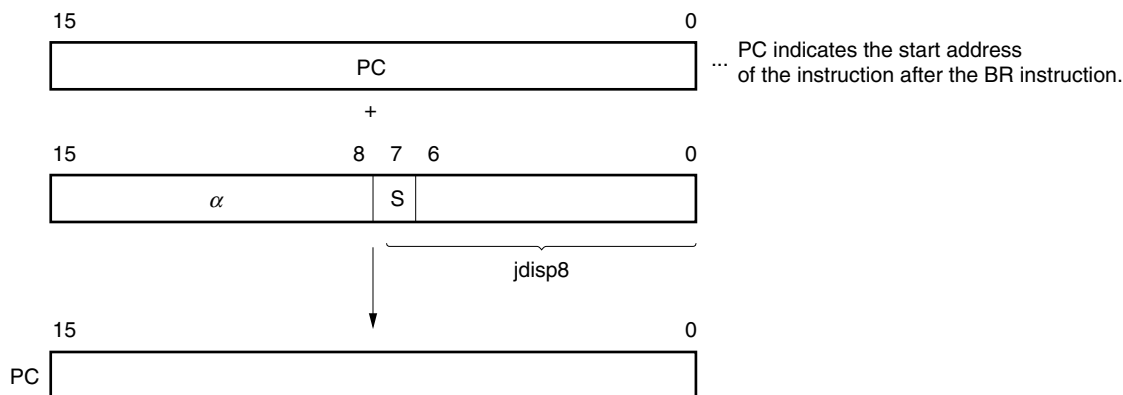

When $S = 0$, all bits of α are 0.
 When $S = 1$, all bits of α are 1.

3.3.2 Immediate addressing

[Function]

Immediate data in the instruction word is transferred to the program counter (PC) and branched.

This function is carried out when the CALL !addr16 or BR !addr16 or CALLF !addr11 instruction is executed.

- ★ CALL !addr16 and BR !addr16 instructions can be branched to the entire memory space. However, before branching to a memory bank that is not set by the memory bank select register (BANK), change the setting of the memory bank by using BANK.

The CALLF !addr11 instruction is branched to the 0800H to 0FFFH area.

[Illustration]

In the case of CALL !addr16 and BR !addr16 instructions

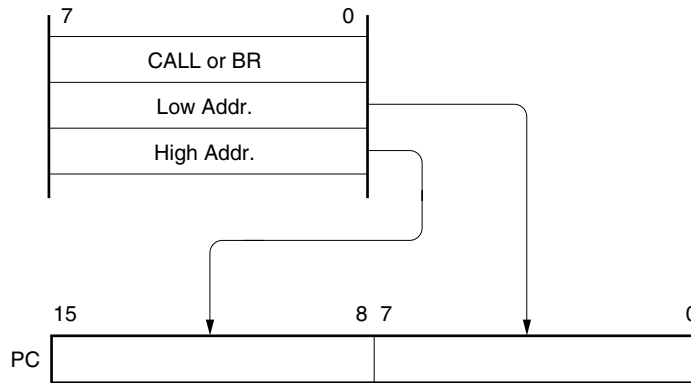

In the case of CALLF !addr11 instruction

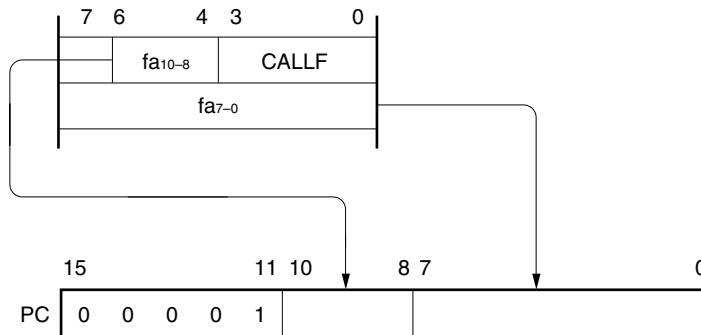

3.3.3 Table indirect addressing

[Function]

Table contents (branch destination address) of the particular location to be addressed by bits 1 to 5 of the immediate data of an operation code are transferred to the program counter (PC) and branched.

This function is carried out when the CALLT [addr5] instruction is executed.

★ This instruction references the address stored in the memory table from 40H to 7FH, and allows branching to the entire memory space. However, before branching to a memory bank that is not set by the memory bank select register (BANK), change the setting of the memory bank by using BANK.

[Illustration]

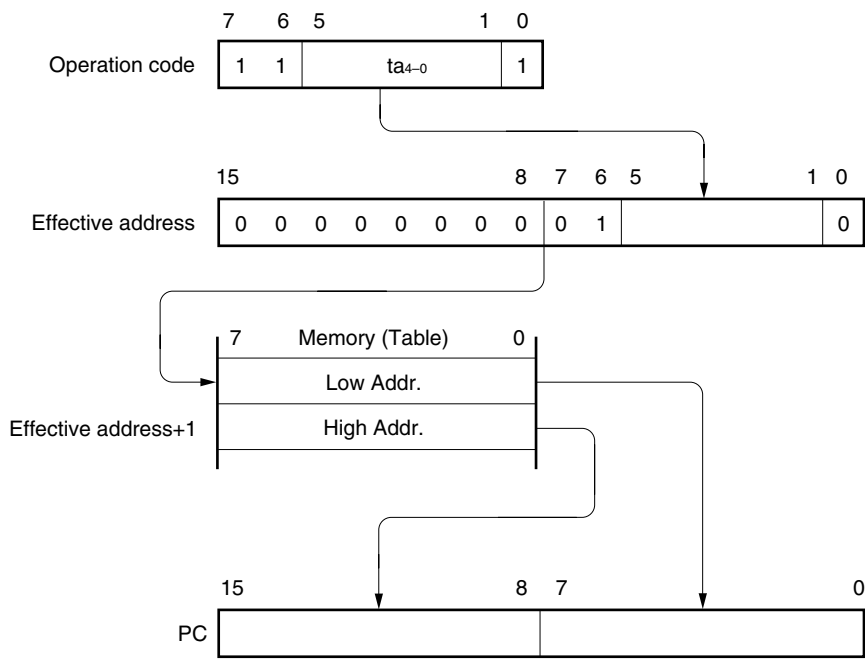

3.3.4 Register addressing

[Function]

Register pair (AX) contents to be specified with an instruction word are transferred to the program counter (PC) and branched.

This function is carried out when the BR AX instruction is executed.

[Illustration]

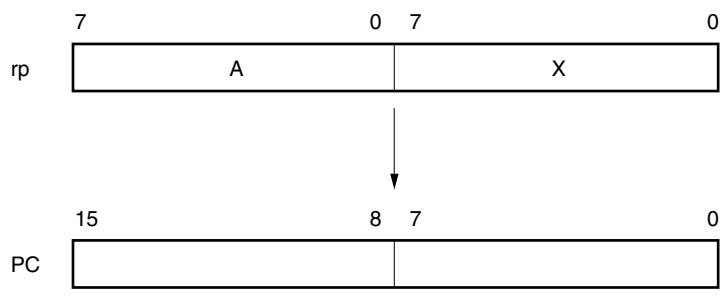

3.4 Operand Address Addressing

The following methods are available to specify the register and memory (addressing) to undergo manipulation during instruction execution.

3.4.1 Implied addressing

[Function]

The register that functions as an accumulator (A and AX) among the general-purpose registers is automatically (implicitly) addressed.

Of the 78K0/KE2 instruction words, the following instructions employ implied addressing.

Instruction	Register to Be Specified by Implied Addressing
MULU	A register for multiplicand and AX register for product storage
DIVUW	AX register for dividend and quotient storage
ADJBA/ADJBS	A register for storage of numeric values that become decimal correction targets
ROR4/ROL4	A register for storage of digit data that undergoes digit rotation

[Operand format]

Because implied addressing can be automatically determined with an instruction, no particular operand format is necessary.

[Description example]

In the case of MULU X

With an 8-bit \times 8-bit multiply instruction, the product of A register and X register is stored in AX. In this example, the A and AX registers are specified by implied addressing.

3.4.2 Register addressing

[Function]

The general-purpose register to be specified is accessed as an operand with the register bank select flags (RBS0 to RBS1) and the register specify codes of an operation code.

Register addressing is carried out when an instruction with the following operand format is executed. When an 8-bit register is specified, one of the eight registers is specified with 3 bits in the operation code.

[Operand format]

Identifier	Description
r	X, A, C, B, E, D, L, H
rp	AX, BC, DE, HL

'r' and 'rp' can be described by absolute names (R0 to R7 and RP0 to RP3) as well as function names (X, A, C, B, E, D, L, H, AX, BC, DE, and HL).

[Description example]

MOV A, C; when selecting C register as r

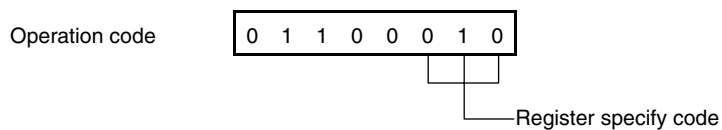

INCW DE; when selecting DE register pair as rp

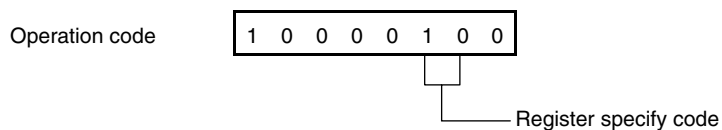

3.4.3 Direct addressing

[Function]

The memory to be manipulated is directly addressed with immediate data in an instruction word becoming an operand address.

- ★ This addressing can be carried out for all of the memory spaces. However, before addressing a memory bank that is not set by the memory bank select register (BANK), change the setting of the memory bank by using BANK.

[Operand format]

Identifier	Description
addr16	Label or 16-bit immediate data

[Description example]

MOV A, !0FE00H; when setting !addr16 to FE00H

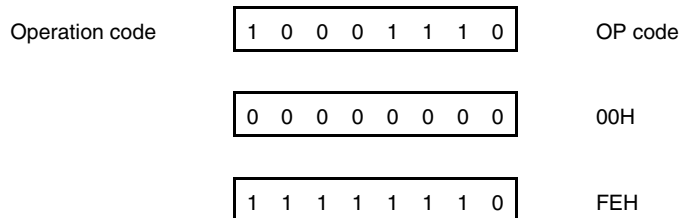

[Illustration]

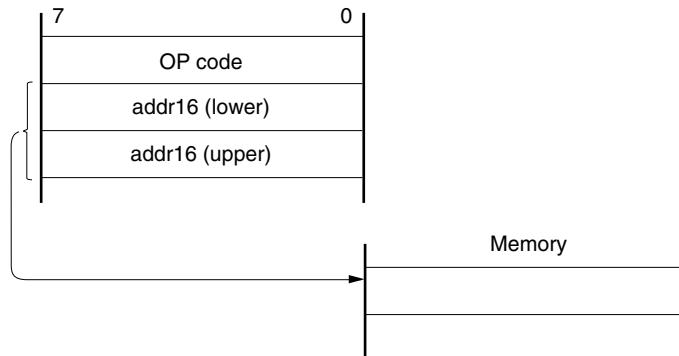

3.4.4 Short direct addressing

[Function]

The memory to be manipulated in the fixed space is directly addressed with 8-bit data in an instruction word. This addressing is applied to the 256-byte space FE20H to FF1FH. Internal high-speed RAM and special function registers (SFRs) are mapped at FE20H to FEFFH and FF00H to FF1FH, respectively. The SFR area (FF00H to FF1FH) where short direct addressing is applied is a part of the overall SFR area. Ports that are frequently accessed in a program and compare and capture registers of the timer/event counter are mapped in this area, allowing SFRs to be manipulated with a small number of bytes and clocks. When 8-bit immediate data is at 20H to FFH, bit 8 of an effective address is set to 0. When it is at 00H to 1FH, bit 8 is set to 1. See the **[Illustration]** shown below.

[Operand format]

Identifier	Description
saddr	Immediate data that indicate label or FE20H to FF1FH
saddrp	Immediate data that indicate label or FE20H to FF1FH (even address only)

★

[Description example]

LB1 EQU 0FE30H ; Defines FE30H by LB1.

:

MOV LB1, A ; When LB1 indicates FE30H of the saddr area and the value of register A is transferred to that address

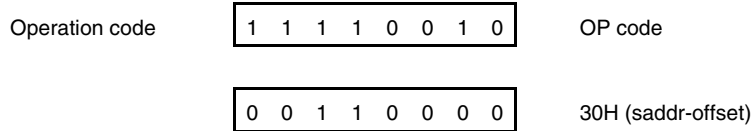

[Illustration]

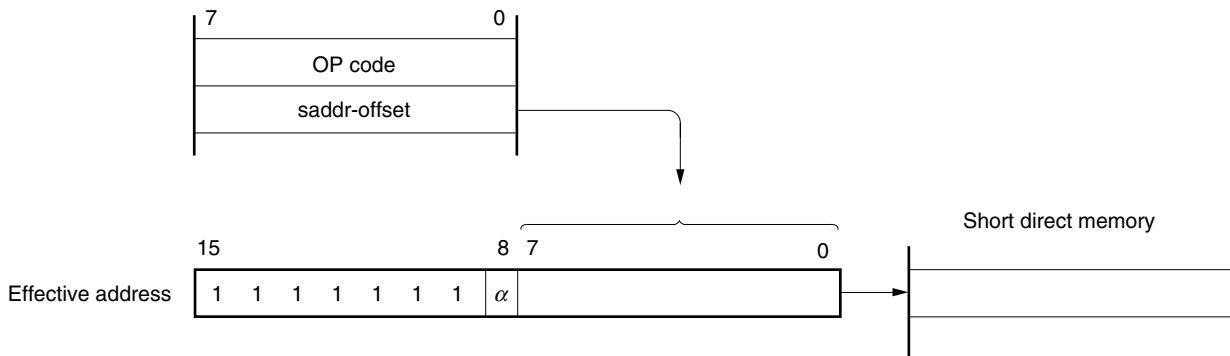

When 8-bit immediate data is 20H to FFH, $\alpha = 0$

When 8-bit immediate data is 00H to 1FH, $\alpha = 1$

3.4.5 Special function register (SFR) addressing

[Function]

A memory-mapped special function register (SFR) is addressed with 8-bit immediate data in an instruction word. This addressing is applied to the 240-byte spaces FF00H to FFCFH and FFE0H to FFFFH. However, the SFRs mapped at FF00H to FF1FH can be accessed with short direct addressing.

[Operand format]

Identifier	Description
sfr	Special function register name
sfrp	16-bit manipulatable special function register name (even address only)

[Description example]

MOV PM0, A; when selecting PM0 (FF20H) as sfr

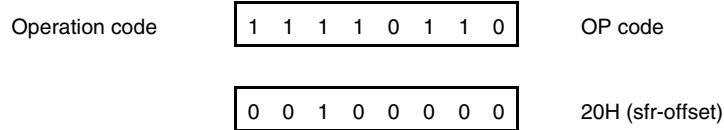

[Illustration]

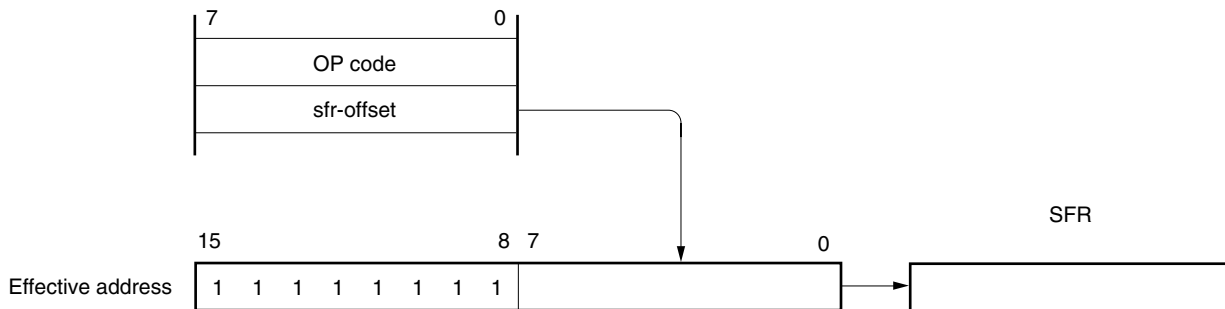

3.4.6 Register indirect addressing

[Function]

Register pair contents specified by a register pair specify code in an instruction word and by a register bank select flag (RBS0 and RBS1) serve as an operand address for addressing the memory.

★ This addressing can be carried out for all of the memory spaces. However, before addressing a memory bank that is not set by the memory bank select register (BANK), change the setting of the memory bank by using BANK.

[Operand format]

Identifier	Description
-	[DE], [HL]

[Description example]

MOV A, [DE]; when selecting [DE] as register pair

Operation code 1 0 0 0 0 1 0 1

[Illustration]

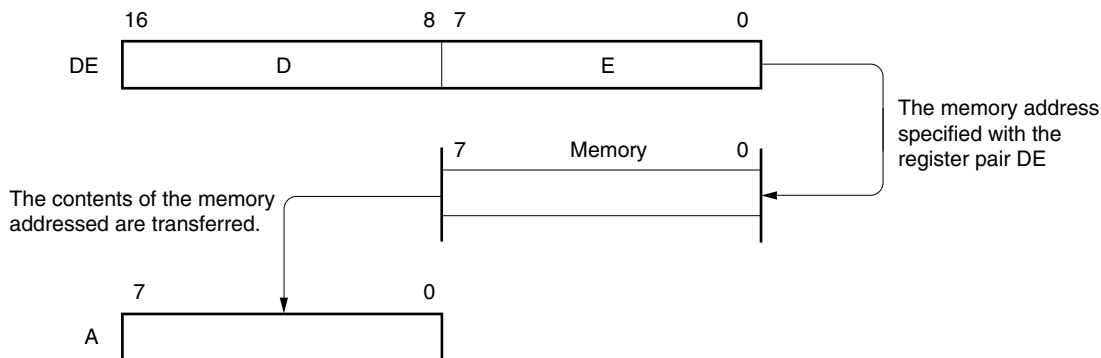

3.4.7 Based addressing

[Function]

8-bit immediate data is added as offset data to the contents of the base register, that is, the HL register pair in the register bank specified by the register bank select flag (RBS0 and RBS1), and the sum is used to address the memory. Addition is performed by expanding the offset data as a positive number to 16 bits. A carry from the 16th bit is ignored.

- ★ This addressing can be carried out for all of the memory spaces. However, before addressing a memory bank that is not set by the memory bank select register (BANK), change the setting of the memory bank by using BANK.

[Operand format]

Identifier	Description
–	[HL + byte]

[Description example]

MOV A, [HL + 10H]; when setting byte to 10H

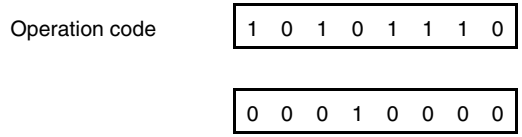

[Illustration]

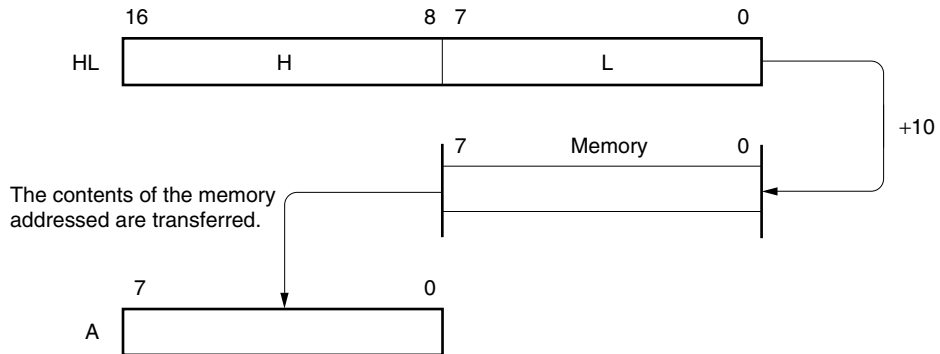

3.4.8 Based indexed addressing

[Function]

The B or C register contents specified in an instruction word are added to the contents of the base register, that is, the HL register pair in the register bank specified by the register bank select flag (RBS0 and RBS1), and the sum is used to address the memory. Addition is performed by expanding the B or C register contents as a positive number to 16 bits. A carry from the 16th bit is ignored.

★ This addressing can be carried out for all of the memory spaces. However, before addressing a memory bank that is not set by the memory bank select register (BANK), change the setting of the memory bank by using BANK.

[Operand format]

Identifier	Description
-	[HL + B], [HL + C]

[Description example]

MOV A, [HL +B]; when selecting B register



[Illustration]

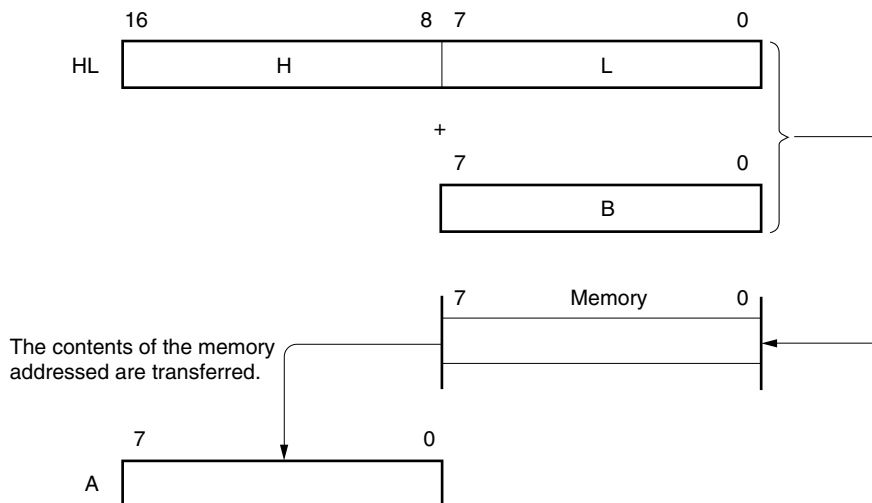

3.4.9 Stack addressing

[Function]

The stack area is indirectly addressed with the stack pointer (SP) contents.

This addressing method is automatically employed when the PUSH, POP, subroutine call and return instructions are executed or the register is saved/reset upon generation of an interrupt request.

With stack addressing, only the internal high-speed RAM area can be accessed.

[Description example]

PUSH DE; when saving DE register

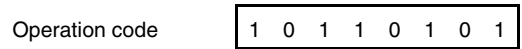

[Illustration]

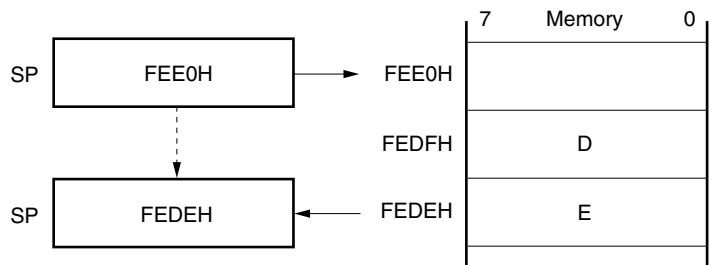

★

CHAPTER 4 MEMORY BANK SELECT FUNCTION (μ PD78F0536, 78F0537, AND 78F0537D ONLY)

4.1 Memory Bank

The μ PD78F0536, 78F0537, and 78F0537D implement a ROM capacity of 96 KB or 128 KB by selecting a memory bank from a memory space of 8000H to BFFFH.

The μ PD78F0536 has memory banks 0 to 3, and the μ PD78F0537 and 78F0537D have memory banks 0 to 5, as shown below.

The memory banks are selected by using a memory bank select register (BANK).

Figure 4-1. Internal ROM (Flash Memory) Configuration

(a) μ PD78F0536

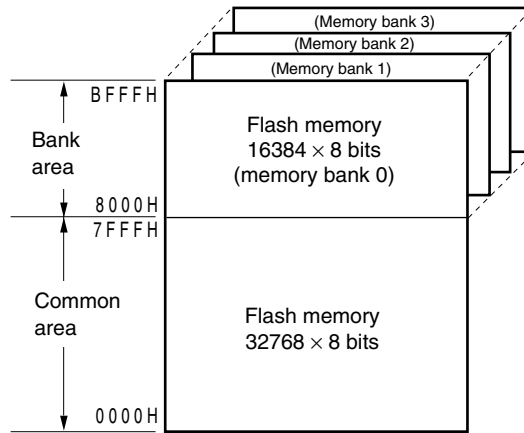

(b) μ PD78F0537, 78F0537D

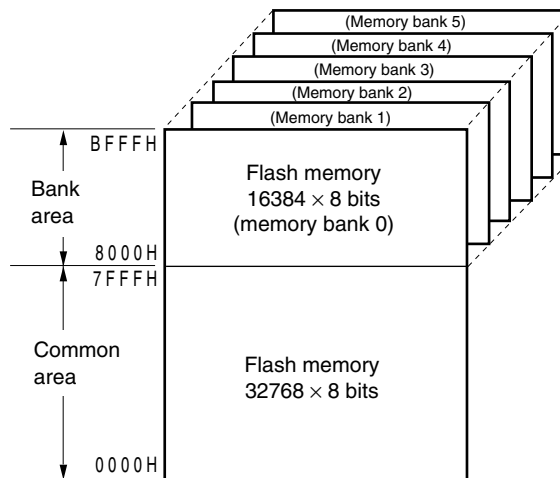

4.2 Memory Bank Select Register (BANK)

The memory bank select register (BANK) is used to select a memory bank to be used.

BANK can be set by an 8-bit memory manipulation instruction.

Reset signal generation clears BANK to 00H.

Figure 4-2. Format of Memory Bank Select Register (BANK)

Address: FFF3H After reset: 00H R/W

Symbol	7	6	5	4	3	2	1	0
BANK	0	0	0	0	0	BANK2	BANK1	BANK0

BANK2	BANK1	BANK0	Bank setting	
			μ PD78F0536	μ PD78F0537, 78F0537D
0	0	0	Common area (32 K) + memory bank 0 (16 K)	
0	0	1	Common area (32 K) + memory bank 1 (16 K)	
0	1	0	Common area (32 K) + memory bank 2 (16 K)	
0	1	1	Common area (32 K) + memory bank 3 (16 K)	
1	0	0	Setting prohibited	Common area (32 K) + memory bank 4 (16 K)
1	0	1		Common area (32 K) + memory bank 5 (16 K)
Other than above			Setting prohibited	

Caution Be sure to change the value of the BANK register in the common area (0000H to 7FFFH). If the value of the BANK register is changed in the bank area (8000H to BFFFH), an inadvertent program loop occurs in the CPU. Therefore, never change the value of the BANK register in the bank area.

4.3 Selecting Memory Bank

The memory bank selected by the memory bank select register (BANK) is reflected on the bank area and can be addressed. Therefore, to access a memory bank different from the one currently selected, that memory bank must be selected by using the BANK register.

The value of the BANK register must not be changed in the bank area (8000H to BFFFH). Therefore, to change the memory bank, branch an instruction to the common area (0000H to 7FFFH) and change the value of the BANK register in that area.

- Cautions**
1. Instructions cannot be fetched between different memory banks.
 2. Branching and accessing cannot be directly executed between different memory banks. Execute branching or accessing between different memory banks via the common area.
 3. Allocate interrupt servicing in the common area.
 4. An instruction that extends from 7FFFH to 8000H can only be executed in memory bank 0.

4.3.1 Referencing values between memory banks

Values cannot be directly referenced from one memory bank to another.

To access another memory bank from one memory bank, branch once to the common area (0000H to 7FFFH), change the setting of the BANK register there, and then reference a value.

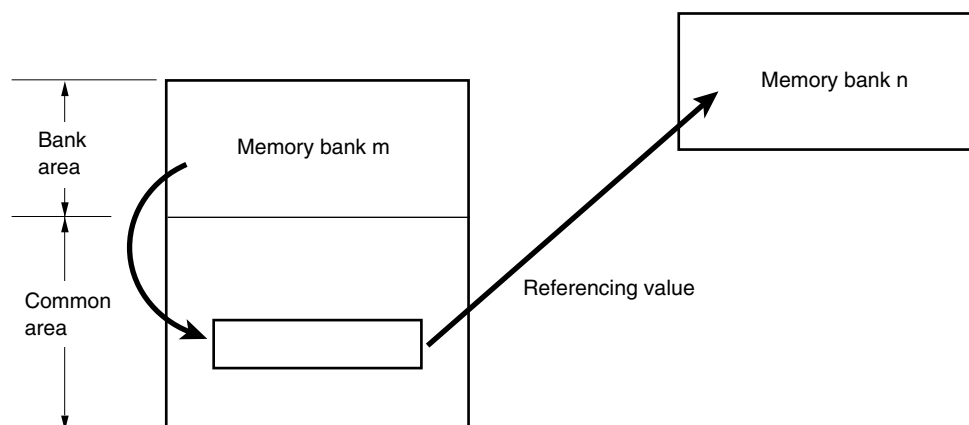
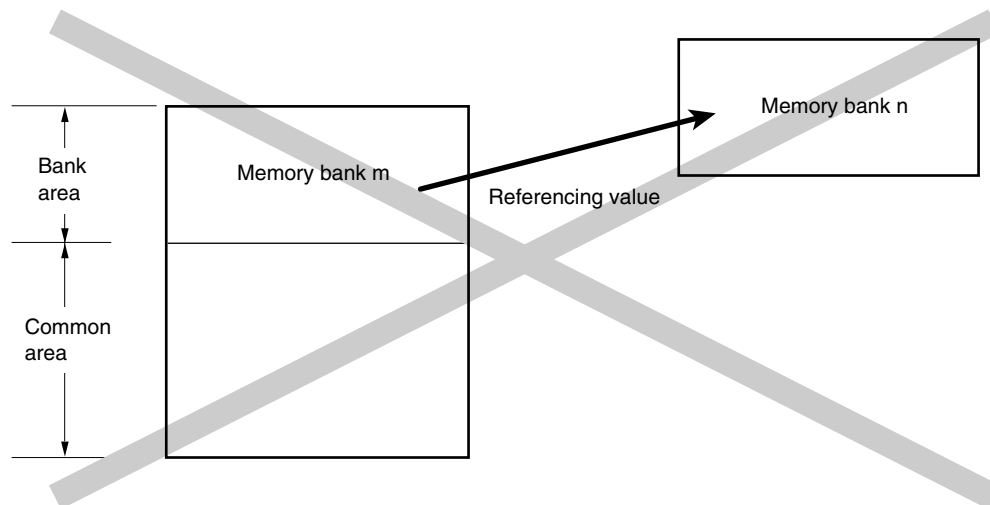

4.3.2 Branching instruction between memory banks

Instructions cannot branch directly from one memory bank to another.

To branch an instruction from one memory bank to another, branch once to the common area (0000H to 7FFFH), change the setting of the BANK register there, and then execute the branch instruction again.

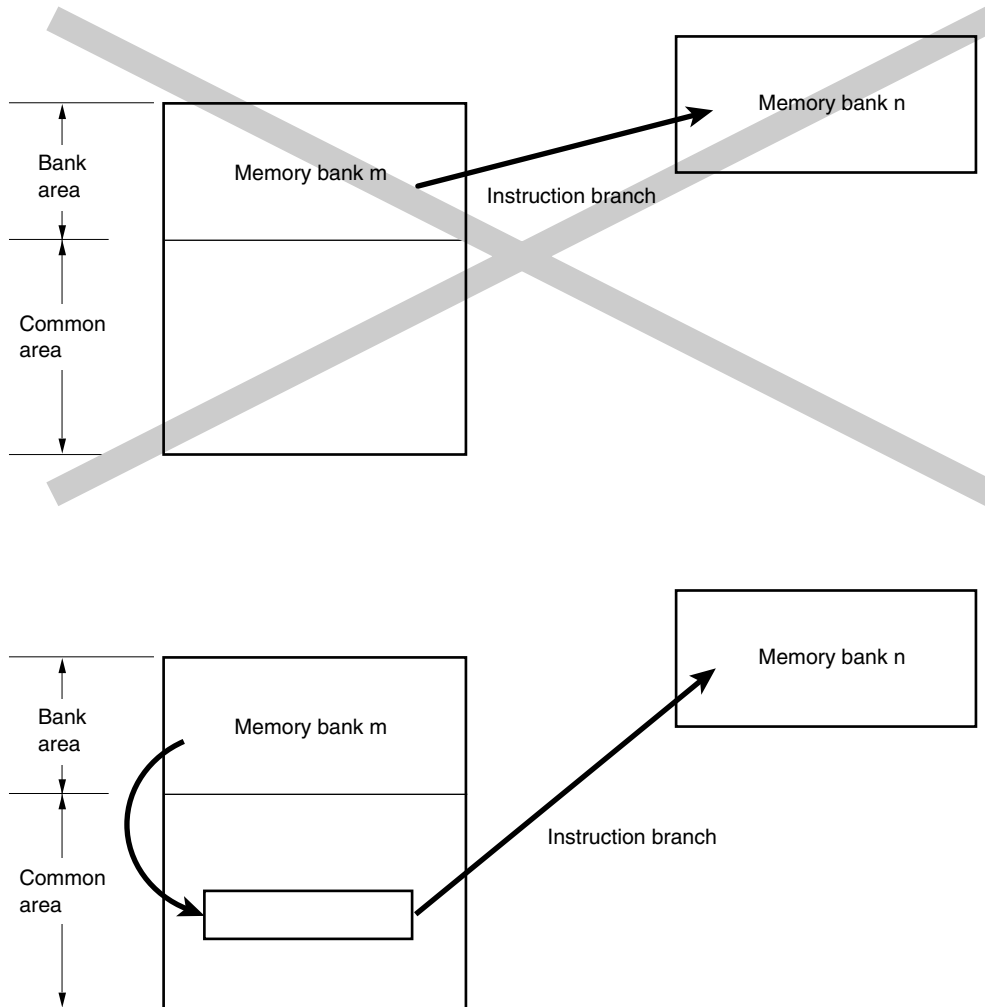

- Software example

```

RAMD   DSEG   SADDR
R_BNKA: DS    2                ; Secures RAM for specifying a memory bank at the branch destination.
R_BNKN: DS    1                ; Secures RAM for specifying a memory bank number at the branch destination.

-----

      MOV     R_BNKN,#BANKNUM TEST ; Stores the memory bank number at the branch destination in RAM.
      MOVW   R_BNKA,#TEST          ; Stores the address at the branch destination in RAM.
      BR     !BNKBR                ; Branches to inter-memory bank branch processing.
      :
      :

-----

BNKC   CSEG   AT      7000H      ;
BNKBR:
      MOV     A,R_BNKN           ;
      MOV     BANK,A             ; Specifies the memory bank number at the branch destination.
      MOVW   AX,R_BNKA          ; Specifies the address at the branch destination.
      BR     AX                  ; Branch

-----

BN3    CSEG   BANK3
TEST:
      MOV ...
      :
      :
END

```

Remark In the software example above, the AX register is destructed.

4.3.3 Subroutine call between memory banks

Subroutines cannot be directly called between memory banks.

To call a subroutine between memory banks, branch once to the common area (0000H to 7FFFH), specify the memory bank at the calling destination by using the BANK register there, execute the CALL instruction, and branch to the call destination by that instruction.

At this time, save the current value of the BANK register to RAM. Restore the value of the BANK register before executing the RET instruction.

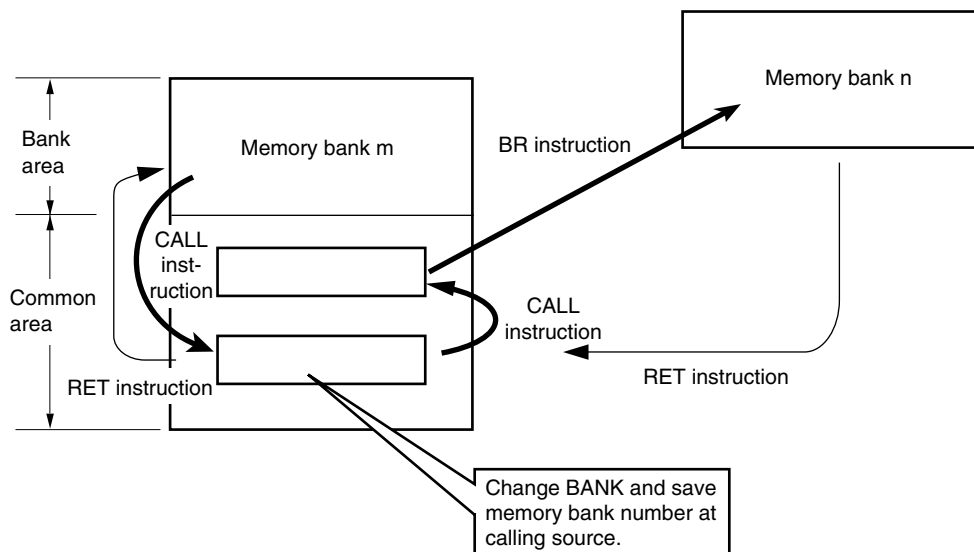
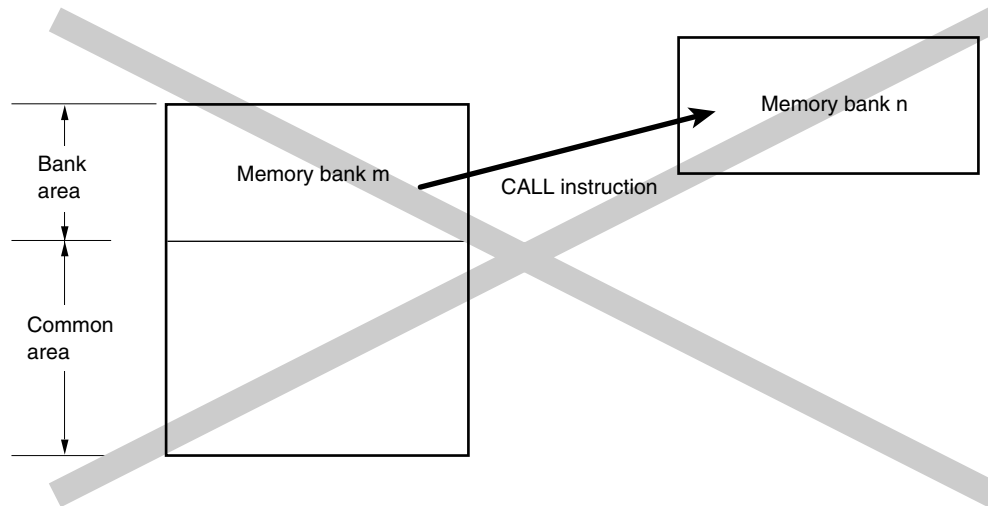

• Software example

```

RAMD   DSEG   SADDR
R_BNKA: DS    2                ; Secures RAM for specifying an address at the calling destination.
R_BNKN: DS    1                ; Secures RAM for specifying a memory bank number at the calling destination.
R_BNKRN: DS   1                ; Secures RAM for saving a memory bank number at the calling source.

-----

      MOV     R_BNKN,#BANKNUM TEST ; Store the memory bank number at the calling destination in RAM.
      MOVW   R_BNKA,#TEST          ; Stores the address at the calling destination in RAM.
      CALL  !BNKCAL                ; Branches to an inter-memory bank calling processing routine.
      :
      :

-----

BNKC   CSEG   AT      7000H
BNKCAL:
      MOV     A,R_BNKN             ; Acquires the memory bank number at the calling destination.
      XCH    A,BANK               ; Changes the bank and acquires the memory bank number at the calling source.
      MOV     R_BNKRN,A           ; Saves the memory bank number at the calling source to RAM.
      CALL  !BNKCAL              ; Calls a subroutine to branch to the calling destination.
      XCH    A,R_BNKRN           ;
      MOV     BANK,A             ; Specifies the memory bank number at the calling source.
      RET                               ; Returns to the calling source.

BNKCAL:
      MOVW   AX,R_BNKA            ; Specifies the address at the calling destination.
      BR     AX                   ; Branches to the calling destination.

-----

BN3    CSEG   BANK3
TEST:
      MOV ...
      :
      :
      RET
END

```

Remark In the software example above, the AX register is destructed. Multiplexed processing is not supported.

4.3.4 Instruction branch to bank area by interrupt

When an interrupt occurs, instructions can branch to the memory bank specified by the BANK register by using the vector table, but it is difficult to identify the BANK register when the interrupt occurs.

Therefore, specify the branch destination address specified by the vector table in the common area (0000H to 7FFFH), specify the memory bank at the branch destination by using the BANK register in the common area, and execute the CALL instruction. At this time, save the BANK register value before the change to RAM, and restore the value of the BANK register before executing the RETI instruction.

Remark Allocate interrupt servicing that requires a quick response in the common area.

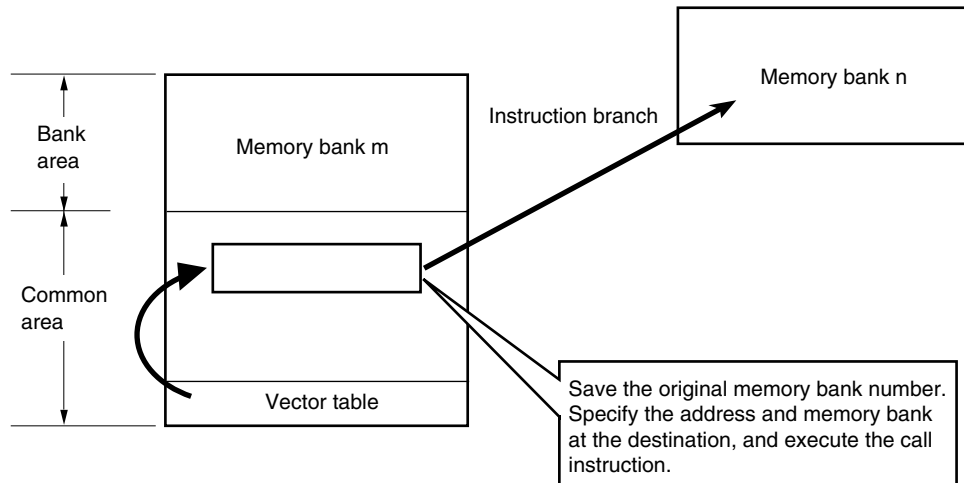

- Software example (when using interrupt request of 16-bit timer/event counter 00)

```

VCTBL  CSEG  AT    0020H
        DW    BNKITM000          ; Specifies an address at the timer interrupt destination.

RAMD   DSEG  SADDR
R_BNKRN: DS    1                ; Secures RAM for saving the memory bank number before the interrupt occurs.

-----
BNKC   CSEG  AT    7000H

BNKITM000:
        PUSH  AX                ; Inter-memory bank interrupt servicing routine
                                   ; Saves the contents of the AX register.

        MOV   A,BANK
        MOV   R_BNKRN,A         ; Saves the memory bank number before the interrupt to RAM.
        MOV   BANK,#BANKNUM TEST ; Specifies the memory bank number of the interrupt routine.
        CALL  !TEST             ; Calls the interrupt routine.
        MOV   A,R_BNKRN        ; Restores the memory bank number before the interrupt.
        MOV   BANK,A

        POP   AX                ; Restores the contents of the AX register.

        RETI

-----
BN3    CSEG  BANK3
TEST:  ; Interrupt servicing routine
        MOV ...
        :
        :
        RET

END
    
```

Remark Note the following points to use the memory bank select function efficiently.

- Allocate a routine that is used often in the common area.
- If a value that is planned to be referenced is placed in RAM, it can be referenced from all of the areas.
- If the reference destination and the branch destination of the routine placed in a memory bank are placed in the same memory bank, then the code size and processing are more efficient.
- Allocate interrupt servicing that requires a quick response in the common area.

CHAPTER 5 PORT FUNCTIONS

5.1 Port Functions

There are three types of pin I/O buffer power supplies: AV_{REF} , EV_{DD} , and V_{DD} . The relationship between these power supplies and the pins is shown below.

★

Table 5-1. Pin I/O Buffer Power Supplies

Power Supply	Corresponding Pins
AV_{REF}	P20 to P27
EV_{DD}	Port pins other than P20 to P27 and P121 to P124
V_{DD}	<ul style="list-style-type: none"> • P121 to P124 • Non-port pins

78K0/KE2 products are provided with the ports shown in Figure 5-1, which enable variety of control operations. The functions of each port are shown in Table 5-2.

In addition to the function as digital I/O ports, these ports have several alternate functions. For details of the alternate functions, see **CHAPTER 2 PIN FUNCTIONS**.

Figure 5-1. Port Types

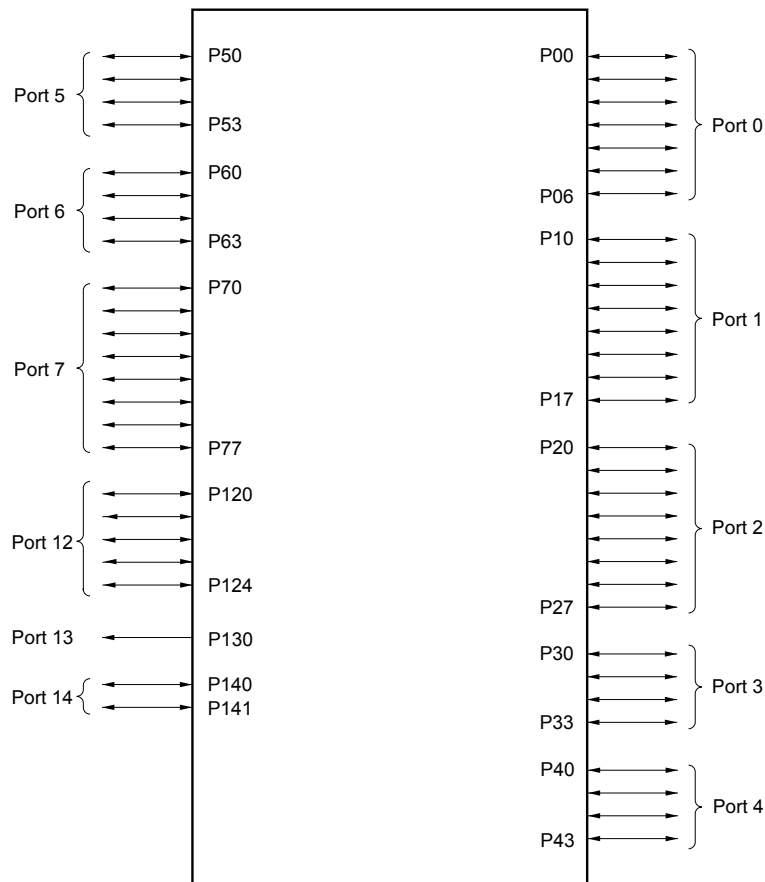

Table 5-2. Port Functions (1/2)

Pin Name	I/O	Function	After Reset	Alternate Function
P00	I/O	Port 0. 7-bit I/O port. Input/output can be specified in 1-bit units. Use of an on-chip pull-up resistor can be specified by a software setting.	Input port	TI000
P01				TI010/TO00
P02				SO11 ^{Note1}
P03				SI11 ^{Note1}
P04				SCK11 ^{Note1}
P05				SSI11 ^{Note1} /TI001 ^{Note1}
P06				TI011 ^{Note1} /TO01 ^{Note1}
P10	I/O	Port 1. 8-bit I/O port. Input/output can be specified in 1-bit units. Use of an on-chip pull-up resistor can be specified by a software setting.	Input port	SCK10/TxD0
P11				SI10/RxD0
P12				SO10
P13				TxD6
P14				RxD6
P15				TOH0
P16				TOH1/INTP5
P17				TI50/TO50
P20 to P27	I/O	Port 2. 8-bit I/O port. Input/output can be specified in 1-bit units.	Analog input	ANI0 to ANI7
P30	I/O	Port 3. 4-bit I/O port. Input/output can be specified in 1-bit units. Use of an on-chip pull-up resistor can be specified by a software setting.	Input port	INTP1
P31				INTP2/OCD1A ^{Note2}
P32				INTP3/OCD1B ^{Note2}
P33				INTP4/TI51/TO51
P40 to P43	I/O	Port 4. 4-bit I/O port. Input/output can be specified in 1-bit units. Use of an on-chip pull-up resistor can be specified by a software setting.	Input port	–
P50 to P53	I/O	Port 5. 4-bit I/O port. Input/output can be specified in 1-bit units. Use of an on-chip pull-up resistor can be specified by a software setting.	Input port	–
P60	I/O	Port 6. 4-bit I/O port (N-ch open drain). Input/output can be specified in 1-bit units.	Input port	SCL0
P61				SDA0
P62				EXSCL0
P63				–
P70 to P77	I/O	Port 7. 8-bit I/O port. Input/output can be specified in 1-bit units. Use of an on-chip pull-up resistor can be specified by a software setting.	Input port	KR0 to KR7

Notes 1. Available only in the μ PD78F0534, 78F0535, 78F0536, 78F0537, and 78F0537D.

★ **2.** μ PD78F0537D only

Table 5-2. Port Functions (2/2)

Function Name	I/O	Function	After Reset	Alternate Function
P120	I/O	Port 12. 5-bit I/O port. Input/output can be specified in 1-bit units. Only for P120, use of an on-chip pull-up resistor can be specified by a software setting.	Input port	INTP0/EXLVI
P121				X1/OCDOA ^{Note}
P122				X2/EXCLK/OCDOB ^{Note}
P123				XT1
P124				XT2/EXCLKS
P130	Output	Port 13. 1-bit output-only port.	Output port	–
P140	I/O	Port 14. 2-bit I/O port. Input/output can be specified in 1-bit units. Use of an on-chip pull-up resistor can be specified by a software setting.	Input port	PCL/INTP6
P141				BUZ/INTP7

Note μ PD78F0537D only

5.2 Port Configuration

Ports include the following hardware.

Table 5-3. Port Configuration

Item	Configuration
Control registers	Port mode register (PM0 to PM7, PM12, PM14) Port register (P0 to P7, P12 to P14) Pull-up resistor option register (PU0, PU1, PU3 to PU7, PU12, PU14) A/D port configuration register (ADPC)
Port	Total: 55 (CMOS I/O: 50, CMOS output: 1, N-ch open drain I/O: 4)
Pull-up resistor	Total: 38

5.2.1 Port 0

Port 0 is a 7-bit I/O port with an output latch. Port 0 can be set to the input mode or output mode in 1-bit units using port mode register 0 (PM0). When the P00 to P06 pins are used as an input port, use of an on-chip pull-up resistor can be specified in 1-bit units by pull-up resistor option register 0 (PU0).

This port can also be used for timer I/O, serial interface data I/O, clock I/O, and chip select input.

Reset signal generation sets port 0 to input mode.

Figures 5-2 to 5-7 show block diagrams of port 0.

- ★ **Caution** To use P02/SO11^{Note} and P04/SCK11^{Note} as general-purpose ports, set serial operation mode register 11 (CSIM11) and serial clock selection register 11 (CSIC11) to the default status (00H).

Note Available only in the μ PD78F0534, 78F0535, 78F0536, 78F0537, and 78F0537D.

Figure 5-2. Block Diagram of P00

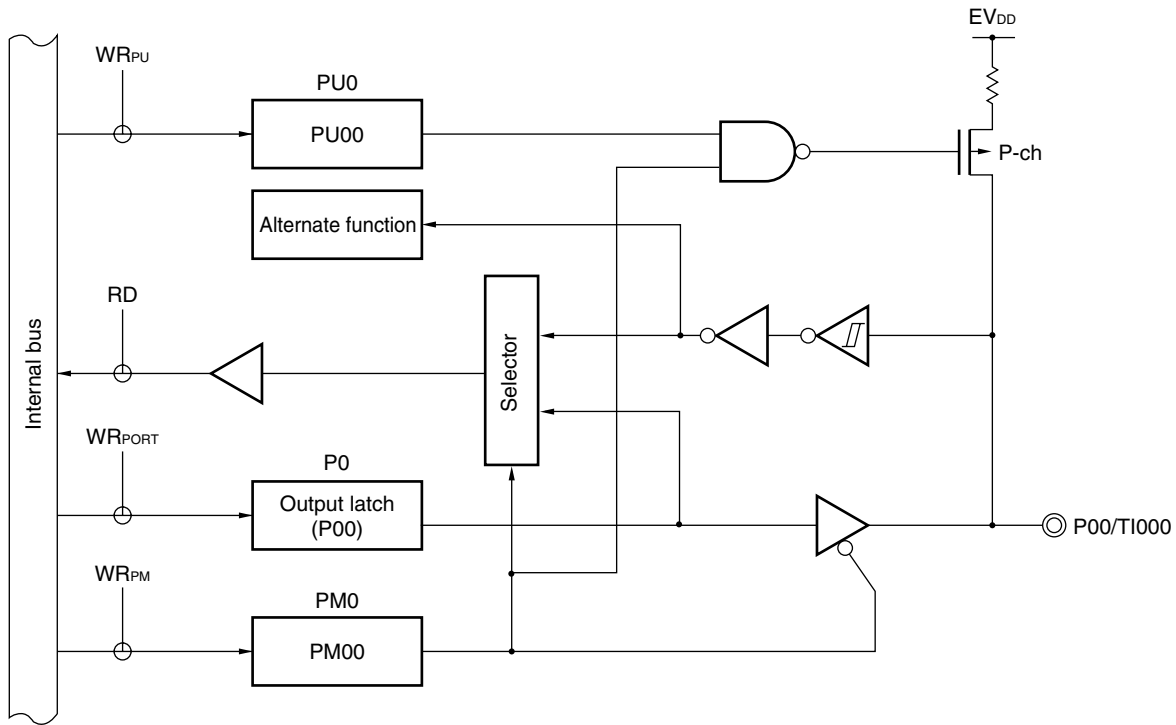

- P0: Port register 0
- PU0: Pull-up resistor option register 0
- PM0: Port mode register 0
- RD: Read signal
- WR_{xx}: Write signal

★

Figure 5-3. Block Diagram of P01

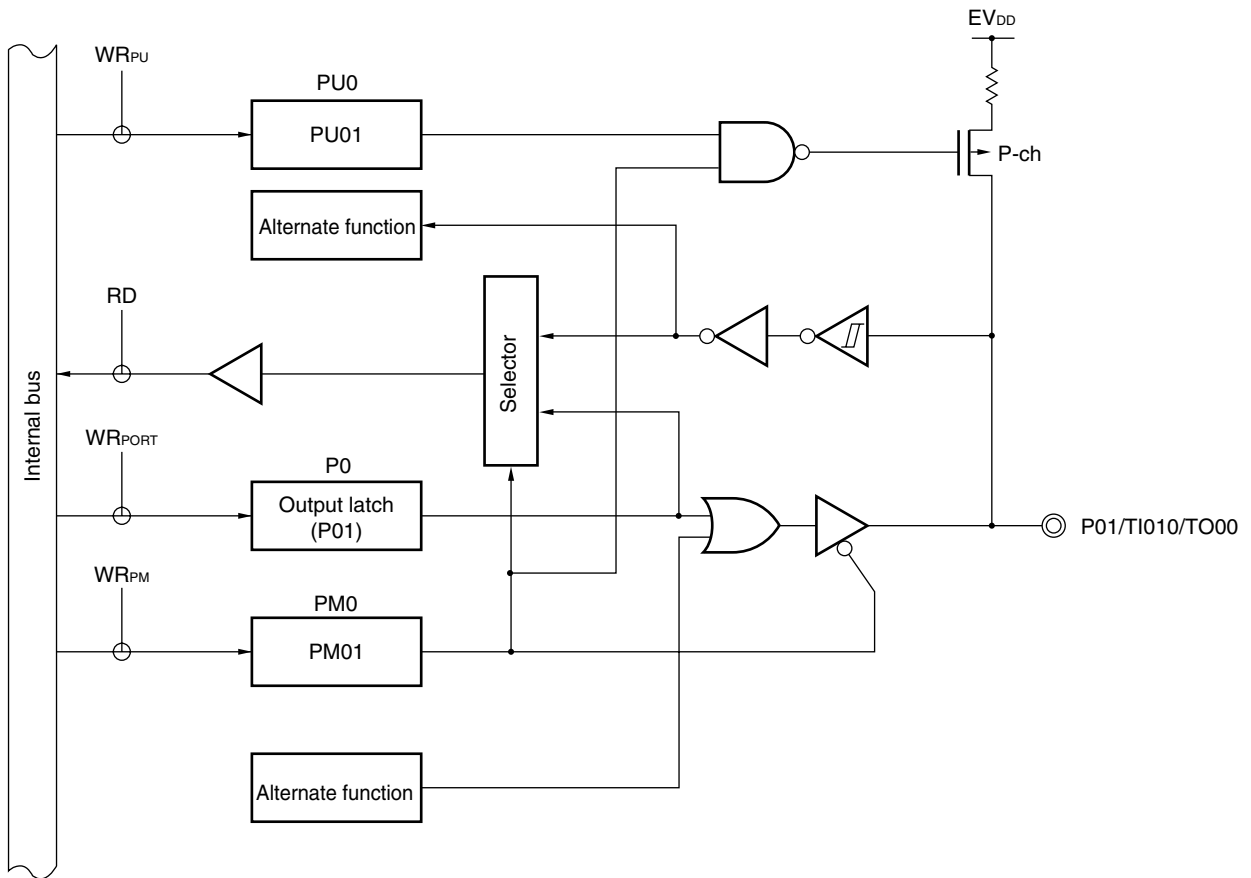

- P0: Port register 0
- PU0: Pull-up resistor option register 0
- PM0: Port mode register 0
- RD: Read signal
- WR_{xx}: Write signal

★

Figure 5-4. Block Diagram of P02

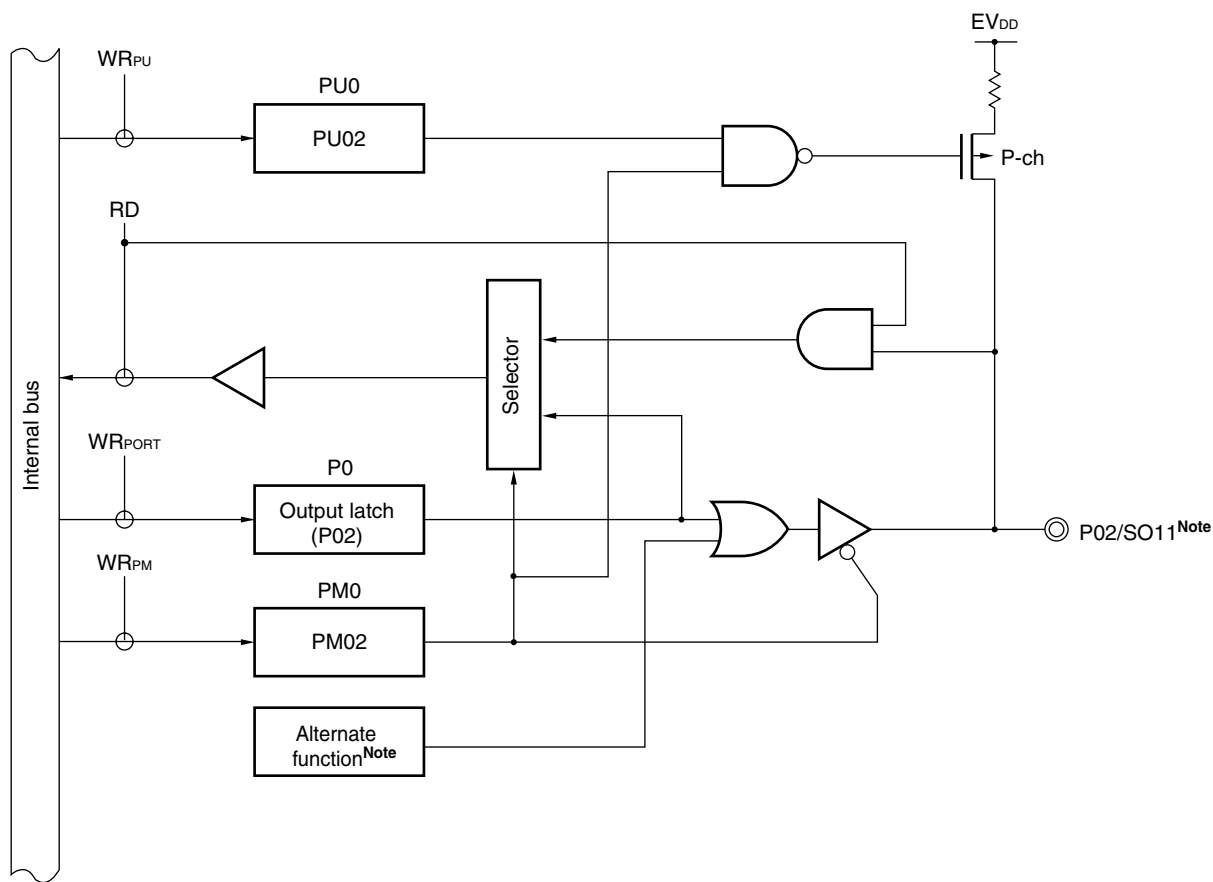

- P0: Port register 0
- PU0: Pull-up resistor option register 0
- PM0: Port mode register 0
- RD: Read signal
- WR_{xx}: Write signal

Note Available only in the μ PD78F0534, 78F0535, 78F0536, 78F0537, and 78F0537D.

★

Figure 5-5. Block Diagram of P03 and P05

(a) μ PD78F0531, 78F0532, 78F0533

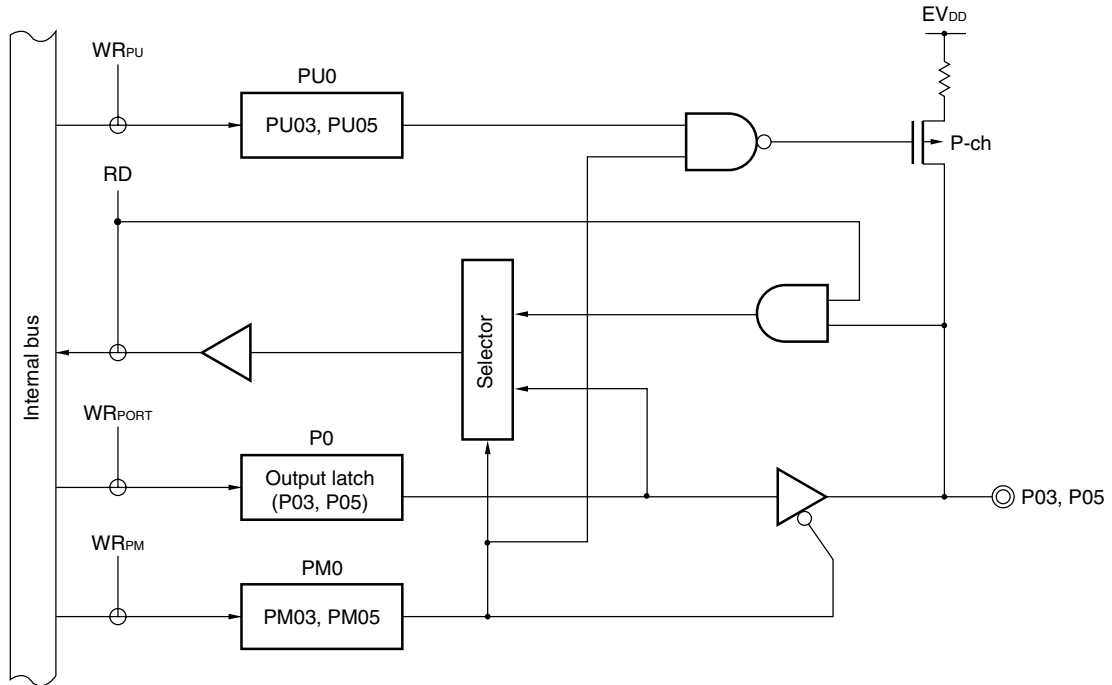

(b) μ PD78F0534, 78F0535, 78F0536, 78F0537, 78F0537D

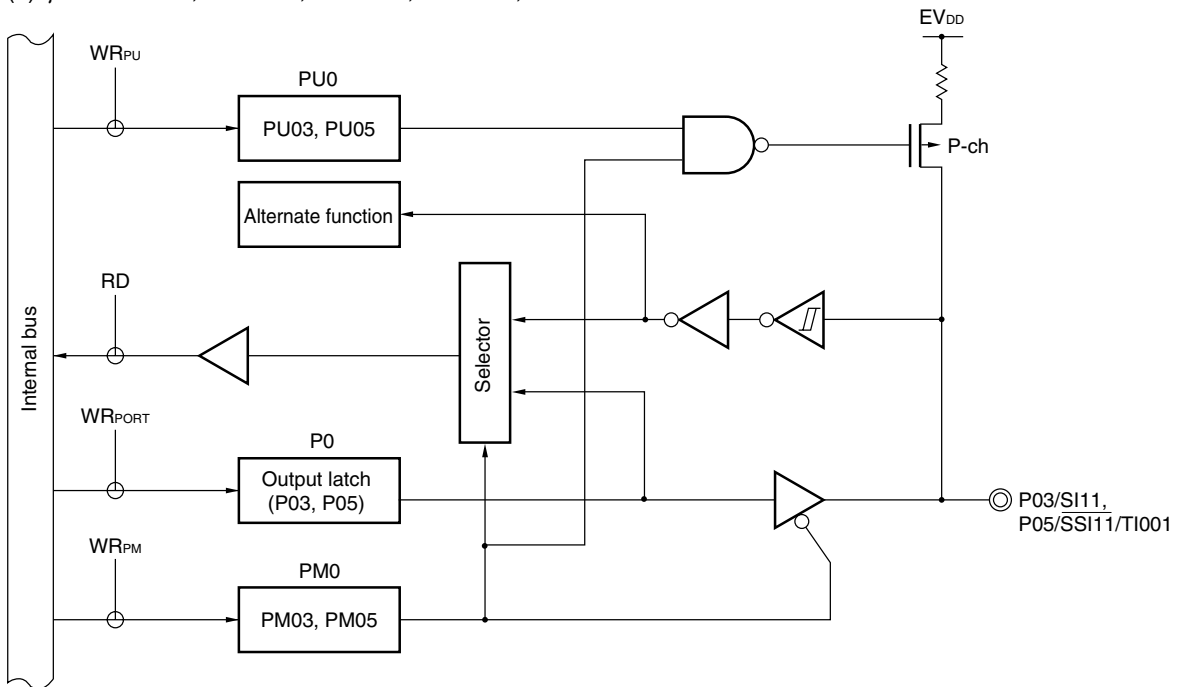

- P0: Port register 0
- PU0: Pull-up resistor option register 0
- PM0: Port mode register 0
- RD: Read signal
- WR_{xx}: Write signal

Figure 5-6. Block Diagram of P04

(a) μ PD78F0531, 78F0532, 78F0533

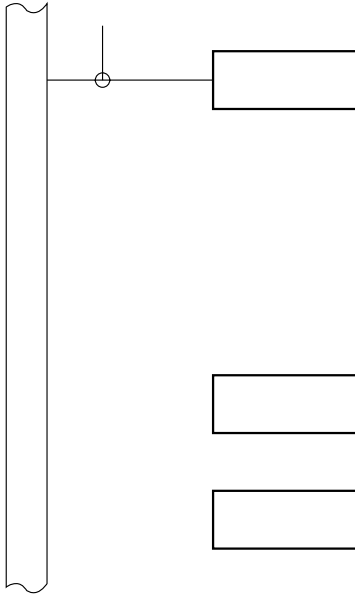

★

Figure 5-7. Block Diagram of P06

(a) μ PD78F0531, 78F0532, 78F0533

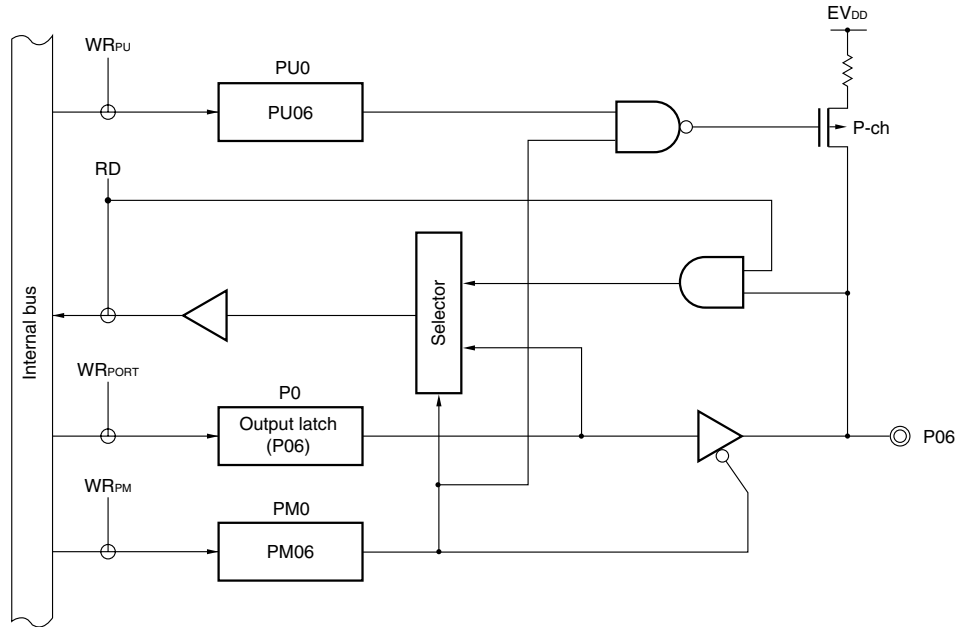

(b) μ PD78F0534, 78F0535, 78F0536, 78F0537, 78F0537D

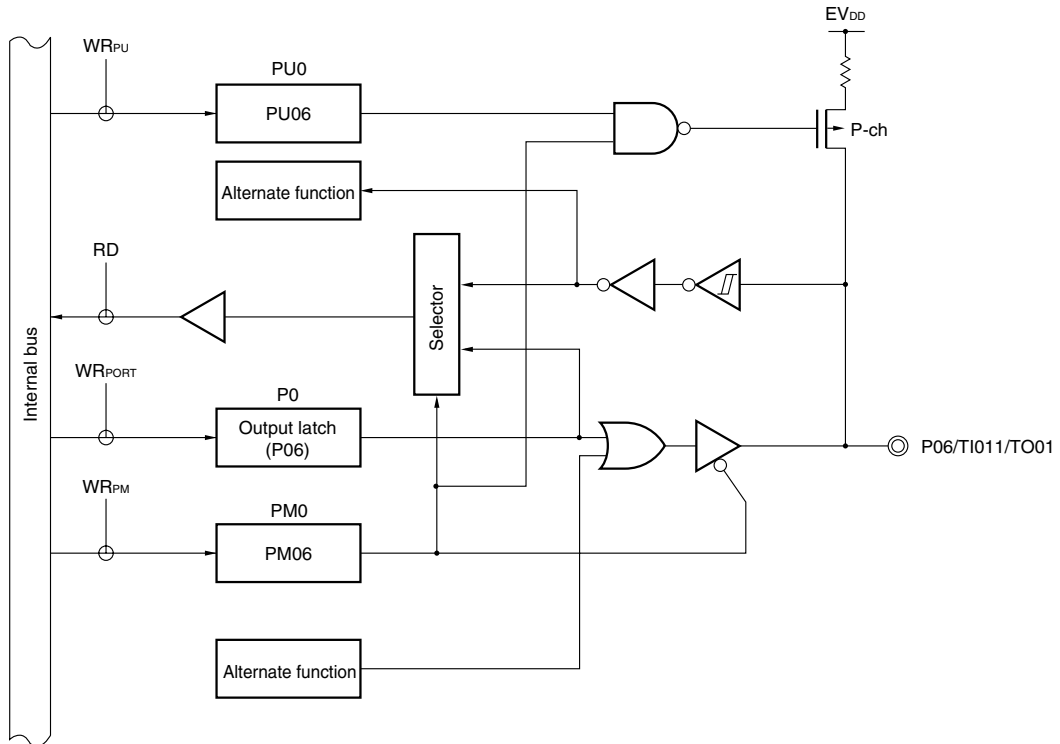

- P0: Port register 0
- PU0: Pull-up resistor option register 0
- PM0: Port mode register 0
- RD: Read signal
- WR \times : Write signal

5.2.2 Port 1

Port 1 is an 8-bit I/O port with an output latch. Port 1 can be set to the input mode or output mode in 1-bit units using port mode register 1 (PM1). When the P10 to P17 pins are used as an input port, use of an on-chip pull-up resistor can be specified in 1-bit units by pull-up resistor option register 1 (PU1).

This port can also be used for external interrupt request input, serial interface data I/O, clock I/O, and timer I/O.

Reset signal generation sets port 1 to input mode.

Figures 5-8 to 5-12 show block diagrams of port 1.

- ★ **Caution** To use P10/ $\overline{\text{SCK10}}$ /TxD0 and P12/SO10 as general-purpose ports, set serial operation mode register 10 (CSIM10) and serial clock selection register 10 (CSIC10) to the default status (00H).

Figure 5-8. Block Diagram of P10

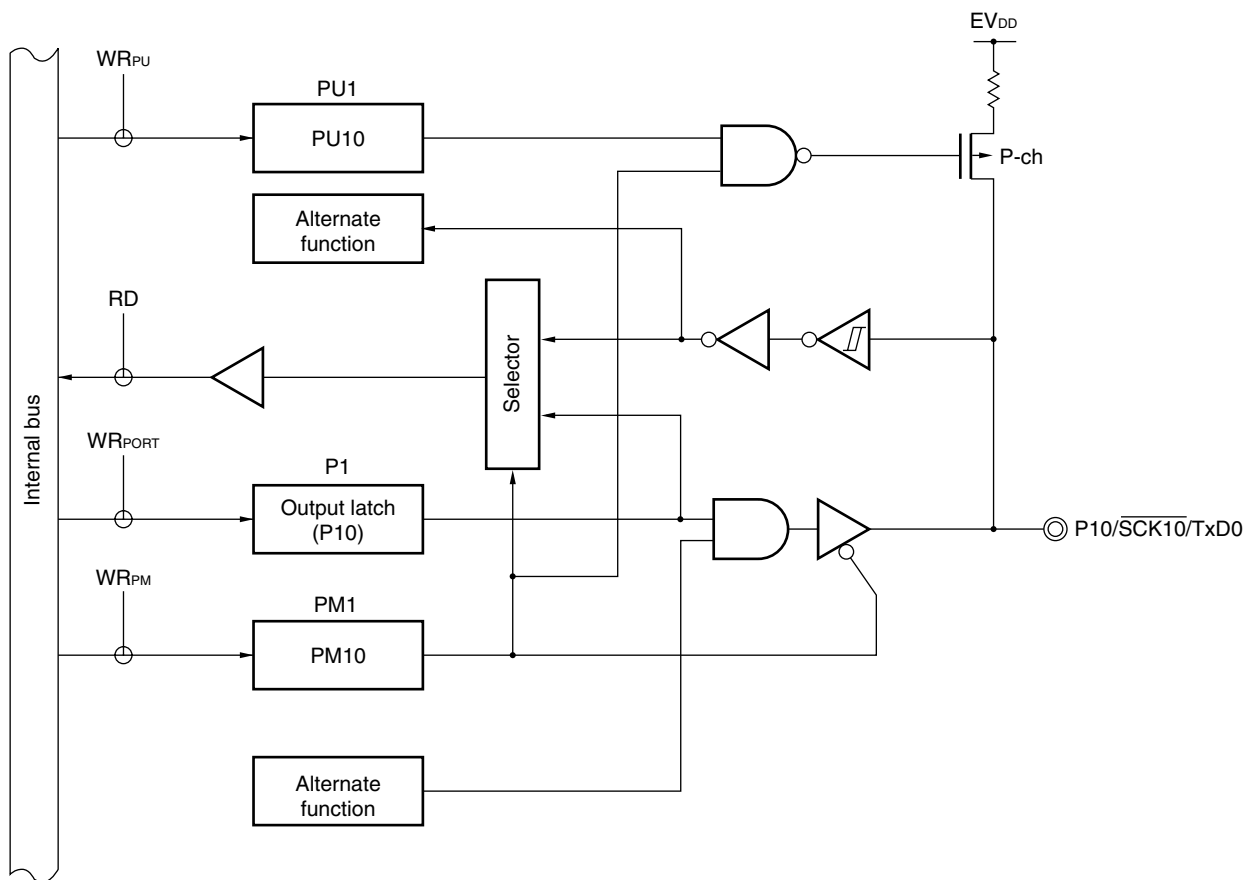

- P1: Port register 1
- PU1: Pull-up resistor option register 1
- PM1: Port mode register 1
- RD: Read signal
- WR_{xx}: Write signal

Figure 5-9. Block Diagram of P11 and P14

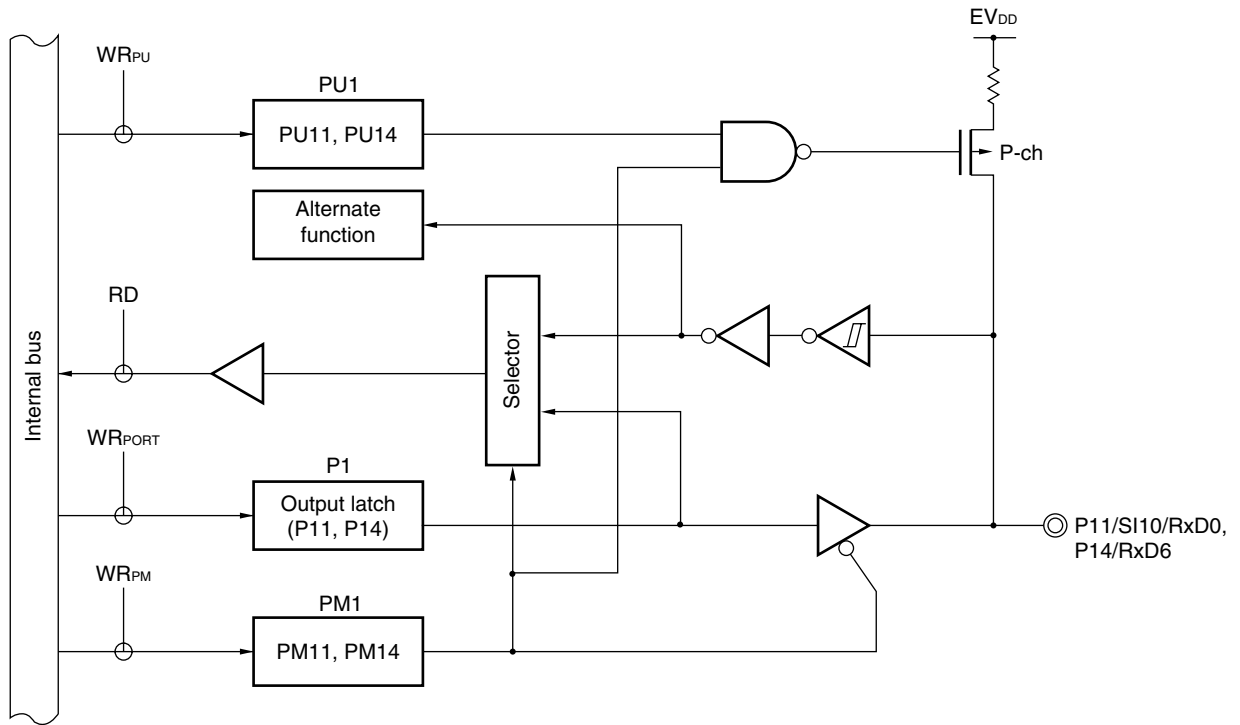

- P1: Port register 1
- PU1: Pull-up resistor option register 1
- PM1: Port mode register 1
- RD: Read signal
- WR_{xx}: Write signal

Figure 5-10. Block Diagram of P12 and P15

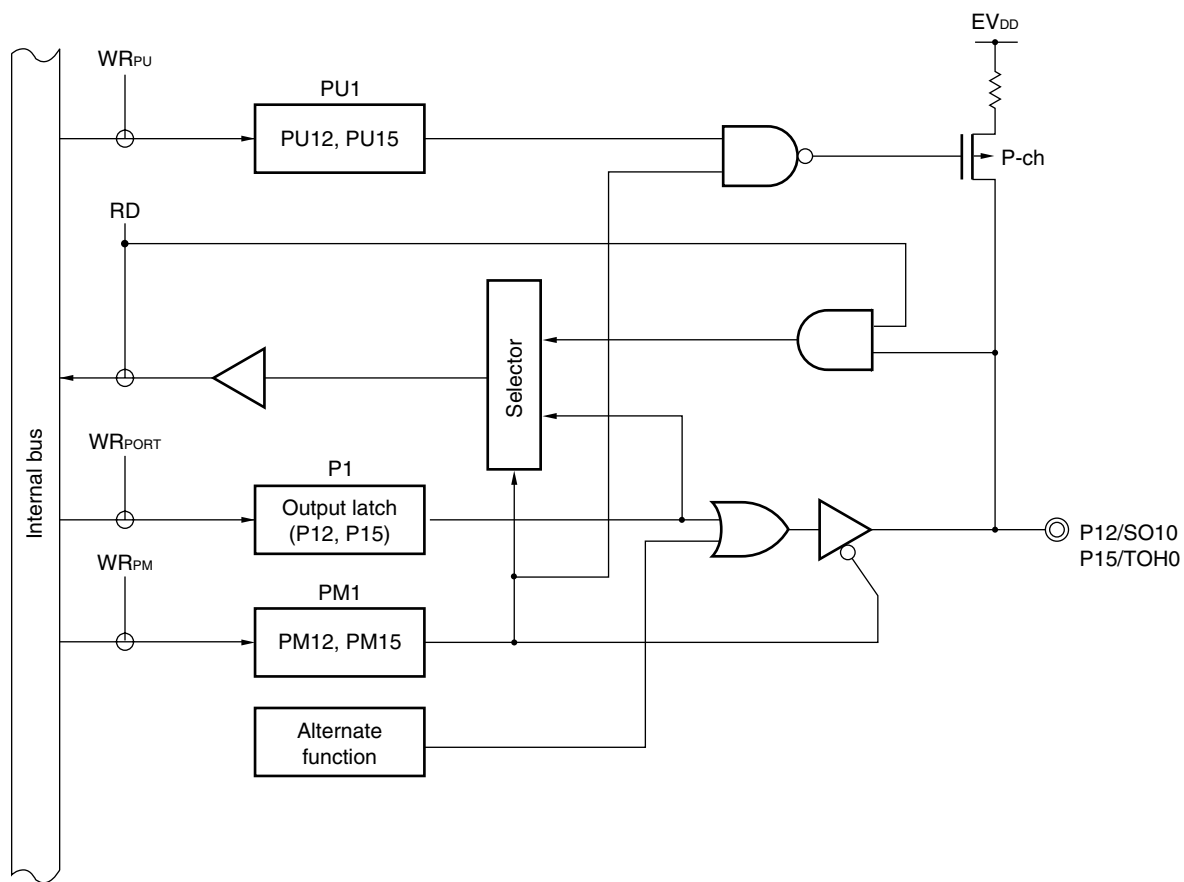

- P1: Port register 1
- PU1: Pull-up resistor option register 1
- PM1: Port mode register 1
- RD: Read signal
- WR_{xx}: Write signal

Figure 5-11. Block Diagram of P13

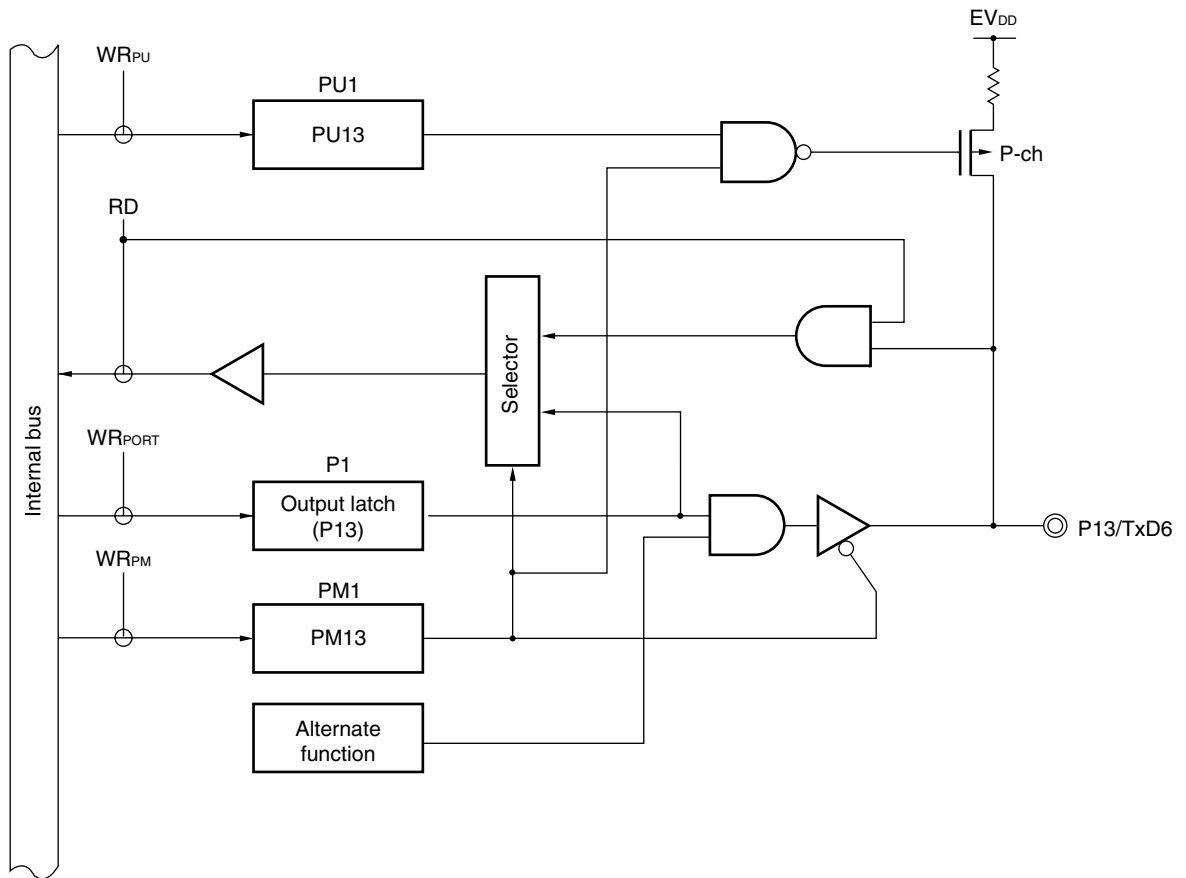

- P1: Port register 1
- PU1: Pull-up resistor option register 1
- PM1: Port mode register 1
- RD: Read signal
- WR_{xx}: Write signal

Figure 5-12. Block Diagram of P16 and P17

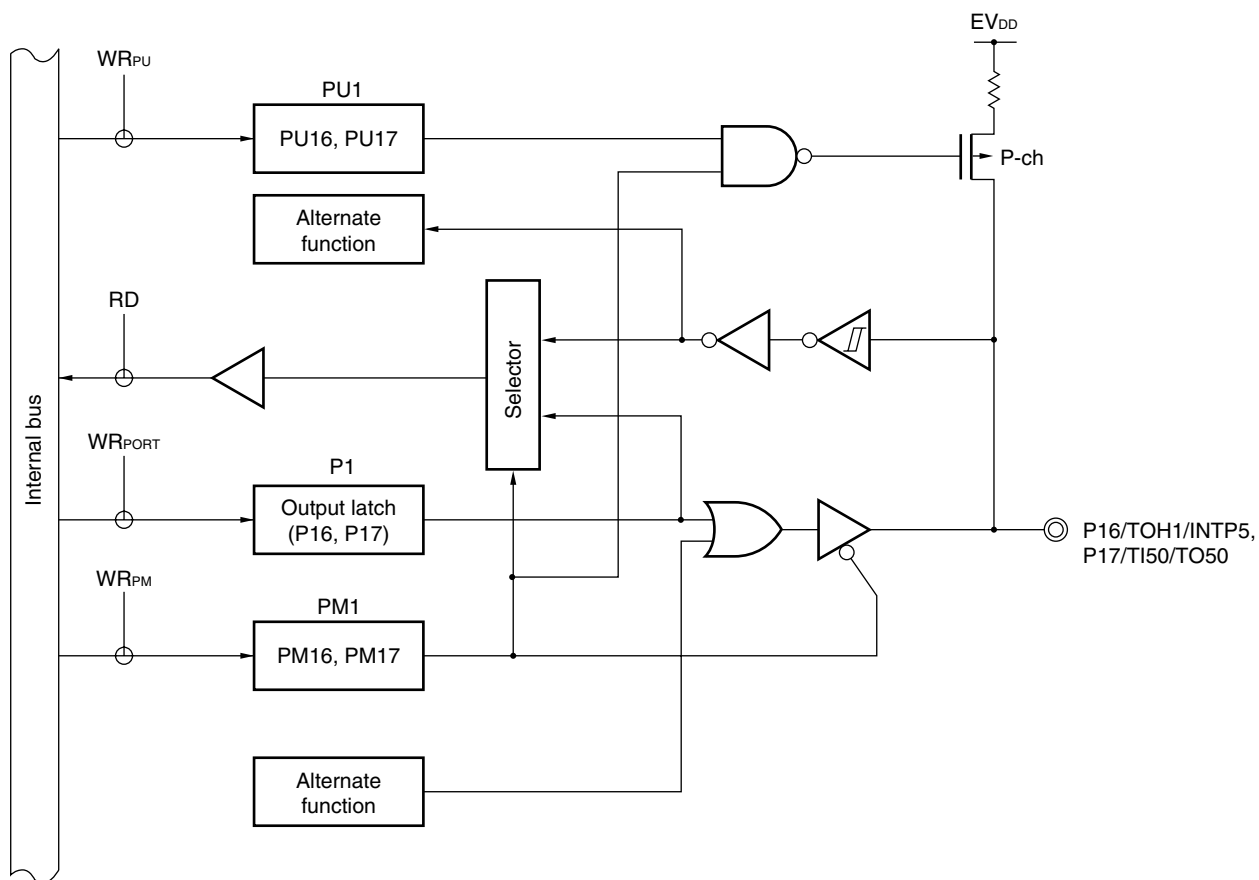

- P1: Port register 1
- PU1: Pull-up resistor option register 1
- PM1: Port mode register 1
- RD: Read signal
- $WR_{\times\times}$: Write signal

5.2.3 Port 2

Port 2 is an 8-bit I/O port with an output latch. Port 2 can be set to the input mode or output mode in 1-bit units using port mode register 2 (PM2).

This port can also be used for A/D converter analog input.

★ To use P20/ANI0 to P27/ANI7 as digital input pins, set them in the digital I/O mode by using the A/D port configuration register (ADPC) and in the input mode by using PM2. Use these pins starting from the lower bit.

To use P20/ANI0 to P27/ANI7 as digital output pins, set them in the digital I/O mode by using ADPC and in the output mode by using PM2.

★ **Table 5-4. Setting Functions of P20/ANI0 to P27/ANI7 Pins**

ADPC	PM2	ADS	P20/ANI0 to P27/ANI7 Pin
Digital I/O selection	Input mode	Selects ANI.	Setting prohibited
		Does not select ANI.	Digital input
	Output mode	Selects ANI.	Setting prohibited
		Does not select ANI.	Digital output
Analog input selection	Input mode	Selects ANI.	Analog input (to be converted)
		Does not select ANI.	Analog input (not to be converted)
	Output mode	Selects ANI.	Setting prohibited
		Does not select ANI.	

All P20/ANI0 to P27/ANI7 are set in the analog input mode when the reset signal is generated.

Figure 5-13 shows a block diagram of port 2.

Figure 5-13. Block Diagram of P20 to P27

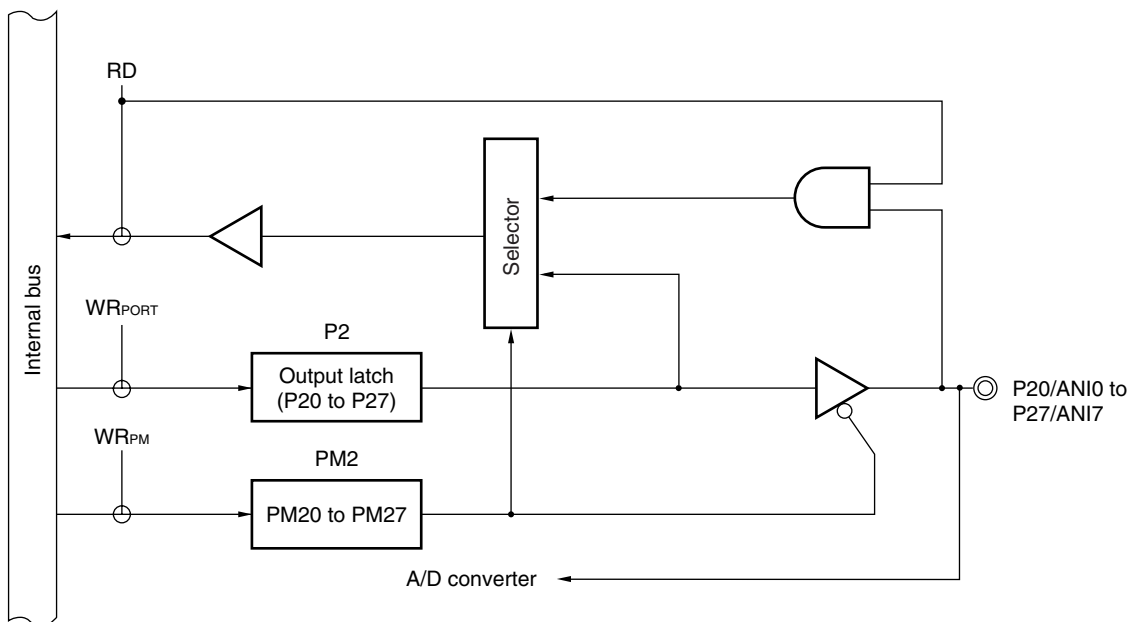

- P2: Port register 2
- PM2: Port mode register 2
- RD: Read signal
- WR_{xx}: Write signal

5.2.4 Port 3

Port 3 is a 4-bit I/O port with an output latch. Port 3 can be set to the input mode or output mode in 1-bit units using port mode register 3 (PM3). When the P30 to P33 pins are used as an input port, use of an on-chip pull-up resistor can be specified in 1-bit units by pull-up resistor option register 3 (PU3).

This port can also be used for external interrupt request input and timer I/O.

Reset signal generation sets port 3 to input mode.

Figures 5-14 and 5-15 show block diagrams of port 3.

Caution In the μ PD78F0537D, be sure to pull the P31 pin down before a reset release to prevent malfunction.

Remark The P31 and P32 pins of the μ PD78F0537D can be used as on-chip debug mode setting pins (OCD1A, OCD1B) when the on-chip debug function is used. For details, see **CHAPTER 27 ON-CHIP DEBUG FUNCTION (μ PD78F0537D ONLY)**.

Figure 5-14. Block Diagram of P30 to P32

Figure 5-15. Block Diagram of P33

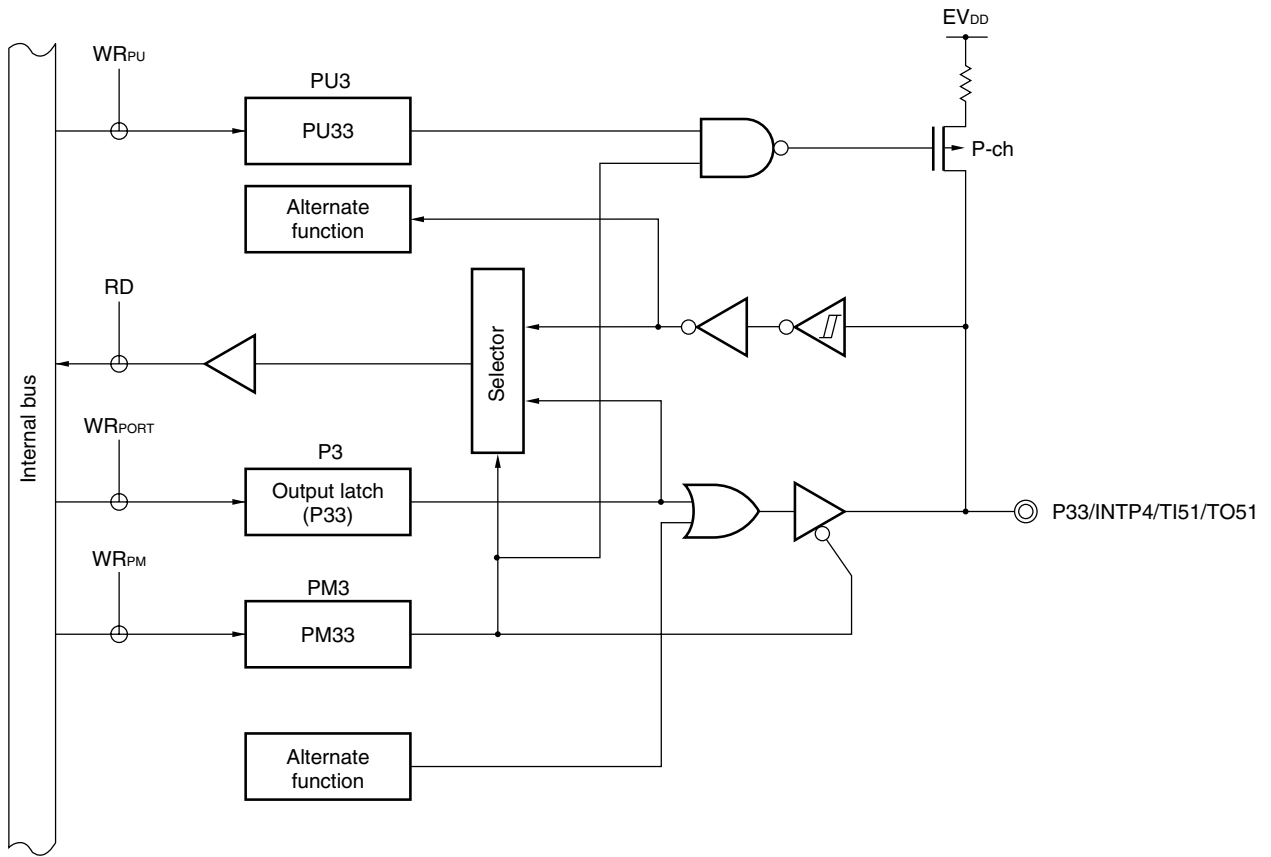

- P3: Port register 3
- PU3: Pull-up resistor option register 3
- PM3: Port mode register 3
- RD: Read signal
- WR_{xx}: Write signal

5.2.5 Port 4

Port 4 is a 4-bit I/O port with an output latch. Port 4 can be set to the input mode or output mode in 1-bit units using port mode register 4 (PM4). When the P40 to P43 pins are used as an input port, use of an on-chip pull-up resistor can be specified in 1-bit units by pull-up resistor option register 4 (PU4).

Reset signal generation sets port 4 to input mode.

Figure 5-16 shows a block diagram of port 4.

Figure 5-16. Block Diagram of P40 to P43

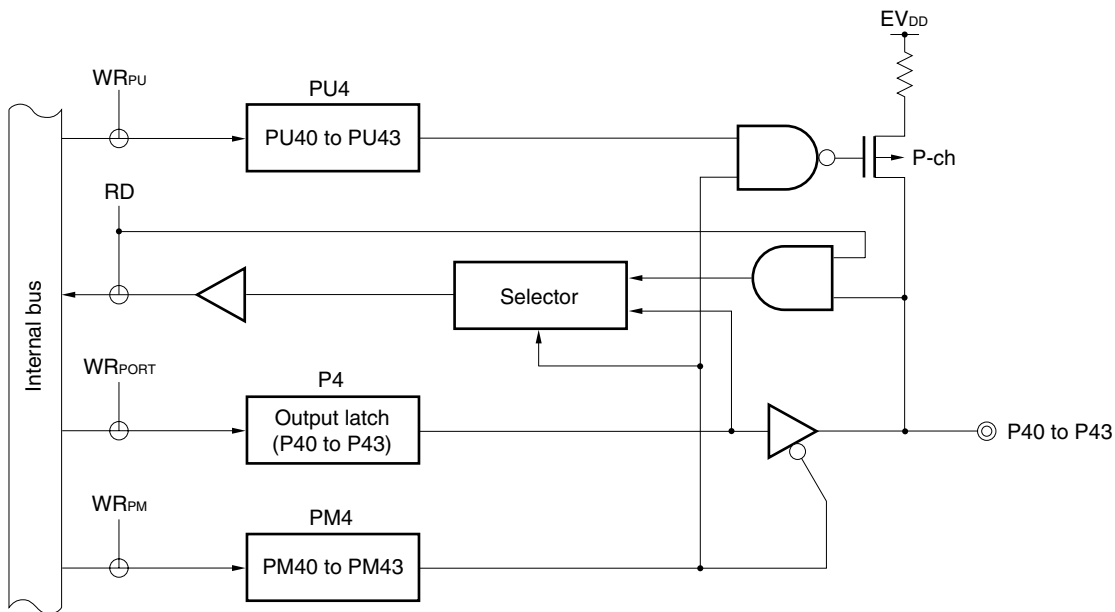

- P4: Port register 4
- PU4: Pull-up resistor option register 4
- PM4: Port mode register 4
- RD: Read signal
- WR_{xx} : Write signal

5.2.6 Port 5

Port 5 is a 4-bit I/O port with an output latch. Port 5 can be set to the input mode or output mode in 1-bit units using port mode register 5 (PM5). When the P50 to P53 pins are used as an input port, use of an on-chip pull-up resistor can be specified in 1-bit units by pull-up resistor option register 5 (PU5).

Reset signal generation sets port 5 to input mode.

5.2.7 Port 6

Port 6 is a 4-bit I/O port with an output latch. Port 6 can be set to the input mode or output mode in 1-bit units using port mode register 6 (PM6).

The output of the P60 to P63 pins is N-ch open-drain output (6 V tolerance).

This port can also be used for serial interface data I/O, clock I/O, and external clock input.

Reset signal generation sets port 6 to input mode.

Figures 5-18 to 5-20 show block diagrams of port 6.

Remark When using P62/EXSCL0 as an external clock input pin of the serial interface, input a clock of 6.4 MHz to it.

Figure 5-18. Block Diagram of P60 and P61

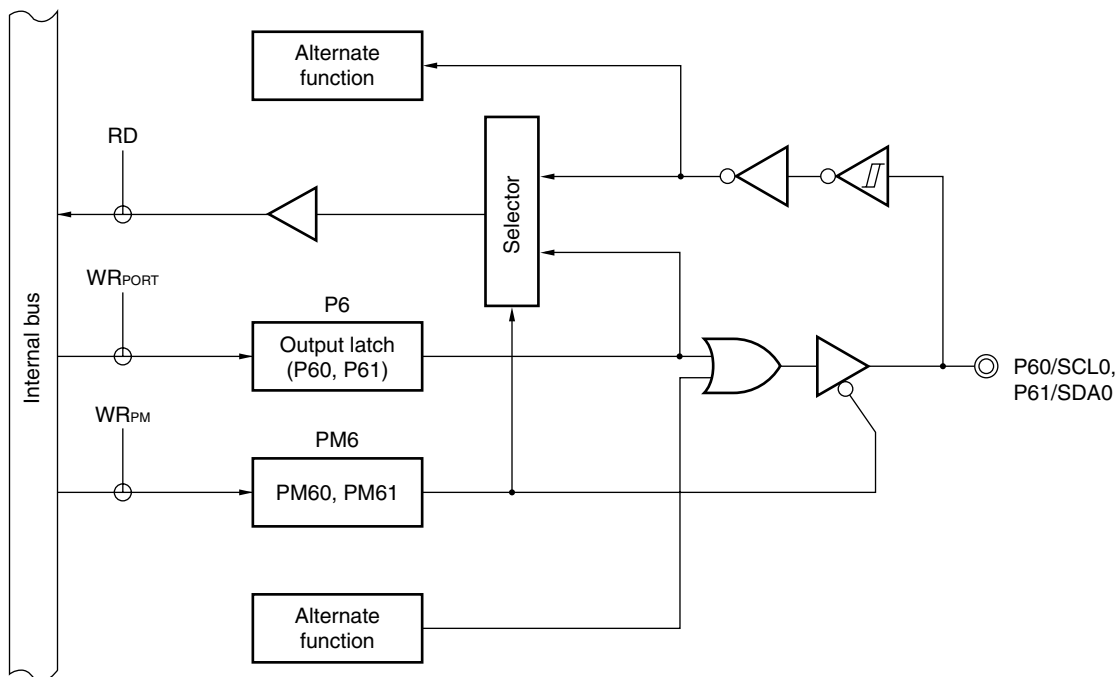

- P6: Port register 6
- PM6: Port mode register 6
- RD: Read signal
- WR_{xx}: Write signal

Figure 5-19. Block Diagram of P62

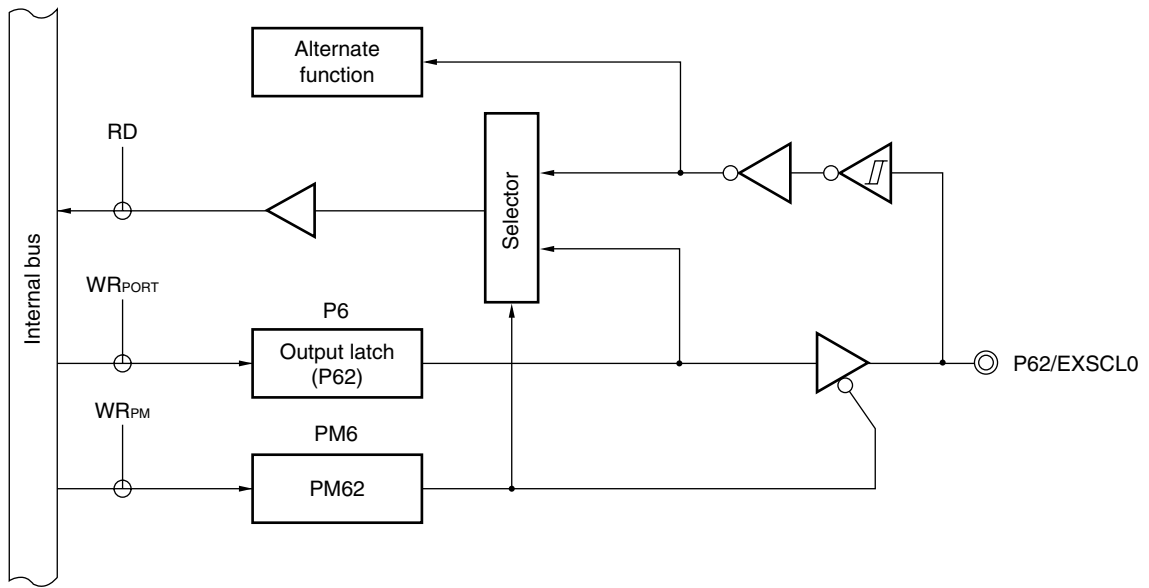

P6: Port register 6
 PM6: Port mode register 6
 RD: Read signal
 WR_{xx}: Write signal

Figure 5-20. Block Diagram of P63

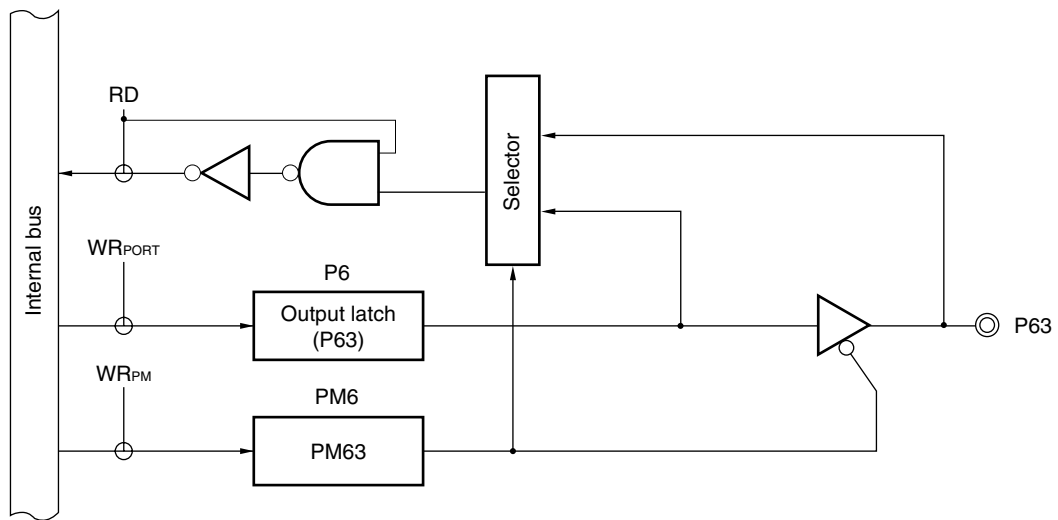

P6: Port register 6
 PM6: Port mode register 6
 RD: Read signal
 WR_{xx}: Write signal

5.2.9 Port 12

Port 12 is a 5-bit I/O port with an output latch. Port 12 can be set to the input mode or output mode in 1-bit units using port mode register 12 (PM12). When used as an input port only for P120, use of an on-chip pull-up resistor can be specified by pull-up resistor option register 12 (PU12).

This port can also be used as pins for external interrupt request input, potential input for external low-voltage detection, connecting resonator for main system clock, connecting resonator for subsystem clock, external clock input for main system clock, and external clock input for subsystem clock.

Reset signal generation sets port 12 to input mode.

Figures 5-22 and 5-23 show block diagrams of port 12.

Caution When using the P121 to P124 pins to connect a resonator for the main system clock (X1, X2) or subsystem clock (XT1, XT2), or to input an external clock for the main system clock (EXCLK) or subsystem clock (EXCLKS), the X1 oscillation mode, XT1 oscillation mode, or external clock input mode must be set by using the clock operation mode select register (OSCCTL) (for details, see 6.3 (1) Clock operation mode select register (OSCCTL) and (3) Setting of operation mode for subsystem clock pin). The reset value of OSCCTL is 00H (all of the P121 to P124 pins are I/O port pins). At this time, setting of the PM121 to PM124 and P121 to P124 pins is not necessary.

Remark The X1 and X2 pins of the μ PD78F0537D can be used as on-chip debug mode setting pins (OCD0A, OCD0B) when the on-chip debug function is used. For details, see CHAPTER 27 ON-CHIP DEBUG FUNCTION (μ PD78F0537D ONLY).

Figure 5-22. Block Diagram of P120

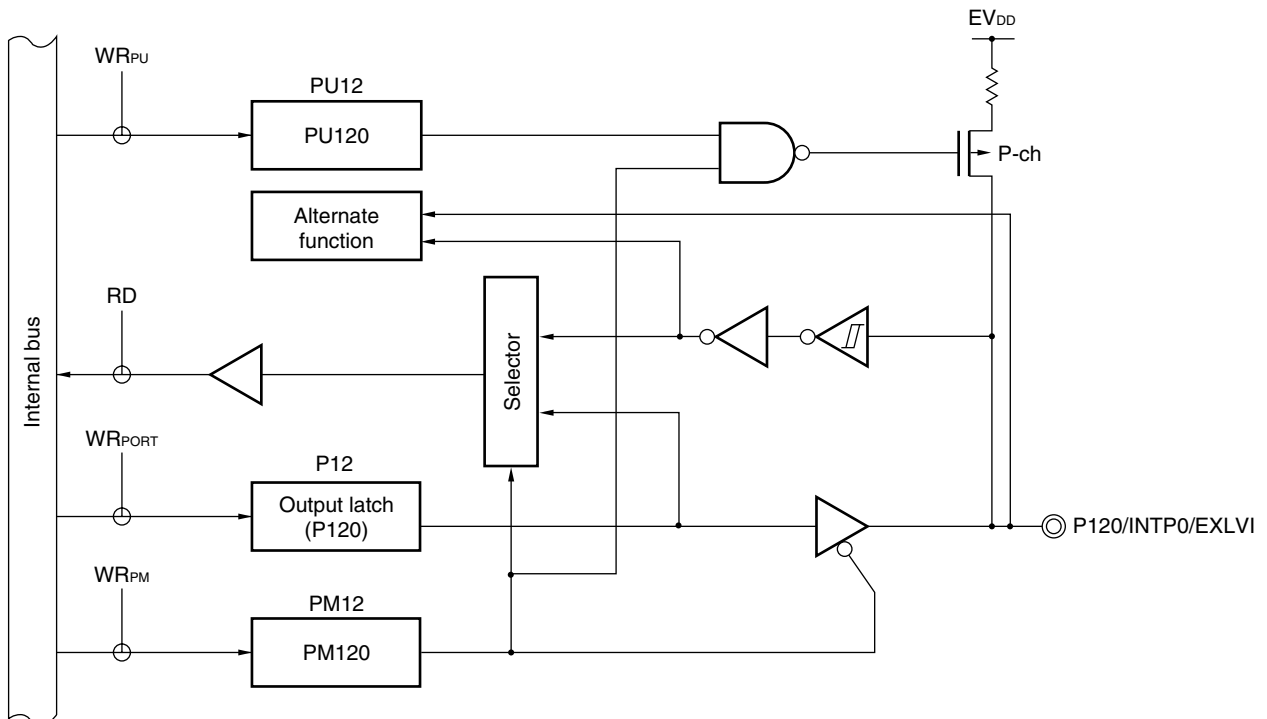

- P12: Port register 12
- PU12: Pull-up resistor option register 12
- PM12: Port mode register 12
- RD: Read signal
- WR_{xx}: Write signal

Figure 5-23. Block Diagram of P121 to P124

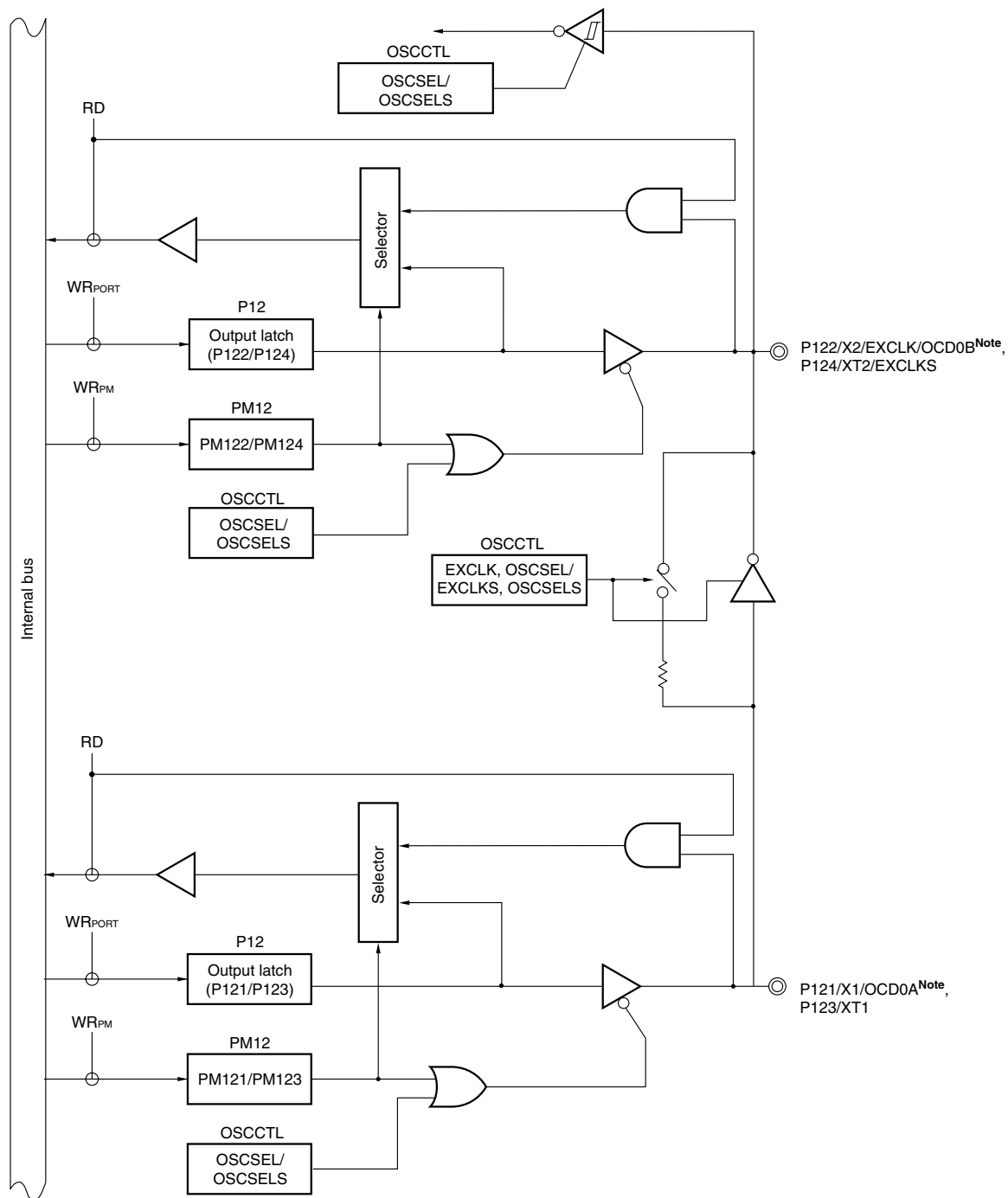

P12: Port register 12
 PU12: Pull-up resistor option register 12
 PM12: Port mode register 12
 OSCCTL: Clock operation mode select register
 RD: Read signal
 WR \times : Write signal

Note μ PD78F0537D only

5.2.10 Port 13

Port 13 is a 1-bit output-only port.

Figure 5-24 shows a block diagram of port 13.

Figure 5-24. Block Diagram of P130

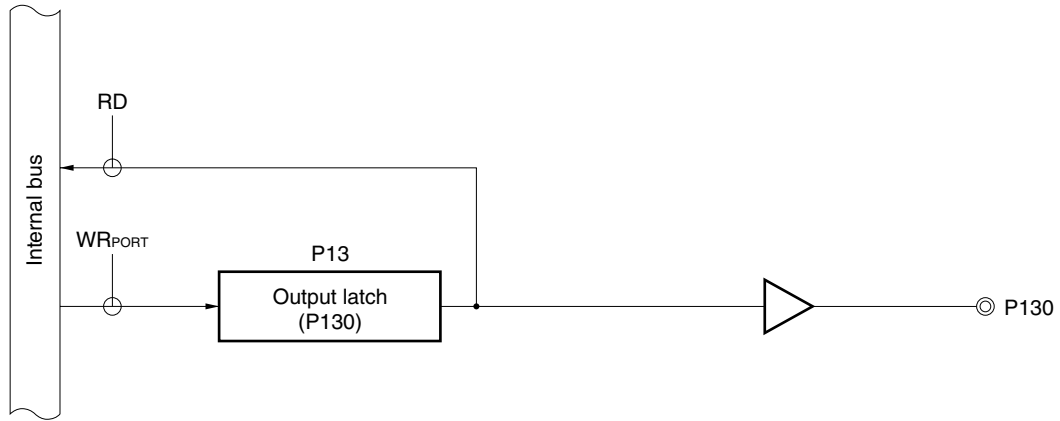

- P13: Port register 13
- RD: Read signal
- WR_{xx}: Write signal

Remark When reset is effected, P130 outputs a low level. If P130 is set to output a high level before reset is effected, the output signal of P130 can be dummy-output as the CPU reset signal.

★

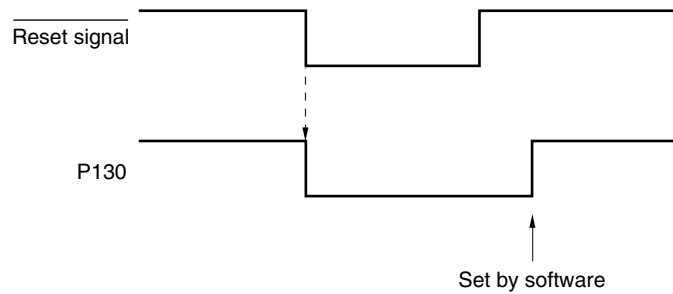

5.2.11 Port 14

Port 14 is a 6-bit I/O port with an output latch. Port 14 can be set to the input mode or output mode in 1-bit units using port mode register 14 (PM14). When the P140 and P141 pins are used as an input port, use of an on-chip pull-up resistor can be specified in 1-bit units by pull-up resistor option register 14 (PU14).

This port can also be used for external interrupt request input, buzzer output, clock output, serial interface data I/O, clock I/O, busy input, and strobe output.

Reset signal generation sets port 14 to input mode.

Figure 5-25 shows a block diagram of port 14.

Figure 5-25. Block Diagram of P140 and P141

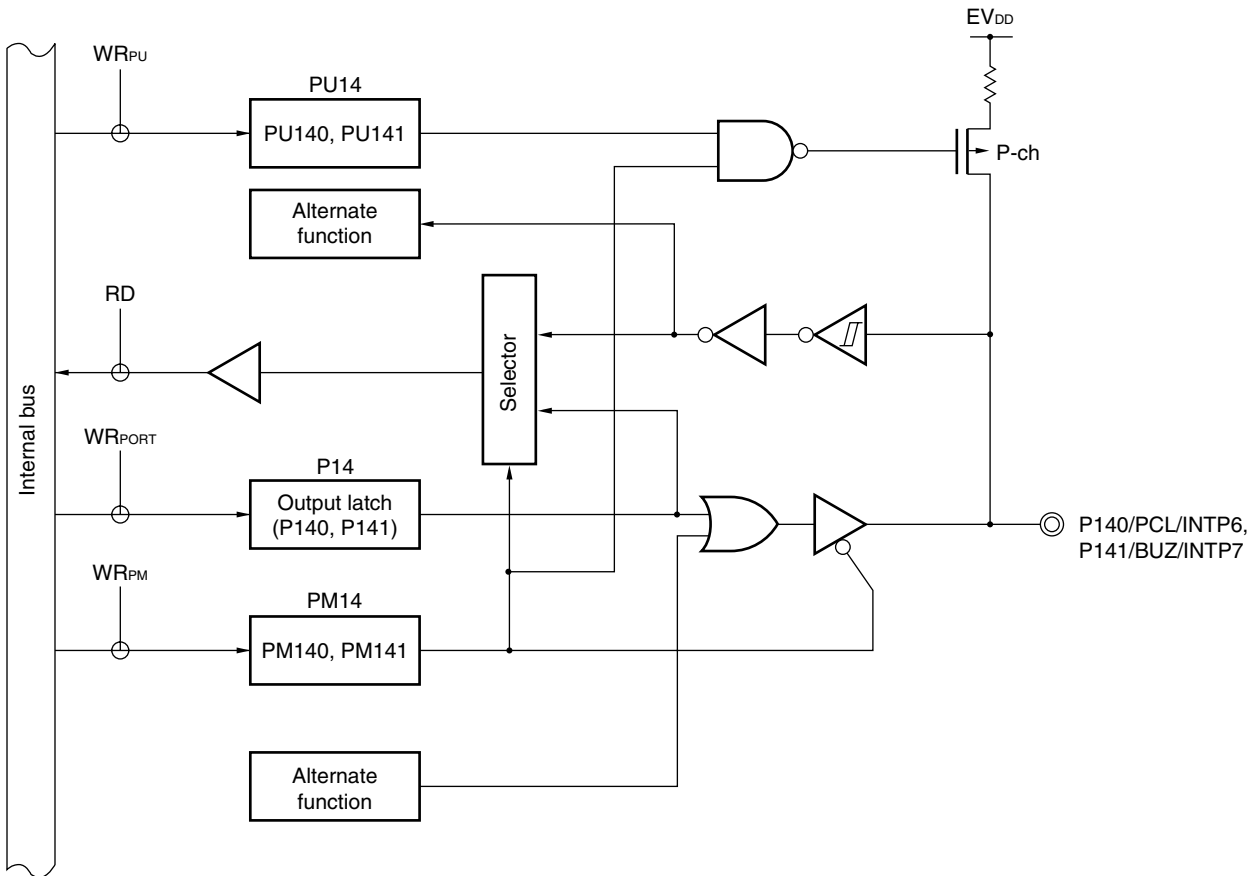

- P14: Port register 14
- PU14: Pull-up resistor option register 14
- PM14: Port mode register 14
- RD: Read signal
- WR_{xx}: Write signal

5.3 Registers Controlling Port Function

Port functions are controlled by the following four types of registers.

- Port mode registers (PM0 to PM7, PM12, PM14)
- Port registers (P0 to P7, P12 to P14)
- Pull-up resistor option registers (PU0, PU1, PU3 to PU5, PU7, PU12, PU14)
- A/D port configuration register (ADPC)

(1) Port mode registers (PM0 to PM7, PM12, and PM14)

These registers specify input or output mode for the port in 1-bit units.

These registers can be set by a 1-bit or 8-bit memory manipulation instruction.

Reset signal generation sets these registers to FFH.

When port pins are used as alternate-function pins, set the port mode register by referencing **5.5 Settings of Port Mode Register and Output Latch When Using Alternate Function**.

Figure 5-26. Format of Port Mode Register

Symbol	7	6	5	4	3	2	1	0	Address	After reset	R/W
PM0	1	PM06	PM05	PM04	PM03	PM02	PM01	PM00	FF20H	FFH	R/W
PM1	PM17	PM16	PM15	PM14	PM13	PM12	PM11	PM10	FF21H	FFH	R/W
PM2	PM27	PM26	PM25	PM24	PM23	PM22	PM21	PM20	FF22H	FFH	R/W
PM3	1	1	1	1	PM33	PM32	PM31	PM30	FF23H	FFH	R/W
PM4	1	1	1	1	PM43	PM42	PM41	PM40	FF24H	FFH	R/W
PM5	1	1	1	1	PM53	PM52	PM51	PM50	FF25H	FFH	R/W
PM6	1	1	1	1	PM63	PM62	PM61	PM60	FF26H	FFH	R/W
PM7	PM77	PM76	PM75	PM74	PM73	PM72	PM71	PM70	FF27H	FFH	R/W
PM12	1	1	1	PM124	PM123	PM122	PM121	PM120	FF2CH	FFH	R/W
PM14	1	1	1	1	1	1	PM141	PM140	FF2EH	FFH	R/W

PMmn	Pmn pin I/O mode selection (m = 0 to 7, 12, 14; n = 0 to 7)
0	Output mode (output buffer on)
1	Input mode (output buffer off)

(2) Port registers (P0 to P7, P12 to P14)

These registers write the data that is output from the chip when data is output from a port.

If the data is read in the input mode, the pin level is read. If it is read in the output mode, the value of the output latch is read.

These registers can be set by a 1-bit or 8-bit memory manipulation instruction.

Reset signal generation sets these registers to 00H.

Figure 5-27. Format of Port Register

Symbol	7	6	5	4	3	2	1	0	Address	After reset	R/W
P0	0	P06	P05	P04	P03	P02	P01	P00	FF00H	00H (output latch)	R/W
P1	P17	P16	P15	P14	P13	P12	P11	P10	FF01H	00H (output latch)	R/W
P2	P27	P26	P25	P24	P23	P22	P21	P20	FF02H	00H (output latch)	R/W
P3	0	0	0	0	P33	P32	P31	P30	FF03H	00H (output latch)	R/W
P4	0	0	0	0	P43	P42	P41	P40	FF04H	00H (output latch)	R/W
P5	0	0	0	0	P53	P52	P51	P50	FF05H	00H (output latch)	R/W
P6	0	0	0	0	P63	P62	P61	P60	FF06H	00H (output latch)	R/W
P7	P77	P76	P75	P74	P73	P72	P71	P70	FF07H	00H (output latch)	R/W
P12	0	0	0	P124	P123	P122	P121	P120	FF0CH	00H (output latch)	R/W
P13	0	0	0	0	0	0	0	P130	FF0DH	00H (output latch)	R/W
P14	0	0	0	0	0	0	P141	P140	FF0EH	00H (output latch)	R/W

Pmn	m = 0 to 7, 12 to 14; n = 0 to 7	
	Output data control (in output mode)	Input data read (in input mode)
0	Output 0	Input low level
1	Output 1	Input high level

(3) Pull-up resistor option registers (PU0, PU1, PU3 to PU5, PU7, PU12, and PU14)

These registers specify whether the on-chip pull-up resistors of P00 to P06, P10 to P17, P30 to P33, P40 to P43, P50 to P53, P70 to P77, P120, or P140 and P141 are to be used or not. On-chip pull-up resistors can be used in 1-bit units only for the bits set to input mode of the pins to which the use of an on-chip pull-up resistor has been specified in PU0, PU1, PU3 to PU5, PU7, PU12, and PU14. On-chip pull-up resistors cannot be connected to bits set to output mode and bits used as alternate-function output pins, regardless of the settings of PU0, PU1, PU3 to PU5, PU7, PU12, and PU14.

These registers can be set by a 1-bit or 8-bit memory manipulation instruction.

Reset signal generation sets these registers to 00H.

Figure 5-28. Format of Pull-up Resistor Option Register

Symbol	7	6	5	4	3	2	1	0	Address	After reset	R/W
PU0	0	PU06	PU05	PU04	PU03	PU02	PU01	PU00	FF30H	00H	R/W
PU1	PU17	PU16	PU15	PU14	PU13	PU12	PU11	PU10	FF31H	00H	R/W
PU3	0	0	0	0	PU33	PU32	PU31	PU30	FF33H	00H	R/W
PU4					PU43	PU42	PU41	PU40	FF34H	00H	R/W

★ (4) **A/D port configuration register (ADPC)**

This register switches the P20/ANI0 to P27/ANI7 pins to digital I/O of port or analog input of A/D converter. ADPC can be set by a 1-bit or 8-bit memory manipulation instruction. Reset signal generation sets this register to 00H.

Figure 5-29. Format of A/D Port Configuration Register (ADPC)

Address: FF2FH After reset: 00H R/W

Symbol	7	6	5	4	3	2	1	0
ADPC	0	0	0	0	ADPC3	ADPC2	ADPC1	ADPC0

ADPC3	ADPC2	ADPC1	ADPC0	Digital I/O (D)/analog input (A) switching							
				P27/ ANI7	P26/ ANI6	P25/ ANI5	P24/ ANI4	P23/ ANI3	P22/ ANI2	P21/ ANI1	P20/ ANI0
0	0	0	0	A	A	A	A	A	A	A	A
0	0	0	1	A	A	A	A	A	A	A	D
0	0	1	0	A	A	A	A	A	A	D	D
0	0	1	1	A	A	A	A	A	D	D	D
0	1	0	0	A	A	A	A	D	D	D	D
0	1	0	1	A	A	A	D	D	D	D	D
0	1	1	0	A	A	D	D	D	D	D	D
0	1	1	1	A	D	D	D	D	D	D	D
1	0	0	0	D	D	D	D	D	D	D	D
Other than above				Setting prohibited							

- Cautions**
1. Set the channel used for A/D conversion to the input mode by using port mode register 2 (PM2).
 2. Do not set a pin to be used as a digital I/O pin with ADPC by using the analog input channel specification register (ADS).
 3. If data is written to ADPC, a wait cycle is generated. Do not write data to ADPC when the CPU is operating on the subsystem clock and the peripheral hardware clock is stopped. For details, see CHAPTER 31 CAUTIONS FOR WAIT.

5.4 Port Function Operations

Port operations differ depending on whether the input or output mode is set, as shown below.

Caution In the case of 1-bit memory manipulation instruction, although a single bit is manipulated, the port is accessed as an 8-bit unit. Therefore, on a port with a mixture of input and output pins, the output latch contents for pins specified as input are undefined, even for bits other than the manipulated bit.

5.4.1 Writing to I/O port

(1) Output mode

A value is written to the output latch by a transfer instruction, and the output latch contents are output from the pin. Once data is written to the output latch, it is retained until data is written to the output latch again. The data of the output latch is cleared when a reset signal is generated.

(2) Input mode

A value is written to the output latch by a transfer instruction, but since the output buffer is off, the pin status does not change. Once data is written to the output latch, it is retained until data is written to the output latch again. The data of the output latch is cleared when a reset signal is generated.

5.4.2 Reading from I/O port

(1) Output mode

The output latch contents are read by a transfer instruction. The output latch contents do not change.

(2) Input mode

The pin status is read by a transfer instruction. The output latch contents do not change.

5.4.3 Operations on I/O port

(1) Output mode

An operation is performed on the output latch contents, and the result is written to the output latch. The output latch contents are output from the pins. Once data is written to the output latch, it is retained until data is written to the output latch again. The data of the output latch is cleared when a reset signal is generated.

(2) Input mode

The pin level is read and an operation is performed on its contents. The result of the operation is written to the output latch, but since the output buffer is off, the pin status does not change. The data of the output latch is cleared when a reset signal is generated.

5.5 Settings of Port Mode Register and Output Latch When Using Alternate Function

To use the alternate function of a port pin, set the port mode register and output latch as shown in Table 5-5.

Table 5-5. Settings of Port Mode Register and Output Latch When Using Alternate Function (1/2)

Pin Name	Alternate Function		PM _{xx}	P _{xx}
	Function Name	I/O		
P00	TI000	Input	1	×
P01	TI010	Input	1	×
	TO00	Output	0	0
P02	SO11 ^{Note}	Output	0	0
P03	SI11 ^{Note}	Input	1	×
P04	SCK11 ^{Note}	Input	1	×
		Output	0	1
P05	SSI11 ^{Note}	Input	1	×
	TI001 ^{Note}	Input	1	×
P06	TI011 ^{Note}	Input	1	×
	TO01 ^{Note}	Output	0	0
P10	SCK10	Input	1	×
		Output	0	1
	TxD0	Output	0	1
P11	SI10	Input	1	×
	RxD0	Input	1	×
P12	SO10	Output	0	0
P13	TxD6	Output	0	1
P14	RxD6	Input	1	×
P15	TOH0	Output	0	0
P16	TOH1	Output	0	0
	INTP5	Input	1	×
P17	TI50	Input	1	×
	TO50	Output	0	0

Note Available only in the μ PD78F0534, 78F0535, 78F0536, 78F0537, and 78F0537D.

Remark ×: Don't care
 PM_{xx}: Port mode register
 P_{xx}: Port output latch

Table 5-5. Settings of Port Mode Register and Output Latch When Using Alternate Function (2/2)

Pin Name	Alternate Function		PM _{xx}	P _{xx}
	Function Name	I/O		
P20 to P27 ^{Note 1}	ANI0 to ANI7 ^{Note 1}	Input	1	×
P30 to P32	INTP1 to INTP3	Input	1	×
P33	INTP4	Input	1	×
	TI51	Input	1	×
	TO51	Output	0	0
P60	SCL0	I/O	0	0
P61	SDA0	I/O	0	0
P62	EXSCL0	Input	1	×
P70 to P77	KR0 to KR7	Input	1	×
P120	INTP0	Input	1	×
	EXLVI	Input	1	×
★ P121	X1 ^{Note 2}	–	×	×
★ P122	X2 ^{Note 2}	–	×	×
	EXCLK ^{Note 2}	Input	×	×
★ P123	XT1 ^{Note 2}	–	×	×
★ P124	XT2 ^{Note 2}	–	×	×
	EXCLKS ^{Note 2}	Input	×	×
P140	PCL	Output	0	0
	INTP6	Input	1	×
P141	BUZ	Output	0	0
	INTP7	Input	1	×

Remarks 1. ×: Don't care

PM_{xx}: Port mode register

P_{xx}: Port output latch

- ★ 2. The X1, X2, P31, and P32 pins of the μ PD78F0537D can be used as on-chip debug mode setting pins (OCD0A, OCD0B, OCD1A, OCD1B) when the on-chip debug function is used. For details, see **CHAPTER 27 ON-CHIP DEBUG FUNCTION (μ PD78F0537D ONLY).**

(Notes 1 and 2 are listed on the next page.)

- ★ **Notes 1.** The function of the ANI0/P20 to ANI7/P27 pins can be selected by using the A/D port configuration register (ADPC), the analog input channel specification register (ADS), and PM2.

Table 5-6. Setting Functions of ANI0/P20 to ANI7/P27 Pins

ADPC	PM2	ADS	ANI0/P20 to ANI7/P27 Pins
Analog input selection	Input mode	Selects ANI.	Analog input (to be converted)
		Does not select ANI.	Analog input (not to be converted)
	Output mode	Selects ANI.	Setting prohibited
		Does not select ANI.	
Digital I/O selection	Input mode	Selects ANI.	Setting prohibited
		Does not select ANI.	Digital input
	Output mode	Selects ANI.	Setting prohibited
		Does not select ANI.	Digital output

- ★ **2.** When using the P121 to P124 pins to connect a resonator for the main system clock (X1, X2) or subsystem clock (XT1, XT2), or to input an external clock for the main system clock (EXCLK) or subsystem clock (EXCLKS), the X1 oscillation mode, XT1 oscillation mode, or external clock input mode must be set by using the clock operation mode select register (OSCCTL) (for details, see **6.3 (1) Clock operation mode select register (OSCCTL)** and **(3) Setting of operation mode for subsystem clock pin**). The reset value of OSCCTL is 00H (all of the P121 to P124 are I/O port pins). At this time, setting of PM121 to PM124 and P121 to P124 is not necessary.

CHAPTER 6 CLOCK GENERATOR

6.1 Functions of Clock Generator

The clock generator generates the clock to be supplied to the CPU and peripheral hardware. The following three kinds of system clocks and clock oscillators are selectable.

(1) Main system clock

<1> X1 oscillator

- ★ This circuit oscillates a clock of $f_x = 1$ to 20 MHz by connecting a resonator to X1 and X2. Oscillation can be stopped by executing the STOP instruction or using the main OSC control register (MOC).

<2> Internal high-speed oscillator

This circuit oscillates a clock of $f_{RH} = 8$ MHz (TYP.). After a reset release, the CPU always starts operating with this internal high-speed oscillation clock. Oscillation can be stopped by executing the STOP instruction or using the internal oscillation mode register (RCM).

- ★ An external main system clock ($f_{EXCLK} = 1$ to 20 MHz) can also be supplied from the EXCLK/X2/P122 pin. An external main system clock input can be disabled by executing the STOP instruction or using RCM. As the main system clock, a high-speed system clock (X1 clock or external main system clock) or internal high-speed oscillation clock can be selected by using the main clock mode register (MCM).

(2) Subsystem clock

• Subsystem clock oscillator

This circuit oscillates at a frequency of $f_{XT} = 32.768$ kHz by connecting a 32.768 kHz resonator across XT1 and XT2. Oscillation can be stopped by using the processor clock control register (PCC) and clock operation mode select register (OSCCTL).

An external subsystem clock ($f_{EXCLKS} = 32.768$ kHz) can also be supplied from the EXCLKS/XT2/P124 pin. An external subsystem clock input can be disabled by setting PCC and OSCCTL.

- Remarks**
1. f_x : X1 clock oscillation frequency
 2. f_{RH} : Internal high-speed oscillation clock frequency
 3. f_{EXCLK} : External main system clock frequency
 4. f_{XT} : XT1 clock oscillation frequency
 5. f_{EXCLKS} : External subsystem clock frequency

(3) Internal low-speed oscillation clock (clock for watchdog timer)

• **Internal low-speed oscillator**

This circuit oscillates a clock of $f_{RL} = 240 \text{ kHz}$ (TYP.). After a reset release, the internal low-speed oscillation clock always starts operating.

★ Oscillation can be stopped by using the internal oscillation mode register (RCM) when “internal low-speed oscillator can be stopped by software” is set by option byte.

The internal low-speed oscillation clock cannot be used as the CPU clock. The following hardware operates with the internal low-speed oscillation clock.

- Watchdog timer
- TMH1 (when f_{RL} , $f_{RL}/2^7$, or $f_{RL}/2^9$ is selected)

Remark f_{RL} : Internal low-speed oscillation clock frequency

6.2 Configuration of Clock Generator

The clock generator includes the following hardware.

Table 6-1. Configuration of Clock Generator

Item	Configuration
Control registers	Clock operation mode select register (OSCCTL) Processor clock control register (PCC) Internal oscillation mode register (RCM) Main OSC control register (MOC) Main clock mode register (MCM) Oscillation stabilization time counter status register (OSTC) Oscillation stabilization time select register (OSTS)
Oscillators	X1 oscillator XT1 oscillator Internal high-speed oscillator Internal low-speed oscillator

★ Figure 6-1. Block Diagram of Clock Generator

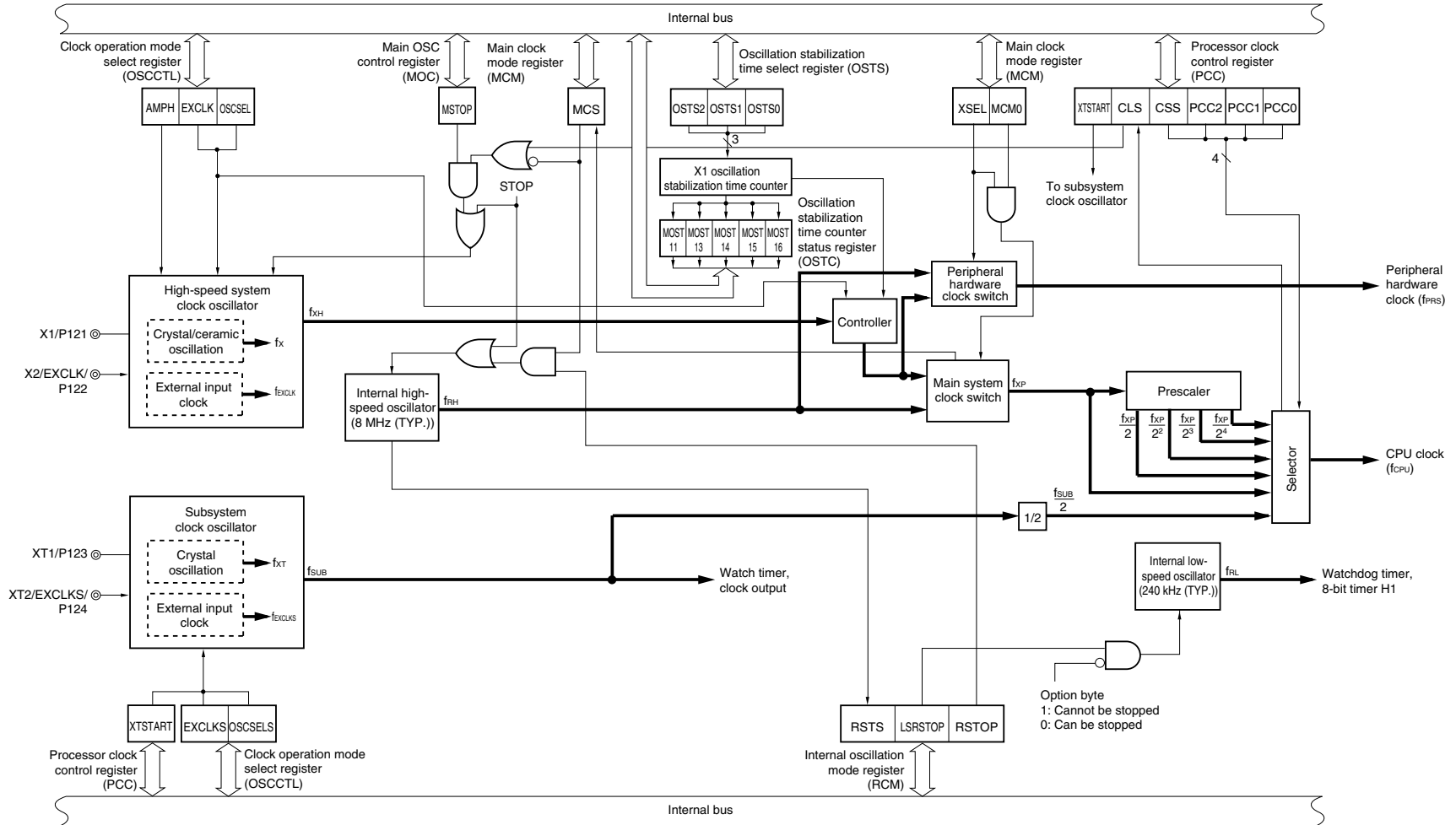

- Remarks**
1. f_X : X1 clock oscillation frequency
 2. f_{RH} : Internal high-speed oscillation clock frequency
 3. f_{EXCLK} : External main system clock frequency
 4. f_{XH} : High-speed system clock oscillation frequency
 5. f_{XP} : Main system clock oscillation frequency
 6. f_{PRS} : Peripheral hardware clock oscillation frequency
 7. f_{CPU} : CPU clock oscillation frequency
 8. f_{XT} : XT1 clock oscillation frequency
 9. f_{EXCLKS} : External subsystem clock frequency
 10. f_{SUB} : Subsystem clock oscillation frequency
 11. f_{RL} : Internal low-speed oscillation clock frequency

6.3 Registers Controlling Clock Generator

The following seven registers are used to control the clock generator.

- Clock operation mode select register (OSCCTL)
- Processor clock control register (PCC)
- Internal oscillation mode register (RCM)
- Main OSC control register (MOC)
- Main clock mode register (MCM)
- Oscillation stabilization time counter status register (OSTC)
- Oscillation stabilization time select register (OSTS)

(1) Clock operation mode select register (OSCCTL)

This register selects the operation modes of the high-speed system and subsystem clocks, and the gain of the on-chip oscillator.

OSCCTL can be set by a 1-bit or 8-bit memory manipulation instruction.

Reset signal generation sets this register to 00H.

Figure 6-2. Format of Clock Operation Mode Select Register (OSCCTL)

Address: FF9FH After reset: 00H R/W

Symbol	<7>	<6>	<5>	<4>	3	2	1	<0>
OSCCTL	EXCLK	OSCSEL	EXCLKS ^{Note}	OSCSELS ^{Note}	0	0	0	AMPH

EXCLK	OSCSEL	High-speed system clock pin operation mode	P121/X1 pin	P122/X2/EXCLK pin
0	0	I/O port mode	I/O port	
0	1	X1 oscillation mode	Crystal/ceramic resonator connection	
1	0	I/O port mode	I/O port	
1	1	External clock input mode	I/O port	External clock input

AMPH	Operating frequency control
0	1 MHz ≤ f _{XH} ≤ 10 MHz
1	10 MHz < f _{XH} ≤ 20 MHz

Note EXCLKS and OSCSELS are used in combination with XTSTART (bit 6 of the processor clock control register (PCC)). See (3) **Setting of operation mode for subsystem clock pin.**

- Cautions**
1. Be sure to set AMPH to 1 if the high-speed system clock oscillation frequency exceeds 10 MHz.
 2. Set AMPH before setting the peripheral functions after a reset release. The value of AMPH can be changed only once after a reset release. The clock supply to the CPU is stopped for 5 μs (MIN.) after AMPH has been set to 1.
 3. If the STOP instruction is executed with AMPH set to 1 when the internal high-speed oscillation clock or external main system clock is used as the CPU clock, then the clock supply to the CPU is stopped for 5 μs (MIN.) after the STOP mode has been released. If the X1 clock is used as the CPU clock, oscillation stabilization time is counted after the STOP mode has been released.
 4. To change the value of EXCLK and OSCSEL, be sure to confirm that bit 7 (MSTOP) of the main OSC control register (MOC) is 1 (the X1 oscillator stops or the external clock from the EXCLK pin is disabled).

Remark f_{XH}: High-speed system clock oscillation frequency

(2) Processor clock control register (PCC)

This register is used to select the CPU clock, the division ratio, and operation mode for subsystem clock. PCC is set by a 1-bit or 8-bit memory manipulation instruction. Reset signal generation sets PCC to 01H.

★

Figure 6-3. Format of Processor Clock Control Register (PCC)

Address: FFFBH After reset: 01H R/W^{Note 1}

Symbol	7	6	<5>	<4>	3	2	1	0
PCC	0	XTSTART ^{Note2}	CLS	CSS	0	PCC2	PCC1	PCC0

CLS	CPU clock status
0	Main system clock
1	Subsystem clock

CSS	PCC2	PCC1	PCC0	CPU clock (f _{CPU}) selection
0	0	0	0	f _{XP}
	0	0	1	f _{XP} /2 (default)
	0	1	0	f _{XP} /2 ²
	0	1	1	f _{XP} /2 ³
	1	0	0	f _{XP} /2 ⁴
1	0	0	0	f _{SUB} /2
	0	0	1	
	0	1	0	
	0	1	1	
	1	0	0	
Other than above				Setting prohibited

Notes 1. Bit 5 is read-only.

2. XTSTART is used in combination with EXCLKS and OSCSELS (bits 5 and 4 of the Clock operation mode select register (OSCCTL)). See (3) **Setting of operation mode for subsystem clock pin.**

Caution Be sure to clear bits 3 and 7 to 0.

- Remarks**
1. f_{XP}: Main system clock oscillation frequency
 2. f_{SUB}: Subsystem clock oscillation frequency

The fastest instruction can be executed in 2 clocks of the CPU clock in the 78K0/KE2. Therefore, the relationship between the CPU clock (f_{CPU}) and the minimum instruction execution time is as shown in Table 6-2.

Table 6-2. Relationship Between CPU Clock and Minimum Instruction Execution Time

CPU Clock (f_{CPU})	Minimum Instruction Execution Time: $2/f_{CPU}$			
	Main System Clock			Subsystem Clock
	High-Speed System Clock ^{Note}		Internal High-Speed Oscillation Clock ^{Note}	
	At 10 MHz Operation	At 20 MHz Operation	At 8 MHz (TYP.) Operation	At 32.768 kHz Operation
f_{XP}	0.2 μs	0.1 μs	0.25 μs (TYP.)	–
$f_{XP}/2$	0.4 μs	0.2 μs	0.5 μs (TYP.)	–
$f_{XP}/2^2$	0.8 μs	0.4 μs	1.0 μs (TYP.)	–
$f_{XP}/2^3$	1.6 μs	0.8 μs	2.0 μs (TYP.)	–
$f_{XP}/2^4$	3.2 μs	1.6 μs	4.0 μs (TYP.)	–
$f_{SUB}/2$	–		–	122.1 μs

Note The main clock mode register (MCM) is used to set the main system clock supplied to CPU clock (high-speed system clock/internal high-speed oscillation clock) (see **Figure 6-6**).

(3) Setting of operation mode for subsystem clock pin

The operation mode for the subsystem clock pin can be set by using bit 6 (XTSTART) of the processor clock control register (PCC) and bits 5 and 4 (EXCLKS, OSCSELS) of the clock operation mode select register (OSCCTL) in combination.

Table 6-3. Setting of Operation Mode for Subsystem Clock Pin

PCC OSCCTL

(4) Internal oscillation mode register (RCM)

This register sets the operation mode of internal oscillator.

RCM can be set by a 1-bit or 8-bit memory manipulation instruction.

Reset signal generation sets this register to 80H^{Note 1}.

Figure 6-4. Format of Internal Oscillation Mode Register (RCM)

Address: FFA0H After reset: 80H^{Note 1} R/W^{Note 2}

Symbol	<7>	6	5	4	3	2	<1>	<0>
RCM	RSTS	0	0	0	0	0	LSRSTOP	RSTOP

RSTS	Status of internal high-speed oscillator
0	Waiting for accuracy stabilization of internal high-speed oscillator
1	Stability operating of internal high-speed oscillator

LSRSTOP	Internal low-speed oscillator oscillating/stopped
0	Internal low-speed oscillator oscillating
1	Internal low-speed oscillator stopped

RSTOP	Internal high-speed oscillator oscillating/stopped
0	Internal high-speed oscillator oscillating
1	Internal high-speed oscillator stopped

Notes 1. The value of this register is 00H immediately after a reset release but automatically changes to 80H after internal high-speed oscillator has been stabilized.

2. Bit 7 is read-only.

Caution When setting RSTOP to 1, be sure to confirm that the CPU operates with a clock other than the internal high-speed oscillation clock. Specifically, set under either of the following conditions.

- When MCS = 1 (when CPU operates with the high-speed system clock)
- When CLS = 1 (when CPU operates with the subsystem clock)

In addition, stop peripheral hardware that is operating on the internal high-speed oscillation clock before setting RSTOP to 1.

(5) Main OSC control register (MOC)

This register selects the operation mode of the high-speed system clock.

This register is used to stop the X1 oscillator or to disable an external clock input from the EXCLK pin when the CPU operates with a clock other than the high-speed system clock.

MOC can be set by a 1-bit or 8-bit memory manipulation instruction.

Reset signal generation sets this register to 80H.

Figure 6-5. Format of Main OSC Control Register (MOC)

Address: FFA2H After reset: 80H R/W

Symbol	<7>	6	5	4	3	2	1	0
MOC	MSTOP	0	0	0	0	0	0	0

MSTOP	Control of high-speed system clock operation	
	X1 oscillation mode	External clock input mode
0	X1 oscillator operating	External clock from EXCLK pin is enabled
1	X1 oscillator stopped	External clock from EXCLK pin is disabled

- Cautions**
- When setting MSTOP to 1, be sure to confirm that the CPU operates with a clock other than the high-speed system clock. Specifically, set under either of the following conditions.
 - When MCS = 0 (when CPU operates with the internal high-speed oscillation clock)
 - When CLS = 1 (when CPU operates with the subsystem clock)
 In addition, stop peripheral hardware that is operating on the high-speed system clock before setting MSTOP to 1.
 - Do not clear MSTOP to 0 while bit 6 (OSCSEL) of the clock operation mode select register (OSCCTL) is 0 (I/O port mode).
 - The peripheral hardware cannot operate when the peripheral hardware clock is stopped. To resume the operation of the peripheral hardware after the peripheral hardware clock has been stopped, initialize the peripheral hardware.

(6) Main clock mode register (MCM)

This register selects the main system clock supplied to CPU clock and clock supplied to peripheral hardware clock.

MCM can be set by a 1-bit or 8-bit memory manipulation instruction.

Reset signal generation sets this register to 00H.

Figure 6-6. Format of Main Clock Mode Register (MCM)

Address: FFA1H After reset: 00H R/W^{Note}

Symbol	7	6	5	4	3	<2>	<1>	<0>
MCM	0	0	0	0	0	XSEL	MCS	MCM0

XSEL	MCM0	Selection of clock supplied to main system clock and peripheral hardware	
		Main system clock (f _{XP})	Peripheral hardware clock (f _{PRS})
0	0	Internal high-speed oscillation clock (f _{RH})	Internal high-speed oscillation clock (f _{RH})
0	1		Internal high-speed oscillation clock (f _{RH})
1	0	High-speed system clock (f _{XH})	High-speed system clock (f _{XH})
1	1		High-speed system clock (f _{XH})

MCS	Main system clock status
0	Operates with internal high-speed oscillation clock
1	Operates with high-speed system clock

Note Bit 1 is read-only.

Cautions 1. XSEL can be changed only once after a reset release.

2. A clock other than f_{PRS} is supplied to the following peripheral functions regardless of the setting of XSEL and MCM0.

- Watchdog timer (operates with internal low-speed oscillation clock)
- When “f_{R1}”, “f_{R1}/2⁷”, or “f_{R1}/2⁹” is selected as the count clock for 8-bit timer H1 (operates with internal low-speed oscillation clock)
- Peripheral hardware selects the external clock as the clock source (Except when the external count clock of TM0n (n = 0, 1) is selected (T100n pin valid edge))

(7) Oscillation stabilization time counter status register (OSTC)

This is the register that indicates the count status of the X1 clock oscillation stabilization time counter. When X1 clock oscillation starts with the internal high-speed oscillation clock or subsystem clock used as the CPU clock, the X1 clock oscillation stabilization time can be checked.

OSTC can be read by a 1-bit or 8-bit memory manipulation instruction.

When reset is released (reset by $\overline{\text{RESET}}$ input, POC, LVI, and WDT), the STOP instruction and MSTOP (bit 7 of the MOC register) = 1 clear OSTC to 00H.

Figure 6-7. Format of Oscillation Stabilization Time Counter Status Register (OSTC)

Address: FFA3H After reset: 00H R

Symbol	7	6	5	4	3	2	1	0
OSTC	0	0	0	MOST11	MOST13	MOST14	MOST15	MOST16

MOST11	MOST13	MOST14	MOST15	MOST16	Oscillation stabilization time status	
					fx = 10 MHz	fx = 20 MHz
1	0	0	0	0	$2^{11}/f_x$ min.	204.8 μs min.
1	1	0	0	0	$2^{13}/f_x$ min.	819.2 μs min.
1	1	1	0	0	$2^{14}/f_x$ min.	1.64 ms min.
1	1	1	1	0	$2^{15}/f_x$ min.	3.27 ms min.
1	1	1	1	1	$2^{16}/f_x$ min.	6.55 ms min.

- Cautions**
1. After the above time has elapsed, the bits are set to 1 in order from MOST11 and remain 1.
 2. The oscillation stabilization time counter counts up to the oscillation stabilization time set by OSTC. If the STOP mode is entered and then released while the internal high-speed oscillation clock is being used as the CPU clock, set the oscillation stabilization time as follows.
 - Desired OSTC oscillation stabilization time \leq Oscillation stabilization time set by OSTC

Note, therefore, that only the status up to the oscillation stabilization time set by OSTC is set to OSTC after STOP mode is released.
 3. The X1 clock oscillation stabilization wait time does not include the time until clock oscillation starts (“a” below).

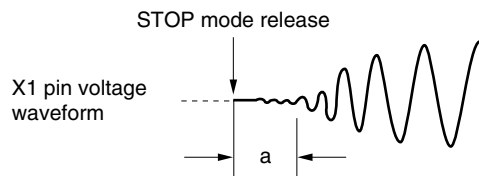

Remark fx: X1 clock oscillation frequency

(8) Oscillation stabilization time select register (OSTS)

This register is used to select the X1 clock oscillation stabilization wait time when the STOP mode is released. When the X1 clock is selected as the CPU clock, the operation waits for the time set using OSTS after the STOP mode is released.

★ When the internal high-speed oscillation clock is selected as the CPU clock, confirm with OSTC that the desired oscillation stabilization time has elapsed after the STOP mode is released. The oscillation stabilization time can be checked up to the time set using OSTC.

OSTS can be set by an 8-bit memory manipulation instruction.

Reset signal generation sets OSTS to 05H.

Figure 6-8. Format of Oscillation Stabilization Time Select Register (OSTS)

Address: FFA4H After reset: 05H R/W

Symbol	7	6	5	4	3	2	1	0
OSTS	0	0	0	0	0	OSTS2	OSTS1	OSTS0

OSTS2	OSTS1	OSTS0	Oscillation stabilization time selection	Oscillation stabilization time selection	
				$f_x = 10 \text{ MHz}$	$f_x = 20 \text{ MHz}$
0	0	1	$2^{11}/f_x$	204.8 μs	102.4 μs
0	1	0	$2^{13}/f_x$	819.2 μs	409.6 μs
0	1	1	$2^{14}/f_x$	1.64 ms	819.2 μs
1	0	0	$2^{15}/f_x$	3.27 ms	1.64 ms
1	0	1	$2^{16}/f_x$	6.55 ms	3.27 ms
Other than above			Setting prohibited		

- Cautions**
- To set the STOP mode when the X1 clock is used as the CPU clock, set OSTS before executing the STOP instruction.**
 - Do not change the value of the OSTS register during the X1 clock oscillation stabilization time.**
 - The oscillation stabilization time counter counts up to the oscillation stabilization time set by OSTS. If the STOP mode is entered and then released while the internal high-speed oscillation clock is being used as the CPU clock, set the oscillation stabilization time as follows.**
 - Desired OSTC oscillation stabilization time \leq Oscillation stabilization time set by OSTS**

Note, therefore, that only the status up to the oscillation stabilization time set by OSTS is set to OSTC after STOP mode is released.
 - The X1 clock oscillation stabilization wait time does not include the time until clock oscillation starts (“a” below).**

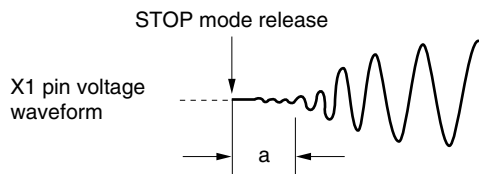

Remark f_x : X1 clock oscillation frequency

6.4 System Clock Oscillator

6.4.1 X1 oscillator

- ★ The X1 oscillator oscillates with a crystal resonator or ceramic resonator (1 to 20 MHz) connected to the X1 and X2 pins.

Figure 6-9 shows an example of the external circuit of the X1 oscillator.

Figure 6-9. Example of External Circuit of X1 Oscillator (Crystal or Ceramic Oscillation)

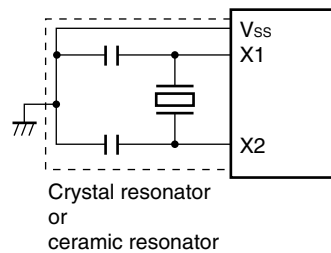

Cautions are listed on the next page.

6.4.2 XT1 oscillator

The XT1 oscillator oscillates with a crystal resonator (standard: 32.768 kHz) connected to the XT1 and XT2 pins.

Figure 6-10 shows an example of the external circuit of the XT1 oscillator.

Figure 6-10. Example of External Circuit of XT1 Oscillator (Crystal Oscillation)

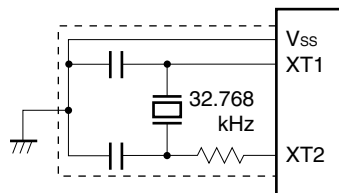

Cautions are listed on the next page.

Cautions 1. When using the X1 oscillator and XT1 oscillator, wire as follows in the area enclosed by the broken lines in the Figures 6-9 and 6-10 to avoid an adverse effect from wiring capacitance.

- Keep the wiring length as short as possible.
- Do not cross the wiring with the other signal lines. Do not route the wiring near a signal line through which a high fluctuating current flows.
- Always make the ground point of the oscillator capacitor the same potential as V_{ss} . Do not ground the capacitor to a ground pattern through which a high current flows.
- Do not fetch signals from the oscillator.

Note that the XT1 oscillator is designed as a low-amplitude circuit for reducing power consumption.

Figure 6-11 shows examples of incorrect resonator connection.

Figure 6-11. Examples of Incorrect Resonator Connection (1/2)

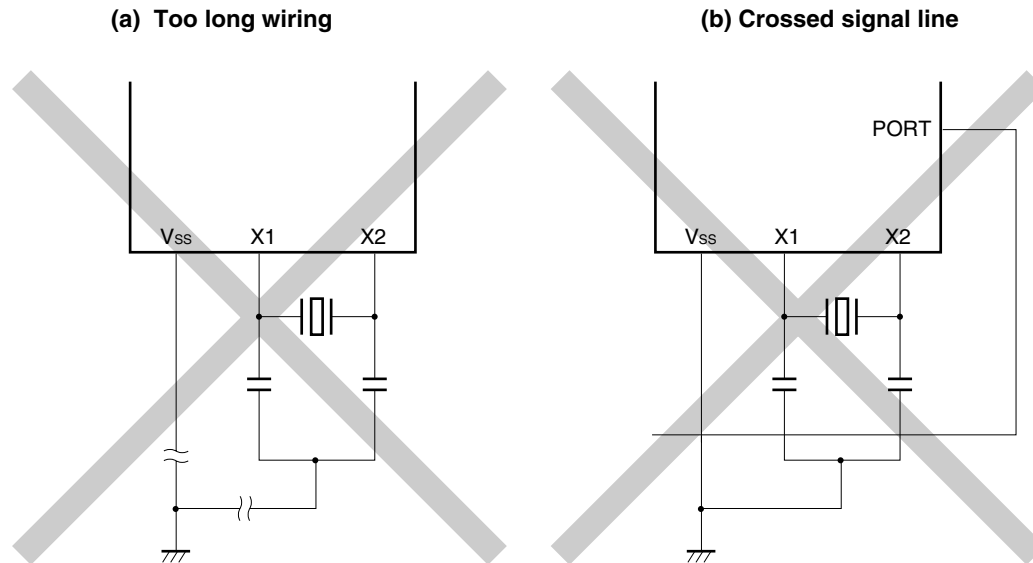

Remark When using the subsystem clock, replace X1 and X2 with XT1 and XT2, respectively. Also, insert resistors in series on the XT2 side.

Figure 6-11. Examples of Incorrect Resonator Connection (2/2)

(c) Wiring near high alternating current

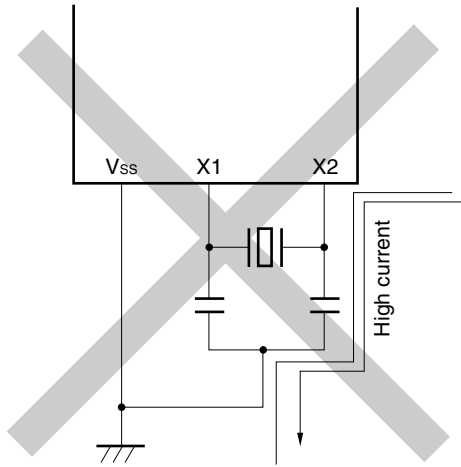

(d) Current flowing through ground line of oscillator (potential at points A, B, and C fluctuates)

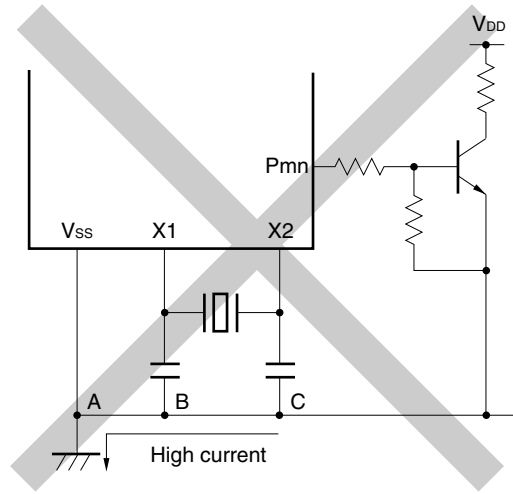

(e) Signals are fetched

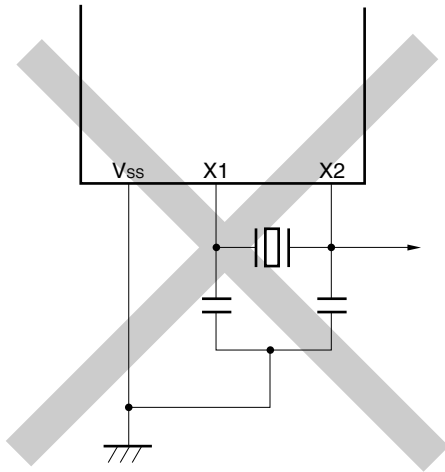

Remark When using the subsystem clock, replace X1 and X2 with XT1 and XT2, respectively. Also, insert resistors in series on the XT2 side.

Cautions 2. When X2 and XT1 are wired in parallel, the crosstalk noise of X2 may increase with XT1, resulting in malfunctioning.

6.4.3 When subsystem clock is not used

- ★ If it is not necessary to use the subsystem clock for low power consumption operations, or if not using the subsystem clock as an I/O port, set the XT1 and XT2 pins to I/O mode (OSCSELS = 0) and connect them as follows.

- ★ Input (PM123/PM124 = 1): Independently connect to V_{DD} or V_{SS} via a resistor.
Output (PM123/PM124 = 0): Leave open.

Remark OSCSELS: Bit 4 of clock operation mode select register (OSCCTL)
PM123, PM124: Bits 3 and 4 of port mode register 12 (PM12)

6.4.4 Internal high-speed oscillator

The internal high-speed oscillator is incorporated in the 78K0/KE2. Oscillation can be controlled by the internal oscillation mode register (RCM).

After a reset release, the internal high-speed oscillator automatically starts oscillation (8 MHz (TYP.)).

6.4.5 Internal low-speed oscillator

The internal low-speed oscillator is incorporated in the 78K0/KE2.

The internal low-speed oscillation clock is only used as the watchdog timer and the clock of 8-bit timer H1. The internal low-speed oscillation clock cannot be used as the CPU clock.

“Can be stopped by software” or “Cannot be stopped” can be selected by the option byte. When “Can be stopped by software” is set, oscillation can be controlled by the internal oscillation mode register (RCM).

After a reset release, the internal low-speed oscillator automatically starts oscillation, and the watchdog timer is driven (240 kHz (TYP.)) if the watchdog timer operation is enabled using the option byte.

6.4.6 Prescaler

The prescaler generates various clocks by dividing the main system clock when the main system clock is selected as the clock to be supplied to the CPU.

6.5 Clock Generator Operation

The clock generator generates the following clocks and controls the operation modes of the CPU, such as standby mode (see **Figure 6-1**).

- Main system clock f_{XP}
 - High-speed system clock f_{XH}
 - X1 clock f_X
 - External main system clock f_{EXCLK}
 - Internal high-speed oscillation clock f_{RH}
- Subsystem clock f_{SUB}
 - XT1 clock f_{XT}
 - External subsystem clock f_{EXCLKS}
- Internal low-speed oscillation clock f_{RL}
- CPU clock f_{CPU}
- Peripheral hardware clock f_{PRS}

The CPU starts operation when the internal high-speed oscillator starts outputting after a reset release in the 78K0/KE2, thus enabling the following.

(1) Enhancement of security function

When the X1 clock is set as the CPU clock by the default setting, the device cannot operate if the X1 clock is damaged or badly connected and therefore does not operate after reset is released. However, the start clock of the CPU is the internal high-speed oscillation clock, so the device can be started by the internal high-speed oscillation clock after a reset release. Consequently, the system can be safely shut down by performing a minimum operation, such as acknowledging a reset source by software or performing safety processing when there is a malfunction.

(2) Improvement of performance

Because the CPU can be started without waiting for the X1 clock oscillation stabilization time, the total performance can be improved.

When the power supply voltage is turned on, the clock generator operation is shown in Figure 6-12.

★ **Figure 6-12. Clock Generator Operation When Power Supply Voltage Is Turned On
(When 1.59 V POC Mode Is Set (Option Byte: POCMODE = 0))**

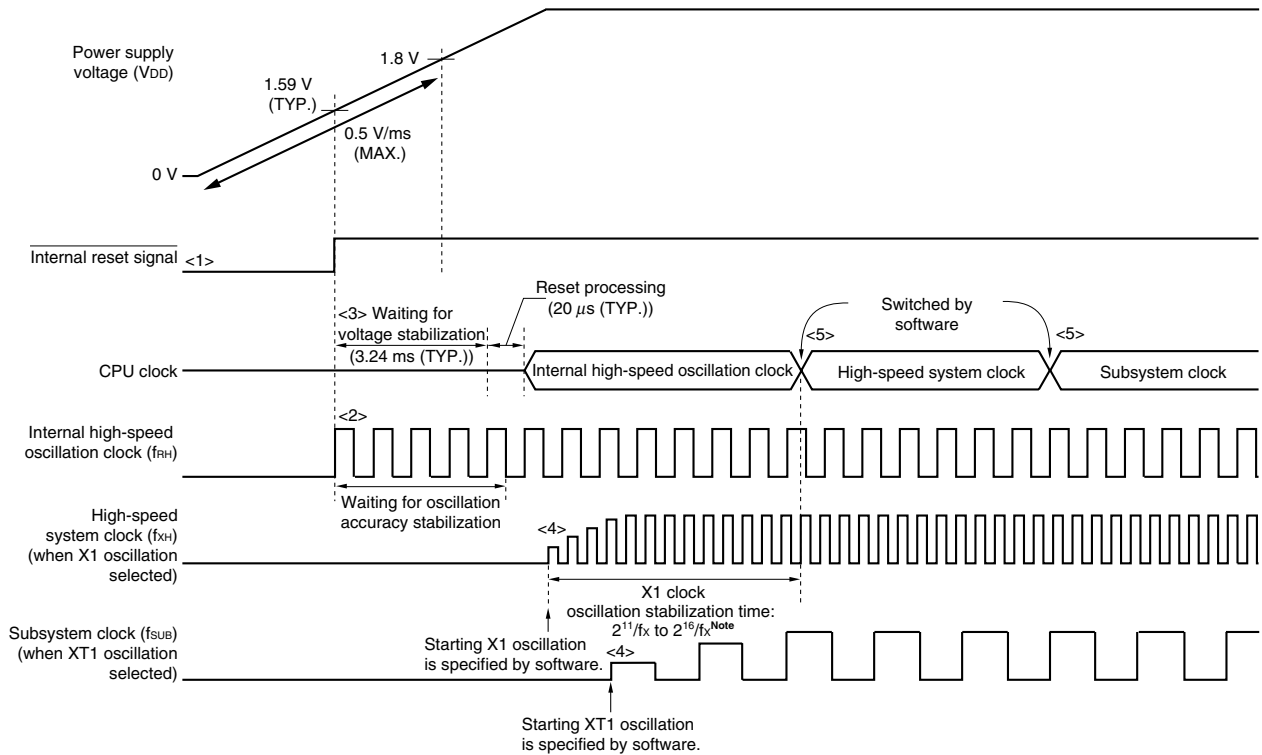

- <1> When the power is turned on, an internal reset signal is generated by the power-on-clear (POC) circuit.
- <2> When the power supply voltage exceeds 1.59 V (TYP.), the reset is released and the internal high-speed oscillator automatically starts oscillation.
- <3> When the power supply voltage rises with a slope of 0.5 V/ms (MAX.), the CPU starts operation on the internal high-speed oscillation clock after the reset is released and after the stabilization times for the voltage of the power supply and regulator have elapsed, and then reset processing is performed.
- <4> Set the start of oscillation of the X1 or XT1 clock via software (see (1) in 6.6.1 Example of controlling high-speed system clock and (1) in 6.6.3 Example of controlling subsystem clock).
- <5> When switching the CPU clock to the X1 or XT1 clock, wait for the clock oscillation to stabilize, and then set switching via software (see (3) in 6.6.1 Example of controlling high-speed system clock and (3) in 6.6.3 Example of controlling subsystem clock).

Note When releasing a reset (above figure) or releasing STOP mode while the CPU is operating on the internal high-speed oscillation clock, confirm the oscillation stabilization time for the X1 clock using the oscillation stabilization time counter status register (OSTC). If the CPU operates on the high-speed system clock (X1 oscillation), set the oscillation stabilization time when releasing STOP mode using the oscillation stabilization time select register (OSTS).

- Cautions**
1. If the voltage rises with a slope of less than 0.5 V/ms (MAX.) from power application until the voltage reaches 1.8 V, input a low level to the $\overline{\text{RESET}}$ pin from power application until the voltage reaches 1.8 V, or set the 2.7 V/1.59 V POC mode by using the option byte (POCMODE = 1) (see Figure 6-13). By doing so, the CPU operates with the same timing as <2> and thereafter in Figure 6-12 after reset release by the $\overline{\text{RESET}}$ pin.
 2. It is not necessary to wait for the oscillation stabilization time when an external clock input from the EXCLK and EXCLKS pins is used.

Remark While the microcontroller is operating, a clock that is not used as the CPU clock can be stopped via software settings. The internal high-speed oscillation clock and high-speed system clock can be stopped by executing the STOP instruction (see (4) in 6.6.1 Example of controlling high-speed system clock, (3) in 6.6.2 Example of controlling internal high-speed oscillation clock, and (4) in 6.6.3 Example of controlling subsystem clock).

★ **Figure 6-13. Clock Generator Operation When Power Supply Voltage Is Turned On**
(When 2.7 V/1.59 V POC Mode Is Set (Option Byte: POCMODE = 1))

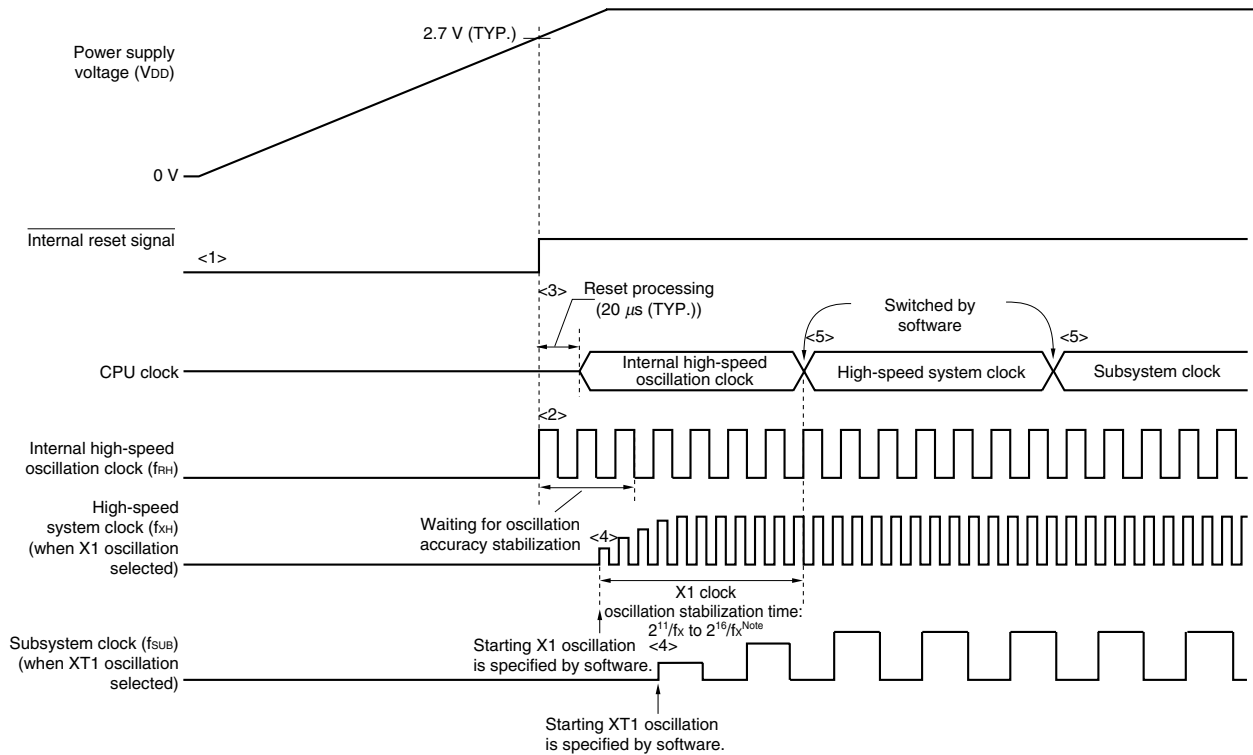

- <1> When the power is turned on, an internal reset signal is generated by the power-on-clear (POC) circuit.
- <2> When the power supply voltage exceeds 2.7 V (TYP.), the reset is released and the internal high-speed oscillator automatically starts oscillation.
- <3> After the reset is released and reset processing is performed, the CPU starts operation on the internal high-speed oscillation clock.
- <4> Set the start of oscillation of the X1 or XT1 clock via software (see (1) in 6.6.1 Example of controlling high-speed system clock and (1) in 6.6.3 Example of controlling subsystem clock).
- <5> When switching the CPU clock to the X1 or XT1 clock, wait for the clock oscillation to stabilize, and then set switching via software (see (3) in 6.6.1 Example of controlling high-speed system clock and (3) in 6.6.3 Example of controlling subsystem clock).

Note When releasing a reset (above figure) or releasing STOP mode while the CPU is operating on the internal high-speed oscillation clock, confirm the oscillation stabilization time for the X1 clock using the oscillation stabilization time counter status register (OSTC). If the CPU operates on the high-speed system clock (X1 oscillation), set the oscillation stabilization time when releasing STOP mode using the oscillation stabilization time select register (OSTS).

Caution It is not necessary to wait for the oscillation stabilization time when an external clock input from the EXCLK and EXCLKS pins is used.

Remark While the microcontroller is operating, a clock that is not used as the CPU clock can be stopped via software settings. The internal high-speed oscillation clock and high-speed system clock can be stopped by executing the STOP instruction (see (4) in 6.6.1 Example of controlling high-speed system clock, (3) in 6.6.2 Example of controlling internal high-speed oscillation clock, and (4) in 6.6.3 Example of controlling subsystem clock).

6.6 Controlling Clock

★ 6.6.1 Controlling high-speed system clock

The following two types of high-speed system clocks are available.

- X1 clock: Crystal/ceramic resonator is connected across the X1 and X2 pins.
- External main system clock: External clock is input to the EXCLK pin.

When the high-speed system clock is not used, the X1/P121 and X2/EXCLK/P122 pins can be used as I/O port pins.

Caution The X1/P121 and X2/EXCLK/P122 pins are in the I/O port mode after a reset release.

The following describes examples of setting procedures for the following cases.

- (1) When oscillating X1 clock
- (2) When using external main system clock
- (3) When using high-speed system clock as CPU clock and peripheral hardware clock
- (4) When stopping high-speed system clock

(1) Example of setting procedure when oscillating the X1 clock

<1> Setting frequency (OSCCTL register)

Using AMPH, set the gain of the on-chip oscillator according to the frequency to be used.

AMPH ^{Note}	Operating Frequency Control
0	1 MHz ≤ f _{XH} ≤ 10 MHz
1	10 MHz < f _{XH} ≤ 20 MHz

Note Set AMPH before setting the peripheral functions after a reset release. The value of AMPH can be changed only once after a reset release. When AMPH is set to 1, the clock supply to the CPU is stopped for 5 μs (MIN.).

Remark f_{XH}: High-speed system clock oscillation frequency

<2> Setting P121/X1 and P122/X2/EXCLK pins and selecting X1 clock or external clock (OSCCTL register)

When EXCLK is cleared to 0 and OSCSEL is set to 1, the mode is switched from port mode to X1 oscillation mode.

EXCLK	OSCSEL	Operation Mode of High-Speed System Clock Pin	P121/X1 Pin	P122/X2/EXCLK Pin
0	1	X1 oscillation mode	Crystal/ceramic resonator connection	

<3> Controlling oscillation of X1 clock (MOC register)

If MSTOP is cleared to 0, the X1 oscillator starts oscillating.

- <4> Waiting for the stabilization of the oscillation of X1 clock
 Check the OSTC register and wait for the necessary time.
 During the wait time, other software processing can be executed with the internal high-speed oscillation clock.

- Cautions**
1. Do not change the value of EXCLK and OSCSEL while the X1 clock is operating.
 2. Set the X1 clock after the supply voltage has reached the operable voltage of the clock to be used (see CHAPTER 29 ELECTRICAL SPECIFICATIONS (TARGET)).

(2) Example of setting procedure when using the external main system clock

- <1> Setting frequency (OSCCTL register)
 Using AMPH, set the frequency to be used.

AMPH ^{Note}	Operating Frequency Control
0	1 MHz ≤ f _{XH} ≤ 10 MHz
1	10 MHz < f _{XH} ≤ 20 MHz

Note Set AMPH before setting the peripheral functions after a reset release. The value of AMPH can be changed only once after a reset release. When AMPH is set to 1, the clock supply to the CPU is stopped for 5 μs (MIN.).

Remark f_{XH}: High-speed system clock oscillation frequency

- <2> Setting P121/X1 and P122/X2/EXCLK pins and selecting operation mode (OSCCTL register)
 When EXCLK and OSCSEL are set to 1, the mode is switched from port mode to external clock input mode.

EXCLK	OSCSEL	Operation Mode of High-Speed System Clock Pin	P121/X1 Pin	P122/X2/EXCLK Pin
1	1	External clock input mode	I/O port	External clock input

- <3> Controlling external main system clock input (MOC register)
 When MSTOP is cleared to 0, the input of the external main system clock is enabled.

- Cautions**
1. Do not change the value of EXCLK and OSCSEL while the external main system clock is operating.
 2. Set the external main system clock after the supply voltage has reached the operable voltage of the clock to be used (see CHAPTER 29 ELECTRICAL SPECIFICATIONS (TARGET)).

(3) Example of setting procedure when using high-speed system clock as CPU clock and peripheral hardware clock

- <1> Setting high-speed system clock oscillation^{Note}
 (See 6.6.1 (1) Example of setting procedure when oscillating the X1 clock and (2) Example of setting procedure when using the external main system clock.)

Note The setting of <1> is not necessary when high-speed system clock is already operating.

<2> Setting the high-speed system clock as the main system clock (MCM register)

When XSEL and MCM0 are set to 1, the high-speed system clock is supplied as the main system clock and peripheral hardware clock.

XSEL	MCM0	Selection of Main System Clock and Clock Supplied to Peripheral Hardware	
		Main System Clock (f_{XP})	Peripheral Hardware Clock (f_{PRS})
1	1	High-speed system clock (f_{XH})	High-speed system clock (f_{XH})

Caution If the high-speed system clock is selected as the main system clock, a clock other than the high-speed system clock cannot be set as the peripheral hardware clock.

<3> Setting the main system clock as the CPU clock and selecting the division ratio (PCC register)

When CSS is cleared to 0, the main system clock is supplied to the CPU. To select the CPU clock division ratio, use PCC0, PCC1, and PCC2.

CSS	PCC2	PCC1	PCC0	CPU Clock (f_{CPU}) Selection
0	0	0	0	f_{XP}
	0	0	1	$f_{XP}/2$ (default)
	0	1	0	$f_{XP}/2^2$
	0	1	1	$f_{XP}/2^3$
	1	0	0	$f_{XP}/2^4$
	Other than above			

(4) Example of setting procedure when

(b) To stop X1 oscillation (disabling external clock input) by setting MSTOP to 1

<1> Confirming the CPU clock status (PCC and MCM registers)

Confirm with CLS and MCS that the CPU is operating on a clock other than the high-speed system clock.

When CLS = 0 and MCS = 1, the high-speed system clock is supplied to the CPU, so change the CPU clock to the subsystem clock or internal high-speed oscillation clock.

CLS	MCS	CPU Clock Status
0	0	Internal high-speed oscillation clock
0	1	High-speed system clock
1	×	Subsystem clock

<2> Stopping the high-speed system clock (MOC register)

When MSTOP is set to 1, X1 oscillation is stopped (the input of the external clock is disabled).

Caution Be sure to confirm that MCS = 0 or CLS = 1 when setting MSTOP to 1. In addition, stop peripheral hardware that is operating on the high-speed system clock.

★ 6.6.2 Example of controlling internal high-speed oscillation clock

The following describes examples of clock setting procedures for the following cases.

- (1) When restarting oscillation of the internal high-speed oscillation clock
- (2) When using internal high-speed oscillation clock as CPU clock, and internal high-speed oscillation clock or high-speed system clock as peripheral hardware clock
- (3) When stopping the internal high-speed oscillation clock

(1) Example of setting procedure when restarting oscillation of the internal high-speed oscillation clock^{Note 1}

<1> Setting restart of oscillation of the internal high-speed oscillation clock (RCM register)

When RSTOP is cleared to 0, the internal high-speed oscillation clock starts operating.

<2> Waiting for the oscillation accuracy stabilization time of internal high-speed oscillation clock (RCM register)

Wait until RSTS is set to 1^{Note 2}.

Notes 1. After a reset release, the internal high-speed oscillator automatically starts oscillating and the internal high-speed oscillation clock is selected as the CPU clock.

2. This wait time is not necessary if high accuracy is not necessary for the CPU clock and peripheral hardware clock.

(2) Example of setting procedure when using internal high-speed oscillation clock as CPU clock, and internal high-speed oscillation clock or high-speed system clock as peripheral hardware clock

- <1> • Restarting oscillation of the internal high-speed oscillation clock^{Note}
 (See 6.6.2 (1) **Example of setting procedure when restarting internal high-speed oscillation clock**).
- Oscillating the high-speed system clock^{Note}
 (This setting is required when using the high-speed system clock as the peripheral hardware clock. See 6.6.1 (1) **Example of setting procedure when oscillating the X1 clock** and (2) **Example of setting procedure when using the external main system clock**.)

Note The setting of <1> is not necessary when the internal high-speed oscillation clock or high-speed system clock is already operating.

- <2> Selecting the clock supplied as the main system clock and peripheral hardware clock (MCM register)
 Set the main system clock and peripheral hardware clock using XSEL and MCM0.

XSEL	MCM0	Selection of Main System Clock and Clock Supplied to Peripheral Hardware	
		Main System Clock (f_{XP})	Peripheral Hardware Clock (f_{PRS})
0	0	Internal high-speed oscillation clock (f_{RH})	Internal high-speed oscillation clock (f_{RH})
0	1		High-speed system clock (f_{XH})
1	0		High-speed system clock (f_{XH})

- <3> Selecting the CPU clock division ratio (PCC register)
 When CSS is cleared to 0, the main system clock is supplied to the CPU. To select the CPU clock division ratio, use PCC0, PCC1, and PCC2.

CSS	PCC2	PCC1	PCC0	CPU Clock (f_{CPU}) Selection
0	0	0	0	f_{XP}
	0	0	1	$f_{XP}/2$ (default)
	0	1	0	$f_{XP}/2^2$
	0	1	1	$f_{XP}/2^3$
	1	0	0	$f_{XP}/2^4$
	Other than above			

(3) Example of setting procedure when stopping the internal high-speed oscillation clock

The internal high-speed oscillation clock can be stopped in the following two ways.

- Executing the STOP instruction to set the STOP mode
- Setting RSTOP to 1 and stopping the internal high-speed oscillation clock

(a) To execute a STOP instruction

- <1> Setting of peripheral hardware
 Stop peripheral hardware that cannot be used in the STOP mode (for peripheral hardware that cannot be used in STOP mode, see **CHAPTER 21 STANDBY FUNCTION**).
- <2> Setting the X1 clock oscillation stabilization time after standby release
 When the CPU is operating on the X1 clock, set the value of the OSTS register before the STOP instruction is executed.
- <3> Executing the STOP instruction
 When the STOP instruction is executed, the system is placed in

(b) To stop internal high-speed oscillation clock by setting RSTOP to 1

<1> Confirming the CPU clock status (PCC and MCM registers)

Confirm with CLS and MCS that the CPU is operating on a clock other than the internal high-speed oscillation clock.

When CLS = 0 and MCS = 0, the internal high-speed oscillation clock is supplied to the CPU, so change the CPU clock to the high-speed system clock or subsystem clock.

CLS	MCS	CPU Clock Status
0	0	Internal high-speed oscillation clock
0	1	High-speed system clock
1	×	Subsystem clock

<2> Stopping the internal high-speed oscillation clock (RCM register)

When RSTOP is set to 1, internal high-speed oscillation clock is stopped.

Caution Be sure to confirm that MCS = 1 or CLS = 1 when setting RSTOP to 1. In addition, stop peripheral hardware that is operating on the internal high-speed oscillation clock.

★ 6.6.3 Example of controlling subsystem clock

The following two types of subsystem clocks are available.

- XT1 clock: Crystal/ceramic resonator is connected across the XT1 and XT2 pins.
- External subsystem clock: External clock is input to the EXCLKS pin.

When the subsystem clock is not used, the XT1/P123 and XT2/EXCLKS/P124 pins can be used as I/O port pins.

Caution The XT1/P123 and XT2/EXCLKS/P124 pins are in the I/O port mode after a reset release.

The following describes examples of setting procedures for the following cases.

- (1) When oscillating XT1 clock
- (2) When using external subsystem clock
- (3) When using subsystem clock as CPU clock
- (4) When stopping subsystem clock

(1) Example of setting procedure when oscillating the XT1 clock

<1> Setting XT1 and XT2 pins and selecting operation mode (PCC and OSCCTL registers)

When XTSTART, EXCLKS, and OSCSELS are set as any of the following, the mode is switched from port mode to XT1 oscillation mode.

XTSTART	EXCLKS	OSCSELS	Operation Mode of Subsystem Clock Pin	P123/XT1 Pin	P124/XT2/EXCLKS Pin
0	0	1	XT1 oscillation mode	Crystal/ceramic resonator connection	
1	×	×			

Remark ×: don't care

<2> Waiting for the stabilization of the subsystem clock oscillation

Wait for the oscillation stabilization time of the subsystem clock by software, using a timer function.

Caution Do not change the value of XTSTART, EXCLKS, and OSCSELS while the subsystem clock is operating.

(2) Example of setting procedure when using the external subsystem clock

<1> Setting XT1 and XT2 pins, selecting XT1 clock/external clock and controlling oscillation (PCC and OSCCTL registers)

When XTSTART is cleared to 0 and EXCLKS and OSCSELS are set to 1, the mode is switched from port mode to external clock input mode. In this case, input the external clock to the EXCLKS/XT2/P124 pins.

XTSTART	EXCLKS	OSCSELS	Operation Mode of Subsystem Clock Pin	P123/XT1 Pin	P124/XT2/EXCLKS Pin
0	1	1	External clock input mode	I/O port	External clock input

Caution Do not change the value of XTSTART, EXCLKS, and OSCSELS while the subsystem clock is operating.

(3) Example of setting procedure when using the subsystem clock as the CPU clock

<1> Setting subsystem clock oscillation^{Note}

(See 6.6.3 (1) Example of setting procedure when oscillating the XT1 clock and (2) Example of setting procedure when using the external subsystem clock.)

Note The setting of <1> is not necessary when while the subsystem clock is operating.

<2> Switching the CPU clock (PCC register)

When CSS is set to 1, the subsystem clock is supplied to the CPU.

CSS	PCC2	PCC1	PCC0	CPU Clock (f _{cpu}) Selection
1	0	0	0	f _{sub} /2
	0	0	1	
	0	1	0	
	0	1	1	
	1	0	0	
	Other than above			Setting prohibited

(4) Example of setting procedure when stopping the subsystem clock

<1> Confirming the CPU clock status (PCC and MCS registers)

Confirm with CLS and MCS that the CPU is operating on a clock other than the subsystem clock.

When CLS = 1, the subsystem clock is supplied to the CPU, so change the CPU clock to the internal high-speed oscillation clock or high-speed system clock.

CLS	MCS	CPU Clock Status
0	0	Internal high-speed oscillation clock
0	1	High-speed system clock
1	×	Subsystem clock

<2> Stopping the subsystem clock (OSCCTL register)

When OSCSELS is cleared to 0, XT1 oscillation is stopped (the input of the external clock is disabled).

Caution1. Be sure to confirm that CLS = 0 when clearing OSCSELS to 0. In addition, stop the watch timer if it is operating on the subsystem clock.

2. The subsystem clock oscillation cannot be stopped using the STOP instruction.

6.6.4 Example of controlling internal low-speed oscillation clock

The internal low-speed oscillation clock cannot be used as the CPU clock.

Only the following peripheral hardware can operate with this clock.

- Watchdog timer
- 8-bit timer H1 (if f_{RL} is selected as the count clock)

In addition, the following operation modes can be selected by the option byte.

- Internal low-speed oscillator cannot be stopped
- Internal low-speed oscillator can be stopped by software

The internal low-speed oscillator automatically starts oscillation after a reset release, and the watchdog timer is driven (240 kHz (TYP.)) if the watchdog timer operation has been enabled by the option byte.

(1) Example of setting procedure when stopping the internal low-speed oscillation clock

<1> Setting LSRSTOP to 1 (RCM register)

When LSRSTOP is set to 1, the internal low-speed oscillation clock is stopped.

(2) Example of setting procedure when restarting oscillation of the internal low-speed oscillation clock

<1> Clearing LSRSTOP to 0 (RCM register)

When LSRSTOP is cleared to 0, the internal low-speed oscillation clock is restarted.

Caution If “Internal low-speed oscillator cannot be stopped” is selected by the option byte, oscillation of the internal low-speed oscillation clock cannot be controlled.

6.6.5 Clocks supplied to CPU and peripheral hardware

The following table shows the relation among the clocks supplied to the CPU and peripheral hardware, and setting of registers.

★ **Table 6-4. Clocks Supplied to CPU and Peripheral Hardware, and Register Setting**

Supplied Clock		XSEL	CSS	MCM0	EXCLK
Clock Supplied to CPU	Clock Supplied to Peripheral Hardware				
Internal high-speed oscillation clock		0	0	×	×
Internal high-speed oscillation clock	X1 clock	1	0	0	0
	External main system clock	1	0	0	1
X1 clock		1	0	1	0
External main system clock		1	0	1	1
Subsystem clock	Internal high-speed oscillation clock	0	1	×	×
	X1 clock	1	1	0	0
		1	1	1	0
	External main system clock	1	1	0	1
1		1	1	1	

- Remarks**
1. XSEL: Bit 2 of the main clock mode register (MCM)
 2. CSS: Bit 4 of the processor clock control register (PCC)
 3. MCM0: Bit 0 of MCM
 4. EXCLK: Bit 7 of the clock operation mode select register (OSCCTL)
 5. ×: don't care

6.6.6 CPU clock status transition diagram

Figure 6-14 shows the CPU clock status transition diagram of this product.

**Figure 6-14. CPU Clock Status Transition Diagram
(When 1.59 V POC Mode Is Set (Option Byte: POCMODE = 0))**

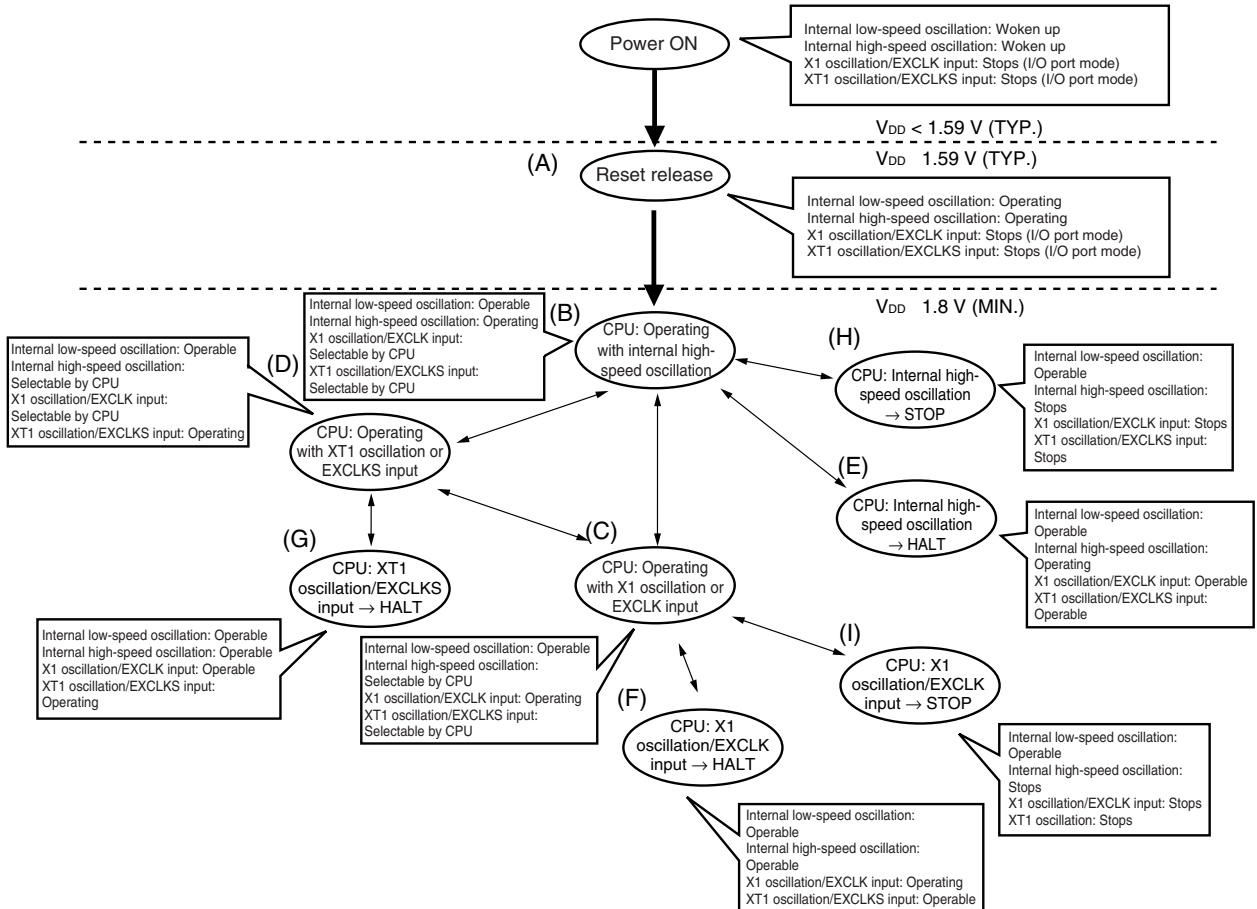

★ **Remark** In the 2.7 V/1.59 V POC mode (option byte: POCMODE = 1), the CPU clock status changes to (A) in the above figure when the supply voltage exceeds 2.7 V (TYP.), and to (B) after reset processing (20 μ s (TYP.)).

Table 6-5 shows transition of the CPU clock and examples of setting the SFR registers.

Table 6-5. CPU Clock Transition and SFR Register Setting Examples (1/4)

(1) CPU operating with internal high-speed oscillation clock (B) after reset release (A)

Status Transition	SFR Register Setting
(A) → (B)	SFR registers do not have to be set (default status after reset release).

(2) CPU operating with high-speed system clock (C) after reset release (A)

(The CPU operates with the internal high-speed oscillation clock immediately after a reset release (B).)

(Setting sequence of SFR registers) →

Setting Flag of SFR Register Status Transition	AMPH	EXCLK	OSCSEL	MSTOP	OSTC Register	XSEL	MCM0
(A) → (B) → (C) (X1 clock: $1 \text{ MHz} \leq f_{XH} \leq 10 \text{ MHz}$)	0	0	1	0	Must be checked	1	1
(A) → (B) → (C) (external main clock: $1 \text{ MHz} \leq f_{XH} \leq 10 \text{ MHz}$)	0	1	1	0	Must not be checked	1	1
(A) → (B) → (C) (X1 clock: $10 \text{ MHz} < f_{XH} \leq 20 \text{ MHz}$)	1	0	1	0	Must be checked	1	1
(A) → (B) → (C) (external main clock: $10 \text{ MHz} < f_{XH} \leq 20 \text{ MHz}$)	1	1	1	0	Must not be checked	1	1

Caution Set the clock after the supply voltage has reached the operable voltage of the clock to be set (see CHAPTER 29 ELECTRICAL SPECIFICATIONS (TARGET)).

★ (3) CPU operating with subsystem clock (D) after reset release (A)

(The CPU operates with the internal high-speed oscillation clock immediately after a reset release (B).)

(Setting sequence of SFR registers) →

Setting Flag of SFR Register Status Transition	XTSTART	EXCLKS	OSCSELS	Waiting for Oscillation Stabilization	CSS
(A) → (B) → (D) (XT1 clock)	0	0	1	Necessary	1
	1	×	×		
(A) → (B) → (D) (external subsystem clock)	0	1	1	Unnecessary	1

Remarks 1. (A) to (I) in Table 6-5 correspond to (A) to (I) in Figure 6-14.

2. EXCLK, OSCSEL, EXCLKS, OSCSELS, AMPH:

Bits 7 to 4 and 0 of the clock operation mode select register (OSCCTL)

MSTOP: Bit 7 of the main OSC control register (MOC)

XSEL, MCM0: Bits 2 and 0 of the main clock mode register (MCM)

XTSTART, CSS: Bits 6 and 4 of the processor clock control register (PCC)

×: Don't care

Table 6-5. CPU Clock Transition and SFR Register Setting Examples (2/4)

★ (4) CPU clock changing from internal high-speed oscillation clock (B) to high-speed system clock (C)

(Setting sequence of SFR registers) →

Setting Flag of SFR Register	AMPH ^{Note}	EXCLK	OSCSEL	MSTOP	OSTC Register	XSEL ^{Note}	MCM0
Status Transition							
(B) → (C) (X1 clock: $1 \text{ MHz} \leq f_{XH} \leq 10 \text{ MHz}$)	0	0	1	0	Must be checked	1	1
(B) → (C) (external main clock: $1 \text{ MHz} \leq f_{XH} \leq 10 \text{ MHz}$)	0	1	1	0	Must not be checked	1	1
(B) → (C) (X1 clock: $10 \text{ MHz} < f_{XH} \leq 20 \text{ MHz}$)	1	0	1	0	Must be checked	1	1
(B) → (C) (external main clock: $10 \text{ MHz} < f_{XH} \leq 20 \text{ MHz}$)	1	1	1	0	Must not be checked	1	1

Unnecessary if these registers are already set
 Unnecessary if the CPU is operating with the high-speed system clock

Note The value of this flag can be changed only once after a reset release. This setting is not necessary if it has already been set.

Caution Set the clock after the supply voltage has reached the operable voltage of the clock to be set (see CHAPTER 29 ELECTRICAL SPECIFICATIONS (TARGET)).

★ (5) CPU clock changing from internal high-speed oscillation clock (B) to subsystem clock (D)

(Setting sequence of SFR registers) →

Setting Flag of SFR Register	XTSTART	EXCLKS	OSCSELS	Waiting for Oscillation Stabilization	CSS
Status Transition					
(B) → (D) (XT1 clock)	0	0	1	Necessary	1
	1	×	×		
(B) → (D) (external subsystem clock)	0	1	1	Unnecessary	1

Unnecessary if the CPU is operating with the subsystem clock

Remarks 1. (A) to (I) in Table 6-5 correspond to (A) to (I) in Figure 6-14.

2. EXCLK, OSCSEL, EXCLKS, OSCSELS, AMPH:

Bits 7 to 4 and 0 of the clock operation mode select register (OSCCTL)

MSTOP: Bit 7 of the main OSC control register (MOC)

XSEL, MCM0: Bits 2 and 0 of the main clock mode register (MCM)

XTSTART, CSS: Bits 6 and 4 of the processor clock control register (PCC)

×: Don't care

Table 6-5. CPU Clock Transition and SFR Register Setting Examples (3/4)

(6) CPU clock changing from high-speed system clock (C) to internal high-speed oscillation clock (B)

(Setting sequence of SFR registers) →

Setting Flag of SFR Register	RSTOP	RSTS	MCM0
Status Transition			
(C) → (B)	0	Confirm this flag is 1.	0

Unnecessary if the CPU is operating with the internal high-speed oscillation clock

★ (7) CPU clock changing from high-speed system clock (C) to subsystem clock (D)

(Setting sequence of SFR registers) →

Setting Flag of SFR Register	XTSTART	EXCLKS	OSCSELS	Waiting for Oscillation Stabilization	CSS
Status Transition					
(C) → (D) (XT1 clock)	0	0	1	Necessary	1
	1	×	×		
(C) → (D) (external subsystem clock)	0	1	1	Unnecessary	1

Unnecessary if the CPU is operating with the subsystem clock

(8) CPU clock changing from subsystem clock (D) to internal high-speed oscillation clock (B)

(Setting sequence of SFR registers) →

Setting Flag of SFR Register	RSTOP	RSTS	MCM0	CSS
Status Transition				
(D) → (B)	0	Confirm this flag is 1.	0	0

Unnecessary if the CPU is operating with the internal high-speed oscillation clock

↑ Unnecessary if XSEL is 0

Remarks 1. (A) to (I) in Table 6-5 correspond to (A) to (I) in Figure 6-14.

- 2. MCM0: Bit 0 of the main clock mode register (MCM)
- EXCLKS, OSCSELS: Bits 5 and 4 of the clock operation mode select register (OSCCTL)
- RSTS, RSTOP: Bits 7 and 0 of the internal oscillation mode register (RCM)
- XTSTART, CSS: Bits 6 and 4 of the processor clock control register (PCC)
- ×: Don't care

Table 6-5. CPU Clock Transition and SFR Register Setting Examples (4/4)

★ (9) CPU clock changing from subsystem clock (D) to high-speed system clock (C)

(Setting sequence of SFR registers) →

Setting Flag of SFR Register Status Transition	AMPH ^{Note}	EXCLK	OSCSEL	MSTOP	OSTC Register	XSEL ^{Note}	MCM0	CSS
(D) → (C) (X1 clock: 1 MHz ≤ f _{XH} ≤ 10 MHz)	0	0	1	0	Must be checked	1	1	0
(D) → (C) (external main clock: 1 MHz ≤ f _{XH} ≤ 10 MHz)	0	1	1	0	Must not be checked	1	1	0
(D) → (C) (X1 clock: 10 MHz < f _{XH} ≤ 20 MHz)	1	0	1	0	Must be checked	1	1	0
(D) → (C) (external main clock: 10 MHz < f _{XH} ≤ 20 MHz)	1	1	1	0	Must not be checked	1	1	0

Unnecessary if these registers are already set
Unnecessary if the CPU is operating with the high-speed system clock
Unnecessary if this register is already set

Note The value of this flag can be changed only once after a reset release. This setting is not necessary if it has already been set.

Caution Set the clock after the supply voltage has reached the operable voltage of the clock to be set (see CHAPTER 29 ELECTRICAL SPECIFICATIONS (TARGET)).

- (10) • HALT mode (E) set while CPU is operating with internal high-speed oscillation clock (B)
- HALT mode (F) set while CPU is operating with high-speed system clock (C)
 - HALT mode (G) set while CPU is operating with subsystem clock (D)

Status Transition	Setting
(B) → (E) (C) → (F) (D) → (G)	Executing HALT instruction

- (11) • STOP mode (H) set while CPU is operating with internal high-speed oscillation clock (B)
- STOP mode (I) set while CPU is operating with high-speed system clock (C)

(Setting sequence) →

Status Transition	Setting
(B) → (H) (C) → (I)	Stopping peripheral functions that cannot operate in STOP mode Executing STOP instruction

- Remarks**
1. (A) to (I) in Table 6-5 correspond to (A) to (I) in Figure 6-14.
 2. EXCLK, OSCSEL, AMPH: Bits 7, 6 and 0 of the clock operation mode select register (OSCCTL)
 MSTOP: Bit 7 of the main OSC control register (MOC)
 XSEL, MCM0: Bits 2 and 0 of the main clock mode register (MCM)
 CSS: Bit 4 of the processor clock control register (PCC)

6.6.7 Condition before changing CPU clock and processing after changing CPU clock

Condition before changing the CPU clock and processing after changing the CPU clock are shown below.

★

Table 6-6. Changing CPU Clock

CPU Clock		Condition Before Change	Processing After Change
Before Change	After Change		
Internal high-speed oscillation clock	X1 clock	Stabilization of X1 oscillation • MSTOP = 0, OSCSEL = 1, EXCLK = 0 • After elapse of oscillation stabilization time	<ul style="list-style-type: none"> Internal high-speed oscillator can be stopped (RSTOP = 1). Clock supply to CPU is stopped for 5 μs (MIN.) after AMPH has been set to 1.
	External main system clock	Enabling input of external clock from EXCLK pin • MSTOP = 0, OSCSEL = 1, EXCLK = 1	
X1 clock	Internal high-speed oscillation clock	Oscillation of internal high-speed oscillator • RSTOP = 0	X1 oscillation can be stopped (MSTOP = 1).
External main system clock			External main system clock input can be disabled (MSTOP = 1).
Internal high-speed oscillation clock	XT1 clock	Stabilization of XT1 oscillation • XTSTART = 0, EXCLKS = 0, OSCSELS = 1, or XTSTART = 1 • After elapse of oscillation stabilization time	Operating current can be reduced by stopping internal high-speed oscillator (RSTOP = 1).
X1 clock			X1 oscillation can be stopped (MSTOP = 1).
External main system clock			External main system clock input can be disabled (MSTOP = 1).
Internal high-speed oscillation clock	External subsystem clock	Enabling input of external clock from EXCLKS pin • XTSTART = 0, EXCLKS = 1, OSCSELS = 1	Operating current can be reduced by stopping internal high-speed oscillator (RSTOP = 1).
X1 clock			X1 oscillation can be stopped (MSTOP = 1).
External main system clock			External main system clock input can be disabled (MSTOP = 1).
XT1 clock, external subsystem clock	Internal high-speed oscillation clock	Oscillation of internal high-speed oscillator and selection of internal high-speed oscillation clock as main system clock • RSTOP = 0, MCS = 0	XT1 oscillation can be stopped or external subsystem clock input can be disabled (OSCSELS = 0).
	X1 clock	Stabilization of X1 oscillation and selection of high-speed system clock as main system clock • MSTOP = 0, OSCSEL = 1, EXCLK = 0 • After elapse of oscillation stabilization time • MCS = 1	<ul style="list-style-type: none"> XT1 oscillation can be stopped or external subsystem clock input can be disabled (OSCSELS = 0). Clock supply to CPU is stopped for 5 μs (MIN.) after AMPH has been set to 1.
	External main system clock	Enabling input of external clock from EXCLK pin and selection of high-speed system clock as main system clock • MSTOP = 0, OSCSEL = 1, EXCLK = 1 • MCS = 1	

★ **6.6.8 Time required for switchover of CPU clock and main system clock**

By setting bits 0 to 2 (PCC0 to PCC2) and bit 4 (CSS) of the processor clock control register (PCC), the CPU clock can be switched (between the main system clock and the subsystem clock) and the division ratio of the main system clock can be changed.

The actual switchover operation is not performed immediately after rewriting to PCC; operation continues on the pre-switchover clock for several clocks (see **Table 6-7**).

Whether the CPU is operating on the main system clock or the subsystem clock can be ascertained using bit 5 (CLS) of the PCC register.

Table 6-7. Time Required for Switchover of CPU Clock and Main System Clock Cycle Division Factor

Set Value Before Switchover				Set Value After Switchover																							
CSS	PCC2	PCC1	PCC0	CSS	PCC2	PCC1	PCC0	CSS	PCC2	PCC1	PCC0	CSS	PCC2	PCC1	PCC0	CSS	PCC2	PCC1	PCC0	CSS	PCC2	PCC1	PCC0	CSS	PCC2	PCC1	PCC0
				0	0	0	0	0	0	0	1	0	0	1	0	0	0	1	1	0	1	0	0	1	×	×	×
0	0	0	0	/				16 clocks				16 clocks				16 clocks				16 clocks				2f _{XP} /f _{SUB} clocks			
	0	0	1					8 clocks				8 clocks				8 clocks				8 clocks				f _{XP} /f _{SUB} clocks			
	0	1	0					4 clocks				4 clocks				4 clocks				4 clocks				f _{XP} /2f _{SUB} clocks			
	0	1	1					2 clocks				2 clocks				2 clocks				2 clocks				f _{XP} /4f _{SUB} clocks			
	1	0	0					1 clock				1 clock				1 clock				1 clock				f _{XP} /8f _{SUB} clocks			
1	×	×	×	2 clocks				2 clocks				2 clocks				2 clocks				2 clocks							

Caution Selection of the main system clock cycle division factor (PCC0 to PCC2) and switchover from the main system clock to the subsystem clock (changing CSS from 0 to 1) should not be set simultaneously.

Simultaneous setting is possible, however, for selection of the main system clock cycle division factor (PCC0 to PCC2) and switchover from the subsystem clock to the main system clock (changing CSS from 1 to 0).

- Remarks**
1. The number of clocks listed in Table 6-7 is the number of CPU clocks before switchover.
 2. When switching the CPU clock from the subsystem clock to the main system clock, calculate the number of clocks by rounding up to the next clock and discarding the decimal portion, as shown below.

Example When switching CPU clock from f_{SUB}/2 to f_{XP}/2 (@ oscillation with f_{SUB} = 32.768 kHz, f_{XP} = 10 MHz)

$$f_{XP}/f_{SUB} = 10000/32.768 \cong 305.1 \rightarrow 306 \text{ clocks}$$

By setting bit 0 (MCM0) of the main clock mode register (MCM), the main system clock can be switched (between the internal high-speed oscillation clock and the high-speed system clock).

The actual switchover operation is not performed immediately after rewriting to MCM0; operation continues on the pre-switchover clock for several clocks (see **Table 6-8**).

Whether the CPU is operating on the internal high-speed oscillation clock or the high-speed system clock can be ascertained using bit 1 (MCS) of MCM.

Table 6-8. Maximum Time Required for Main System Clock Switchover

Set Value Before Switchover	Set Value After Switchover	
MCM0	MCM0	
	0	1
0		$1 + 2f_{RH}/f_{XH}$ clock
1	$1 + 2f_{XH}/f_{RH}$ clock	

Caution When switching the internal high-speed oscillation clock to the high-speed system clock, bit 2 (XSEL) of MCM must be set to 1 in advance. The value of XSEL can be changed only once after a reset release.

- Remarks**
1. The number of clocks listed in Table 6-8 is the number of main system clocks before switchover.
 2. Calculate the number of clocks in Table 6-8 by removing the decimal portion.

Example When switching the main system clock from the internal high-speed oscillation clock to the high-speed system clock (@ oscillation with $f_{RH} = 8$ MHz, $f_{XH} = 10$ MHz)

$$1 + 2f_{RH}/f_{XH} = 1 + 2 \times 8/10 = 1 + 2 \times 0.8 = 1 + 1.6 = 2.6 \rightarrow 2 \text{ clocks}$$

★ **6.6.9 Conditions before clock oscillation is stopped**

The following lists the register flag settings for stopping the clock oscillation (disabling external clock input) and conditions before the clock oscillation is stopped.

Table 6-9. Conditions Before the Clock Oscillation Is Stopped and Flag Settings

Clock	Conditions Before Clock Oscillation Is Stopped (External Clock Input Disabled)	Flag Settings of SFR Register
Internal high-speed oscillation clock	MCS = 1 or CLS = 1 (The CPU is operating on a clock other than the internal high-speed oscillation clock)	RSTOP = 1
X1 clock	MCS = 1 or CLS = 1 (The CPU is operating on a clock other than the high-speed system clock)	MSTOP = 1
External main system clock		
XT1 clock	CLS = 0 (The CPU is operating on a clock other than the subsystem clock)	OSCSELS = 0
External subsystem clock		

★ 6.6.10 Peripheral hardware and source clocks

The following lists peripheral hardware and source clocks incorporated in the 78K0/KE2.

Table 6-10. Peripheral Hardware and Source Clocks

Source Clock		Peripheral Hardware Clock (f _{PRS})	Subsystem Clock (f _{SUB})	Internal Low-Speed Oscillation Clock (f _{RL})	TM50 Output	External Clock from Peripheral Hardware Pins
16-bit timer/ event counter	00	Y	N	N	N	Y (T1000 pin) ^{Note}
	01	Y	N	N	N	Y (T1001 pin) ^{Note}
8-bit timer/ event counter	50	Y	N	N	N	Y (T150 pin) ^{Note}
	51	Y	N	N	N	Y (T151 pin) ^{Note}
8-Bit timer	H0	Y	N	N	Y	N
	H1	Y	N	Y	N	N
Watch timer		Y	Y	N	N	N
Watchdog timer		N	N	Y	N	N
Buzzer output		Y	N	N	N	N
Clock output		Y	Y	N	N	N
A/D converter		Y	N	N	N	N
Serial interface	UART0	Y	N	N	Y	N
	UART6	Y	N	N	Y	N
	CSI10	Y	N	N	N	Y (SCK10 pin) ^{Note}
	CSI11	Y	N	N	N	Y (SCK11 pin) ^{Note}
	IIC0	Y	N	N	N	Y (EXSCL0, SCL0 pin) ^{Note}

Note When the CPU is operating on the subsystem clock and the internal high-speed oscillation clock has been stopped, do not start operation of these functions on the external clock input from peripheral hardware pins.

Remark Y: Can be selected, N: Cannot be selected

The μ PD78F0531, 78F0532, and 78F0533 incorporate 16-bit timer/event counter 00, and the μ PD78F0534, 78F0535, 78F0536, 78F0537, and 78F0537D incorporate 16-bit timer/event counters 00 and 01.

7.1 Functions of 16-Bit Timer/Event Counters 00 and 01

16-bit timer/event counters 00 and 01^{Note} have the following functions.

(1) Interval timer

16-bit timer/event counters 00 and 01 generate an interrupt request at the preset time interval.

(2) Square-wave output

16-bit timer/event counters 00 and 01 can output a square wave with any selected frequency.

(3) External event counter

16-bit timer/event counters 00 and 01 can measure the number of pulses of an externally input signal.

(4) One-shot pulse output

16-bit timer event counters 00 and 01 can output a one-shot pulse whose output pulse width can be set freely.

(5) PPG output

16-bit timer/event counters 00 and 01 can output a rectangular wave whose frequency and output pulse width can be set freely.

(6) Pulse width measurement

16-bit timer/event counters 00 and 01 can measure the pulse width of an externally input signal.

Note Available only in the μ PD78F0534, 78F0535, 78F0536, 78F0537, and 78F0537D.

7.2 Configuration of 16-Bit Timer/Event Counters 00 and 01

16-bit timer/event counters 00 and 01 include the following hardware.

Table 7-1. Configuration of 16-Bit Timer/Event Counters 00 and 01

Item	Configuration
Time/counter	16-bit timer counter 0n (TM0n)
Register	16-bit timer capture/compare registers 00n, 01n (CR00n, CR01n)
Timer input	TI00n, TI01n pins
Timer output	TO0n pin, output controller
Control registers	16-bit timer mode control register 0n (TMC0n) 16-bit timer capture/compare control register 0n (CRC0n) 16-bit timer output control register 0n (TOC0n) Prescaler mode register 0n (PRM0n) Port mode register 0 (PM0) Port register 0 (P0)

Remark n = 0: μ PD78F0531, 78F0532, 78F0533

n = 0, 1: μ PD78F0534, 78F0535, 78F0536, 78F0537, 78F0537D

Figures 7-1 and 7-2 show the block diagrams.

Figure 7-1. Block Diagram of 16-Bit Timer/Event Counter 00

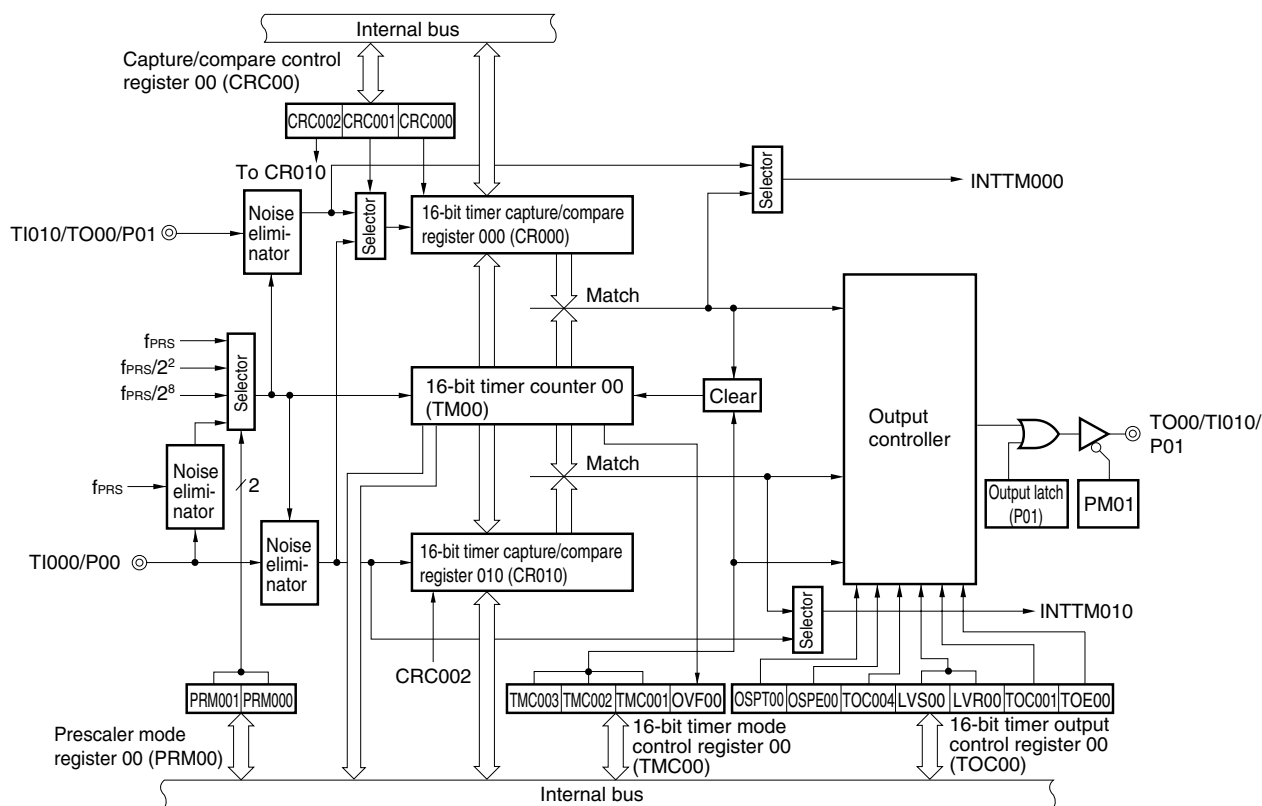
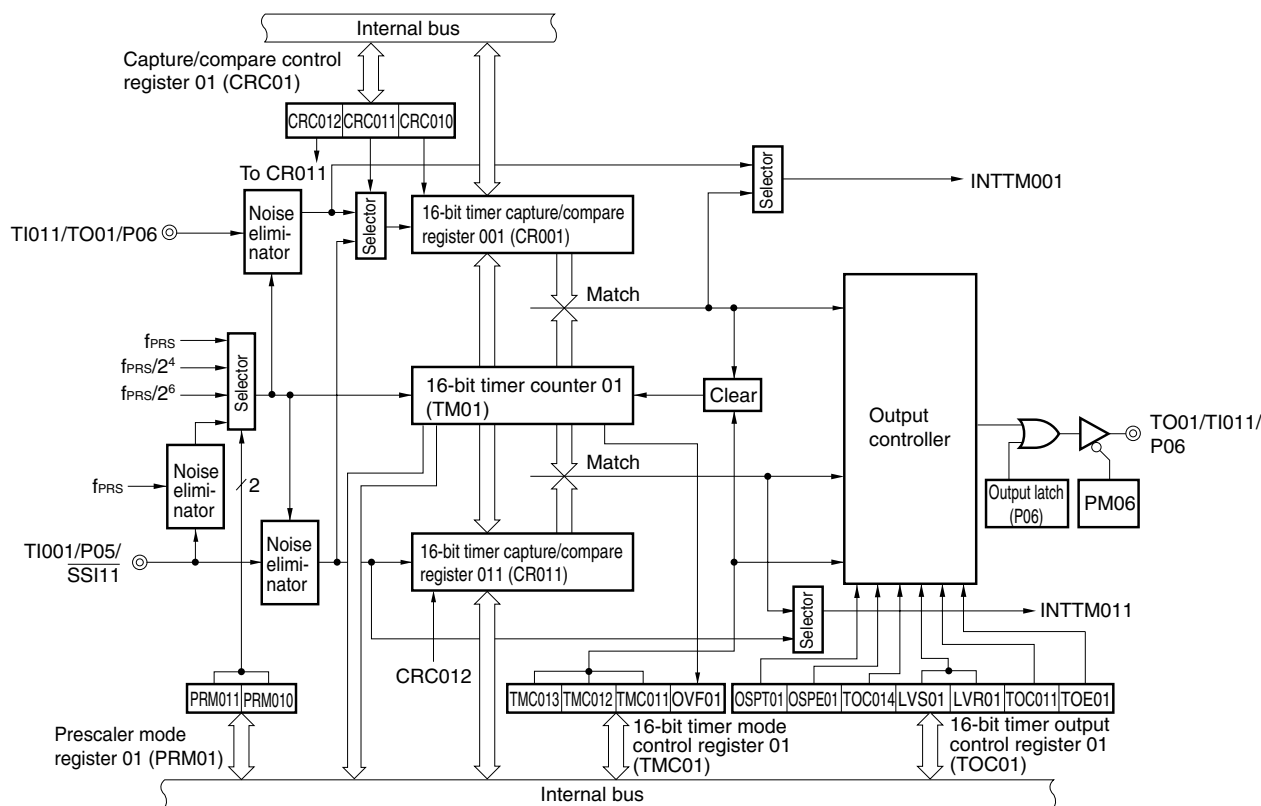

Figure 7-2. Block Diagram of 16-Bit Timer/Event Counter 01
(Available only in the μ PD78F0534, 78F0535, 78F0536, 78F0537, and 78F0537D)



(1) 16-bit timer counter 0n (TM0n)

TM0n is a 16-bit read-only register that counts count pulses.

The counter is incremented in synchronization with the rising edge of the count clock.

If the count value is read during operation, then input of the count clock is temporarily stopped, and the count value at that point is read.

Figure 7-3. Format of 16-Bit Timer Counter 0n (TM0n)

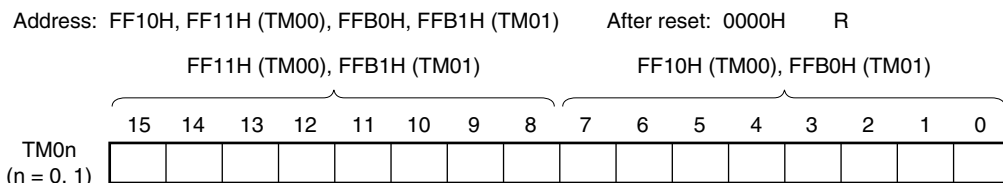

Remark n = 0: μ PD78F0531, 78F0532, 78F0533
n = 0, 1: μ PD78F0534, 78F0535, 78F0536, 78F0537, 78F0537D

The count value of TM0n can be read by reading TM0n when the value of bits 3 and 2 (TMC0n3 and TMC0n2) of 16-bit timer mode control register 0n (TMC0n) is other than 00. The value of TM0n is 0000H if it is read when TMC0n3 and TMC0n2 = 00.

The count value is reset to 0000H in the following cases.

- At reset signal generation
- If TMC0n3 and TMC0n2 are cleared to 00
- If the valid edge of the TI00n pin is input in the mode in which the clear & start occurs when inputting the valid edge to the TI00n pin
- If TM0n and CR00n match in the mode in which the clear & start occurs when TM0n and CR00n match
- OSPT0n is set to 1 in one-shot pulse output mode or the valid edge is input to the TI00n pin

Cautions

1. Even if TM0n is read, the value is not captured by CR01n.
2. When TM0n is read, input of the count clock is temporarily stopped and it is resumed after the timer has been read. Therefore, no clock miss occurs.

(2) 16-bit timer capture/compare register 00n (CR00n), 16-bit timer capture/compare register 01n (CR01n)

CR00n and CR01n are 16-bit registers that are used with a capture function or comparison function selected by using CRC0n.

Change the value of CR00n while the timer is stopped (TMC0n3 and TMC0n2 = 00).

The value of CR01n can be changed during operation if the value has been set in a specific way. For details, see **7.5.1 Rewriting CR01n during TM0n operation.**

These registers can be read or written in 16-bit units.

Reset signal generation sets these registers to 0000H.

Figure 7-4. Format of 16-Bit Timer Capture/Compare Register 00n (CR00n)

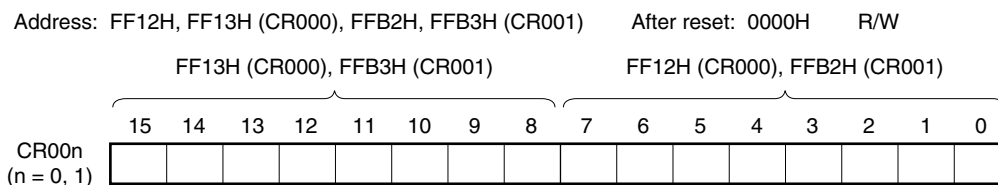

Remark n = 0: μ PD78F0531, 78F0532, 78F0533
n = 0, 1: μ PD78F0534, 78F0535, 78F0536, 78F0537, 78F0537D

(i) When CR00n is used as a compare register

The value set in CR00n is constantly compared with the TM0n count value, and an interrupt request signal (INTTM00n) is generated if they match. The value is held until CR00n is rewritten.

(ii) When CR00n is used as a capture register

The count value of TM0n is captured to CR00n when a capture trigger is input. As the capture trigger, an edge of a phase reverse to that of the TI00n pin or the valid edge of the TI01n pin can be selected by using CRC0n or PRM0n.

Figure 7-5. Format of 16-Bit Timer Capture/Compare Register 01n (CR01n)

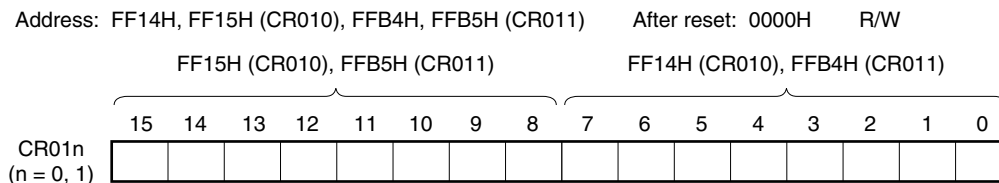

(i) When CR01n is used as a compare register

The value set in CR01n is constantly compared with the TM0n count value, and an interrupt request signal (INTTM01n) is generated if they match.







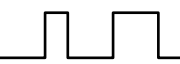

(ii) When CR01n is used as a capture register

The count value of TM0n is captured to CR01n when a capture trigger is input. It is possible to select the valid edge of the TI00n pin as the capture trigger. The TI00n pin valid edge is set by PRM0n.

- Cautions**
1. To use this register as a compare register, set a value other than 0000H to CR00n and CR01n.
 2. The valid edge of TI010 and timer output (TO00) cannot be used for the P01 pin at the same time, and the valid edge of TI011 and timer output (TO01) cannot be used for the P06 pin at the same time. Select either of the functions.
 3. If clearing of its 3 and 2 (TMC0n3 and TMC0n2) of 16-bit timer mode control register 0n (TMC0n) to 00 and input of the capture trigger conflict, then the captured data is undefined.
 4. To change the mode from the capture mode to the comparison mode, first clear the TMC0n3 and TMC0n2 bits to 00, and then change the setting.
A value that has been once captured remains stored in CR00n unless the device is reset. If the mode has been changed to the comparison mode, be sure to set a comparison value.
 5. CR00n/CR01n does not perform the capture operation when it is set in the comparison mode, even if a capture trigger is input to it.

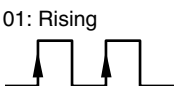
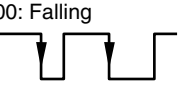
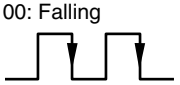
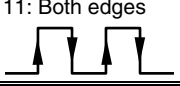
Remark n = 0: μ PD78F0531, 78F0532, 78F0533
n = 0, 1: μ PD78F0534, 78F0535, 78F0536, 78F0537, 78F0537D

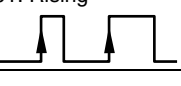
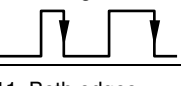
Table 7-2. Capture Operation of CR00n and CR01n

External Input Signal	TI00n Pin Input 		TI01n Pin Input 	
Capture operation of CR00n	CRC0n1 = 1 TI00n pin input (reverse phase) 	Set values of ES0n1 and ES0n0 Position of edge to be captured	CRC0n1 bit = 0 TI01n pin input 	Set values of ES1n1 and ES1n0 Position of edge to be captured
		01: Rising 		01: Rising 
		00: Falling 		00: Falling 
		11: Both edges (cannot be captured)		11: Both edges 
Interrupt signal	INTTM00n signal is not generated even if value is captured.	Interrupt signal	INTTM00n signal is generated each time value is captured.	
Capture operation of CR01n	TI00n pin input ^{Note} 	Set values of ES0n1 and ES0n0 Position of edge to be captured		
		01: Rising 		
		00: Falling 		
		11: Both edges 		
Interrupt signal	INTTM01n signal is generated each time value is captured.			

Note The capture operation of CR01n is not affected by the setting of the CRC0n1 bit.

Caution To capture the count value of the TM0n register to the CR00n register by using the phase reverse to that input to the TI00n pin, the interrupt request signal (INTTM00n) is not generated after the value has been captured. If the valid edge is detected on the TI01n pin during this operation, the capture operation is not performed but the INTTM00n signal is generated as an external interrupt signal. To not use the external interrupt, mask the INTTM00n signal.

- Remarks** 1. CRC0n1: See 7.3 (2) Capture/compare control register 0n (CRC0n).
 ES1n1, ES1n0, ES0n1, ES0n0: See 7.3 (4) Prescaler mode register 0n (PRM0n).
 2. n = 0: μ PD78F0531, 78F0532, 78F0533
 n = 0, 1: μ PD78F0534, 78F0535, 78F0536, 78F0537, 78F0537D

7.3 Registers Controlling 16-Bit Timer/Event Counters 00 and 01

Registers used to control 16-bit timer/event counters 00 and 01 are shown below.

- 16-bit timer mode control register 0n (TMC0n)
- Capture/compare control register 0n (CRC0n)
- 16-bit timer output control register 0n (TOC0n)
- Prescaler mode register 0n (PRM0n)
- Port mode register 0 (PM0)
- Port register 0 (P0)

(1) 16-bit timer mode control register 0n (TMC0n)

TMC0n is an 8-bit register that sets the 16-bit timer/event counter 0n operation mode, TM0n clear mode, and output timing, and detects an overflow.

Rewriting TMC0n is prohibited during operation (when TMC0n3 and TMC0n2 = other than 00). However, it can be changed when TMC0n3 and TMC0n2 are cleared to 00 (stopping operation) and when OVF0n is cleared to 0.

TMC0n can be set by a 1-bit or 8-bit memory manipulation instruction.

Reset signal generation sets TMC0n to 00H.

Caution 16-bit timer/event counter 0n starts operation at the moment TMC0n2 and TMC0n3 are set to values other than 00 (operation stop mode), respectively. Set TMC0n2 and TMC0n3 to 00 to stop the operation.

Remark n = 0: μ PD78F0531, 78F0532, 78F0533

n = 0, 1: μ PD78F0534, 78F0535, 78F0536, 78F0537, 78F0537D

Figure 7-6. Format of 16-Bit Timer Mode Control Register 00 (TMC00)

Address: FFBAH After reset: 00H R/W

Symbol	7	6	5	4	3	2	1	<0>
TMC00	0	0	0	0	TMC003	TMC002	TMC001	OVF00

TMC003	TMC002	Operation enable of 16-bit timer/event counter 00
0	0	Disables TM00 operation. Stops supplying operating clock. Asynchronously resets the internal circuit.
0	1	Free-running timer mode
1	0	Clear & start mode entered by TI000 pin valid edge input ^{Note}
1	1	Clear & start mode entered upon a match between TM00 and CR000

TMC001	Condition to reverse timer output (TO00)
0	<ul style="list-style-type: none"> Match between TM00 and CR000 or match between TM00 and CR010
1	<ul style="list-style-type: none"> Match between TM00 and CR000 or match between TM00 and CR010 Trigger input of TI000 pin valid edge

OVF00	TM00 overflow flag
Clear (0)	Clears OVF00 to 0 or TMC003 and TMC002 = 00
Set (1)	Overflow occurs.
OVF00 is set to 1 when the value of TM00 changes from FFFFH to 0000H in all the operation modes (free-running timer mode, clear & start mode entered by TI000 pin valid edge input, and clear & start mode entered upon a match between TM00 and CR000). It can also be set to 1 by writing 1 to OVF00.	

Note The TI000 pin valid edge is set by bits 5 and 4 (ES001, ES000) of prescaler mode register 00 (PRM00).

Figure 7-7. Format of 16-Bit Timer Mode Control Register 01 (TMC01)

Address: FFB6H After reset: 00H R/W

Symbol	7	6	5	4	3	2	1	<0>
TMC01	0	0	0	0	TMC013	TMC012	TMC011	OVF01

TMC013	TMC012	Operation enable of 16-bit timer/event counter 01
0	0	Disables TM01 operation. Stops supplying operating clock. Asynchronously resets the internal circuit.
0	1	Free-running timer mode
1	0	Clear & start mode entered by TI001 pin valid edge input ^{Note}
1	1	Clear & start mode entered upon a match between TM01 and CR001

TMC011	Condition to reverse timer output (TO01)
0	• Match between TM01 and CR001 or match between TM01 and CR011
1	• Match between TM01 and CR001 or match between TM01 and CR011 • Trigger input of TI001 pin valid edge

OVF01	TM01 overflow flag
Clear (0)	Clears OVF01 to 0 or TMC013 and TMC012 = 00
Set (1)	Overflow occurs.
OVF01 is set to 1 when the value of TM01 changes from FFFFH to 0000H in all the operation modes (free-running timer mode, clear & start mode entered by TI001 pin valid edge input, and clear & start mode entered upon a match between TM01 and CR001). It can also be set to 1 by writing 1 to OVF01.	

Note The TI001 pin valid edge is set by bits 5 and 4 (ES011, ES010) of prescaler mode register 01 (PRM01).

(2) Capture/compare control register 0n (CRC0n)

CRC0n is the register that controls the operation of CR00n and CR01n.

Changing the value of CRC0n is prohibited during operation (when TMC0n3 and TMC0n2 = other than 00).

CRC0n can be set by a 1-bit or 8-bit memory manipulation instruction.

Reset signal generation clears CRC0n to 00H.

Remark n = 0: μ PD78F0531, 78F0532, 78F0533
 n = 0, 1: μ PD78F0534, 78F0535, 78F0536, 78F0537, 78F0537D

Figure 7-8. Format of Capture/Compare Control Register 00 (CRC00)

Address: FFBC_H After reset: 00H R/W

Symbol	7	6	5	4	3	2	1	0
CRC00	0	0	0	0	0	CRC002	CRC001	CRC000

CRC002	CR010 operating mode selection
0	Operates as compare register
1	Operates as capture register

CRC001	CR000 capture trigger selection
0	Captures on valid edge of TI010 pin
1	Captures on valid edge of TI000 pin by reverse phase ^{Note}
The valid edge of the TI010 and TI000 pin is set by PRM00. If ES001 and ES000 are set to 11 (both edges) when CRC001 is 1, the valid edge of the TI000 pin cannot be detected.	

CRC000	CR000 operating mode selection
0	Operates as compare register
1	Operates as capture register
If TMC003 and TMC002 are set to 11 (clear & start mode entered upon a match between TM00 and CR000), be sure to set CRC000 to 0.	

Note When the valid edge is detected from the TI010 pin, the capture operation is not performed but the INTTM000 signal is generated as an external interrupt signal.

Caution To ensure that the capture operation is performed properly, the capture trigger requires a pulse two cycles longer than the count clock selected by prescaler mode register 00 (PRM00).

Figure 7-9. Example of CR01n Capture Operation (When Rising Edge Is Specified)

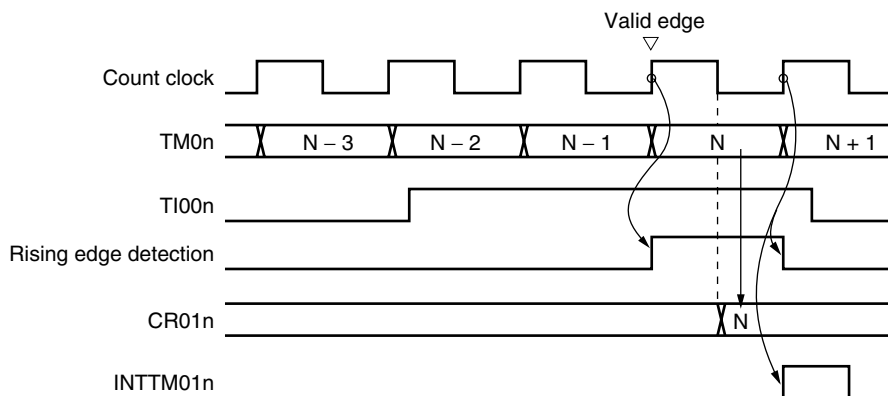

Remark n = 0: μ PD78F0531, 78F0532, 78F0533
 n = 0, 1: μ PD78F0534, 78F0535, 78F0536, 78F0537, 78F0537D

Figure 7-10. Format of Capture/Compare Control Register 01 (CRC01)

Address: FFB8H After reset: 00H R/W

Symbol	7	6	5	4	3	2	1	0
CRC01	0	0	0	0	0	CRC012	CRC011	CRC010

CRC012	CR011 operating mode selection
0	Operates as compare register
1	Operates as capture register

CRC011	CR001 capture trigger selection
0	Captures on valid edge of TI011 pin
1	Captures on valid edge of TI001 pin by reverse phase ^{Note}
The valid edge of the TI011 and TI001 pin is set by PRM01. If ES011 and ES010 are set to 11 (both edges) when CRC011 is 1, the valid edge of the TI001 pin cannot be detected.	

CRC010	CR001 operating mode selection
0	Operates as compare register
1	Operates as capture register
If TMC013 and TMC012 are set to 11 (clear & start mode entered upon a match between TM01 and CR001), be sure to set CRC010 to 0.	

Note When the valid edge is detected from the TI011 pin, the capture operation is not performed but the INTTM001 signal is generated as an external interrupt signal.

Caution To ensure that the capture operation is performed properly, the capture trigger requires a pulse two cycles longer than the count clock selected by prescaler mode register 01 (PRM01) (see Figure 7-9 Example of CR01n Capture Operation (When Rising Edge Is Specified)).

(3) 16-bit timer output control register 0n (TOC0n)

TOC0n is an 8-bit register that controls the TO0n pin output.

TOC0n can be rewritten while only OSPT0n is operating (when TMC0n3 and TMC0n2 = other than 00).
Rewriting the other bits is prohibited during operation.

However, TOC0n4 can be rewritten during timer operation as a means to rewrite CR01n (see **7.5.1 Rewriting CR01n during TM0n operation**).

TOC0n can be set by a 1-bit or 8-bit memory manipulation instruction.

Reset signal generation clears TOC0n to 00H.

Caution Be sure to set TOC0n using the following procedure.

<1> Set TOC0n4 and TOC0n1 to 1.

<2> Set only TOE0n to 1.

<3> Set either of LVS0n or LVR0n to 1.

Remark n = 0: μ PD78F0531, 78F0532, 78F0533

n = 0, 1: μ PD78F0534, 78F0535, 78F0536, 78F0537, 78F0537D

Figure 7-11. Format of 16-Bit Timer Output Control Register 00 (TOC00)

Address: FFBDAH After reset: 00H R/W

Symbol	7	<6>	<5>	4	<3>	<2>	1	<0>
TOC00	0	OSPT00	OSPE00	TOC004	LVS00	LVR00	TOC001	TOE00

OSPT00	One-shot pulse output trigger via software
0	–
1	One-shot pulse output
<p>The value of this bit is always “0” when it is read. Do not set this bit to 1 in a mode other than the one-shot pulse output mode. If it is set to 1, TM00 is cleared and started.</p>	

OSPE00	One-shot pulse output operation control
0	Successive pulse output
1	One-shot pulse output
<p>One-shot pulse output operates correctly in the free-running timer mode or clear & start mode entered by T1000 pin valid edge input. The one-shot pulse cannot be output in the clear & start mode entered upon a match between TM00 and CR000.</p>	

TOC004	TO00 pin output control on match between CR010 and TM00
0	Disables inversion operation
1	Enables inversion operation
<p>The interrupt signal (INTTM010) is generated even when TOC004 = 0.</p>	

LVS00	LVR00	Setting of TO00 pin output status
0	0	No change
0	1	Initial value of TO00 pin output is low level (TO00 pin output is cleared to 0).
1	0	Initial value of TO00 pin output is high level (TO00 pin output is set to 1).
1	1	Setting prohibited
<ul style="list-style-type: none"> LVS00 and LVR00 can be used to set the initial value of the output level of the TO00 pin. If the initial value does not have to be set, leave LVS00 and LVR00 as 00. Be sure to set LVS00 and LVR00 when TOE00 = 1. LVS00, LVR00, and TOE00 being simultaneously set to 1 is prohibited. LVS00 and LVR00 are trigger bits. By setting these bits to 1, the initial value of the output level of the TO00 pin can be set. Even if these bits are cleared to 0, output of the TO00 pin is not affected. The values of LVS00 and LVR00 are always 0 when they are read. For how to set LVS00 and LVR00, see 7.5.2 Setting LVS0n and LVR0n. 		

TOC001	TO00 pin output control on match between CR000 and TM00
0	Disables inversion operation
1	Enables inversion operation
<p>The interrupt signal (INTTM000) is generated even when TOC001 = 0.</p>	

TOE00	TO00 pin output control
0	Disables output (TO00 pin output fixed to low level)
1	Enables output

Figure 7-12. Format of 16-Bit Timer Output Control Register 01 (TOC01)

Address: FFB9H After reset: 00H R/W

Symbol	7	<6>	<5>	4	<3>	<2>	1	<0>
TOC01	0	OSPT01	OSPE01	TOC014	LVS01	LVR01	TOC011	TOE01
OSPT01	One-shot pulse output trigger via software							
0	-							
1	One-shot pulse output							
The value of this bit is always 0 when it is read. Do not set this bit to 1 in a mode other than the one-shot pulse output mode. If it is set to 1, TM01 is cleared and started.								
OSPE01	One-shot pulse output operation control							
0	Successive pulse output							
1	One-shot pulse output							
One-shot pulse output operates correctly in the free-running timer mode or clear & start mode entered by T1001 pin valid edge input. The one-shot pulse cannot be output in the clear & start mode entered upon a match between TM01 and CR001.								
TOC014	TO01 pin output control on match between CR011 and TM01							
0	Disables inversion operation							
1	Enables inversion operation							
The interrupt signal (INTTM01) is generated even when TOC014 = 0.								
LVS01	LVR01	Setting of TO01 pin output status						
0	0	No change						
0	1	Initial value of TO01 pin output is low level (TO01 pin output is cleared to 0).						
1	0	Initial value of TO01 pin output is high level (TO01 pin output is set to 1).						
1	1	Setting prohibited						
<ul style="list-style-type: none"> LVS01 and LVR01 can be used to set the initial value of the output level of the TO01 pin. If the initial value does not have to be set, leave LVS01 and LVR01 as 00. Be sure to set LVS01 and LVR01 when TOE01 = 1. LVS01, LVR01, and TOE01 being simultaneously set to 1 is prohibited. LVS01 and LVR01 are trigger bits. By setting these bits to 1, the initial value of the output level of the TO01 pin can be set. Even if these bits are cleared to 0, output of the TO01 pin is not affected. The values of LVS01 and LVR01 are always 0 when they are read. For how to set LVS01 and LVR01, see 7.5.2 Setting LVS0n and LVR0n. 								
TOC011	TO01 pin output control on match between CR001 and TM01							
0	Disables inversion operation							
1	Enables inversion operation							
The interrupt signal (INTTM001) is generated even when TOC011 = 0.								
TOE01	TO01 pin output control							
0	Disables output (TO01 pin output is fixed to low level)							
1	Enables output							

(4) Prescaler mode register 0n (PRM0n)

PRM0n is the register that sets the TM0n count clock and TI00n and TI01n pin input valid edges.

Rewriting PRM0n is prohibited during operation (when TMC0n3 and TMC0n2 = other than 00).

PRM0n can be set by a 1-bit or 8-bit memory manipulation instruction.

Reset signal generation sets PRM0n to 00H.

Cautions 1. Do not apply the following setting when setting the PRM0n1 and PRM0n0 bits to 11 (to specify the valid edge of the TI00n pin as a count clock).

- Clear & start mode entered by the TI00n pin valid edge
- Setting the TI00n pin as a capture trigger

2. If the operation of the 16-bit timer/event counter 0n is enabled when the TI00n or TI01n pin is at high level and when the valid edge of the TI00n or TI01n pin is specified to be the rising edge or both edges, the high level of the TI00n or TI01n pin is detected as a rising edge. Note this when the TI00n or TI01n pin is pulled up. However, the rising edge is not detected when the timer operation has been once stopped and then is enabled again.

3. The valid edge of TI010 and timer output (TO00) cannot be used for the P01 pin at the same time, and the valid edge of TI011 and timer output (TO01) cannot be used for the P06 pin at the same time. Select either of the functions.

Remark n = 0: μ PD78F0531, 78F0532, 78F0533

n = 0, 1: μ PD78F0534, 78F0535, 78F0536, 78F0537, 78F0537D

Figure 7-13. Format of Prescaler Mode Register 00 (PRM00)

Address: FFBBH After reset: 00H R/W

Symbol	7	6	5	4	3	2	1	0
PRM00	ES101	ES100	ES001	ES000	0	0	PRM001	PRM000

ES101	ES100	TI010 pin valid edge selection
0	0	Falling edge
0	1	Rising edge
1	0	Setting prohibited
1	1	Both falling and rising edges

ES001	ES000	TI000 pin valid edge selection
0	0	Falling edge
0	1	Rising edge
1	0	Setting prohibited
1	1	Both falling and rising edges

PRM001	PRM000	Count clock selection				
		f_{PRS}	$f_{PRS} = 2 \text{ MHz}$	$f_{PRS} = 5 \text{ MHz}$	$f_{PRS} = 10 \text{ MHz}$	$f_{PRS} = 20 \text{ MHz}$
0	0	f_{PRS}	2 MHz	5 MHz	10 MHz	20 MHz
0	1	$f_{PRS}/2^2$	500 kHz	1.25 MHz	2.5 MHz	5 MHz
1	0	$f_{PRS}/2^8$	7.81 kHz	19.53 kHz	39.06 kHz	78.12 kHz
1	1	TI000 valid edge ^{Note}				

Note The external clock requires a pulse two cycles longer than internal clock (f_{PRS}).

Remark f_{PRS} : Peripheral hardware clock frequency

Figure 7-14. Format of Prescaler Mode Register 01 (PRM01)

Address: FFB7H After reset: 00H R/W

Symbol	7	6	5	4	3	2	1	0
PRM01	ES111	ES110	ES011	ES010	0	0	PRM011	PRM010

ES111	ES110	TI011 pin valid edge selection
0	0	Falling edge
0	1	Rising edge
1	0	Setting prohibited
1	1	Both falling and rising edges

ES011	ES010	TI001 pin valid edge selection
0	0	Falling edge
0	1	Rising edge
1	0	Setting prohibited
1	1	Both falling and rising edges

PRM011	PRM010	Count clock selection				
		$f_{PRS} = 2 \text{ MHz}$	$f_{PRS} = 5 \text{ MHz}$	$f_{PRS} = 10 \text{ MHz}$	$f_{PRS} = 20 \text{ MHz}$	
0	0	f_{PRS}	2 MHz	5 MHz	10 MHz	20 MHz
0	1	$f_{PRS}/2^4$	125 kHz	312.5 kHz	625 kHz	1.25 MHz
1	0	$f_{PRS}/2^6$	31.25 kHz	78.125 kHz	156.25 kHz	312.5 kHz
1	1	TI001 valid edge ^{Note}				

Note The external clock requires a pulse two cycles longer than internal clock (f_{PRS}).

Remark f_{PRS} : Peripheral hardware clock frequency

(5) Port mode register 0 (PM0)

This register sets port 0 input/output in 1-bit units.

When using the P01/TO00/TI010 and P06/TO01/TI011 pins for timer output, set PM01 and PM06 and the output latches of P01 and P06 to 0.

When using the P00/TI000, P01/TO00/TI010, P05/TI001/ $\overline{\text{SSI}}11$, and P06/TO01/TI011 pins for timer input, set PM00, PM01, PM05, and PM06 to 1. At this time, the output latches of P00, P01, P05, and P06 may be 0 or 1.

PM0 can be set by a 1-bit or 8-bit memory manipulation instruction.

Reset signal generation sets PM0 to FFH.

Figure 7-15. Format of Port Mode Register 0 (PM0)

Address: FF20H After reset: FFH R/W

Symbol	7	6	5	4	3	2	1	0
PM0	1	PM06	PM05	PM04	PM03	PM02	PM01	PM00

PM0n	P0n pin I/O mode selection (n = 0 to 6)
0	Output mode (output buffer on)
1	Input mode (output buffer off)

7.4 Operation of 16-Bit Timer/Event Counters 00 and 01

7.4.1 Interval timer operation

If bits 3 and 2 (TMC0n3 and TMC0n2) of the 16-bit timer mode control register (TMC0n) are set to 11 (clear & start mode entered upon a match between TM0n and CR00n), the count operation is started in synchronization with the count clock.

When the value of TM0n later matches the value of CR00n, TM0n is cleared to 0000H and a match interrupt signal (INTTM00n) is generated. This INTTM00n signal enables TM0n to operate as an interval timer.

- Remarks**
1. For the setting of I/O pins, see 7.3 (5) **Port mode register 0 (PM0)**.
 2. For how to enable the INTTM00n interrupt, see **CHAPTER 19 INTERRUPT FUNCTIONS**.

Figure 7-16. Block Diagram of Interval Timer Operation

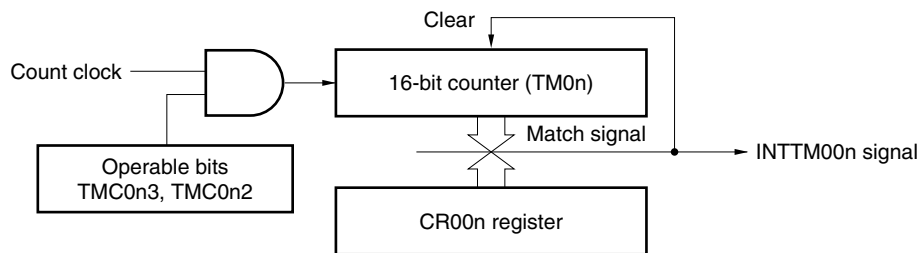
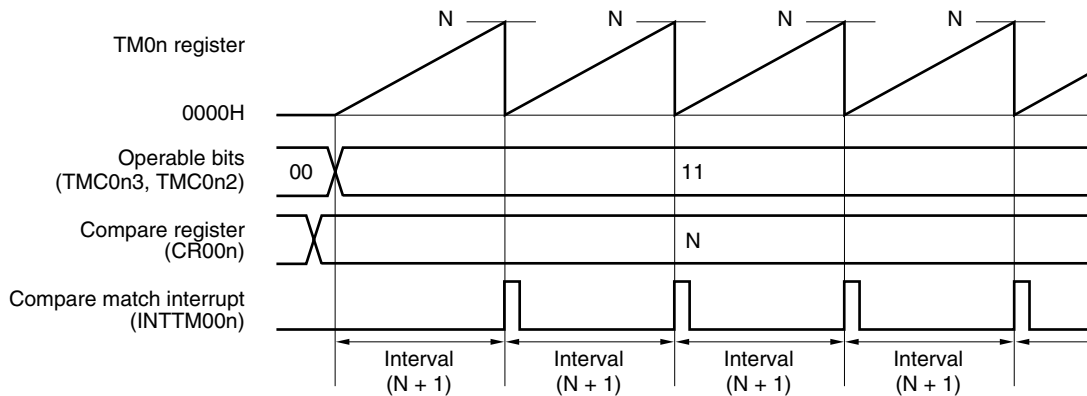
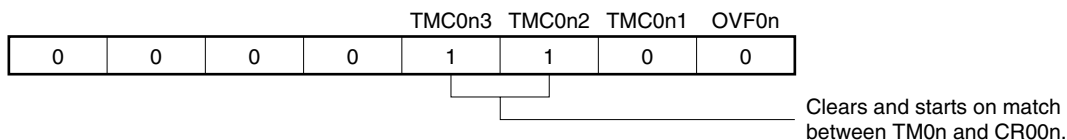
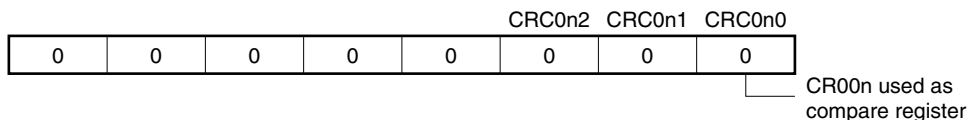
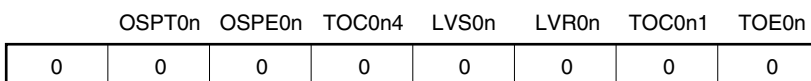
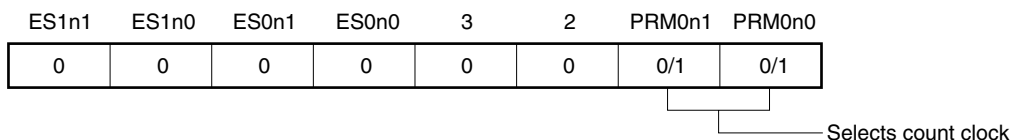

Figure 7-17. Basic Timing Example of Interval Timer Operation



- Remark**
- n = 0: μ PD78F0531, 78F0532, 78F0533
 - n = 0, 1: μ PD78F0534, 78F0535, 78F0536, 78F0537, 78F0537D

Figure 7-18. Example of Register Settings for Interval Timer Operation

(a) 16-bit timer mode control register 0n (TMC0n)**(b) Capture/compare control register 0n (CRC0n)****(c) 16-bit timer output control register 0n (TOC0n)****(d) Prescaler mode register 0n (PRM0n)****(e) 16-bit timer counter 0n (TM0n)**

By reading TM0n, the count value can be read.

(f) 16-bit capture/compare register 00n (CR00n)

If M is set to CR00n, the interval time is as follows.

- Interval time = (M + 1) × Count clock cycle

Setting CR00n to 0000H is prohibited.

(g) 16-bit capture/compare register 01n (CR01n)

Usually, CR01n is not used for the interval timer function. However, a compare match interrupt (INTTM01n) is generated when the set value of CR01n matches the value of TM0n.

Therefore, mask the interrupt request by using the interrupt mask flag (TMMK01n).

Remark n = 0: μ PD78F0531, 78F0532, 78F0533
 n = 0, 1: μ PD78F0534, 78F0535, 78F0536, 78F0537, 78F0537D

Figure 7-19. Example of Software Processing for Interval Timer Function

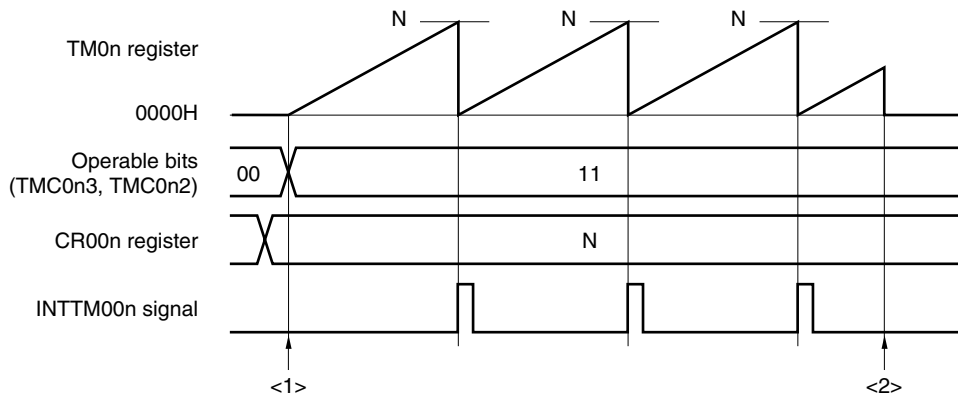

<1> Count operation start flow

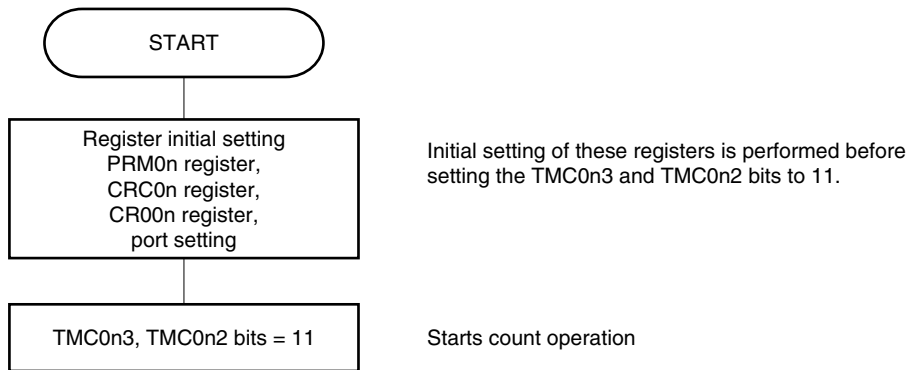

<2> Count operation stop flow

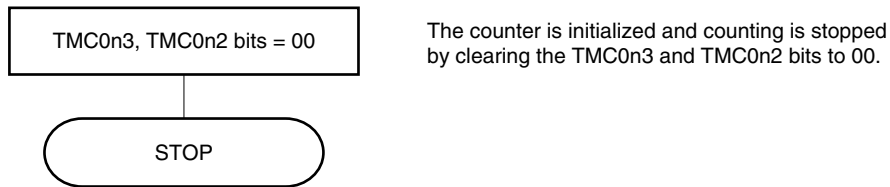

Remark n = 0: μ PD78F0531, 78F0532, 78F0533
 n = 0, 1: μ PD78F0534, 78F0535, 78F0536, 78F0537, 78F0537D

7.4.2 Square wave output operation

When 16-bit timer/event counter 0n operates as an interval timer (see 7.4.1), a square wave can be output from the TO0n pin by setting the 16-bit timer output control register 0n (TOC0n) to 03H.

When TMC0n3 and TMC0n2 are set to 11 (count clear & start mode entered upon a match between TM0n and CR00n), the counting operation is started in synchronization with the count clock.

When the value of TM0n later matches the value of CR00n, TM0n is cleared to 0000H, an interrupt signal (INTTM00n) is generated, and output of the TO0n pin is inverted. This TO0n pin output that is inverted at fixed intervals enables TO0n to output a square wave.

- Remarks**
1. For the setting of I/O pins, see 7.3 (5) **Port mode register 0 (PM0)**.
 2. For how to enable the INTTM00n signal interrupt, see **CHAPTER 19 INTERRUPT FUNCTIONS**.

Figure 7-20. Block Diagram of Square Wave Output Operation

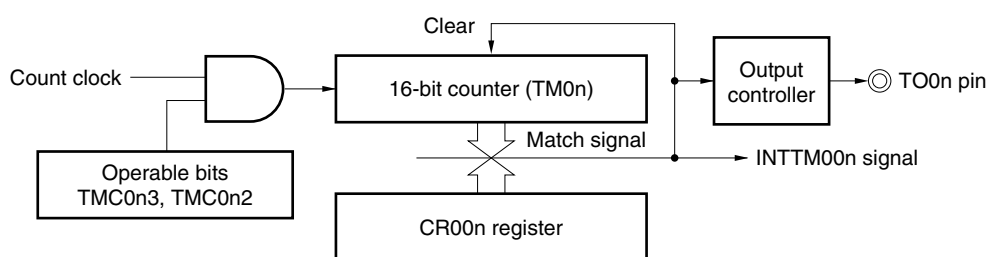

- Remark**
- n = 0: μ PD78F0531, 78F0532, 78F0533
n = 0, 1: μ PD78F0534, 78F0535, 78F0536, 78F0537, 78F0537D

Figure 7-21. Basic Timing Example of Square Wave Output Operation

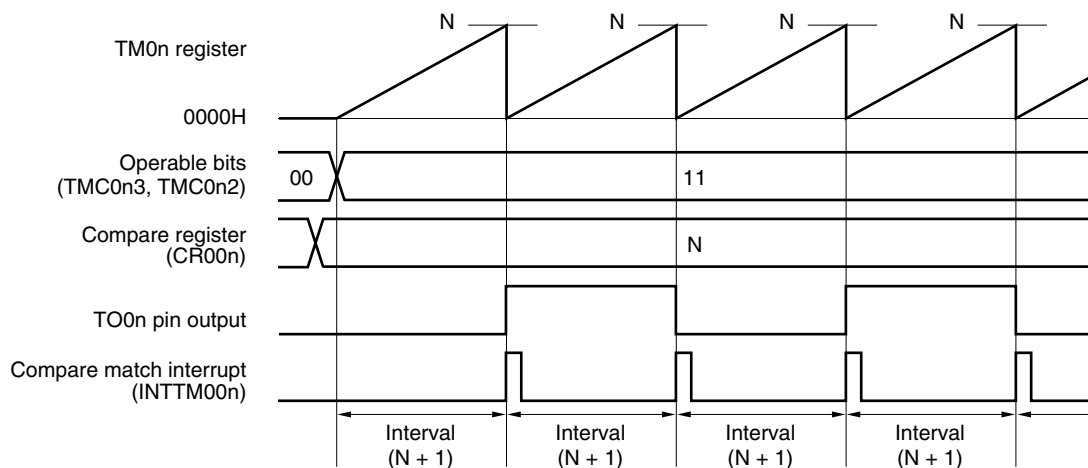

- Remark**
- n = 0: μ PD78F0531, 78F0532, 78F0533
n = 0, 1: μ PD78F0534, 78F0535, 78F0536, 78F0537, 78F0537D

Figure 7-23. Example of Software Processing for Square Wave Output Function

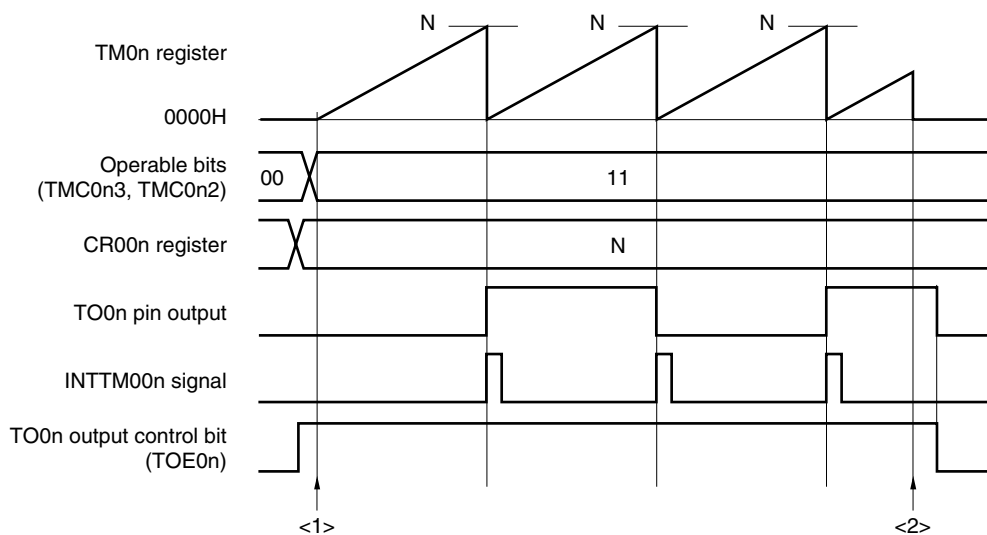

<1> Count operation start flow

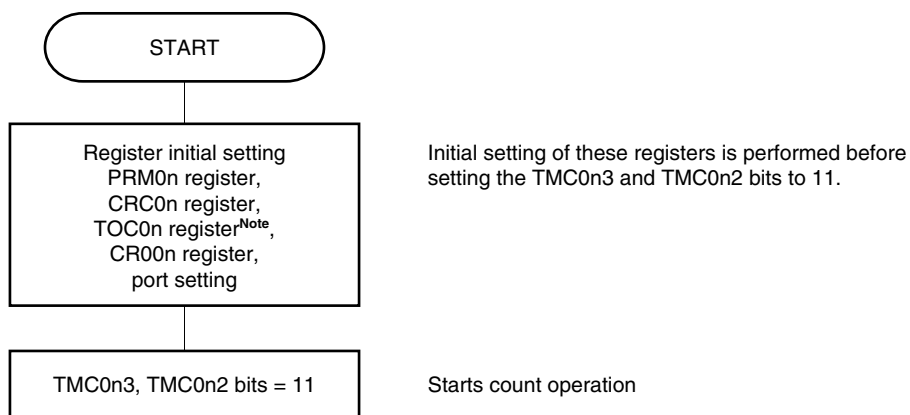

<2> Count operation stop flow

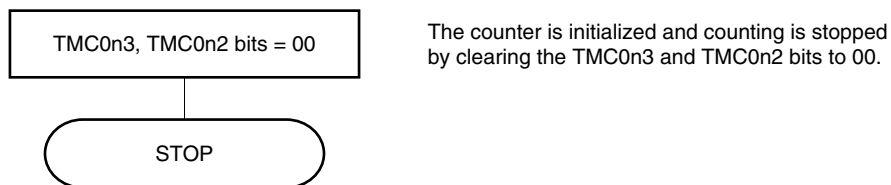

Note Care must be exercised when setting TOC0n. For details, see 7.3 (3) 16-bit timer output control register 0n (TOC0n).

Remark n = 0: μ PD78F0531, 78F0532, 78F0533
 n = 0, 1: μ PD78F0534, 78F0535, 78F0536, 78F0537, 78F0537D

7.4.3 External event counter operation

When bits 1 and 0 (PRM0n1 and PRM0n0) of the prescaler mode register 0n (PRM0n) are set to 11 (for counting up with the valid edge of the TI00n pin) and bits 3 and 2 (TMC0n3 and TMC0n2) of 16-bit timer mode control register 0n (TMC0n) are set to 11, the valid edge of an external event input is counted, and a match interrupt signal indicating matching between TM0n and CR00n (INTTM00n) is generated.

To input the external event, the TI00n pin is used. Therefore, the timer/event counter cannot be used as an external event counter in the clear & start mode entered by the TI00n pin valid edge input (when TMC0n3 and TMC0n2 = 10).

The INTTM00n signal is generated with the following timing.

- Timing of generation of INTTM00n signal (second time or later)
= Number of times of detection of valid edge of external event \times (Set value of CR00n + 1)

However, the first match interrupt immediately after the timer/event counter has started operating is generated with the following timing.

- Timing of generation of INTTM00n signal (first time only)
= Number of times of detection of valid edge of external event input \times (Set value of CR00n + 2)

To detect the valid edge, the signal input to the TI00n pin is sampled during the clock cycle of fPRS. The valid edge is not detected until it is detected two times in a row. Therefore, a noise with a short pulse width can be eliminated.

Remarks 1. For the setting of I/O pins, see 7.3 (5) **Port mode register 0 (PM0)**.

2. For how to enable the INTTM00n signal interrupt, see **CHAPTER 19 INTERRUPT FUNCTIONS**.

Figure 7-24. Block Diagram of External Event Counter Operation

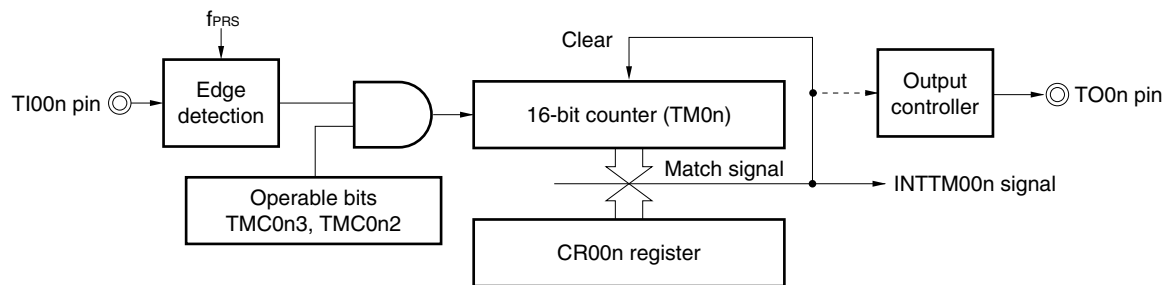

Remark n = 0: μ PD78F0531, 78F0532, 78F0533
n = 0, 1: μ PD78F0534, 78F0535, 78F0536, 78F0537, 78F0537D

Figure 7-25. Example of Register Settings in External Event Counter Mode

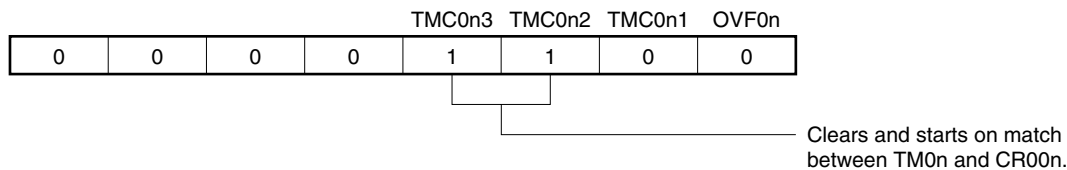
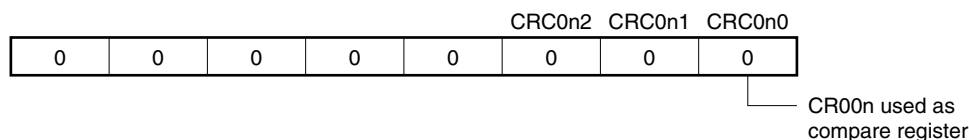
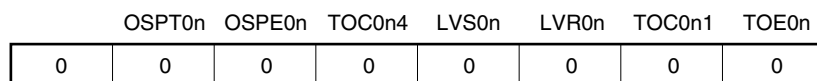
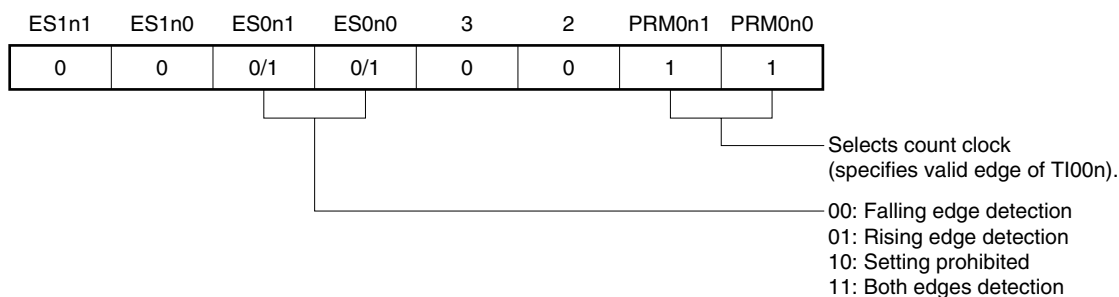
(a) 16-bit timer mode control register 0n (TMC0n)**(b) Capture/compare control register 0n (CRC0n)****(c) 16-bit timer output control register 0n (TOC0n)****(d) Prescaler mode register 0n (PRM0n)****(e) 16-bit timer counter 0n (TM0n)**

By reading TM0n, the count value can be read.

(f) 16-bit capture/compare register 00n (CR00n)

If M is set to CR00n, the interrupt signal (INTTM00n) is generated when the number of external events reaches (M + 1).

Setting CR00n to 0000H is prohibited.

(g) 16-bit capture/compare register 01n (CR01n)

Usually, CR01n is not used in the external event counter mode. However, a compare match interrupt (INTTM01n) is generated when the set value of CR01n matches the value of TM0n.

Therefore, mask the interrupt request by using the interrupt mask flag (TMMK01n).

Remark n = 0: μ PD78F0531, 78F0532, 78F0533

n = 0, 1: μ PD78F0534, 78F0535, 78F0536, 78F0537, 78F0537D

Figure 7-26. Example of Software Processing in External Event Counter Mode

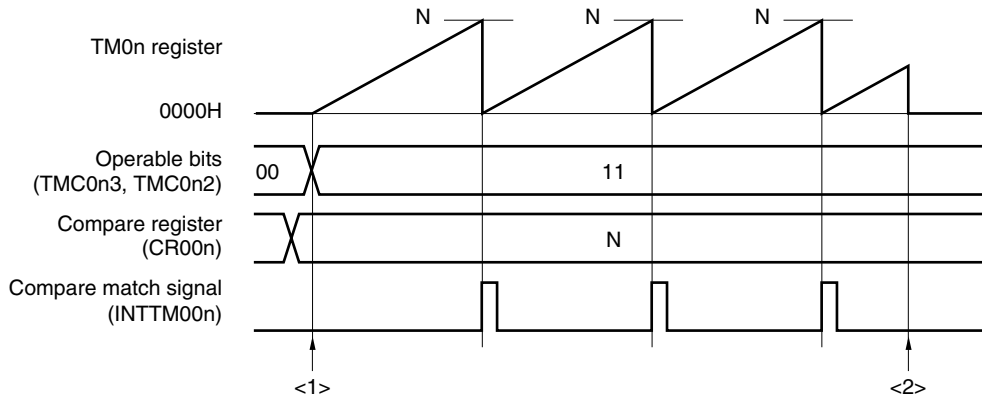

<1> Count operation start flow

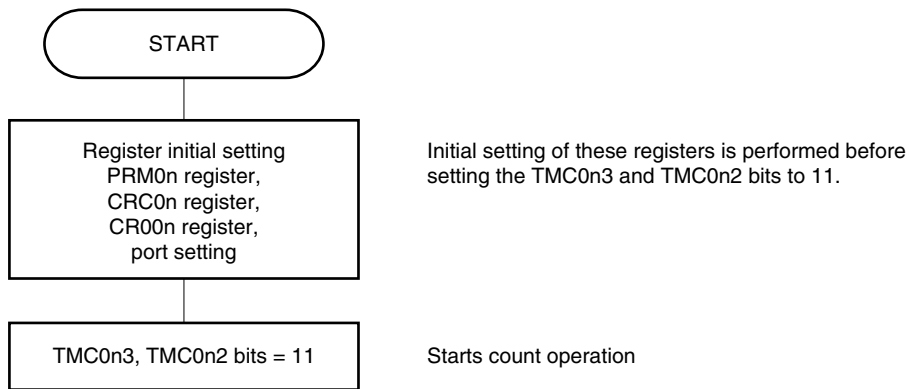

<2> Count operation stop flow

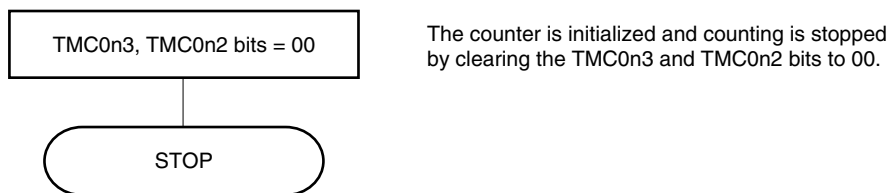

Remark n = 0: μ PD78F0531, 78F0532, 78F0533
 n = 0, 1: μ PD78F0534, 78F0535, 78F0536, 78F0537, 78F0537D

7.4.4 Operation in clear & start mode entered by TI00n pin valid edge input

When bits 3 and 2 (TMC0n3 and TMC0n2) of 16-bit timer mode control register 0n (TMC0n) are set to 10 (clear & start mode entered by the TI00n pin valid edge input) and the count clock (set by PRM0n) is supplied to the timer/event counter, TM0n starts counting up. When the valid edge of the TI00n pin is detected during the counting operation, TM0n is cleared to 0000H and starts counting up again. If the valid edge of the TI00n pin is not detected, TM0n overflows and continues counting.

The valid edge of the TI00n pin is a cause to clear TM0n. Starting the counter is not controlled immediately after the start of the operation.

CR00n and CR01n are used as compare registers and capture registers.

(a) When CR00n and CR01n are used as compare registers

Signals INTTM00n and INTTM01n are generated when the value of TM0n matches the value of CR00n and CR01n.

(b) When CR00n and CR01n are used as capture registers

The count value of TM0n is captured to CR00n and the INTTM00n signal is generated when the valid edge is input to the TI01n pin (or when the phase reverse to that of the valid edge is input to the TI00n pin).

When the valid edge is input to the TI00n pin, the count value of TM0n is captured to CR01n and the INTTM01n signal is generated. As soon as the count value has been captured, the counter is cleared to 0000H.

Caution Do not set the count clock as the valid edge of the TI00n pin (PRM0n1 and PRM0n0 = 11). When PRM0n1 and PRM0n0 = 11, TM0n is cleared.

Remarks 1. For the setting of the I/O pins, see 7.3 (5) Port mode register 0 (PM0).

2. For how to enable the INTTM00n signal interrupt, see CHAPTER 19 INTERRUPT FUNCTIONS.

3. n = 0: μ PD78F0531, 78F0532, 78F0533

n = 0, 1: μ PD78F0534, 78F0535, 78F0536, 78F0537, 78F0537D

(1) Operation in clear & start mode entered by TI00n pin valid edge input
(CR00n: compare register, CR01n: compare register)

Figure 7-27. Block Diagram of Clear & Start Mode Entered by TI00n Pin Valid Edge Input
(CR00n: Compare Register, CR01n: Compare Register)

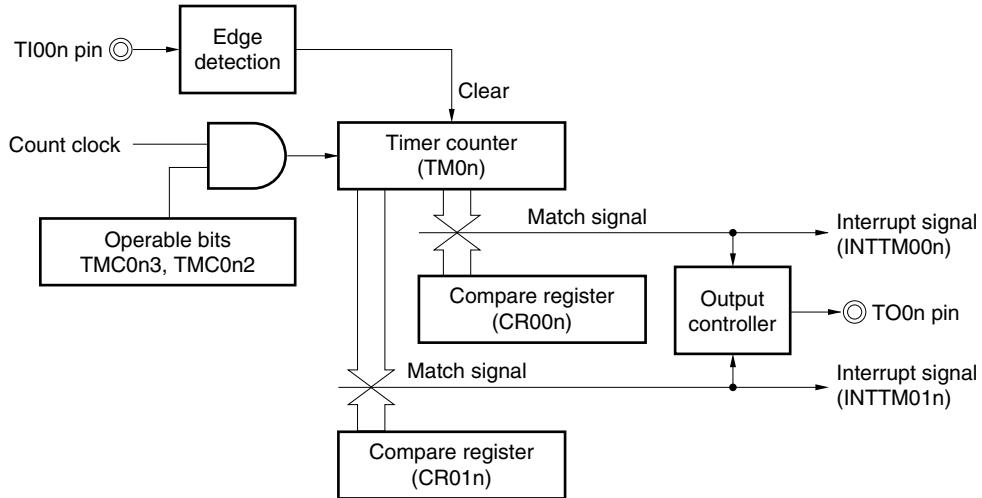

Remark n = 0: μ PD78F0531, 78F0532, 78F0533
n = 0, 1: μ PD78F0534, 78F0535, 78F0536, 78F0537, 78F0537D

Figure 7-28. Timing Example of Clear & Start Mode Entered by TI00n Pin Valid Edge Input (CR00n: Compare Register, CR01n: Compare Register)

(a) TOC0n = 13H, PRM0n = 10H, CRC0n, = 00H, TMC0n = 08H

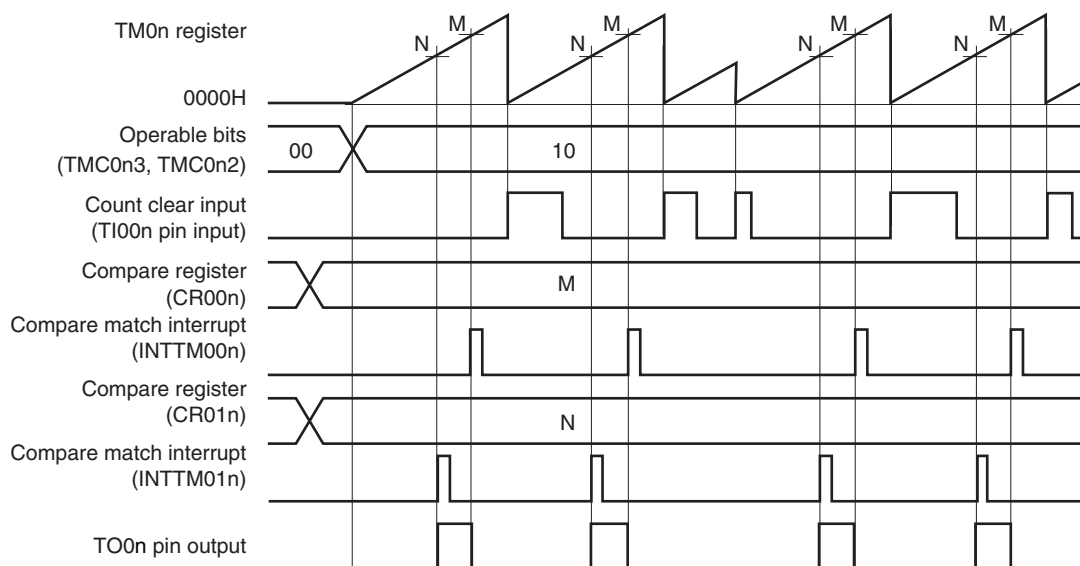

(b) TOC0n = 13H, PRM0n = 10H, CRC0n, = 00H, TMC0n = 0AH

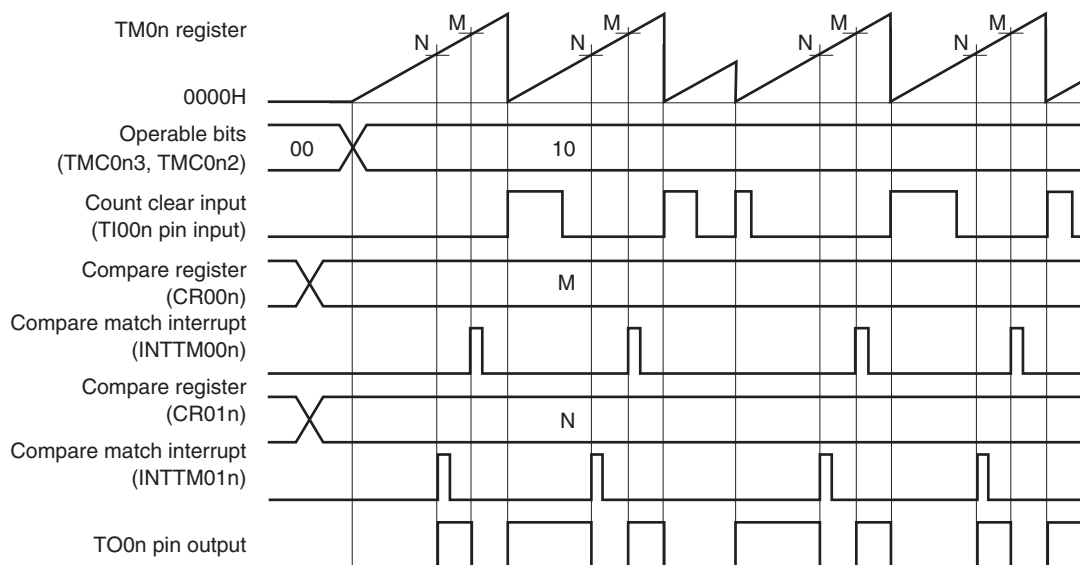

(a) and (b) differ as follows depending on the setting of bit 1 (TMC0n1) of the 16-bit timer mode control register 0n (TMC0n).

- (a) The output level of the TO0n pin is inverted when TM0n matches a compare register.
- (b) The output level of the TO0n pin is inverted when TM0n matches a compare register or when the valid edge of the TI00n pin is detected.

Remark n = 0: μ PD78F0531, 78F0532, 78F0533
 n = 0, 1: μ PD78F0534, 78F0535, 78F0536, 78F0537, 78F0537D

(2) Operation in clear & start mode entered by TI00n pin valid edge input
(CR00n: compare register, CR01n: capture register)

Figure 7-29. Block Diagram of Clear & Start Mode Entered by TI00n Pin Valid Edge Input
(CR00n: Compare Register, CR01n: Capture Register)

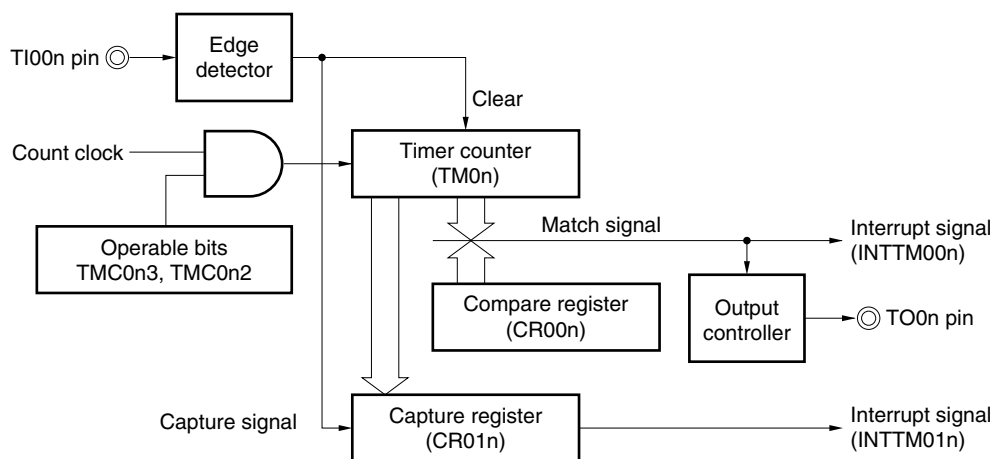

Remark n = 0: μ PD78F0531, 78F0532, 78F0533
n = 0, 1: μ PD78F0534, 78F0535, 78F0536, 78F0537, 78F0537D

Figure 7-30. Timing Example of Clear & Start Mode Entered by TI00n Pin Valid Edge Input (CR00n: Compare Register, CR01n: Capture Register) (1/2)

(a) TOC0n = 13H, PRM0n = 10H, CRC0n, = 04H, TMC0n = 08H, CR00n = 0001H

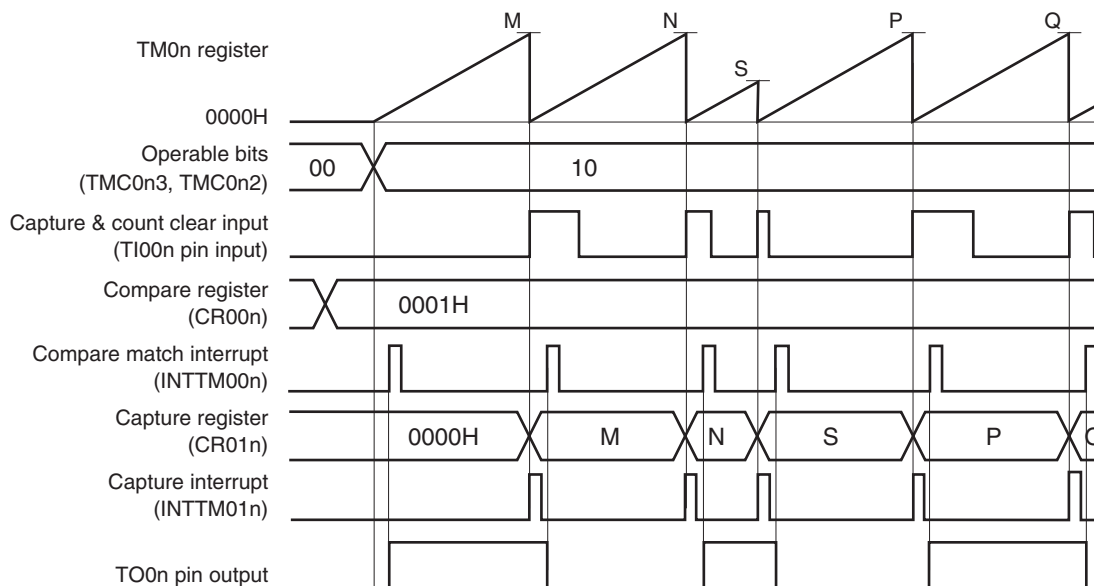

This is an application example where the output level of the TO0n pin is inverted when the count value has been captured & cleared.

The count value is captured to CR01n and TM0n is cleared (to 0000H) when the valid edge of the TI00n pin is detected. When the count value of TM0n is 0001H, a compare match interrupt signal (INTTM00n) is generated, and the output level of the TO0n pin is inverted.

Remark n = 0: μ PD78F0531, 78F0532, 78F0533
n = 0, 1: μ PD78F0534, 78F0535, 78F0536, 78F0537, 78F0537D

Figure 7-30. Timing Example of Clear & Start Mode Entered by TI00n Pin Valid Edge Input (CR00n: Compare Register, CR01n: Capture Register) (2/2)

(b) TOC0n = 13H, PRM0n = 10H, CRC0n = 04H, TMC0n = 0AH, CR00n = 0003H

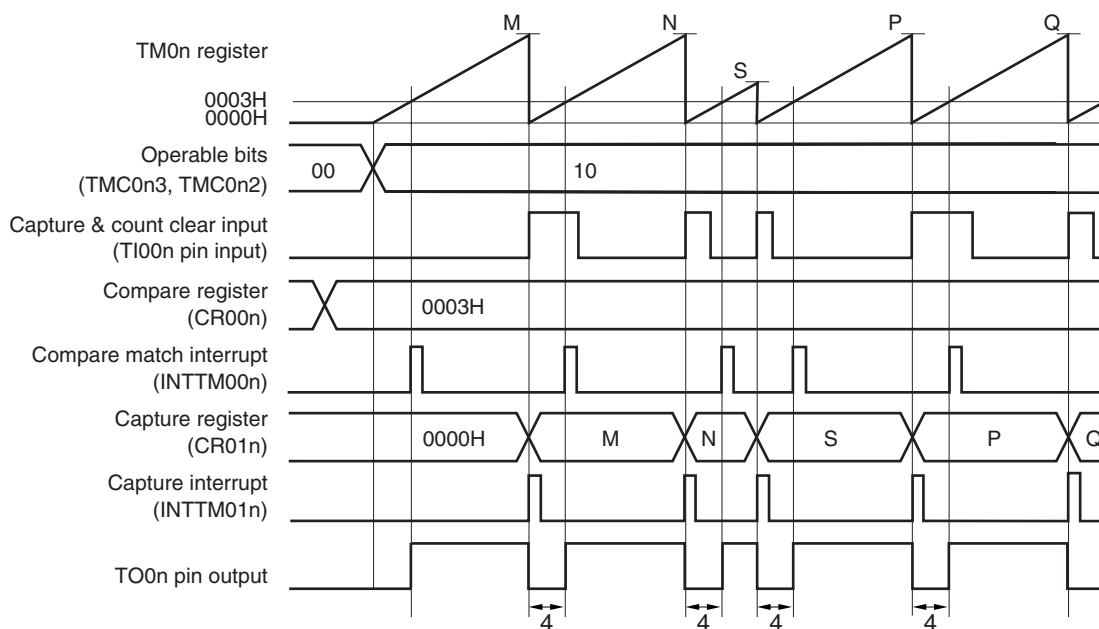

This is an application example where the width set to CR00n (4 clocks in this example) is to be output from the TO0n pin when the count value has been captured & cleared.

The count value is captured to CR01n, a capture interrupt signal (INTTM01n) is generated, TM0n is cleared (to 0000H), and the output level of the TO0n pin is inverted when the valid edge of the TI00n pin is detected. When the count value of TM0n is 0003H (four clocks have been counted), a compare match interrupt signal (INTTM00n) is generated and the output level of the TO0n pin is inverted.

Remark n = 0: μ PD78F0531, 78F0532, 78F0533

n = 0, 1: μ PD78F0534, 78F0535, 78F0536, 78F0537, 78F0537D

(3) Operation in clear & start mode by entered T100n pin valid edge input
(CR00n: capture register, CR01n: compare register)

Figure 7-31. Block Diagram of Clear & Start Mode Entered by T100n Pin Valid Edge Input
(CR00n: Capture Register, CR01n: Compare Register)

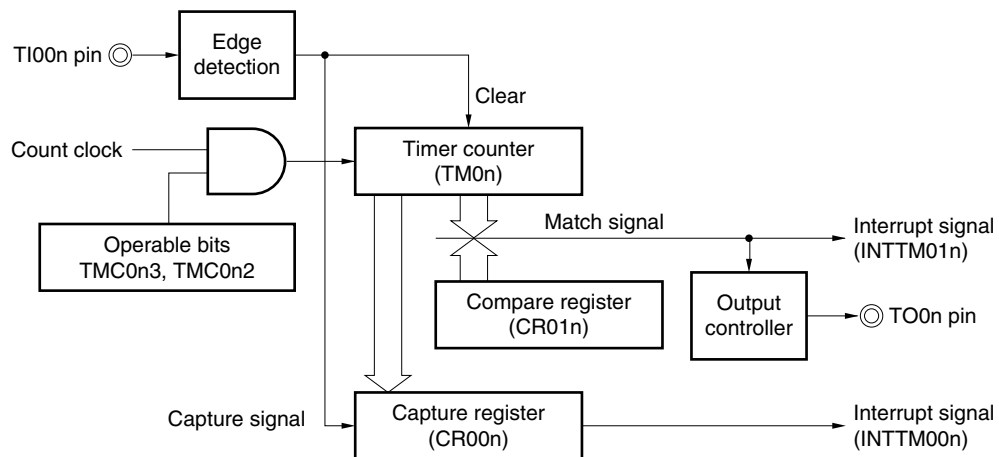

Remark n = 0: μ PD78F0531, 78F0532, 78F0533
n = 0, 1: μ PD78F0534, 78F0535, 78F0536, 78F0537, 78F0537D

Figure 7-32. Timing Example of Clear & Start Mode Entered by TI00n Pin Valid Edge Input (CR00n: Capture Register, CR01n: Compare Register) (1/2)

(a) TOC0n = 13H, PRM0n = 10H, CRC0n = 03H, TMC0n = 08H, CR01n = 0001H

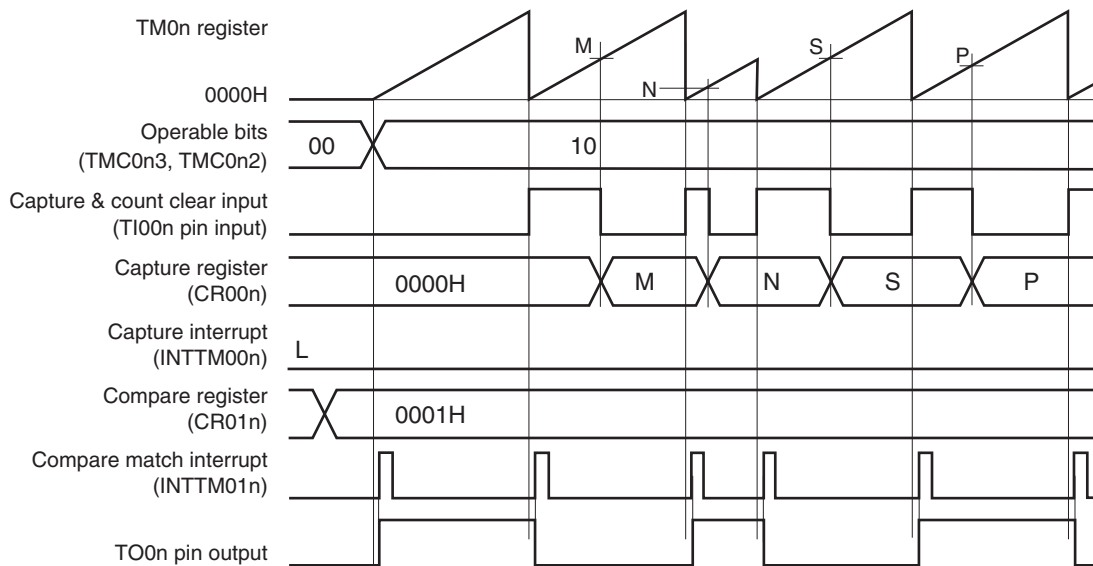

This is an application example where the output level of the TO0n pin is to be inverted when the count value has been captured & cleared.

TM0n is cleared at the rising edge detection of the TI00n pin and it is captured to CR00n at the falling edge detection of the TI00n pin.

When bit 1 (CRC0n1) of capture/compare control register 0n (CRC0n) is set to 1, the count value of TM0n is captured to CR00n in the phase reverse to that of the signal input to the TI00n pin, but the capture interrupt signal (INTTM00n) is not generated. However, the INTTM00n signal is generated when the valid edge of the TI01n pin is detected. Mask the INTTM00n signal when it is not used.

Remark n = 0: μ PD78F0531, 78F0532, 78F0533

n = 0, 1: μ PD78F0534, 78F0535, 78F0536, 78F0537, 78F0537D

Figure 7-32. Timing Example of Clear & Start Mode Entered by TI00n Pin Valid Edge Input (CR00n: Capture Register, CR01n: Compare Register) (2/2)

(b) TOC0n = 13H, PRM0n = 10H, CRC0n = 03H, TMC0n = 0AH, CR01n = 0003H

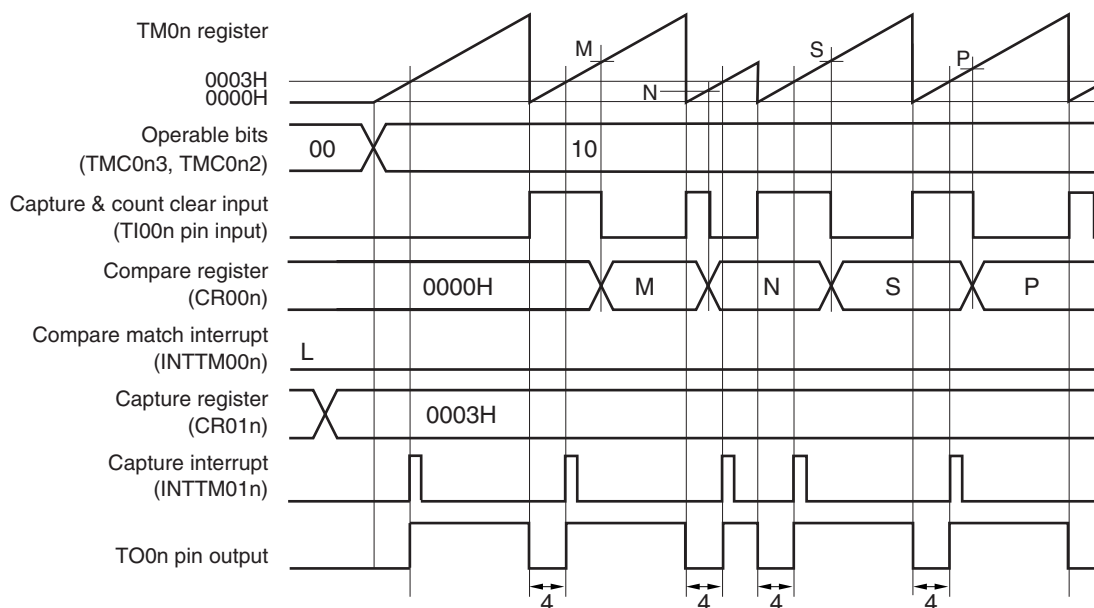

This is an application example where the width set to CR01n (4 clocks in this example) is to be output from the TO0n pin when the count value has been captured & cleared.

TM0n is cleared (to 0000H) at the rising edge detection of the TI00n pin and captured to CR00n at the falling edge detection of the TI00n pin. The output level of the TO0n pin is inverted when TM0n is cleared (to 0000H) because the rising edge of the TI00n pin has been detected or when the value of TM0n matches that of a compare register (CR01n).

When bit 1 (CRC0n1) of capture/compare control register 0n (CRC0n) is 1, the count value of TM0n is captured to CR00n in the phase reverse to that of the input signal of the TI00n pin, but the capture interrupt signal (INTTM00n) is not generated. However, the INTTM00n interrupt is generated when the valid edge of the TI01n pin is detected. Mask the INTTM00n signal when it is not used.

Remark n = 0: μ PD78F0531, 78F0532, 78F0533

n = 0, 1: μ PD78F0534, 78F0535, 78F0536, 78F0537, 78F0537D

(4) Operation in clear & start mode entered by TI00n pin valid edge input
(CR00n: capture register, CR01n: capture register)

Figure 7-33. Block Diagram of Clear & Start Mode Entered by TI00n Pin Valid Edge Input
(CR00n: Capture Register, CR01n: Capture Register)

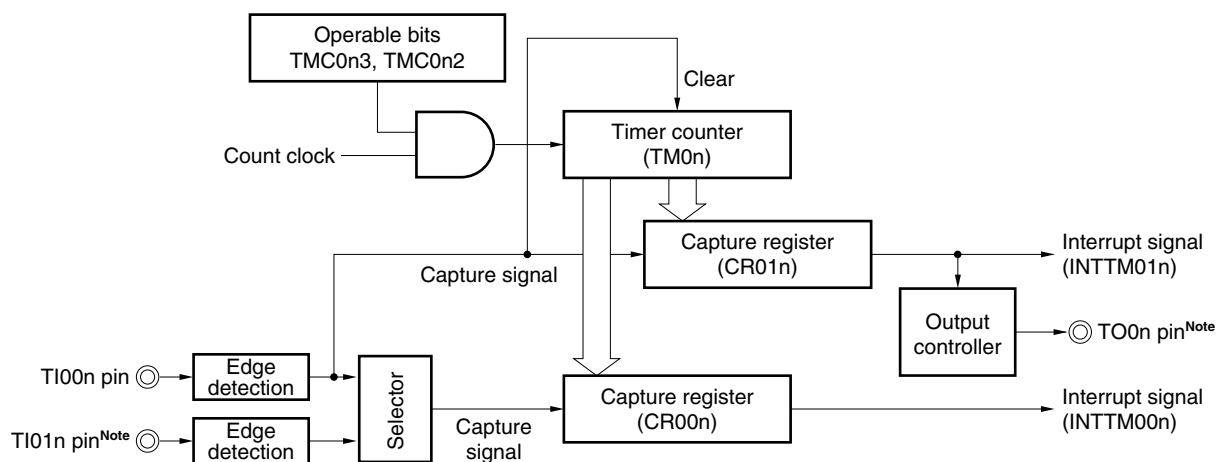

Note The timer output (TO0n) cannot be used when detecting the valid edge of the TI01n pin is used.

Remark n = 0: μ PD78F0531, 78F0532, 78F0533
n = 0, 1: μ PD78F0534, 78F0535, 78F0536, 78F0537, 78F0537D

Figure 7-34. Timing Example of Clear & Start Mode Entered by TI00n Pin Valid Edge Input (CR00n: Capture Register, CR01n: Capture Register) (1/3)

(a) TOC0n = 13H, PRM0n = 30H, CRC0n = 05H, TMC0n = 0AH

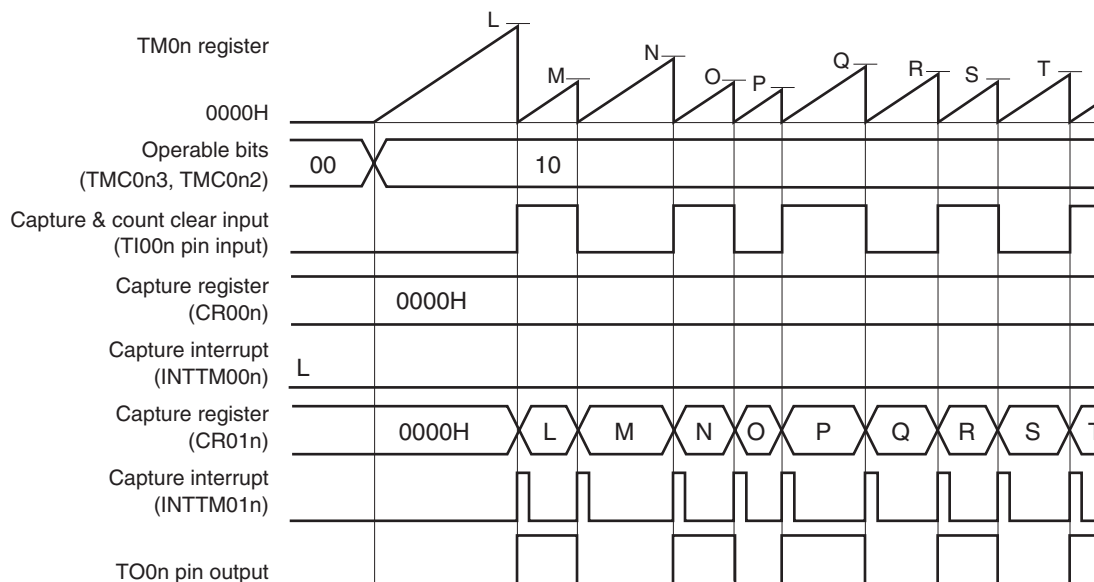

This is an application example where the count value is captured to CR01n, TM0n is cleared, and the TO0n pin output is inverted when the rising or falling edge of the TI00n pin is detected.

When the edge of the TI01n pin is detected, an interrupt signal (INTTM00n) is generated. Mask the INTTM00n signal when it is not used.

Remark n = 0: μ PD78F0531, 78F0532, 78F0533

n = 0, 1: μ PD78F0534, 78F0535, 78F0536, 78F0537, 78F0537D

Figure 7-34. Timing Example of Clear & Start Mode Entered by TI00n Pin Valid Edge Input (CR00n: Capture Register, CR01n: Capture Register) (2/3)

(b) TOC0n = 13H, PRM0n = C0H, CRC0n = 05H, TMC0n = 0AH

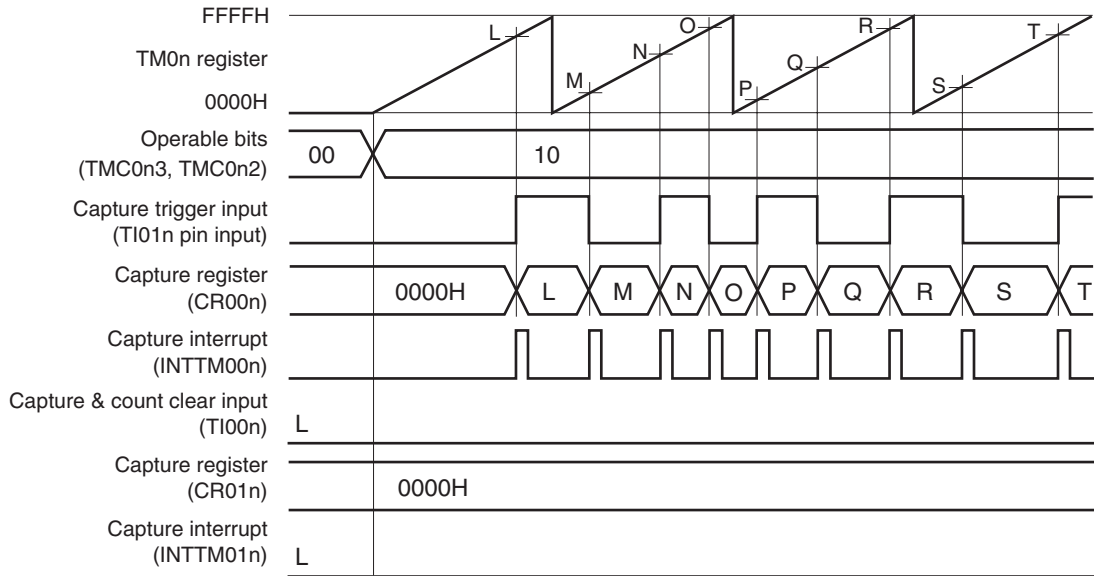

This is a timing example where an edge is not input to the TI00n pin, in an application where the count value is captured to CR00n when the rising or falling edge of the TI01n pin is detected.

Remark n = 0: μ PD78F0531, 78F0532, 78F0533
 n = 0, 1: μ PD78F0534, 78F0535, 78F0536, 78F0537, 78F0537D

Figure 7-34. Timing Example of Clear & Start Mode Entered by TI00n Pin Valid Edge Input (CR00n: Capture Register, CR01n: Capture Register) (3/3)

(c) TOC0n = 13H, PRM0n = 00H, CRC0n = 07H, TMC0n = 0AH

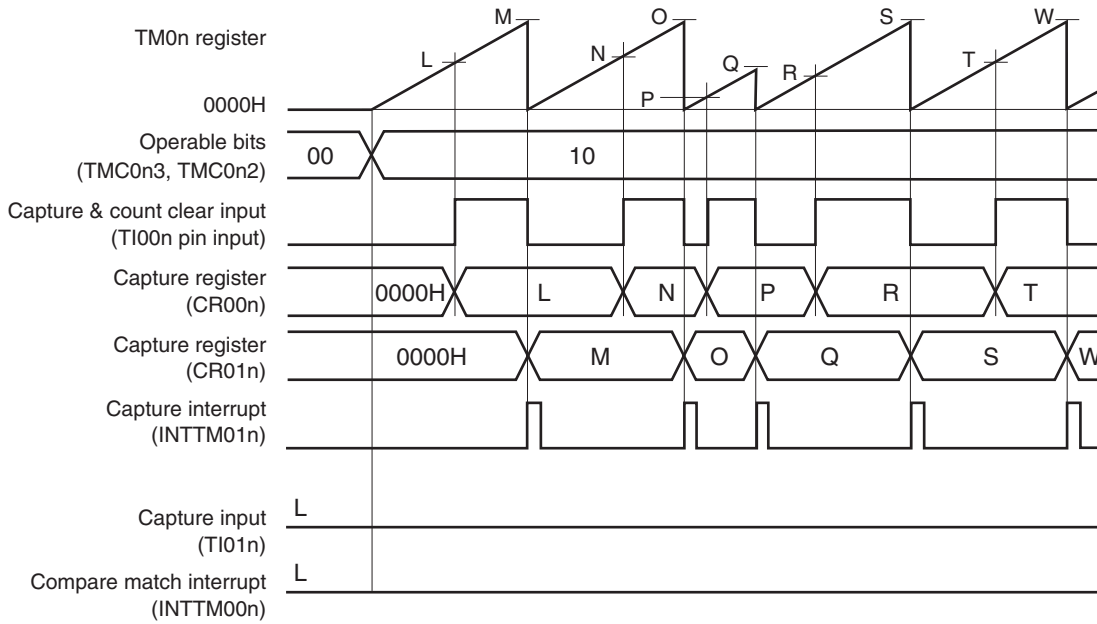
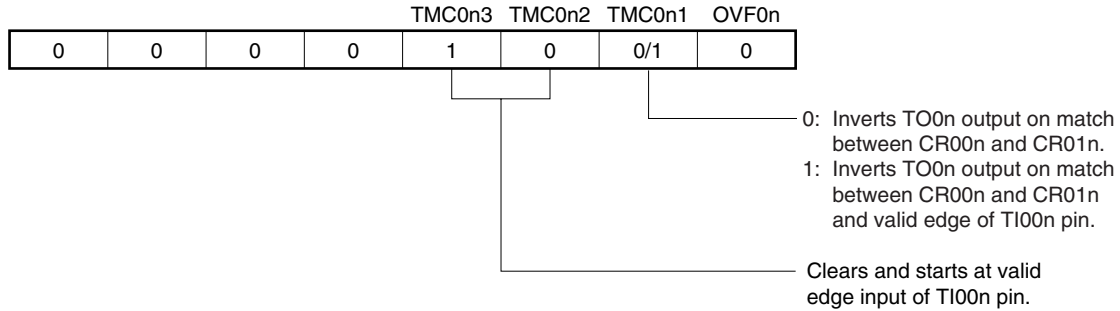
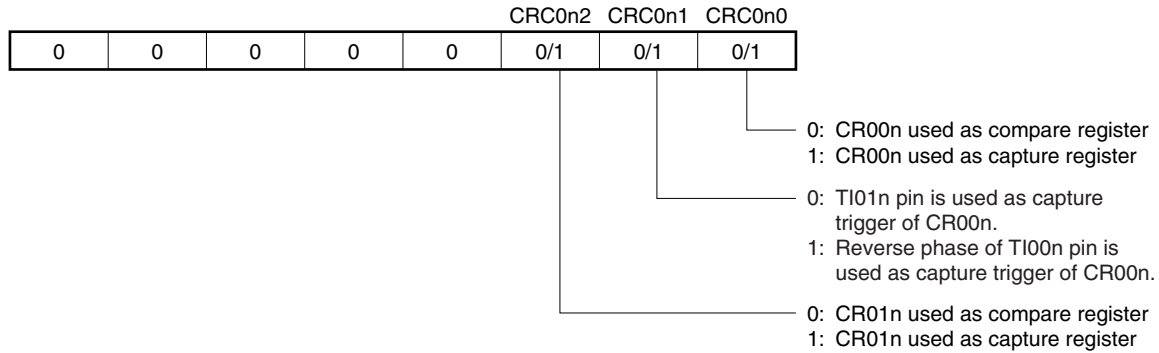

Figure 7-35. Example of Register Settings in Clear & Start Mode Entered by TI00n Pin Valid Edge Input (1/2)

(a) 16-bit timer mode control register 0n (TMC0n)



(b) Capture/compare control register 0n (CRC0n)



(c) 16-bit timer output control register 0n (TOC0n)

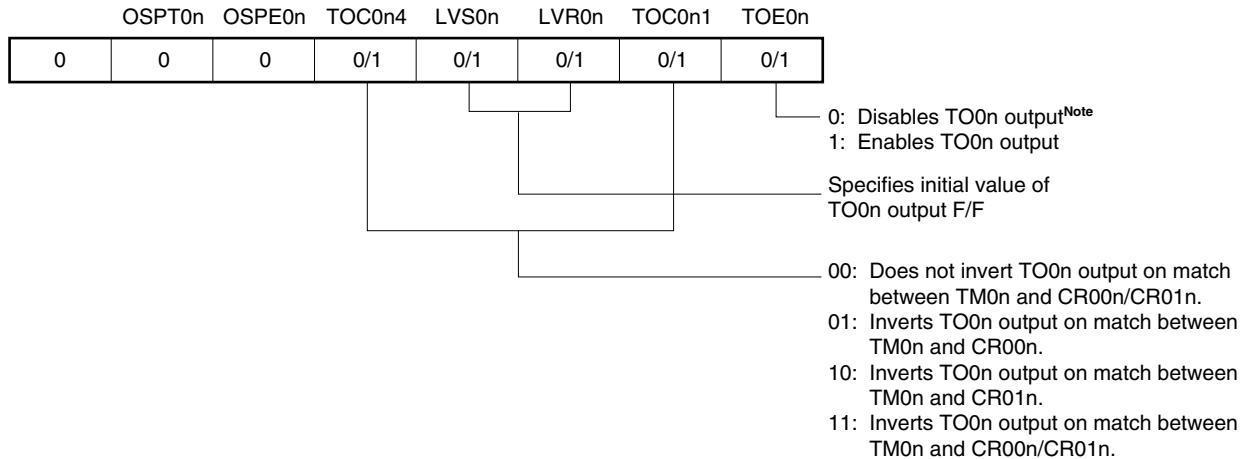

Note The timer output (TO0n) cannot be used when detecting the valid edge of the TI01n pin is used.

Remark n = 0: μ PD78F0531, 78F0532, 78F0533
 n = 0, 1: μ PD78F0534, 78F0535, 78F0536, 78F0537, 78F0537D

Figure 7-35. Example of Register Settings in Clear & Start Mode Entered by TI00n Pin Valid Edge Input (2/2)

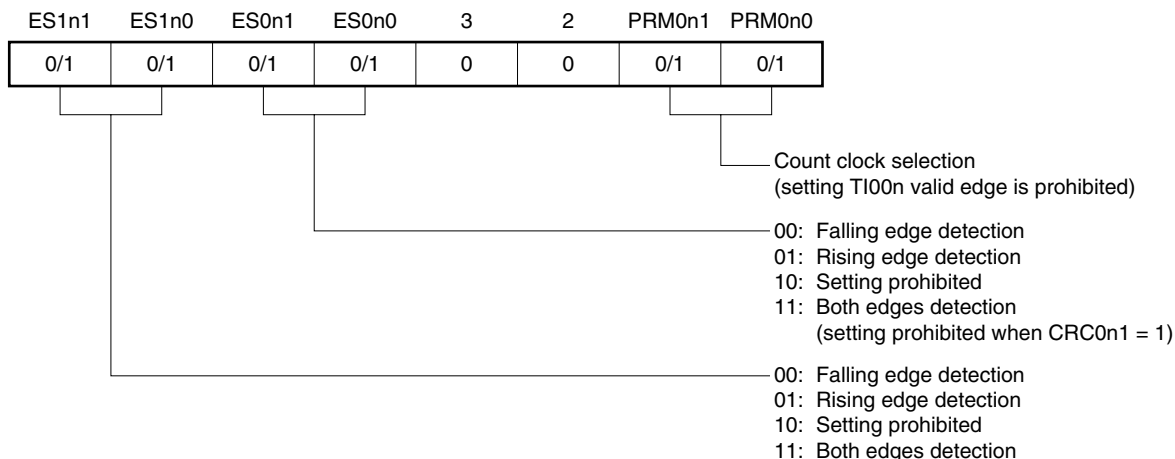
(d) Prescaler mode register 0n (PRM0n)**(e) 16-bit timer counter 0n (TM0n)**

By reading TM0n, the count value can be read.

(f) 16-bit capture/compare register 00n (CR00n)

When this register is used as a compare register and when its value matches the count value of TM0n, an interrupt signal (INTTM00n) is generated. The count value of TM0n is not cleared.

To use this register as a capture register, select either the TI00n or TI01n pin^{Note} input as a capture trigger. When the valid edge of the capture trigger is detected, the count value of TM0n is stored in CR00n.

Note The timer output (TO0n) cannot be used when detection of the valid edge of the TI01n pin is used.

(g) 16-bit capture/compare register 01n (CR01n)

When this register is used as a compare register and when its value matches the count value of TM0n, an interrupt signal (INTTM01n) is generated. The count value of TM0n is not cleared.

When this register is used as a capture register, the TI00n pin input is used as a capture trigger. When the valid edge of the capture trigger is detected, the count value of TM0n is stored in CR01n.

Remark n = 0: μ PD78F0531, 78F0532, 78F0533
n = 0, 1: μ PD78F0534, 78F0535, 78F0536, 78F0537, 78F0537D

Figure 7-36. Example of Software Processing in Clear & Start Mode Entered by TI00n Pin Valid Edge Input

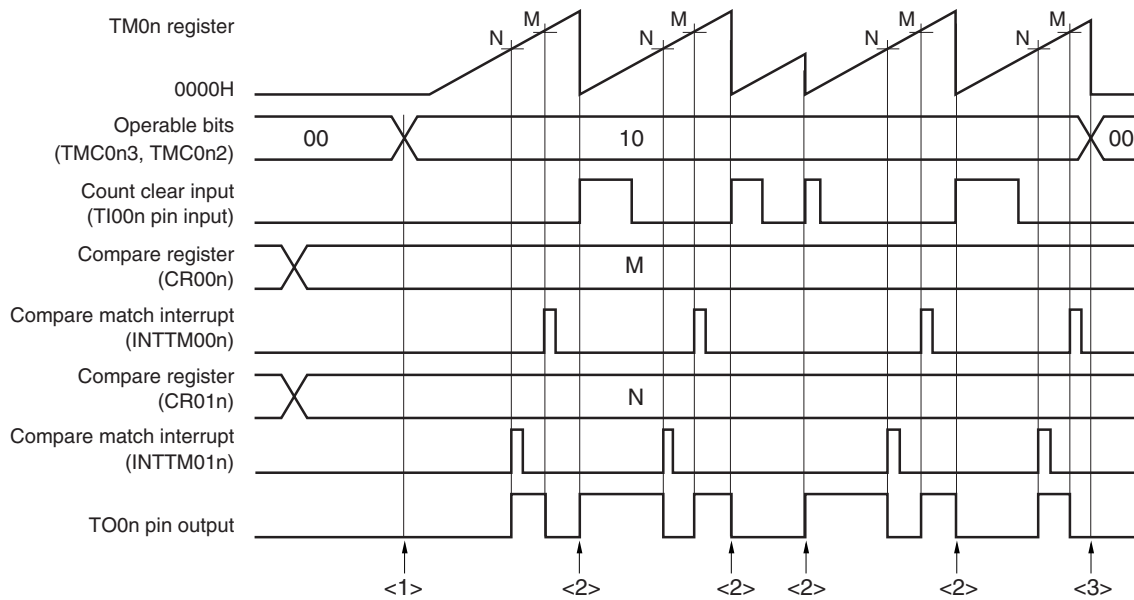

<1> Count operation start flow

<3> Count operation stop flow

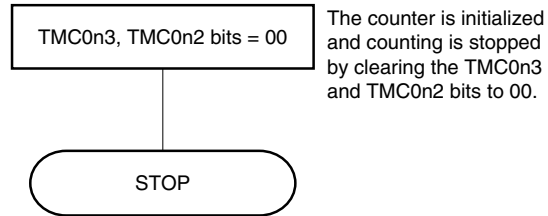
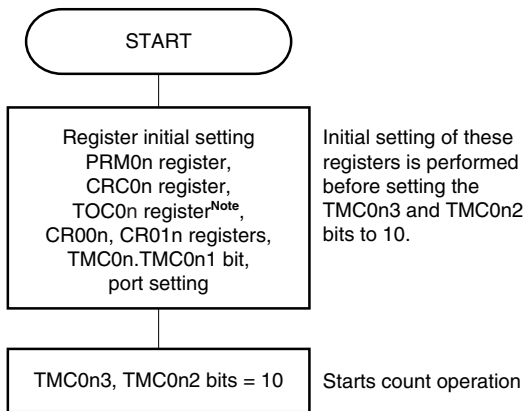

<2> TM0n register clear & start flow

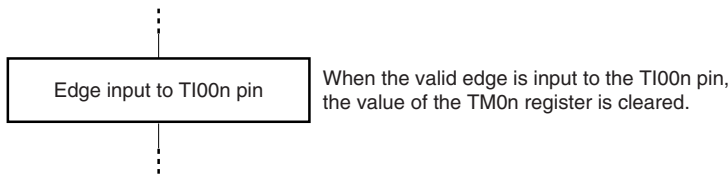

Note Care must be exercised when setting TOC0n. For details, see 7.3 (3) 16-bit timer output control register 0n (TOC0n).

Remark n = 0: μ PD78F0531, 78F0532, 78F0533
 n = 0, 1: μ PD78F0534, 78F0535, 78F0536, 78F0537, 78F0537D

7.4.5 Free-running timer operation

When bits 3 and 2 (TMC0n3 and TMC0n2) of 16-bit timer mode control register 0n (TMC0n) are set to 01 (free-running timer mode), 16-bit timer/event counter 0n continues counting up in synchronization with the count clock. When it has counted up to FFFFH, the overflow flag (OVF0n) is set to 1 at the next clock, and TM0n is cleared (to 0000H) and continues counting. Clear OVF0n to 0 by executing the CLR instruction via software.

The following three types of free-running timer operations are available.

- Both CR00n and CR01n are used as compare registers.
- One of CR00n or CR01n is used as a compare register and the other is used as a capture register.
- Both CR00n and CR01n are used as capture registers.

Remarks 1. For the setting of the I/O pins, see **7.3 (5) Port mode register 0 (PM0)**.

2. For how to enable the INTTM00n signal interrupt, see **CHAPTER 19 INTERRUPT FUNCTIONS**.

(1) Free-running timer mode operation

(CR00n: compare register, CR01n: compare register)

**Figure 7-37. Block Diagram of Free-Running Timer Mode
(CR00n: Compare Register, CR01n: Compare Register)**

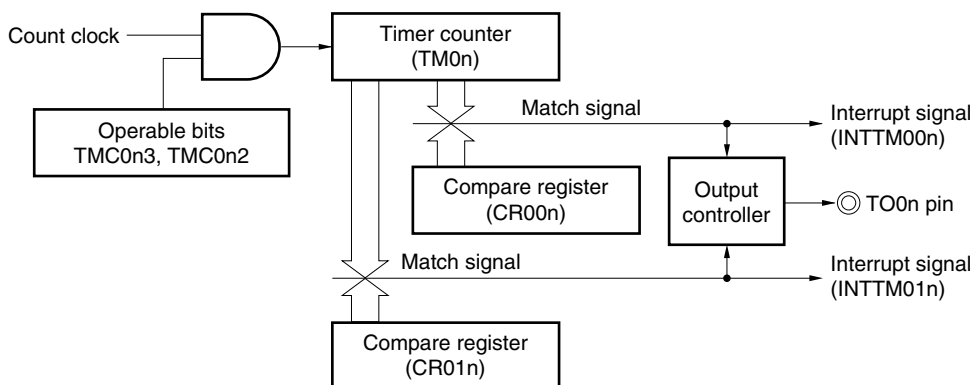

Remark n = 0: μ PD78F0531, 78F0532, 78F0533

n = 0, 1: μ PD78F0534, 78F0535, 78F0536, 78F0537, 78F0537D

**Figure 7-38. Timing Example of Free-Running Timer Mode
(CR00n: Compare Register, CR01n: Compare Register)**

• TOC0n = 13H, PRM0n = 00H, CRC0n = 00H, TMC0n = 04H

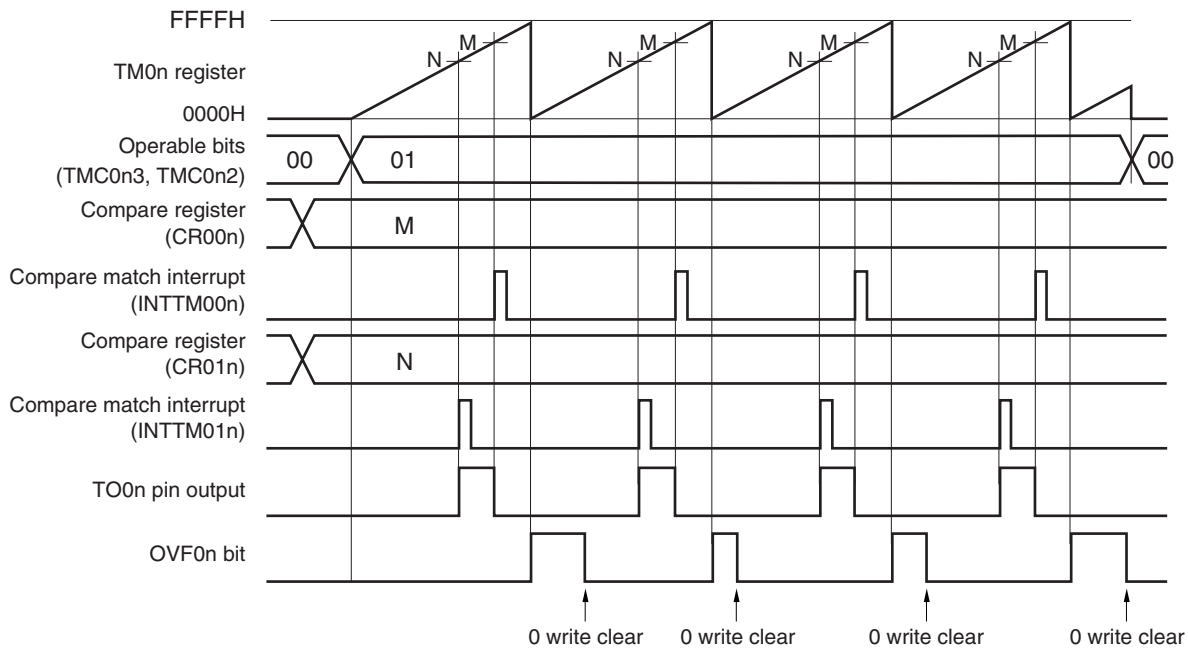

This is an application example where two compare registers are used in the free-running timer mode. The output level of the TO0n pin is reversed each time the count value of TM0n matches the set value of CR00n or CR01n. When the count value matches the register value, the INTTM00n or INTTM01n signal is generated.

Remark n = 0: μ PD78F0531, 78F0532, 78F0533
 n = 0, 1: μ PD78F0534, 78F0535, 78F0536, 78F0537, 78F0537D

**(2) Free-running timer mode operation
(CR00n: compare register, CR01n: capture register)**

**Figure 7-39. Block Diagram of Free-Running Timer Mode
(CR00n: Compare Register, CR01n: Capture Register)**

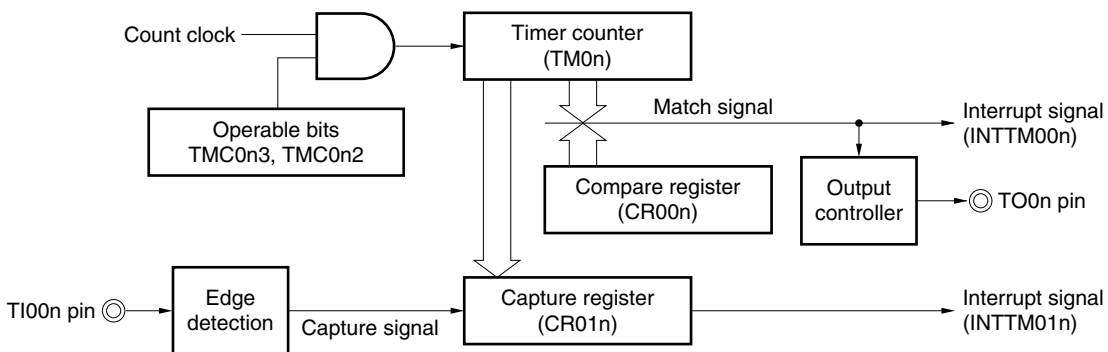

Remark n = 0: μ PD78F0531, 78F0532, 78F0533
 n = 0, 1: μ PD78F0534, 78F0535, 78F0536, 78F0537, 78F0537D

**Figure 7-40. Timing Example of Free-Running Timer Mode
(CR00n: Compare Register, CR01n: Capture Register)**

• TOC0n = 13H, PRM0n = 10H, CRC0n = 04H, TMC0n = 04H

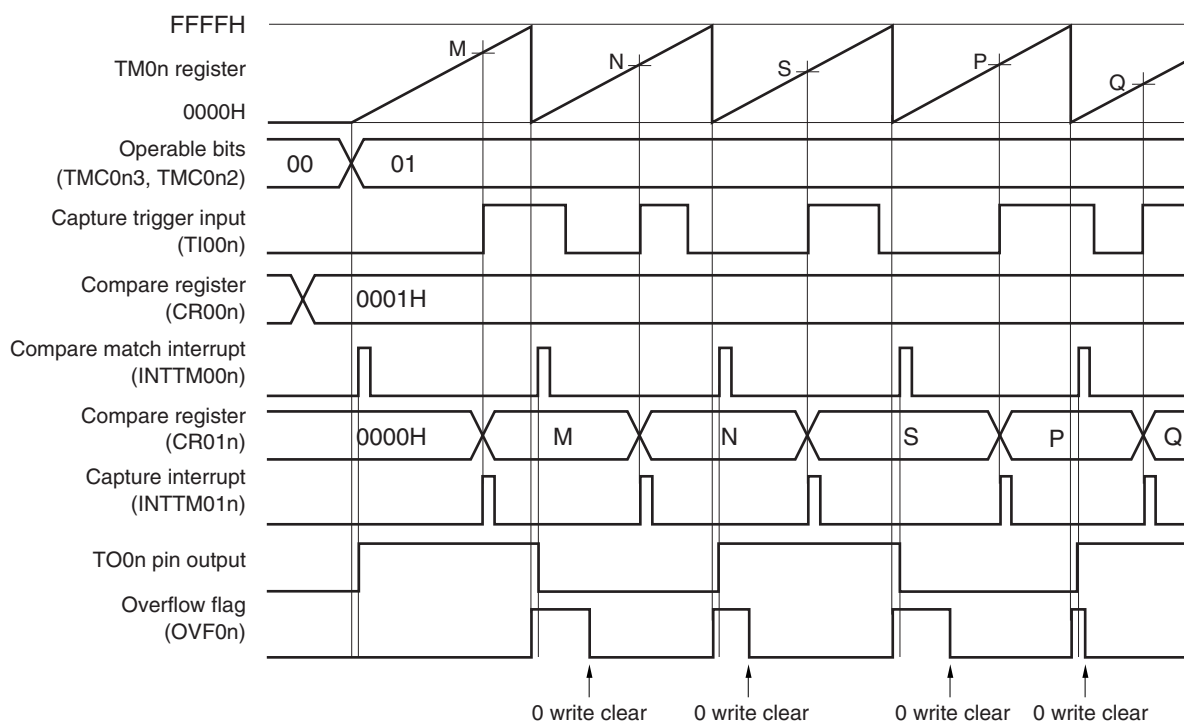

This is an application example where a compare register and a capture register are used at the same time in the free-running timer mode.

In this example, the INTTM00n signal is generated and the output level of the TO0n pin is reversed each time the count value of TM0n matches the set value of CR00n (compare register). In addition, the INTTM01n signal is generated and the count value of TM0n is captured to CR01n each time the valid edge of the TI00n pin is detected.

Remark n = 0: μ PD78F0531, 78F0532, 78F0533

n = 0, 1: μ PD78F0534, 78F0535, 78F0536, 78F0537, 78F0537D

(3) Free-running timer mode operation
(CR00n: capture register, CR01n: capture register)

Figure 7-41. Block Diagram of Free-Running Timer Mode
(CR00n: Capture Register, CR01n: Capture Register)

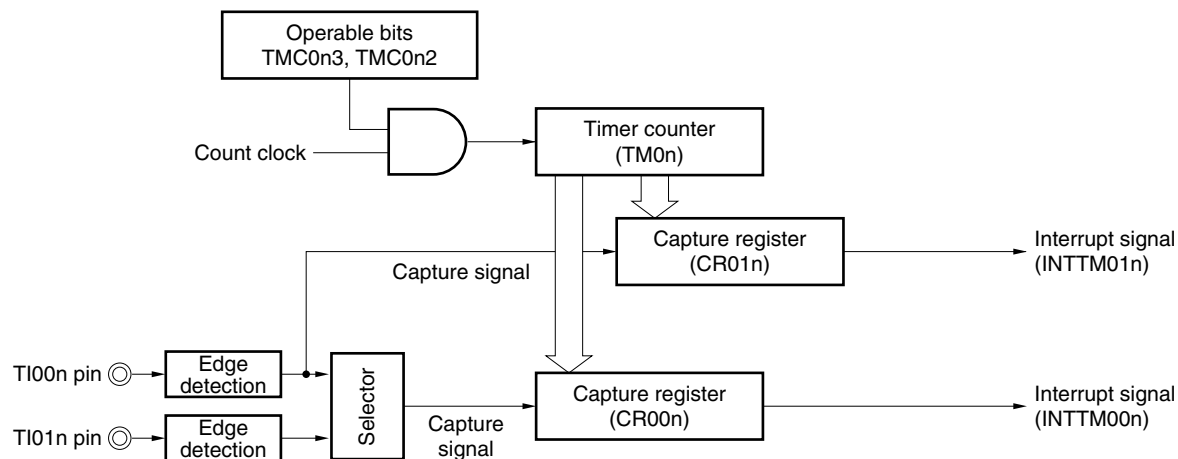

- Remarks**
- If both CR00n and CR01n are used as capture registers in the free-running timer mode, the output level of the TO0n pin is not inverted. However, it can be inverted each time the valid edge of the TI00n pin is detected if bit 1 (TMC0n1) of 16-bit timer mode control register 0n (TMC0n) is set to 1.
 - n = 0: μ PD78F0531, 78F0532, 78F0533
n = 0, 1: μ PD78F0534, 78F0535, 78F0536, 78F0537, 78F0537D

**Figure 7-42. Timing Example of Free-Running Timer Mode
(CR00n: Capture Register, CR01n: Capture Register) (1/2)**

(a) TOC0n = 13H, PRM0n = 50H, CRC0n = 05H, TMC0n = 04H

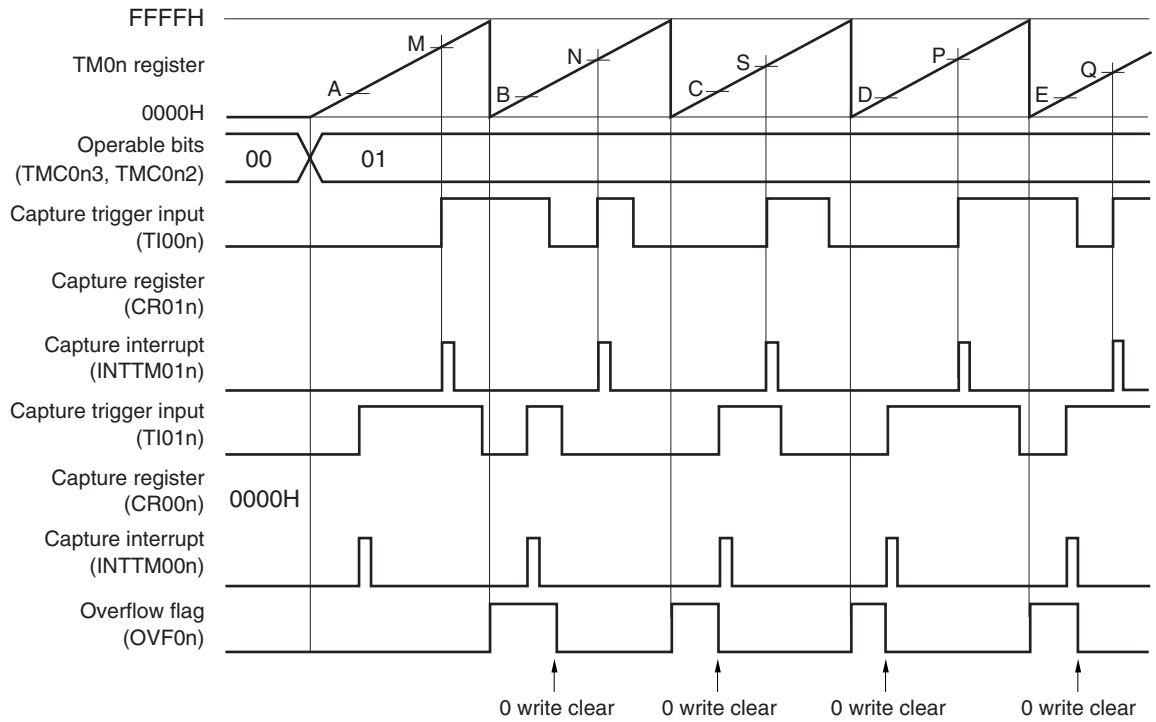

**Figure 7-42. Timing Example of Free-Running Timer Mode
(CR00n: Capture Register, CR01n: Capture Register) (2/2)**

(b) TOC0n = 13H, PRM0n = C0H, CRC0n = 05H, TMC0n = 04H

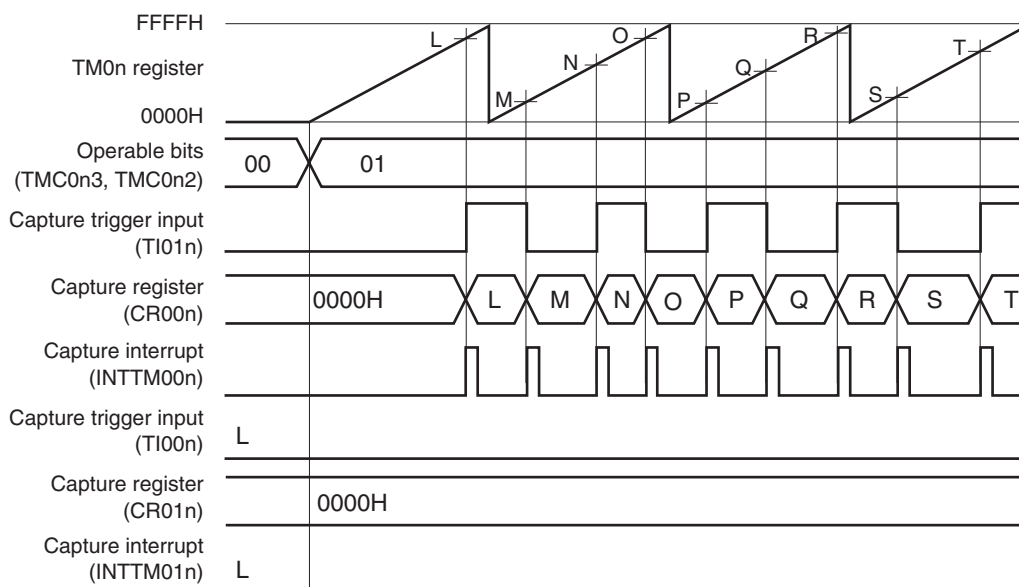

This is an application example where both the edges of the TI01n pin are detected and the count value is captured to CR00n in the free-running timer mode.

When both CR00n and CR01n are used as capture registers and when the valid edge of only the TI01n pin is to be detected, the count value cannot be captured to CR01n.

Remark n = 0: μ PD78F0531, 78F0532, 78F0533
 n = 0, 1: μ PD78F0534, 78F0535, 78F0536, 78F0537, 78F0537D

Figure 7-43. Example of Register Settings in Free-Running Timer Mode (1/2)

(a) 16-bit timer mode control register 0n (TMC0n)

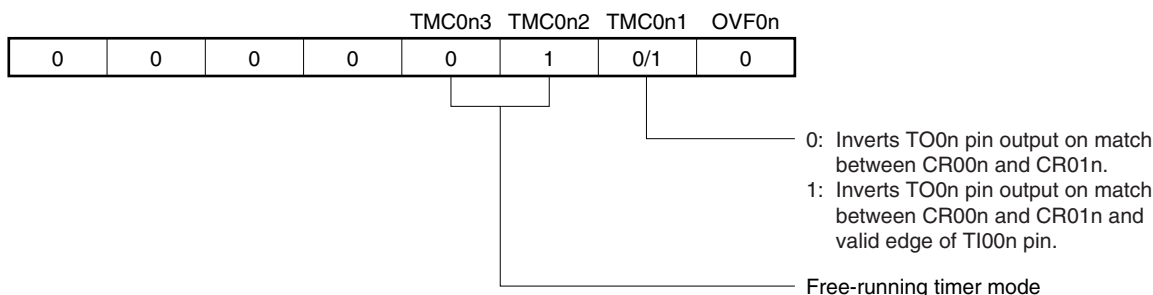

(b) Capture/compare control register 0n (CRC0n)

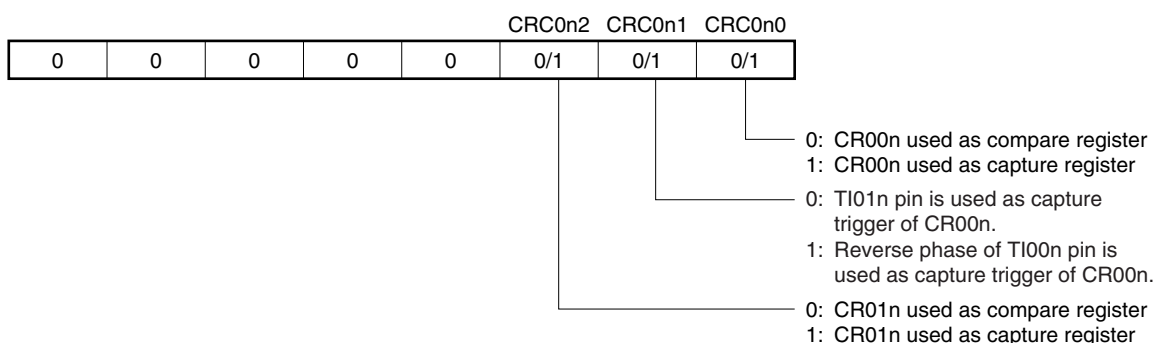

(c) 16-bit timer output control register 0n (TOC0n)

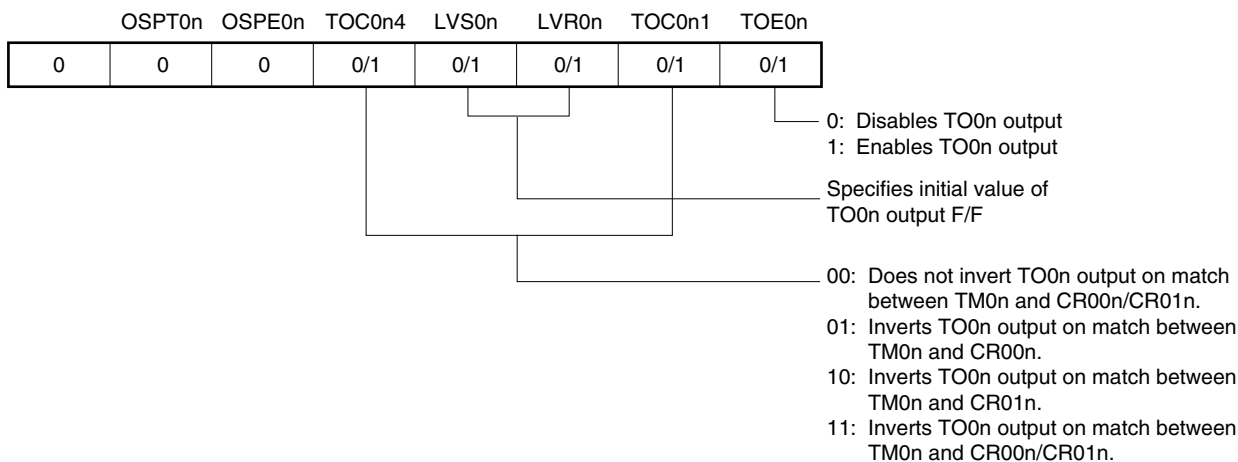

Remark n = 0: μ PD78F0531, 78F0532, 78F0533
 n = 0, 1: μ PD78F0534, 78F0535, 78F0536, 78F0537, 78F0537D

Figure 7-43. Example of Register Settings in Free-Running Timer Mode (2/2)

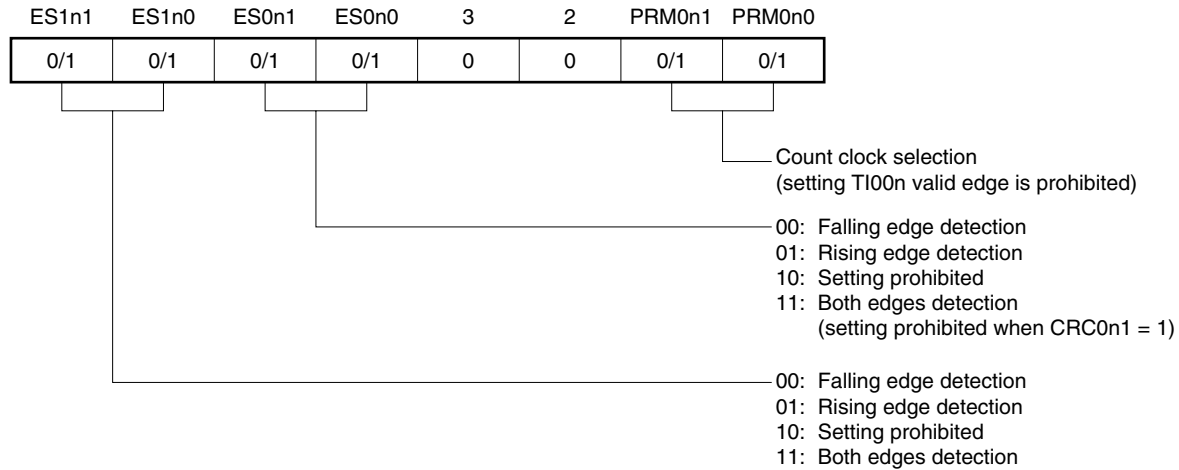
(d) Prescaler mode register 0n (PRM0n)**(e) 16-bit timer counter 0n (TM0n)**

By reading TM0n, the count value can be read.

(f) 16-bit capture/compare register 00n (CR00n)

When this register is used as a compare register and when its value matches the count value of TM0n, an interrupt signal (INTTM00n) is generated. The count value of TM0n is not cleared.

To use this register as a capture register, select either the TI00n or TI01n pin input as a capture trigger. When the valid edge of the capture trigger is detected, the count value of TM0n is stored in CR00n.

(g) 16-bit capture/compare register 01n (CR01n)

When this register is used as a compare register and when its value matches the count value of TM0n, an interrupt signal (INTTM01n) is generated. The count value of TM0n is not cleared.

When this register is used as a capture register, the TI00n pin input is used as a capture trigger. When the valid edge of the capture trigger is detected, the count value of TM0n is stored in CR01n.

Remark n = 0: μ PD78F0531, 78F0532, 78F0533

n = 0, 1: μ PD78F0534, 78F0535, 78F0536, 78F0537, 78F0537D

Figure 7-44. Example of Software Processing in Free-Running Timer Mode

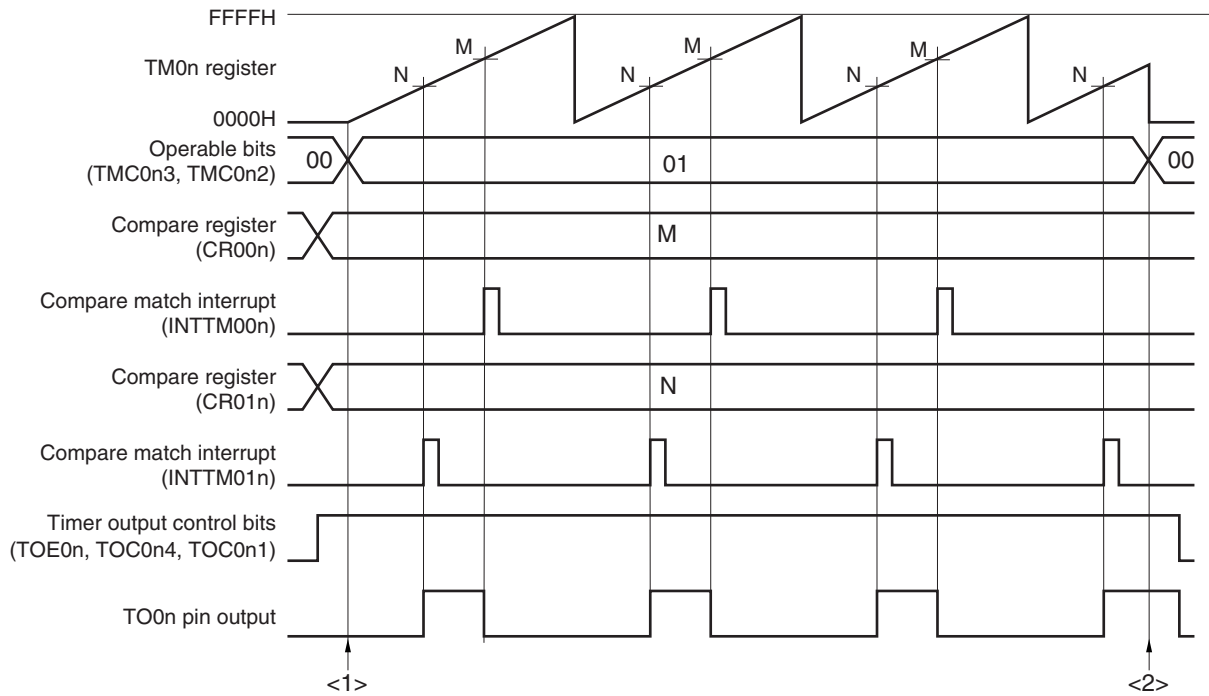

<1> Count operation start flow

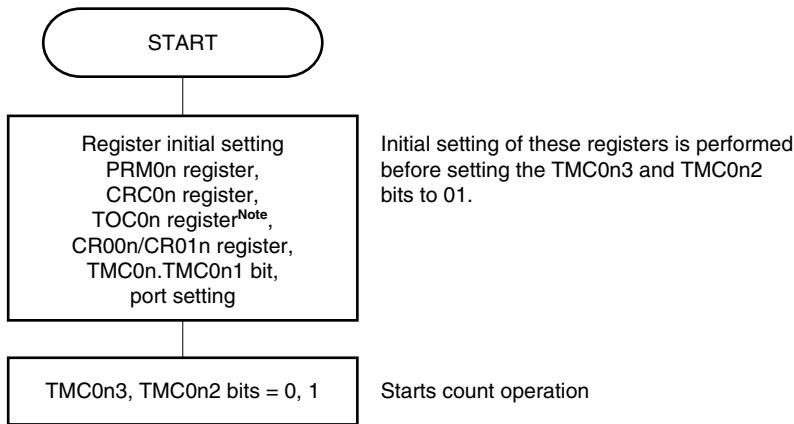

<2> Count operation stop flow

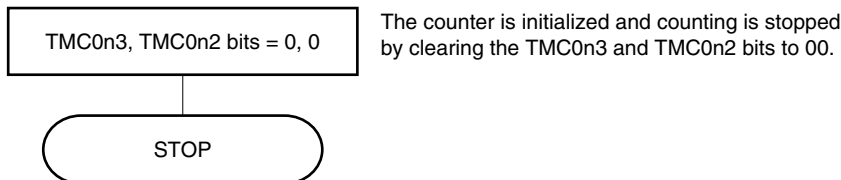

Note Care must be exercised when setting TOC0n. For details, see 7.3 (3) 16-bit timer output control register 0n (TOC0n).

Remark n = 0: μ PD78F0531, 78F0532, 78F0533
 n = 0, 1: μ PD78F0534, 78F0535, 78F0536, 78F0537, 78F0537D

7.4.6 PPG output operation

A square wave having a pulse width set in advance by CR01n is output from the TO0n pin as a PPG (Programmable Pulse Generator) signal during a cycle set by CR00n when bits 3 and 2 (TMC0n3 and TMC0n2) of 16-bit timer mode control register 0n (TMC0n) are set to 11 (clear & start upon a match between TM0n and CR00n).

The pulse cycle and duty factor of the pulse generated as the PPG output are as follows.

- Pulse cycle = (Set value of CR00n + 1) × Count clock cycle
- Duty = (Set value of CR01n + 1) / (Set value of CR00n + 1)

Caution To change the duty factor (value of CR01n) during operation, see 7.5.1 Rewriting CR01n during TM0n operation.

- Remarks**
1. For the setting of I/O pins, see 7.3 (5) Port mode register 0 (PM0).
 2. For how to enable the INTTM00n signal interrupt, see CHAPTER 19 INTERRUPT FUNCTIONS.

Figure 7-45. Block Diagram of PPG Output Operation

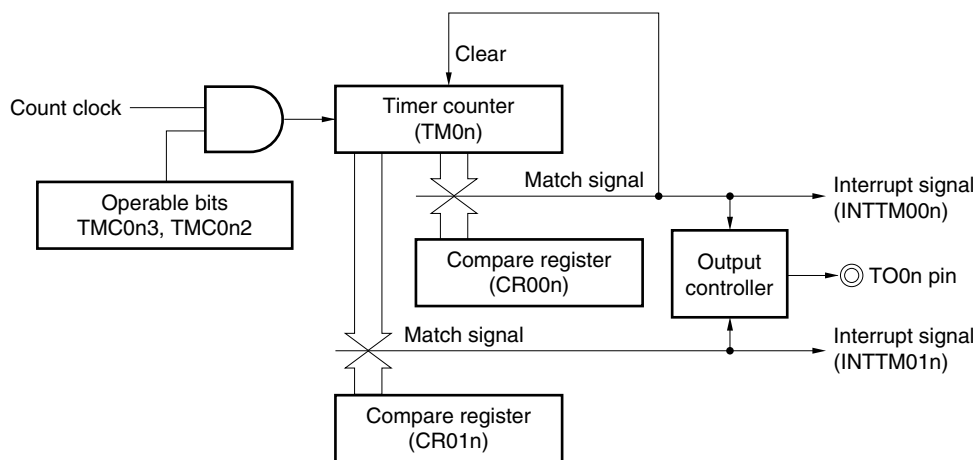

- Remark**
- n = 0: μ PD78F0531, 78F0532, 78F0533
 - n = 0, 1: μ PD78F0534, 78F0535, 78F0536, 78F0537, 78F0537D

Figure 7-46. Example of Register Settings for PPG Output Operation

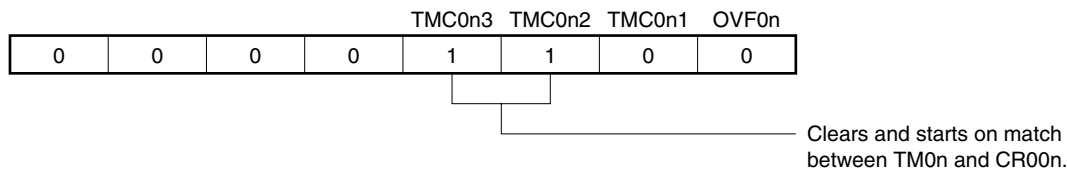
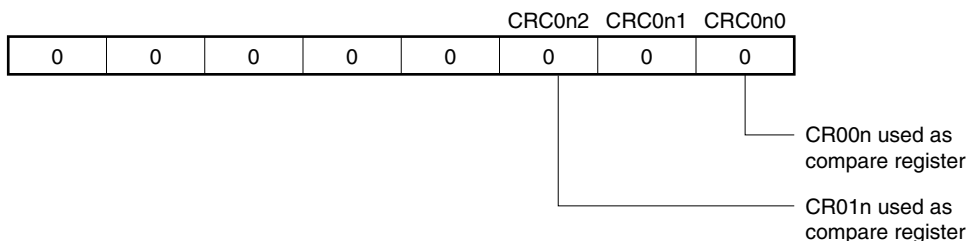
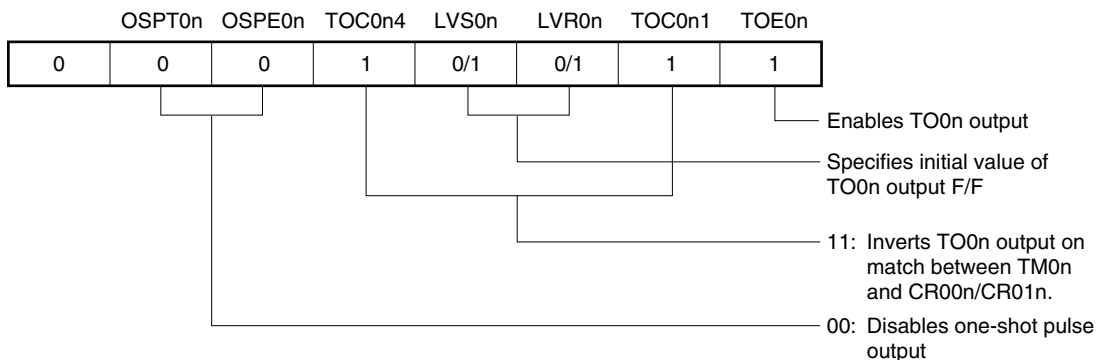
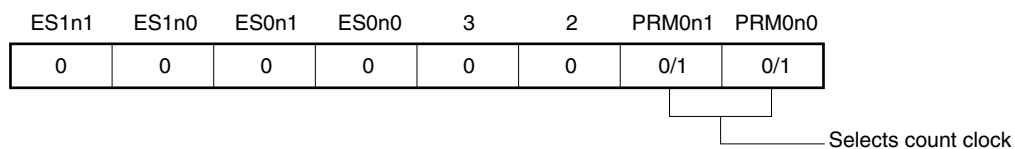
(a) 16-bit timer mode control register 0n (TMC0n)

(b) Capture/compare control register 0n (CRC0n)

(c) 16-bit timer output control register 0n (TOC0n)

(d) Prescaler mode register 0n (PRM0n)

(e) 16-bit timer counter 0n (TM0n)

By reading TM0n, the count value can be read.

(f) 16-bit capture/compare register 00n (CR00n)

An interrupt signal (INTTM00n) is generated when the value of this register matches the count value of TM0n. The count value of TM0n is not cleared.

(g) 16-bit capture/compare register 01n (CR01n)

An interrupt signal (INTTM01n) is generated when the value of this register matches the count value of TM0n. The count value of TM0n is not cleared.

Caution Set values to CR00n and CR01n such that the condition $0000H < CR01n < CR00n \leq FFFFH$ is satisfied.

Remark n = 0: μ PD78F0531, 78F0532, 78F0533
 n = 0, 1: μ PD78F0534, 78F0535, 78F0536, 78F0537, 78F0537D

Figure 7-47. Example of Software Processing for PPG Output Operation

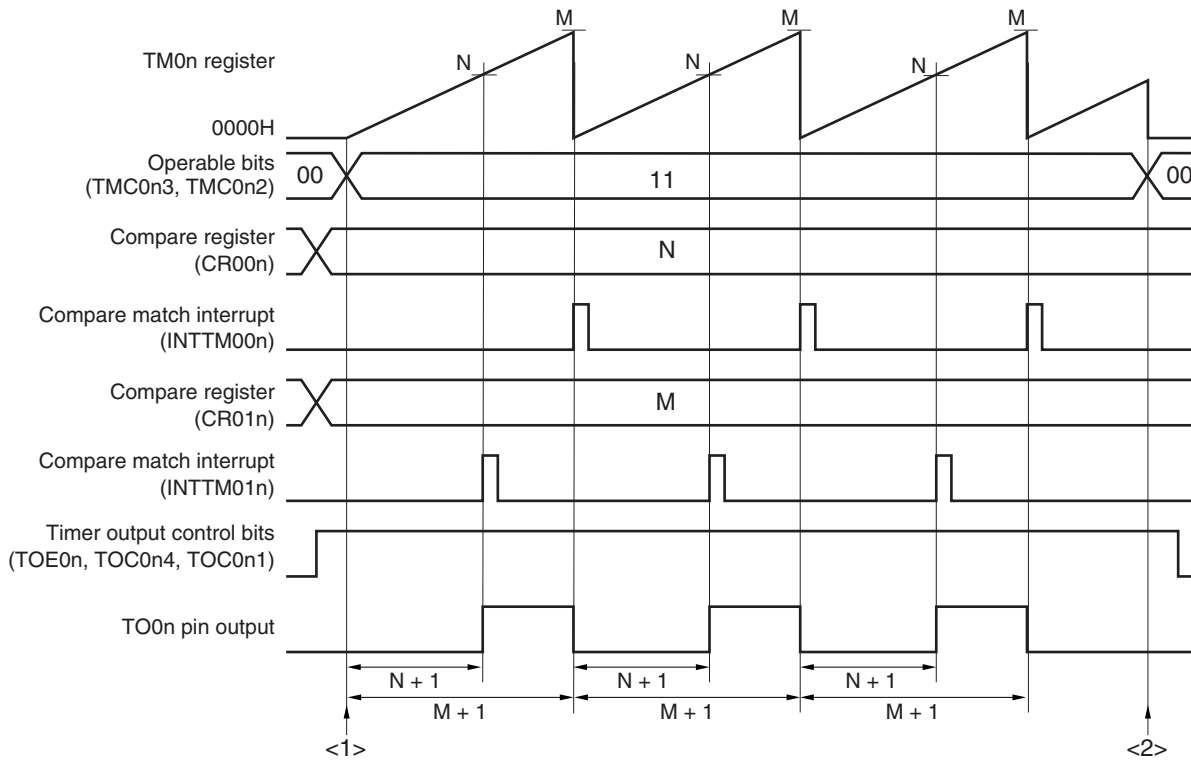

<1> Count operation start flow

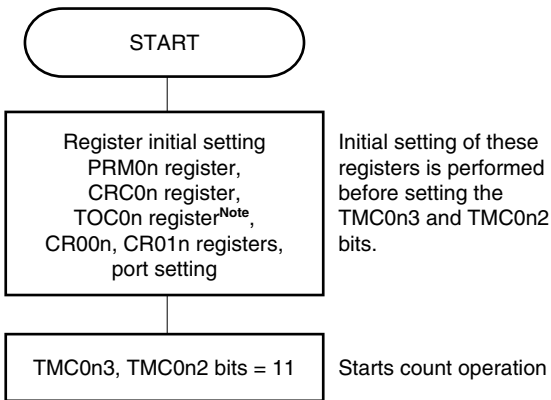

<2> Count operation stop flow

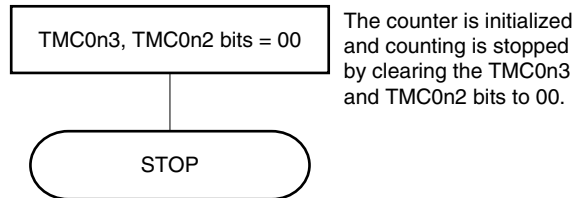

Note Care must be exercised when setting TOC0n. For details, see 7.3 (3) 16-bit timer output control register 0n (TOC0n).

Remarks 1. PPG pulse cycle = $(M + 1) \times$ Count clock cycle
 PPG duty = $(N + 1)/(M + 1)$

2. n = 0: μ PD78F0531, 78F0532, 78F0533
- n = 0, 1: μ PD78F0534, 78F0535, 78F0536, 78F0537, 78F0537D

7.4.7 One-shot pulse output operation

A one-shot pulse can be output by setting bits 3 and 2 (TMC0n3 and TMC0n2) of the 16-bit timer mode control register 0n (TMC0n) to 01 (free-running timer mode) or to 10 (clear & start mode entered by the TI00n pin valid edge) and setting bit 5 (OSPE0n) of 16-bit timer output control register 0n (TOC0n) to 1.

When bit 6 (OSPT0n) of TOC0n is set to 1 or when the valid edge is input to the TI00n pin during timer operation, clearing & starting of TM0n is triggered, and a pulse of the difference between the values of CR00n and CR01n is output only once from the TO0n pin.

- Cautions**
1. Do not input the trigger again (setting OSPT0n to 1 or detecting the valid edge of the TI00n pin) while the one-shot pulse is output. To output the one-shot pulse again, generate the trigger after the current one-shot pulse output has completed.
 2. To use only the setting of OSPT0n to 1 as the trigger of one-shot pulse output, do not change the level of the TI00n pin or its alternate function port pin. Otherwise, the pulse will be unexpectedly output.

- Remarks**
1. For the setting of the I/O pins, see 7.3 (5) Port mode register 0 (PM0).
 2. For how to enable the INTTM00n signal interrupt, see CHAPTER 19 INTERRUPT FUNCTIONS.

Figure 7-48. Block Diagram of One-Shot Pulse Output Operation

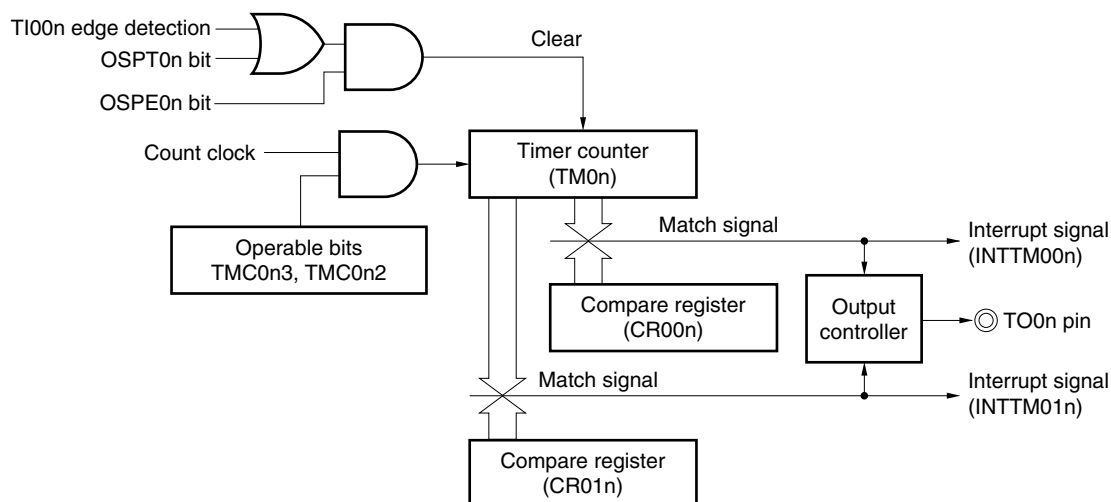

- Remark**
- n = 0: μ PD78F0531, 78F0532, 78F0533
 n = 0, 1: μ PD78F0534, 78F0535, 78F0536, 78F0537, 78F0537D

Figure 7-49. Example of Register Settings for One-Shot Pulse Output Operation (1/2)

(a) 16-bit timer mode control register 0n (TMC0n)

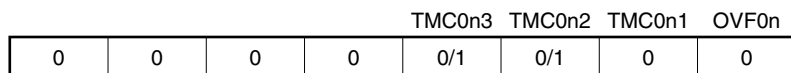

01: Free running timer mode
10: Clear and start mode by valid edge of T100n pin.

(b) Capture/compare control register 0n (CRC0n)



CR00n used as compare register

CR01n used as compare register

(c) 16-bit timer output control register 0n (TOC0n)

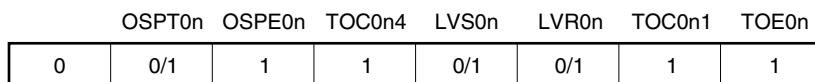

Enables TO0n pin output

Specifies initial value of TO0n pin output

Inverts TO0n output on match between TM0n and CR00n/CR01n.

Enables one-shot pulse output

Software trigger is generated by writing 1 to this bit (operation is not affected even if 0 is written to it).

(d) Prescaler mode register 0n (PRM0n)

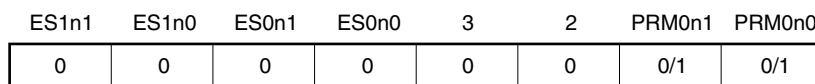

Selects count clock

Remark n = 0: μ PD78F0531, 78F0532, 78F0533
n = 0, 1: μ PD78F0534, 78F0535, 78F0536, 78F0537, 78F0537D

Figure 7-49. Example of Register Settings for One-Shot Pulse Output Operation (2/2)**(e) 16-bit timer counter 0n (TM0n)**

By reading TM0n, the count value can be read.

(f) 16-bit capture/compare register 00n (CR00n)

This register is used as a compare register when a one-shot pulse is output. When the value of TM0n matches that of CR00n, an interrupt signal (INTTM00n) is generated and the output level of the TO0n pin is inverted.

(g) 16-bit capture/compare register 01n (CR01n)

This register is used as a compare register when a one-shot pulse is output. When the value of TM0n matches that of CR01n, an interrupt signal (INTTM01n) is generated and the output level of the TO0n pin is inverted.

Caution Do not set identical values or 0000H for CR0n0 and CR0n1.

Remark n = 0: μ PD78F0531, 78F0532, 78F0533

n = 0, 1: μ PD78F0534, 78F0535, 78F0536, 78F0537, 78F0537D

Figure 7-50. Example of Software Processing for One-Shot Pulse Output Operation (1/2)

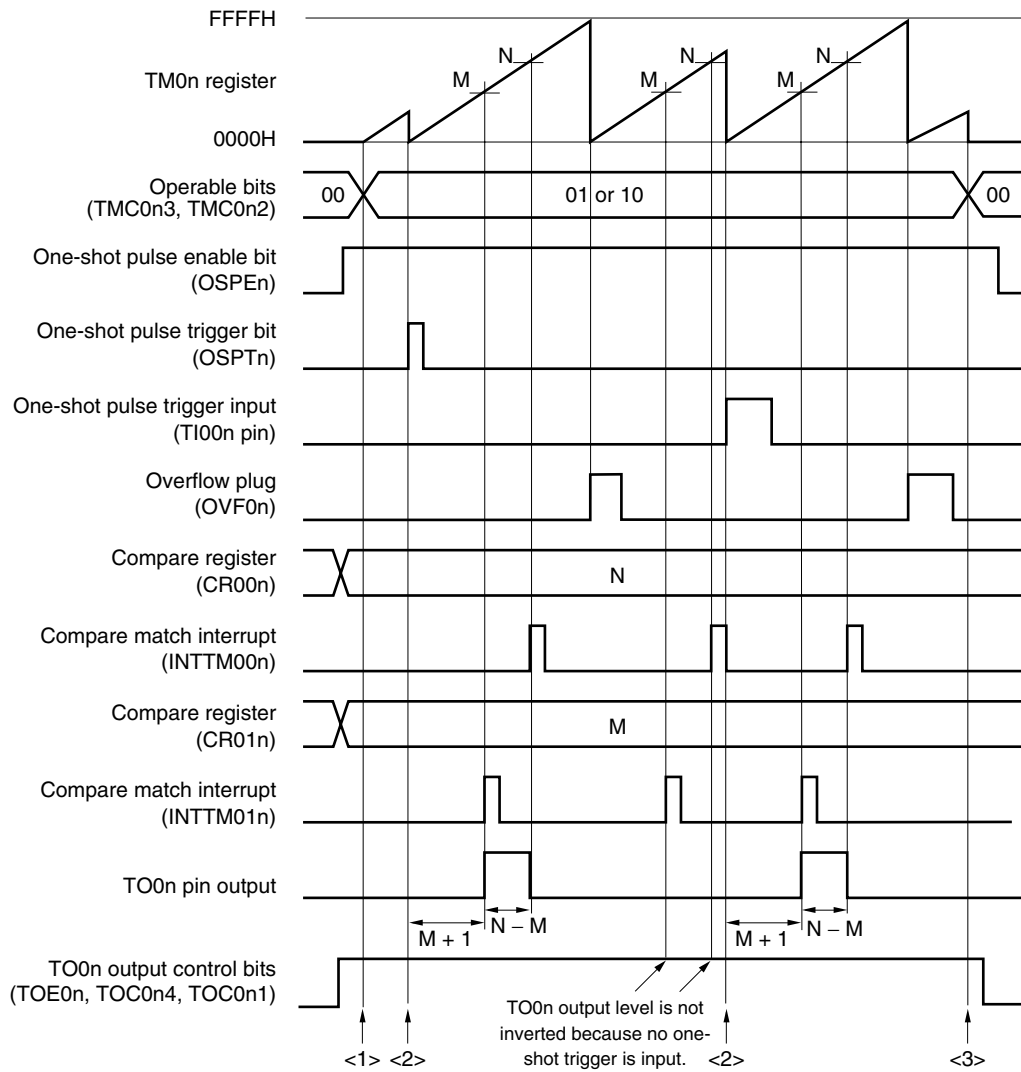

- Time from when the one-shot pulse trigger is input until the one-shot pulse is output
= $(M + 1) \times \text{Count clock cycle}$
- One-shot pulse output active level width
= $(N - M) \times \text{Count clock cycle}$

Remark n = 0: $\mu\text{PD78F0531, 78F0532, 78F0533}$
 n = 0, 1: $\mu\text{PD78F0534, 78F0535, 78F0536, 78F0537, 78F0537D}$

Figure 7-50. Example of Software Processing for One-Shot Pulse Output Operation (2/2)

<1> Count operation start flow

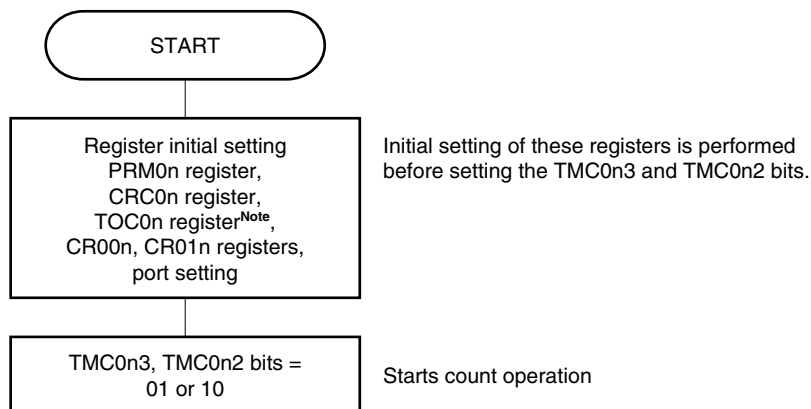

<2> One-shot trigger input flow

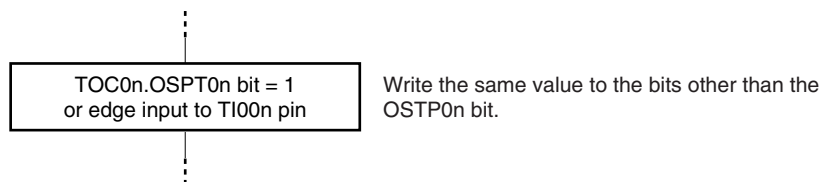

<3> Count operation stop flow

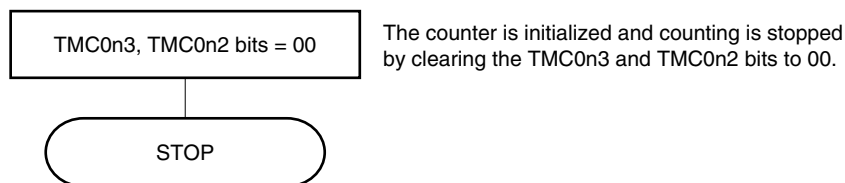

Note Care must be exercised when setting TOC0n. For details, see 7.3 (3) 16-bit timer output control register 0n (TOC0n).

Remark n = 0: μ PD78F0531, 78F0532, 78F0533
n = 0, 1: μ PD78F0534, 78F0535, 78F0536, 78F0537, 78F0537D

7.4.8 Pulse width measurement operation

TM0n can be used to measure the pulse width of the signal input to the TI00n and TI01n pins.

Measurement can be accomplished by operating the 16-bit timer/event counter 0n in the free-running timer mode or by restarting the timer in synchronization with the signal input to the TI00n pin.

When an interrupt is generated, read the value of the valid capture register and measure the pulse width. Check bit 0 (OVF0n) of 16-bit timer mode control register 0n (TMC0n). If it is set (to 1), clear it to 0 by software.

Figure 7-51. Block Diagram of Pulse Width Measurement (Free-Running Timer Mode)

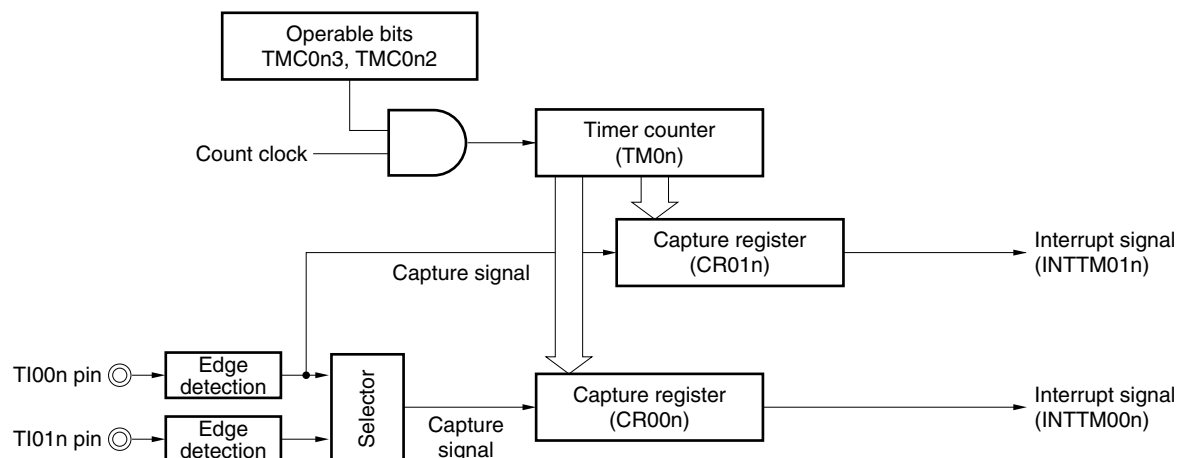

Remark n = 0: μ PD78F0531, 78F0532, 78F0533
 n = 0, 1: μ PD78F0534, 78F0535, 78F0536, 78F0537, 78F0537D

Figure 7-52. Block Diagram of Pulse Width Measurement (Clear & Start Mode Entered by TI00n Pin Valid Edge Input)

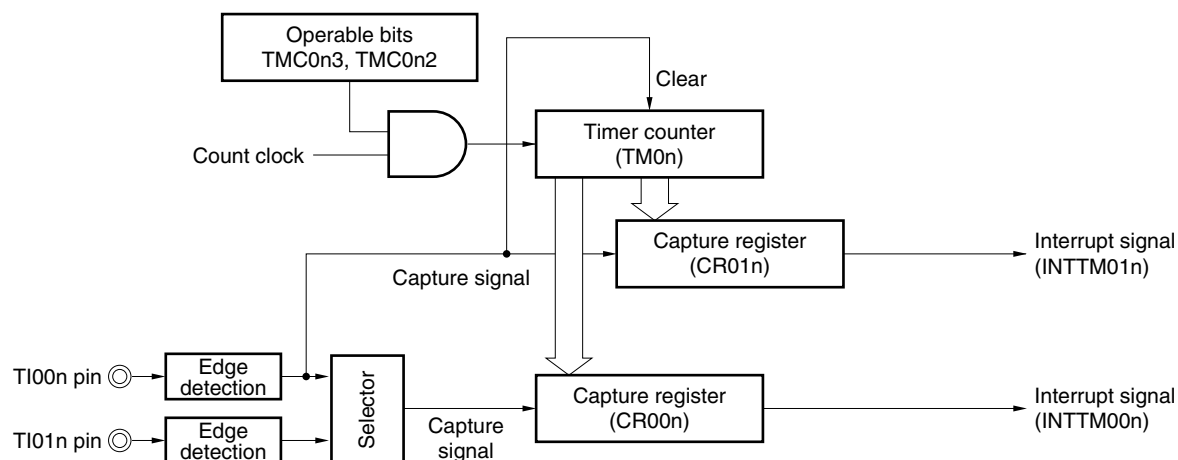

Remark n = 0: μ PD78F0531, 78F0532, 78F0533
 n = 0, 1: μ PD78F0534, 78F0535, 78F0536, 78F0537, 78F0537D

A pulse width can be measured in the following three ways.

- Measuring the pulse width by using two input signals of the TI00n and TI01n pins (free-running timer mode)
- Measuring the pulse width by using one input signal of the TI00n pin (free-running timer mode)
- Measuring the pulse width by using one input signal of the TI00n pin (clear & start mode entered by the TI00n pin valid edge input)

Remarks 1. For the setting of the I/O pins, see **7.3 (5) Port mode register 0 (PM0)**.

2. For how to enable the INTTM00n signal interrupt, see **CHAPTER 19 INTERRUPT FUNCTIONS**.

3. n = 0: μ PD78F0531, 78F0532, 78F0533

n = 0, 1: μ PD78F0534, 78F0535, 78F0536, 78F0537, 78F0537D

(1) Measuring the pulse width by using two input signals of the TI00n and TI01n pins (free-running timer mode)

Set the free-running timer mode (TMC0n3 and TMC0n2 = 01). When the valid edge of the TI00n pin is detected, the count value of TM0n is captured to CR01n. When the valid edge of the TI01n pin is detected, the count value of TM0n is captured to CR00n. Specify detection of both the edges of the TI00n and TI01n pins.

By this measurement method, the previous count value is subtracted from the count value captured by the edge of each input signal. Therefore, save the previously captured value to a separate register in advance.

If an overflow occurs, the value becomes negative if the previously captured value is simply subtracted from the current captured value and, therefore, a borrow occurs (bit 0 (CY) of the program status word (PSW) is set to 1).

If this happens, ignore CY and take the calculated value as the pulse width. In addition, clear bit 0 (OVF0n) of 16-bit timer mode control register 0n (TMC0n) to 0.

Figure 7-53. Timing Example of Pulse Width Measurement (1)

• TMC0n = 04H, PRM0n = F0H, CRC0n = 05H

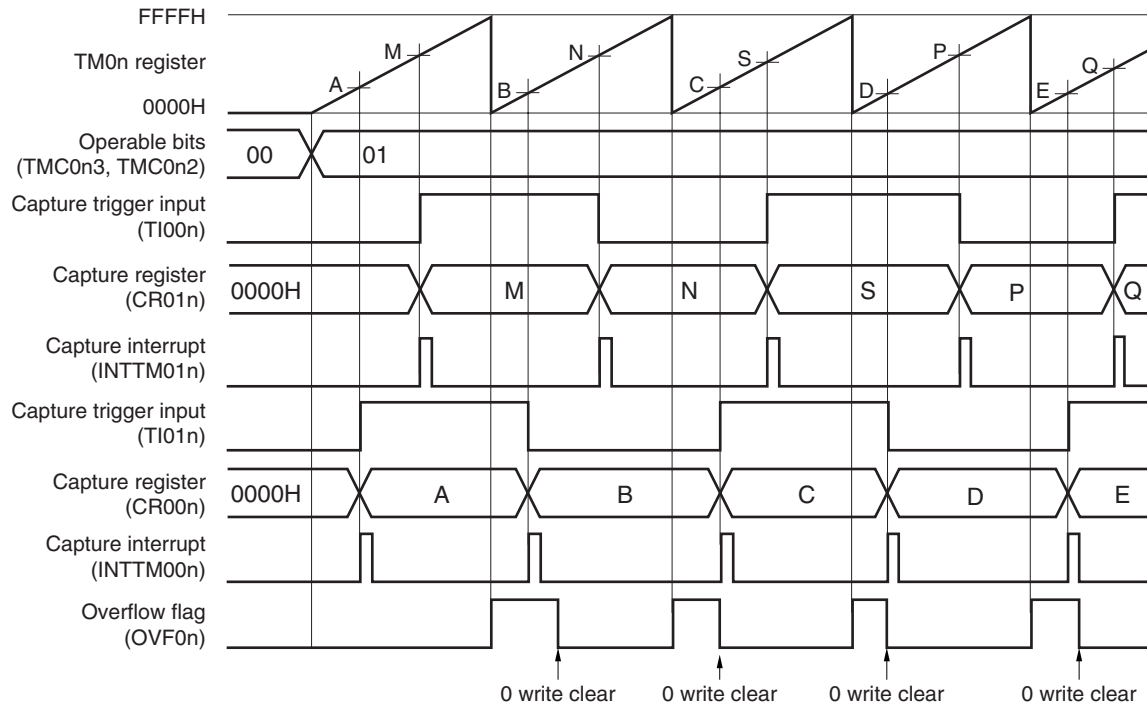

Remark n = 0: μ PD78F0531, 78F0532, 78F0533
 n = 0, 1: μ PD78F0534, 78F0535, 78F0536, 78F0537, 78F0537D

(2) Measuring the pulse width by using one input signal of the TI00n pin (free-running mode)

Set the free-running timer mode (TMC0n3 and TMC0n2 = 01). The count value of TM0n is captured to CR00n in the phase reverse to the valid edge detected on the TI00n pin. When the valid edge of the TI00n pin is detected, the count value of TM0n is captured to CR01n.

By this measurement method, values are stored in separate capture registers when a width from one edge to another is measured. Therefore, the capture values do not have to be saved. By subtracting the value of one capture register from that of another, a high-level width, low-level width, and cycle are calculated.

If an overflow occurs, the value becomes negative if one captured value is simply subtracted from another and, therefore, a borrow occurs (bit 0 (CY) of the program status word (PSW) is set to 1). If this happens, ignore CY and take the calculated value as the pulse width. In addition, clear bit 0 (OVF0n) of 16-bit timer mode control register 0n (TMC0n) to 0.

Figure 7-54. Timing Example of Pulse Width Measurement (2)

• TMC0n = 04H, PRM0n = 10H, CRC0n = 07H

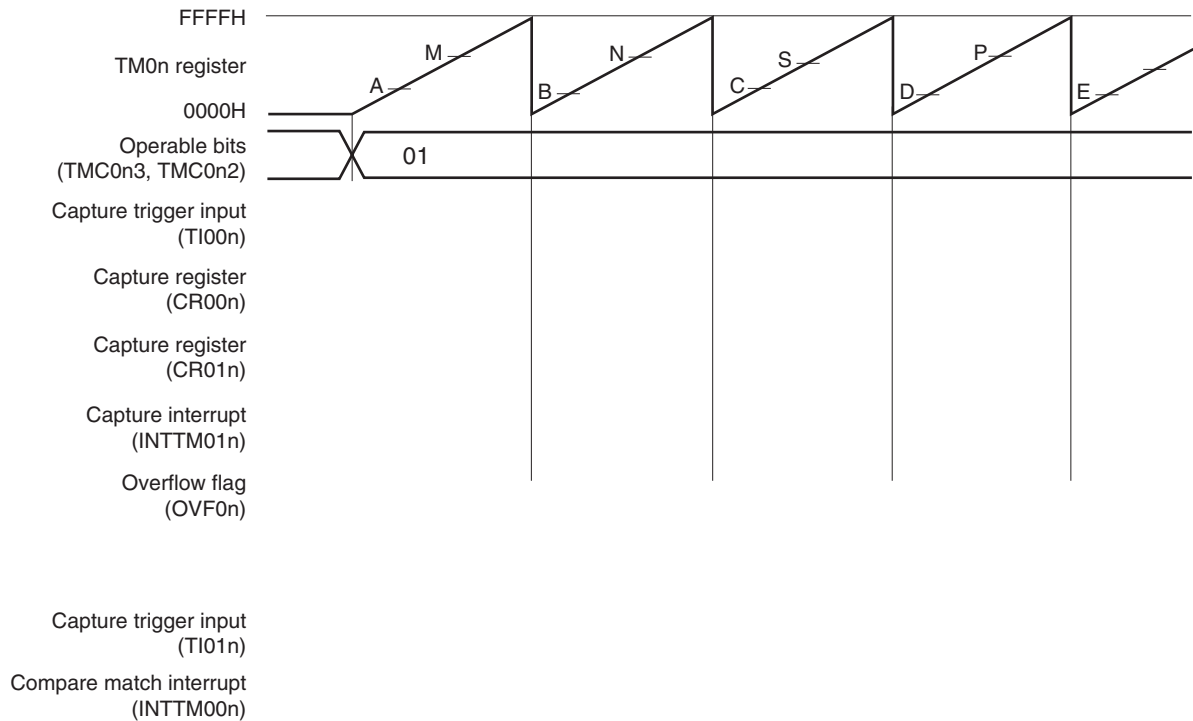

(3) Measuring the pulse width by using one input signal of the TI00n pin (clear & start mode entered by the TI00n pin valid edge input)

Set the clear & start mode entered by the TI00n pin valid edge (TMC0n3 and TMC0n2 = 10). The count value of TM0n is captured to CR00n in the phase reverse to the valid edge of the TI00n pin, and the count value of TM0n is captured to CR01n and TM0n is cleared (0000H) when the valid edge of the TI00n pin is detected. Therefore, a cycle is stored in CR01n if TM0n does not overflow.

If an overflow occurs, take the value that results from adding 10000H to the value stored in CR01n as a cycle. Clear bit 0 (OVF0n) of 16-bit timer mode control register 0n (TMC0n) to 0.

Figure 7-55. Timing Example of Pulse Width Measurement (3)

• TMC0n = 08H, PRM0n = 10H, CRC0n = 07H

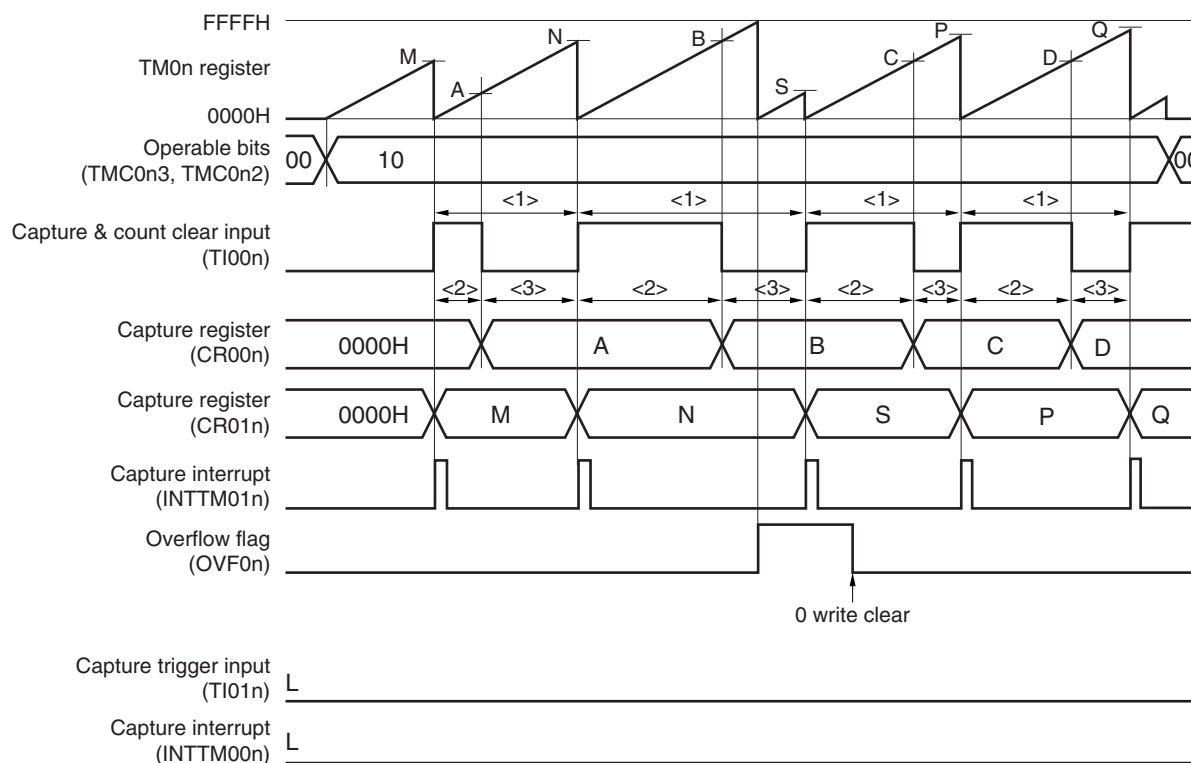

<1> Pulse cycle = $(10000H \times \text{Number of times OVF0n bit is set to 1} + \text{Captured value of CR01n}) \times \text{Count clock cycle}$

<2> High-level pulse width = $(10000H \times \text{Number of times OVF0n bit is set to 1} + \text{Captured value of CR00n}) \times \text{Count clock cycle}$

<3> Low-level pulse width = $(\text{Pulse cycle} - \text{High-level pulse width})$

Remark n = 0: μ PD78F0531, 78F0532, 78F0533
 n = 0, 1: μ PD78F0534, 78F0535, 78F0536, 78F0537, 78F0537D

Figure 7-56. Example of Register Settings for Pulse Width Measurement (1/2)

(a) 16-bit timer mode control register 0n (TMC0n)

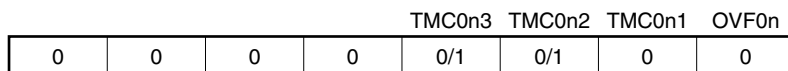

01: Free running timer mode
 10: Clear and start mode entered by valid edge of TI00n pin.

(b) Capture/compare control register 0n (CRC0n)

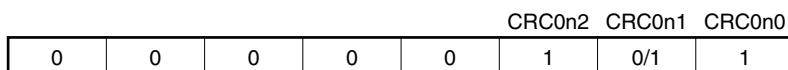

1: CR0n used as capture register
 0: TI01n pin is used as capture trigger of CR0n.
 1: Reverse phase of TI00n pin is used as capture trigger of CR0n.
 1: CR01n used as capture register

(c) 16-bit timer output control register 0n (TOC0n)

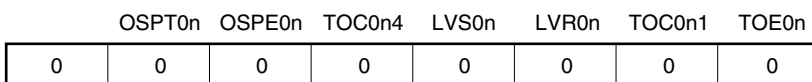

(d) Prescaler mode register 0n (PRM0n)

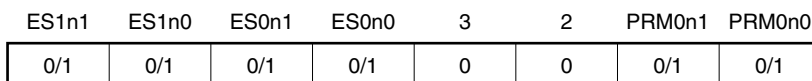

Selects count clock (setting valid edge of TI00n is prohibited)
 00: Falling edge detection
 01: Rising edge detection
 10: Setting prohibited
 11: Both edges detection (setting when CRC0n1 = 1 is prohibited)
 00: Falling edge detection
 01: Rising edge detection
 10: Setting prohibited
 11: Both edges detection

Remark n = 0: μ PD78F0531, 78F0532, 78F0533
 n = 0, 1: μ PD78F0534, 78F0535, 78F0536, 78F0537, 78F0537D

Figure 7-56. Example of Register Settings for Pulse Width Measurement (2/2)**(e) 16-bit timer counter 0n (TM0n)**

By reading TM0n, the count value can be read.

(f) 16-bit capture/compare register 00n (CR00n)

This register is used as a capture register. Either the TI00n or TI01n pin is selected as a capture trigger. When a specified edge of the capture trigger is detected, the count value of TM0n is stored in CR00n.

(g) 16-bit capture/compare register 01n (CR01n)

This register is used as a capture register. The signal input to the TI00n pin is used as a capture trigger. When the capture trigger is detected, the count value of TM0n is stored in CR01n.

Remark n = 0: μ PD78F0531, 78F0532, 78F0533

n = 0, 1: μ PD78F0534, 78F0535, 78F0536, 78F0537, 78F0537D

Figure 7-57. Example of Software Processing for Pulse Width Measurement (1/2)

(a) Example of free-running timer mode

Figure 7-57. Example of Software Processing for Pulse Width Measurement (2/2)

<1> Count operation start flow

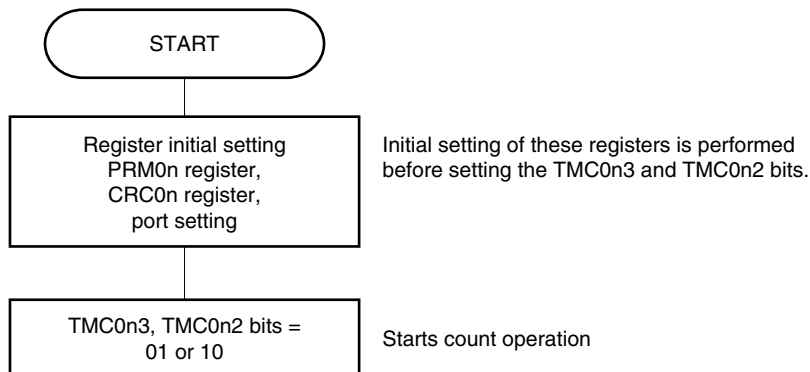

<2> Capture trigger input flow

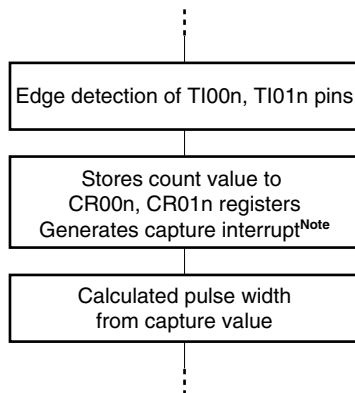

<3> Count operation stop flow

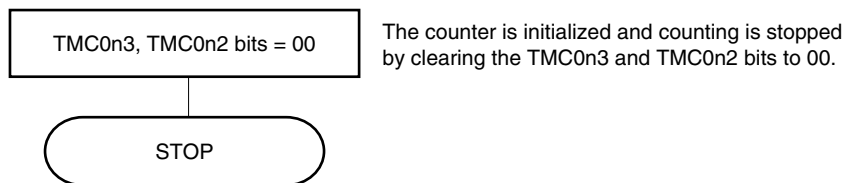

Note The capture interrupt signal (INTTM00n) is not generated when the reverse-phase edge of the TI00n pin input is selected to the valid edge of CR00n.

Remark n = 0: μ PD78F0531, 78F0532, 78F0533
n = 0, 1: μ PD78F0534, 78F0535, 78F0536, 78F0537, 78F0537D

7.5 Special Use of TM0n

7.5.1 Rewriting CR01n during TM0n operation

In principle, rewriting CR00n and CR01n of the 78K0/KE2 when they are used as compare registers is prohibited while TM0n is operating (TMC0n3 and TMC0n2 = other than 00).

However, the value of CR01n can be changed, even while TM0n is operating, using the following procedure if CR01n is used for PPG output and the duty factor is changed (change the value of CR01n immediately after its value matches the value of TM0n. If the value of CR01n is changed immediately before its value matches TM0n, an unexpected operation may be performed).

Procedure for changing value of CR01n

- <1> Disable interrupt INTTM01n (TMMK01n = 1).
- <2> Disable reversal of the timer output when the value of TM0n matches that of CR01n (TOC0n4 = 0).
- <3> Change the value of CR01n.
- <4> Wait for one cycle of the count clock of TM0n.
- <5> Enable reversal of the timer output when the value of TM0n matches that of CR01n (TOC0n4 = 1).
- <6> Clear the interrupt flag of INTTM01n (TMIF01n = 0) to 0.
- <7> Enable interrupt INTTM01n (TMMK01n = 0).

Remark For TMIF01n and TMMK01n, see **CHAPTER 19 INTERRUPT FUNCTIONS**.

7.5.2 Setting LVS0n and LVR0n

(1) Usage of LVS0n and LVR0n

LVS0n and LVR0n are used to set the default value of the TO0n pin output and to invert the timer output without enabling the timer operation (TMC0n3 and TMC0n2 = 00). Clear LVS0n and LVR0n to 00 (default value: low-level output) when software control is unnecessary.

LVS0n	LVR0n	Timer Output Status
0	0	Not changed (low-level output)
0	1	Cleared (low-level output)
1	0	Set (high-level output)
1	1	Setting prohibited

Remark n = 0: μ PD78F0531, 78F0532, 78F0533
n = 0, 1: μ PD78F0534, 78F0535, 78F0536, 78F0537, 78F0537D

(2) Setting LVS0n and LVR0n

Set LVS0n and LVR0n using the following procedure.

Figure 7-58. Example of Flow for Setting LVS0n and LVR0n Bits

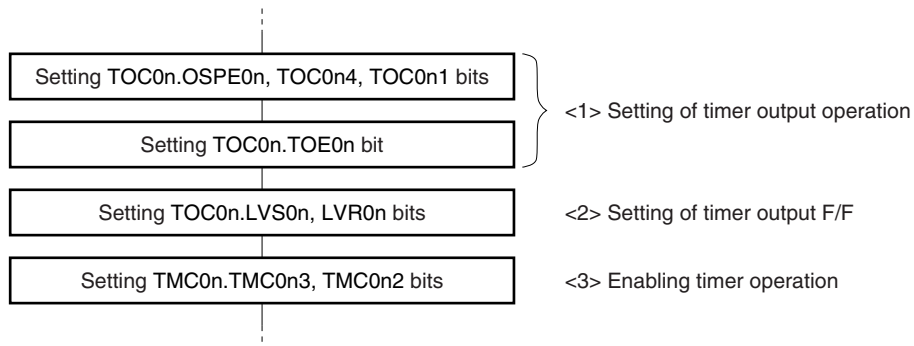

Caution Be sure to set LVS0n and LVR0n following steps <1>, <2>, and <3> above. Step <2> can be performed after <1> and before <3>.

Figure 7-59. Timing Example of LVR0n and LVS0n

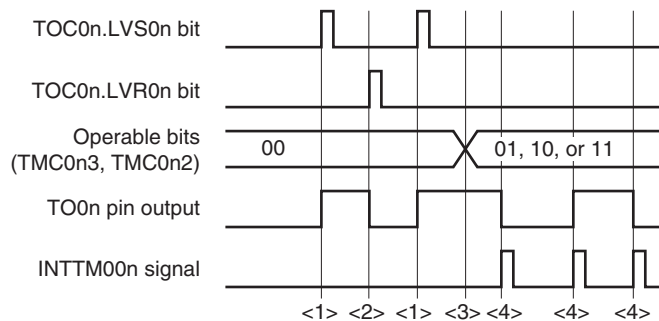

- <1> The TO0n pin output goes high when LVS0n and LVR0n = 10.
- <2> The TO0n pin output goes low when LVS0n and LVR0n = 01 (the pin output remains unchanged from the high level even if LVS0n and LVR0n are cleared to 00).
- <3> The timer starts operating when TMC0n3 and TMC0n2 are set to 01, 10, or 11. Because LVS0n and LVR0n were set to 10 before the operation was started, the TO0n pin output starts from the high level. After the timer starts operating, setting LVS0n and LVR0n is prohibited until TMC0n3 and TMC0n2 = 00 (disabling the timer operation).
- <4> The output level of the TO0n pin is inverted each time an interrupt signal (INTTM00n) is generated.

Remark n = 0: μ PD78F0531, 78F0532, 78F0533
 n = 0, 1: μ PD78F0534, 78F0535, 78F0536, 78F0537, 78F0537D

7.6 Cautions for 16-Bit Timer/Event Counters 00 and 01

(1) Restrictions for each channel of 16-bit timer/event counter 0n

Table 7-5 shows the restrictions for each channel.

Table 7-5. Restrictions for Each Channel of 16-Bit Timer/Event Counter 0n

Operation	Restriction
As interval timer	–
As square wave output	
As external event counter	TOC0n = 00H
As clear & start mode entered by TIO0n pin valid edge input	Using timer output (TO0n) is prohibited when detection of the valid edge of the TIO1n pin is used. TOC0n = 00H
As free-running timer	–
As PPG output	Setting identical values or 0000H to CR00n and CP01n is prohibited.
As one-shot pulse output	–
As pulse width measurement	TOC0n = 00H

(2) Timer start errors

An error of up to one clock may occur in the time required for a match signal to be generated after timer start. This is because counting TM0n is started asynchronously to the count pulse.

Figure 7-60. Start Timing of TM0n Count

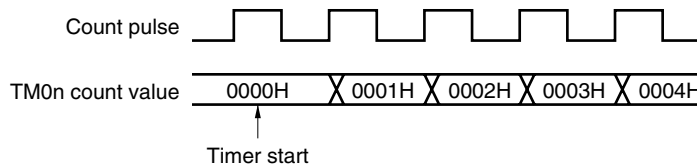

(3) Setting of CR00n and CR01n (clear & start mode entered upon a match between TM0n and CR00n)

Set a value other than 0000H to CR00n and CR01n (TM0n cannot count one pulse when it is used as an external event counter).

Remark n = 0: μ PD78F0531, 78F0532, 78F0533
n = 0, 1: μ PD78F0534, 78F0535, 78F0536, 78F0537, 78F0537D

(4) Timing of holding data by capture register

- (a) When the valid edge is input to the TI00n/TI01n pin and the reverse phase of the TI00n pin is detected while CR00n/CR01n is read, CR01n performs a capture operation but the read value of CR00n/CR01n is not guaranteed. At this time, an interrupt signal (INTTM00n/INTTM01n) is generated when the valid edge of the TI00n/TI01n pin is detected (the interrupt signal is not generated when the reverse-phase edge of the TI00n pin is detected).

When the count value is captured because the valid edge of the TI00n/TI01n pin was detected, read the value of CR00n/CR01n after INTTM00n/INTTM01n is generated.

Figure 7-61. Timing of Holding Data by Capture Register

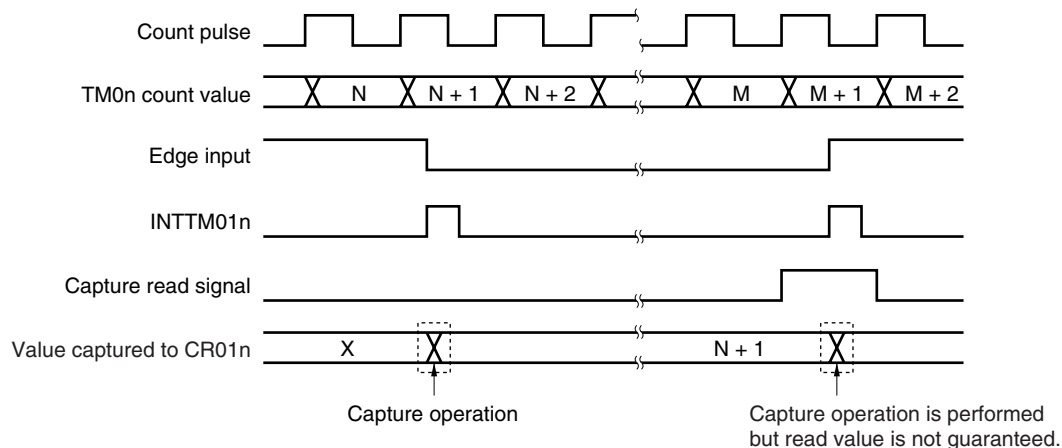

- (b) The values of CR00n and CR01n are not guaranteed after 16-bit timer/event counter 0n stops.

(5) Setting valid edge

Set the valid edge of the TI00n pin while the timer operation is stopped (TMC0n3 and TMC0n2 = 00). Set the valid edge by using ES0n0 and ES0n1.

(6) Re-triggering one-shot pulse

Make sure that the trigger is not generated while an active level is being output in the one-shot pulse output mode. Be sure to input the next trigger after the current active level is output.

Remark n = 0: μ PD78F0531, 78F0532, 78F0533
 n = 0, 1: μ PD78F0534, 78F0535, 78F0536, 78F0537, 78F0537D

(7) Operation of OVF0n flag**(a) Setting OVF0n flag (1)**

The OVF0n flag is set to 1 in the following case, as well as when TM0n overflows.

Select the clear & start mode entered upon a match between TM0n and CR00n.

↓

Set CR00n to FFFFH.

↓

When TM0n matches CR00n and TM0n is cleared from FFFFH to 0000H

Figure 7-62. Operation Timing of OVF0n Flag

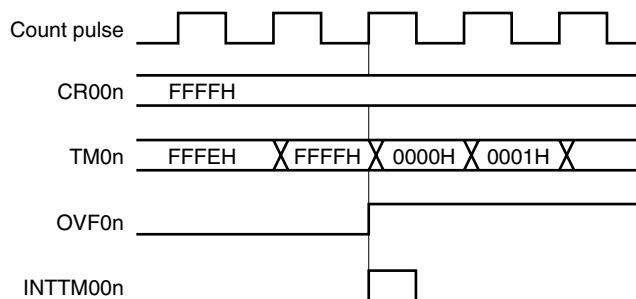
**(b) Clearing OVF0n flag**

Even if the OVF0n flag is cleared to 0 after TM0n overflows and before the next count clock is counted (before the value of TM0n becomes 0001H), it is set to 1 again and clearing is invalid.

(8) One-shot pulse output

One-shot pulse output operates correctly in the free-running timer mode or the clear & start mode entered by the TI00n pin valid edge. The one-shot pulse cannot be output in the clear & start mode entered upon a match between TM0n and CR00n.

Remark n = 0: μ PD78F0531, 78F0532, 78F0533

n = 0, 1: μ PD78F0534, 78F0535, 78F0536, 78F0537, 78F0537D

(9) Capture operation**(a) When valid edge of TI00n is specified as count clock**

When the valid edge of TI00n is specified as the count clock, the capture register for which TI00n is specified as a trigger does not operate correctly.

(b) Pulse width to accurately capture value by signals input to TI01n and TI00n pins

To accurately capture the count value, the pulse input to the TI00n and TI01n pins as a capture trigger must be wider than two count clocks selected by PRM0n (see **Figure 7-9**).

(c) Generation of interrupt signal

The capture operation is performed at the falling edge of the count clock but the interrupt signals (INTTM00n and INTTM01n) are generated at the rising edge of the next count clock (see **Figure 7-9**).

(d) Note when CRC0n1 (bit 1 of capture/compare control register 0n (CRC0n)) is set to 1

When the count value of the TM0n register is captured to the CR00n register in the phase reverse to the signal input to the TI00n pin, the interrupt signal (INTTM00n) is not generated after the count value is captured. If the valid edge is detected on the TI01n pin during this operation, the capture operation is not performed but the INTTM00n signal is generated as an external interrupt signal. Mask the INTTM00n signal when the external interrupt is not used.

(10) Edge detection**(a) Specifying valid edge after reset**

If the operation of the 16-bit timer/event counter 0n is enabled after reset and while the TI00n or TI01n pin is at high level and when the rising edge or both the edges are specified as the valid edge of the TI00n or TI01n pin, then the high level of the TI00n or TI01n pin is detected as the rising edge. Note this when the TI00n or TI01n pin is pulled up. However, the rising edge is not detected when the operation is once stopped and then enabled again.

(b) Sampling clock for eliminating noise

The sampling clock for eliminating noise differs depending on whether the valid edge of TI00n is used as the count clock or capture trigger. In the former case, the sampling clock is fixed to f_{PRS} . In the latter, the count clock selected by PRM0n is used for sampling.

When the signal input to the TI00n pin is sampled and the valid level is detected two times in a row, the valid edge is detected. Therefore, noise having a short pulse width can be eliminated (see **Figure 7-9**).

(11) Timer operation

The signal input to the TI00n/TI01n pin is not acknowledged while the timer is stopped, regardless of the operation mode of the CPU.

Remarks 1. f_{PRS} : Peripheral hardware clock frequency

2. $n = 0$: μ PD78F0531, 78F0532, 78F0533

$n = 0, 1$: μ PD78F0534, 78F0535, 78F0536, 78F0537, 78F0537D

CHAPTER 8 8-BIT TIMER/EVENT COUNTERS 50 AND 51

8.1 Functions of 8-Bit Timer/Event Counters 50 and 51

8-bit timer/event counters 50 and 51 have the following functions.

- Interval timer
- External event counter
- Square-wave output
- PWM output

8.2 Configuration of 8-Bit Timer/Event Counters 50 and 51

8-bit timer/event counters 50 and 51 include the following hardware.

Table 8-1. Configuration of 8-Bit Timer/Event Counters 50 and 51

Item	Configuration
Timer register	8-bit timer counter 5n (TM5n)
Register	8-bit timer compare register 5n (CR5n)
Timer input	TI5n
Timer output	TO5n
Control registers	Timer clock selection register 5n (TCL5n) 8-bit timer mode control register 5n (TMC5n) Port mode register 1 (PM1) or port mode register 3 (PM3) Port register 1 (P1) or port register 3 (P3)

Figures 8-1 and 8-2 show the block diagrams of 8-bit timer/event counters 50 and 51.

Figure 8-1. Block Diagram of 8-Bit Timer/Event Counter 50

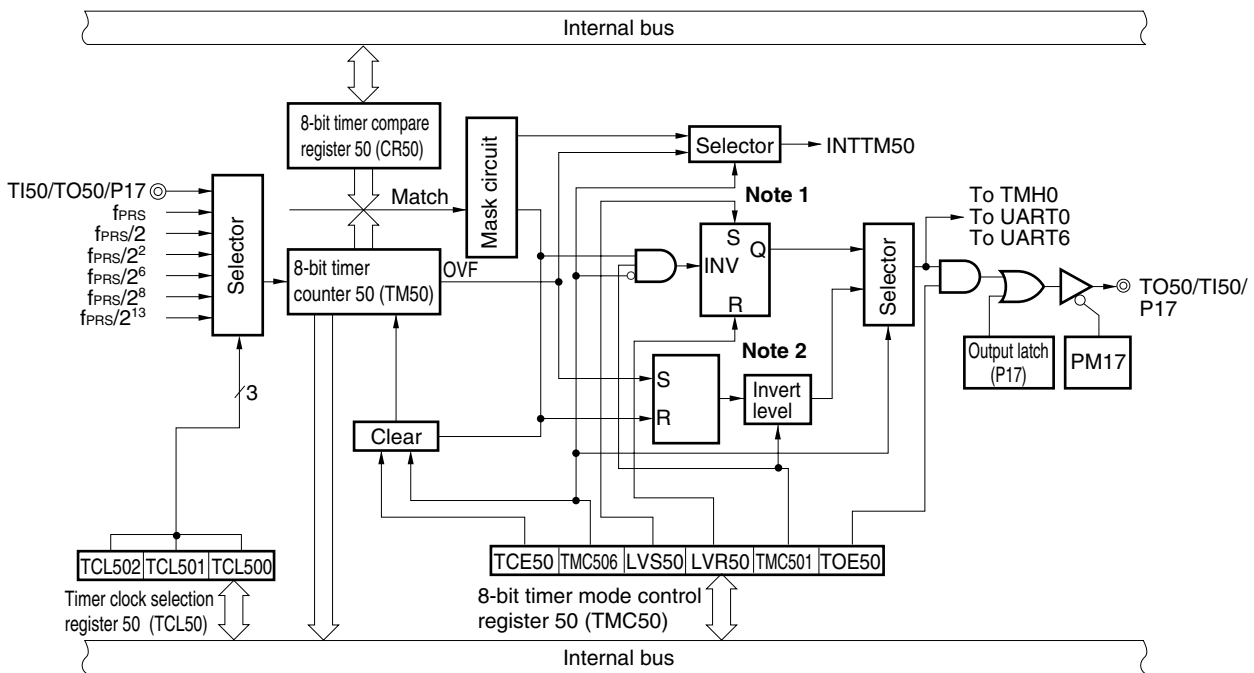
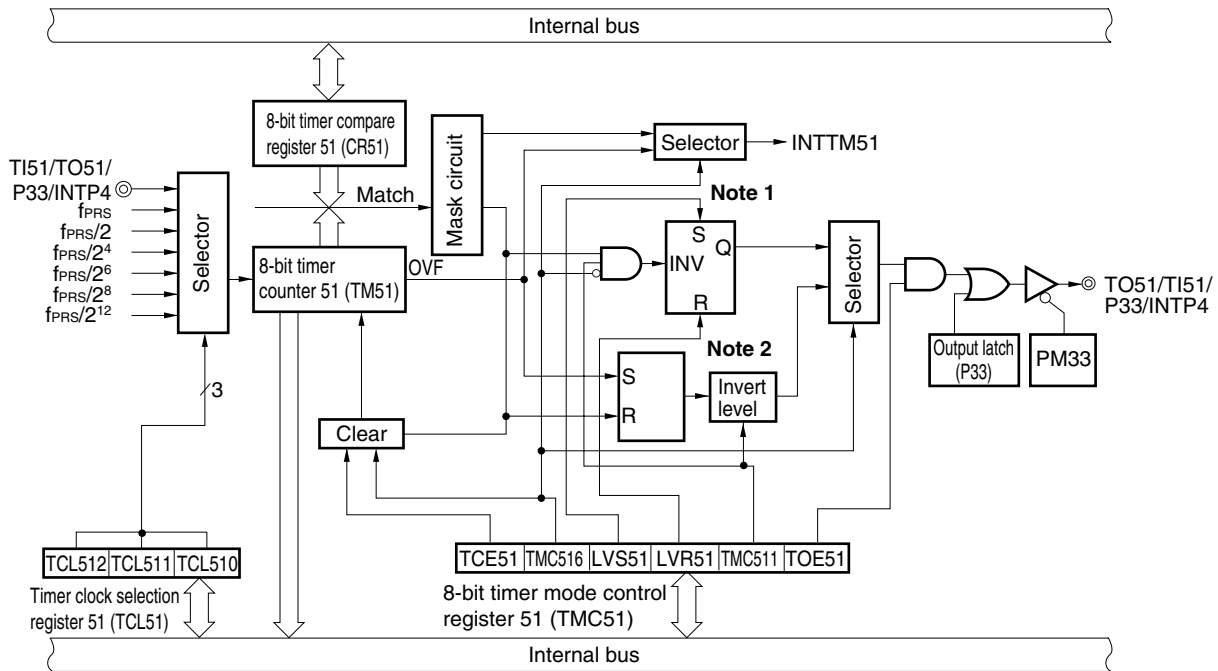

Figure 8-2. Block Diagram of 8-Bit Timer/Event Counter 51



- Notes**
1. Timer output F/F
 2. PWM output F/F

(1) 8-bit timer counter 5n (TM5n)

TM5n is an 8-bit register that counts the count pulses and is read-only.

The counter is incremented in synchronization with the rising edge of the count clock.

Figure 8-3. Format of 8-Bit Timer Counter 5n (TM5n)

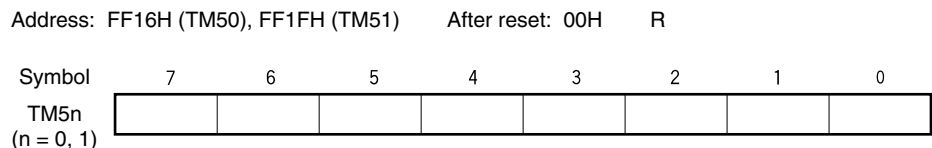

In the following situations, the count value is cleared to 00H.

- <1> Reset signal generation
- <2> When TCE5n is cleared
- <3> When TM5n and CR5n match in the mode in which clear & start occurs upon a match of the TM5n and CR5n.

(2) 8-bit timer compare register 5n (CR5n)

CR5n can be read and written by an 8-bit memory manipulation instruction.

Except in PWM mode, the value set in CR5n is constantly compared with the 8-bit timer counter 5n (TM5n) count value, and an interrupt request (INTTM5n) is generated if they match.

★ In the PWM mode, the TO5n pin becomes inactive when the values of TM5n and CR5n match, but no interrupt is generated.

The value of CR5n can be set within 00H to FFH.

Reset signal generation sets CR5n to 00H.

Figure 8-4. Format of 8-Bit Timer Compare Register 5n (CR5n)

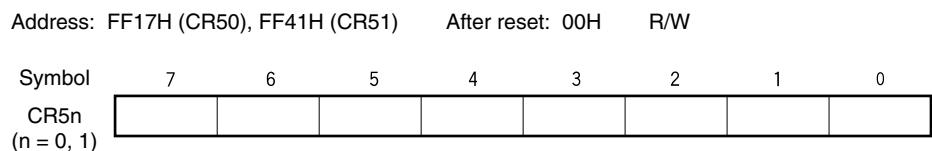

- Cautions**
1. In the mode in which clear & start occurs on a match of TM5n and CR5n (TMC5n6 = 0), do not write other values to CR5n during operation.
 2. In PWM mode, make the CR5n rewrite period 3 count clocks of the count clock (clock selected by TCL5n) or more.

Remark n = 0, 1

8.3 Registers Controlling 8-Bit Timer/Event Counters 50 and 51

The following four registers are used to control 8-bit timer/event counters 50 and 51.

- Timer clock selection register 5n (TCL5n)
- 8-bit timer mode control register 5n (TMC5n)
- Port mode register 1 (PM1) or port mode register 3 (PM3)
- Port register 1 (P1) or port register 3 (P3)

(1) Timer clock selection register 5n (TCL5n)

This register sets the count clock of 8-bit timer/event counter 5n and the valid edge of the TI5n pin input.

TCL5n can be set by a 1-bit or 8-bit memory manipulation instruction.

Reset signal generation sets TCL5n to 00H.

Remark n = 0, 1

Figure 8-5. Format of Timer Clock Selection Register 50 (TCL50)

Address: FF6AH After reset: 00H R/W

Symbol	7	6	5	4	3	2	1	0
TCL50	0	0	0	0	0	TCL502	TCL501	TCL500

TCL502	TCL501	TCL500	Count clock selection				
			$f_{PRS} =$ 2 MHz	$f_{PRS} =$ 5 MHz	$f_{PRS} =$ 10 MHz	$f_{PRS} =$ 20 MHz	
0	0	0	TI50 pin falling edge				
0	0	1	TI50 pin rising edge				
0	1	0	f_{PRS}	2 MHz	5 MHz	10 MHz	20 MHz
0	1	1	$f_{PRS}/2$	1 MHz	2.5 MHz	5 MHz	10 MHz
1	0	0	$f_{PRS}/2^2$	500 kHz	1.25 MHz	2.5 MHz	5 MHz
1	0	1	$f_{PRS}/2^6$	31.25 kHz	78.13 kHz	156.25 kHz	312.5 kHz
1	1	0	$f_{PRS}/2^8$	7.81 kHz	19.53 kHz	39.06 kHz	78.13 kHz
1	1	1	$f_{PRS}/2^{13}$	0.24 kHz	0.61 kHz	1.22 kHz	2.44 kHz

- Cautions**
1. When rewriting TCL50 to other data, stop the timer operation beforehand.
 2. Be sure to clear bits 3 to 7 to 0.

Remark f_{PRS} : Peripheral hardware clock frequency

Figure 8-6. Format of Timer Clock Selection Register 51 (TCL51)

Address: FF8CH After reset: 00H R/W

Symbol	7	6	5	4	3	2	1	0
TCL51	0	0	0	0	0	TCL512	TCL511	TCL510

TCL512	TCL511	TCL510	Count clock selection				
			$f_{PRS} =$ 2 MHz	$f_{PRS} =$ 5 MHz	$f_{PRS} =$ 10 MHz	$f_{PRS} =$ 20 MHz	
0	0	0	TI51 pin falling edge				
0	0	1	TI51 pin rising edge				
0	1	0	f_{PRS}	2 MHz	5 MHz	10 MHz	20 MHz
0	1	1	$f_{PRS}/2$	1 MHz	2.5 MHz	5 MHz	10 MHz
1	0	0	$f_{PRS}/2^4$	125 kHz	312.5 kHz	625 kHz	1.25 MHz
1	0	1	$f_{PRS}/2^6$	31.25 kHz	78.13 kHz	156.25 kHz	312.5 kHz
1	1	0	$f_{PRS}/2^8$	7.81 kHz	19.53 kHz	39.06 kHz	78.13 kHz
1	1	1	$f_{PRS}/2^{12}$	0.49 kHz	1.22 kHz	2.44 kHz	4.88 kHz

- Cautions**
1. When rewriting TCL51 to other data, stop the timer operation beforehand.
 2. Be sure to clear bits 3 to 7 to 0.

Remark f_{PRS} : Peripheral hardware clock frequency

(2) 8-bit timer mode control register 5n (TMC5n)

TMC5n is a register that performs the following five types of settings.

- <1> 8-bit timer counter 5n (TM5n) count operation control
- <2> 8-bit timer counter 5n (TM5n) operating mode selection
- <3> Timer output F/F (flip flop) status setting
- <4> Active level selection in timer F/F control or PWM (free-running) mode.
- <5> Timer output control

TMC5n can be set by a 1-bit or 8-bit memory manipulation instruction.

Reset signal generation sets this register to 00H.

Remark n = 0, 1

Figure 8-7. Format of 8-Bit Timer Mode Control Register 50 (TMC50)

Address: FF6BH After reset: 00H R/W^{Note}

Symbol	<7>	6	5	4	<3>	<2>	1	<0>															
TMC50	TCE50	TMC506	0	0	LVS50	LVR50	TMC501	TOE50															
	<table border="1"> <thead> <tr> <th>TCE50</th> <th>TM50 count operation control</th> </tr> </thead> <tbody> <tr> <td>0</td> <td>After clearing to 0, count operation disabled (counter stopped)</td> </tr> <tr> <td>1</td> <td>Count operation start</td> </tr> </tbody> </table>								TCE50	TM50 count operation control	0	After clearing to 0, count operation disabled (counter stopped)	1	Count operation start									
TCE50	TM50 count operation control																						
0	After clearing to 0, count operation disabled (counter stopped)																						
1	Count operation start																						
	<table border="1"> <thead> <tr> <th>TMC506</th> <th>TM50 operating mode selection</th> </tr> </thead> <tbody> <tr> <td>0</td> <td>Mode in which clear & start occurs on a match between TM50 and CR50</td> </tr> <tr> <td>1</td> <td>PWM (free-running) mode</td> </tr> </tbody> </table>								TMC506	TM50 operating mode selection	0	Mode in which clear & start occurs on a match between TM50 and CR50	1	PWM (free-running) mode									
TMC506	TM50 operating mode selection																						
0	Mode in which clear & start occurs on a match between TM50 and CR50																						
1	PWM (free-running) mode																						
	<table border="1"> <thead> <tr> <th>LVS50</th> <th>LVR50</th> <th>Timer output F/F status setting</th> </tr> </thead> <tbody> <tr> <td>0</td> <td>0</td> <td>No change</td> </tr> <tr> <td>0</td> <td>1</td> <td>Timer output F/F clear (0) (default output value of TO50 pin: low level)</td> </tr> <tr> <td>1</td> <td>0</td> <td>Timer output F/F set (1) (default output value of TO50 pin: high level)</td> </tr> <tr> <td>1</td> <td>1</td> <td>Setting prohibited</td> </tr> </tbody> </table>								LVS50	LVR50	Timer output F/F status setting	0	0	No change	0	1	Timer output F/F clear (0) (default output value of TO50 pin: low level)	1	0	Timer output F/F set (1) (default output value of TO50 pin: high level)	1	1	Setting prohibited
LVS50	LVR50	Timer output F/F status setting																					
0	0	No change																					
0	1	Timer output F/F clear (0) (default output value of TO50 pin: low level)																					
1	0	Timer output F/F set (1) (default output value of TO50 pin: high level)																					
1	1	Setting prohibited																					
	<table border="1"> <thead> <tr> <th rowspan="2">TMC501</th> <th>In other modes (TMC506 = 0)</th> <th>In PWM mode (TMC506 = 1)</th> </tr> <tr> <th>Timer F/F control</th> <th>Active level selection</th> </tr> </thead> <tbody> <tr> <td>0</td> <td>Inversion operation disabled</td> <td>Active-high</td> </tr> <tr> <td>1</td> <td>Inversion operation enabled</td> <td>Active-low</td> </tr> </tbody> </table>								TMC501	In other modes (TMC506 = 0)	In PWM mode (TMC506 = 1)	Timer F/F control	Active level selection	0	Inversion operation disabled	Active-high	1	Inversion operation enabled	Active-low				
TMC501	In other modes (TMC506 = 0)	In PWM mode (TMC506 = 1)																					
	Timer F/F control	Active level selection																					
0	Inversion operation disabled	Active-high																					
1	Inversion operation enabled	Active-low																					
	<table border="1"> <thead> <tr> <th>TOE50</th> <th>Timer output control</th> </tr> </thead> <tbody> <tr> <td>0</td> <td>Output disabled (TM50 output is low level)</td> </tr> <tr> <td>1</td> <td>Output enabled</td> </tr> </tbody> </table>								TOE50	Timer output control	0	Output disabled (TM50 output is low level)	1	Output enabled									
TOE50	Timer output control																						
0	Output disabled (TM50 output is low level)																						
1	Output enabled																						

Note Bits 2 and 3 are write-only.

(**Cautions** and **Remarks** are listed on the next page.)

Figure 8-8. Format of 8-Bit Timer Mode Control Register 51 (TMC51)

Address: FF43H After reset: 00H R/W^{Note}

Symbol	<7>	6	5	4	<3>	<2>	1	<0>
TMC51	TCE51	TMC516	0	0	LVS51	LVR51	TMC511	TOE51
TCE51	TM51 count operation control							
0	After clearing to 0, count operation disabled (counter stopped)							
1	Count operation start							
TMC516	TM51 operating mode selection							
0	Mode in which clear & start occurs on a match between TM51 and CR51							
1	PWM (free-running) mode							
LVS51	LVR51	Timer output F/F status setting						
0	0	No change						
0	1	Timer output F/F clear (0) (default output value of TO51 pin: low)						
1	0	Timer output F/F set (1) (default output value of TO51 pin: high)						
1	1	Setting prohibited						
TMC511	In other modes (TMC516 = 0)				In PWM mode (TMC516 = 1)			
	Timer F/F control				Active level selection			
0	Inversion operation disabled				Active-high			
1	Inversion operation enabled				Active-low			
TOE51	Timer output control							
0	Output disabled (TM51 output is low level)							
1	Output enabled							

Note Bits 2 and 3 are write-only.

- Cautions**
1. The settings of LVS5n and LVR5n are valid in other than PWM mode.
 2. Perform <1> to <4> below in the following order, not at the same time.
 - <1> Set TMC5n1, TMC5n6: Operation mode setting
 - <2> Set TOE5n to enable output: Timer output enable
 - <3> Set LVS5n, LVR5n (see Caution 1): Timer F/F setting
 - <4> Set TCE5n
 3. Stop operation before rewriting TMC5n6.

- Remarks**
1. In PWM mode, PWM output is made inactive by clearing TCE5n to 0.
 2. If LVS5n and LVR5n are read, the value is 0.
 3. The values of the TMC5n6, LVS5n, LVR5n, TMC5n1, and TOE5n bits are reflected at the TO5n pin regardless of the value of TCE5n.
 4. n = 0, 1

(3) Port mode registers 1 and 3 (PM1, PM3)

These registers set port 1 and 3 input/output in 1-bit units.

When using the P17/TO50/TI50 and P33/TO51/TI51/INTP4 pins for timer output, clear PM17 and PM33 and the output latches of P17 and P33 to 0.

When using the P17/TO50/TI50 and P33/TO51/TI51/INTP4 pins for timer input, set PM17 and PM33 to 1. The output latches of P17 and P33 at this time may be 0 or 1.

PM1 and PM3 can be set by a 1-bit or 8-bit memory manipulation instruction.

Reset signal generation sets these registers to FFH.

Figure 8-9. Format of Port Mode Register 1 (PM1)

Address: FF21H After reset: FFH R/W

Symbol	7	6	5	4	3	2	1	0
PM1	PM17	PM16	PM15	PM14	PM13	PM12	PM11	PM10

PM1n	P1n pin I/O mode selection (n = 0 to 7)
0	Output mode (output buffer on)
1	Input mode (output buffer off)

Figure 8-10. Format of Port Mode Register 3 (PM3)

Address: FF23H After reset: FFH R/W

Symbol	7	6	5	4	3	2	1	0
PM3	1	1	1	1	PM33	PM32	PM31	PM30

PM3n	P3n pin I/O mode selection (n = 0 to 3)
0	Output mode (output buffer on)
1	Input mode (output buffer off)

8.4 Operations of 8-Bit Timer/Event Counters 50 and 51

8.4.1 Operation as interval timer

8-bit timer/event counter 5n operates as an interval timer that generates interrupt requests repeatedly at intervals of the count value preset to 8-bit timer compare register 5n (CR5n).

When the count value of 8-bit timer counter 5n (TM5n) matches the value set to CR5n, counting continues with the TM5n value cleared to 0 and an interrupt request signal (INTTM5n) is generated.

The count clock of TM5n can be selected with bits 0 to 2 (TCL5n0 to TCL5n2) of timer clock selection register 5n (TCL5n).

Setting

<1> Set the registers.

- TCL5n: Select the count clock.
- CR5n: Compare value
- TMC5n: Stop the count operation, select the mode in which clear & start occurs on a match of TM5n and CR5n.

(TMC5n = 0000xxx0B x = Don't care)

<2> After TCE5n = 1 is set, the count operation starts.

<3> If the values of TM5n and CR5n match, INTTM5n is generated (TM5n is cleared to 00H).

<4> INTTM5n is generated repeatedly at the same interval.

Set TCE5n to 0 to stop the count operation.

Caution Do not write other values to CR5n during operation.

Remarks 1. For how to enable the INTTM5n signal interrupt, see **CHAPTER 19 INTERRUPT FUNCTIONS**.

2. n = 0, 1

Figure 8-11. Interval Timer Operation Timing (1/2)

(a) Basic operation

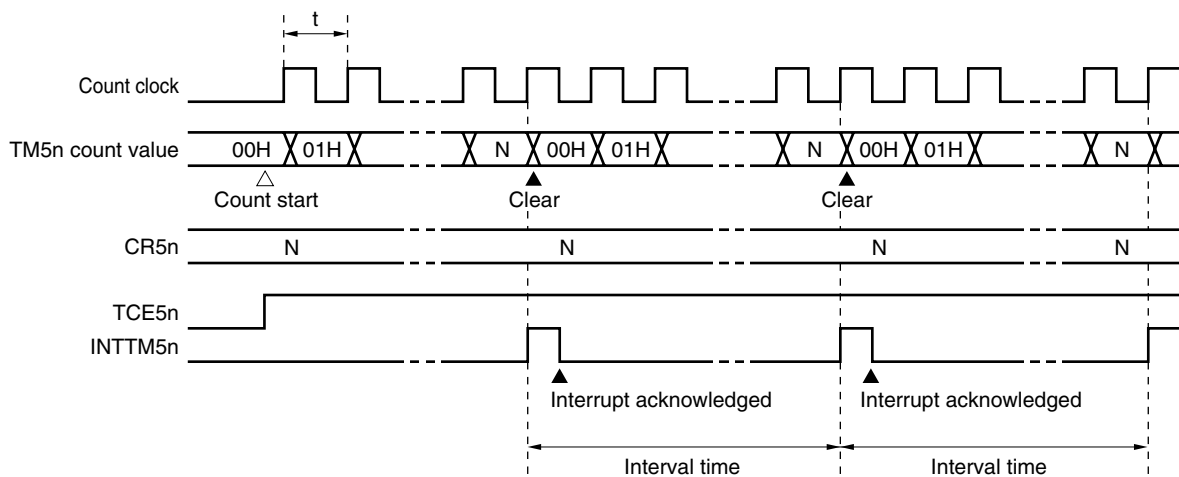

Remark Interval time = $(N + 1) \times t$

N = 01H to FFH

n = 0, 1

Figure 8-11. Interval Timer Operation Timing (2/2)

(b) When CR5n = 00H

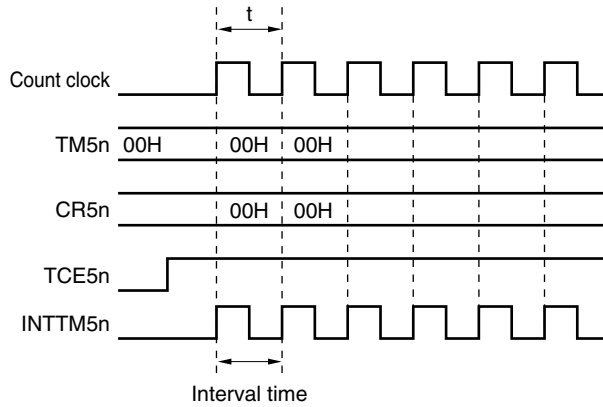

(c) When CR5n = FFH

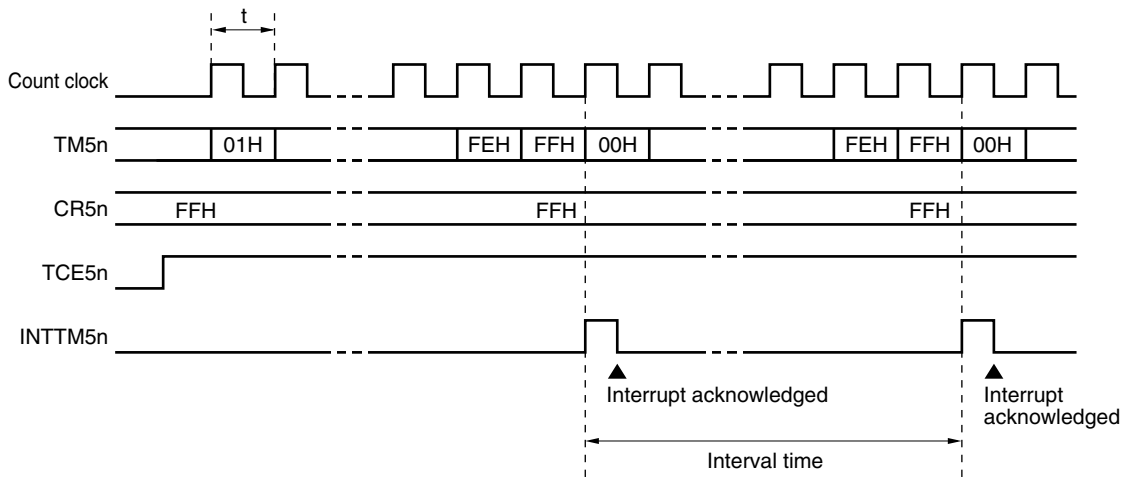

Remark $n = 0, 1$

8.4.2 Operation as external event counter

The external event counter counts the number of external clock pulses to be input to the TI5n pin by 8-bit timer counter 5n (TM5n).

TM5n is incremented each time the valid edge specified by timer clock selection register 5n (TCL5n) is input. Either the rising or falling edge can be selected.

When the TM5n count value matches the value of 8-bit timer compare register 5n (CR5n), TM5n is cleared to 0 and an interrupt request signal (INTTM5n) is generated.

Whenever the TM5n value matches the value of CR5n, INTTM5n is generated.

Setting

<1> Set each register.

- Set the port mode register (PM17 or PM33)^{Note} to 1.
- TCL5n: Select TI5n pin input edge.
 TI5n pin falling edge → TCL5n = 00H
 TI5n pin rising edge → TCL5n = 01H
- CR5n: Compare value
- TMC5n: Stop the count operation, select the mode in which clear & start occurs on match of TM5n and CR5n, disable the timer F/F inversion operation, disable timer output.
 (TMC5n = 0000xx00B x = Don't care)

<2> When TCE5n = 1 is set, the number of pulses input from the TI5n pin is counted.

<3> When the values of TM5n and CR5n match, INTTM5n is generated (TM5n is cleared to 00H).

<4> After these settings, INTTM5n is generated each time the values of TM5n and CR5n match.

Note 8-bit timer/event counter 50: PM17
 8-bit timer/event counter 51: PM33

Remark For how to enable the INTTM5n signal interrupt, see **CHAPTER 19 INTERRUPT FUNCTIONS**.

Figure 8-12. External Event Counter Operation Timing (with Rising Edge Specified)

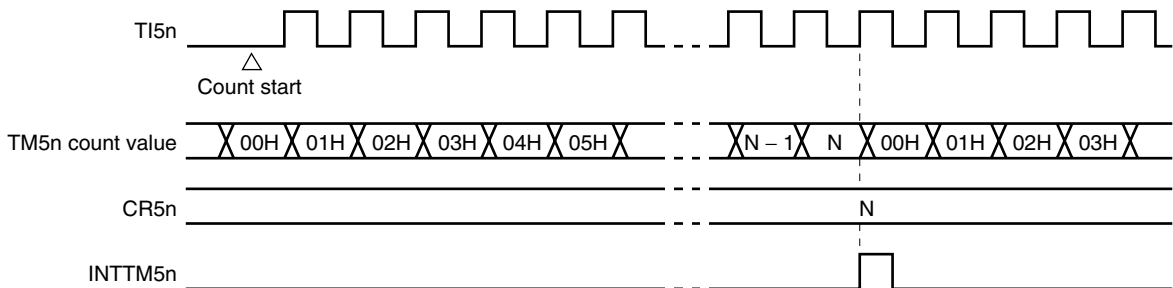

Remark N = 00H to FFH
 n = 0, 1

8.4.3 Square-wave output operation

A square wave with any selected frequency is output at intervals determined by the value preset to 8-bit timer compare register 5n (CR5n).

The TO5n pin output status is inverted at intervals determined by the count value preset to CR5n by setting bit 0 (TOE5n) of 8-bit timer mode control register 5n (TMC5n) to 1. This enables a square wave with any selected frequency to be output (duty = 50%).

Setting

<1> Set each register.

- Clear the port output latch (P17 or P33)^{Note} and port mode register (PM17 or PM33)^{Note} to 0.
- TCL5n: Select the count clock.
- CR5n: Compare value
- TMC5n: Stop the count operation, select the mode in which clear & start occurs on a match of TM5n and CR5n.

LVS5n	LVR5n	Timer Output F/F Status Setting
1	0	Timer output F/F clear (0) (default output value of TO50 pin: low level)
0	1	Timer output F/F set (1) (default output value of TO5n pin: high level)

Timer output enabled

(TMC5n = 00001011B or 00000111B)

<2> After TCE5n = 1 is set, the count operation starts.

<3> The timer output F/F is inverted by a match of TM5n and CR5n. After INTTM5n is generated, TM5n is cleared to 00H.

<4> After these settings, the timer output F/F is inverted at the same interval and a square wave is output from TO5n.

The frequency is as follows.

- Frequency = $1/2t(N + 1)$
(N: 00H to FFH)

Note 8-bit timer/event counter 50: P17, PM17

8-bit timer/event counter 51: P33, PM33

Caution Do not write other values to CR5n during operation.

Remarks 1. For how to enable the INTTM5n signal interrupt, see **CHAPTER 19 INTERRUPT FUNCTIONS**.

2. n = 0, 1

Figure 8-13. Square-Wave Output Operation Timing

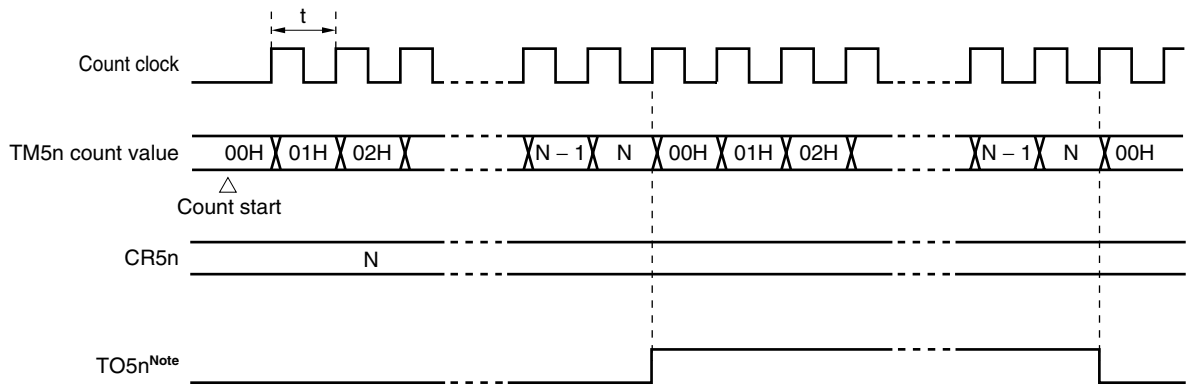

Note The initial value of TO5n output can be set by bits 2 and 3 (LVR5n, LVS5n) of 8-bit timer mode control register 5n (TMC5n).

8.4.4 PWM output operation

8-bit timer/event counter 5n operates as a PWM output when bit 6 (TMC5n6) of 8-bit timer mode control register 5n (TMC5n) is set to 1.

The duty pulse determined by the value set to 8-bit timer compare register 5n (CR5n) is output from TO5n.

Set the active level width of the PWM pulse to CR5n; the active level can be selected with bit 1 (TMC5n1) of TMC5n.

The count clock can be selected with bits 0 to 2 (TCL5n0 to TCL5n2) of timer clock selection register 5n (TCL5n).

PWM output can be enabled/disabled with bit 0 (TOE5n) of TMC5n.

Caution In PWM mode, make the CR5n rewrite period 3 count clocks of the count clock (clock selected by TCL5n) or more.

Remark n = 0, 1

(1) PWM output basic operation**Setting**

<1> Set each register.

- Clear the port output latch (P17 or P33)^{Note} and port mode register (PM17 or PM33)^{Note} to 0.
- TCL5n: Select the count clock.
- CR5n: Compare value
- TMC5n: Stop the count operation, select PWM mode.

The timer output F/F is not changed.

TMC5n1	Active Level Selection
0	Active-high
1	Active-low

Timer output enabled

(TMC5n = 01000001B or 01000011B)

<2> The count operation starts when TCE5n = 1.
Clear TCE5n to 0 to stop the count operation.

Note 8-bit timer/event counter 50: P17, PM17
8-bit timer/event counter 51: P33, PM33

PWM output operation

- <1> PWM output (output from TO5n) outputs an inactive level until an overflow occurs.
- <2> When an overflow occurs, the active level is output. The active level is output until CR5n matches the count value of 8-bit timer counter 5n (TM5n).
- <3> After the CR5n matches the count value, the inactive level is output until an overflow occurs again.
- <4> Operations <2> and <3> are repeated until the count operation stops.
- <5> When the count operation is stopped with TCE5n = 0, PWM output becomes inactive.

For details of timing, see **Figures 8-14** and **8-15**.

The cycle, active-level width, and duty are as follows.

- Cycle = $2^8 t$
- Active-level width = Nt
- Duty = $N/2^8$
(N = 00H to FFH)

Remark n = 0, 1

Figure 8-14. PWM Output Operation Timing

(a) Basic operation (active level = H)

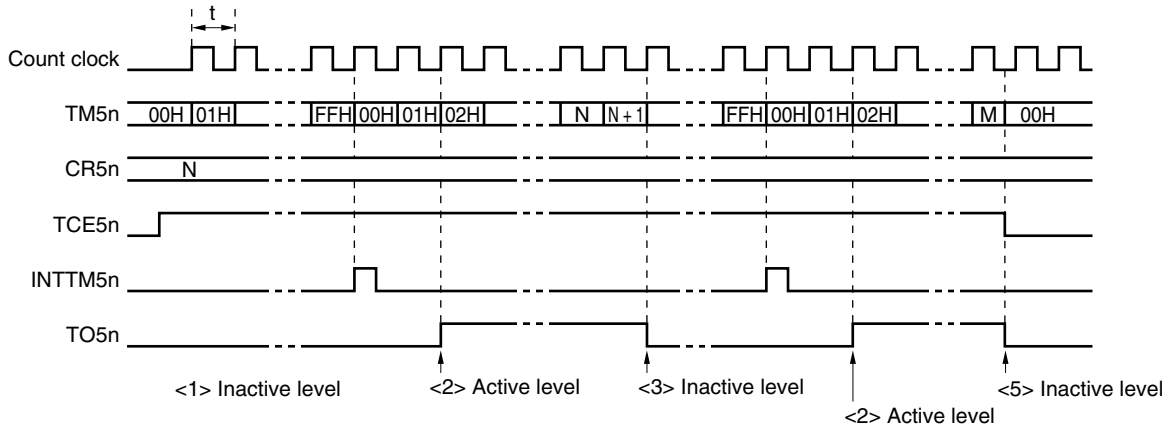

(b) CR5n = 00H

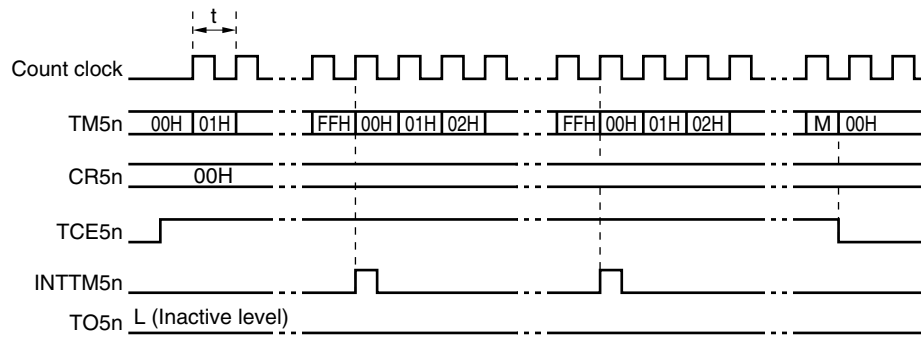

(c) CR5n = FFH

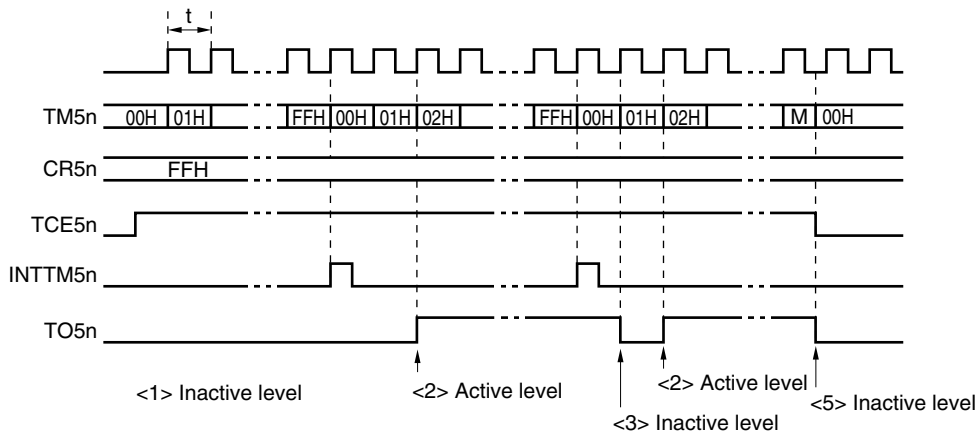

Remarks 1. <1> to <3> and <5> in Figure 8-14 (a) correspond to <1> to <3> and <5> in PWM output operation in **8.4.4 (1) PWM output basic operation.**

2. n = 0, 1

(2) Operation with CR5n changed

Figure 8-15. Timing of Operation with CR5n Changed

- (a) CR5n value is changed from N to M before clock rising edge of FFH
 → Value is transferred to CR5n at overflow immediately after change.

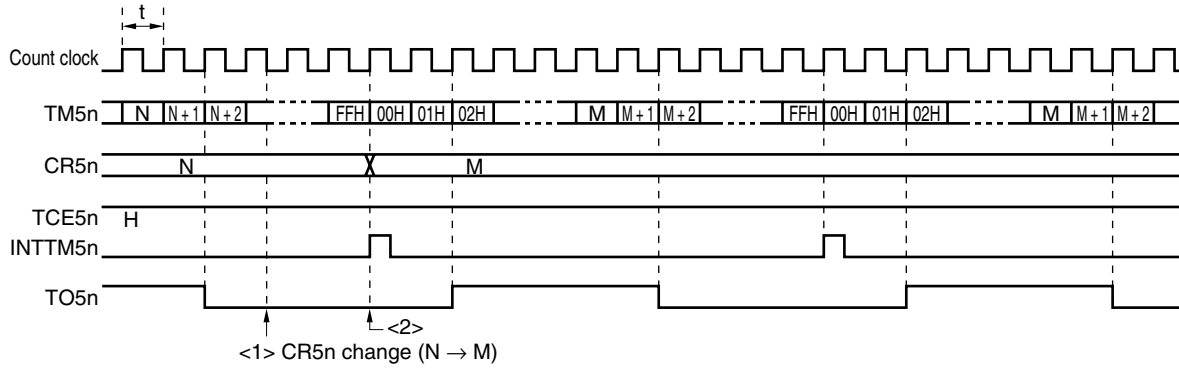

- (b) CR5n value is changed from N to M after clock rising edge of FFH
 → Value is transferred to CR5n at second overflow.

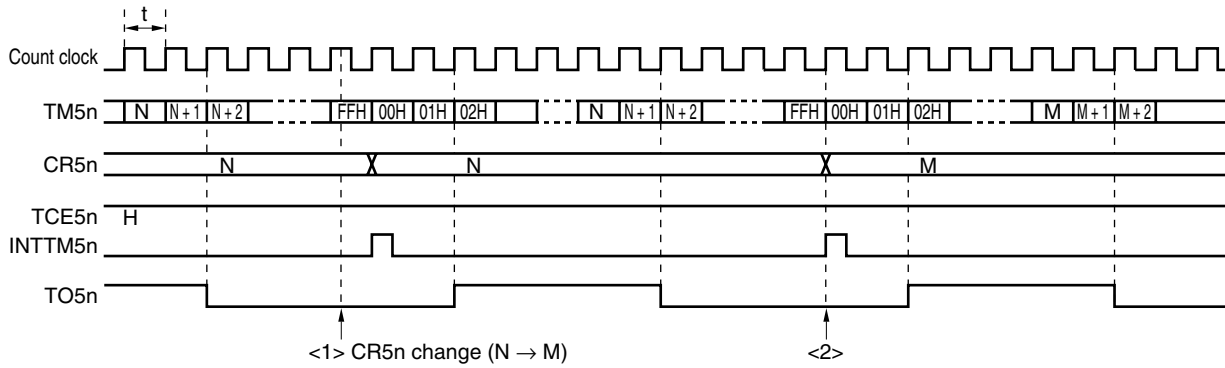

Caution When reading from CR5n between <1> and <2> in Figure 8-15, the value read differs from the actual value (read value: M, actual value of CR5n: N).

8.5 Cautions for 8-Bit Timer/Event Counters 50 and 51

(1) Timer start error

An error of up to one clock may occur in the time required for a match signal to be generated after timer start. This is because 8-bit timer counters 50 and 51 (TM50, TM51) are started asynchronously to the count clock.

Figure 8-16. 8-Bit Timer Counter 5n Start Timing

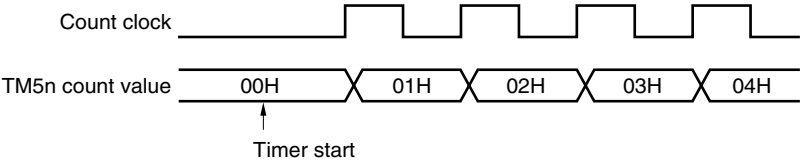

Remark n = 0, 1

CHAPTER 9 8-BIT TIMERS H0 AND H1

9.1 Functions of 8-Bit Timers H0 and H1

8-bit timers H0 and H1 have the following functions.

- Interval timer
- Square-wave output
- PWM output
- Carrier generator (8-bit timer H1 only)

9.2 Configuration of 8-Bit Timers H0 and H1

8-bit timers H0 and H1 include the following hardware.

Table 9-1. Configuration of 8-Bit Timers H0 and H1

Item	Configuration
Timer register	8-bit timer counter Hn
Registers	8-bit timer H compare register 0n (CMP0n) 8-bit timer H compare register 1n (CMP1n)
Timer output	TOHn, output controller
Control registers	8-bit timer H mode register n (TMHMDn) 8-bit timer H carrier control register 1 (TMCYC1) ^{Note} Port mode register 1 (PM1) Port register 1 (P1)

Note 8-bit timer H1 only

Remark n = 0, 1

Figures 9-1 and 9-2 show the block diagrams.

Figure 9-1. Block Diagram of 8-Bit Timer H0

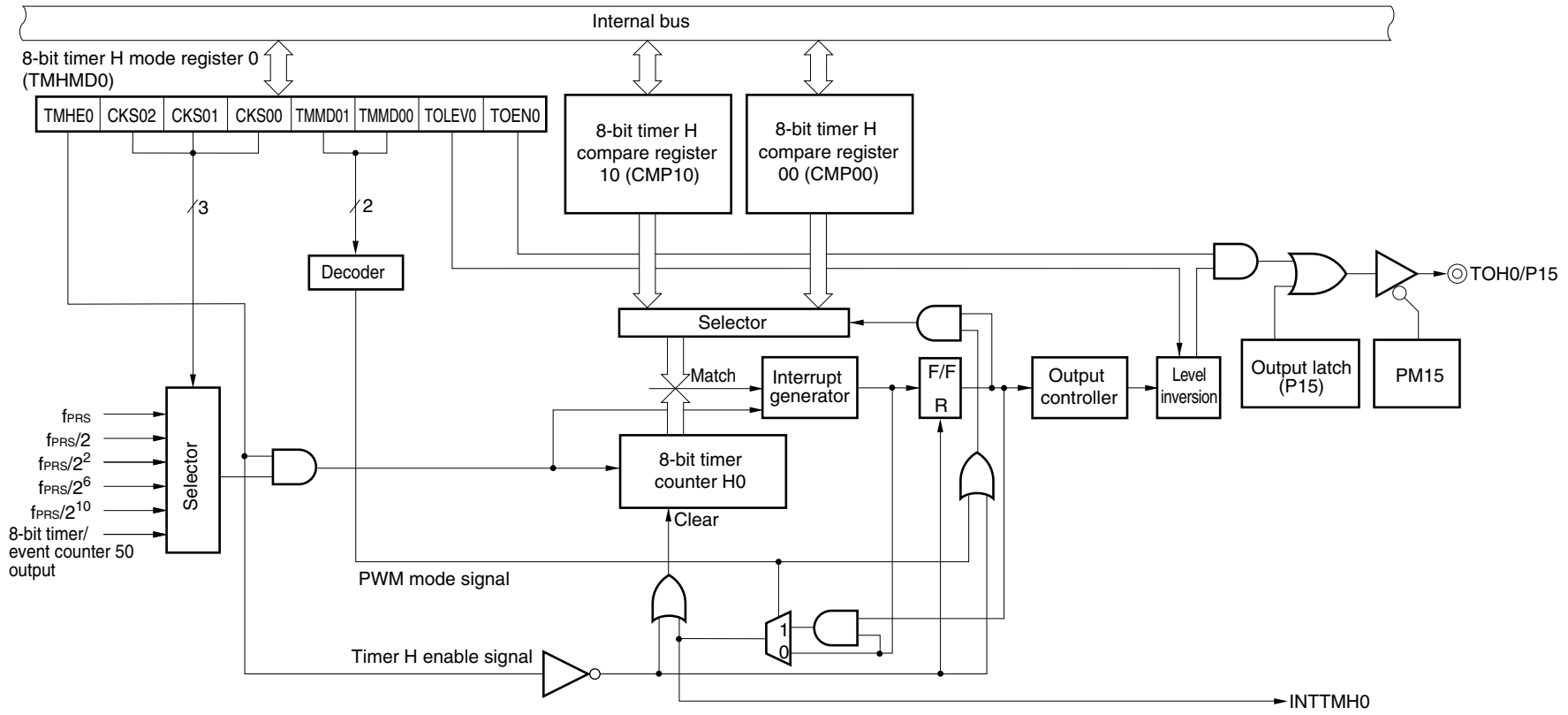

★Figure 9-2. Block Diagram of 8-Bit Timer H1

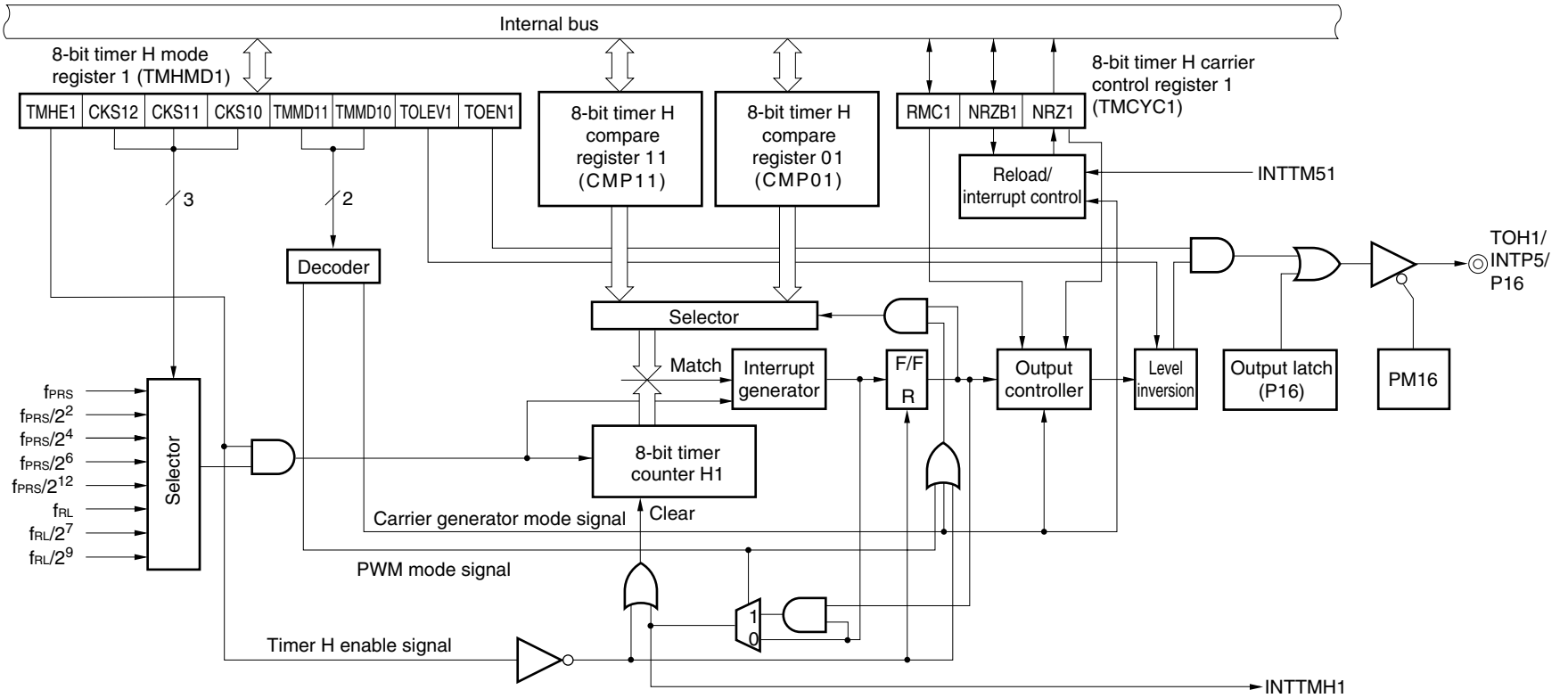

★ (1) **8-bit timer H compare register 0n (CMP0n)**

This register can be read or written by an 8-bit memory manipulation instruction. This register is used in all of the timer operation modes.

This register constantly compares the value set to CMP0n with the count value of the 8-bit timer counter Hn and, when the two values match, generates an interrupt request signal (INTTMHn) and inverts the output level of TOHn.

Rewrite the value of CMP0n while the timer is stopped (TMHEn = 0).

A reset signal generation sets this register to 00H.

Figure 9-3. Format of 8-Bit Timer H Compare Register 0n (CMP0n)

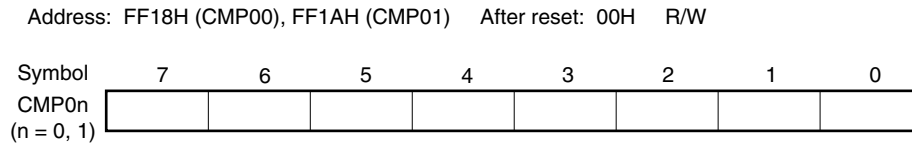

★ (2) **8-bit timer H compare register 1n (CMP1n)**

This register can be read or written by an 8-bit memory manipulation instruction. This register is used in the PWM output mode and carrier generator mode.

In the PWM output mode, this register constantly compares the value set to CMP1n with the count value of the 8-bit timer counter Hn and, when the two values match, inverts the output level of TOHn. No interrupt request signal is generated.

In the carrier generator mode, the CMP1n register always compares the value set to CMP1n with the count value of the 8-bit timer counter Hn and, when the two values match, generates an interrupt request signal (INTTMHn). At the same time, the count value is cleared.

CMP1n can be rewritten during timer count operation.

If the value of CMP1n is rewritten while the timer is operating, the new value is latched and transferred to CMP1n when the count value of the timer matches the old value of CMP1n, and then the value of CMP1n is changed to the new value. If matching of the count value and the CMP1n value and writing a value to CMP1n conflict, the value of CMP1n is not changed.

A reset signal generation sets this register to 00H.

Figure 9-4. Format of 8-Bit Timer H Compare Register 1n (CMP1n)

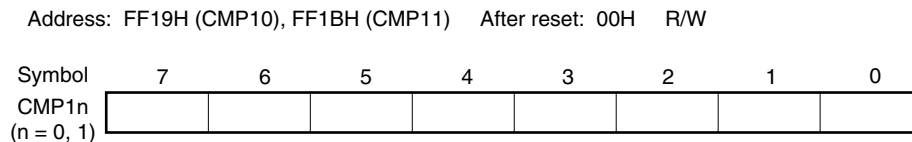

Caution In the PWM output mode and carrier generator mode, be sure to set CMP1n when starting the timer count operation (TMHEn = 1) after the timer count operation was stopped (TMHEn = 0) (be sure to set again even if setting the same value to CMP1n).

Remark n = 0, 1

9.3 Registers Controlling 8-Bit Timers H0 and H1

The following four registers are used to control 8-bit timers H0 and H1.

- 8-bit timer H mode register n (TMHMDn)
- 8-bit timer H carrier control register 1 (TMCYC1)^{Note}
- Port mode register 1 (PM1)
- Port register 1 (P1)

Note 8-bit timer H1 only

(1) 8-bit timer H mode register n (TMHMDn)

This register controls the mode of timer H.

This register can be set by a 1-bit or 8-bit memory manipulation instruction.

Reset signal generation sets this register to 00H.

Remark n = 0, 1

Figure 9-5. Format of 8-Bit Timer H Mode Register 0 (TMHMD0)

Address: FF69H After reset: 00H R/W

	<7>	6	5	4	3	2	<1>	<0>
TMHMD0	TMHE0	CKS02	CKS01	CKS00	TMMD01	TMMD00	TOLEV0	TOEN0

TMHE0	Timer operation enable
0	Stops timer count operation (counter is cleared to 0)
1	Enables timer count operation (count operation started by inputting clock)

CKS02	CKS01	CKS00	Count clock selection				
				f _{PRS} = 2 MHz	f _{PRS} = 5 MHz	f _{PRS} = 10 MHz	f _{PRS} = 20 MHz
0	0	0	f _{PRS}	2 MHz	5 MHz	10 MHz	20 MHz
0	0	1	f _{PRS} /2	1 MHz	2.5 MHz	5 MHz	10 MHz
0	1	0	f _{PRS} /2 ²	500 kHz	1.25 MHz	2.5 MHz	5 MHz
0	1	1	f _{PRS} /2 ⁶	31.25 kHz	78.13 kHz	156.25 kHz	312.5 kHz
1	0	0	f _{PRS} /2 ¹⁰	1.95 kHz	4.88 kHz	9.77 kHz	19.54 kHz
1	0	1	TM50 output ^{Note}				
Other than above			Setting prohibited				

TMMD01	TMMD00	Timer operation mode
0	0	Interval timer mode
1	0	PWM output mode
Other than above		Setting prohibited

TOLEV0	Timer output level control (in default mode)
0	Low level
1	High level

TOEN0	Timer output control
0	Disables output
1	Enables output

Note Note the following points when selecting the TM50 output as the count clock.

- Mode in which the count clock is cleared and started upon a match of TM50 and CR50 (TMC506 = 0)
Start the operation of the 8-bit timer/event counter 50 first and then enable the timer F/F inversion operation (TMC501 = 1).
- PWM mode (TMC506 = 1)
Start the operation of the 8-bit timer/event counter 50 first and then set the count clock to make the duty = 50%.

It is not necessary to enable the TO50 pin as a timer output pin in any mode.

- Cautions**
1. When $TMHE0 = 1$, setting the other bits of $TMHMD0$ is prohibited.
 2. In the PWM output mode, be sure to set the 8-bit timer H compare register 10 (CMP10) when starting the timer count operation ($TMHE0 = 1$) after the timer count operation was stopped ($TMHE0 = 0$) (be sure to set again even if setting the same value to CMP10).

- Remarks**
1. f_{PRS} : Peripheral hardware clock frequency
 2. TMC506: Bit 6 of 8-bit timer mode control register 50 (TMC50)
TMC501: Bit 1 of TMC50

Figure 9-6. Format of 8-Bit Timer H Mode Register 1 (TMHMD1)

Address: FF6CH After reset: 00H R/W

	<7>	6	5	4	3	2	<1>	<0>
TMHMD1	TMHE1	CKS12	CKS11	CKS10	TMMD11	TMMD10	TOLEV1	TOEN1

TMHE1	Timer operation enable
0	Stops timer count operation (counter is cleared to 0)
1	Enables timer count operation (count operation started by inputting clock)

CKS12	CKS11	CKS10	Count clock selection				
				$f_{PRS} = 2 \text{ MHz}$	$f_{PRS} = 5 \text{ MHz}$	$f_{PRS} = 10 \text{ MHz}$	$f_{PRS} = 20 \text{ MHz}$
0	0	0	f_{PRS}	2 MHz	5 MHz	10 MHz	20 MHz
0	0	1	$f_{PRS}/2^2$	500 kHz	1.25 MHz	2.5 MHz	5 MHz
0	1	0	$f_{PRS}/2^4$	125 kHz	312.5 kHz	625 kHz	1.25 MHz
0	1	1	$f_{PRS}/2^6$	31.25 kHz	78.13 kHz	156.25 kHz	312.5 kHz
1	0	0	$f_{PRS}/2^{12}$	0.49 kHz	1.22 kHz	2.44 kHz	4.88 kHz
1	0	1	$f_{RL}/2^7$	1.88 kHz (TYP.)			
1	1	0	$f_{RL}/2^9$	0.47 kHz (TYP.)			
1	1	1	f_{RL}	240 kHz (TYP.)			

TMMD11	TMMD10	Timer operation mode
0	0	Interval timer mode
0	1	Carrier generator mode
1	0	PWM output mode
1	1	Setting prohibited

TOLEV1	Timer output level control (in default mode)
0	Low level
1	High level

TOEN1	Timer output control
0	Disables output
1	Enables output

- Cautions**
1. When TMHE1 = 1, setting the other bits of TMHMD1 is prohibited.
 2. In the PWM output mode and carrier generator mode, be sure to set the 8-bit timer H compare register 11 (CMP11) when starting the timer count operation (TMHE1 = 1) after the timer count operation was stopped (TMHE1 = 0) (be sure to set again even if setting the same value to CMP11).
 3. When the carrier generator mode is used, set so that the count clock frequency of TMH1 becomes more than 6 times the count clock frequency of TM51.

- Remarks**
1. f_{PRS} : Peripheral hardware clock frequency
 2. f_{RL} : Internal low-speed oscillation clock frequency

(2) 8-bit timer H carrier control register 1 (TMCYC1)

This register controls the remote control output and carrier pulse output status of 8-bit timer H1.

This register can be set by a 1-bit or 8-bit memory manipulation instruction.

Reset signal generation sets this register to 00H.

Figure 9-7. Format of 8-Bit Timer H Carrier Control Register 1 (TMCYC1)

Address: FF6DH After reset: 00H R/W^{Note}

	7	6	5	4	3	2	1	<0>
TMCYC1	0	0	0	0	0	RMC1	NRZB1	NRZ1

RMC1	NRZB1	Remote control output
0	0	Low-level output
0	1	High-level output
1	0	Low-level output
1	1	Carrier pulse output

NRZ1	Carrier pulse output status flag
0	Carrier output disabled status (low-level status)
1	Carrier output enabled status (RMC1 = 1: Carrier pulse output, RMC1 = 0: High-level status)

Note Bit 0 is read-only.

(3) Port mode register 1 (PM1)

This register sets port 1 input/output in 1-bit units.

When using the P15/TOH0 and P16/TOH1/INTP5 pins for timer output, clear PM15 and PM16 and the output latches of P15 and P16 to 0.

PM1 can be set by a 1-bit or 8-bit memory manipulation instruction.

Reset signal generation sets this register to FFH.

Figure 9-8. Format of Port Mode Register 1 (PM1)

Address: FF21H After reset: FFH R/W

Symbol	7	6	5	4	3	2	1	0
PM1	PM17	PM16	PM15	PM14	PM13	PM12	PM11	PM10

PM1n	P1n pin I/O mode selection (n = 0 to 7)
0	Output mode (output buffer on)
1	Input mode (output buffer off)

9.4 Operation of 8-Bit Timers H0 and H1

9.4.1 Operation as interval timer/square-wave output

When the 8-bit timer counter H_n and compare register 0_n (CMP 0_n) match, an interrupt request signal (INTTMH $_n$) is generated and the 8-bit timer counter H_n is cleared to 00H.

Compare register 1_n (CMP 1_n) is not used in interval timer mode. Since a match of the 8-bit timer counter H_n and the CMP 1_n register is not detected even if the CMP 1_n register is set, timer output is not affected.

By setting bit 0 (TOEN $_n$) of timer H mode register n (TMHMD $_n$) to 1, a square wave of any frequency (duty = 50%) is output from TOH $_n$.

Setting

<1> Set each register.

Figure 9-9. Register Setting During Interval Timer/Square-Wave Output Operation

(i) Setting timer H mode register n (TMHMD $_n$)

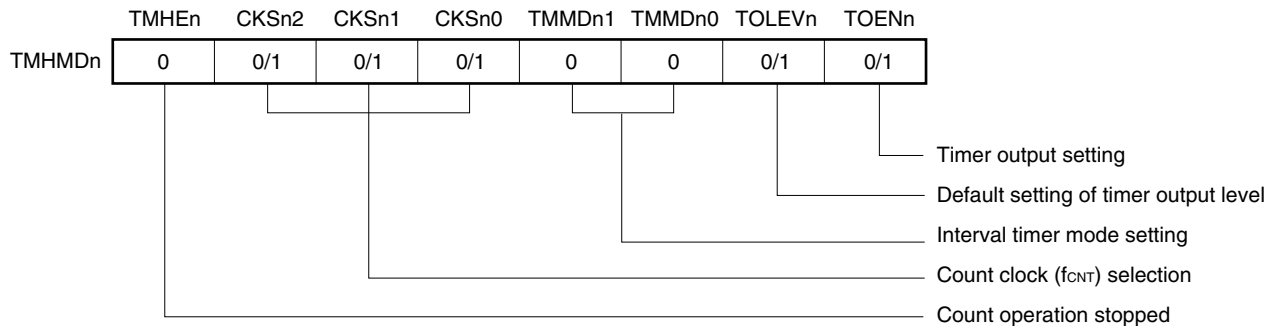

(ii) CMP 0_n register setting

The interval time is as follows if N is set as a comparison value.

- Interval time = $(N + 1)/f_{CNT}$

<2> Count operation starts when TMHE $_n$ = 1.

<3> When the values of the 8-bit timer counter H_n and the CMP 0_n register match, the INTTMH $_n$ signal is generated and the 8-bit timer counter H_n is cleared to 00H.

<4> Subsequently, the INTTMH $_n$ signal is generated at the same interval. To stop the count operation, clear TMHE $_n$ to 0.

Remarks 1. For the setting of the output pin, see 9.3 (3) Port mode register 1 (PM1).

2. For how to enable the INTTMH $_n$ signal interrupt, see CHAPTER 19 INTERRUPT FUNCTIONS.

3. $n = 0, 1$

Figure 9-10. Timing of Interval Timer/Square-Wave Output Operation (1/2)

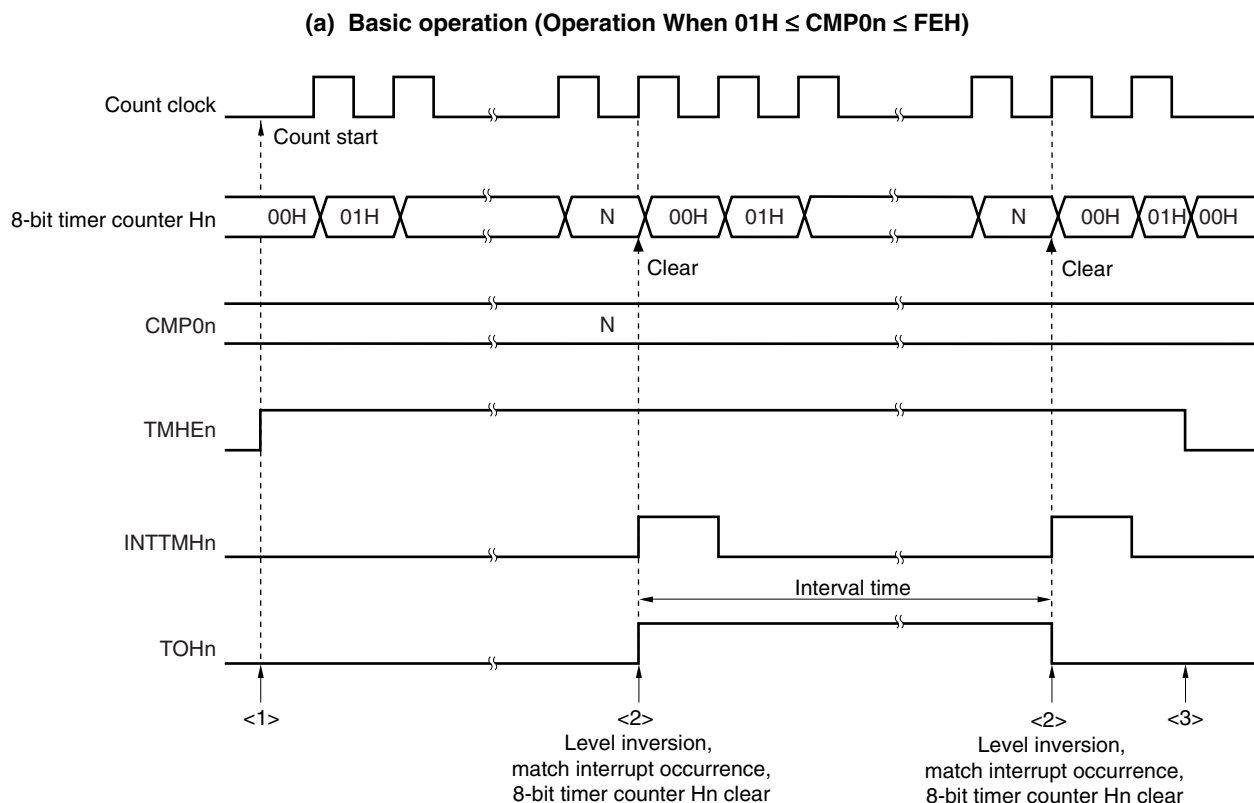

- <1> The count operation is enabled by setting the TMHEn bit to 1. The count clock starts counting no more than 1 clock after the operation is enabled.
- <2> When the value of the 8-bit timer counter Hn matches the value of the CMP0n register, the value of the timer counter is cleared, and the level of the TOHn output is inverted. In addition, the INTTMHn signal is output at the rising edge of the count clock.
- <3> If the TMHEn bit is cleared to 0 while timer H is operating, the INTTMHn signal and TOHn output are set to the default level. If they are already at the default level before the TMHEn bit is cleared to 0, then that level is maintained.

Remark $n = 0, 1$
 $01H \leq N \leq FEH$

Figure 9-10. Timing of Interval Timer/Square-Wave Output Operation (2/2)

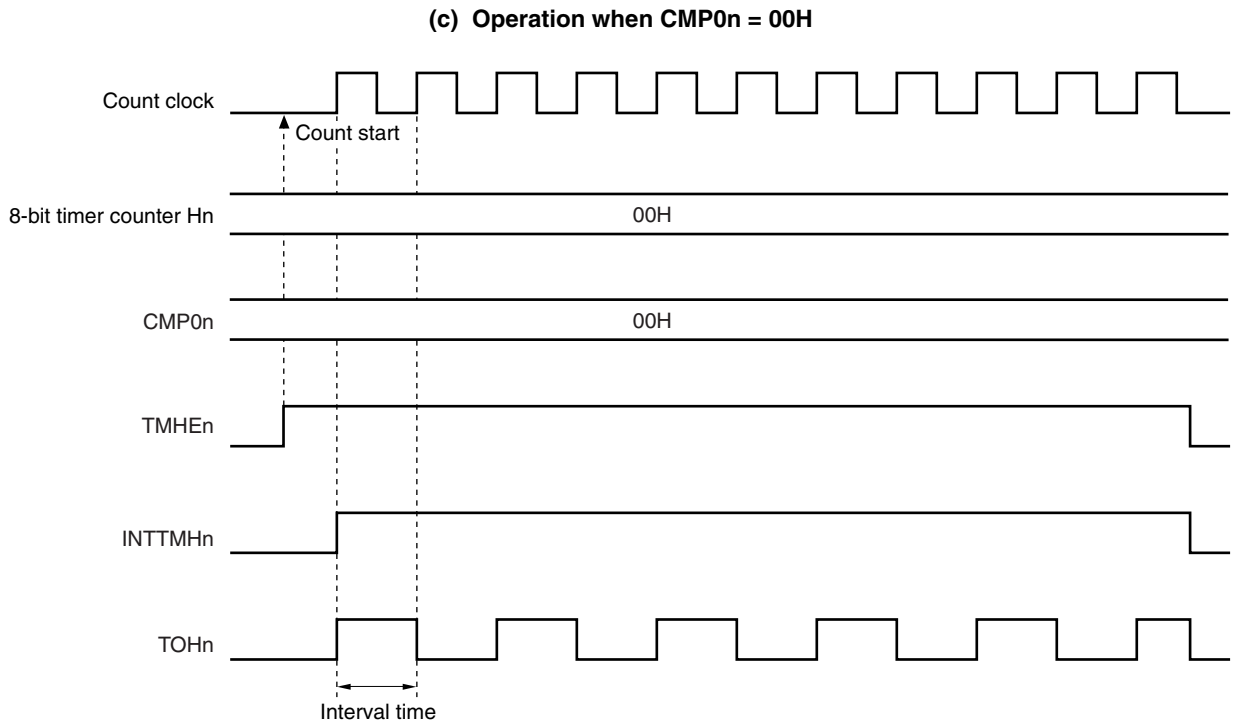
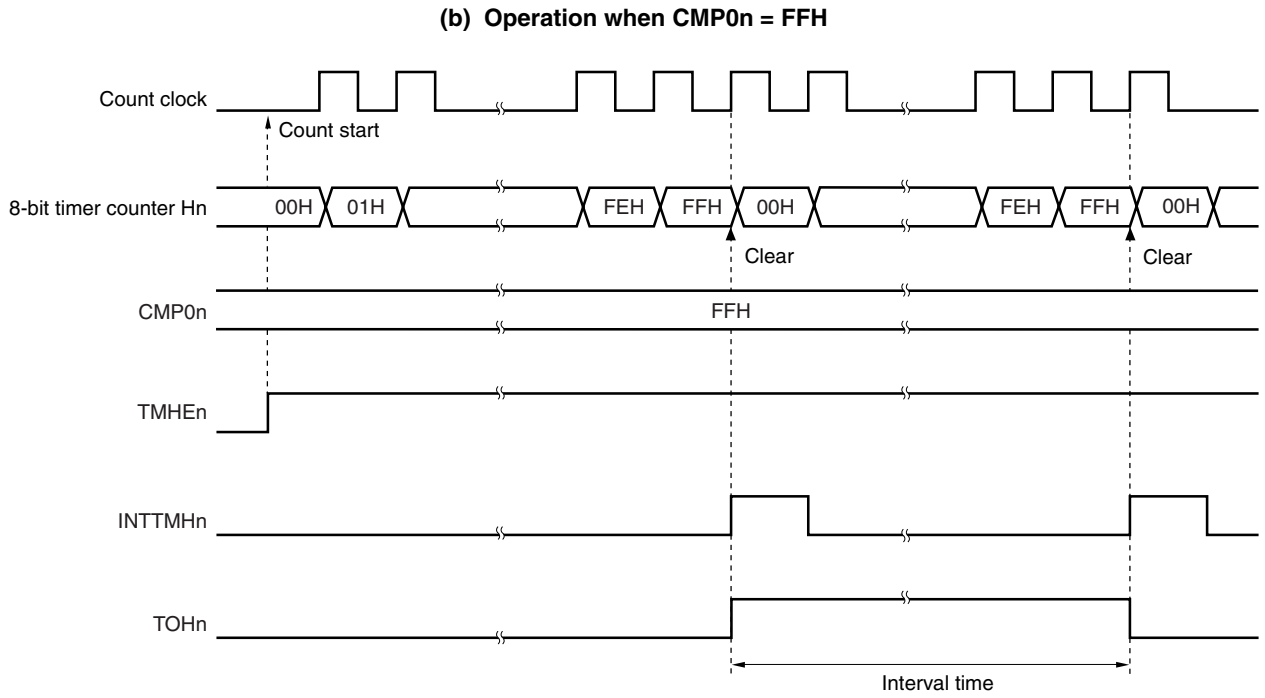

Remark n = 0, 1

9.4.2 Operation as PWM output

In PWM output mode, a pulse with an arbitrary duty and arbitrary cycle can be output.

The 8-bit timer compare register 0n (CMP0n) controls the cycle of timer output (TOHn). Rewriting the CMP0n register during timer operation is prohibited.

The 8-bit timer compare register 1n (CMP1n) controls the duty of timer output (TOHn). Rewriting the CMP1n register during timer operation is possible.

The operation in PWM output mode is as follows.

The TOHn output level is inverted and the 8-bit timer counter Hn is cleared to 0 when the 8-bit timer counter Hn and the CMP0n register match after the timer count is started. The TOHn output level is inverted when the 8-bit timer counter Hn and the CMP1n register match.

Setting

<1> Set each register.

Figure 9-11. Register Setting in PWM Output Mode

(i) Setting timer H mode register n (TMHMDn)

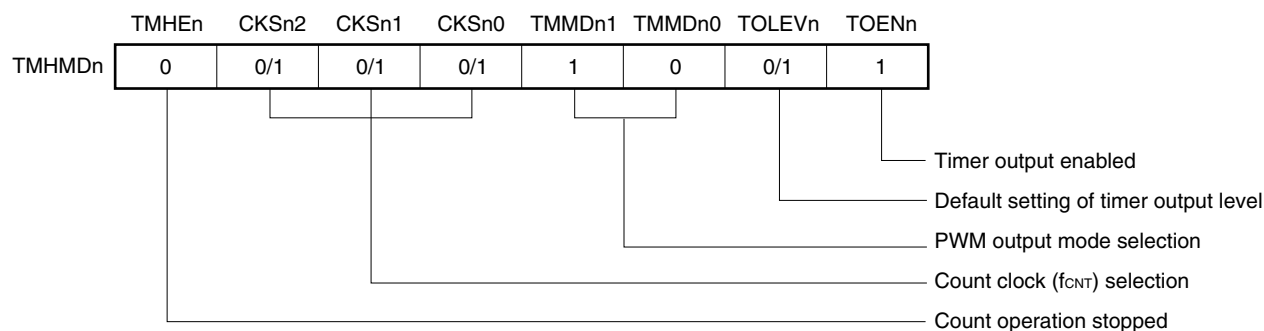

(ii) Setting CMP0n register

- Compare value (N): Cycle setting

(iii) Setting CMP1n register

- Compare value (M): Duty setting

Remarks 1. $n = 0, 1$

2. $00H \leq \text{CMP1n (M)} < \text{CMP0n (N)} \leq \text{FFH}$

<2> The count operation starts when TMHE_n = 1.

<3> The CMP0n register is the compare register that is to be compared first after counter operation is enabled. When the values of the 8-bit timer counter H_n and the CMP0n register match, the 8-bit timer counter H_n is cleared, an interrupt request signal (INTTMH_n) is generated, and TOH_n output is inverted. At the same time, the compare register to be compared with the 8-bit timer counter H_n is changed from the CMP0n register to the CMP1n register.

<4> When the 8-bit timer counter H_n and the CMP1n register match, TOH_n output is inverted and the compare register to be compared with the 8-bit timer counter H_n is changed from the CMP1n register to the CMP0n register. At this time, the 8-bit timer counter H_n is not cleared and the INTTMH_n signal is not generated.

- <5> By performing procedures <3> and <4> repeatedly, a pulse with an arbitrary duty can be obtained.
- <6> To stop the count operation, set TMHEn = 0.

If the setting value of the CMP0n register is N, the setting value of the CMP1n register is M, and the count clock frequency is f_{CNT} , the PWM pulse output cycle and duty are as follows.

- PWM pulse output cycle = $(N + 1)/f_{CNT}$
- Duty = $(M + 1)/(N + 1)$

- Cautions**
1. The set value of the CMP1n register can be changed while the timer counter is operating. However, this takes a duration of three operating clocks (signal selected by the CKSn2 to CKSn0 bits of the TMHMDn register) from when the value of the CMP1n register is changed until the value is transferred to the register.
 2. Be sure to set the CMP1n register when starting the timer count operation (TMHEn = 1) after the timer count operation was stopped (TMHEn = 0) (be sure to set again even if setting the same value to the CMP1n register).
 3. Make sure that the CMP1n register setting value (M) and CMP0n register setting value (N) are within the following range.
 $00H \leq \text{CMP1n (M)} < \text{CMP0n (N)} \leq \text{FFH}$

- Remarks**
1. For the setting of the output pin, see **9.3 (3) Port mode register 1 (PM1)**.
 2. For details on how to enable the INTTMHn signal interrupt, see **CHAPTER 19 INTERRUPT FUNCTIONS**.
 3. n = 0, 1

Figure 9-12. Operation Timing in PWM Output Mode (1/4)

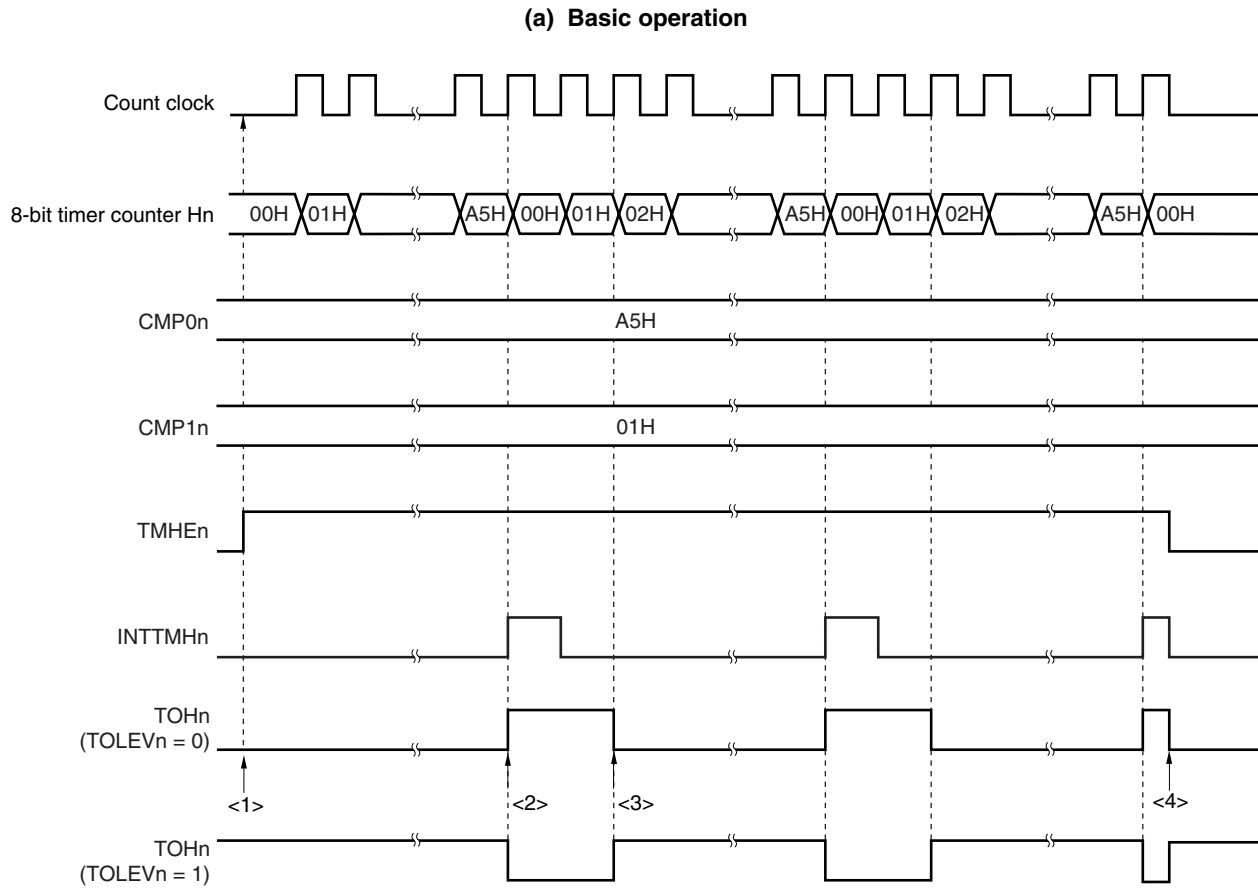

- <1> The count operation is enabled by setting the TMHEn bit to 1. Start the 8-bit timer counter Hn by masking one count clock to count up. At this time, TOHn output remains the default.
- <2> When the values of the 8-bit timer counter Hn and the CMP0n register match, the TOHn output level is inverted, the value of the 8-bit timer counter Hn is cleared, and the INTTMHn signal is output.
- <3> When the values of the 8-bit timer counter Hn and the CMP1n register match, the TOHn output level is inverted. At this time, the 8-bit timer counter value is not cleared and the INTTMHn signal is not output.
- <4> Clearing the TMHEn bit to 0 during timer Hn operation sets the INTTMHn signal and TOHn output to the default.

Remark n = 0, 1

Figure 9-12. Operation Timing in PWM Output Mode (2/4)

(b) Operation when $CMP0n = FFH$, $CMP1n = 00H$

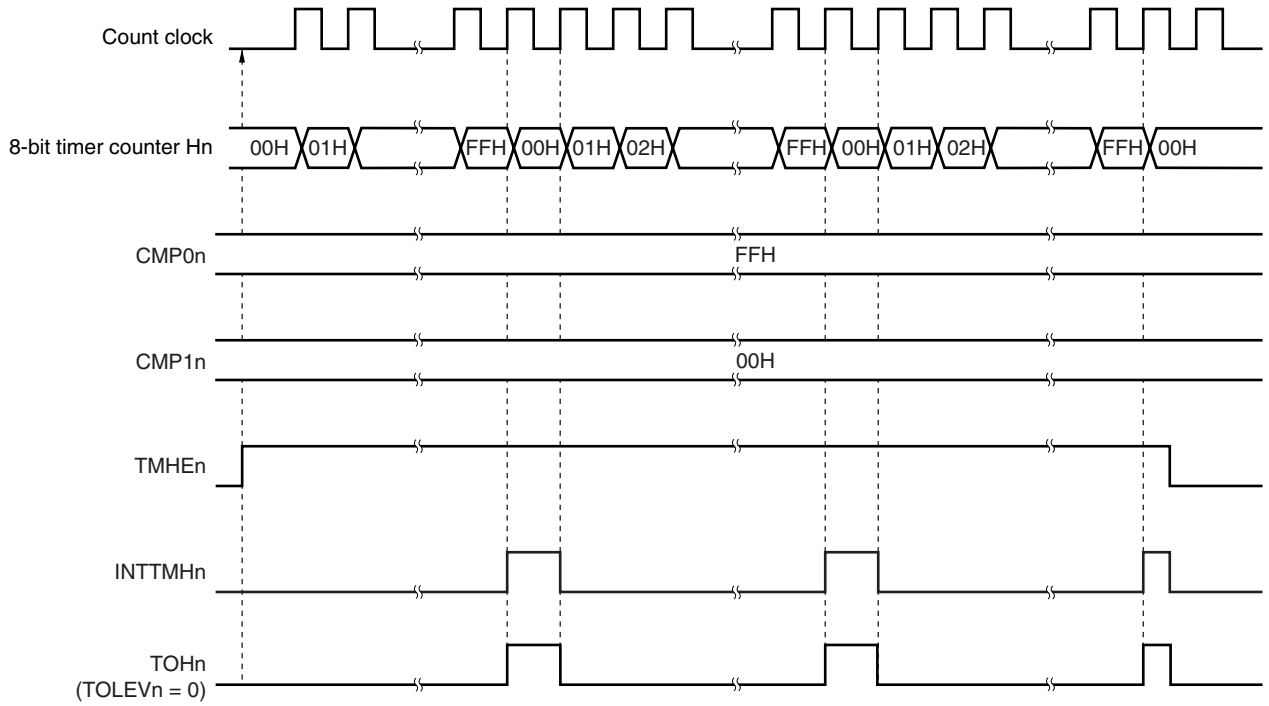

(c) Operation when $CMP0n = FFH$, $CMP1n = FEH$

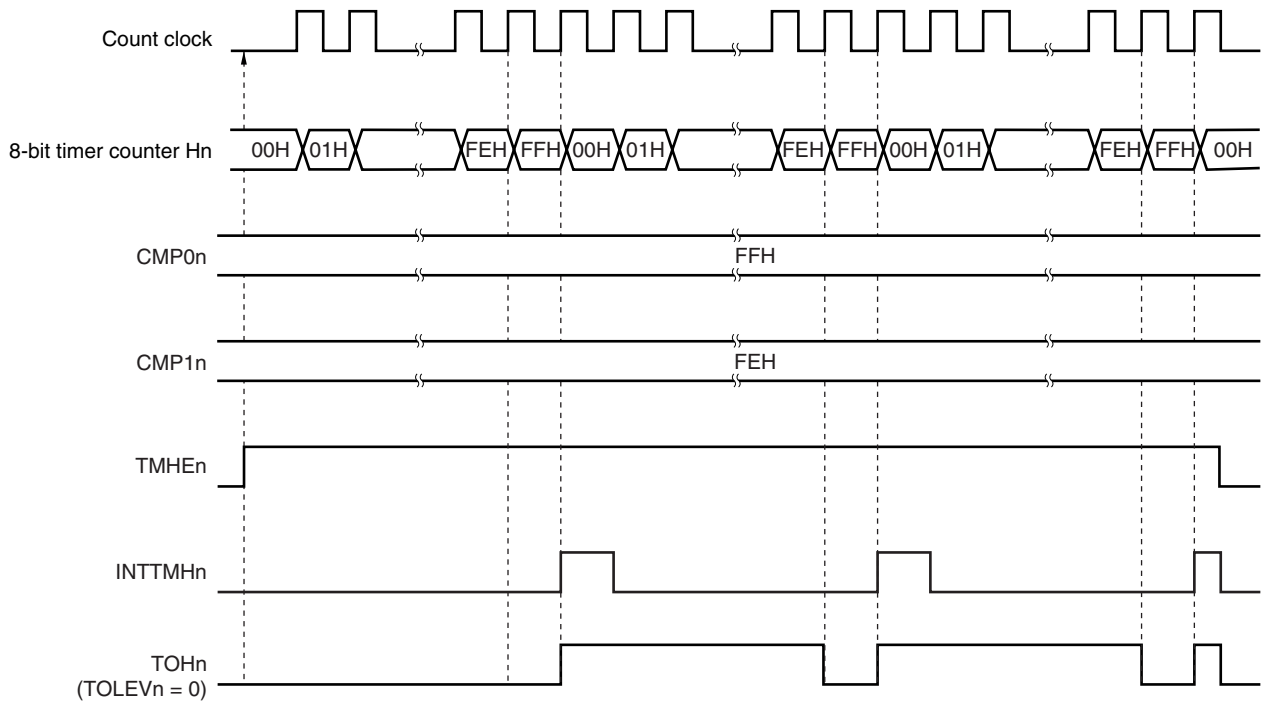

Remark n = 0, 1

Figure 9-12. Operation Timing in PWM Output Mode (3/4)

(d) Operation when $CMP0n = 01H$, $CMP1n = 00H$

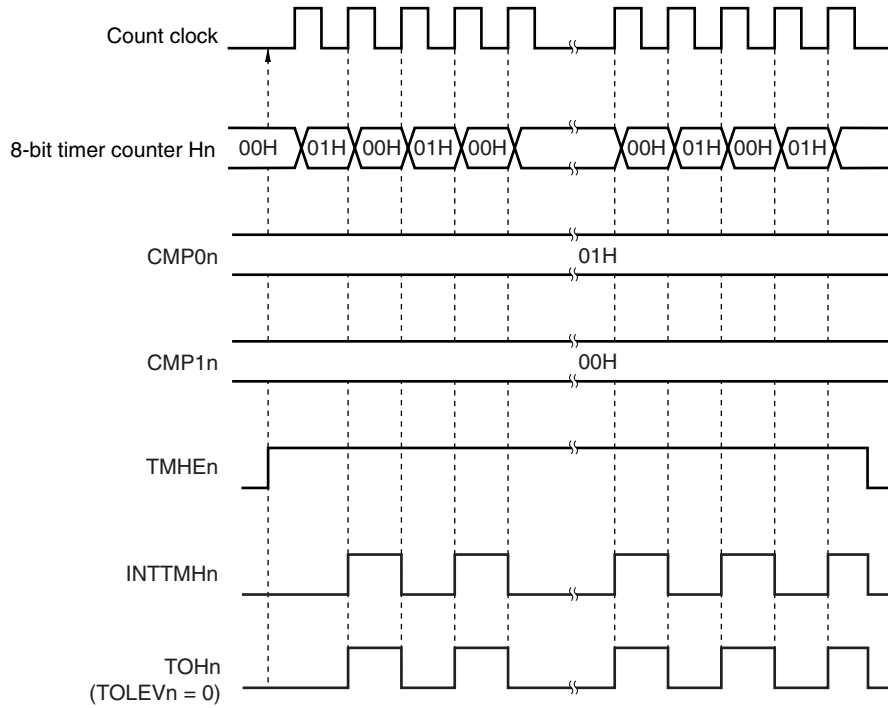

Remark n = 0, 1

Figure 9-12. Operation Timing in PWM Output Mode (4/4)

(e) Operation by changing CMP1n (CMP1n = 02H → 03H, CMP0n = A5H)

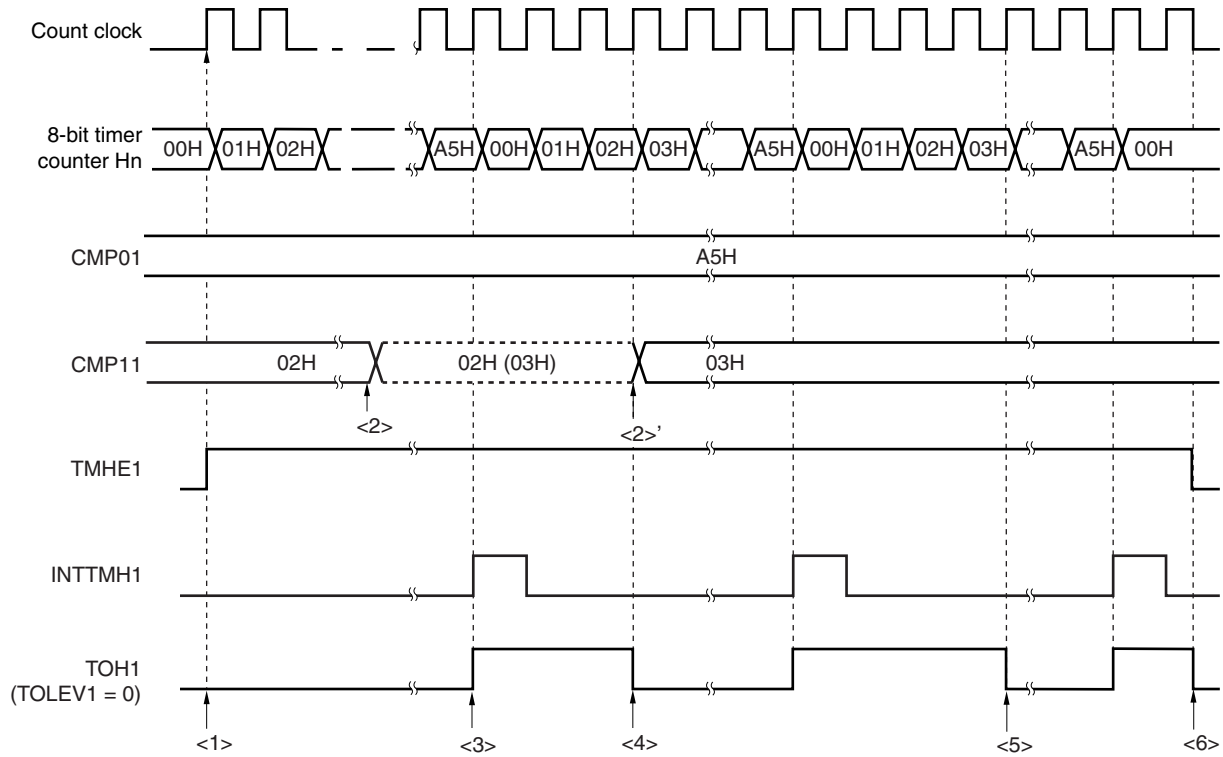

9.4.3 Carrier generator operation (8-bit timer H1 only)

- ★ In the carrier generator mode, the 8-bit timer H1 is used to generate the carrier signal of an infrared remote controller, and the 8-bit timer/event counter 51 is used to generate an infrared remote control signal (time count).

The carrier clock generated by the 8-bit timer H1 is output in the cycle set by the 8-bit timer/event counter 51.

In carrier generator mode, the output of the 8-bit timer H1 carrier pulse is controlled by the 8-bit timer/event counter 51, and the carrier pulse is output from the TOH1 output.

(1) Carrier generation

In carrier generator mode, the 8-bit timer H compare register 01 (CMP01) generates a low-level width carrier pulse waveform and the 8-bit timer H compare register 11 (CMP11) generates a high-level width carrier pulse waveform.

Rewriting the CMP11 register during the 8-bit timer H1 operation is possible but rewriting the CMP01 register is prohibited.

(2) Carrier output control

Carrier output is controlled by the interrupt request signal (INTTM51) of the 8-bit timer/event counter 51 and the NRZB1 and RMC1 bits of the 8-bit timer H carrier control register (TMCYC1). The relationship between the outputs is shown below.

RMC1 Bit	NRZB1 Bit	Output
0	0	Low-level output
0	1	High-level output
1	0	Low-level output
1	1	Carrier pulse output

To control the carrier pulse output during a count operation, the NRZ1 and NRZB1 bits of the TMCYC1 register have a master and slave bit configuration. The NRZ1 bit is read-only but the NRZB1 bit can be read and written. The INTTM51 signal is synchronized with the 8-bit timer H1 count clock and is output as the INTTM5H1 signal. The INTTM5H1 signal becomes the data transfer signal of the NRZ1 bit, and the NRZB1 bit value is transferred to the NRZ1 bit. The timing for transfer from the NRZB1 bit to the NRZ1 bit is as shown below.

Figure 9-13. Transfer Timing

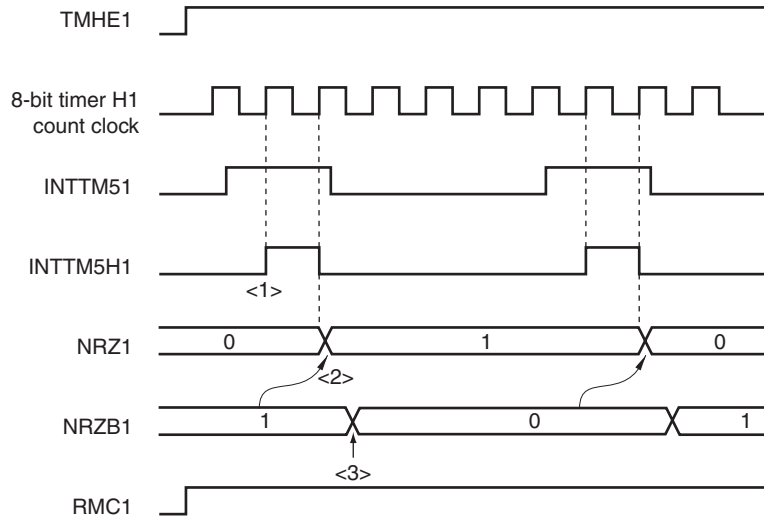

- <1> The INTTM51 signal is synchronized with the count clock of the 8-bit timer H1 and is output as the INTTM5H1 signal.
- <2> The value of the NRZB1 bit is transferred to the NRZ1 bit at the second clock from the rising edge of the INTTM5H1 signal.
- ★ <3> Write the next value to the NRZB1 bit in the interrupt servicing program that has been started by the INTTM5H1 interrupt or after timing has been checked by polling the interrupt request flag. Write data to count the next time to the CR51 register.

- Cautions**
1. Do not rewrite the NRZB1 bit again until at least the second clock after it has been rewritten, or else the transfer from the NRZB1 bit to the NRZ1 bit is not guaranteed.
 2. When the 8-bit timer/event counter 51 is used in the carrier generator mode, an interrupt is generated at the timing of <1>. When the 8-bit timer/event counter 51 is used in a mode other than the carrier generator mode, the timing of the interrupt generation differs.

Setting

<1> Set each register.

Figure 9-14. Register Setting in Carrier Generator Mode

(i) Setting 8-bit timer H mode register 1 (TMHMD1)

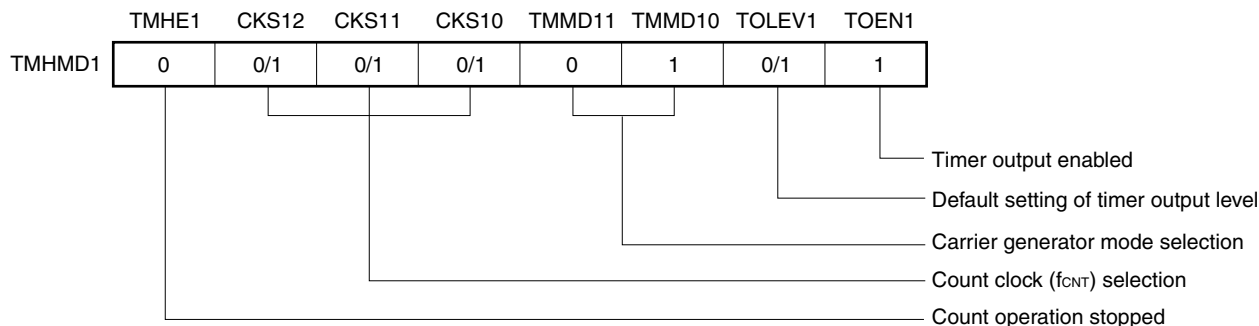

(ii) CMP01 register setting

- Compare value

(iii) CMP11 register setting

- Compare value

(iv) TMCYC1 register setting

- RMC1 = 1 ... Remote control output enable bit
- NRZB1 = 0/1 ... carrier output enable bit

(v) TCL51 and TMC51 register setting

- See 8.3 Registers Controlling 8-Bit Timer/Event Counters 50 and 51.

<2> When TMHE1 = 1, the 8-bit timer H1 starts counting.

<3> When TCE51 of the 8-bit timer mode control register 51 (TMC51) is set to 1, the 8-bit timer/event counter 51 starts counting.

<4> After the count operation is enabled, the first compare register to be compared is the CMP01 register. When the count value of the 8-bit timer counter H1 and the CMP01 register value match, the INTTMH1 signal is generated, the 8-bit timer counter H1 is cleared. At the same time, the compare register to be compared with the 8-bit timer counter H1 is switched from the CMP01 register to the CMP11 register.

<5> When the count value of the 8-bit timer counter H1 and the CMP11 register value match, the INTTMH1 signal is generated, the 8-bit timer counter H1 is cleared. At the same time, the compare register to be compared with the 8-bit timer counter H1 is switched from the CMP11 register to the CMP01 register.

<6> By performing procedures <4> and <5> repeatedly, a carrier clock is generated.

<7> The INTTM51 signal is synchronized with count clock of the 8-bit timer H1 and output as the INTTM5H1 signal. The INTTM5H1 signal becomes the data transfer signal for the NRZB1 bit, and the NRZB1 bit value is transferred to the NRZ1 bit.

★ <8> Write the next value to the NRZB1 bit in the interrupt servicing program that has been started by the INTTM5H1 interrupt or after timing has been checked by polling the interrupt request flag. Write data to count the next time to the CR51 register.

<9> When the NRZ1 bit is high level, a carrier clock is output from the TOH1 pin.

<10> By performing the procedures above, an arbitrary carrier

Figure 9-15. Carrier Generator Mode Operation Timing (1/3)

(a) Operation when $CMP01 = N$, $CMP11 = N$

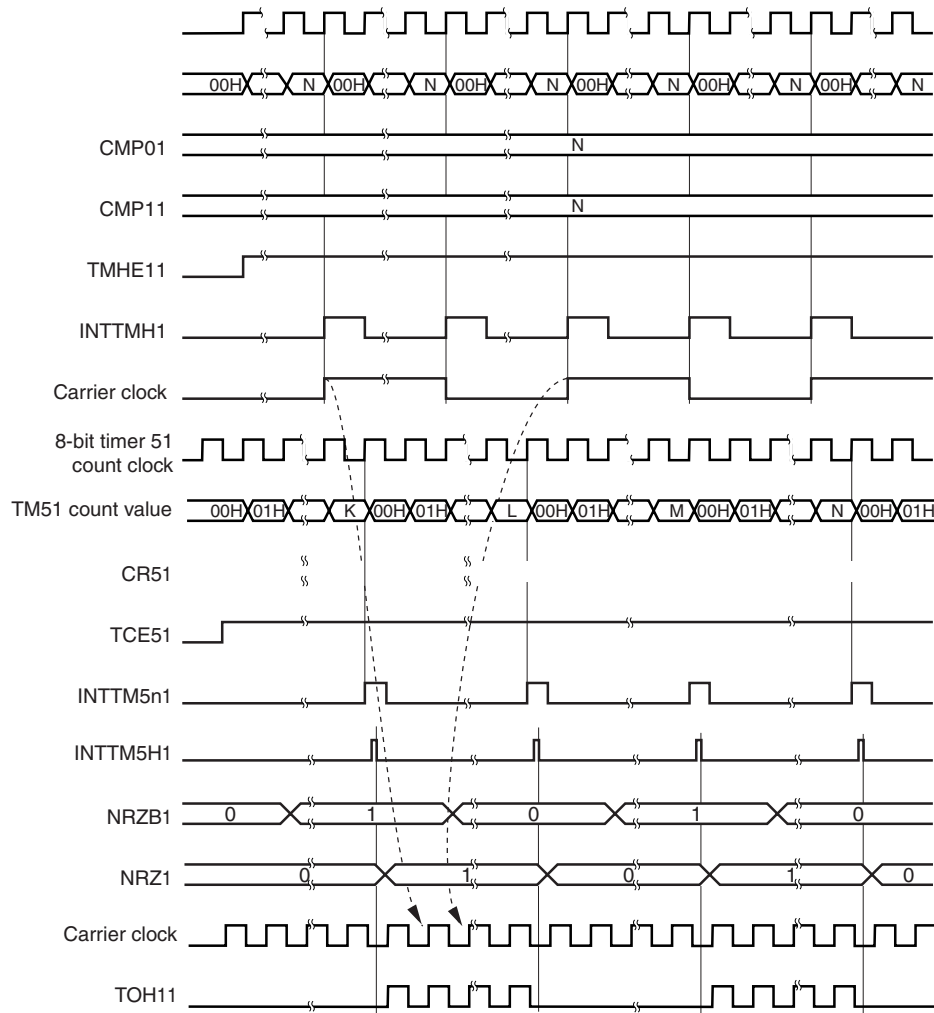
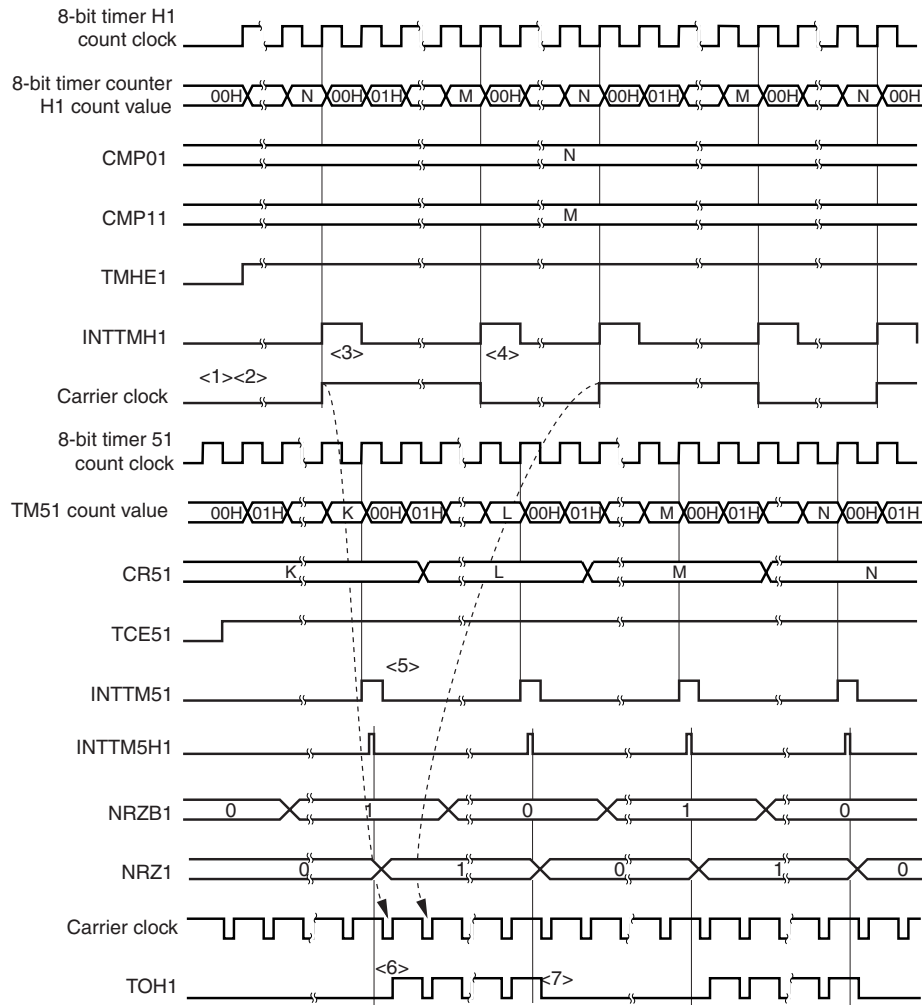

Figure 9-15. Carrier Generator Mode Operation Timing (2/3)

(b) Operation when CMP01 = N, CMP11 = M



- <1> When TMHE1 = 0 and TCE51 = 0, the 8-bit timer counter H1 operation is stopped.
- <2> When TMHE1 = 1 is set, the 8-bit timer counter H1 starts a count operation. At that time, the carrier clock remains default.
- <3> When the count value of the 8-bit timer counter H1 matches the CMP01 register value, the first INTTMH1 signal is generated, the carrier clock signal is inverted, and the compare register to be compared with the 8-bit timer counter H1 is switched from the CMP01 register to the CMP11 register. The 8-bit timer counter H1 is cleared to 00H.
- <4> When the count value of the 8-bit timer counter H1 matches the CMP11 register value, the INTTMH1 signal is generated, the carrier clock signal is inverted, and the compare register to be compared with the 8-bit timer counter H1 is switched from the CMP11 register to the CMP01 register. The 8-bit timer counter H1 is cleared to 00H. By performing procedures <3> and <4> repeatedly, a carrier clock with duty fixed to other than 50% is generated.
- <5> When the INTTM51 signal is generated, it is synchronized with the 8-bit timer H1 count clock and is output as the INTTM5H1 signal.
- <6> A carrier signal is output at the first rising edge of the carrier clock if NRZ1 is set to 1.
- <7> When NRZ1 = 0, the TOH1 output is held at the high level and is not changed to low level while the carrier clock is high level (from <6> and <7>, the high-level width of the carrier clock waveform is guaranteed).

Figure 9-15. Carrier Generator Mode Operation Timing (3/3)

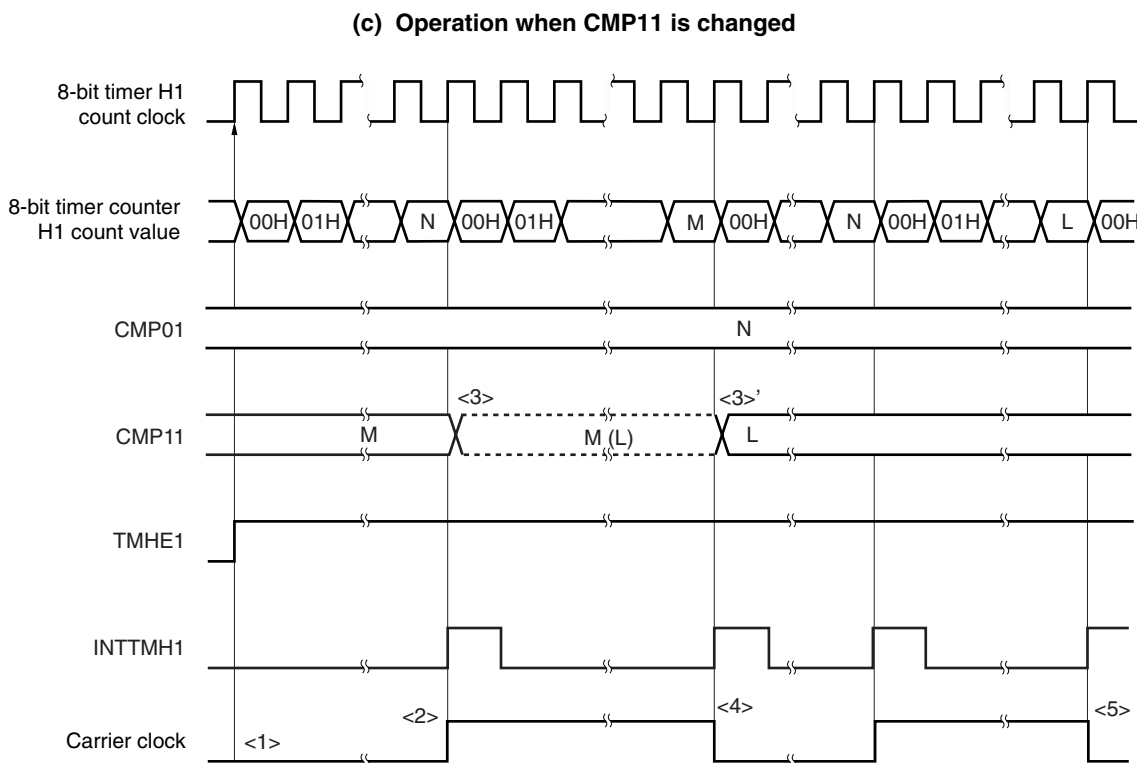

<1> When $TMHE1 = 1$ is set, the 8-bit timer H1 starts a count operation. At that time, the carrier clock remains default.

★ <2> When the count value of the 8-bit timer counter H1 matches the value of the CMP01 register, the INTTMH1 signal is output, the carrier signal is inverted, and the timer counter is cleared to 00H. At the same time, the compare register whose value is to be compared with that of the 8-bit timer counter H1 is changed from the CMP01 register to the CMP11 register.

★ <3> The CMP11 register is asynchronous to the count clock, and its value can be changed while the 8-bit timer H1 is operating. The new value (L) to which the value of the register is to be changed is latched. When the count value of the 8-bit timer counter H1 matches the value (M) of the CMP11 register before the change, the CMP11 register is changed (<3>').

However, it takes three count clocks or more since the value of the CMP11 register has been changed until the value is transferred to the register. Even if a match signal is generated before the duration of three count clocks elapses, the new value is not transferred to the register.

★ <4> When the count value of 8-bit timer counter H1 matches the value (M) of the CMP1 register before the change, the INTTMH1 signal is output, the carrier signal is inverted, and the timer counter is cleared to 00H. At the same time, the compare register whose value is to be compared with that of the 8-bit timer counter H1 is changed from the CMP11 register to the CMP01 register.

<5> The timing at which the count value of the 8-bit timer counter H1 and the CMP11 register value match again is indicated by the value after the change (L).

CHAPTER 10 WATCH TIMER

10.1 Functions of Watch Timer

The watch timer has the following functions.

- Watch timer
- Interval timer

The watch timer and the interval timer can be used simultaneously.

Figure 10-1 shows the watch timer block diagram.

Figure 10-1. Block Diagram of Watch Timer

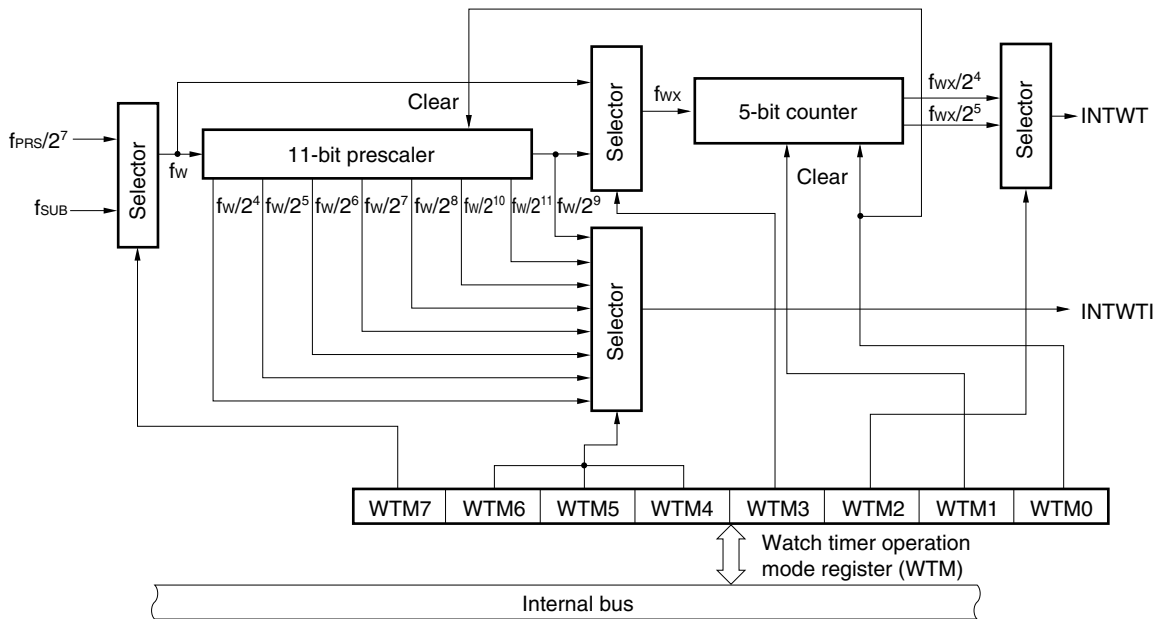

Remark f_{PRS} : Peripheral hardware clock frequency
 f_{SUB} : Subsystem clock frequency
 f_w : Watch timer clock frequency ($f_{PRS}/2^7$ or f_{SUB})
 f_{wx} : f_w or $f_w/2^9$

(1) Watch timer

When the peripheral hardware clock or subsystem clock is used, interrupt request signals (INTWT) are generated at preset intervals.

Table 10-1. Watch Timer Interrupt Time

Interrupt Time	When Operated at $f_{SUB} = 32.768 \text{ kHz}$	When Operated at $f_{PRS} = 2 \text{ MHz}$	When Operated at $f_{PRS} = 5 \text{ MHz}$	When Operated at $f_{PRS} = 10 \text{ MHz}$	When Operated at $f_{PRS} = 20 \text{ MHz}$
$2^4/f_w$	488 μs	1.02 ms	410 μs	205 μs	102 μs
$2^5/f_w$	977 μs	2.05 ms	819 μs	410 μs	205 μs
$2^{10}/f_w$	0.25 s	0.52 s	0.210 s	0.105 s	52.5 ms
$2^{14}/f_w$	0.5 s	1.05 s	0.419 s	0.210 s	0.105 s

Remark f_{PRS} : Peripheral hardware clock frequency
 f_{SUB} : Subsystem clock frequency
 f_w : Watch timer clock frequency ($f_{PRS}/2^7$ or f_{SUB})

(2) Interval timer

Interrupt request signals (INTWTI) are generated at preset time intervals.

Table 10-2. Interval Timer Interval Time

Interval Time	When Operated at $f_{SUB} = 32.768 \text{ kHz}$	When Operated at $f_{PRS} = 2 \text{ MHz}$	When Operated at $f_{PRS} = 5 \text{ MHz}$	When Operated at $f_{PRS} = 10 \text{ MHz}$	When Operated at $f_{PRS} = 20 \text{ MHz}$
$2^4/f_w$	488 μs	1.02 ms	410 μs	205 μs	102 μs
$2^5/f_w$	977 μs	2.05 ms	820 μs	410 μs	205 μs
$2^8/f_w$	1.95 ms	4.10 ms	1.64 ms	820 μs	410 μs
$2^7/f_w$	3.91 ms	8.20 ms	3.28 ms	1.64 ms	820 μs
$2^9/f_w$	7.81 ms	16.4 ms	6.55 ms	3.28 ms	1.64 ms
$2^9/f_w$	15.6 ms	32.8 ms	13.1 ms	6.55 ms	3.28 ms
$2^{10}/f_w$	31.3 ms	65.5 ms	26.2 ms	13.1 ms	6.55 ms
$2^{11}/f_w$	62.5 ms	131.1 ms	52.4 ms	26.2 ms	13.1 ms

Remark f_{PRS} : Peripheral hardware clock frequency
 f_{SUB} : Subsystem clock frequency
 f_w : Watch timer clock frequency ($f_{PRS}/2^7$ or f_{SUB})

10.2 Configuration of Watch Timer

The watch timer includes the following hardware.

Table 10-3. Watch Timer Configuration

Item	Configuration
Counter	5 bits \times 1
Prescaler	11 bits \times 1
Control register	Watch timer operation mode register (WTM)

10.3 Register Controlling Watch Timer

The watch timer is controlled by the watch timer operation mode register (WTM).

- **Watch timer operation mode register (WTM)**

This register sets the watch timer count clock, enables/disables operation, prescaler interval time, and 5-bit counter operation control.

WTM is set by a 1-bit or 8-bit memory manipulation instruction.

Reset signal generation sets WTM to 00H.

Figure 10-2. Format of Watch Timer Operation Mode Register (WTM)

Address: FF6FH After reset: 00H R/W

Symbol	7	6	5	4	3	2	<1>	<0>
WTM	WTM7	WTM6	WTM5	WTM4	WTM3	WTM2	WTM1	WTM0

WTM7	Watch timer count clock selection (f_w)					
	$f_{SUB} = 32.768 \text{ kHz}$	$f_{PRS} = 2 \text{ MHz}$	$f_{PRS} = 5 \text{ MHz}$	$f_{PRS} = 10 \text{ MHz}$	$f_{PRS} = 20 \text{ MHz}$	
0	$f_{PRS}/2^7$	–	15.625 kHz	39.062 kHz	78.125 kHz	156.25 kHz
1	f_{SUB}	32.768 kHz	–			

WTM6	WTM5	WTM4	Prescaler interval time selection
0	0	0	$2^4/f_w$
0	0	1	$2^5/f_w$
0	1	0	$2^6/f_w$
0	1	1	$2^7/f_w$
1	0	0	$2^8/f_w$
1	0	1	$2^9/f_w$
1	1	0	$2^{10}/f_w$
1	1	1	$2^{11}/f_w$

WTM3	WTM2	Selection of watch timer interrupt time
0	0	$2^{14}/f_w$
0	1	$2^{13}/f_w$
1	0	$2^5/f_w$
1	1	$2^4/f_w$

WTM1	5-bit counter operation control
0	Clear after operation stop
1	Start

WTM0	Watch timer operation enable
0	Operation stop (clear both prescaler and 5-bit counter)
1	Operation enable

Caution Do not change the count clock and interval time (by setting bits 4 to 7 (WTM4 to WTM7) of WTM) during watch timer operation.

- Remarks**
1. f_w : Watch timer clock frequency ($f_{PRS}/2^7$ or f_{SUB})
 2. f_{PRS} : Peripheral hardware clock frequency
 3. f_{SUB} : Subsystem clock frequency

10.4 Watch Timer Operations

10.4.1 Watch timer operation

The watch timer generates an interrupt request signal (INTWT) at a specific time interval by using the peripheral hardware clock or subsystem clock.

When bit 0 (WTM0) and bit 1 (WTM1) of the watch timer operation mode register (WTM) are set to 1, the count operation starts. When these bits are cleared to 0, the 5-bit counter is cleared and the count operation stops.

When the interval timer is simultaneously operated, zero-second start can be achieved only for the watch timer by clearing WTM1 to 0. In this case, however, the 11-bit prescaler is not cleared. Therefore, an error up to $2^9 \times 1/f_w$ seconds occurs in the first overflow (INTWT) after zero-second start.

The interrupt request is generated at the following time intervals.

Table 10-4. Watch Timer Interrupt Time

WTM3	WTM2	Interrupt Time Selection	When Operated at $f_{SUB} = 32.768$ kHz (WTM7 = 1)	When Operated at $f_{PRS} = 2$ MHz (WTM7 = 0)	When Operated at $f_{PRS} = 5$ MHz (WTM7 = 0)	When Operated at $f_{PRS} = 10$ MHz (WTM7 = 0)	When Operated at $f_{PRS} = 20$ MHz (WTM7 = 0)
0	0	$2^{14}/f_w$	0.5 s	1.05 s	0.419 s	0.210 s	0.105 s
0	1	$2^{13}/f_w$	0.25 s	0.52 s	0.210 s	0.105 s	52.5 ms
1	0	$2^9/f_w$	977 μ s	2.05 ms	819 μ s	410 μ s	205 μ s
1	1	$2^7/f_w$	488 μ s	1.02 ms	410 μ s	205 μ s	102 μ s

- Remarks**
1. f_w : Watch timer clock frequency ($f_{PRS}/2^7$ or f_{SUB})
 2. f_{PRS} : Peripheral hardware clock frequency
 3. f_{SUB} : Subsystem clock frequency

10.4.2 Interval timer operation

The watch timer operates as interval timer which generates interrupt request signals (INTWTI) repeatedly at an interval of the preset count value.

The interval time can be selected with bits 4 to 6 (WTM4 to WTM6) of the watch timer operation mode register (WTM).

When bit 0 (WTM0) of the WTM is set to 1, the count operation starts. When this bit is set to 0, the count operation stops.

Table 10-5. Interval Timer Interval Time

WTM6	WTM5	WTM4	Interval Time	When Operated at $f_{SUB} = 32.768$ kHz (WTM7 = 1)	When Operated at $f_{PRS} = 2$ MHz (WTM7 = 0)	When Operated at $f_{PRS} = 5$ MHz (WTM7 = 0)	When Operated at $f_{PRS} = 10$ MHz (WTM7 = 0)	When Operated at $f_{PRS} = 20$ MHz (WTM7 = 0)
0	0	0	$2^4/f_w$	488 μ s	1.02 ms	410 μ s	205 μ s	102 μ s
0	0	1	$2^5/f_w$	977 μ s	2.05 ms	820 μ s	410 μ s	205 μ s
0	1	0	$2^6/f_w$	1.95 ms	4.10 ms	1.64 ms	820 μ s	410 μ s
0	1	1	$2^7/f_w$	3.91 ms	8.20 ms	3.28 ms	1.64 ms	820 μ s
1	0	0	$2^8/f_w$	7.81 ms	16.4 ms	6.55 ms	3.28 ms	1.64 ms
1	0	1	$2^9/f_w$	15.6 ms	32.8 ms	13.1 ms	6.55 ms	3.28 ms
1	1	0	$2^{10}/f_w$	31.3 ms	65.5 ms	26.2 ms	13.1 ms	6.55 ms
1	1	1	$2^{11}/f_w$	62.5 ms	131.1 ms	52.4 ms	26.2 ms	13.1 ms

- Remarks**
1. f_w : Watch timer clock frequency ($f_{PRS}/2^7$ or f_{SUB})
 2. f_{PRS} : Peripheral hardware clock frequency
 3. f_{SUB} : Subsystem clock frequency

Figure 10-3. Operation Timing of Watch Timer/Interval Timer

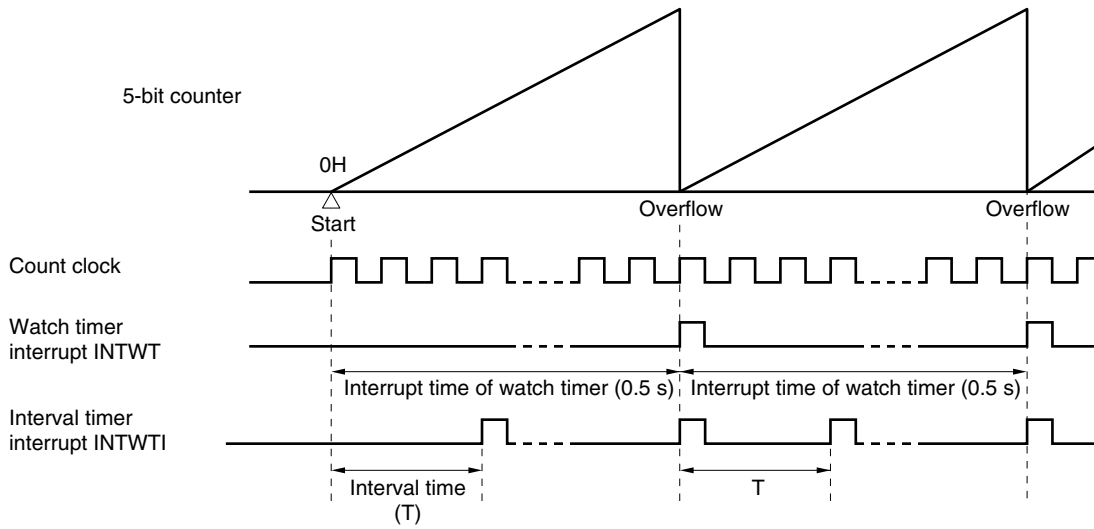

Remark fw: Watch timer clock frequency
 Figures in parentheses are for operation with fw = 32.768 kHz (WTM7 = 1, WTM3, WTM2 = 0, 0)

10.5 Cautions for Watch Timer

When operation of the watch timer and 5-bit counter is enabled by the watch timer mode control register (WTM) (by setting bits 0 (WTM0) and 1 (WTM1) of WTM to 1), the interval until the first interrupt request signal (INTWT) is generated after the register is set does not exactly match the specification made with bits 2 and 3 (WTM2, WTM3) of WTM. Subsequently, however, the INTWT signal is generated at the specified intervals.

Figure 10-4. Example of Generation of Watch Timer Interrupt Request Signal (INTWT) (When Interrupt Period = 0.5 s)

It takes 0.515625 seconds for the first INTWT to be generated ($2^9 \times 1/32768 = 0.015625$ s longer). INTWT is then generated every 0.5 seconds.

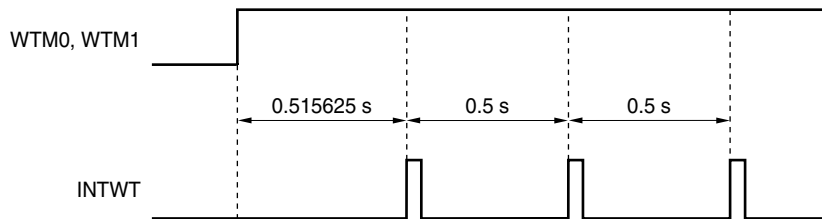

CHAPTER 11 WATCHDOG TIMER

11.1 Functions of Watchdog Timer

The watchdog timer operates on the internal low-speed oscillation clock.

The watchdog timer is used to detect an inadvertent program loop. If a program loop is detected, an internal reset signal is generated.

Program loop is detected in the following cases.

- If the watchdog timer counter overflows
- If a 1-bit manipulation instruction is executed on the watchdog timer enable register (WDTE)
- If data other than “ACH” is written to WDTE
- If data is written to WDTE during a window close period
- ★ • If the instruction is fetched from an area not set by the IMS and IXS registers (detection of an invalid check while the CPU hangs up)
- ★ • If the CPU accesses an area that is not set by the IMS and IXS registers (excluding FB00H to FFFFH) by executing a read/write instruction (detection of an abnormal access during a CPU program loop)

When a reset occurs due to the watchdog timer, bit 4 (WDTRF) of the reset control flag register (RESF) is set to 1. For details of RESF, see **CHAPTER 22 RESET FUNCTION**.

11.2 Configuration of Watchdog Timer

The watchdog timer includes the following hardware.

Table 11-1. Configuration of Watchdog Timer

Item	Configuration
Control register	Watchdog timer enable register (WDTE)

How the counter operation is controlled, overflow time, and window open period are set by the option byte.

Table 11-2. Setting of Option Bytes and Watchdog Timer

Setting of Watchdog Timer	Option Byte (0080H)
Window open period	Bits 6 and 5 (WINDOW1, WINDOW0)
Controlling counter operation of watchdog timer	Bit 4 (WDTON)
Overflow time of watchdog timer	Bits 3 to 1 (WDCS2 to WDCS0)

Remark For the option byte, see **CHAPTER 25 OPTION BYTE**.

Figure 11-1. Block Diagram of Watchdog Timer

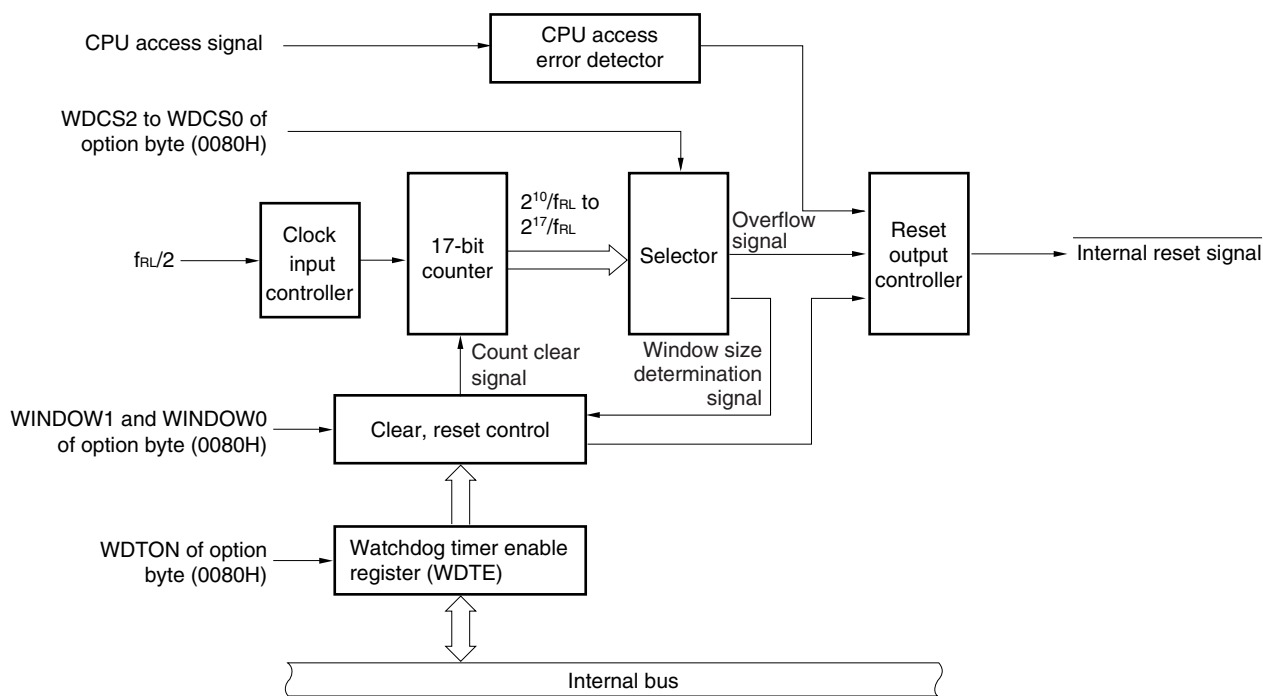

11.3 Register Controlling Watchdog Timer

The watchdog timer is controlled by the watchdog timer enable register (WDTE).

(1) Watchdog timer enable register (WDTE)

Writing ACH to WDTE clears the watchdog timer counter and starts counting again.

This register can be set by an 8-bit memory manipulation instruction.

Reset signal generation sets this register to 9AH or 1AH^{Note}.

Figure 11-2. Format of Watchdog Timer Enable Register (WDTE)

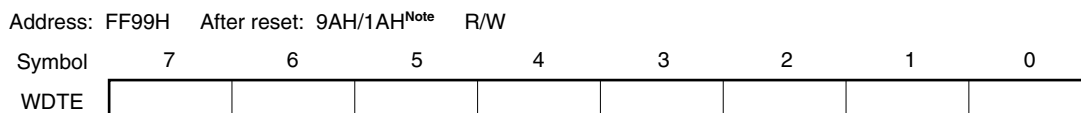

Note The WDTE reset value differs depending on the WDTON setting value of the option byte (0080H). To operate watchdog timer, set WDTON to 1.

WDTON Setting Value	WDTE Reset Value
0 (watchdog timer count operation disabled)	1AH
1 (watchdog timer count operation enabled)	9AH

- Cautions**
1. If a value other than ACH is written to WDTE, an internal reset signal is generated. If the source clock to the watchdog timer is stopped, however, an internal reset signal is generated when the source clock to the watchdog timer resumes operation.
 2. If a 1-bit memory manipulation instruction is executed for WDTE, an internal reset signal is generated. If the source clock to the watchdog timer is stopped, however, an internal reset signal is generated when the source clock to the watchdog timer resumes operation.
 3. The value read from WDTE is 9AH/1AH (this differs from the written value (ACH)).

11.4 Operation of Watchdog Timer

11.4.1 Controlling operation of watchdog timer

1. When the watchdog timer is used, its operation is specified by the option byte (0080H).
 - Enable counting operation of the watchdog timer by setting bit 4 (WDTON) of the option byte (0080H) to 1 (the counter starts operating after a reset release) (for details, see **CHAPTER 25**).

WDTON	Operation Control of Watchdog Timer Counter/Illegal Access Detection
0	Counter operation disabled (counting stopped after reset), illegal access detection operation disabled
1	Counter operation enabled (counting started after reset), illegal access detection operation enabled

- Set an overflow time by using bits 3 to 1 (WDCS2 to WDCS0) of the option byte (0080H) (for details, see **11.4.2** and **CHAPTER 25**).
 - Set a window open period by using bits 6 and 5 (WINDOW1 and WINDOW0) of the option byte (0080H) (for details, see **11.4.3** and **CHAPTER 25**).
2. After a reset release, the watchdog timer starts counting.
 3. By writing "ACH" to WDTE after the watchdog timer starts counting and before the overflow time set by the option byte, the watchdog timer is cleared and starts counting again.
 4. After that, write WDTE the second time or later after a reset release during the window open period. If WDTE is written during a window close period, an internal reset signal is generated.
 5. If the overflow time expires without "ACH" written to WDTE, an internal reset signal is generated.

★ A internal reset signal is generated in the following cases.

- If a 1-bit manipulation instruction is executed on the watchdog timer enable register (WDTE)
- If data other than "ACH" is written to WDTE
- If the instruction is fetched from an area not set by the IMS and IXS registers (detection of an invalid check during a CPU program loop)
- If the CPU accesses an area not set by the IMS and IXS registers (excluding FB00H to FFFFH) by executing a read/write instruction (detection of an abnormal access during a CPU program loop)

- Cautions**
1. **The first writing to WDTE after a reset release clears the watchdog timer, if it is made before the overflow time regardless of the timing of the writing, and the watchdog timer starts counting again.**
 2. **If the watchdog timer is cleared by writing "ACH" to WDTE, the actual overflow time may be different from the overflow time set by the option byte by up to 2/f_RL seconds.**
 3. **The watchdog timer can be cleared immediately before the count value overflows (FFFFH).**

Cautions 4. The operation of the watchdog timer in the HALT and STOP modes differs as follows depending on the set value of bit 0 (LSROSC) of the option byte.

	LSROSC = 0 (Internal Low-Speed Oscillator Can Be Stopped by Software)	LSROSC = 1 (Internal Low-Speed Oscillator Cannot Be Stopped)
In HALT mode	Watchdog timer operation stops.	Watchdog timer operation continues.
In STOP mode		

If LSROSC = 0, the watchdog timer resumes counting after the HALT or STOP mode is released. At this time, the counter is not cleared to 0 but starts counting from the value at which it was stopped.

★ If oscillation of the internal low-speed oscillator is stopped by setting LSRSTOP (bit 1 of the internal oscillation mode register (RCM) = 1) when LSROSC = 0, the watchdog timer stops operating. At this time, the counter is not cleared to 0.

5. The watchdog timer does not stop during self-programming of the flash memory and EEPROM™ emulation. During processing, the interrupt acknowledge time is delayed. Set the overflow time and window size taking this delay into consideration.

11.4.2 Setting overflow time of watchdog timer

Set the overflow time of the watchdog timer by using bits 3 to 1 (WDCS2 to WDCS0) of the option byte (0080H).

If an overflow occurs, an internal reset signal is generated. The present count is cleared and the watchdog timer starts counting again by writing “ACH” to WDTE during the window open period before the overflow time.

The following overflow time is set.

Table 11-3. Setting of Overflow Time of Watchdog Timer

WDCS2	WDCS1	WDCS0	Overflow Time of Watchdog Timer
0	0	0	$2^{10}/f_{RL}$ (3.88 ms)
0	0	1	$2^{11}/f_{RL}$ (7.76 ms)
0	1	0	$2^{12}/f_{RL}$ (15.52 ms)
0	1	1	$2^{13}/f_{RL}$ (31.03 ms)
1	0	0	$2^{14}/f_{RL}$ (62.06 ms)
1	0	1	$2^{15}/f_{RL}$ (124.12 ms)
1	1	0	$2^{16}/f_{RL}$ (248.24 ms)
1	1	1	$2^{17}/f_{RL}$ (496.48 ms)

Cautions 1. The combination of WDCS2 = WDCS1 = WDCS0 = 0 and WINDOW1 = WINDOW0 = 0 is prohibited.

2. The watchdog timer does not stop during self-programming of the flash memory and EEPROM emulation. During processing, the interrupt acknowledge time is delayed. Set the overflow time and window size taking this delay into consideration.

Remarks 1. f_{RL} : Internal low-speed oscillation clock frequency
 2. (): $f_{RL} = 264$ kHz (MAX.)

11.4.3 Setting window open period of watchdog timer

Set the window open period of the watchdog timer by using bits 6 and 5 (WINDOW1, WINDOW0) of the option byte (0080H). The outline of the window is as follows.

- If “ACH” is written to WDTE during the window open period, the watchdog timer is cleared and starts counting again.
- Even if “ACH” is written to WDTE during the window close period, an abnormality is detected and an internal reset signal is generated.

Example: If the window open period is 25%

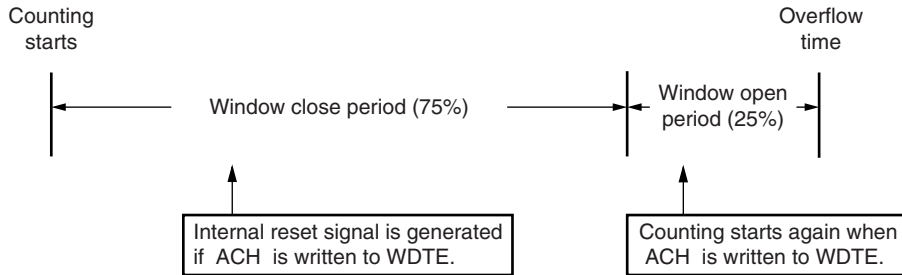

Caution The first writing to WDTE after a reset release clears the watchdog timer, if it is made before the overflow time regardless of the timing of the writing, and the watchdog timer starts counting again.

The window open period to be set is as follows.

Table 11-4. Setting Window Open Period of Watchdog Timer

WINDOW1	WINDOW0	Window Open Period of Watchdog Timer
0	0	25%
0	1	50%
1	0	75%
1	1	100%

- Cautions**
1. The combination of WDCS2 = WDCS1 = WDCS0 = 0 and WINDOW1 = WINDOW0 = 0 is prohibited.
 2. The watchdog timer does not stop during self-programming of the flash memory and EEPROM emulation. During processing, the interrupt acknowledge time is delayed. Set the overflow time and window size taking this delay into consideration.

Remark If the overflow time is set to $2^{10}/f_{RL}$, the window close time and open time are as follows.

	Setting of Window Open Period			
	25%	50%	75%	100%
Window close time	0 to 3.56 ms	0 to 2.37 ms	0 to 0.119 ms	None
Window open time	3.56 to 3.88 ms	2.37 to 3.88 ms	0.119 to 3.88 ms	0 to 3.88 ms

<When window open period is 25%>

- Overflow time:
 $2^{10}/f_{RL} \text{ (MAX.)} = 2^{10}/264 \text{ kHz (MAX.)} = 3.88 \text{ ms}$
- Window close time:
 $0 \text{ to } 2^{10}/f_{RL} \text{ (MIN.)} \times (1 - 0.25) = 0 \text{ to } 2^{10}/216 \text{ kHz (MIN.)} \times 0.75 = 0 \text{ to } 3.56 \text{ ms}$
- Window open time:
 $2^{10}/f_{RL} \text{ (MIN.)} \times (1 - 0.25) \text{ to } 2^{10}/f_{RL} \text{ (MAX.)} = 2^{10}/216 \text{ kHz (MIN.)} \times 0.75 \text{ to } 2^{10}/264 \text{ kHz (MAX.)}$
 $= 3.56 \text{ to } 3.88 \text{ ms}$

CHAPTER 12 CLOCK OUTPUT/BUZZER OUTPUT CONTROLLER

12.1 Functions of Clock Output/Buzzer Output Controller

The clock output controller is intended for carrier output during remote controlled transmission and clock output for supply to peripheral ICs. The clock selected with the clock output selection register (CKS) is output.

In addition, the buzzer output is intended for square-wave output of buzzer frequency selected with CKS.

Figure 12-1 shows the block diagram of clock output/buzzer output controller.

Figure 12-1. Block Diagram of Clock Output/Buzzer Output Controller

12.2 Configuration of Clock Output/Buzzer Output Controller

The clock output/buzzer output controller includes the following hardware.

Table 12-1. Configuration of Clock Output/Buzzer Output Controller

Item	Configuration
Control registers	Clock output selection register (CKS) Port mode register 14 (PM14) Port register 14 (P14)

12.3 Registers Controlling Clock Output/Buzzer Output Controller

The following two registers are used to control the clock output/buzzer output controller.

- Clock output selection register (CKS)
- Port mode register 14 (PM14)

(1) Clock output selection register (CKS)

This register sets output enable/disable for clock output (PCL) and for the buzzer frequency output (BUZ), and sets the output clock.

CKS is set by a 1-bit or 8-bit memory manipulation instruction.

Reset signal generation sets CKS to 00H.

Figure 12-2. Format of Clock Output Selection Register (CKS)

Address: FF40H After reset: 00H R/W

Symbol	<7>	6	5	<4>	3	2	1	0
CKS	BZOE	BCS1	BCS0	CLOE	CCS3	CCS2	CCS1	CCS0

BZOE	BUZ output enable/disable specification
0	Clock division circuit operation stopped. BUZ fixed to low level.
1	Clock division circuit operation enabled. BUZ output enabled.

BCS1	BCS0	BUZ output clock selection		
			f _{PRS} = 10 MHz	f _{PRS} = 20 MHz
0	0	f _{PRS} /2 ¹⁰	9.77 kHz	19.54 kHz
0	1	f _{PRS} /2 ¹¹	4.88 kHz	9.77 kHz
1	0	f _{PRS} /2 ¹²	2.44 kHz	4.88 kHz
1	1	f _{PRS} /2 ¹³	1.22 kHz	2.44 kHz

CLOE	PCL output enable/disable specification
0	Clock division circuit operation stopped. PCL fixed to low level.
1	Clock division circuit operation enabled. PCL output enabled.

CCS3	CCS2	CCS1	CCS0	f _{PRS}	PCL output clock selection		
					f _{SUB} = 32.768 kHz	f _{PRS} = 10 MHz	f _{PRS} = 20 MHz
0	0	0	0	f _{PRS} ^{Note 1}	–	10 MHz	Setting prohibited ^{Note 2}
0	0	0	1	f _{PRS} /2		5 MHz	10 MHz
0	0	1	0	f _{PRS} /2 ²		2.5 MHz	5 MHz
0	0	1	1	f _{PRS} /2 ³		1.25 MHz	2.5 MHz
0	1	0	0	f _{PRS} /2 ⁴		625 kHz	1.25 MHz
0	1	0	1	f _{PRS} /2 ⁵		312.5 kHz	625 kHz
0	1	1	0	f _{PRS} /2 ⁶		156.25 kHz	312.5 kHz
0	1	1	1	f _{PRS} /2 ⁷		78.125 kHz	156.25 kHz
1	0	0	0	f _{SUB}	32.768 kHz		–
Other than above					Setting prohibited		

- ★ **Notes 1.** If the peripheral hardware clock operates on the internal high-speed oscillation clock when 1.8 V ≤ V_{DD} < 2.7 V, setting CCS3 = CCS2 = CCS1 = CCS0 = 0 (output clock of PCL: f_{PRS}) is prohibited.
- 2. The PCL output clock prohibits settings if they exceed 10 MHz.

- ★ **Cautions 1.** Set BCS1 and BCS0 when the buzzer output operation is stopped (BZOE = 0).
- ★ **2.** Set CCS3 to CCS0 while the clock output operation is stopped (CLOE = 0).

- Remarks 1.** f_{PRS}: Peripheral hardware clock frequency
2. f_{SUB}: Subsystem clock frequency

(2) Port mode register 14 (PM14)

This register sets port 14 input/output in 1-bit units.

When using the P140/INTP6/PCL pin for clock output and the P141/INTP7/BUZ pin for buzzer output, clear PM140 and PM141 and the output latches of P140 and P141 to 0.

PM14 is set by a 1-bit or 8-bit memory manipulation instruction.

Reset signal generation sets PM14 to FFH.

Figure 12-3. Format of Port Mode Register 14 (PM14)

Address: FF2EH After reset: FFH R/W

Symbol	7	6	5	4	3	2	1	0
PM14	1	1	1	1	1	1	PM141	PM140

PM14n	P14n pin I/O mode selection (n = 0, 1)
0	Output mode (output buffer on)
1	Input mode (output buffer off)

12.4 Operations of Clock Output/Buzzer Output Controller

12.4.1 Operation as clock output

The clock pulse is output as the following procedure.

- <1> Select the clock pulse output frequency with bits 0 to 3 (CCS0 to CCS3) of the clock output selection register (CKS) (clock pulse output in disabled status).
- <2> Set bit 4 (CLOE) of CKS to 1 to enable clock output.

Remark The clock output controller is designed not to output pulses with a small width during output enable/disable switching of the clock output. As shown in Figure 12-4, be sure to start output from the low period of the clock (marked with * in the figure). When stopping output, do so after the high-level period of the clock.

Figure 12-4. Remote Control Output Application Example

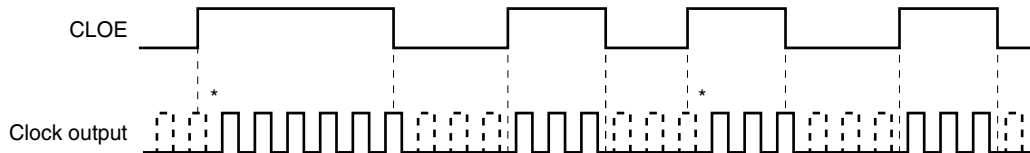

12.4.2 Operation as buzzer output

The buzzer frequency is output as the following procedure.

- <1> Select the buzzer output frequency with bits 5 and 6 (BCS0, BCS1) of the clock output selection register (CKS) (buzzer output in disabled status).
- <2> Set bit 7 (BZOE) of CKS to 1 to enable buzzer output.

CHAPTER 13 A/D CONVERTER

13.1 Function of A/D Converter

The A/D converter converts an analog input signal into a digital value, and consists of up to eight channels (ANI0 to ANI7) with a resolution of 10 bits.

The A/D converter has the following function.

- **10-bit resolution A/D conversion**

10-bit resolution A/D conversion is carried out repeatedly for one analog input channel selected from ANI0 to ANI7. Each time an A/D conversion operation ends, an interrupt request (INTAD) is generated.

Figure 13-1. Block Diagram of A/D Converter

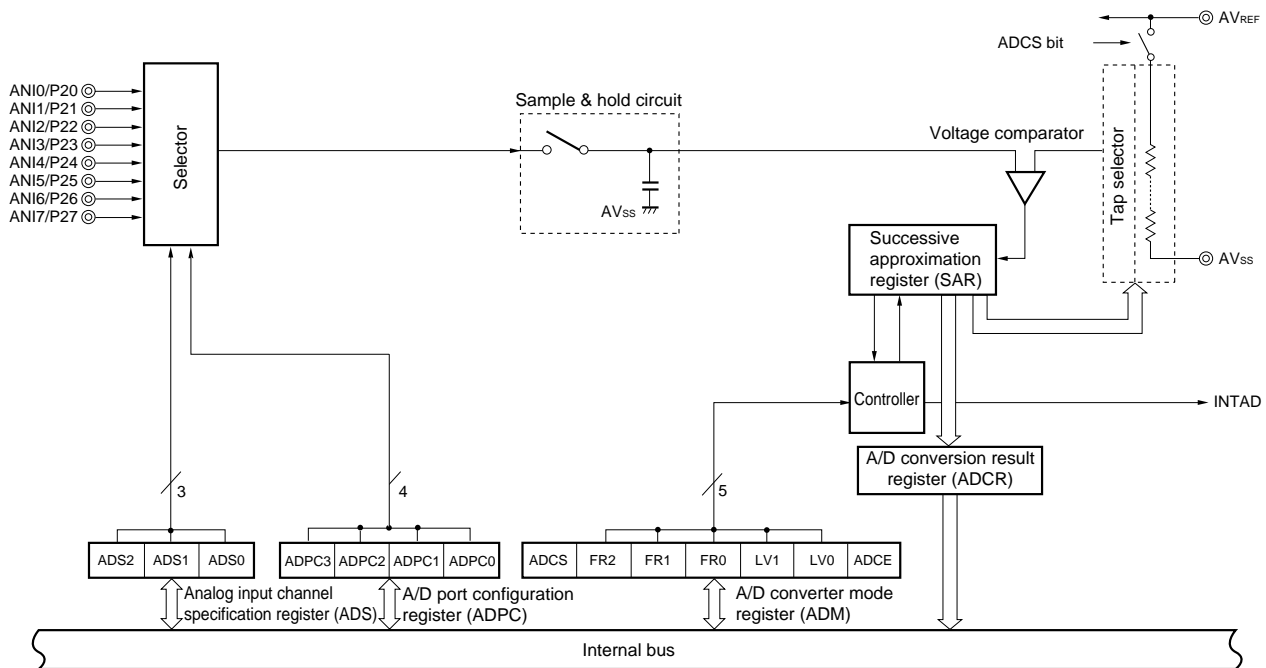

13.2 Configuration of A/D Converter

The A/D converter includes the following hardware.

(1) ANI0 to ANI7 pins

These are the analog input pins of the 8-channel A/D converter. They input analog signals to be converted into digital signals. Pins other than the one selected as the analog input pin can be used as I/O port pins.

(2) Sample & hold circuit

- ★ The sample & hold circuit samples the input voltage of the analog input pin selected by the selector when A/D conversion is started, and holds the sampled voltage value during A/D conversion.

(3) Series resistor string

- ★ The series resistor string is connected between AV_{REF} and AV_{SS} , and generates a voltage to be compared with the sampled voltage value.

Figure 13-2. Circuit Configuration of Series Resistor String

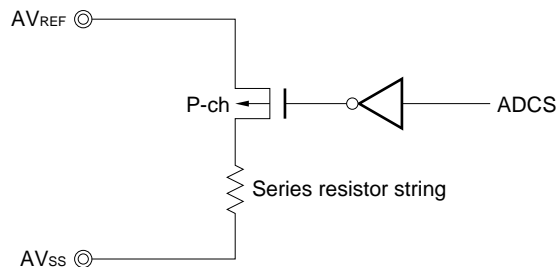

(4) Voltage comparator

The voltage comparator compares the sampled voltage value and the output voltage of the series resistor string.

(5) Successive approximation register (SAR)

- ★ This register converts the result of comparison by the voltage comparator, starting from the most significant bit (MSB).

When the voltage value is converted into a digital value down to the least significant bit (LSB) (end of A/D conversion), the contents of the SAR register are transferred to the A/D conversion result register (ADCR).

(6) 10-bit A/D conversion result register (ADCR)

The A/D conversion result is loaded from the successive approximation register to this register each time A/D conversion is completed, and the ADCR register holds the A/D conversion result in its higher 10 bits (the lower 6 bits are fixed to 0).

(7) 8-bit A/D conversion result register (ADCRH)

The A/D conversion result is loaded from the successive approximation register to this register each time A/D conversion is completed, and the ADCRH register stores the higher 8 bits of the A/D conversion result.

Caution When data is read from ADCR and ADCRH, a wait cycle is generated. Do not read data from ADCR and ADCRH when the CPU is operating on the subsystem clock and the peripheral hardware clock is stopped. For details, see CHAPTER 31 CAUTIONS FOR WAIT.

(8) Controller

This circuit controls the conversion time of an input analog signal that is to be converted into a digital signal, as well as starting and stopping of the conversion operation. When A/D conversion has been completed, this controller generates INTAD.

(9) AV_{REF} pin

- ★ This pin inputs an analog power/reference voltage to the A/D converter. Make this pin the same potential as the V_{DD} pin when port 2 is used as a digital port.

The signal input to ANI0 to ANI7 is converted into a digital signal, based on the voltage applied across AV_{REF} and AV_{SS}.

(10) AV_{SS} pin

This is the ground potential pin of the A/D converter. Always use this pin at the same potential as that of the V_{SS} pin even when the A/D converter is not used.

(11) A/D converter mode register (ADM)

This register is used to set the conversion time of the analog input signal to be converted, and to start or stop the conversion operation.

(12) A/D port configuration register (ADPC)

This register switches the ANI0/P20 to ANI7/P27 pins to analog input of A/D converter or digital I/O of port.

(13) Analog input channel specification register (ADS)

This register is used to specify the port that inputs the analog voltage to be converted into a digital signal.

(14) Port mode register 2 (PM2)

This register switches the ANI0/P20 to ANI7/P27 pins to input or output.

13.3 Registers Used in A/D Converter

The A/D converter uses the following six registers.

- A/D converter mode register (ADM)
- A/D port configuration register (ADPC)
- Analog input channel specification register (ADS)
- Port mode register 2 (PM2)
- 10-bit A/D conversion result register (ADCR)
- 8-bit A/D conversion result register (ADCRH)

(1) A/D converter mode register (ADM)

This register sets the conversion time for analog input to be A/D converted, and starts/stops conversion. ADM can be set by a 1-bit or 8-bit memory manipulation instruction. Reset signal generation sets this register to 00H.

Figure 13-3. Format of A/D Converter Mode Register (ADM)

Address: FF28H After reset: 00H R/W

Symbol	<7>	6	5	4	3	2	1	<0>
ADM	ADCS	0	FR2 ^{Note 1}	FR1 ^{Note 1}	FR0 ^{Note 1}	LV1 ^{Note 1}	LV0 ^{Note 1}	ADCE

ADCS	A/D conversion operation control
0	Stops conversion operation
1	Enables conversion operation

ADCE	Comparator operation control ^{Note 2}
0	Stops comparator operation
1	Enables comparator operation (comparator: 1/2AV _{REF} operation)

- Notes**
1. For details of FR2 to FR0, LV1, LV0, and A/D conversion, see **Table 13-2 A/D Conversion Time Selection**.
 2. The operation of the comparator is controlled by ADCS and ADCE, and it takes 1 μ s from operation start to operation stabilization. Therefore, when ADCS is set to 1 after 1 μ s or more has elapsed from the time ADCE is set to 1, the conversion result at that time has priority over the first conversion result. Otherwise, ignore data of the first conversion.

Table 13-1. Settings of ADCS and ADCE

ADCS	ADCE	A/D Conversion Operation
0	0	Stop status (DC power consumption path does not exist)
0	1	Conversion waiting mode (comparator: 1/2AV _{REF} operation, only comparator consumes power)
1	0	Conversion mode (comparator operation stopped ^{Note 2})
1	1	Conversion mode (comparator: 1/2AV _{REF} operation)

Note Ignore data of the first conversion because it is not guaranteed range.

Figure 13-4. Timing Chart When Comparator Is Used

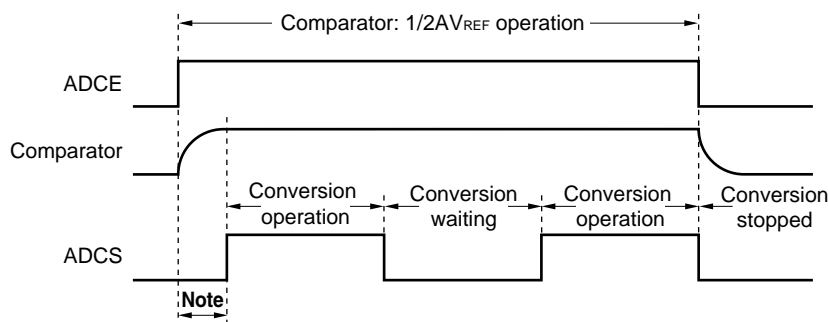

Note To stabilize the internal circuit, the time from the rising of the ADCE bit to the falling of the ADCS bit must be $1 \mu\text{s}$ or longer.

- Cautions**
1. A/D conversion must be stopped before rewriting bits FR0 to FR2, LV1, and LV0 to values other than the identical data.
 2. If data is written to ADM, a wait cycle is generated. Do not write data to ADM when the CPU is operating on the subsystem clock and the peripheral hardware clock is stopped. For details, see CHAPTER 31 CAUTIONS FOR WAIT.

Table 13-2. A/D Conversion Time Selection

(1) $2.7\text{ V} \leq AV_{REF} \leq 5.5\text{ V}$

A/D Converter Mode Register (ADM)					Conversion Time Selection			Conversion Clock (f_{AD})	Conversion Time Configuration				
FR2	FR1	FR0	LV1	LV0	$f_{PRS} = 2\text{ MHz}$	$f_{PRS} = 10\text{ MHz}$	$f_{PRS} = 20\text{ MHz}^{Note}$		SAR Clear	Sampling	Successive Conversion Time	ADCR Transfer, INTAD Generation	
0	0	0	0	0	$264/f_{PRS}$	Setting	$26.4\ \mu\text{s}$	$13.2\ \mu\text{s}^{Note}$	$f_{PRS}/12$	$2/f_{AD}$	$6/f_{AD}$	$12/f_{AD}$	$2/f_{AD}$
0	0	1	0	0	$176/f_{PRS}$	prohibited	$17.6\ \mu\text{s}$	$8.8\ \mu\text{s}^{Note}$	$f_{PRS}/8$				
0	1	0	0	0	$132/f_{PRS}$		$13.2\ \mu\text{s}$	$6.6\ \mu\text{s}^{Note}$	$f_{PRS}/6$				
0	1	1	0	0	$88/f_{PRS}$		$8.8\ \mu\text{s}^{Note}$	Setting	$f_{PRS}/4$				
1	0	0	0	0	$66/f_{PRS}$		$33.0\ \mu\text{s}$		$6.6\ \mu\text{s}^{Note}$				
1	0	1	0	0	$44/f_{PRS}$	$22.0\ \mu\text{s}$	Setting prohibited	$f_{PRS}/2$					
Other than above					Setting prohibited								

Note This can be set only when $4.0\text{ V} \leq AV_{REF} \leq 5.5\text{ V}$.

(2) $2.3\text{ V} \leq AV_{REF} < 2.7\text{ V}$

A/D Converter Mode Register (ADM)					Conversion Time Selection		Conversion Clock (f_{AD})	Conversion Time Configuration						
FR2	FR1	FR0	LV1	LV0	$f_{PRS} = 2\text{ MHz}$	$f_{PRS} = 5\text{ MHz}$		SAR Clear	Sampling	Successive Conversion Time	ADCR Transfer, INTAD Generation			
0	0	0	0	1	$480/f_{PRS}$	Setting prohibited	Setting prohibited	$f_{PRS}/12$	$2/f_{AD}$	$24/f_{AD}$	$12/f_{AD}$	$2/f_{AD}$		
0	0	1	0	1	$320/f_{PRS}$								$64.0\ \mu\text{s}$	$f_{PRS}/8$
0	1	0	0	1	$240/f_{PRS}$								$48.0\ \mu\text{s}$	$f_{PRS}/6$
0	1	1	0	1	$160/f_{PRS}$								$32.0\ \mu\text{s}$	$f_{PRS}/4$
1	0	0	0	1	$120/f_{PRS}$	$60.0\ \mu\text{s}$	Setting prohibited	$f_{PRS}/3$						
1	0	1	0	1	$80/f_{PRS}$	$40.0\ \mu\text{s}$	Setting prohibited	$f_{PRS}/2$						
Other than above					Setting prohibited									

- ★ **Cautions**
1. **Set the conversion times with the following conditions.**
 - $4.0\text{ V} \leq AV_{REF} \leq 5.5\text{ V}$: Sampling + successive conversion time = 5 to 30 μs ($f_{AD} = 0.6$ to 3.6 MHz)
 - $2.7\text{ V} \leq AV_{REF} < 4.0\text{ V}$: Sampling + successive conversion time = 10 to 30 μs ($f_{AD} = 0.6$ to 1.8 MHz)
 - $2.3\text{ V} \leq AV_{REF} < 2.7\text{ V}$: Sampling + successive conversion time = 25 to 62 μs ($f_{AD} = 0.6$ to 1.48 MHz)
 2. When rewriting FR2 to FR0, LV1, and LV0 to other than the same data, stop A/D conversion once (ADCS = 0) beforehand.
 3. Change LV1 and LV0 from the default value, when $2.3\text{ V} \leq AV_{REF} < 2.7\text{ V}$.
- ★
4. The above conversion time does not include clock frequency errors. Select conversion time, taking clock frequency errors into consideration.

Remark f_{PRS} : Peripheral hardware clock frequency

Figure 13-5. A/D Converter Sampling and A/D Conversion Timing

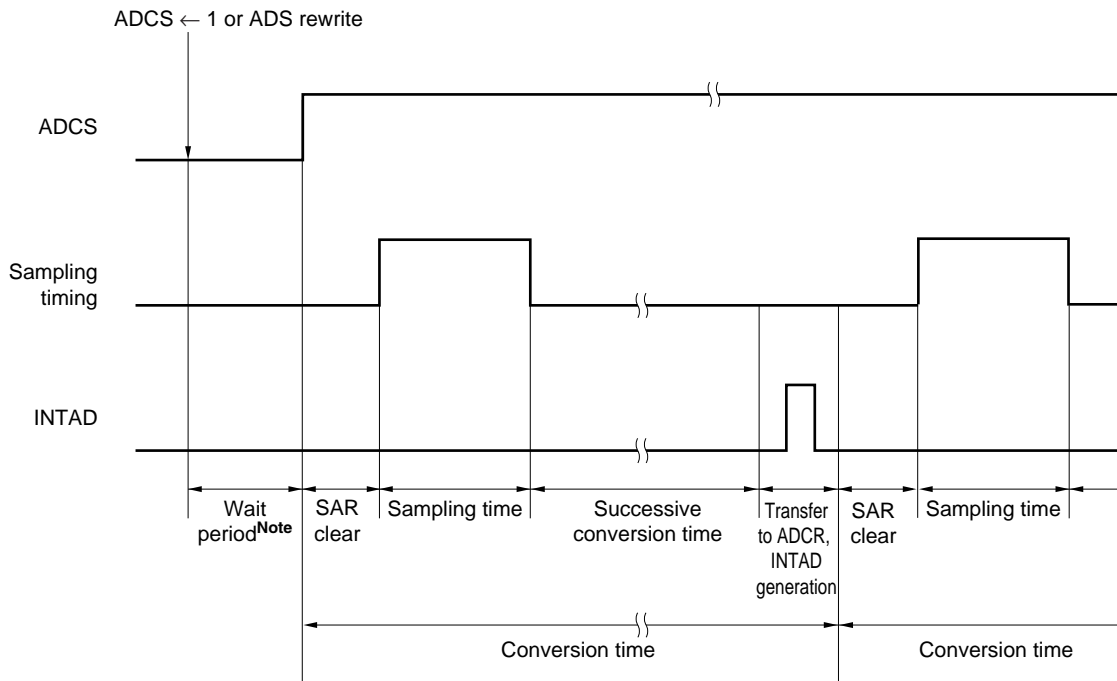

Note For details of wait period, see **CHAPTER 31 CAUTIONS FOR WAIT**.

(2) 10-bit A/D conversion result register (ADCR)

This register is a 16-bit register that stores the A/D conversion result. The lower 6 bits are fixed to 0. Each time A/D conversion ends, the conversion result is loaded from the successive approximation register. The higher 8 bits of the conversion result are stored in FF09H and the lower 2 bits are stored in the higher 2 bits of FF08H. ADCR can be read by a 16-bit memory manipulation instruction. Reset signal generation sets this register to 0000H.

Figure 13-6. Format of 10-Bit A/D Conversion Result Register (ADCR)

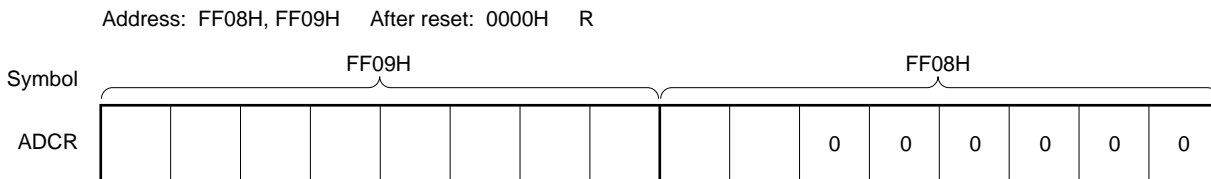

- Cautions**
1. When writing to the A/D converter mode register (ADM), analog input channel specification register (ADS), and A/D port configuration register (ADPC), the contents of ADCR may become undefined. Read the conversion result following conversion completion before writing to ADM, ADS, and ADPC. Using timing other than the above may cause an incorrect conversion result to be read.
 2. If data is read from ADCR, a wait cycle is generated. Do not read data from ADCR when the CPU is operating on the subsystem clock and the peripheral hardware clock is stopped. For details, see **CHAPTER 31 CAUTIONS FOR WAIT**.

(3) 8-bit A/D conversion result register (ADCRH)

This register is an 8-bit register that stores the A/D conversion result. The higher 8 bits of 10-bit resolution are stored.

ADCRH can be read by an 8-bit memory manipulation instruction.

Reset signal generation sets this register to 00H.

Figure 13-7. Format of 8-Bit A/D Conversion Result Register (ADCRH)

Address: FF09H After reset: 00H R

Symbol	7	6	5	4	3	2	1	0
ADCRH								

- Cautions**
1. When writing to the A/D converter mode register (ADM), analog input channel specification register (ADS), and A/D port configuration register (ADPC), the contents of ADCRH may become undefined. Read the conversion result following conversion completion before writing to ADM, ADS, and ADPC. Using timing other than the above may cause an incorrect conversion result to be read.
 2. If data is read from ADCRH, a wait cycle is generated. Do not read data from ADCRH when the CPU is operating on the subsystem clock and the peripheral hardware clock is stopped. For details, see CHAPTER 31 CAUTIONS FOR WAIT.

(4) Analog input channel specification register (ADS)

This register specifies the input channel of the analog voltage to be A/D converted.

ADS can be set by a 1-bit or 8-bit memory manipulation instruction.

Reset signal generation sets this register to 00H.

Figure 13-8. Format of Analog Input Channel Specification Register (ADS)

Address: FF29H After reset: 00H R/W

Symbol	7	6	5	4	3	2	1	0
ADS	0	0	0	0	0	ADS2	ADS1	ADS0

ADS2	ADS1	ADS0	Analog input channel specification
0	0	0	ANI0
0	0	1	ANI1
0	1	0	ANI2
0	1	1	ANI3
1	0	0	ANI4
1	0	1	ANI5
1	1	0	ANI6
1	1	1	ANI7

Cautions 1. Be sure to clear bits 3 to 7 to 0.

- ★ **2 Set a channel to be used for A/D conversion in the input mode by using port mode register 2 (PM2).**
- ★ **3. Do not set a pin to be used as a digital I/O pin with ADPC with ADS.**
- 4. If data is written to ADS, a wait cycle is generated. Do not write data to ADS when the CPU is operating on the subsystem clock and the peripheral hardware clock is stopped. For details, see CHAPTER 31 CAUTIONS FOR WAIT.**

(5) A/D port configuration register (ADPC)

- ★ This register switches the ANI0/P20 to ANI7/P27 pins to analog input of A/D converter or digital I/O of port. ADPC can be set by a 1-bit or 8-bit memory manipulation instruction. Reset signal generation sets this register to 00H.

Figure 13-9. Format of A/D Port Configuration Register (ADPC)

Address: FF2FH After reset: 00H R/W

Symbol	7	6	5	4	3	2	1	0
ADPC	0	0	0	0	ADPC3	ADPC2	ADPC1	ADPC0

ADPC3	ADPC2	ADPC1	ADPC0	Analog input (A)/digital I/O (D) switching							
				ANI7/ P27	ANI6/ P26	ANI5/ P25	ANI4/ P24	ANI3/ P23	ANI2/ P22	ANI1/ P21	ANI0/ P20
0	0	0	0	A	A	A	A	A	A	A	A
0	0	0	1	A	A	A	A	A	A	A	D
0	0	1	0	A	A	A	A	A	A	D	D
0	0	1	1	A	A	A	A	A	D	D	D
0	1	0	0	A	A	A	A	D	D	D	D
0	1	0	1	A	A	A	D	D	D	D	D
0	1	1	0	A	A	D	D	D	D	D	D
0	1	1	1	A	D	D	D	D	D	D	D
1	0	0	0	D	D	D	D	D	D	D	D
Other than above				Setting prohibited							

- ★ **Cautions** 1. Set a channel to be used for A/D conversion in the input mode by using port mode register 2 (PM2).
- ★ 2. Do not set a pin to be used as a digital I/O pin with ADPC with ADS.
- 3. If data is written to ADPC, a wait cycle is generated. Do not write data to ADPC when the CPU is operating on the subsystem clock and the peripheral hardware clock is stopped. For details, see CHAPTER 31 CAUTIONS FOR WAIT.

(6) Port mode register 2 (PM2)

When using the ANI0/P20 to ANI7/P27 pins for analog input port, set PM20 to PM27 to 1. The output latches of P20 to P27 at this time may be 0 or 1.

If PM20 to PM27 are set to 0, they cannot be used as analog input port pins.

PM2 can be set by a 1-bit or 8-bit memory manipulation instruction.

Reset signal generation sets this register to FFH.

Figure 13-10. Format of Port Mode Register 2 (PM2)

Address: FF22H After reset: FFH R/W

Symbol	7	6	5	4	3	2	1	0
PM2	PM27	PM26	PM25	PM24	PM23	PM22	PM21	PM20

PM2n	P2n pin I/O mode selection (n = 0 to 7)
0	Output mode (output buffer on)
1	Input mode (output buffer off)

ANI0/P20 to ANI7/P27 pins are as shown below depending on the settings of ADPC, ADS, and PM2.

★

Table 13-3. Setting Functions of ANI0/P20 to ANI7/P27 Pins

ADPC	PM2	ADS	ANI0/P20 to ANI7/P27 Pin
Analog input selection	Input mode	Selects ANI.	Analog input (to be converted)
		Does not select ANI.	Analog input (not to be converted)
	Output mode	Selects ANI.	Setting prohibited
		Does not select ANI.	
Digital I/O selection	Input mode	Selects ANI.	Setting prohibited
		Does not select ANI.	Digital input
	Output mode	Selects ANI.	Setting prohibited
		Does not select ANI.	Digital output

13.4 A/D Converter Operations

★ 13.4.1 Basic operations of A/D converter

- <1> Set bit 0 (ADCE) of the A/D converter mode register (ADM) to 1 to start the operation of the comparator.
- <2> Set channels for A/D conversion to analog input by using the A/D port configuration register (ADPC) and set to input mode by using port mode register 2 (PM2).
- <3> Set A/D conversion time by using bits 5 to 1 (FR2 to FR0, LV1, and LV0) of ADM.
- <4> Select one channel for A/D conversion using the analog input channel specification register (ADS).
- <5> Start the conversion operation by setting bit 7 (ADCS) of ADM to 1.
(<6> to <12> are operations performed by hardware.)
- <6> The voltage input to the selected analog input channel is sampled by the sample & hold circuit.
- <7> When sampling has been done for a certain time, the sample & hold circuit is placed in the hold state and the sampled voltage is held until the A/D conversion operation has ended.
- <8> Bit 9 of the successive approximation register (SAR) is set. The series resistor string voltage tap is set to $(1/2) AV_{REF}$ by the tap selector.
- <9> The voltage difference between the series resistor string voltage tap and sampled voltage is compared by the voltage comparator. If the analog input is greater than $(1/2) AV_{REF}$, the MSB of SAR remains set to 1. If the analog input is smaller than $(1/2) AV_{REF}$, the MSB is reset to 0.
- <10> Next, bit 8 of SAR is automatically set to 1, and the operation proceeds to the next comparison. The series resistor string voltage tap is selected according to the preset value of bit 9, as described below.
 - Bit 9 = 1: $(3/4) AV_{REF}$
 - Bit 9 = 0: $(1/4) AV_{REF}$
 The voltage tap and sampled voltage are compared and bit 8 of SAR is manipulated as follows.
 - Analog input voltage \geq Voltage tap: Bit 8 = 1
 - Analog input voltage $<$ Voltage tap: Bit 8 = 0
- <11> Comparison is continued in this way up to bit 0 of SAR.
- <12> Upon completion of the comparison of 10 bits, an effective digital result value remains in SAR, and the result value is transferred to the A/D conversion result register (ADCR, ADCRH) and then latched.
At the same time, the A/D conversion end interrupt request (INTAD) can also be generated.
- <13> Repeat steps <6> to <12>, until ADCS is cleared to 0.
To stop the A/D converter, clear ADCS to 0.
To restart A/D conversion from the status of ADCE = 1, start from <5>. To start A/D conversion again when ADCE = 0, set ADCE to 1, wait for 1 μ s or longer, and start <5>. To change a channel of A/D conversion, start from <4>.

Caution Make sure the period of <1> to <5> is 1 μ s or more.

Remark Two types of A/D conversion result registers are available.

- ADCR (16 bits): Store 10-bit A/D conversion value
- ADCRH (8 bits): Store 8-bit A/D conversion value

Figure 13-11. Basic Operation of A/D Converter

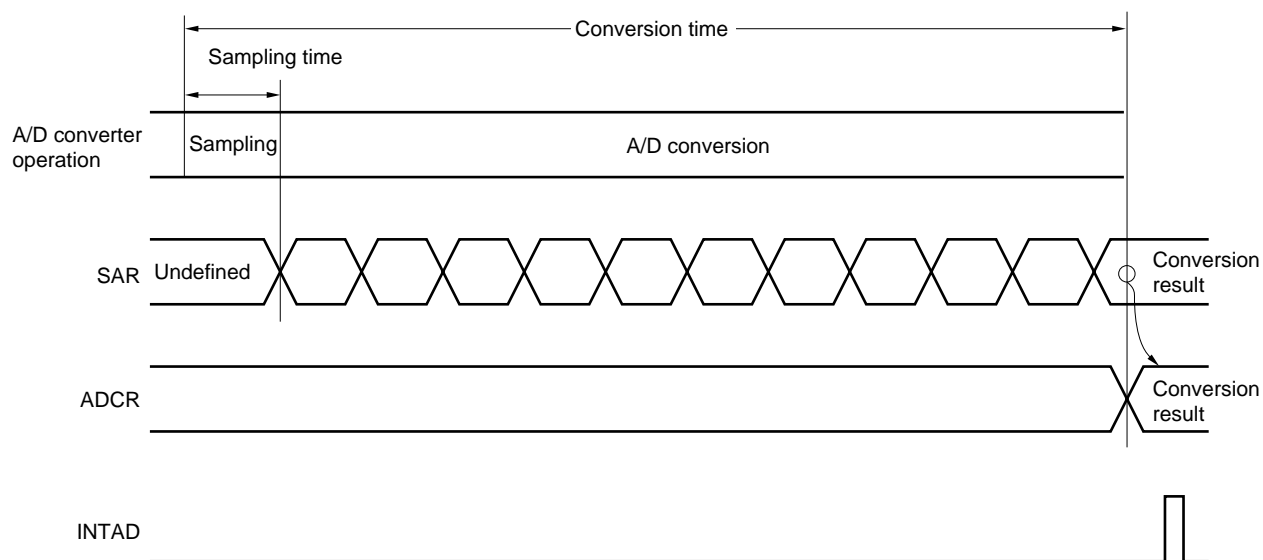

A/D conversion operations are performed continuously until bit 7 (ADCS) of the A/D converter mode register (ADM) is reset (0) by software.

- ★ If a write operation is performed to the analog input channel specification register (ADS) during an A/D conversion operation, the conversion operation is initialized, and if the ADCS bit is set (1), conversion starts again from the beginning.

Reset signal generation sets the A/D conversion result register (ADCR, ADCRH) to 0000H or 00H.

13.4.2 Input voltage and conversion results

The relationship between the analog input voltage input to the analog input pins (ANI0 to ANI7) and the theoretical A/D conversion result (stored in the 10-bit A/D conversion result register (ADCR)) is shown by the following expression.

$$SAR = \text{INT} \left(\frac{V_{AIN}}{AV_{REF}} \times 1024 + 0.5 \right)$$

$$ADCR = SAR \times 64$$

or

$$\left(\frac{ADCR}{64} - 0.5 \right) \times \frac{AV_{REF}}{1024} \leq V_{AIN} < \left(\frac{ADCR}{64} + 0.5 \right) \times \frac{AV_{REF}}{1024}$$

where, INT(): Function which returns integer part of value in parentheses

V_{AIN} : Analog input voltage

AV_{REF} : AV_{REF} pin voltage

ADCR: A/D conversion result register (ADCR) value

SAR: Successive approximation register

Figure 13-12 shows the relationship between the analog input voltage and the A/D conversion result.

Figure 13-12. Relationship Between Analog Input Voltage and A/D Conversion Result

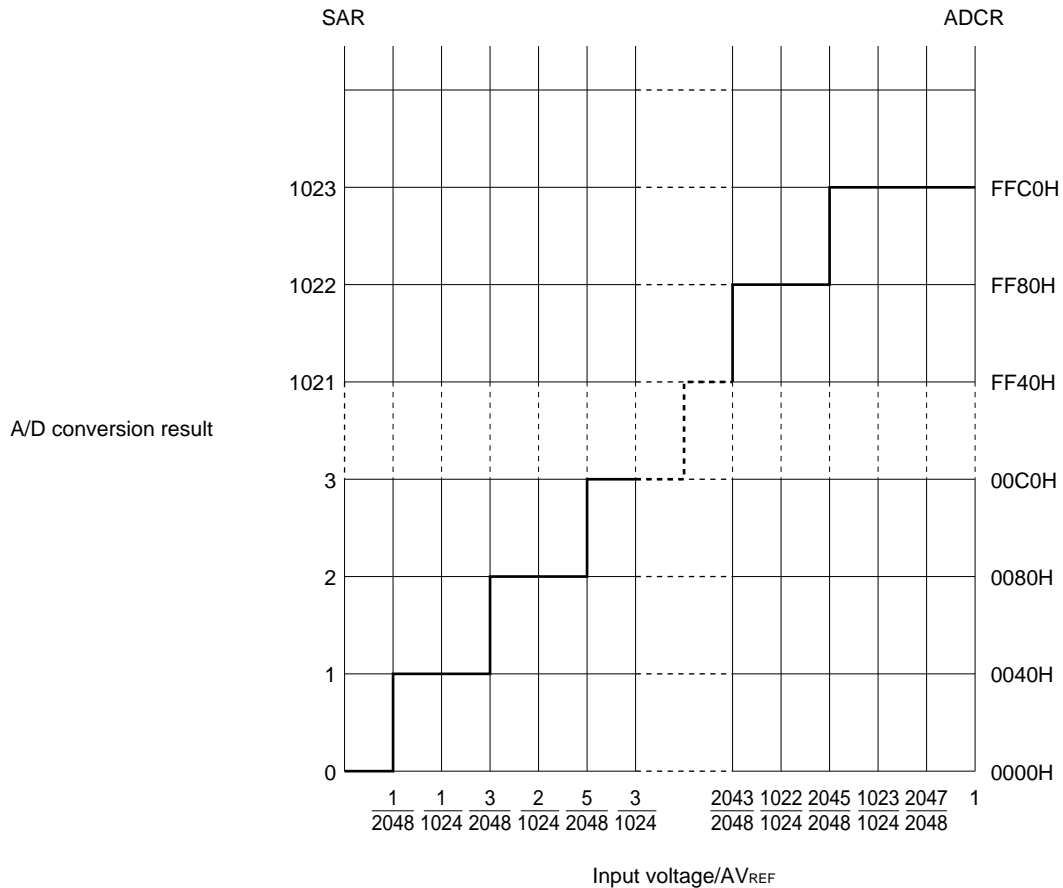

13.4.3 A/D converter operation mode

The operation mode of the A/D converter is the select mode. One channel of analog input is selected from ANI0 to ANI7 by the analog input channel specification register (ADS) and A/D conversion is executed.

(1) A/D conversion operation

By setting bit 7 (ADCS) of the A/D converter mode register (ADM) to 1, the A/D conversion operation of the voltage, which is applied to the analog input pin specified by the analog input channel specification register (ADS), is started.

When A/D conversion has been completed, the result of the A/D conversion is stored in the A/D conversion result register (ADCR), and an interrupt request signal (INTAD) is generated. When one A/D conversion has been completed, the next A/D conversion operation is immediately started.

- ★ If ADS is rewritten during A/D conversion, the A/D conversion operation under execution is stopped and restarted from the beginning.
- If 0 is written to ADCS during A/D conversion, A/D conversion is immediately stopped. At this time, the conversion result immediately before is retained.

Figure 13-13. A/D Conversion Operation

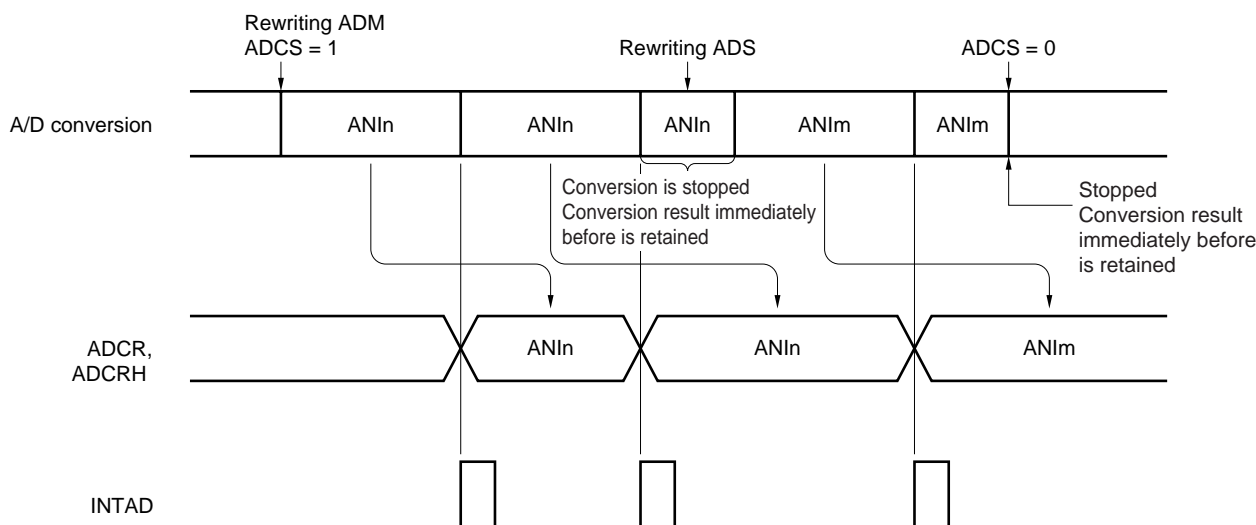

- Remarks**
1. n = 0 to 7
 2. m = 0 to 7

★ The setting methods are described below.

- <1> Set bit 0 (ADCE) of the A/D converter mode register (ADM) to 1.
- <2> Set the channel to be used in the analog input mode by using bits 3 to 0 (ADPC3 to ADPC0) of the A/D port configuration register (ADPC) and bits 7 to 0 (PM27 to PM20) of port mode register 2 (PM2).
- <3> Select conversion time by using bits 5 to 1 (FR2 to FR0, LV1, and LV0) of ADM.
- <4> Select a channel to be used by using bits 2 to 0 (ADS2 to ADS0) of the analog input channel specification register (ADS).
- <5> Set bit 7 (ADCS) of ADM to 1 to start A/D conversion.
- <6> When one A/D conversion has been completed, an interrupt request signal (INTAD) is generated.
- <7> Transfer the A/D conversion data to the A/D conversion result register (ADCR, ADCRH).

<Change the channel>

- <8> Change the channel using bits 2 to 0 (ADS2 to ADS0) of ADS to start A/D conversion.
- <9> When one A/D conversion has been completed, an interrupt request signal (INTAD) is generated.
- <10> Transfer the A/D conversion data to the A/D conversion result register (ADCR, ADCRH).

<Complete A/D conversion>

- <11> Clear ADCS to 0.
- <12> Clear ADCE to 0.

- Cautions**
1. Make sure the period of <1> to <5> is 1 μ s or more.
 2. <1> may be done between <2> and <4>.
 3. <1> can be omitted. However, ignore data of the first conversion after <5> in this case.
 4. The period from <6> to <9> differs from the conversion time set using bits 5 to 1 (FR2 to FR0, LV1, LV0) of ADM. The period from <8> to <9> is the conversion time set using FR2 to FR0, LV1, and LV0.

13.5 How to Read A/D Converter Characteristics Table

Here, special terms unique to the A/D converter are explained.

(1) Resolution

This is the minimum analog input voltage that can be identified. That is, the percentage of the analog input voltage per bit of digital output is called 1LSB (Least Significant Bit). The percentage of 1LSB with respect to the full scale is expressed by %FSR (Full Scale Range).

1LSB is as follows when the resolution is 10 bits.

$$\begin{aligned} 1\text{LSB} &= 1/2^{10} = 1/1024 \\ &= 0.098\%\text{FSR} \end{aligned}$$

Accuracy has no relation to resolution, but is determined by overall error.

(2) Overall error

This shows the maximum error value between the actual measured value and the theoretical value.

Zero-scale error, full-scale error, integral linearity error, and differential linearity errors that are combinations of these express the overall error.

Note that the quantization error is not included in the overall error in the characteristics table.

(3) Quantization error

When analog values are converted to digital values, a $\pm 1/2\text{LSB}$ error naturally occurs. In an A/D converter, an analog input voltage in a range of $\pm 1/2\text{LSB}$ is converted to the same digital code, so a quantization error cannot be avoided.

Note that the quantization error is not included in the overall error, zero-scale error, full-scale error, integral linearity error, and differential linearity error in the characteristics table.

Figure 13-14. Overall Error

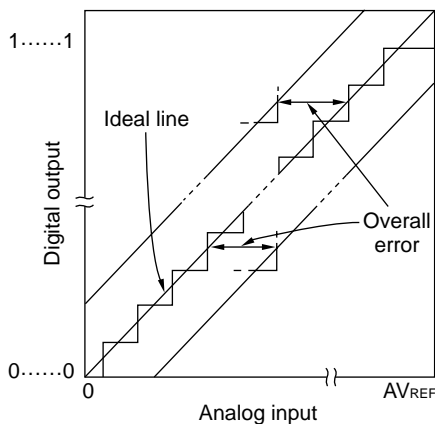
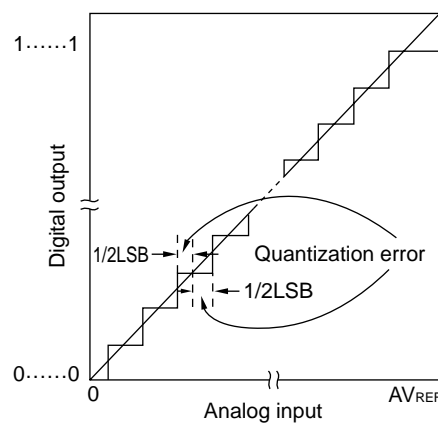

Figure 13-15. Quantization Error



(4) Zero-scale error

This shows the difference between the actual measurement value of the analog input voltage and the theoretical value ($1/2\text{LSB}$) when the digital output changes from $0.....000$ to $0.....001$.

If the actual measurement value is greater than the theoretical value, it shows the difference between the actual measurement value of the analog input voltage and the theoretical value ($3/2\text{LSB}$) when the digital output changes from $0.....001$ to $0.....010$.

(5) Full-scale error

This shows the difference between the actual measurement value of the analog input voltage and the theoretical value (Full-scale – 3/2LSB) when the digital output changes from 1.....110 to 1.....111.

(6) Integral linearity error

This shows the degree to which the conversion characteristics deviate from the ideal linear relationship. It expresses the maximum value of the difference between the actual measurement value and the ideal straight line when the zero-scale error and full-scale error are 0.

(7) Differential linearity error

While the ideal width of code output is 1LSB, this indicates the difference between the actual measurement value and the ideal value.

Figure 13-16. Zero-Scale Error

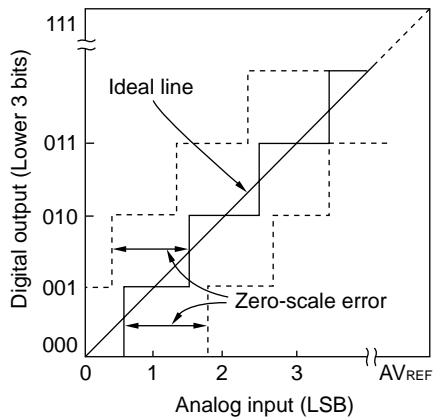

Figure 13-17. Full-Scale Error

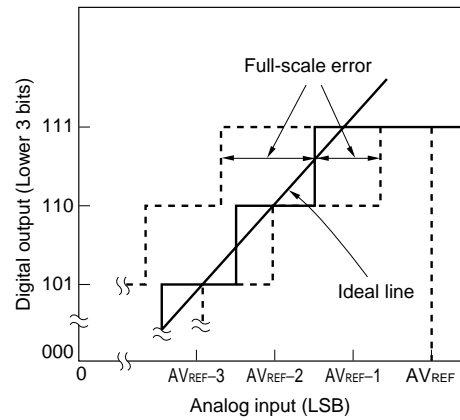

Figure 13-18. Integral Linearity Error

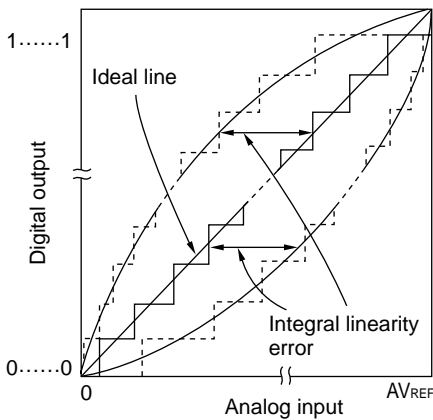
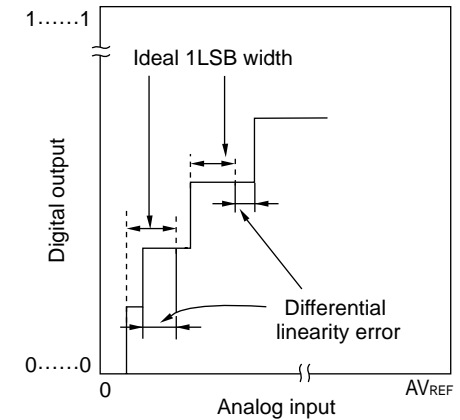

Figure 13-19. Differential Linearity Error



(8) Conversion time

This expresses the time from the start of sampling to when the digital output is obtained. The sampling time is included in the conversion time in the characteristics table.

(9) Sampling time

This is the time the analog switch is turned on for the analog voltage to be sampled by the sample & hold circuit.

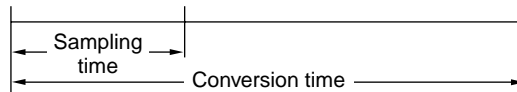

13.6 Cautions for A/D Converter

(1) Operating current in STOP mode

- ★ The A/D converter stops operating in the STOP mode. At this time, the operating current can be reduced by clearing bit 7 (ADCS) and bit 0 (ADCE) of the A/D converter mode register (ADM) to 0.
To restart from the standby status, clear bit 0 (ADIF) of interrupt request flag register 1L (IF1L) to 0 and start operation.

(2) Input range of ANI0 to ANI7

Observe the rated range of the ANI0 to ANI7 input voltage. If a voltage of AV_{REF} or higher and AV_{SS} or lower (even in the range of absolute maximum ratings) is input to an analog input channel, the converted value of that channel becomes undefined. In addition, the converted values of the other channels may also be affected.

(3) Conflicting operations

- <1> Conflict between A/D conversion result register (ADCR, ADCRH) write and ADCR or ADCRH read by instruction upon the end of conversion
ADCR or ADCRH read has priority. After the read operation, the new conversion result is written to ADCR or ADCRH.
- <2> Conflict between ADCR or ADCRH write and A/D converter mode register (ADM) write, analog input channel specification register (ADS), or A/D port configuration register (ADPC) write upon the end of conversion
ADM, ADS, or ADPC write has priority. ADCR or ADCRH write is not performed, nor is the conversion end interrupt signal (INTAD) generated.

★ (4) Noise countermeasures

To maintain the 10-bit resolution, attention must be paid to noise input to the AV_{REF} pin and pins ANI0 to ANI7.

- <1> Connect a capacitor with a low equivalent resistance and a good frequency response to the power supply.
- <2> The higher the output impedance of the analog input source, the greater the influence. To reduce the noise, connecting external C as shown in Figure 13-20 is recommended.
- <3> Do not switch these pins with other pins during conversion.
- <4> The accuracy is improved if the HALT mode is set immediately after the start of conversion.

Figure 13-20. Analog Input Pin Connection

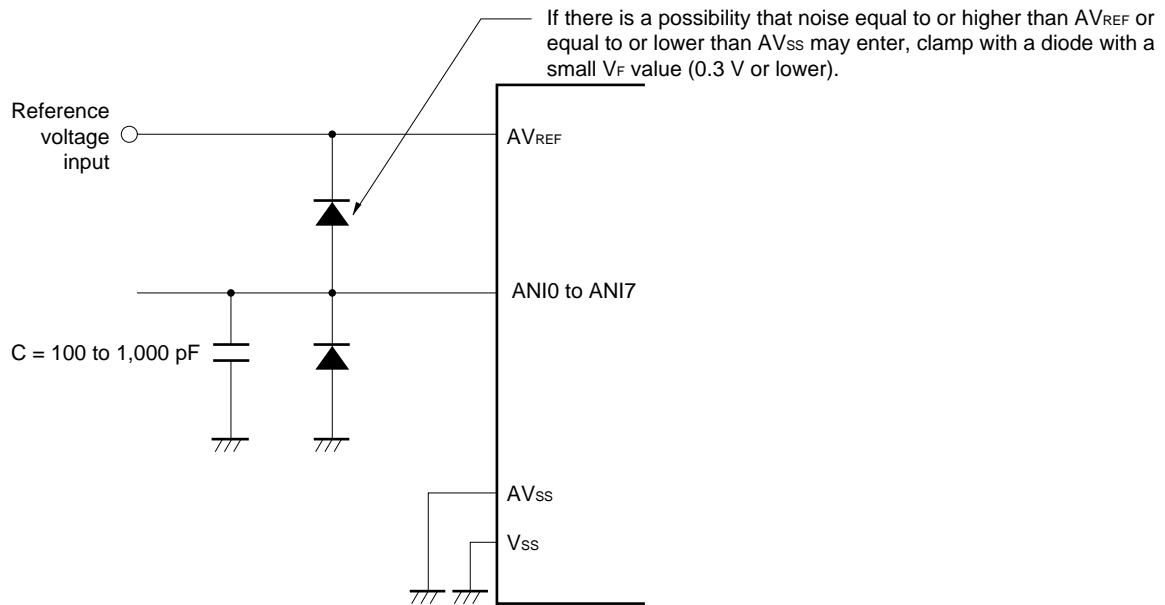
**(5) ANI0/P20 to ANI7/P27**

<1> The analog input pins (ANI0 to ANI7) are also used as input port pins (P20 to P27).

When A/D conversion is performed with any of ANI0 to ANI7 selected, do not access P20 to P27 while conversion is in progress; otherwise the conversion resolution may be degraded. It is recommended to select pins used as P20 to P27 starting with the ANI0/P20 that is the furthest from AVREF.

<2> If a digital pulse is applied to the pins adjacent to the pins currently used for A/D conversion, the expected value of the A/D conversion may not be obtained due to coupling noise. Therefore, do not apply a pulse to the pins adjacent to the pin undergoing A/D conversion.

(6) Input impedance of ANI0 to ANI7 pins

This A/D converter charges a sampling capacitor for sampling during sampling time.

Therefore, only a leakage current flows when sampling is not in progress, and a current that charges the capacitor flows during sampling. Consequently, the input impedance fluctuates depending on whether sampling is in progress, and on the other states.

To make sure that sampling is effective, however, it is recommended to keep the output impedance of the analog input source to within 10 k Ω , and to connect a capacitor of about 100 pF to the ANI0 to ANI7 pins (see **Figure 13-20**).

(7) AVREF pin input impedance

A series resistor string of several tens of k Ω is connected between the AVREF and AVSS pins.

Therefore, if the output impedance of the reference voltage source is high, this will result in a series connection to the series resistor string between the AVREF and AVSS pins, resulting in a large reference voltage error.

(8) Interrupt request flag (ADIF)

The interrupt request flag (ADIF) is not cleared even if the analog input channel specification register (ADS) is changed.

Therefore, if an analog input pin is changed during A/D conversion, the A/D conversion result and ADIF for the pre-change analog input may be set just before the ADS rewrite. Caution is therefore required since, at this time, when ADIF is read immediately after the ADS rewrite, ADIF is set despite the fact A/D conversion for the post-change analog input has not ended.

When A/D conversion is stopped and then resumed, clear ADIF before the A/D conversion operation is resumed.

Figure 13-21. Timing of A/D Conversion End Interrupt Request Generation

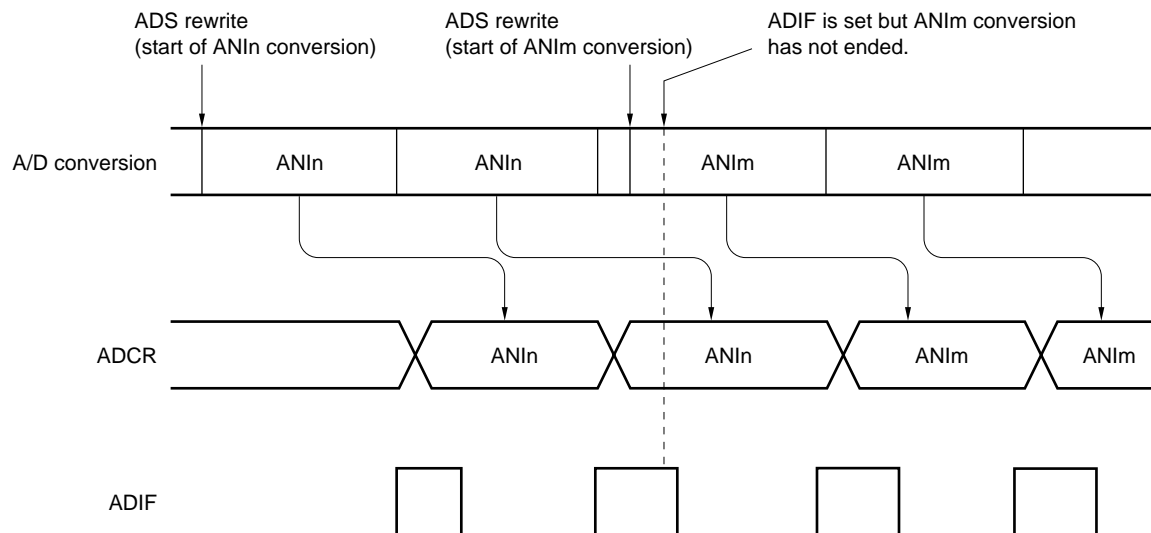

- Remarks 1. n = 0 to 7
- 2. m = 0 to 7

(9) Conversion results just after A/D conversion start

The first A/D conversion value immediately after A/D conversion starts may not fall within the rating range if the ADCS bit is set to 1 within 1 μ s after the ADCE bit was set to 1, or if the ADCS bit is set to 1 with the ADCE bit = 0. Take measures such as polling the A/D conversion end interrupt request (INTAD) and removing the first conversion result.

(10) A/D conversion result register (ADCR, ADCRH) read operation

When a write operation is performed to the A/D converter mode register (ADM), analog input channel specification register (ADS), and A/D port configuration register (ADPC), the contents of ADCR and ADCRH may become undefined. Read the conversion result following conversion completion before writing to ADM, ADS, and ADPC. Using a timing other than the above may cause an incorrect conversion result to be read.

★ (11) Internal equivalent circuit

The equivalent circuit of the analog input block is shown below.

Figure 13-22. Internal Equivalent Circuit of ANIn Pin

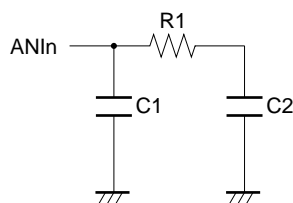

Table 13-4. Resistance and Capacitance Values of Equivalent Circuit (Reference Values)

AV_{REF}	R1	C1	C2
$4.0\text{ V} \leq AV_{REF} \leq 5.5\text{ V}$	8.1 k Ω	8 pF	5 pF
$2.7\text{ V} \leq AV_{REF} < 4.0\text{ V}$	31 k Ω	8 pF	5 pF
$2.3\text{ V} \leq AV_{REF} < 2.7\text{ V}$	381 k Ω	8 pF	5 pF

Remarks 1. The resistance and capacitance values shown in Table 13-4 are not guaranteed values.

2. n = 0 to 7

CHAPTER 14 SERIAL INTERFACE UART0

14.1 Functions of Serial Interface UART0

Serial interface UART0 has the following two modes.

(1) Operation stop mode

This mode is used when serial communication is not executed and can enable a reduction in the power consumption.

For details, see **14.4.1 Operation stop mode**.

(2) Asynchronous serial interface (UART) mode

The functions of this mode are outlined below.

For details, see **14.4.2 Asynchronous serial interface (UART) mode** and **14.4.3 Dedicated baud rate generator**.

- ★
 - Maximum transfer rate: 312.5 kbps
 - Two-pin configuration TxD0: Transmit data output pin
RxD0: Receive data input pin
 - Length of communication data can be selected from 7 or 8 bits.
 - Dedicated on-chip 5-bit baud rate generator allowing any baud rate to be set
 - Transmission and reception can be performed independently (full-duplex operation).
 - Fixed to LSB-first communication

Cautions 1. If clock supply to serial interface UART0 is not stopped (e.g., in the HALT mode), normal operation continues. If clock supply to serial interface UART0 is stopped (e.g., in the STOP mode), each register stops operating, and holds the value immediately before clock supply was stopped. The TxD0 pin also holds the value immediately before clock supply was stopped and outputs it. However, the operation is not guaranteed after clock supply is resumed. Therefore, reset the circuit so that POWER0 = 0, RXE0 = 0, and TXE0 = 0.

2. Set POWER0 = 1 and then set TXE0 = 1 (transmission) or RXE0 = 1 (reception) to start communication.

3. TXE0 and RXE0 are synchronized by the base clock (f_{XCLK0}) set by BRGC0. To enable transmission or reception again, set TXE0 or RXE0 to 1 at least two clocks of base clock after TXE0 or RXE0 has been cleared to 0. If TXE0 or RXE0 is set within two clocks of base clock, the transmission circuit or reception circuit may not be initialized.

- ★
 - 4. Set transmit data to TXS0 at least one base clock (f_{XCLK0}) after setting TXE0 = 1.

14.2 Configuration of Serial Interface UART0

Serial interface UART0 includes the following hardware.

Table 14-1. Configuration of Serial Interface UART0

Item	Configuration
Registers	Receive buffer register 0 (RXB0) Receive shift register 0 (RXS0) Transmit shift register 0 (TXS0)
Control registers	Asynchronous serial interface operation mode register 0 (ASIM0) Asynchronous serial interface reception error status register 0 (ASIS0) Baud rate generator control register 0 (BRGC0) Port mode register 1 (PM1) Port register 1 (P1)

Figure 14-1. Block Diagram of Serial Interface UART0

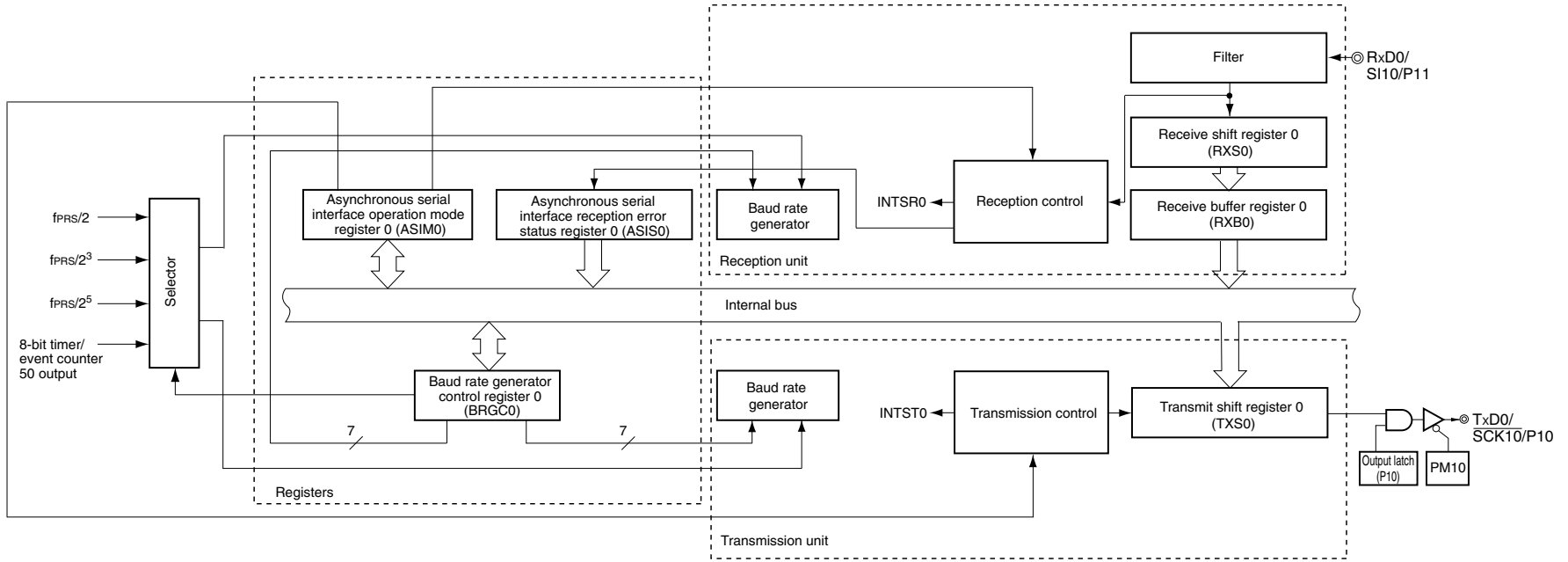

(1) Receive buffer register 0 (RXB0)

This 8-bit register stores parallel data converted by receive shift register 0 (RXS0).

Each time 1 byte of data has been received, new receive data is transferred to this register from receive shift register 0 (RXS0).

If the data length is set to 7 bits the receive data is transferred to bits 0 to 6 of RXB0 and the MSB of RXB0 is always 0.

If an overrun error (OVE0) occurs, the receive data is not transferred to RXB0.

RXB0 can be read by an 8-bit memory manipulation instruction. No data can be written to this register.

Reset signal generation and POWER0 = 0 set this register to FFH.

(2) Receive shift register 0 (RXS0)

This register converts the serial data input to the RxD0 pin into parallel data.

RXS0 cannot be directly manipulated by a program.

(3) Transmit shift register 0 (TXS0)

This register is used to set transmit data. Transmission is started when data is written to TXS0, and serial data is transmitted from the TxD0 pins.

TXS0 can be written by an 8-bit memory manipulation instruction. This register cannot be read.

Reset signal generation, POWER0 = 0, and TXE0 = 0 set this register to FFH.

- ★ **Cautions**
- 1. Set transmit data to TXS0 at least one base clock (f_{CLK0}) after setting TXE0 = 1.**
 - 2. Do not write the next transmit data to TXS0 before the transmission completion interrupt signal (INTST0) is generated.**

14.3 Registers Controlling Serial Interface UART0

Serial interface UART0 is controlled by the following five registers.

- Asynchronous serial interface operation mode register 0 (ASIM0)
- Asynchronous serial interface reception error status register 0 (ASIS0)
- Baud rate generator control register 0 (BRGC0)
- Port mode register 1 (PM1)
- Port register 1 (P1)

(1) Asynchronous serial interface operation mode register 0 (ASIM0)

This 8-bit register controls the serial communication operations of serial interface UART0.

This register can be set by a 1-bit or 8-bit memory manipulation instruction.

Reset signal generation sets this register to 01H.

Figure 14-2. Format of Asynchronous Serial Interface Operation Mode Register 0 (ASIM0) (1/2)

Address: FF70H After reset: 01H R/W

Symbol	<7>	<6>	<5>	4	3	2	1	0
ASIM0	POWER0	TXE0	RXE0	PS01	PS00	CL0	SL0	1

POWER0	Enables/disables operation of internal operation clock
0 ^{Note 1}	Disables operation of the internal operation clock (fixes the clock to low level) and asynchronously resets the internal circuit ^{Note 2} .
1	Enables operation of the internal operation clock.

TXE0	Enables/disables transmission
0	Disables transmission (synchronously resets the transmission circuit).
1	Enables transmission.

RXE0	Enables/disables reception
0	Disables reception (synchronously resets the reception circuit).
1	Enables reception.

- Notes**
1. The input from the RxD0 pin is fixed to high level when POWER0 = 0.
 2. Asynchronous serial interface reception error status register 0 (ASIS0), transmit shift register 0 (TXS0), and receive buffer register 0 (RXB0) are reset.

Figure 14-2. Format of Asynchronous Serial Interface Operation Mode Register 0 (ASIM0) (2/2)

PS01	PS00	Transmission operation	Reception operation
0	0	Does not output parity bit.	Reception without parity
0	1	Outputs 0 parity.	Reception as 0 parity ^{Note}
1	0	Outputs odd parity.	Judges as odd parity.
1	1	Outputs even parity.	Judges as even parity.

CL0	Specifies character length of transmit/receive data
0	Character length of data = 7 bits
1	Character length of data = 8 bits

SL0	Specifies number of stop bits of transmit data
0	Number of stop bits = 1
1	Number of stop bits = 2

Note If “reception as 0 parity” is selected, the parity is not judged. Therefore, bit 2 (PE0) of asynchronous serial interface reception error status register 0 (ASIS0) is not set and the error interrupt does not occur.

- Cautions**
1. To start the transmission, set POWER0 to 1 and then set TXE0 to 1. To stop the transmission, clear TXE0 to 0, and then clear POWER0 to 0.
 2. To start the reception, set POWER0 to 1 and then set RXE0 to 1. To stop the reception, clear RXE0 to 0, and then clear POWER0 to 0.
 3. Set POWER0 to 1 and then set RXE0 to 1 while a high level is input to the RxD0 pin. If POWER0 is set to 1 and RXE0 is set to 1 while a low level is input, reception is started.
 4. TXE0 and RXE0 are synchronized by the base clock (f_{XCLK0}) set by BRGC0. To enable transmission or reception again, set TXE0 or RXE0 to 1 at least two clocks of base clock after TXE0 or RXE0 has been cleared to 0. If TXE0 or RXE0 is set within two clocks of base clock, the transmission circuit or reception circuit may not be initialized.
 5. Set transmit data to TXS0 at least one base clock (f_{XCLK0}) after setting TXE0 = 1.
 6. Clear the TXE0 and RXE0 bits to 0 before rewriting the PS01, PS00, and CL0 bits.
 7. Make sure that TXE0 = 0 when rewriting the SL0 bit. Reception is always performed with “number of stop bits = 1”, and therefore, is not affected by the set value of the SL0 bit.
 8. Be sure to set bit 0 to 1.

★

(2) Asynchronous serial interface reception error status register 0 (ASIS0)

This register indicates an error status on completion of reception by serial interface UART0. It includes three error flag bits (PE0, FE0, OVE0).

This register is read-only by an 8-bit memory manipulation instruction.

Reset signal generation sets this register to 00H if bit 7 (POWER0) and bit 5 (RXE0) of ASIM0 = 0. 00H is read when this register is read. If a reception error occurs, read ASIS0 and then read receive buffer register 0 (RXB0) to clear the error flag.

Figure 14-3. Format of Asynchronous Serial Interface Reception Error Status Register 0 (ASIS0)

Address: FF73H After reset: 00H R

Symbol	7	6	5	4	3	2	1	0
ASIS0	0	0	0	0	0	PE0	FE0	OVE0

PE0	Status flag indicating parity error
0	If POWER0 = 0 and RXE0 = 0, or if ASIS0 register is read.
1	If the parity of transmit data does not match the parity bit on completion of reception.

FE0	Status flag indicating framing error
0	If POWER0 = 0 and RXE0 = 0, or if ASIS0 register is read.
1	If the stop bit is not detected on completion of reception.

OVE0	Status flag indicating overrun error
0	If POWER0 = 0 and RXE0 = 0, or if ASIS0 register is read.
1	If receive data is set to the RXB0 register and the next reception operation is completed before the data is read.

- Cautions**
1. The operation of the PE0 bit differs depending on the set values of the PS01 and PS00 bits of asynchronous serial interface operation mode register 0 (ASIM0).
 2. Only the first bit of the receive data is checked as the stop bit, regardless of the number of stop bits.
 3. If an overrun error occurs, the next receive data is not written to receive buffer register 0 (RXB0) but discarded.
 4. If data is read from ASIS0, a wait cycle is generated. Do not read data from ASIS0 when the CPU is operating on the subsystem clock and the peripheral hardware clock is stopped. For details, see CHAPTER 31 CAUTIONS FOR WAIT.

(3) Baud rate generator control register 0 (BRGC0)

This register selects the base clock of serial interface UART0 and the division value of the 5-bit counter. BRGC0 can be set by an 8-bit memory manipulation instruction. Reset signal generation sets this register to 1FH.

Figure 14-4. Format of Baud Rate Generator Control Register 0 (BRGC0)

Address: FF71H After reset: 1FH R/W

Symbol	7	6	5	4	3	2	1	0
BRGC0	TPS01	TPS00	0	MDL04	MDL03	MDL02	MDL01	MDL00

TPS01	TPS00	Base clock (f _{CLK0}) selection				
		f _{PRS} = 2 MHz	f _{PRS} = 5 MHz	f _{PRS} = 10 MHz	f _{PRS} = 20 MHz	
0	0	TM50 output ^{Note}				
0	1	f _{PRS} /2	1 MHz	2.5 MHz	5 MHz	10 MHz
1	0	f _{PRS} /2 ³	250 kHz	625 kHz	1.25 MHz	2.5 MHz
1	1	f _{PRS} /2 ⁵	62.5 kHz	156.25 kHz	312.5 kHz	625 kHz

MDL04	MDL03	MDL02	MDL01	MDL00	k	Selection of 5-bit counter output clock
0	0	×	×	×	×	Setting prohibited
0	1	0	0	0	8	f _{CLK0} /8
0	1	0	0	1	9	f _{CLK0} /9
0	1	0	1	0	10	f _{CLK0} /10
•	•	•	•	•	•	•
•	•	•	•	•	•	•
•	•	•	•	•	•	•
•	•	•	•	•	•	•
•	•	•	•	•	•	•
1	1	0	1	0	26	f _{CLK0} /26
1	1	0	1	1	27	f _{CLK0} /27
1	1	1	0	0	28	f _{CLK0} /28
1	1	1	0	1	29	f _{CLK0} /29
1	1	1	1	0	30	f _{CLK0} /30
1	1	1	1	1	31	f _{CLK0} /31

- Note** Note the following points when selecting the TM50 output as the base clock.
- Mode in which the count clock is cleared and started upon a match of TM50 and CR50 (TMC506 = 0)
Start the operation of 8-bit timer/event counter 50 first and then enable the timer F/F inversion operation (TMC501 = 1).
 - PWM mode (TMC506 = 1)
Start the operation of 8-bit timer/event counter 50 first and then set the count clock to make the duty = 50%.
- It is not necessary to enable the TO50 pin as a timer output pin in any mode.

- Cautions**
1. Make sure that bit 6 (TXE0) and bit 5 (RXE0) of the ASIM0 register = 0 when rewriting the MDL04 to MDL00 bits.
 2. The baud rate value is the output clock of the 5-bit counter divided by 2.

- Remarks**
1. f_{CLK0} : Frequency of base clock selected by the TPS01 and TPS00 bits
 2. f_{PRS} : Peripheral hardware clock frequency
 3. k : Value set by the MDL04 to MDL00 bits ($k = 8, 9, 10, \dots, 31$)
 4. \times : Don't care
 5. TMC506: Bit 6 of 8-bit timer mode control register 50 (TMC50)
TMC501: Bit 1 of TMC50

(4) Port mode register 1 (PM1)

This register sets port 1 input/output in 1-bit units.

When using the P10/TxD0/ $\overline{SCK10}$ pin for serial interface data output, clear PM10 to 0 and set the output latch of P10 to 1.

When using the P11/RxD0/SI10 pin for serial interface data input, set PM11 to 1. The output latch of P11 at this time may be 0 or 1.

PM1 can be set by a 1-bit or 8-bit memory manipulation instruction.

Reset signal generation sets this register to FFH.

Figure 14-5. Format of Port Mode Register 1 (PM1)

Address: FF21H After reset: FFH R/W

Symbol	7	6	5	4	3	2	1	0
PM1	PM17	PM16	PM15	PM14	PM13	PM12	PM11	PM10

PM1n	P1n pin I/O mode selection (n = 0 to 7)
0	Output mode (output buffer on)
1	Input mode (output buffer off)

14.4 Operation of Serial Interface UART0

Serial interface UART0 has the following two modes.

- Operation stop mode
- Asynchronous serial interface (UART) mode

14.4.1 Operation stop mode

In this mode, serial communication cannot be executed, thus reducing the power consumption. In addition, the pins can be used as ordinary port pins in this mode. To set the operation stop mode, clear bits 7, 6, and 5 (POWER0, TXE0, and RXE0) of ASIM0 to 0.

(1) Register used

The operation stop mode is set by asynchronous serial interface operation mode register 0 (ASIM0).

ASIM0 can be set by a 1-bit or 8-bit memory manipulation instruction.

Reset signal generation sets this register to 01H.

Address: FF70H After reset: 01H R/W

Symbol	<7>	<6>	<5>	4	3	2	1	0
ASIM0	POWER0	TXE0	RXE0	PS01	PS00	CL0	SL0	1

POWER0	Enables/disables operation of internal operation clock
0 ^{Note 1}	Disables operation of the internal operation clock (fixes the clock to low level) and asynchronously resets the internal circuit ^{Note 2} .

TXE0	Enables/disables transmission
0	Disables transmission (synchronously resets the transmission circuit).

RXE0	Enables/disables reception
0	Disables reception (synchronously resets the reception circuit).

- Notes**
1. The input from the RxD0 pin is fixed to high level when POWER0 = 0.
 2. Asynchronous serial interface reception error status register 0 (ASIS0), transmit shift register 0 (TXS0), and receive buffer register 0 (RXB0) are reset.

Caution Clear POWER0 to 0 after clearing TXE0 and RXE0 to 0 to set the operation stop mode. To start the communication, set POWER0 to 1, and then set TXE0 or RXE0 to 1.

Remark To use the RxD0/SI10/P11 and TxD0/SCK10/P10 pins as general-purpose port pins, see **CHAPTER 5 PORT FUNCTIONS**.

14.4.2 Asynchronous serial interface (UART) mode

In this mode, 1-byte data is transmitted/received following a start bit, and a full-duplex operation can be performed.

A dedicated UART baud rate generator is incorporated, so that communication can be executed at a wide range of baud rates.

(1) Registers used

- Asynchronous serial interface operation mode register 0 (ASIM0)
- Asynchronous serial interface reception error status register 0 (ASIS0)
- Baud rate generator control register 0 (BRGC0)
- Port mode register 1 (PM1)
- Port register 1 (P1)

The basic procedure of setting an operation in the UART mode is as follows.

- <1> Set the BRGC0 register (see **Figure 14-4**).
- <2> Set bits 1 to 4 (SL0, CL0, PS00, and PS01) of the ASIM0 register (see **Figure 14-2**).
- <3> Set bit 7 (POWER0) of the ASIM0 register to 1.
- <4> Set bit 6 (TXE0) of the ASIM0 register to 1. → Transmission is enabled.
Set bit 5 (RXE0) of the ASIM0 register to 1. → Reception is enabled.
- <5> Write data to the TXS0 register. → Data transmission is started.

Caution Take relationship with the other party of communication when setting the port mode register and port register.

The relationship between the register settings and pins is shown below.

Table 14-2. Relationship Between Register Settings and Pins

POWER0	TXE0	RXE0	PM10	P10	PM11	P11	UART0 Operation	Pin Function	
								TxD0/SCK10/P10	RxD0/SI10/P11
0	0	0	× ^{Note}	× ^{Note}	× ^{Note}	×			

(2) Communication operation

(a) Format and waveform example of normal transmit/receive data

Figures 14-6 and 14-7 show the format and waveform example of the normal transmit/receive data.

Figure 14-6. Format of Normal UART Transmit/Receive Data

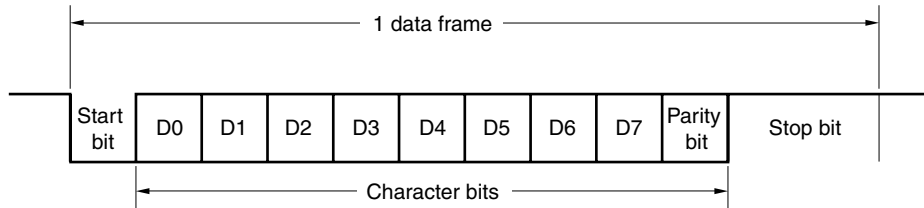

One data frame consists of the following bits.

- Start bit ... 1 bit
- Character bits ... 7 or 8 bits (LSB first)
- Parity bit ... Even parity, odd parity, 0 parity, or no parity
- Stop bit ... 1 or 2 bits

The character bit length, parity, and stop bit length in one data frame are specified by asynchronous serial interface operation mode register 0 (ASIM0).

Figure 14-7. Example of Normal UART Transmit/Receive Data Waveform

1. Data length: 8 bits, Parity: Even parity, Stop bit: 1 bit, Communication data: 55H

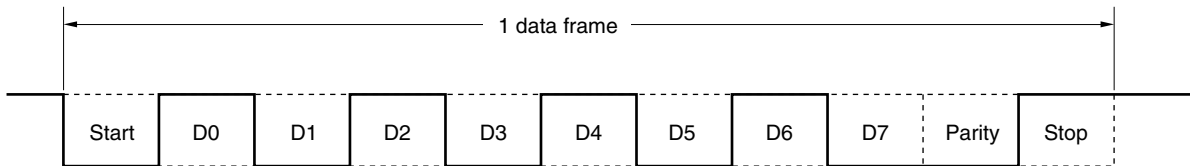

2. Data length: 7 bits, Parity: Odd parity, Stop bit: 2 bits, Communication data: 36H

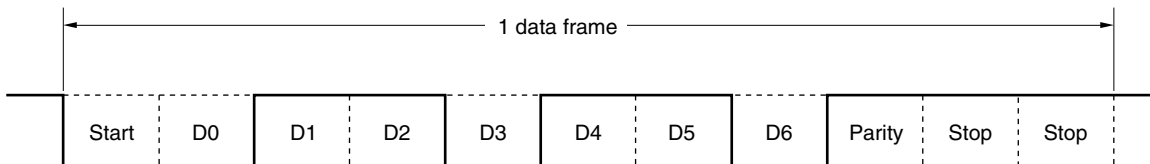

3. Data length: 8 bits, Parity: None, Stop bit: 1 bit, Communication data: 87H

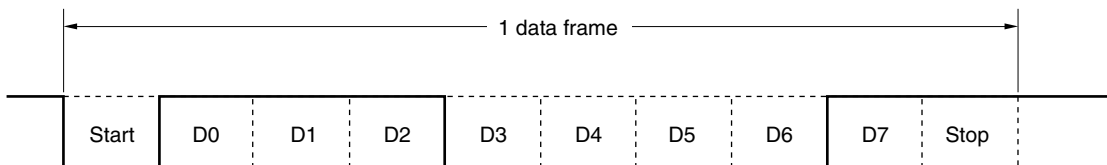

(b) Parity types and operation

The parity bit is used to detect a bit error in communication data. Usually, the same type of parity bit is used on both the transmission and reception sides. With even parity and odd parity, a 1-bit (odd number) error can be detected. With zero parity and no parity, an error cannot be detected.

(i) Even parity

- Transmission

Transmit data, including the parity bit, is controlled so that the number of bits that are “1” is even.

The value of the parity bit is as follows.

If transmit data has an odd number of bits that are “1”: 1

If transmit data has an even number of bits that are “1”: 0

- Reception

The number of bits that are “1” in the receive data, including the parity bit, is counted. If it is odd, a parity error occurs.

(ii) Odd parity

- Transmission

Unlike even parity, transmit data, including the parity bit, is controlled so that the number of bits that are “1” is odd.

If transmit data has an odd number of bits that are “1”: 0

If transmit data has an even number of bits that are “1”: 1

- Reception

The number of bits that are “1” in the receive data, including the parity bit, is counted. If it is even, a parity error occurs.

(iii) 0 parity

The parity bit is cleared to 0 when data is transmitted, regardless of the transmit data.

The parity bit is not detected when the data is received. Therefore, a parity error does not occur regardless of whether the parity bit is “0” or “1”.

(iv) No parity

No parity bit is appended to the transmit data.

Reception is performed assuming that there is no parity bit when data is received. Because there is no parity bit, a parity error does not occur.

(c) Transmission

If bit 7 (POWER0) of asynchronous serial interface operation mode register 0 (ASIM0) is set to 1 and bit 6 (TXE0) of ASIM0 is then set to 1, transmission is enabled. Transmission can be started by writing transmit data to transmit shift register 0 (TXS0). The start bit, parity bit, and stop bit are automatically appended to the data.

When transmission is started, the start bit is output from the TxD0 pin, and the transmit data is output followed by the rest of the data in order starting from the LSB. When transmission is completed, the parity and stop bits set by ASIM0 are appended and a transmission completion interrupt request (INTST0) is generated.

Transmission is stopped until the data to be transmitted next is written to TXS0.

Figure 14-8 shows the timing of the transmission completion interrupt request (INTST0). This interrupt occurs as soon as the last stop bit has been output.

Caution After transmit data is written to TXS0, do not write the next transmit data before the transmission completion interrupt signal (INTST0) is generated.

Figure 14-8. Transmission Completion Interrupt Request Timing

1. Stop bit length: 1

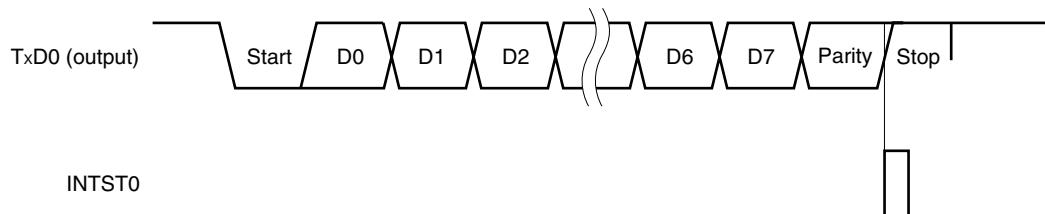

2. Stop bit length: 2

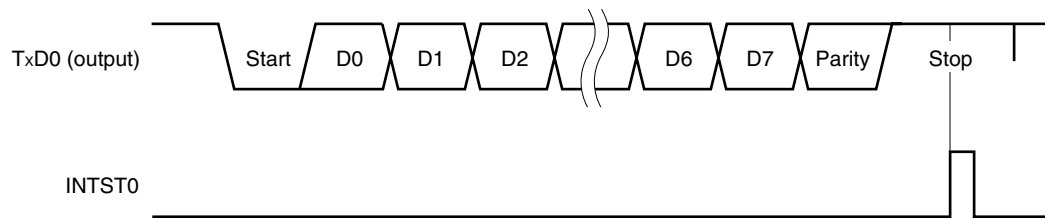

(d) Reception

Reception is enabled and the RxD0 pin input is sampled when bit 7 (POWER0) of asynchronous serial interface operation mode register 0 (ASIM0) is set to 1 and then bit 5 (RXE0) of ASIM0 is set to 1.

The 5-bit counter of the baud rate generator starts counting when the falling edge of the RxD0 pin input is detected. When the set value of baud rate generator control register 0 (BRGC0) has been counted, the RxD0 pin input is sampled again (∇ in Figure 14-9). If the RxD0 pin is low level at this time, it is recognized as a start bit.

When the start bit is detected, reception is started, and serial data is sequentially stored in receive shift register 0 (RXS0) at the set baud rate. When the stop bit has been received, the reception completion interrupt (INTSR0) is generated and the data of RXS0 is written to receive buffer register 0 (RXB0). If an overrun error (OVE0) occurs, however, the receive data is not written to RXB0.

Even if a parity error (PE0) occurs while reception is in progress, reception continues to the reception position of the stop bit, and an reception error interrupt (INTSR0) is generated after completion of reception. INTSR0 occurs upon completion of reception and in case of a reception error.

Figure 14-9. Reception Completion Interrupt Request Timing

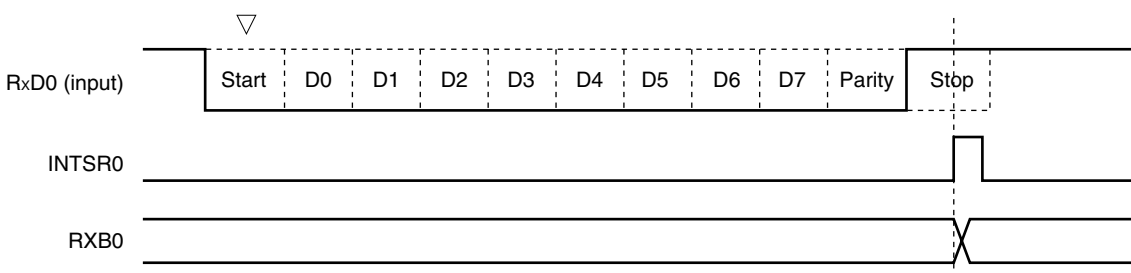

- ★ **Cautions**
1. If a reception error occurs, read asynchronous serial interface reception error status register 0 (ASIS0) and then read receive buffer register 0 (RXB0) to clear the error flag. Otherwise, an overrun error will occur when the next data is received, and the reception error status will persist.
 2. Reception is always performed with the “number of stop bits = 1”. The second stop bit is ignored.

(e) Reception error

Three types of errors may occur during reception: a parity error, framing error, or overrun error. If the error flag of asynchronous serial interface reception error status register 0 (ASIS0) is set as a result of data reception, a reception error interrupt (INTSR0) is generated.

Which error has occurred during reception can be identified by reading the contents of ASIS0 in the reception error interrupt (INTSR0) servicing (see **Figure 14-3**).

The contents of ASIS0 are cleared to 0 when ASIS0 is read.

Table 14-3. Cause of Reception Error

Reception Error	Cause
Parity error	The parity specified for transmission does not match the parity of the receive data.
Framing error	Stop bit is not detected.
Overrun error	Reception of the next data is completed before data is read from receive buffer register 0 (RXB0).

(f) Noise filter of receive data

The RxD0 signal is sampled using the base clock output by the prescaler block.

If two sampled values are the same, the output of the match detector changes, and the data is sampled as input data.

Because the circuit is configured as shown in Figure 14-10, the internal processing of the reception operation is delayed by two clocks from the external signal status.

Figure 14-10. Noise Filter Circuit

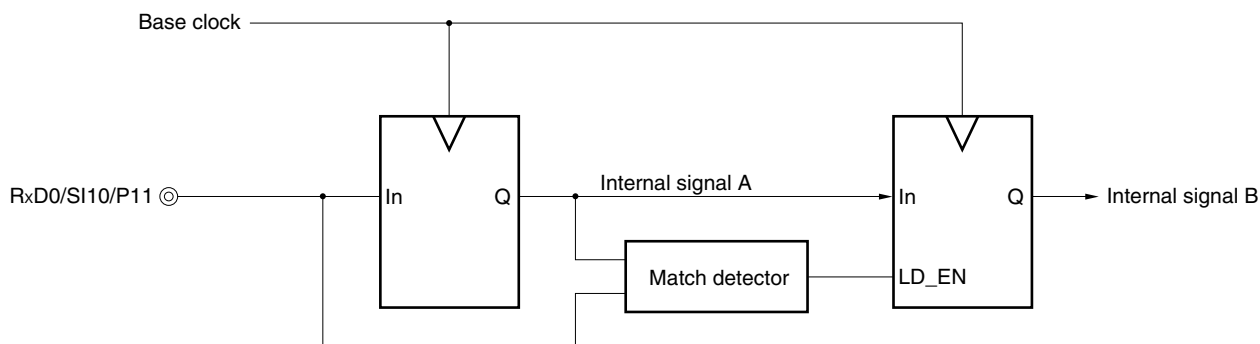

14.4.3 Dedicated baud rate generator

The dedicated baud rate generator consists of a source clock selector and a 5-bit programmable counter, and generates a serial clock for transmission/reception of UART0.

Separate 5-bit counters are provided for transmission and reception.

(1) Configuration of baud rate generator

- Base clock

The clock selected by bits 7 and 6 (TPS01 and TPS00) of baud rate generator control register 0 (BRGC0) is supplied to each module when bit 7 (POWER0) of asynchronous serial interface operation mode register 0 (ASIM0) is 1. This clock is called the base clock and its frequency is called f_{CLK0} . The base clock is fixed to low level when $POWER0 = 0$.

- Transmission counter

This counter stops operation, cleared to 0, when bit 7 (POWER0) or bit 6 (TXE0) of asynchronous serial interface operation mode register 0 (ASIM0) is 0.

It starts counting when $POWER0 = 1$ and $TXE0 = 1$.

The counter is cleared to 0 when the first data transmitted is written to transmit shift register 0 (TXS0).

- Reception counter

This counter stops operation, cleared to 0, when bit 7 (POWER0) or bit 5 (RXE0) of asynchronous serial interface operation mode register 0 (ASIM0) is 0.

It starts counting when the start bit has been detected.

The counter stops operation after one frame has been received, until the next start bit is detected.

Figure 14-11. Configuration of Baud Rate Generator

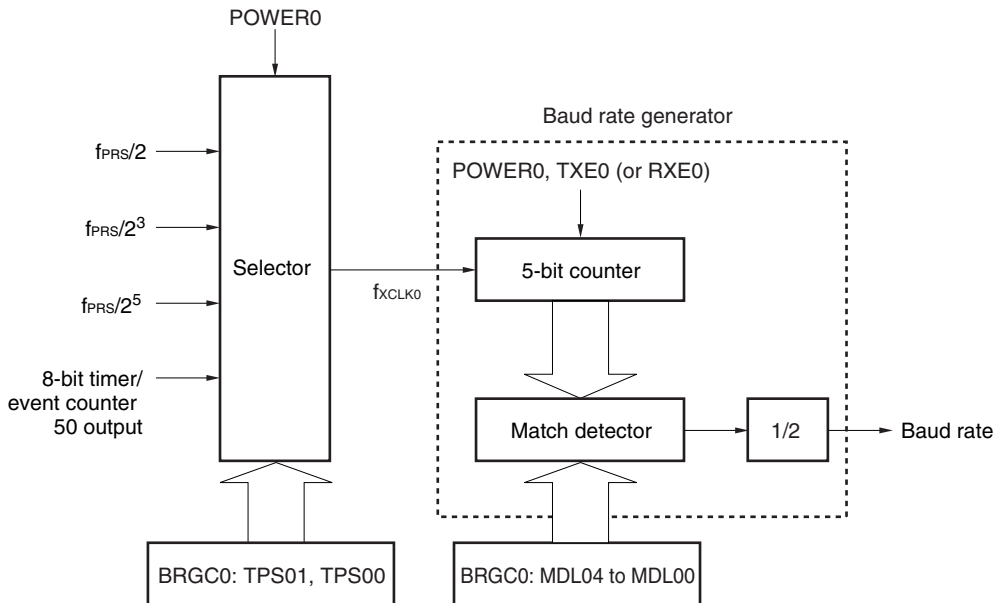

Remark POWER0: Bit 7 of asynchronous serial interface operation mode register 0 (ASIM0)
 TXE0: Bit 6 of ASIM0
 RXE0: Bit 5 of ASIM0
 BRGC0: Baud rate generator control register 0

(2) Generation of serial clock

A serial clock to be generated can be specified by using baud rate generator control register 0 (BRGC0). Select the clock to be input to the 5-bit counter by using bits 7 and 6 (TPS01 and TPS00) of BRGC0. Bits 4 to 0 (MDL04 to MDL00) of BRGC0 can be used to select the division value ($f_{XCLK0}/8$ to $f_{XCLK0}/31$) of the 5-bit counter.

★

Table 14-4. Set Value of TPS01 and TPS00

TPS01	TPS00	Base clock (f_{XCLK0}) selection				
		$f_{PRS} = 2 \text{ MHz}$	$f_{PRS} = 5 \text{ MHz}$	$f_{PRS} = 10 \text{ MHz}$	$f_{PRS} = 20 \text{ MHz}$	
0	0	TM50 output				
0	1	$f_{PRS}/2$	1 MHz	2.5 MHz	5 MHz	10 MHz
1	0	$f_{PRS}/2^3$	250 kHz	625 kHz	1.25 MHz	2.5 MHz
1	1	$f_{PRS}/2^5$	62.5 kHz	156.25 kHz	312.5 kHz	625 kHz

(a) Baud rate

The baud rate can be calculated by the following expression.

- Baud rate = $\frac{f_{XCLK0}}{2 \times k}$ [bps]

f_{XCLK0} : Frequency of base clock selected by the TPS01 and TPS00 bits of the BRGC0 register

k: Value set by the MDL04 to MDL00 bits of the BRGC0 register (k = 8, 9, 10, ..., 31)

(b) Error of baud rate

The baud rate error can be calculated by the following expression.

- Error (%) = $\left(\frac{\text{Actual baud rate (baud rate with error)}}{\text{Desired baud rate (correct baud rate)}} - 1 \right) \times 100$ [%]

Cautions 1. Keep the baud rate error during transmission to within the permissible error range at the reception destination.

2. Make sure that the baud rate error during reception satisfies the range shown in (4) Permissible baud rate range during reception.

Example: Frequency of base clock = 2.5 MHz = 2,500,000 Hz
 Set value of MDL04 to MDL00 bits of BRGC0 register = 10000B (k = 16)
 Target baud rate = 76,800 bps

$$\begin{aligned} \text{Baud rate} &= 2.5 \text{ M}/(2 \times 16) \\ &= 2,500,000/(2 \times 16) = 78,125 \text{ [bps]} \end{aligned}$$

$$\begin{aligned} \text{Error} &= (78,125/76,800 - 1) \times 100 \\ &= 1.725 \text{ [%]} \end{aligned}$$

(3) Example of setting baud rate

Table 14-5. Set Data of Baud Rate Generator

Baud Rate [bps]	$f_{PRS} = 2.0 \text{ MHz}$				$f_{PRS} = 5.0 \text{ MHz}$				$f_{PRS} = 10.0 \text{ MHz}$				$f_{PRS} = 20.0 \text{ MHz}$			
	TPS01, TPS00	k	Calculated Value	ERR [%]	TPS01, TPS00	k	Calculated Value	ERR [%]	TPS01, TPS00	k	Calculated Value	ERR [%]	TPS01, TPS00	k	Calculated Value	ERR [%]
4800	2	26	4808	0.16	3	16	4883	1.73	–	–	–	–	–	–	–	–
9600	2	13	9615	0.16	3	8	9766	1.73	3	16	9766	1.73	–	–	–	–
10400	2	12	10417	0.16	2	30	10417	0.16	3	15	10417	0.16	3	30	10417	0.16
19200	1	26	19231	0.16	2	16	19531	1.73	3	8	19531	1.73	3	16	19531	1.73
24000	1	21	23810	–0.79	2	13	24038	0.16	2	26	24038	0.16	3	13	24038	0.16
31250	1	16	31250	0	2	10	31250	0	2	20	31250	0	3	10	31250	0
33660	1	15	33333	–0.79	2	9	34722	3.34	2	18	34722	3.34	3	9	34722	3.34
38400	1	13	38462	0.16	2	8	39063	1.73	2	16	39063	1.73	3	8	39063	1.73
56000	1	9	55556	–0.79	1	22	56818	1.46	2	11	56818	1.46	2	22	56818	1.46
62500	1	8	62500	0	1	20	62500	0	2	10	62500	0	2	20	62500	0
76800	–	–	–	–	1	16	78125	1.73	2	8	78125	1.73	2	16	78125	1.73
115200	–	–	–	–	1	11	113636	–1.36	1	22	113636	–1.36	2	11	113636	–1.36
153600	–	–	–	–	1	8	156250	1.73	1	16	156250	1.73	2	8	156250	1.73

Remark TPS01, TPS00: Bits 7 and 6 of baud rate generator control register 0 (BRGC0) (setting of base clock (f_{CLK0}))

k: Value set by the MDL04 to MDL00 bits of BRGC0 ($k = 8, 9, 10, \dots, 31$)

f_{PRS} : Peripheral hardware clock frequency

ERR: Baud rate error

(4) Permissible baud rate range during reception

The permissible error from the baud rate at the transmission destination during reception is shown below.

Caution Make sure that the baud rate error during reception is within the permissible error range, by using the calculation expression shown below.

Figure 14-12. Permissible Baud Rate Range During Reception

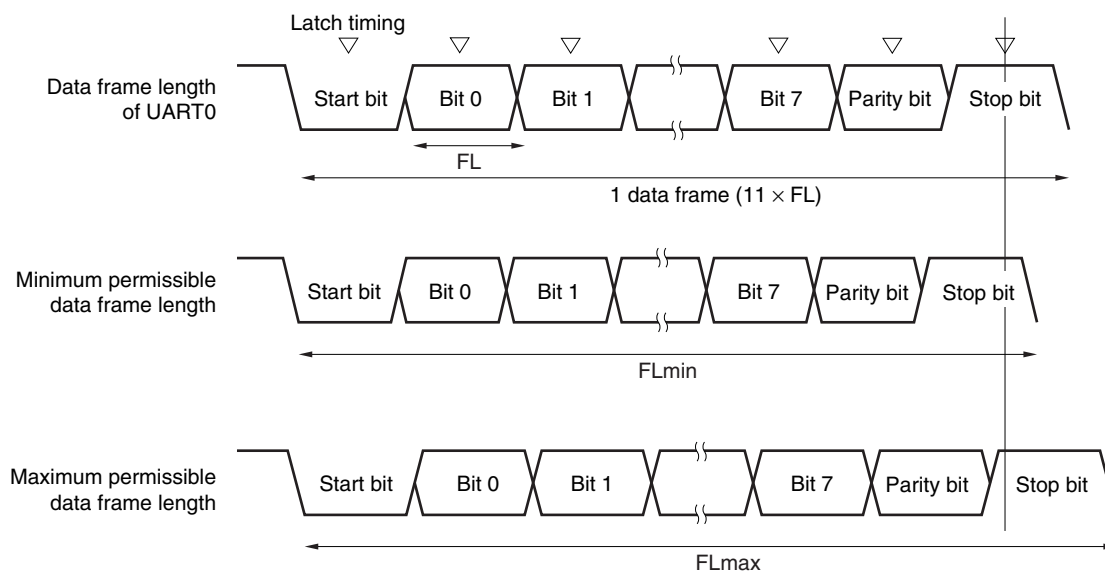

As shown in Figure 14-12, the latch timing of the receive data is determined by the counter set by baud rate generator control register 0 (BRGC0) after the start bit has been detected. If the last data (stop bit) meets this latch timing, the data can be correctly received.

Assuming that 11-bit data is received, the theoretical values can be calculated as follows.

$$FL = (\text{Brate})^{-1}$$

Brate: Baud rate of UART0

k: Set value of BRGC0

FL: 1-bit data length

Margin of latch timing: 2 clocks

$$\text{Minimum permissible data frame length: } FL_{\min} = 11 \times FL - \frac{k-2}{2k} \times FL = \frac{21k+2}{2k} FL$$

Therefore, the maximum receivable baud rate at the transmission destination is as follows.

$$BR_{\max} = (FL_{\min}/11)^{-1} = \frac{22k}{21k+2} \text{ Brate}$$

Similarly, the maximum permissible data frame length can be calculated as follows.

$$\frac{10}{11} \times FL_{\max} = 11 \times FL - \frac{k+2}{2 \times k} \times FL = \frac{21k-2}{2 \times k} FL$$

$$FL_{\max} = \frac{21k-2}{20k} FL \times 11$$

Therefore, the minimum receivable baud rate at the transmission destination is as follows.

$$BR_{\min} = (FL_{\max}/11)^{-1} = \frac{20k}{21k-2} \text{ Brate}$$

The permissible baud rate error between UART0 and the transmission destination can be calculated from the above minimum and maximum baud rate expressions, as follows.

Table 14-6. Maximum/Minimum Permissible Baud Rate Error

Division Ratio (k)	Maximum Permissible Baud Rate Error	Minimum Permissible Baud Rate Error
8	+3.53%	-3.61%
16	+4.14%	-4.19%
24	+4.34%	-4.38%
31	+4.44%	-4.47%

Remarks 1. The permissible error of reception depends on the number of bits in one frame, input clock frequency, and division ratio (k). The higher the input clock frequency and the higher the division ratio (k), the higher the permissible error.

2. k: Set value of BRGC0

CHAPTER 15 SERIAL INTERFACE UART6

15.1 Functions of Serial Interface UART6

Serial interface UART6 has the following two modes.

(1) Operation stop mode

This mode is used when serial communication is not executed and can enable a reduction in the power consumption.

For details, see **15.4.1 Operation stop mode**.

(2) Asynchronous serial interface (UART) mode

This mode supports the LIN (Local Interconnect Network)-bus. The functions of this mode are outlined below.

For details, see **15.4.2 Asynchronous serial interface (UART) mode** and **15.4.3 Dedicated baud rate generator**.

- ★
 - Maximum transfer rate: 312.5 kbps
 - Two-pin configuration TxD6: Transmit data output pin
RxD6: Receive data input pin
 - Data length of communication data can be selected from 7 or 8 bits.
 - Dedicated internal 8-bit baud rate generator allowing any baud rate to be set
 - Transmission and reception can be performed independently (full duplex operation).
 - MSB- or LSB-first communication selectable
 - Inverted transmission operation
 - Sync break field transmission from 13 to 20 bits
 - More than 11 bits can be identified for sync break field reception (SBF reception flag provided).

Cautions 1. The TxD6 output inversion function inverts only the transmission side and not the reception side. To use this function, the reception side must be ready for reception of inverted data.

2. If clock supply to serial interface UART6 is not stopped (e.g., in the HALT mode), normal operation continues. If clock supply to serial interface UART6 is stopped (e.g., in the STOP mode), each register stops operating, and holds the value immediately before clock supply was stopped. The TxD6 pin also holds the value immediately before clock supply was stopped and outputs it. However, the operation is not guaranteed after clock supply is resumed. Therefore, reset the circuit so that POWER6 = 0, RXE6 = 0, and TXE6 = 0.

3. Set POWER6 = 1 and then set TXE6 = 1 (transmission) or RXE6 = 1 (reception) to start communication.

- ★ 4. TXE6 and RXE6 are synchronized by the base clock (f_{XCLK6}) set by CKSR6. To enable transmission or reception again, set TXE6 or RXE6 to 1 at least two clocks of the base clock after TXE6 or RXE6 has been cleared to 0. If TXE6 or RXE6 is set within two clocks of the base clock, the transmission circuit or reception circuit may not be initialized.

- ★ 5. Set transmit data to TXB6 at least one base clock (f_{XCLK6}) after setting TXE6 = 1.

6. If data is continuously transmitted, the communication timing from the stop bit to the next start bit is extended two operating clocks of the macro. However, this does not affect the result of communication because the reception side initializes the timing when it has detected a start bit. Do not use the continuous transmission function if the interface is incorporated in LIN.

Remark LIN stands for Local Interconnect Network and is a low-speed (1 to 20 kbps) serial communication protocol intended to aid the cost reduction of an automotive network.

LIN communication is single-master communication, and up to 15 slaves can be connected to one master.

The LIN slaves are used to control the switches, actuators, and sensors, and these are connected to the LIN master via the LIN network.

Normally, the LIN master is connected to a network such as CAN (Controller Area Network).

In addition, the LIN bus uses a single-wire method and is connected to the nodes via a transceiver that complies with ISO9141.

In the LIN protocol, the master transmits a frame with baud rate information and the slave receives it and corrects the baud rate error. Therefore, communication is possible when the baud rate error in the slave is $\pm 15\%$ or less.

Figures 15-1 and 15-2 outline the transmission and reception operations of LIN.

Figure 15-1. LIN Transmission Operation

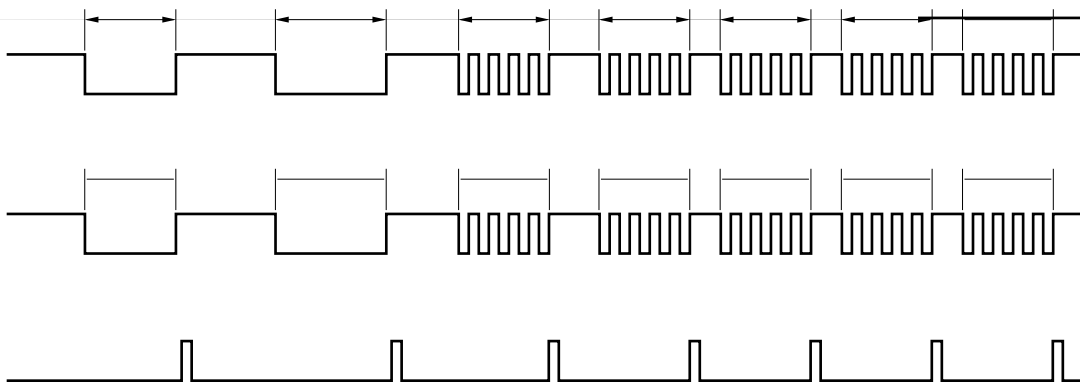
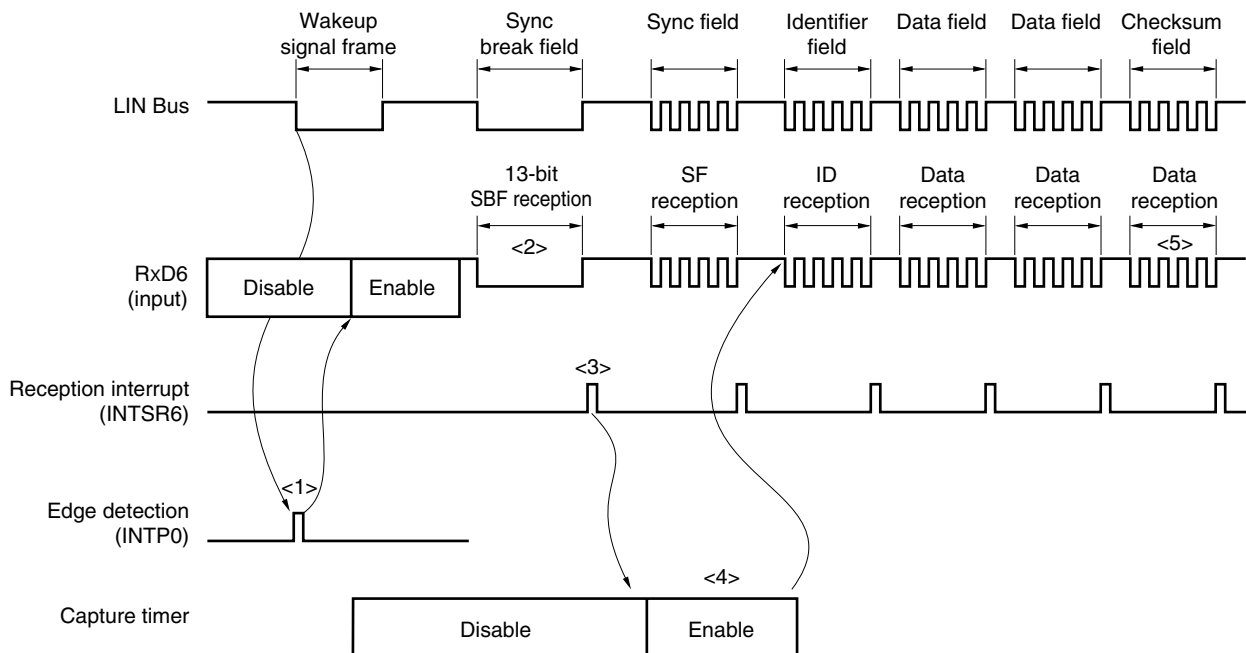

Figure 15-2. LIN Reception Operation



Reception processing is as follows.

- <1> The wakeup signal is detected at the edge of the pin, and enables UART6 and sets the SBF reception mode.
- <2> Reception continues until the STOP bit is detected. When an SBF with low-level data of 11 bits or more has been detected, it is assumed that SBF reception has been completed correctly, and an interrupt signal is output. If an SBF with low-level data of less than 11 bits has been detected, it is assumed that an SBF reception error has occurred. The interrupt signal is not output and the SBF reception mode is restored.
- <3> If SBF reception has been completed correctly, an interrupt signal is output. Start 16-bit timer/event counter 00 by the SBF reception end interrupt servicing and measure the bit interval (pulse width) of the sync field (see **7.4.8 Pulse width measurement operation**). Detection of errors OVE6, PE6, and FE6 is suppressed, and error detection processing of UART communication and data transfer of the shift register and RXB6 is not performed. The shift register holds the reset value FFH.
- <4> Calculate the baud rate error from the bit interval of the sync field, disable UART6 after SF reception, and then re-set baud rate generator control register 6 (BRGC6).
- <5> Distinguish the checksum field by software. Also perform processing by software to initialize UART6 after reception of the checksum field and to set the SBF reception mode again.

Figure 15-3 shows the port configuration for LIN reception operation.

The wakeup signal transmitted from the LIN master is received by detecting the edge of the external interrupt (INTP0). The length of the sync field transmitted from the LIN master can be measured using the external event capture operation of 16-bit timer/event counter 00, and the baud rate error can be calculated.

The input source of the reception port input (RxD6) can be input to the external interrupt (INTP0) and 16-bit timer/event counter 00 by port input switch control (ISC0/ISC1), without connecting RxD6 and INTP0/TI000 externally.

Figure 15-3. Port Configuration for LIN Reception Operation

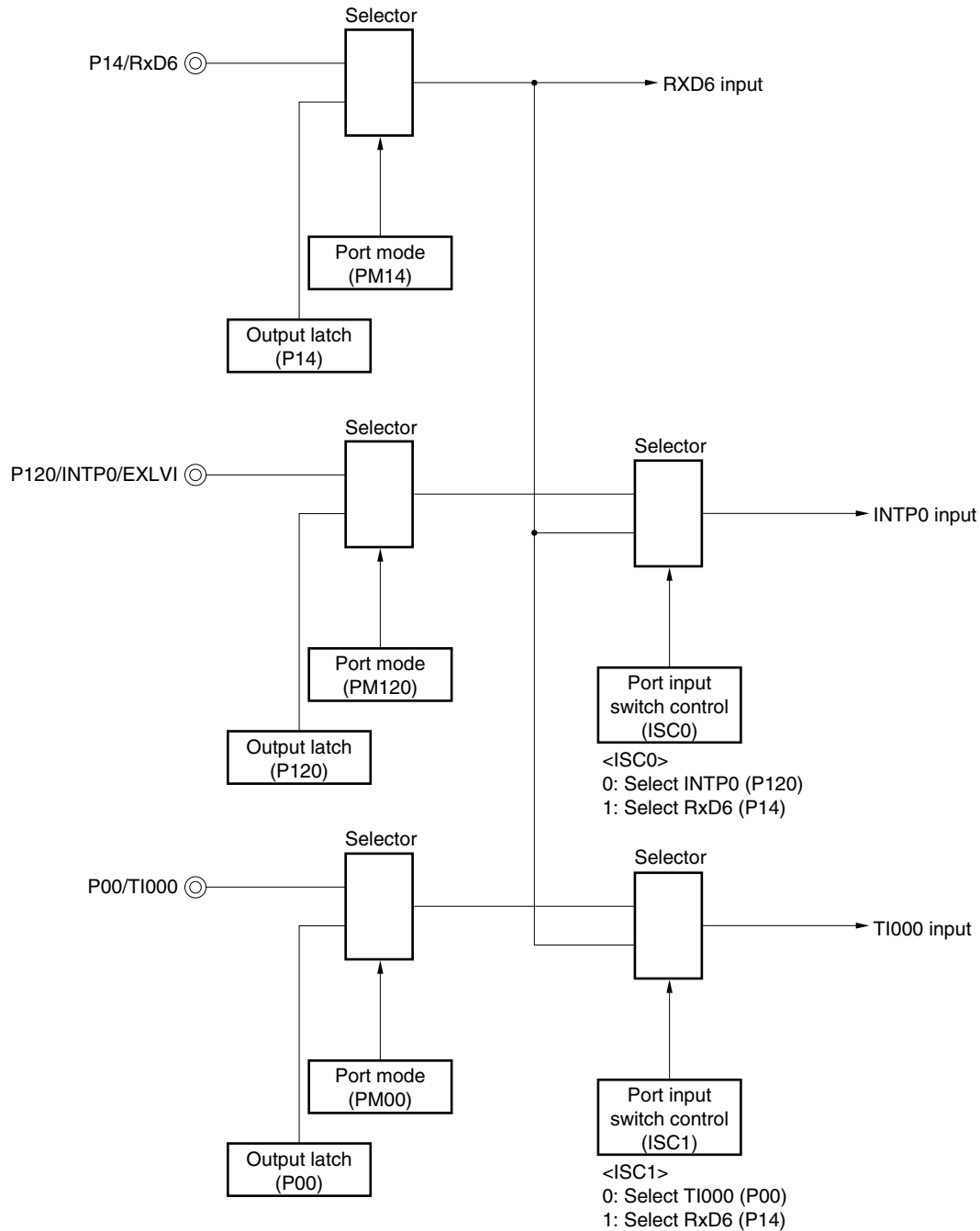

Remark ISC0, ISC1: Bits 0 and 1 of the input switch control register (ISC) (see **Figure 15-11**)

The peripheral functions used in the LIN communication operation are shown below.

<Peripheral functions used>

- External interrupt (INTP0); wakeup signal detection
Use: Detects the wakeup signal edges and detects start of communication.
- 16-bit timer/event counter 00 (TI000); baud rate error detection
Use: Detects the baud rate error (measures the TI000 input edge interval in the capture mode) by detecting the sync field (SF) length and divides it by the number of bits.
- Serial interface UART6

15.2 Configuration of Serial Interface UART6

Serial interface UART6 includes the following hardware.

Table 15-1. Configuration of Serial Interface UART6

Item	Configuration
Registers	Receive buffer register 6 (RXB6) Receive shift register 6 (RXS6) Transmit buffer register 6 (TXB6) Transmit shift register 6 (TXS6)
Control registers	Asynchronous serial interface operation mode register 6 (ASIM6) Asynchronous serial interface reception error status register 6 (ASIS6) Asynchronous serial interface transmission status register 6 (ASIF6) Clock selection register 6 (CKSR6) Baud rate generator control register 6 (BRGC6) Asynchronous serial interface control register 6 (ASICL6) Input switch control register (ISC) Port mode register 1 (PM1) Port register 1 (P1)

Figure 15-4. Block Diagram of Serial Interface UART6

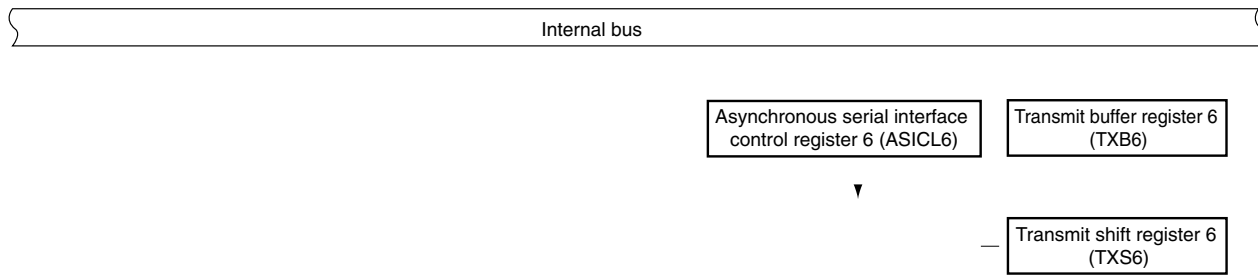

©

(1) Receive buffer register 6 (RXB6)

This 8-bit register stores parallel data converted by receive shift register 6 (RXS6).

Each time 1 byte of data has been received, new receive data is transferred to this register from RXS6. If the data length is set to 7 bits, data is transferred as follows.

- In LSB-first reception, the receive data is transferred to bits 0 to 6 of RXB6 and the MSB of RXB6 is always 0.
- In MSB-first reception, the receive data is transferred to bits 1 to 7 of RXB6 and the LSB of RXB6 is always 0.

If an overrun error (OVE6) occurs, the receive data is not transferred to RXB6.

RXB6 can be read by an 8-bit memory manipulation instruction. No data can be written to this register.

Reset signal generation sets this register to FFH.

(2) Receive shift register 6 (RXS6)

This register converts the serial data input to the RxD6 pin into parallel data.

RXS6 cannot be directly manipulated by a program.

(3) Transmit buffer register 6 (TXB6)

This buffer register is used to set transmit data. Transmission is started when data is written to TXB6.

This register can be read or written by an 8-bit memory manipulation instruction.

Reset signal generation sets this register to FFH.

Cautions 1. Do not write data to TXB6 when bit 1 (TXBF6) of asynchronous serial interface transmission status register 6 (ASIF6) is 1.

2. Do not refresh (write the same value to) TXB6 by software during a communication operation (when bit 7 (POWER6) and bit 6 (TXE6) of asynchronous serial interface operation mode register 6 (ASIM6) are 1 or when bit 7 (POWER6) and bit 5 (RXE6) of ASIM6 are 1).

★

3. Set transmit data to TXB6 at least one base clock (f_{CLK6}) after setting TXE6 = 1.

(4) Transmit shift register 6 (TXS6)

This register transmits the data transferred from TXB6 from the TxD6 pin as serial data. Data is transferred from TXB6 immediately after TXB6 is written for the first transmission, or immediately before INTST6 occurs after one frame was transmitted for continuous transmission. Data is transferred from TXB6 and transmitted from the TxD6 pin at the falling edge of the base clock.

TXS6 cannot be directly manipulated by a program.

15.3 Registers Controlling Serial Interface UART6

Serial interface UART6 is controlled by the following nine registers.

- Asynchronous serial interface operation mode register 6 (ASIM6)
- Asynchronous serial interface reception error status register 6 (ASIS6)
- Asynchronous serial interface transmission status register 6 (ASIF6)
- Clock selection register 6 (CKSR6)
- Baud rate generator control register 6 (BRGC6)
- Asynchronous serial interface control register 6 (ASICL6)
- Input switch control register (ISC)
- Port mode register 1 (PM1)
- Port register 1 (P1)

(1) Asynchronous serial interface operation mode register 6 (ASIM6)

This 8-bit register controls the serial communication operations of serial interface UART6.

This register can be set by a 1-bit or 8-bit memory manipulation instruction.

Reset signal generation sets this register to 01H.

Remark ASIM6 can be refreshed (the same value is written) by software during a communication operation (when bit 7 (POWER6) and bit 6 (TXE6) of ASIM6 = 1 or bit 7 (POWER6) and bit 5 (RXE6) of ASIM6 = 1).

Figure 15-5. Format of Asynchronous Serial Interface Operation Mode Register 6 (ASIM6) (1/2)

Address: FF50H After reset: 01H R/W

Symbol	<7>	<6>	<5>	4	3	2	1	0
ASIM6	POWER6	TXE6	RXE6	PS61	PS60	CL6	SL6	ISRM6
POWER6	Enables/disables operation of internal operation clock							
0 ^{Note 1}	Disables operation of the internal operation clock (fixes the clock to low level) and asynchronously resets the internal circuit ^{Note 2} .							
1	Enables operation of the internal operation clock							
TXE6	Enables/disables transmission							
0	Disables transmission (synchronously resets the transmission circuit).							
1	Enables transmission							
RXE6	Enables/disables reception							
0	Disables reception (synchronously resets the reception circuit).							
1	Enables reception							

- Notes**
1. The output of the TxD6 pin goes high level and the input from the RxD6 pin is fixed to the high level when POWER6 = 0 during transmission.
 2. Asynchronous serial interface reception error status register 6 (ASIS6), asynchronous serial interface transmission status register 6 (ASIF6), bit 7 (SBRF6) and bit 6 (SBRT6) of asynchronous serial interface control register 6 (ASICL6), and receive buffer register 6 (RXB6) are reset.

Figure 15-5. Format of Asynchronous Serial Interface Operation Mode Register 6 (ASIM6) (2/2)

PS61	PS60	Transmission operation	Reception operation
0	0	Does not output parity bit.	Reception without parity
0	1	Outputs 0 parity.	Reception as 0 parity ^{Note}
1	0	Outputs odd parity.	Judges as odd parity.
1	1	Outputs even parity.	Judges as even parity.

CL6	Specifies character length of transmit/receive data
0	Character length of data = 7 bits
1	Character length of data = 8 bits

SL6	Specifies number of stop bits of transmit data
0	Number of stop bits = 1
1	Number of stop bits = 2

ISRM6	Enables/disables occurrence of reception completion interrupt in case of error
0	“INTSRE6” occurs in case of error (at this time, INTSR6 does not occur).
1	“INTSR6” occurs in case of error (at this time, INTSRE6 does not occur).

Note If “reception as 0 parity” is selected, the parity is not judged. Therefore, bit 2 (PE6) of asynchronous serial interface reception error status register 6 (ASIS6) is not set and the error interrupt does not occur.

- Cautions**
1. To start the transmission, set POWER6 to 1 and then set TXE6 to 1. To stop the transmission, clear TXE6 to 0, and then clear POWER6 to 0.
 2. To start the reception, set POWER6 to 1 and then set RXE6 to 1. To stop the reception, clear RXE6 to 0, and then clear POWER6 to 0.
 3. Set POWER6 to 1 and then set RXE6 to 1 while a high level is input to the RxD6 pin. If POWER6 is set to 1 and RXE6 is set to 1 while a low level is input, reception is started.
 4. TXE6 and RXE6 are synchronized by the base clock (f_{XCLK6}) set by CKSR6. To enable transmission or reception again, set TXE6 or RXE6 to 1 at least two clocks of the base clock after TXE6 or RXE6 has been cleared to 0. If TXE6 or RXE6 is set within two clocks of the base clock, the transmission circuit or reception circuit may not be initialized.
 5. Set transmit data to TXB6 at least one base clock (f_{XCLK6}) after setting TXE6 = 1.
 6. Clear the TXE6 and RXE6 bits to 0 before rewriting the PS61, PS60, and CL6 bits.
 7. Fix the PS61 and PS60 bits to 0 when mounting the device on LIN.
 8. Clear TXE6 to 0 before rewriting the SL6 bit. Reception is always performed with “the number of stop bits = 1”, and therefore, is not affected by the set value of the SL6 bit.
 9. Make sure that RXE6 = 0 when rewriting the ISRM6 bit.

(2) Asynchronous serial interface reception error status register 6 (ASIS6)

This register indicates an error status on completion of reception by serial interface UART6. It includes three error flag bits (PE6, FE6, OVE6).

This register is read-only by an 8-bit memory manipulation instruction.

Reset signal generation sets this register to 00H if bit 7 (POWER6) and bit 5 (RXE6) of ASIM6 = 0. 00H is read when this register is read. If a reception error occurs, read ASIS6 and then read receive buffer register 6 (RXB6) to clear the error flag.

Figure 15-6. Format of Asynchronous Serial Interface Reception Error Status Register 6 (ASIS6)

Address: FF53H After reset: 00H R

Symbol	7	6	5	4	3	2	1	0
ASIS6	0	0	0	0	0	PE6	FE6	OVE6

PE6	Status flag indicating parity error
0	If POWER6 = 0 and RXE6 = 0, or if ASIS6 register is read
1	If the parity of transmit data does not match the parity bit on completion of reception

FE6	Status flag indicating framing error
0	If POWER6 = 0 and RXE6 = 0, or if ASIS6 register is read
1	If the stop bit is not detected on completion of reception

OVE6	Status flag indicating overrun error
0	If POWER6 = 0 and RXE6 = 0, or if ASIS6 register is read
1	If receive data is set to the RXB6 register and the next reception operation is completed before the data is read.

- Cautions**
1. The operation of the PE6 bit differs depending on the set values of the PS61 and PS60 bits of asynchronous serial interface operation mode register 6 (ASIM6).
 2. The first bit of the receive data is checked as the stop bit, regardless of the number of stop bits.
 3. If an overrun error occurs, the next receive data is not written to receive buffer register 6 (RXB6) but discarded.
 4. If data is read from ASIS6, a wait cycle is generated. Do not read data from ASIS6 when the CPU is operating on the subsystem clock and the peripheral hardware clock is stopped. For details, see CHAPTER 31 CAUTIONS FOR WAIT.

(3) Asynchronous serial interface transmission status register 6 (ASIF6)

This register indicates the status of transmission by serial interface UART6. It includes two status flag bits (TXBF6 and TXSF6).

Transmission can be continued without disruption even during an interrupt period, by writing the next data to the TXB6 register after data has been transferred from the TXB6 register to the TXS6 register.

This register is read-only by an 8-bit memory manipulation instruction.

Reset signal generation sets this register to 00H if bit 7 (POWER6) and bit 6 (TXE6) of ASIM6 = 0.

Figure 15-7. Format of Asynchronous Serial Interface Transmission Status Register 6 (ASIF6)

Address: FF55H After reset: 00H R

Symbol	7	6	5	4	3	2	1	0
ASIF6	0	0	0	0	0	0	TXBF6	TXSF6

TXBF6	Transmit buffer data flag
0	If POWER6 = 0 or TXE6 = 0, or if data is transferred to transmit shift register 6 (TXS6)
1	If data is written to transmit buffer register 6 (TXB6) (if data exists in TXB6)

TXSF6	Transmit shift register data flag
0	If POWER6 = 0 or TXE6 = 0, or if the next data is not transferred from transmit buffer register 6 (TXB6) after completion of transfer
1	If data is transferred from transmit buffer register 6 (TXB6) (if data transmission is in progress)

- Cautions**
- 1. To transmit data continuously, write the first transmit data (first byte) to the TXB6 register. Be sure to check that the TXBF6 flag is “0”. If so, write the next transmit data (second byte) to the TXB6 register. If data is written to the TXB6 register while the TXBF6 flag is “1”, the transmit data cannot be guaranteed.**
 - 2. To initialize the transmission unit upon completion of continuous transmission, be sure to check that the TXSF6 flag is “0” after generation of the transmission completion interrupt, and then execute initialization. If initialization is executed while the TXSF6 flag is “1”, the transmit data cannot be guaranteed.**

(4) Clock selection register 6 (CKSR6)

This register selects the base clock of serial interface UART6.

CKSR6 can be set by an 8-bit memory manipulation instruction.

Reset signal generation sets this register to 00H.

Remark CKSR6 can be refreshed (the same value is written) by software during a communication operation (when bit 7 (POWER6) and bit 6 (TXE6) of ASIM6 = 1 or bit 7 (POWER6) and bit 5 (RXE6) of ASIM6 = 1).

Figure 15-8. Format of Clock Selection Register 6 (CKSR6)

Address: FF56H After reset: 00H R/W

Symbol	7	6	5	4	3	2	1	0
CKSR6	0	0	0	0	TPS63	TPS62	TPS61	TPS60

TPS63	TPS62	TPS61	TPS60		Base clock (f _{CLK6}) selection			
					f _{PRS} = 2 MHz	f _{PRS} = 5 MHz	f _{PRS} = 10 MHz	f _{PRS} = 20 MHz
0	0	0	0	f _{PRS}	2 MHz	5 MHz	10 MHz	20 MHz
0	0	0	1	f _{PRS} /2	1 MHz	2.5 MHz	5 MHz	10 MHz
0	0	1	0	f _{PRS} /2 ²	500 kHz	1.25 MHz	2.5 MHz	5 MHz
0	0	1	1	f _{PRS} /2 ³	250 kHz	625 kHz	1.25 MHz	2.5 MHz
0	1	0	0	f _{PRS} /2 ⁴	125 kHz	312.5 kHz	625 kHz	1.25 MHz
0	1	0	1	f _{PRS} /2 ⁵	62.5 kHz	156.25 kHz	312.5 kHz	625 kHz
0	1	1	0	f _{PRS} /2 ⁶	31.25 kHz	78.13 kHz	156.25 kHz	312.5 kHz
0	1	1	1	f _{PRS} /2 ⁷	15.625 kHz	39.06 kHz	78.13 kHz	156.25 kHz
1	0	0	0	f _{PRS} /2 ⁸	7.813 kHz	19.53 kHz	39.06 kHz	78.13 kHz
1	0	0	1	f _{PRS} /2 ⁹	3.906 kHz	9.77 kHz	19.53 kHz	39.06 kHz
1	0	1	0	f _{PRS} /2 ¹⁰	1.953 kHz	4.88 kHz	9.77 kHz	19.53 kHz
1	0	1	1	TM50 output ^{Note}				
Other than above				Setting prohibited				

Note Note the following points when selecting the TM50 output as the base clock.

- Mode in which the count clock is cleared and started upon a match of TM50 and CR50 (TMC506 = 0)
Start the operation of 8-bit timer/event counter 50 first and then enable the timer F/F inversion operation (TMC501 = 1).
- PWM mode (TMC506 = 1)
Start the operation of 8-bit timer/event counter 50 first and then set the count clock to make the duty = 50%.
It is not necessary to enable the TO50 pin as a timer output pin in any mode.

Caution Make sure POWER6 = 0 when rewriting TPS63 to TPS60.

- Remarks**
1. f_{PRS}: Peripheral hardware clock frequency
 2. TMC506: Bit 6 of 8-bit timer mode control register 50 (TMC50)
TMC501: Bit 1 of TMC50

(5) Baud rate generator control register 6 (BRGC6)

This register sets the division value of the 8-bit counter of serial interface UART6.

BRGC6 can be set by an 8-bit memory manipulation instruction.

Reset signal generation sets this register to FFH.

Remark BRGC6 can be refreshed (the same value is written) by software during a communication operation (when bit 7 (POWER6) and bit 6 (TXE6) of ASIM6 = 1 or bit 7 (POWER6) and bit 5 (RXE6) of ASIM6 = 1).

Figure 15-9. Format of Baud Rate Generator Control Register 6 (BRGC6)

Address: FF57H After reset: FFH R/W

Symbol	7	6	5	4	3	2	1	0
BRGC6	MDL67	MDL66	MDL65	MDL64	MDL63	MDL62	MDL61	MDL60

MDL67	MDL66	MDL65	MDL64	MDL63	MDL62	MDL61	MDL60	k	Output clock selection of 8-bit counter
0	0	0	0	0	×	×	×	×	Setting prohibited
0	0	0	0	1	0	0	0	8	$f_{CLK6}/8$
0	0	0	0	1	0	0	1	9	$f_{CLK6}/9$
0	0	0	0	1	0	1	0	10	$f_{CLK6}/10$
•	•	•	•	•	•	•	•	•	•
•	•	•	•	•	•	•	•	•	•
•	•	•	•	•	•	•	•	•	•
•	•	•	•	•	•	•	•	•	•
•	•	•	•	•	•	•	•	•	•
1	1	1	1	1	1	0	0	252	$f_{CLK6}/252$
1	1	1	1	1	1	0	1	253	$f_{CLK6}/253$
1	1	1	1	1	1	1	0	254	$f_{CLK6}/254$
1	1	1	1	1	1	1	1	255	$f_{CLK6}/255$

- Cautions**
1. Make sure that bit 6 (TXE6) and bit 5 (RXE6) of the ASIM6 register = 0 when rewriting the MDL67 to MDL60 bits.
 2. The baud rate is the output clock of the 8-bit counter divided by 2.

- Remarks**
1. f_{CLK6} : Frequency of base clock selected by the TPS63 to TPS60 bits of CKSR6 register
 2. k: Value set by MDL67 to MDL60 bits (k = 8, 9, 10, ..., 255)
 3. ×: Don't care

(6) Asynchronous serial interface control register 6 (ASICL6)

This register controls the serial communication operations of serial interface UART6.

ASICL6 can be set by a 1-bit or 8-bit memory manipulation instruction.

Reset signal generation sets this register to 16H.

Caution ASICL6 can be refreshed (the same value is written) by software during a communication operation (when bit 7 (POWER6) and bit 6 (TXE6) of ASIM6 = 1 or bit 7 (POWER6) and bit 5 (RXE6) of ASIM6 = 1). However, do not set both SBRT6 and SBTT6 to 1 by a refresh operation during SBF reception (SBRT6 = 1) or SBF transmission (until INTST6 occurs since SBTT6 has been set (1)), because it may re-trigger SBF reception or SBF transmission.

Figure 15-10. Format of Asynchronous Serial Interface Control Register 6 (ASICL6) (1/2)

Address: FF58H After reset: 16H R/W^{Note}

Symbol	<7>	<6>	5	4	3	2	1	0
ASICL6	SBRF6	SBRT6	SBTT6	SBL62	SBL61	SBL60	DIR6	TXDLV6

SBRF6	SBF reception status flag
0	If POWER6 = 0 and RXE6 = 0 or if SBF reception has been completed correctly
1	SBF reception in progress

SBRT6	SBF reception trigger
0	–
1	SBF reception trigger

SBTT6	SBF transmission trigger
0	–
1	SBF transmission trigger

Note Bit 7 is read-only.

Figure 15-10. Format of Asynchronous Serial Interface Control Register 6 (ASICL6) (2/2)

SBL62	SBL61	SBL60	SBF transmission output width control
1	0	1	SBF is output with 13-bit length.
1	1	0	SBF is output with 14-bit length.
1	1	1	SBF is output with 15-bit length.
0	0	0	SBF is output with 16-bit length.
0	0	1	SBF is output with 17-bit length.
0	1	0	SBF is output with 18-bit length.
0	1	1	SBF is output with 19-bit length.
1	0	0	SBF is output with 20-bit length.

DIR6	First-bit specification
0	MSB
1	LSB

TXDLV6	Enables/disables inverting TxD6 output
0	Normal output of TxD6
1	Inverted output of TxD6

- Cautions**
1. In the case of an SBF reception error, the mode returns to the SBF reception mode. The status of the SBRF6 flag is held (1).
 2. Before setting the SBRT6 bit, make sure that bit 7 (POWER6) and bit 5 (RXE6) of ASIM6 = 1. After setting the SBRT6 bit to 1, do not clear it to 0 before SBF reception is completed (before an interrupt request signal is generated).
 3. The read value of the SBRT6 bit is always 0. SBRT6 is automatically cleared to 0 after SBF reception has been correctly completed.
 4. Before setting the SBTT6 bit to 1, make sure that bit 7 (POWER6) and bit 6 (TXE6) of ASIM6 = 1. After setting the SBTT6 bit to 1, do not clear it to 0 before SBF transmission is completed (before an interrupt request signal is generated).
 5. The read value of the SBTT6 bit is always 0. SBTT6 is automatically cleared to 0 at the end of SBF transmission.
 6. Do not set the SBRT6 bit to 1 during reception, and do not set the SBTT6 bit to 1 during transmission.
 7. Before rewriting the DIR6 and TXDLV6 bits, clear the TXE6 and RXE6 bits to 0.

★

(7) Input switch control register (ISC)

The input switch control register (ISC) is used to receive a status signal transmitted from the master during LIN (Local Interconnect Network) reception.

- ★ The signal input from the P14/RxD6 pin is selected as the input source of INTP0 and TI000 when ISC0 and ISC1 are set to 1.

This register can be set by a 1-bit or 8-bit memory manipulation instruction.

Reset signal generation sets this register to 00H.

Figure 15-11. Format of Input Switch Control Register (ISC)

Address: FF4FH After reset: 00H R/W

Symbol	7	6	5	4	3	2	1	0
ISC	0	0	0	0	0	0	ISC1	ISC0

ISC1	TI000 input source selection
0	TI000 (P00)
1	RxD6 (P14)

ISC0	INTP0 input source selection
0	INTP0 (P120)
1	RxD6 (P14)

(8) Port mode register 1 (PM1)

This register sets port 1 input/output in 1-bit units.

When using the P13/TxD6 pin for serial interface data output, clear PM13 to 0 and set the output latch of P13 to 1. When using the P14/RxD6 pin for serial interface data input, set PM14 to 1. The output latch of P14 at this time may be 0 or 1.

PM1 can be set by a 1-bit or 8-bit memory manipulation instruction.

Reset signal generation sets this register to FFH.

Figure 15-12. Format of Port Mode Register 1 (PM1)

Address: FF21H After reset: FFH R/W

Symbol	7	6	5	4	3	2	1	0
PM1	PM17	PM16	PM15	PM14	PM13	PM12	PM11	PM10

PM1n	P1n pin I/O mode selection (n = 0 to 7)
0	Output mode (output buffer on)
1	Input mode (output buffer off)

15.4 Operation of Serial Interface UART6

Serial interface UART6 has the following two modes.

- Operation stop mode
- Asynchronous serial interface (UART) mode

15.4.1 Operation stop mode

In this mode, serial communication cannot be executed; therefore, the power consumption can be reduced. In addition, the pins can be used as ordinary port pins in this mode. To set the operation stop mode, clear bits 7, 6, and 5 (POWER6, TXE6, and RXE6) of ASIM6 to 0.

(1) Register used

The operation stop mode is set by asynchronous serial interface operation mode register 6 (ASIM6).

ASIM6 can be set by a 1-bit or 8-bit memory manipulation instruction.

Reset signal generation sets this register to 01H.

Address: FF50H After reset: 01H R/W

Symbol	<7>	<6>	<5>	4	3	2	1	0
ASIM6	POWER6	TXE6	RXE6	PS61	PS60	CL6	SL6	ISRM6
	POWER6	Enables/disables operation of internal operation clock						
	0 ^{Note 1}	Disables operation of the internal operation clock (fixes the clock to low level) and asynchronously resets the internal circuit ^{Note 2} .						
	TXE6	Enables/disables transmission						
	0	Disables transmission operation (synchronously resets the transmission circuit).						
	RXE6	Enables/disables reception						
	0	Disables reception (synchronously resets the reception circuit).						

- Notes**
1. The output of the TxD6 pin goes high and the input from the RxD6 pin is fixed to high level when POWER6 = 0 during transmission.
 2. Asynchronous serial interface reception error status register 6 (ASIS6), asynchronous serial interface transmission status register 6 (ASIF6), bit 7 (SBRF6) and bit 6 (SBRT6) of asynchronous serial interface control register 6 (ASICL6), and receive buffer register 6 (RXB6) are reset.

Caution Clear POWER6 to 0 after clearing TXE6 and RXE6 to 0 to stop the operation.
To start the communication, set POWER6 to 1, and then set TXE6 or RXE6 to 1.

Remark To use the RxD6/P14 and TxD6/P13 pins as general-purpose port pins, see **CHAPTER 5 PORT FUNCTIONS**.

15.4.2 Asynchronous serial interface (UART) mode

In this mode, data of 1 byte is transmitted/received following a start bit, and a full-duplex operation can be performed.

A dedicated UART baud rate generator is incorporated, so that communication can be executed at a wide range of baud rates.

(1) Registers used

- Asynchronous serial interface operation mode register 6 (ASIM6)
- Asynchronous serial interface reception error status register 6 (ASIS6)
- Asynchronous serial interface transmission status register 6 (ASIF6)
- Clock selection register 6 (CKSR6)
- Baud rate generator control register 6 (BRGC6)
- Asynchronous serial interface control register 6 (ASICL6)
- Input switch control register (ISC)
- Port mode register 1 (PM1)
- Port register 1 (P1)

The basic procedure of setting an operation in the UART mode is as follows.

- <1> Set the CKSR6 register (see **Figure 15-8**).
- <2> Set the BRGC6 register (see **Figure 15-9**).
- <3> Set bits 0 to 4 (ISRM6, SL6, CL6, PS60, PS61) of the ASIM6 register (see **Figure 15-5**).
- <4> Set bits 0 and 1 (TXDLV6, DIR6) of the ASICL6 register (see **Figure 15-10**).
- <5> Set bit 7 (POWER6) of the ASIM6 register to 1.
- <6> Set bit 6 (TXE6) of the ASIM6 register to 1. → Transmission is enabled.
Set bit 5 (RXE6) of the ASIM6 register to 1. → Reception is enabled.
- <7> Write data to transmit buffer register 6 (TXB6). → Data transmission is started.

Caution Take relationship with the other party of communication when setting the port mode register and port register.

The relationship between the register settings and pins is shown below.

Table 15-2. Relationship Between Register Settings and Pins

POWER6	TXE6	RXE6	PM13	P13	PM14	P14	UART6 Operation	Pin Function	
								TxD6/P13	RxD6/P14
0	0	0	×	×	×	×	Stop	P13	P14
1	0	1	×	×	1	×	Reception	P13	RxD6
	1	0	0	1	×	×	Transmission	TxD6	P14
	1	1	0	1	1	×	Transmission/ reception	TxD6	RxD6

Note Can be set as port function.

Remark ×: don't care

POWER6: Bit 7 of asynchronous serial interface operation mode register 6 (ASIM6)

TXE6: Bit 6 of ASIM6

RXE6: Bit 5 of ASIM6

PM1×: Port mode register

P1×: Port output latch

(2) Communication operation**(a) Format and waveform example of normal transmit/receive data**

Figures 15-13 and 15-14 show the format and waveform example of the normal transmit/receive data.

Figure 15-13. Format of Normal UART Transmit/Receive Data

1. LSB-first transmission/reception**2. MSB-first transmission/reception**

One data frame consists of the following bits.

- Start bit ... 1 bit
- Character bits ... 7 or 8 bits
- Parity bit ... Even parity, odd parity, 0 parity, or no parity
- Stop bit ... 1 or 2 bits

The character bit length, parity, and stop bit length in one data frame are specified by asynchronous serial interface operation mode register 6 (ASIM6).

Whether data is communicated with the LSB or MSB first is specified by bit 1 (DIR6) of asynchronous serial interface control register 6 (ASICL6).

Whether the TxD6 pin outputs normal or inverted data is specified by bit 0 (TXDLV6) of ASICL6.

Figure 15-14. Example of Normal UART Transmit/Receive Data Waveform

1. Data length: 8 bits, LSB first, Parity: Even parity, Stop bit: 1 bit, Communication data: 55H

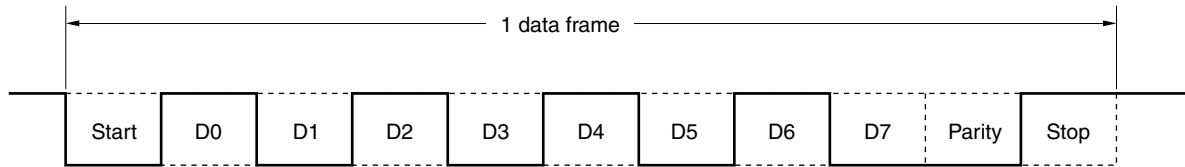

2. Data length: 8 bits, MSB first, Parity: Even parity, Stop bit: 1 bit, Communication data: 55H

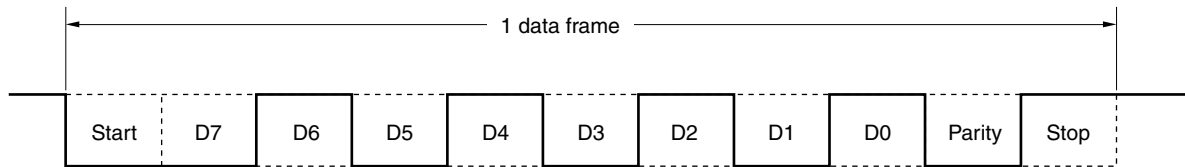

3. Data length: 8 bits, MSB first, Parity: Even parity, Stop bit: 1 bit, Communication data: 55H, Tx/D6 pin inverted output

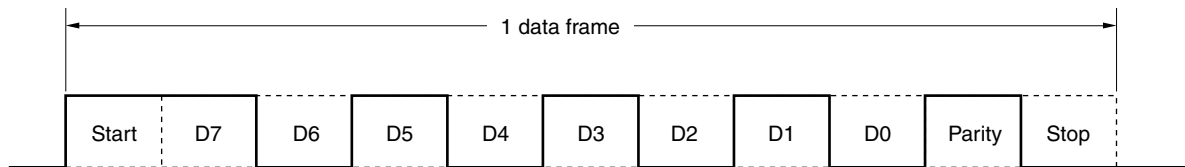

4. Data length: 7 bits, LSB first, Parity: Odd parity, Stop bit: 2 bits, Communication data: 36H

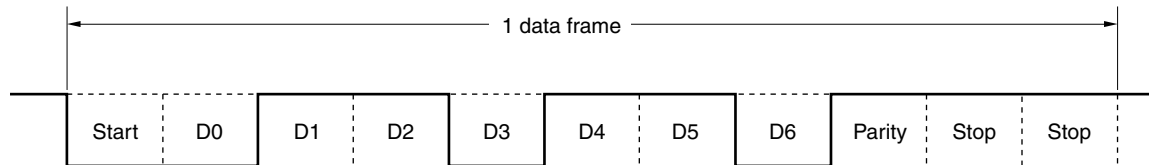

5. Data length: 8 bits, LSB first, Parity: None, Stop bit: 1 bit, Communication data: 87H

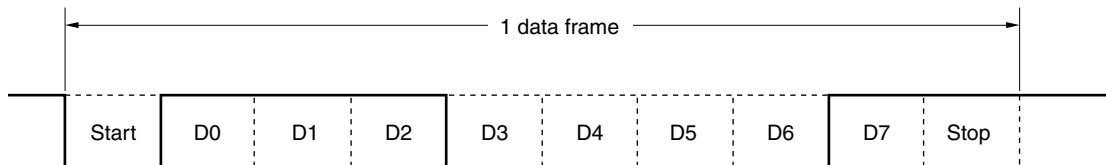

(b) Parity types and operation

The parity bit is used to detect a bit error in communication data. Usually, the same type of parity bit is used on both the transmission and reception sides. With even parity and odd parity, a 1-bit (odd number) error can be detected. With zero parity and no parity, an error cannot be detected.

Caution Fix the PS61 and PS60 bits to 0 when the device is incorporated in LIN.

(i) Even parity

- Transmission

Transmit data, including the parity bit, is controlled so that the number of bits that are “1” is even. The value of the parity bit is as follows.

If transmit data has an odd number of bits that are “1”: 1
If transmit data has an even number of bits that are “1”: 0

- Reception

The number of bits that are “1” in the receive data, including the parity bit, is counted. If it is odd, a parity error occurs.

(ii) Odd parity

- Transmission

Unlike even parity, transmit data, including the parity bit, is controlled so that the number of bits that are “1” is odd.

If transmit data has an odd number of bits that are “1”: 0
If transmit data has an even number of bits that are “1”: 1

- Reception

The number of bits that are “1” in the receive data, including the parity bit, is counted. If it is even, a parity error occurs.

(iii) 0 parity

The parity bit is cleared to 0 when data is transmitted, regardless of the transmit data.

The parity bit is not detected when the data is received. Therefore, a parity error does not occur regardless of whether the parity bit is “0” or “1”.

(iv) No parity

No parity bit is appended to the transmit data.

Reception is performed assuming that there is no parity bit when data is received. Because there is no parity bit, a parity error does not occur.

(c) Normal transmission

When bit 7 (POWER6) of asynchronous serial interface operation mode register 6 (ASIM6) is set to 1 and bit 6 (TXE6) of ASIM6 is then set to 1, transmission is enabled. Transmission can be started by writing transmit data to transmit buffer register 6 (TXB6). The start bit, parity bit, and stop bit are automatically appended to the data.

When transmission is started, the data in TXB6 is transferred to transmit shift register 6 (TXS6). After that, the transmit data is sequentially output from TXS6 to the TxD6 pin. When transmission is completed, the parity and stop bits set by ASIM6 are appended and a transmission completion interrupt request (INTST6) is generated.

Transmission is stopped until the data to be transmitted next is written to TXB6.

Figure 15-15 shows the timing of the transmission completion interrupt request (INTST6). This interrupt occurs as soon as the last stop bit has been output.

Figure 15-15. Normal Transmission Completion Interrupt Request Timing

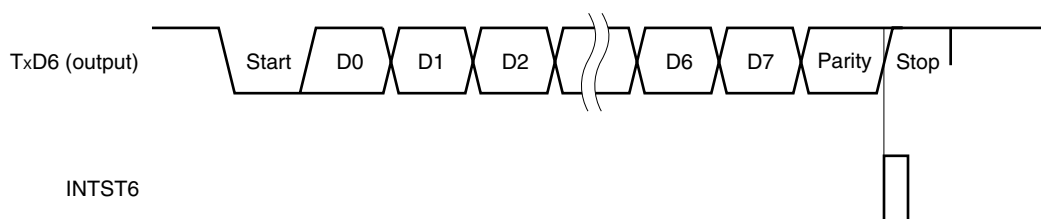
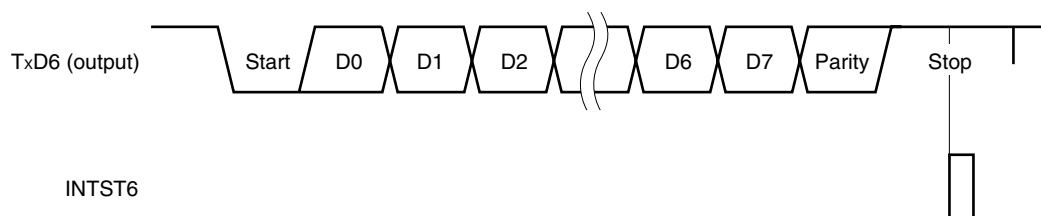
1. Stop bit length: 1**2. Stop bit length: 2**

(d) Continuous transmission

The next transmit data can be written to transmit buffer register 6 (TXB6) as soon as transmit shift register 6 (TXS6) has started its shift operation. Consequently, even while the INTST6 interrupt is being serviced after transmission of one data frame, data can be continuously transmitted and an efficient communication rate can be realized. In addition, the TXB6 register can be efficiently written twice (2 bytes) without having to wait for the transmission time of one data frame, by reading bit 0 (TXSF6) of asynchronous serial interface transmission status register 6 (ASIF6) when the transmission completion interrupt has occurred.

To transmit data continuously, be sure to reference the ASIF6 register to check the transmission status and whether the TXB6 register can be written, and then write the data.

- Cautions**
1. The TXBF6 and TXSF6 flags of the ASIF6 register change from “10” to “11”, and to “01” during continuous transmission. To check the status, therefore, do not use a combination of the TXBF6 and TXSF6 flags for judgment. Read only the TXBF6 flag when executing continuous transmission.
 2. When the device is incorporated in a LIN, the continuous transmission function cannot be used. Make sure that asynchronous serial interface transmission status register 6 (ASIF6) is 00H before writing transmit data to transmit buffer register 6 (TXB6).

TXBF6	Writing to TXB6 Register
0	Writing enabled
1	Writing disabled

Caution To transmit data continuously, write the first transmit data (first byte) to the TXB6 register. Be sure to check that the TXBF6 flag is “0”. If so, write the next transmit data (second byte) to the TXB6 register. If data is written to the TXB6 register while the TXBF6 flag is “1”, the transmit data cannot be guaranteed.

The communication status can be checked using the TXSF6 flag.

TXSF6	Transmission Status
0	Transmission is completed.
1	Transmission is in progress.

- Cautions**
1. To initialize the transmission unit upon completion of continuous transmission, be sure to check that the TXSF6 flag is “0” after generation of the transmission completion interrupt, and then execute initialization. If initialization is executed while the TXSF6 flag is “1”, the transmit data cannot be guaranteed.
 2. During continuous transmission, the next transmission may complete before execution of INTST6 interrupt servicing after transmission of one data frame. As a countermeasure, detection can be performed by developing a program that can count the number of transmit data and by referencing the TXSF6 flag.

Figure 15-16 shows an example of the continuous transmission processing flow.

Figure 15-16. Example of Continuous Transmission Processing Flow

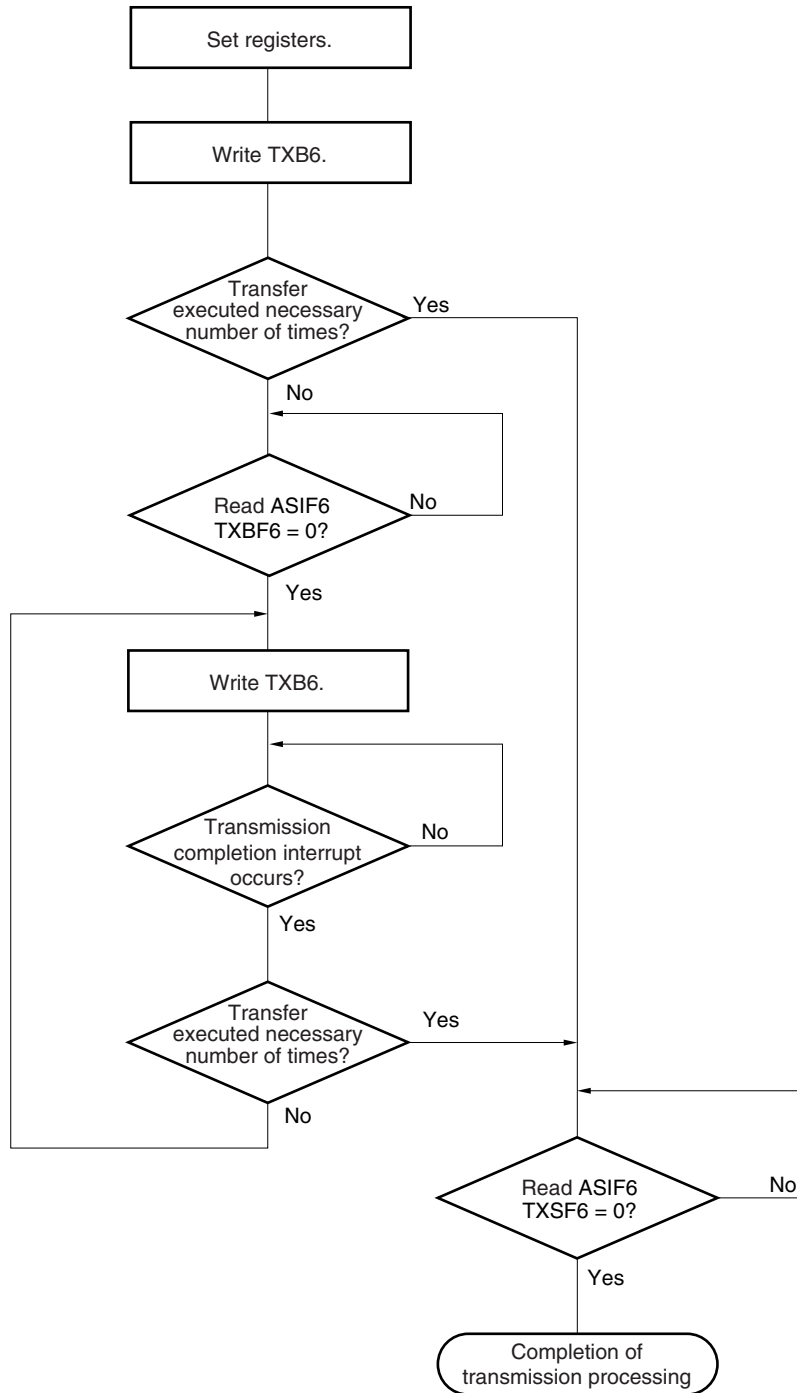

Remark TXB6: Transmit buffer register 6
 ASIF6: Asynchronous serial interface transmission status register 6
 TXBF6: Bit 1 of ASIF6 (transmit buffer data flag)
 TXSF6: Bit 0 of ASIF6 (transmit shift register data flag)

Figure 15-17 shows the timing of starting continuous transmission, and Figure 15-18 shows the timing of ending continuous transmission.

Figure 15-17. Timing of Starting Continuous Transmission

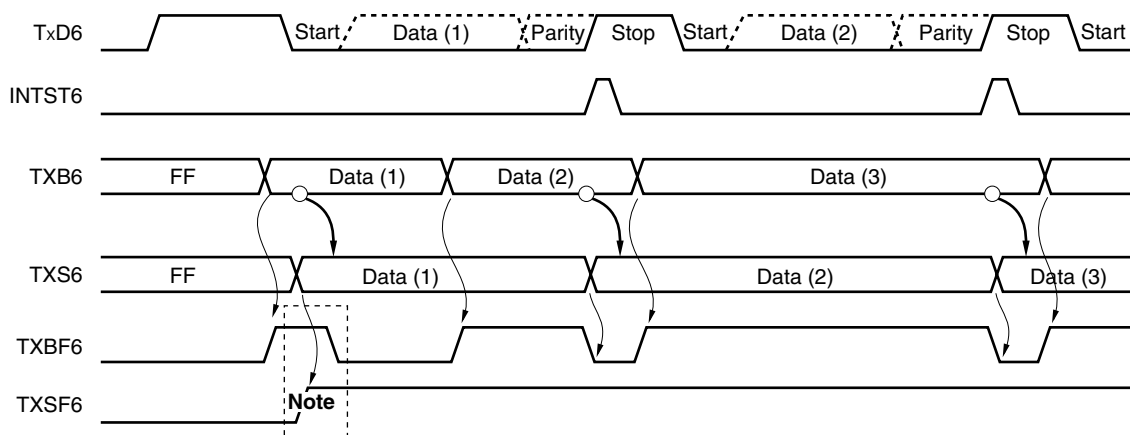

Note When ASIF6 is read, there is a period in which TXBF6 and TXSF6 = 1, 1. Therefore, judge whether writing is enabled using only the TXBF6 bit.

Remark TxD6: TxD6 pin (output)
 INTST6: Interrupt request signal
 TXB6: Transmit buffer register 6
 TXS6: Transmit shift register 6
 ASIF6: Asynchronous serial interface transmission status register 6
 TXBF6: Bit 1 of ASIF6
 TXSF6: Bit 0 of ASIF6

Figure 15-18. Timing of Ending Continuous Transmission

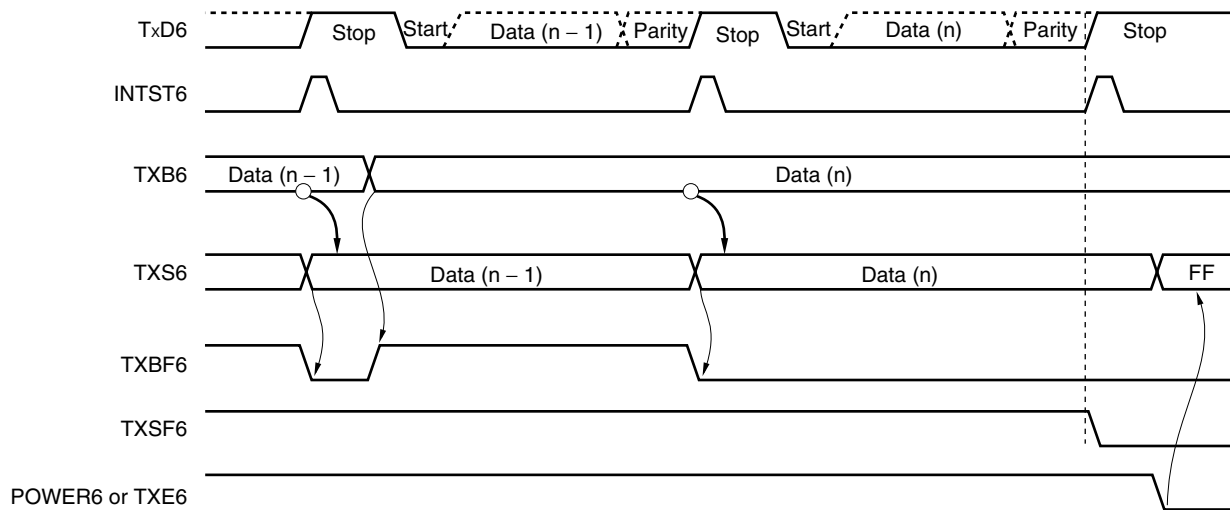

Remark	TxD6:	TxD6 pin (output)
	INTST6:	Interrupt request signal
	TXB6:	Transmit buffer register 6
	TXS6:	Transmit shift register 6
	ASIF6:	Asynchronous serial interface transmission status register 6
	TXBF6:	Bit 1 of ASIF6
	TXSF6:	Bit 0 of ASIF6
	POWER6:	Bit 7 of asynchronous serial interface operation mode register (ASIM6)
	TXE6:	Bit 6 of asynchronous serial interface operation mode register (ASIM6)

(e) Normal reception

Reception is enabled and the RxD6 pin input is sampled when bit 7 (POWER6) of asynchronous serial interface operation mode register 6 (ASIM6) is set to 1 and then bit 5 (RXE6) of ASIM6 is set to 1.

The 8-bit counter of the baud rate generator starts counting when the falling edge of the RxD6 pin input is detected. When the set value of baud rate generator control register 6 (BRGC6) has been counted, the RxD6 pin input is sampled again (▽ in Figure 15-19). If the RxD6 pin is low level at this time, it is recognized as a start bit.

When the start bit is detected, reception is started, and serial data is sequentially stored in the receive shift register (RXS6) at the set baud rate. When the stop bit has been received, the reception completion interrupt (INTSR6) is generated and the data of RXS6 is written to receive buffer register 6 (RXB6). If an overrun error (OVE6) occurs, however, the receive data is not written to RXB6.

Even if a parity error (PE6) occurs while reception is in progress, reception continues to the reception position of the stop bit, and a reception error interrupt (INTSR6/INTSRE6) is generated on completion of reception.

Figure 15-19. Reception Completion Interrupt Request Timing

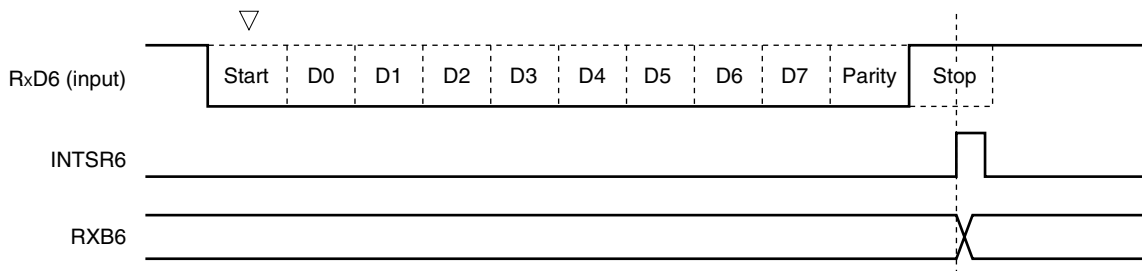

- ★ **Cautions**
1. If a reception error occurs, read ASIS6 and then RXB6 to clear the error flag. Otherwise, an overrun error will occur when the next data is received, and the reception error status will persist.
 2. Reception is always performed with the “number of stop bits = 1”. The second stop bit is ignored.
 3. Be sure to read asynchronous serial interface reception error status register 6 (ASIS6) before reading RXB6.

(f) Reception error

Three types of errors may occur during reception: a parity error, framing error, or overrun error. If the error flag of asynchronous serial interface reception error status register 6 (ASIS6) is set as a result of data reception, a reception error interrupt request (INTSR6/INTSRE6) is generated.

Which error has occurred during reception can be identified by reading the contents of ASIS6 in the reception error interrupt (INTSR6/INTSRE6) servicing (see **Figure 15-6**).

The contents of ASIS6 are cleared to 0 when ASIS6 is read.

Table 15-3. Cause of Reception Error

Reception Error	Cause
Parity error	The parity specified for transmission does not match the parity of the receive data.
Framing error	Stop bit is not detected.
Overrun error	Reception of the next data is completed before data is read from receive buffer register 6 (RXB6).

The reception error interrupt can be separated into reception completion interrupt (INTSR6) and error interrupt (INTSRE6) by clearing bit 0 (ISRM6) of asynchronous serial interface operation mode register 6 (ASIM6) to 0.

Figure 15-20. Reception Error Interrupt

1. If ISRM6 is cleared to 0 (reception completion interrupt (INTSR6) and error interrupt (INTSRE6) are separated)



2. If ISRM6 is set to 1 (error interrupt is included in INTSR6)

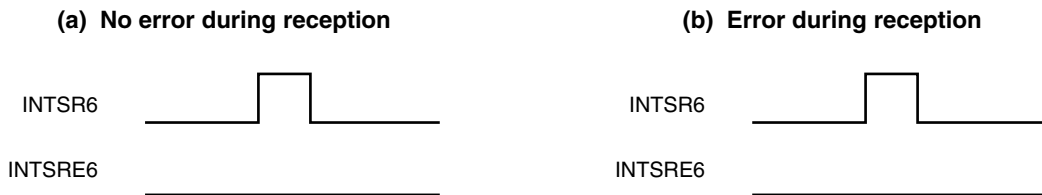

(g) Noise filter of receive data

The RXD6 signal is sampled with the base clock output by the prescaler block.

If two sampled values are the same, the output of the match detector changes, and the data is sampled as input data.

Because the circuit is configured as shown in Figure 15-21, the internal processing of the reception operation is delayed by two clocks from the external signal status.

Figure 15-21. Noise Filter Circuit

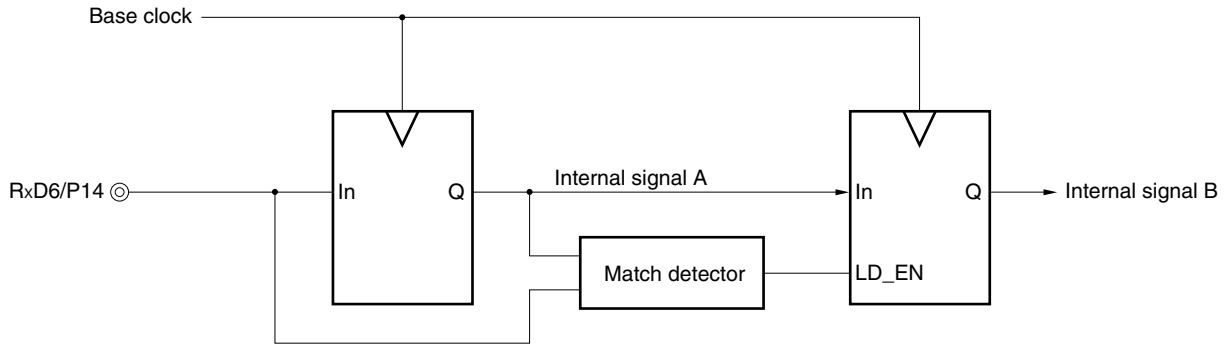

(h) SBF transmission

When the device is incorporated in LIN, the SBF (Synchronous Break Field) transmission control function is used for transmission. For the transmission operation of LIN, see **Figure 15-1 LIN Transmission Operation**.

When bit 7 (POWER6) of asynchronous serial interface mode register 6 (ASIM6) is set to 1, the Tx/D6 pin outputs high level. Next, when bit 6 (TXE6) of ASIM6 is set to 1, the transmission enabled status is entered, and SBF transmission is started by setting bit 5 (SBTT6) of asynchronous serial interface control register 6 (ASICL6) to 1.

Thereafter, a low level of bits 13 to 20 (set by bits 4 to 2 (SBL62 to SBL60) of ASICL6) is output. Following the end of SBF transmission, the transmission completion interrupt request (INTST6) is generated and SBTT6 is automatically cleared.

Thereafter, the normal transmission mode is restored. Transmission is suspended until the data to be transmitted next is written to transmit buffer register 6 (TXB6), or until SBTT6 is set to 1.

Figure 15-22. SBF Transmission

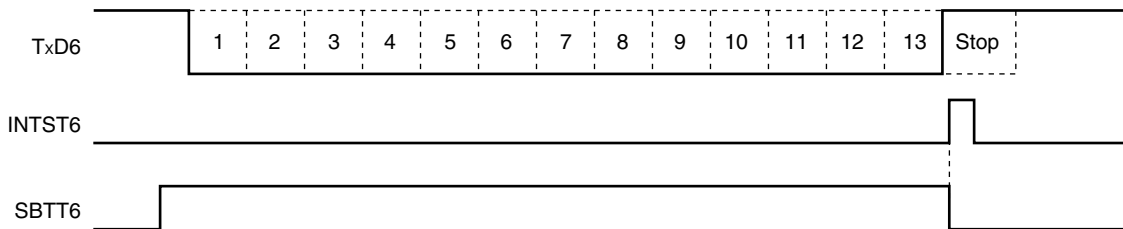

- Remark** Tx/D6: Tx/D6 pin (output)
 INTST6: Transmission completion interrupt request
 SBTT6: Bit 5 of asynchronous serial interface control register 6 (ASICL6)

(i) SBF reception

When the device is incorporated in LIN, the SBF (Synchronous Break Field) reception control function is used for reception. For the reception operation of LIN, see **Figure 15-2 LIN Reception Operation**.

Reception is enabled when bit 7 (POWER6) of asynchronous serial interface operation mode register 6 (ASIM6) is set to 1 and then bit 5 (RXE6) of ASIM6 is set to 1. SBF reception is enabled when bit 6 (SBRT6) of asynchronous serial interface control register 6 (ASICL6) is set to 1. In the SBF reception enabled status, the RxD6 pin is sampled and the start bit is detected in the same manner as the normal reception enable status.

When the start bit has been detected, reception is started, and serial data is sequentially stored in the receive shift register 6 (RXS6) at the set baud rate. When the stop bit is received and if the width of SBF is 11 bits or more, a reception completion interrupt request (INTSR6) is generated as normal processing. At this time, the SBRF6 and SBRT6 bits are automatically cleared, and SBF reception ends. Detection of errors, such as OVE6, PE6, and FE6 (bits 0 to 2 of asynchronous serial interface reception error status register 6 (ASIS6)) is suppressed, and error detection processing of UART communication is not performed. In addition, data transfer between receive shift register 6 (RXS6) and receive buffer register 6 (RXB6) is not performed, and the reset value of FFH is retained. If the width of SBF is 10 bits or less, an interrupt does not occur as error processing after the stop bit has been received, and the SBF reception mode is restored. In this case, the SBRF6 and SBRT6 bits are not cleared.

Figure 15-23. SBF Reception

1. Normal SBF reception (stop bit is detected with a width of more than 10.5 bits)

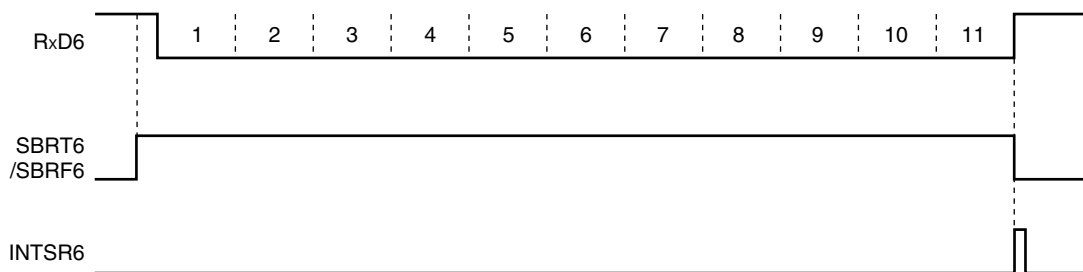

2. SBF reception error (stop bit is detected with a width of 10.5 bits or less)

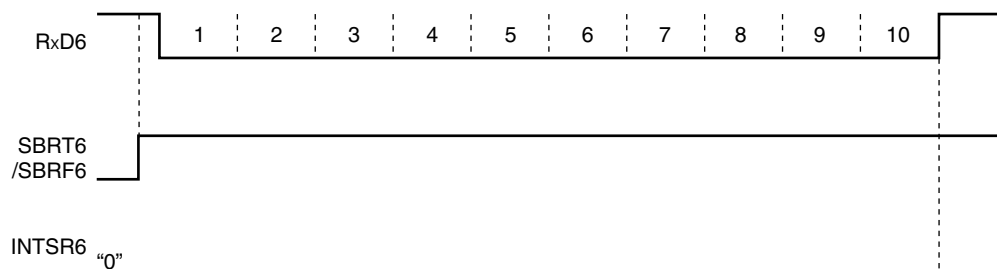

Remark RxD6: RxD6 pin (input)
 SBRT6: Bit 6 of asynchronous serial interface control register 6 (ASICL6)
 SBRF6: Bit 7 of ASICL6
 INTSR6: Reception completion interrupt request

15.4.3 Dedicated baud rate generator

The dedicated baud rate generator consists of a source clock selector and an 8-bit programmable counter, and generates a serial clock for transmission/reception of UART6.

Separate 8-bit counters are provided for transmission and reception.

(1) Configuration of baud rate generator

- Base clock

The clock selected by bits 3 to 0 (TPS63 to TPS60) of clock selection register 6 (CKSR6) is supplied to each module when bit 7 (POWER6) of asynchronous serial interface operation mode register 6 (ASIM6) is 1. This clock is called the base clock and its frequency is called f_{CLK6} . The base clock is fixed to low level when POWER6 = 0.

- Transmission counter

This counter stops operation, cleared to 0, when bit 7 (POWER6) or bit 6 (TXE6) of asynchronous serial interface operation mode register 6 (ASIM6) is 0.

It starts counting when POWER6 = 1 and TXE6 = 1.

The counter is cleared to 0 when the first data transmitted is written to transmit buffer register 6 (TXB6).

If data are continuously transmitted, the counter is cleared to 0 again when one frame of data has been completely transmitted. If there is no data to be transmitted next, the counter is not cleared to 0 and continues counting until POWER6 or TXE6 is cleared to 0.

- Reception counter

This counter stops operation, cleared to 0, when bit 7 (POWER6) or bit 5 (RXE6) of asynchronous serial interface operation mode register 6 (ASIM6) is 0.

It starts counting when the start bit has been detected.

The counter stops operation after one frame has been received, until the next start bit is detected.

Figure 15-24. Configuration of Baud Rate Generator

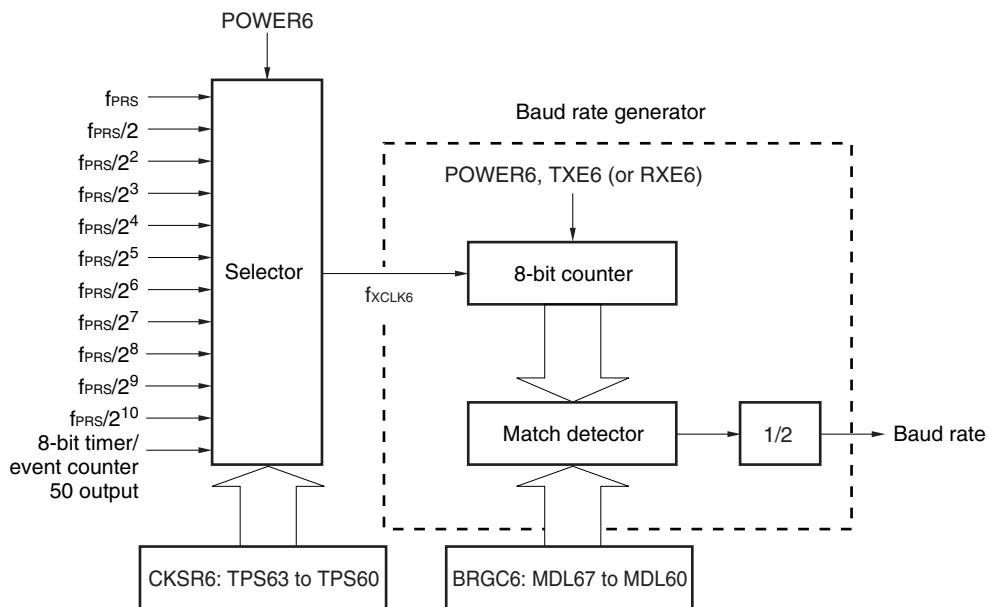

Remark POWER6: Bit 7 of asynchronous serial interface operation mode register 6 (ASIM6)
 TXE6: Bit 6 of ASIM6
 RXE6: Bit 5 of ASIM6
 CKSR6: Clock selection register 6
 BRGC6: Baud rate generator control register 6

(2) Generation of serial clock

A serial clock to be generated can be specified by using clock selection register 6 (CKSR6) and baud rate generator control register 6 (BRGC6).

The clock to be input to the 8-bit counter can be set by bits 3 to 0 (TPS63 to TPS60) of CKSR6 and the division value ($f_{XCLK6}/8$ to $f_{XCLK6}/255$) of the 8-bit counter can be set by bits 7 to 0 (MDL67 to MDL60) of BRGC6.

Table 15-4. Set Value of TPS63 to TPS60

TPS63	TPS62	TPS61	TPS60		Base Clock (f_{XCLK6}) Selection			
					$f_{PRS} = 2 \text{ MHz}$	$f_{PRS} = 5 \text{ MHz}$	$f_{PRS} = 10 \text{ MHz}$	$f_{PRS} = 20 \text{ MHz}$
0	0	0	0	f_{PRS}	2 MHz	5 MHz	10 MHz	20 MHz
0	0	0	1	$f_{PRS}/2$	1 MHz	2.5 MHz	5 MHz	10 MHz
0	0	1	0	$f_{PRS}/2^2$	500 kHz	1.25 MHz	2.5 MHz	5 MHz
0	0	1	1	$f_{PRS}/2^3$	250 kHz	625 kHz	1.25 MHz	2.5 MHz
0	1	0	0	$f_{PRS}/2^4$	125 kHz	312.5 kHz	625 kHz	1.25 MHz
0	1	0	1	$f_{PRS}/2^5$	62.5 kHz	156.25 kHz	312.5 kHz	625 kHz
0	1	1	0	$f_{PRS}/2^6$	31.25 kHz	78.13 kHz	156.25 kHz	312.5 kHz
0	1	1	1	$f_{PRS}/2^7$	15.625 kHz	39.06 kHz	78.13 kHz	156.25 kHz
1	0	0	0	$f_{PRS}/2^8$	7.813 kHz	19.53 kHz	39.06 kHz	78.13 kHz
1	0	0	1	$f_{PRS}/2^9$	3.906 kHz	9.77 kHz	19.53 kHz	39.06 kHz
1	0	1	0	$f_{PRS}/2^{10}$	1.953 kHz	4.88 kHz	9.77 kHz	19.53 kHz
1	0	1	1		TM50 output			
Other than above					Setting prohibited			

(a) Baud rate

The baud rate can be calculated by the following expression.

- Baud rate = $\frac{f_{XCLK6}}{2 \times k}$ [bps]

f_{XCLK6} : Frequency of base clock selected by TPS63 to TPS60 bits of CKSR6 register

k: Value set by MDL67 to MDL60 bits of BRGC6 register (k = 8, 9, 10, ..., 255)

(b) Error of baud rate

The baud rate error can be calculated by the following expression.

- Error (%) = $\left(\frac{\text{Actual baud rate (baud rate with error)}}{\text{Desired baud rate (correct baud rate)}} - 1 \right) \times 100$ [%]

Cautions 1. Keep the baud rate error during transmission to within the permissible error range at the reception destination.

2. Make sure that the baud rate error during reception satisfies the range shown in (4) Permissible baud rate range during reception.

Example: Frequency of base clock = 10 MHz = 10,000,000 Hz

Set value of MDL67 to MDL60 bits of BRGC6 register = 00100001B (k = 33)

Target baud rate = 153600 bps

$$\begin{aligned} \text{Baud rate} &= 10 \text{ M}/(2 \times 33) \\ &= 10000000/(2 \times 33) = 151,515 \text{ [bps]} \end{aligned}$$

$$\begin{aligned} \text{Error} &= (151515/153600 - 1) \times 100 \\ &= -1.357 \text{ [%]} \end{aligned}$$

(3) Example of setting baud rate

Table 15-5. Set Data of Baud Rate Generator

Baud Rate [bps]	f _{PRS} = 2.0 MHz				f _{PRS} = 5.0 MHz				f _{PRS} = 10.0 MHz				f _{PRS} = 20.0 MHz			
	TPS63-TPS60	k	Calculated Value	ERR [%]	TPS63-TPS60	k	Calculated Value	ERR [%]	TPS63-TPS60	k	Calculated Value	ERR [%]	TPS63-TPS60	k	Calculated Value	ERR [%]
300	8H	13	301	0.16	7H	65	301	0.16	8H	65	301	0.16	9H	65	301	0.16
600	7H	13	601	0.16	6H	65	601	0.16	7H	65	601	0.16	8H	65	601	0.16
1200	6H	13	1202	0.16	5H	65	1202	0.16	6H	65	1202	0.16	7H	65	1202	0.16
2400	5H	13	2404	0.16	4H	65	2404	0.16	5H	65	2404	0.16	6H	65	2404	0.16
4800	4H	13	4808	0.16	3H	65	4808	0.16	4H	65	4808	0.16	5H	65	4808	0.16
9600	3H	13	9615	0.16	2H	65	9615	0.16	3H	65	9615	0.16	4H	65	9615	0.16
19200	2H	13	19231	0.16	1H	65	19231	0.16	2H	65	19231	0.16	3H	65	19231	0.16
24000	1H	21	23810	-0.79	3H	13	24038	0.16	4H	13	24038	0.16	5H	13	24038	0.16
31250	1H	4	31250	0	4H	5	31250	0	5H	5	31250	0	6H	5	31250	0
38400	1H	13	38462	0.16	0H	65	38462	0.16	1H	65	38462	0.16	2H	65	38462	0.16
48000	0H	21	47619	-0.79	2H	13	48077	0.16	3H	13	48077	0.16	4H	13	48077	0.16
76800	0H	13	76923	0.16	0H	33	75758	-1.36	0H	65	76923	0.16	1H	65	76923	0.16
115200	0H	9	111111	-3.55	1H	11	113636	-1.36	0H	43	116279	0.94	0H	87	114943	-0.22
153600	-	-	-	-	1H	8	156250	1.73	0H	33	151515	-1.36	1H	33	151515	-1.36
312500	-	-	-	-	0H	8	312500	0	1H	8	312500	0	2H	8	312500	0

Remark TPS63 to TPS60: Bits 3 to 0 of clock selection register 6 (CKSR6) (setting of base clock (f_{CLK6}))
 k: Value set by MDL67 to MDL60 bits of baud rate generator control register 6 (BRGC6) (k = 8, 9, 10, ..., 255)
 f_{PRS}: Peripheral hardware clock frequency
 ERR: Baud rate error

(4) Permissible baud rate range during reception

The permissible error from the baud rate at the transmission destination during reception is shown below.

Caution Make sure that the baud rate error during reception is within the permissible error range, by using the calculation expression shown below.

Figure 15-25. Permissible Baud Rate Range During Reception

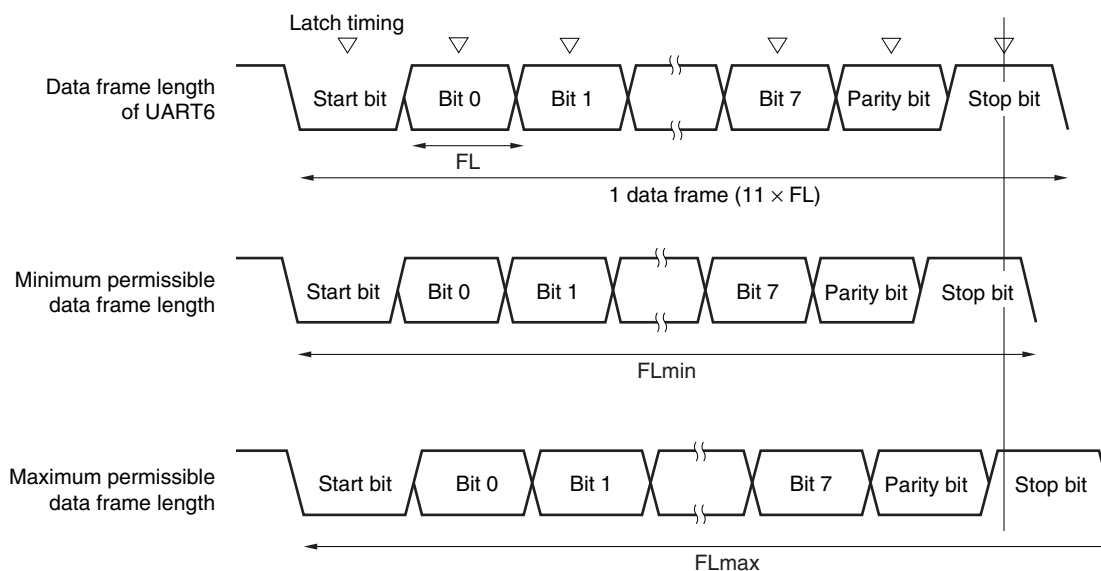

As shown in Figure 15-25, the latch timing of the receive data is determined by the counter set by baud rate generator control register 6 (BRGC6) after the start bit has been detected. If the last data (stop bit) meets this latch timing, the data can be correctly received.

Assuming that 11-bit data is received, the theoretical values can be calculated as follows.

$$FL = (\text{Brate})^{-1}$$

Brate: Baud rate of UART6

k: Set value of BRGC6

FL: 1-bit data length

Margin of latch timing: 2 clocks

$$\text{Minimum permissible data frame length: } FL_{\min} = 11 \times FL - \frac{k-2}{2k} \times FL = \frac{21k+2}{2k} FL$$

Therefore, the maximum receivable baud rate at the transmission destination is as follows.

$$BR_{\max} = (FL_{\min}/11)^{-1} = \frac{22k}{21k+2} \text{ Brate}$$

Similarly, the maximum permissible data frame length can be calculated as follows.

$$\frac{10}{11} \times FL_{\max} = 11 \times FL - \frac{k+2}{2 \times k} \times FL = \frac{21k-2}{2 \times k} FL$$

$$FL_{\max} = \frac{21k-2}{20k} FL \times 11$$

Therefore, the minimum receivable baud rate at the transmission destination is as follows.

$$BR_{\min} = (FL_{\max}/11)^{-1} = \frac{20k}{21k-2} \text{ Brate}$$

The permissible baud rate error between UART6 and the transmission destination can be calculated from the above minimum and maximum baud rate expressions, as follows.

Table 15-6. Maximum/Minimum Permissible Baud Rate Error

Division Ratio (k)	Maximum Permissible Baud Rate Error	Minimum Permissible Baud Rate Error
8	+3.53%	-3.61%
20	+4.26%	-4.31%
50	+4.56%	-4.58%
100	+4.66%	-4.67%
255	+4.72%	-4.73%

Remarks 1. The permissible error of reception depends on the number of bits in one frame, input clock frequency, and division ratio (k). The higher the input clock frequency and the higher the division ratio (k), the higher the permissible error.

2. k: Set value of BRGC6

(5) Data frame length during continuous transmission

When data is continuously transmitted, the data frame length from a stop bit to the next start bit is extended by two clocks of base clock from the normal value. However, the result of communication is not affected because the timing is initialized on the reception side when the start bit is detected.

Figure 15-26. Data Frame Length During Continuous Transmission

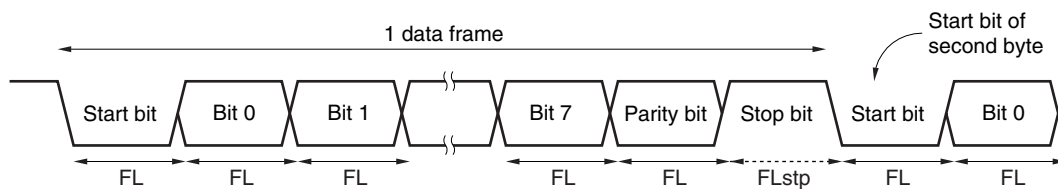

Where the 1-bit data length is FL , the stop bit length is FL_{stp} , and base clock frequency is f_{XCLK6} , the following expression is satisfied.

$$FL_{stp} = FL + 2/f_{XCLK6}$$

Therefore, the data frame length during continuous transmission is:

$$\text{Data frame length} = 11 \times FL + 2/f_{XCLK6}$$

CHAPTER 16 SERIAL INTERFACES CSI10 AND CSI11

The μ PD78F0531, 78F0532, and 78F0533 incorporate serial interface CSI10, and the μ PD78F0534, 78F0535, 78F0536, 78F0537, and 78F0537D incorporate serial interfaces CSI10 and CSI11.

16.1 Functions of Serial Interfaces CSI10 and CSI11

Serial interfaces CSI10 and CSI11 have the following two modes.

- Operation stop mode
- 3-wire serial I/O mode

(1) Operation stop mode

This mode is used when serial communication is not performed and can enable a reduction in the power consumption.

For details, see **16.4.1 Operation stop mode**.

(2) 3-wire serial I/O mode (MSB/LSB-first selectable)

This mode is used to communicate 8-bit data using three lines: a serial clock line ($\overline{\text{SCK1n}}$) and two serial data lines (SI1n and SO1n).

The processing time of data communication can be shortened in the 3-wire serial I/O mode because transmission and reception can be simultaneously executed.

In addition, whether 8-bit data is communicated with the MSB or LSB first can be specified, so this interface can be connected to any device.

The 3-wire serial I/O mode is used for connecting peripheral ICs and display controllers with a clocked serial interface.

For details, see **16.4.2 3-wire serial I/O mode**.

Remark n = 0: μ PD78F0531, 78F0532, 78F0533

n = 0, 1: μ PD78F0534, 78F0535, 78F0536, 78F0537, 78F0537D

(2) Serial I/O shift register 1n (SIO1n)

This is an 8-bit register that converts data from parallel data into serial data and vice versa.

This register can be read by an 8-bit memory manipulation instruction.

Reception is started by reading data from SIO1n if bit 6 (TRMD1n) of serial operation mode register 1n (CSIM1n) is 0.

During reception, the data is read from the serial input pin (SI1n) to SIO1n.

Reset signal generation sets this register to 00H.

Cautions 1. Do not access SIO1n when CSOT1n = 1 (during serial communication).

★ 2. In the slave mode, reception is started when data is read from SIO11 with a low level input to the SSI11 pin. For details on the reception operation, see 16.4.2 (2) Communication operation.

Remark n = 0: μ PD78F0531, 78F0532, 78F0533

n = 0, 1: μ PD78F0534, 78F0535, 78F0536, 78F0537, 78F0537D

16.3 Registers Controlling Serial Interfaces CSI10 and CSI11

Serial interfaces CSI10 and CSI11 are controlled by the following four registers.

- Serial operation mode register 1n (CSIM1n)
- Serial clock selection register 1n (CSIC1n)
- Port mode register 0 (PM0) or port mode register 1 (PM1)
- Port register 0 (P0) or port register 1 (P1)

(1) Serial operation mode register 1n (CSIM1n)

CSIM1n is used to select the operation mode and enable or disable operation.

CSIM1n can be set by a 1-bit or 8-bit memory manipulation instruction.

Reset signal generation sets this register to 00H.

Remark n = 0: μ PD78F0531, 78F0532, 78F0533
 n = 0, 1: μ PD78F0534, 78F0535, 78F0536, 78F0537, 78F0537D

Figure 16-3. Format of Serial Operation Mode Register 10 (CSIM10)

Address: FF80H After reset: 00H R/W^{Note 1}

Symbol	<7>	6	5	4	3	2	1	0
CSIM10	CSIE10	TRMD10	0	DIR10	0	0	0	CSOT10
CSIE10	Operation control in 3-wire serial I/O mode							
0	Disables operation ^{Note 2} and asynchronously resets the internal circuit ^{Note 3} .							
1	Enables operation							
TRMD10 ^{Note 4}	Transmit/receive mode control							
0 ^{Note 5}	Receive mode (transmission disabled).							
1	Transmit/receive mode							
DIR10 ^{Note 6}	First bit specification							
0	MSB							
1	LSB							
CSOT10	Communication status flag							
0	Communication is stopped.							
1	Communication is in progress.							

Notes 1. Bit 0 is a read-only bit.

- ★ 2. To use P10/SCK10/TxD0 and P12/SO10 as general-purpose ports, set CSIM10 in the default status (00H).
- 3. Bit 0 (CSOT10) of CSIM10 and serial I/O shift register 10 (SIO10) are reset.
- 4. Do not rewrite TRMD10 when CSOT10 = 1 (during serial communication).
- 5. The SO10 output (see (a) in **Figure 16-1**) is fixed to the low level when TRMD10 is 0. Reception is started when data is read from SIO10.
- 6. Do not rewrite DIR10 when CSOT10 = 1 (during serial communication).

Caution Be sure to clear bit 5 to 0.

Figure 16-4. Format of Serial Operation Mode Register 11 (CSIM11)

Address: FF88H After reset: 00H R/W^{Note 1}

Symbol	<7>	6	5	4	3	2	1	0
CSIM11	CSIE11	TRMD11	SSE11	DIR11	0	0	0	CSOT11

CSIE11	Operation control in 3-wire serial I/O mode
0	Disables operation ^{Note 2} and asynchronously resets the internal circuit ^{Note 3} .
1	Enables operation

TRMD11 ^{Note 4}	Transmit/receive mode control
0 ^{Note 5}	Receive mode (transmission disabled).
1	Transmit/receive mode

SSE11 ^{Notes 6, 7}	$\overline{\text{SSI11}}$ pin use selection
0	$\overline{\text{SSI11}}$ pin is not used
1	$\overline{\text{SSI11}}$ pin is used

DIR11 ^{Note 8}	First bit specification
0	MSB
1	LSB

CSOT11	Communication status flag
0	Communication is stopped.
1	Communication is in progress.

- Notes**
1. Bit 0 is a read-only bit.
 2. To use P02/SO11, P04/ $\overline{\text{SCK11}}$, and P05/ $\overline{\text{SSI11}}$ /TI001 as general-purpose ports, set CSIM11 in the default status (00H).
 3. Bit 0 (CSOT11) of CSIM11 and serial I/O shift register 11 (SIO11) are reset.
 4. Do not rewrite TRMD11 when CSOT11 = 1 (during serial communication).
 5. The SO11 output (see (a) in **Figure 16-2**) is fixed to the low level when TRMD11 is 0. Reception is started when data is read from SIO11.
 6. Do not rewrite SSE11 when CSOT11 = 1 (during serial communication).
 7. Before setting this bit to 1, fix the $\overline{\text{SSI11}}$ pin input level to 0 or 1.
 8. Do not rewrite DIR11 when CSOT11 = 1 (during serial communication).

★

(2) Serial clock selection register 1n (CSIC1n)

This register specifies the timing of the data transmission/reception and sets the serial clock. CSIC1n can be set by a 1-bit or 8-bit memory manipulation instruction. Reset signal generation sets this register to 00H.

Remark n = 0: μ PD78F0531, 78F0532, 78F0533
 n = 0, 1: μ PD78F0534, 78F0535, 78F0536, 78F0537, 78F0537D

Figure 16-5. Format of Serial Clock Selection Register 10 (CSIC10)

Address: FF81H After reset: 00H R/W

Symbol	7	6	5	4	3	2	1	0
CSIC10	0	0	0	CKP10	DAP10	CKS102	CKS101	CKS100

CKP10	DAP10	Specification of data transmission/reception timing	Type
0	0		1
0	1		2
1	0		3
1	1		4

CKS102	CKS101	CKS100	CSI10 serial clock selection				Mode	
			f _{PRS} = 2 MHz	f _{PRS} = 5 MHz	f _{PRS} = 10 MHz	f _{PRS} = 20 MHz		
0	0	0	f _{PRS} /2	1 MHz	2.5 MHz	5 MHz	10 MHz	Master mode
0	0	1	f _{PRS} /2 ²	500 kHz	1.25 MHz	2.5 MHz	5 MHz	
0	1	0	f _{PRS} /2 ³	250 kHz	625 kHz	1.25 MHz	2.5 MHz	
0	1	1	f _{PRS} /2 ⁴	125 kHz	312.5 kHz	625 kHz	1.25 MHz	
1	0	0	f _{PRS} /2 ⁵	62.5 kHz	156.25 kHz	312.5 kHz	625 kHz	
1	0	1	f _{PRS} /2 ⁶	31.25 kHz	78.13 kHz	156.25 kHz	312.5 kHz	
1	1	0	f _{PRS} /2 ⁷	15.63 kHz	39.06 kHz	78.13 kHz	156.25 kHz	
1	1	1	External clock input to $\overline{SCK10}$				Slave mode	

Cautions 1. Do not write to CSIC10 while CSIE10 = 1 (operation enabled).

★ 2. To use P10/ $\overline{SCK10}$ /TxD0 and P12/SO10 as general-purpose ports, set CSIC10 in the default status (00H).

3. The phase type of the data clock is type 1 after reset.

Remark f_{PRS}: Peripheral hardware clock frequency

Figure 16-6. Format of Serial Clock Selection Register 11 (CSIC11)

Address: FF89H After reset: 00H R/W

Symbol	7	6	5	4	3	2	1	0
CSIC11	0	0	0	CKP11	DAP11	CKS112	CKS111	CKS110

CKP11	DAP11	Specification of data transmission/reception timing	Type
0	0		1
0	1		2
1	0		3
1	1		4

CKS112	CKS111	CKS110	CSI11 serial clock selection				Mode	
			$f_{PRS} = 2 \text{ MHz}$	$f_{PRS} = 5 \text{ MHz}$	$f_{PRS} = 10 \text{ MHz}$	$f_{PRS} = 20 \text{ MHz}$		
0	0	0	$f_{PRS}/2$	1 MHz	2.5 MHz	5 MHz	10 MHz	Master mode
0	0	1	$f_{PRS}/2^2$	500 kHz	1.25 MHz	2.5 MHz	5 MHz	
0	1	0	$f_{PRS}/2^3$	250 kHz	625 kHz	1.25 MHz	2.5 MHz	
0	1	1	$f_{PRS}/2^4$	125 kHz	312.5 kHz	625 kHz	1.25 MHz	
1	0	0	$f_{PRS}/2^5$	62.5 kHz	156.25 kHz	312.5 kHz	625 kHz	
1	0	1	$f_{PRS}/2^6$	31.25 kHz	78.13 kHz	156.25 kHz	312.5 kHz	
1	1	0	$f_{PRS}/2^7$	15.63 kHz	39.06 kHz	78.13 kHz	156.25 kHz	
1	1	1	External clock input to $\overline{\text{SCK11}}$				Slave mode	

- ★ **Cautions**
1. Do not write to CSIC11 while CSIE11 = 1 (operation enabled).
 2. To use P02/SO11 and P04/ $\overline{\text{SCK11}}$ as general-purpose ports, set CSIC11 in the default status (00H).
 3. The phase type of the data clock is type 1 after reset.

Remark f_{PRS} : Peripheral hardware clock frequency

(3) Port mode registers 0 and 1 (PM0, PM1)

These registers set port 0 and 1 input/output in 1-bit units.

When using P10/ $\overline{\text{SCK10}}$ and P04/ $\overline{\text{SCK11}}$ ^{Note} as the clock output pins of the serial interface, clear PM10 and PM04 to 0, and set the output latches of P10 and P04 to 1.

When using P12/SO10 and P02/SO11^{Note} as the data output pins of the serial interface, clear PM12, PM02, and the output latches of P12 and P02 to 0.

When using P10/ $\overline{\text{SCK10}}$ and P04/ $\overline{\text{SCK11}}$ ^{Note} as the clock input pins of the serial interface, P11/SI10/RxD0 and P03/SI11^{Note} as the data input pins, and P05/ $\overline{\text{SSI11}}$ ^{Note}/TI001 as the chip select input pin, set PM10, PM04, PM11, PM03, and PM05 to 1. At this time, the output latches of P10, P04, P11, P03, and P05 may be 0 or 1.

PM0 and PM1 can be set by a 1-bit or 8-bit memory manipulation instruction.

Reset signal generation sets these registers to FFH.

Note Available only in the μ PD78F0534, 78F0535, 78F0536, 78F0537, 78F0537D

Figure 16-7. Format of Port Mode Register 0 (PM0)

Address: FF20H After reset: FFH R/W

Symbol	7	6	5	4	3	2	1	0
PM0	1	PM06	PM05	PM04	PM03	PM02	PM01	PM00

PM0n	P0n pin I/O mode selection (n = 0 to 6)
0	Output mode (output buffer on)
1	Input mode (output buffer off)

Figure 16-8. Format of Port Mode Register 1 (PM1)

Address: FF21H After reset: FFH R/W

Symbol	7	6	5	4	3	2	1	0
PM1	PM17	PM16	PM15	PM14	PM13	PM12	PM11	PM10

PM1n	P1n pin I/O mode selection (n = 0 to 7)
0	Output mode (output buffer on)
1	Input mode (output buffer off)

16.4 Operation of Serial Interfaces CSI10 and CSI11

Serial interfaces CSI10 and CSI11 can be used in the following two modes.

- Operation stop mode
- 3-wire serial I/O mode

16.4.1 Operation stop mode

Serial communication is not executed in this mode. Therefore, the power consumption can be reduced. In addition, the P10/ $\overline{\text{SCK10}}$ /TxD0, P11/SI10/RxD0, P12/SO10, P02/SO11^{Note}, P03/SI11^{Note}, and P04/ $\overline{\text{SCK11}}$ ^{Note} pins can be used as ordinary I/O port pins in this mode.

Note Available only in the μ PD78F0534, 78F0535, 78F0536, 78F0537, 78F0537D

(1) Register used

The operation stop mode is set by serial operation mode register 1n (CSIM1n).

To set the operation stop mode, clear bit 7 (CSIE1n) of CSIM1n to 0.

(a) Serial operation mode register 1n (CSIM1n)

CSIM1n can be set by a 1-bit or 8-bit memory manipulation instruction.

Reset signal generation sets CSIM1n to 00H.

Remark n = 0: μ PD78F0531, 78F0532, 78F0533
 n = 0, 1: μ PD78F0534, 78F0535, 78F0536, 78F0537, 78F0537D

- Serial operation mode register 10 (CSIM10)

Address: FF80H After reset: 00H R/W

Symbol	<7>	6	5	4	3	2	1	0
CSIM10	CSIE10	TRMD10	0	DIR10	0	0	0	CSOT10
	CSIE10	Operation control in 3-wire serial I/O mode						
	0	Disables operation ^{Note 1} and asynchronously resets the internal circuit ^{Note 2} .						

- ★ **Notes 1.** To use P10/ $\overline{\text{SCK10}}$ /TxD0 and P12/SO10 as general-purpose ports, set CSIM10 in the default status (00H).
- 2.** Bit 0 (CSOT10) of CSIM10 and serial I/O shift register 10 (SIO10) are reset.

- Serial operation mode register 11 (CSIM11)

Address: FF88H After reset: 00H R/W

Symbol	<7>	6	5	4	3	2	1	0
CSIM11	CSIE11	TRMD11	SSE11	DIR11	0	0	0	CSOT11
	CSIE11	Operation control in 3-wire serial I/O mode						
	0	Disables operation ^{Note 1} and asynchronously resets the internal circuit ^{Note 2} .						

- ★ **Notes 1.** To use P02/SO11, P04/ $\overline{\text{SCK11}}$, and P05/ $\overline{\text{SSI11}}$ /TI001 as general-purpose ports, set CSIM11 in the default status (00H).
- 2.** Bit 0 (CSOT11) of CSIM11 and serial I/O shift register 11 (SIO11) are reset.

16.4.2 3-wire serial I/O mode

The 3-wire serial I/O mode is used for connecting peripheral ICs and display controllers with a clocked serial interface.

In this mode, communication is executed by using three lines: the serial clock ($\overline{\text{SCK1n}}$), serial output (SO1n), and serial input (SI1n) lines.

(1) Registers used

- Serial operation mode register 1n (CSIM1n)
- Serial clock selection register 1n (CSIC1n)
- Port mode register 0 (PM0) or port mode register 1 (PM1)
- Port register 0 (P0) or port register 1 (P1)

The basic procedure of setting an operation in the 3-wire serial I/O mode is as follows.

- <1> Set the CSIC1n register (see **Figures 16-5** and **16-6**).
- <2> Set bits 0 and 4 to 6 (CSOT1n, DIR1n, SSE11 (serial interface CSI11 only), and TRMD1n) of the CSIM1n register (see **Figures 16-3** and **16-4**).
- <3> Set bit 7 (CSIE1n) of the CSIM1n register to 1. → Transmission/reception is enabled.
- <4> Write data to transmit buffer register 1n (SOTB1n). → Data transmission/reception is started.
Read data from serial I/O shift register 1n (SIO1n). → Data reception is started.

Caution Take relationship with the other party of communication when setting the port mode register and port register.

Remark n = 0: μ PD78F0531, 78F0532, 78F0533
n = 0, 1: μ PD78F0534, 78F0535, 78F0536, 78F0537, 78F0537D

The relationship between the register settings and pins is shown below.

Table 16-2. Relationship Between Register Settings and Pins (1/2)

(a) Serial interface CSI10

CSIE10	TRMD10	PM11	P11	PM12	P12	PM10	P10	CSI10 Operation	Pin Function		
									SI10/RxD0/P11	SO10/P12	$\overline{\text{SCK10}}$ /TxD0/P10
0	x	× ^{Note 1}	× ^{Note 1}	× ^{Note 1}	× ^{Note 1}	× ^{Note 1}	× ^{Note 1}	Stop	RxD0/P11	P12	TxD0/P10 ^{Note 2}
1	0	1	×	× ^{Note 1}	× ^{Note 1}	1	×	Slave reception ^{Note 3}	SI10	P12	$\overline{\text{SCK10}}$ (input) ^{Note 3}
1	1	× ^{Note 1}	× ^{Note 1}	0	0	1	×	Slave transmission ^{Note 3}	RxD0/P11	SO10	$\overline{\text{SCK10}}$ (input) ^{Note 3}
1	1	1	×	0	0	1	×	Slave transmission/reception ^{Note 3}	SI10	SO10	$\overline{\text{SCK10}}$ (input) ^{Note 3}
1	0	1	×	× ^{Note 1}	× ^{Note 1}	0	1	Master reception	SI10	P12	$\overline{\text{SCK10}}$ (output)
1	1	× ^{Note 1}	× ^{Note 1}	0	0	0	1	Master transmission	RxD0/P11	SO10	$\overline{\text{SCK10}}$ (output)
1	1	1	×	0	0	0	1	Master transmission/reception	SI10	SO10	$\overline{\text{SCK10}}$ (output)

- Notes**
1. Can be set as port function.
 2. To use P10/ $\overline{\text{SCK10}}$ /TxD0 as port pins, clear CKP10 to 0.
 3. To use the slave mode, set CKS102, CKS101, and CKS100 to 1, 1, 1.

Remark

×: don't care

CSIE10: Bit 7 of serial operation mode register 10 (CSIM10)

TRMD10: Bit 6 of CSIM10

CKP10: Bit 4 of serial clock selection register 10 (CSIC10)

CKS102, CKS101, CKS100: Bits 2 to 0 of CSIC10

PM1×: Port mode register

P1×: Port output latch

Table 16-2. Relationship Between Register Settings and Pins (2/2)

(b) Serial interface CSI11 (Available only in the μ PD78F0534, 78F0535, 78F0536, 78F0537, 78F0537D)

CSIE11	TRMD11	SSE11	PM03	P03	PM02	P02	PM04	P04	PM05	P05	CSI11 Operation	Pin Function			
												SI11/ P03	SO11/ P02	SCK11/ P04	SSI11/ TI001/P05
0	×	×	×	×	×	×	×	×	Stop	P03	P02	P04 ^{Note 2}	TI001/ P05		
1	0	0	1	×	×	×	1	×	×	×	Slave reception ^{Note 3}	SI11	P02	SCK11 (input) ^{Note 3}	TI001/ P05
		1					1	×	SSI11						
1	1	0	×	×	0	0	1	×	×	×	Slave transmission ^{Note 3}	P03	SO11	SCK11 (input) ^{Note 3}	TI001/ P05
		1					1	×	SSI11						
1	1	0	1	×	0	0	1	×	×	×	Slave transmission/ reception ^{Note 3}	SI11	SO11	SCK11 (input) ^{Note 3}	TI001/ P05
		1					1	×	SSI11						
1	0	0	1	×	×	×	0	1	×	×	Master reception	SI11	P02	SCK11 (output)	TI001/ P05
1	1	0	×	×	0	0	0	1	×	×	Master transmission	P03	SO11	SCK11 (output)	TI001/ P05
1	1	0	1	×	0	0	0	1	×	×	Master transmission/ reception	SI11	SO11	SCK11 (output)	TI001/ P05

- Notes**
1. Can be set as port function.
 2. To use P04/SCK11 as port pins, clear CKP11 to 0.
 3. To use the slave mode, set CKS112, CKS111, and CKS110 to 1, 1, 1.

Remark

- ×: don't care
- CSIE11: Bit 7 of serial operation mode register 11 (CSIM11)
- TRMD11: Bit 6 of CSIM11
- CKP11: Bit 4 of serial clock selection register 11 (CSIC11)
- CKS112, CKS111, CKS110: Bits 2 to 0 of CSIC11
- PM0x: Port mode register
- P0x: Port output latch

(2) Communication operation

In the 3-wire serial I/O mode, data is transmitted or received in 8-bit units. Each bit of the data is transmitted or received in synchronization with the serial clock.

Data can be transmitted or received if bit 6 (TRMD1n) of serial operation mode register 1n (CSIM1n) is 1. Transmission/reception is started when a value is written to transmit buffer register 1n (SOTB1n). In addition, data can be received when bit 6 (TRMD1n) of serial operation mode register 1n (CSIM1n) is 0.

Reception is started when data is read from serial I/O shift register 1n (SIO1n).

However, communication is performed as follows if bit 5 (SSE11) of CSIM11 is 1 when serial interface CSI11 is in the slave mode.

- <1> Low level input to the $\overline{\text{SSI11}}$ pin
→ Transmission/reception is started when SOTB11 is written, or reception is started when SIO11 is read.
- <2> High level input to the $\overline{\text{SSI11}}$ pin
→ Transmission/reception or reception is held, therefore, even if SOTB11 is written or SIO11 is read, transmission/reception or reception will not be started.
- <3> Data is written to SOTB11 or data is read from SIO11 while a high level is input to the $\overline{\text{SSI11}}$ pin, then a low level is input to the $\overline{\text{SSI11}}$ pin
→ Transmission/reception or reception is started.
- <4> A high level is input to the $\overline{\text{SSI11}}$ pin during transmission/reception or reception
→ Transmission/reception or reception is suspended.

After communication has been started, bit 0 (CSOT1n) of CSIM1n is set to 1. When communication of 8-bit data has been completed, a communication completion interrupt request flag (CSIIF1n) is set, and CSOT1n is cleared to 0. Then the next communication is enabled.

- Cautions**
1. Do not access the control register and data register when CSOT1n = 1 (during serial communication).
 2. When using serial interface CSI11, wait for the duration of at least one clock before the clock operation is started to change the level of the $\overline{\text{SSI11}}$ pin in the slave mode; otherwise, malfunctioning may occur.

Remark n = 0: μ PD78F0531, 78F0532, 78F0533
n = 0, 1: μ PD78F0534, 78F0535, 78F0536, 78F0537, 78F0537D

Figure 16-9. Timing in 3-Wire Serial I/O Mode (1/2)

(a) Transmission/reception timing (Type 1: TRMD1n = 1, DIR1n = 0, CKP1n = 0, DAP1n = 0, SSE11 = 1^{Note})

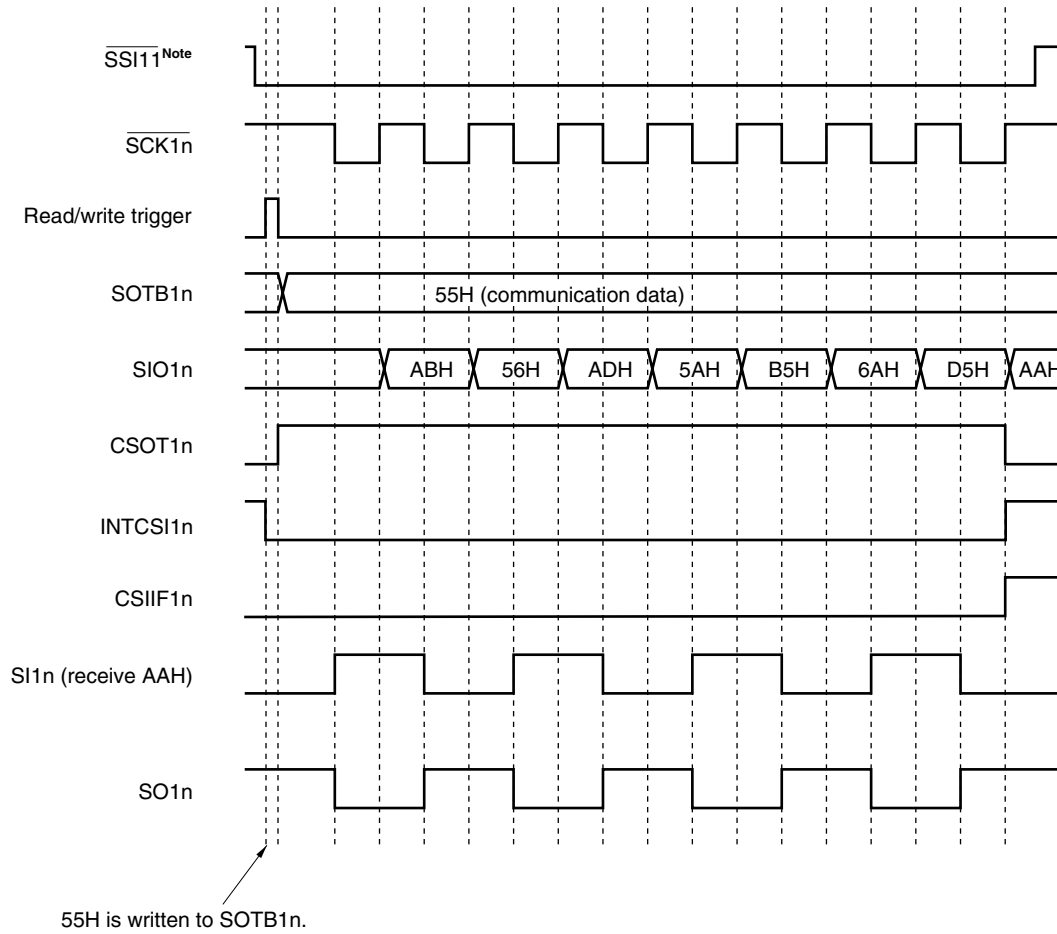

Note The SSE11 flag and $\overline{\text{SSI11}}$ pin are available only for serial interface CSI11, and are used in the slave mode.

Remark n = 0: $\mu\text{PD78F0531}$, 78F0532, 78F0533
 n = 0, 1: $\mu\text{PD78F0534}$, 78F0535, 78F0536, 78F0537, 78F0537D

Figure 16-9. Timing in 3-Wire Serial I/O Mode (2/2)

(b) Transmission/reception timing (Type 2: TRMD1n = 1, DIR1n = 0, CKP1n = 0, DAP1n = 1, SSE11 = 1^{Note})

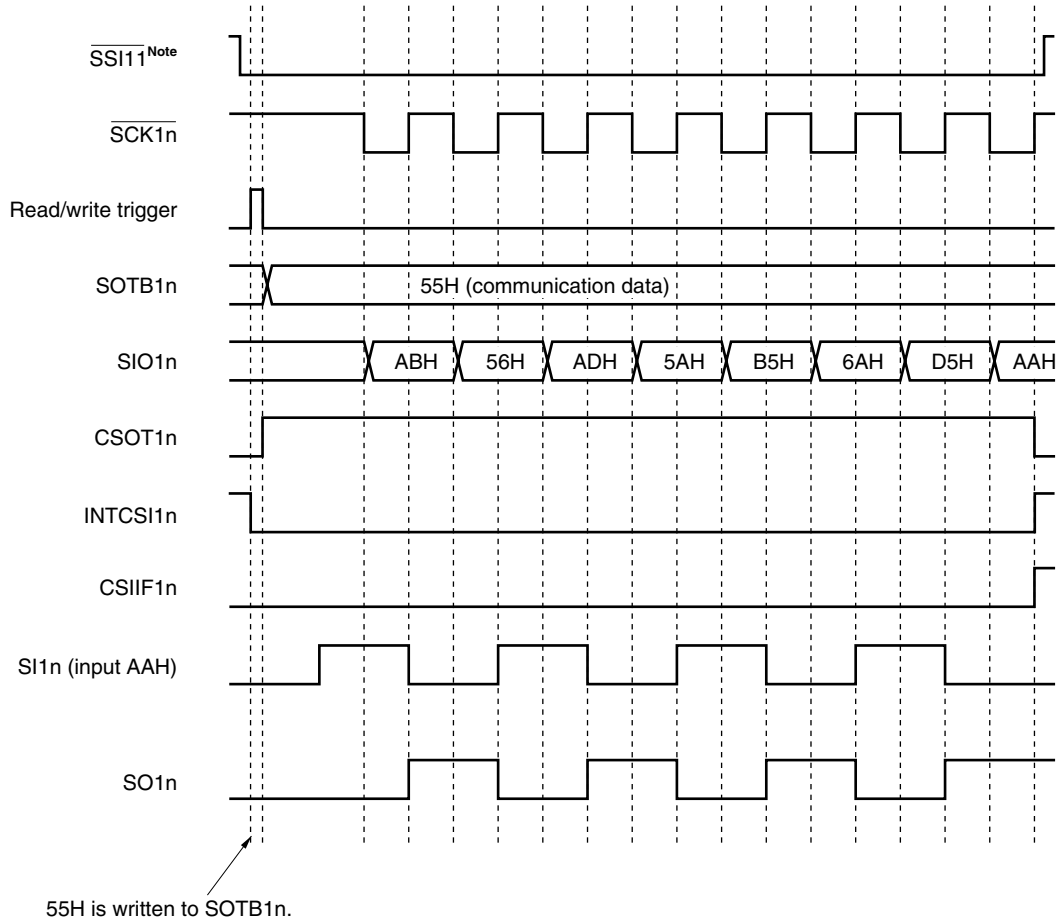

Note The SSE11 flag and $\overline{\text{SSI11}}$ pin are available only for serial interface CSI11, and are used in the slave mode.

Remark n = 0: $\mu\text{PD78F0531, 78F0532, 78F0533}$
 n = 0, 1: $\mu\text{PD78F0534, 78F0535, 78F0536, 78F0537, 78F0537D}$

Figure 16-10. Timing of Clock/Data Phase

(a) Type 1: CKP1n = 0, DAP1n = 0, DIR1n = 0

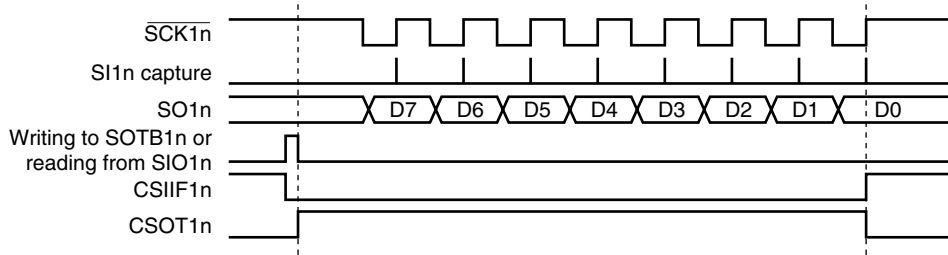

(b) Type 2: CKP1n = 0, DAP1n = 1, DIR1n = 0

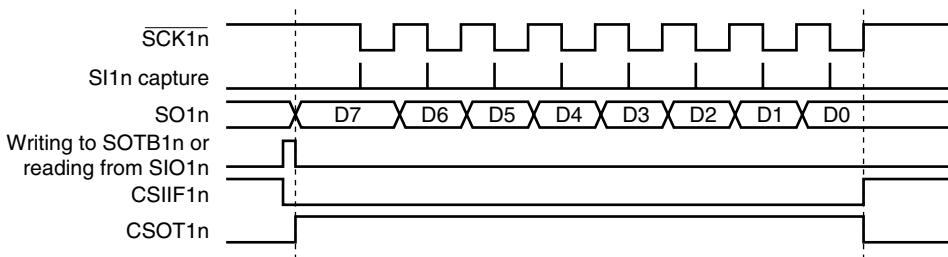

(c) Type 3: CKP1n = 1, DAP1n = 0, DIR1n = 0

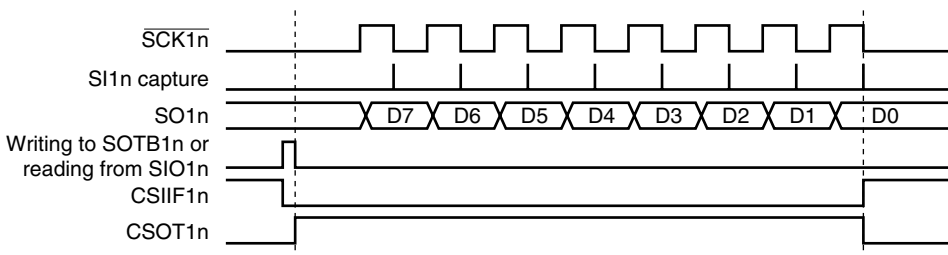

(d) Type 4: CKP1n = 1, DAP1n = 1, DIR1n = 0

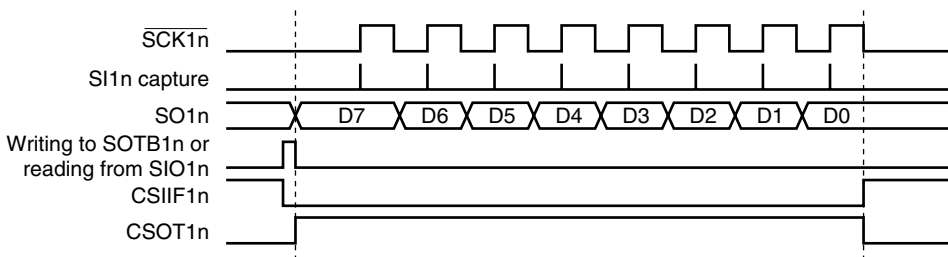

Remarks 1. n = 0: μ PD78F0531, 78F0532, 78F0533

n = 0, 1: μ PD78F0534, 78F0535, 78F0536, 78F0537, 78F0537D

2. The above figure illustrates a communication operation where data is transmitted with the MSB first.

(3) Timing of output to SO1n pin (first bit)

When communication is started, the value of transmit buffer register 1n (SOTB1n) is output from the SO1n pin. The output operation of the first bit at this time is described below.

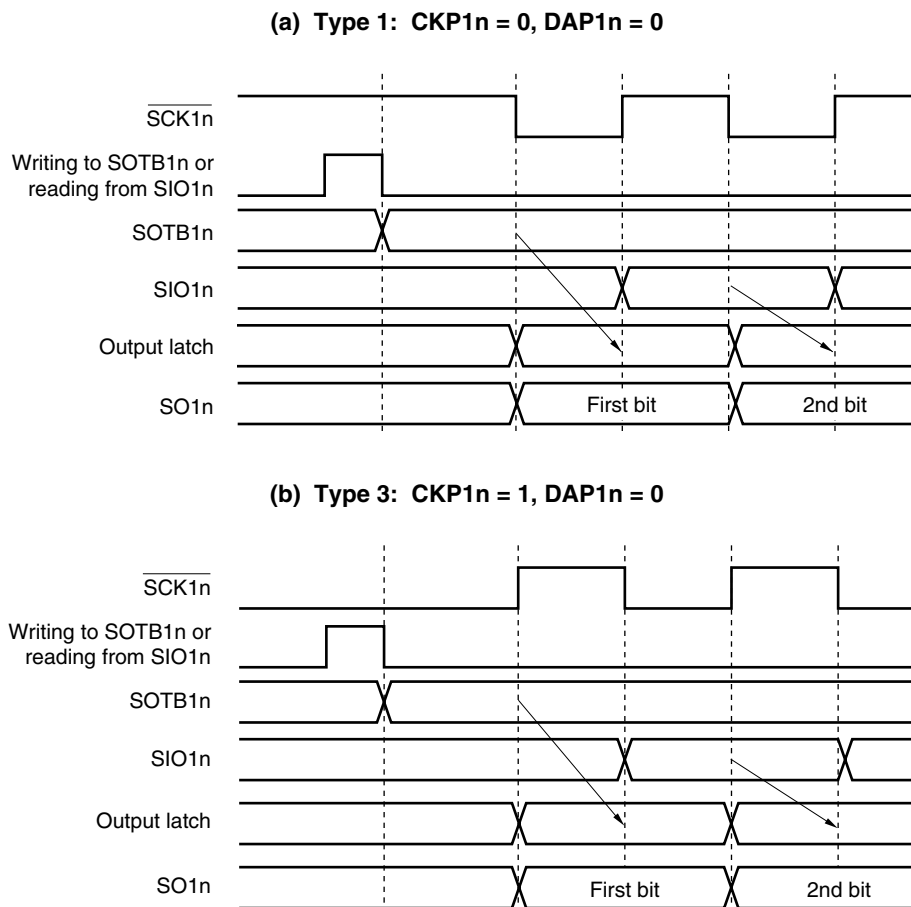
Figure 16-11. Output Operation of First Bit (1/2)

The first bit is directly latched by the SOTB1n register to the output latch at the falling (or rising) edge of $\overline{SCK1n}$, and output from the SO1n pin via an output selector. Then, the value of the SOTB1n register is transferred to the SIO1n register at the next rising (or falling) edge of $\overline{SCK1n}$, and shifted one bit. At the same time, the first bit of the receive data is stored in the SIO1n register via the SI1n pin.

The second and subsequent bits are latched by the SIO1n register to the output latch at the next falling (or rising) edge of $\overline{SCK1n}$, and the data is output from the SO1n pin.

Remark n = 0: μ PD78F0531, 78F0532, 78F0533
 n = 0, 1: μ PD78F0534, 78F0535, 78F0536, 78F0537, 78F0537D

Figure 16-11. Output Operation of First Bit (2/2)

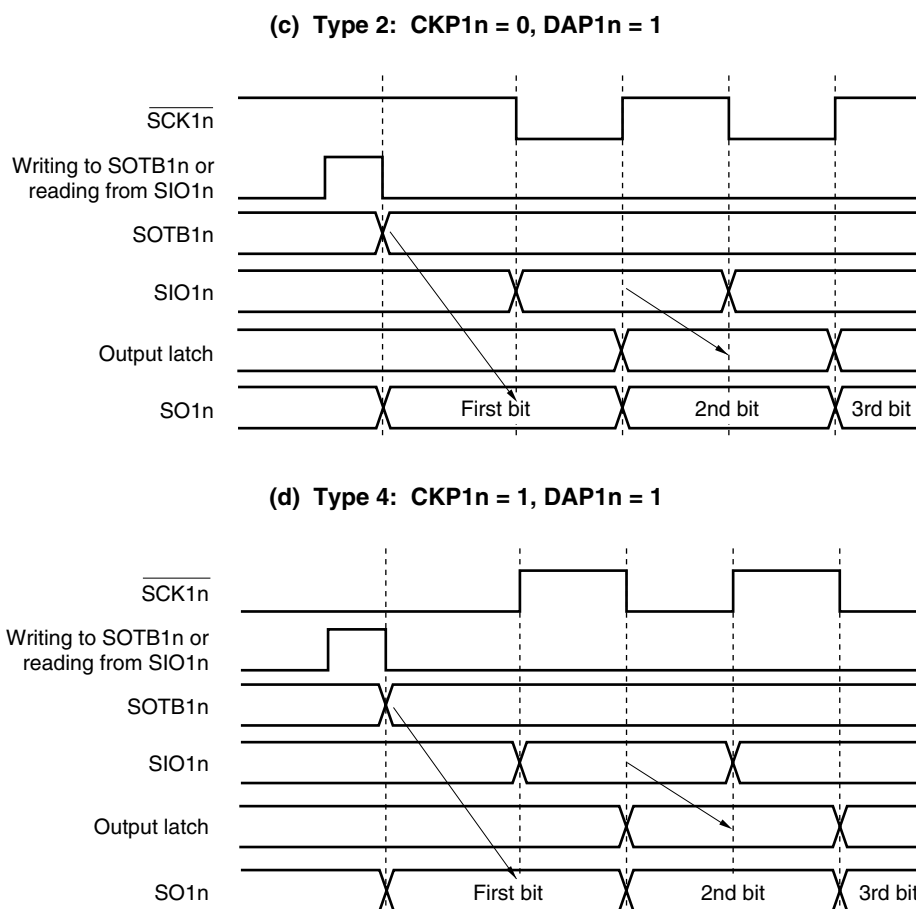

The first bit is directly latched by the SOTB1n register at the falling edge of the write signal of the SOTB1n register or the read signal of the SIO1n register, and output from the SO1n pin via an output selector. Then, the value of the SOTB1n register is transferred to the SIO1n register at the next falling (or rising) edge of $\overline{SCK1n}$, and shifted one bit. At the same time, the first bit of the receive data is stored in the SIO1n register via the SI1n pin. The second and subsequent bits are latched by the SIO1n register to the output latch at the next rising (or falling) edge of $\overline{SCK1n}$, and the data is output from the SO1n pin.

Remark n = 0: μ PD78F0531, 78F0532, 78F0533
 n = 0, 1: μ PD78F0534, 78F0535, 78F0536, 78F0537, 78F0537D

(4) Output value of SO1n pin (last bit)

After communication has been completed, the SO1n pin holds the output value of the last bit.

Figure 16-12. Output Value of SO1n Pin (Last Bit) (1/2)

(a) Type 1: CKP1n = 0, DAP1n = 0

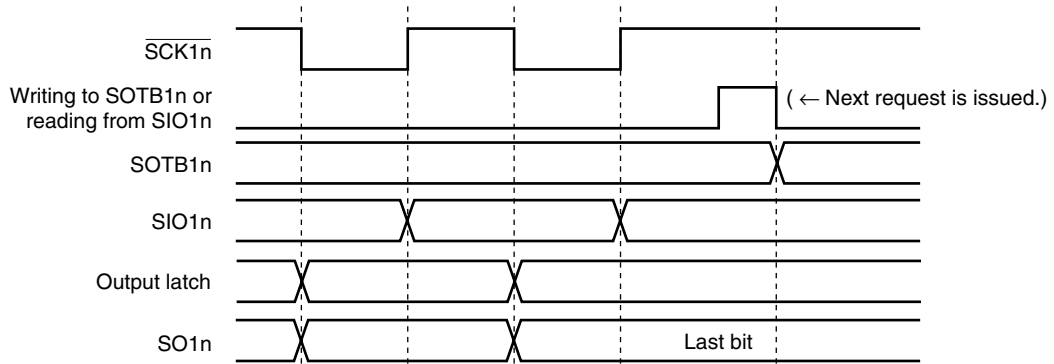

★

(b) Type 3: CKP1n = 1, DAP1n = 0

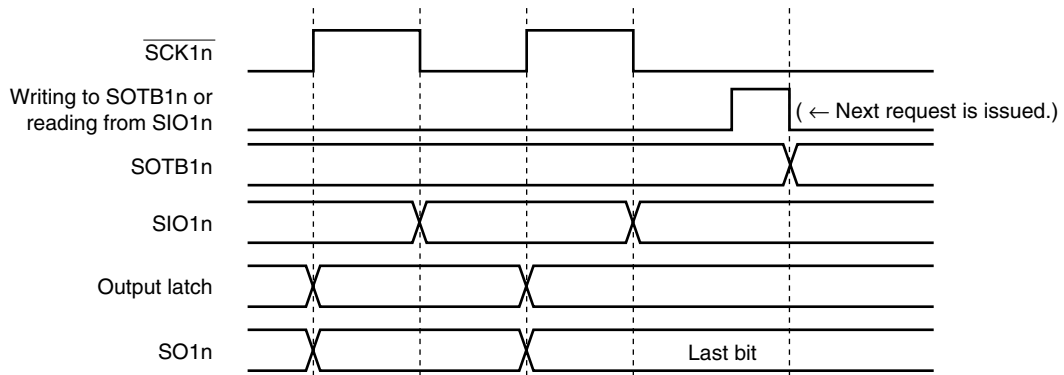

Remark n = 0: μ PD78F0531, 78F0532, 78F0533
 n = 0, 1: μ PD78F0534, 78F0535, 78F0536, 78F0537, 78F0537D

Figure 16-12. Output Value of SO1n Pin (Last Bit) (2/2)

(c) Type 2: CKP1n = 0, DAP1n = 1

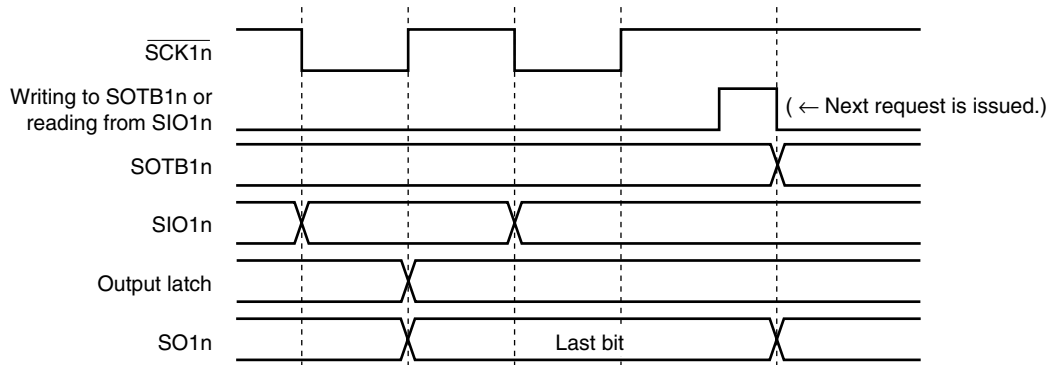

★

(d) Type 4: CKP1n = 1, DAP1n = 1

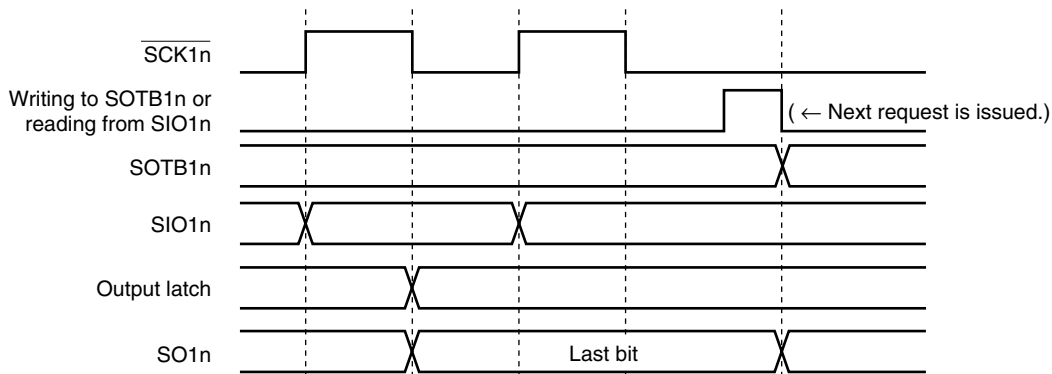

Remark n = 0: μ PD78F0531, 78F0532, 78F0533
 n = 0, 1: μ PD78F0534, 78F0535, 78F0536, 78F0537, 78F0537D

(5) SO1n output (see (a) in Figures 16-1 and 16-2)

The status of the SO1n output is as follows if bit 7 (CSIE1n) of serial operation mode register 1n (CSIM1n) is cleared to 0.

Table 16-3. SO1n Output Status

TRMD1n	DAP1n	DIR1n	SO1n Output ^{Note 1}
TRMD1n = 0 ^{Note 2}	–	–	Outputs low level ^{Note 2}
TRMD1n = 1	DAP1n = 0	–	Value of SO1n latch (low-level output)
	DAP1n = 1	DIR1n = 0	Value of bit 7 of SOTB1n
		DIR1n = 1	Value of bit 0 of SOTB1n

- Notes**
1. The actual output of the SO10/P12 or SO11/P02 pin is determined according to PM12 and P12 or PM02 and P02, as well as the SO1n output.
 2. Status after reset

Caution If a value is written to TRMD1n, DAP1n, and DIR1n, the output value of SO1n changes.

Remark n = 0: μ PD78F0531, 78F0532, 78F0533
n = 0, 1: μ PD78F0534, 78F0535, 78F0536, 78F0537, 78F0537D

CHAPTER 17 SERIAL INTERFACE IIC0

17.1 Functions of Serial Interface IIC0

Serial interface IIC0 has the following two modes.

(1) Operation stop mode

This mode is used when serial transfers are not performed. It can therefore be used to reduce power consumption.

(2) I²C bus mode (multimaster supported)

This mode is used for 8-bit data transfers with several devices via two lines: a serial clock (SCL0) line and a serial data bus (SDA0) line.

This mode complies with the I²C bus format and the master device can generate “start condition”, “address”, “transfer direction specification”, “data”, and “stop condition” data to the slave device, via the serial data bus. The slave device automatically detects these received status and data by hardware. This function can simplify the part of application program that controls the I²C bus.

Since the SCL0 and SDA0 pins are used for open drain outputs, IIC0 requires pull-up resistors for the serial clock line and the serial data bus line.

Figure 17-1 shows a block diagram of serial interface IIC0.

Figure 17-1. Block Diagram of Serial Interface IIC0

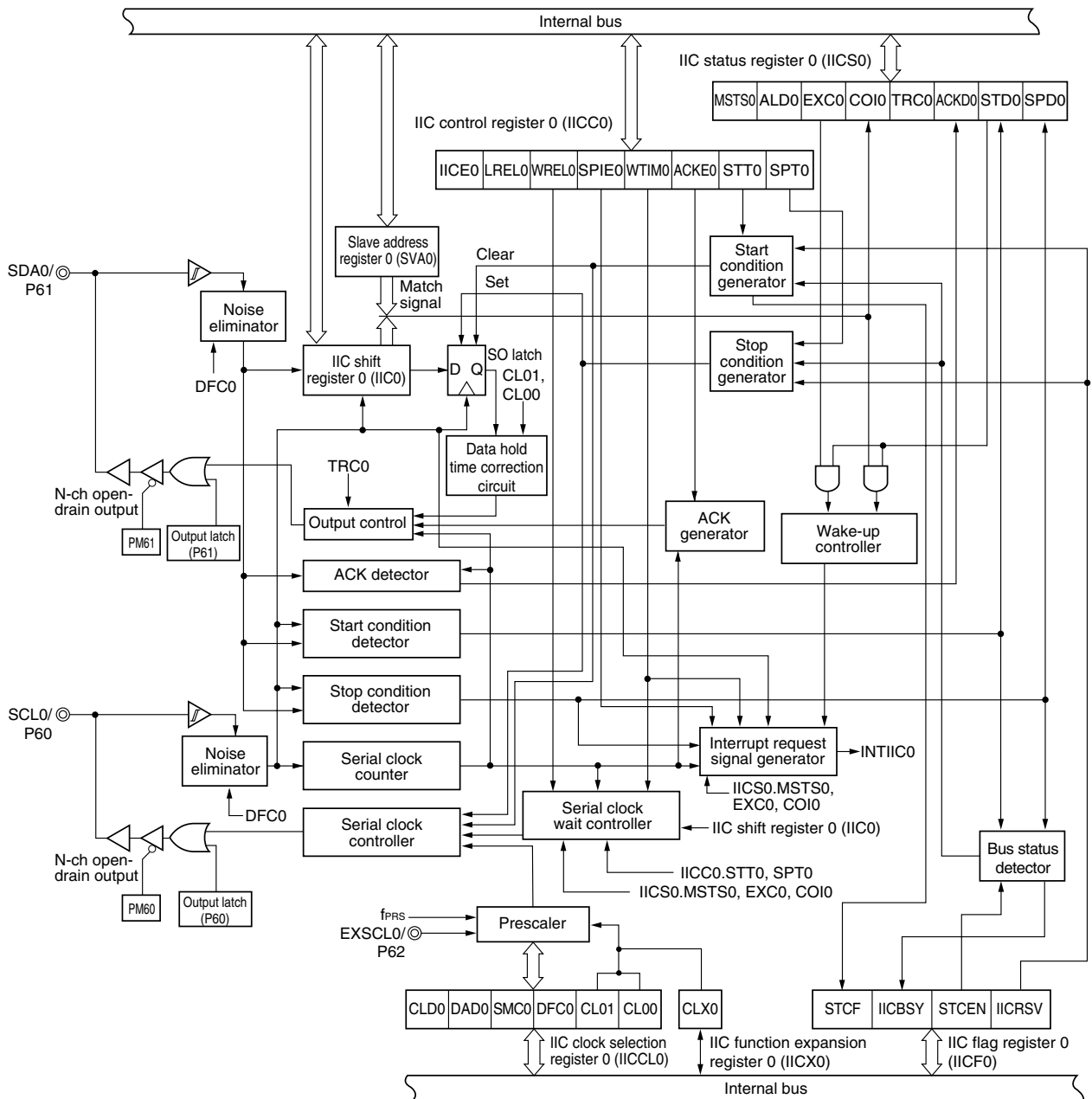
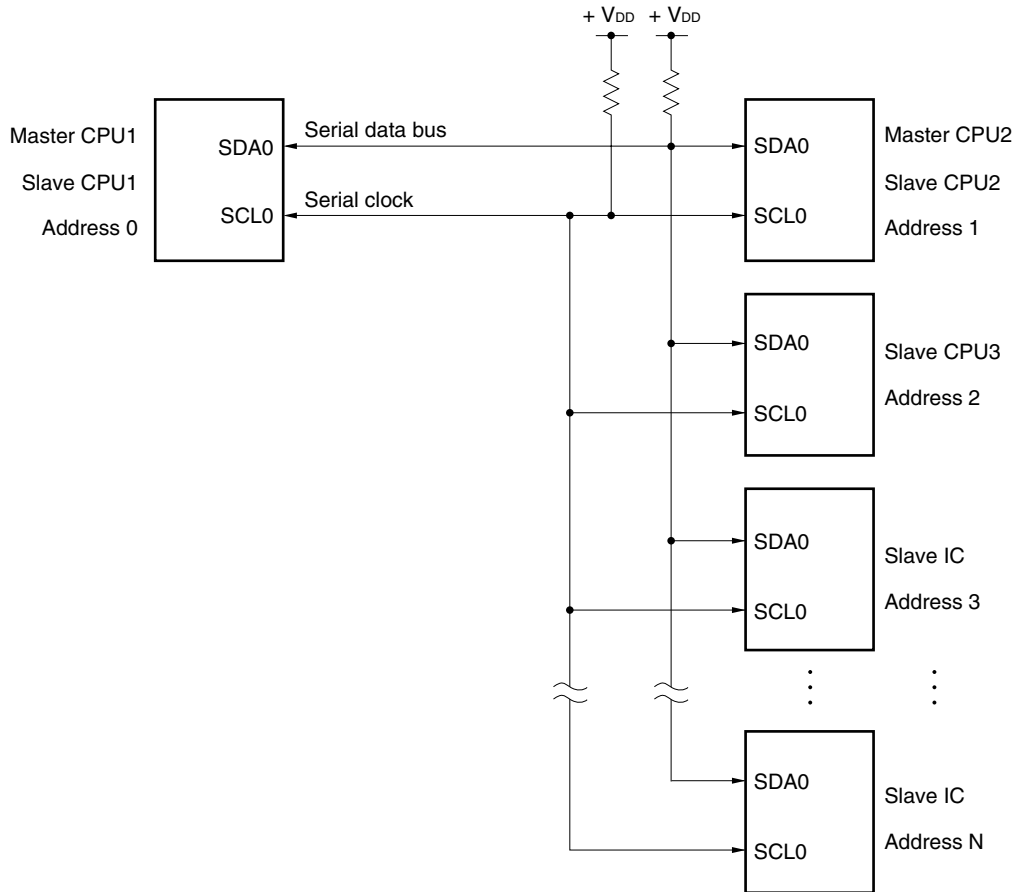

Figure 17-2 shows a serial bus configuration example.

Figure 17-2. Serial Bus Configuration Example Using I²C Bus



17.2 Configuration of Serial Interface IIC0

Serial interface IIC0 includes the following hardware.

Table 17-1. Configuration of Serial Interface IIC0

Item	Configuration
Registers	IIC shift register 0 (IIC0) Slave address register 0 (SVA0)
Control registers	IIC control register 0 (IICC0) IIC status register 0 (IICS0) IIC flag register 0 (IICF0) IIC clock selection register 0 (IICCL0) IIC function expansion register 0 (IICX0) Port mode register 6 (PM6) Port register 6 (P6)

(1) IIC shift register 0 (IIC0)

IIC0 is used to convert 8-bit serial data to 8-bit parallel data and vice versa in synchronization with the serial clock. IIC0 can be used for both transmission and reception.

The actual transmit and receive operations can be controlled by writing and reading operations to IIC0.

Cancel the wait state and start data transfer by writing data to IIC0 during the wait period.

IIC0 is set by an 8-bit memory manipulation instruction.

Reset signal generation sets IIC0 to 00H.

Figure 17-3. Format of IIC Shift Register 0 (IIC0)

Address: FFA5H After reset: 00H R/W

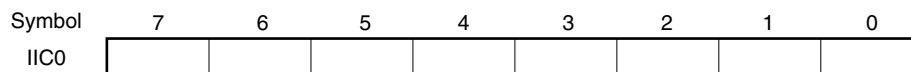

Cautions 1. Do not write data to IIC0 during data transfer.

- ★ **2. Write or read IIC0 only during the wait period. Accessing IIC0 in a communication state other than during the wait period is prohibited. When the device serves as the master, however, IIC0 can be written only once after the communication trigger bit (STT0) is set to 1.**

(2) Slave address register 0 (SVA0)

This register stores local addresses when in slave mode.

SVA0 is set by an 8-bit memory manipulation instruction.

- ★ However, rewriting to this register is prohibited while STD0 = 1 (while the start condition is detected).

Reset signal generation sets SVA0 to 00H.

Figure 17-4. Format of Slave Address Register 0 (SVA0)

Address: FFA7H After reset: 00H R/W

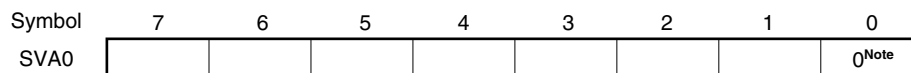

Note Bit 0 is fixed to 0.

(3) SO latch

The SO latch is used to retain the SDA0 pin's output level.

(4) Wake-up controller

This circuit generates an interrupt request (INTIIC0) when the address received by this register matches the address value set to slave address register 0 (SVA0) or when an extension code is received.

(5) Prescaler

This selects the sampling clock to be used.

(6) Serial clock counter

This counter counts the serial clocks that are output or input during transmit/receive operations and is used to verify that 8-bit data was transmitted or received.

(7) Interrupt request signal generator

This circuit controls the generation of interrupt request signals (INTIIC0).

An I²C interrupt request is generated by the following two triggers.

- Falling edge of eighth or ninth clock of the serial clock (set by WTIMO bit)
- Interrupt request generated when a stop condition is detected (set by SPIE0 bit)

Remark WTIMO bit: Bit 3 of IIC control register 0 (IICC0)

SPIE0 bit: Bit 4 of IIC control register 0 (IICC0)

(8) Serial clock controller

In master mode, this circuit generates the clock output via the SCL0 pin from a sampling clock.

(9) Serial clock wait controller

This circuit controls the wait timing.

(10) ACK generator, stop condition detector, start condition detector, and ACK detector

These circuits generate and detect each status.

(11) Data hold time correction circuit

This circuit generates the hold time for data corresponding to the falling edge of the serial clock.

(12) Start condition generator

This circuit generates a start condition when the STT0 bit is set to 1.

However, in the communication reservation disabled status (IICRSV bit = 1), when the bus is not released (IICBSY bit = 1), start condition requests are ignored and the STCF bit is set to 1.

★ (13) Stop condition generator

This circuit generates a stop condition when the SPT0 bit is set to 1.

(14) Bus status detector

This circuit detects whether or not the bus is released by detecting start conditions and stop conditions.

However, as the bus status cannot be detected immediately following operation, the initial status is set by the STCEN bit.

Remark STT0 bit: Bit 1 of IIC control register 0 (IICC0)
SPT0 bit: Bit 0 of IIC control register 0 (IICC0)
IICRSV bit: Bit 0 of IIC flag register 0
IICBSY bit: Bit 6 of IIC flag register 0
STCF bit: Bit 7 of IIC flag register 0
STCEN bit: Bit 1 of IIC flag register 0

17.3 Registers to Control Serial Interface IIC0

Serial interface IIC0 is controlled by the following seven registers.

- IIC control register 0 (IICC0)
- IIC flag register 0 (IICF0)
- IIC status register 0 (IICS0)
- IIC clock selection register 0 (IICCL0)
- IIC function expansion register 0 (IICX0)
- Port mode register 6 (PM6)
- Port register 6 (P6)

(1) IIC control register 0 (IICC0)

This register is used to enable/stop I²C operations, set wait timing, and set other I²C operations.

IICC0 is set by a 1-bit or 8-bit memory manipulation instruction. However, set the SPIE0, WTIM0, and ACKE0 bits while IICE0 bit = 0 or during the wait period. These bits can be set at the same time when the IICE0 bit is set from “0” to “1”.

Reset signal generation sets IICC0 to 00H.

Figure 17-5. Format of IIC Control Register 0 (IICC0) (1/4)

Address: FFA6H After reset: 00H R/W

Symbol	<7>	<6>	<5>	<4>	<3>	<2>	<1>	<0>
IICC0	IICE0	LRELO	WRELO	SPIE0	WTIM0	ACKE0	STT0	SPT0

IICE0	I ² C operation enable
0	Stop operation. Reset IIC status register 0 (IICS0) ^{Note 1} . Stop internal operation.
1	Enable operation.
Be sure to set this bit (1) while the SCL0 and SDA0 lines are at high level.	
Condition for clearing (IICE0 = 0)	
Condition for setting (IICE0 = 1)	
<ul style="list-style-type: none"> • Cleared by instruction • Reset 	<ul style="list-style-type: none"> • Set by instruction

★

LRELO ^{Note 2}	Exit from communications
0	Normal operation
1	This exits from the current communications and sets standby mode. This setting is automatically cleared to 0 after being executed. Its uses include cases in which a locally irrelevant extension code has been received. The SCL0 and SDA0 lines are set to high impedance. The following flags of IIC control register 0 (IICC0) and IIC status register 0 (IICS0) are cleared to 0. • STT0 • SPT0 • MST0 • EXC0 • COI0 • TRC0 • ACKD0 • STD0
The standby mode following exit from communications remains in effect until the following communications entry conditions are met.	
<ul style="list-style-type: none"> • After a stop condition is detected, restart is in master mode. • An address match or extension code reception occurs after the start condition. 	
Condition for clearing (LRELO = 0)	
Condition for setting (LRELO = 1)	
<ul style="list-style-type: none"> • Automatically cleared after execution • Reset 	<ul style="list-style-type: none"> • Set by instruction

WRELO ^{Note 2}	Wait cancellation
0	Do not cancel wait
1	Cancel wait. This setting is automatically cleared after wait is canceled.
When WRELO is set (wait canceled) during the wait period at the ninth clock pulse in the transmission status (TRC0 = 1), the SDA0 line goes into the high impedance state (TRC0 = 0).	
Condition for clearing (WRELO = 0)	
Condition for setting (WRELO = 1)	
<ul style="list-style-type: none"> • Automatically cleared after execution • Reset 	<ul style="list-style-type: none"> • Set by instruction

Notes 1. The IICS0 register, the STCF0 and IICBSY bits of the IICF0 register, and the CLD0 and DAD0 bits of the IICCL0 register are reset.

2. This flag's signal is invalid when IICE0 = 0.

★

Caution The start condition is detected immediately after I²C is enabled to operate (IICE0 = 1) while the SCL0 line is at high level and the SDA0 line is at low level. Immediately after enabling I²C to operate (IICE0 = 1), set LRELO (1) by using a 1-bit memory manipulation instruction.

Figure 17-5. Format of IIC Control Register 0 (IICC0) (2/4)

SPIE0 ^{Note 1}	Enable/disable generation of interrupt request when stop condition is detected	
0	Disable	
1	Enable	
Condition for clearing (SPIE0 = 0)		Condition for setting (SPIE0 = 1)
<ul style="list-style-type: none"> • Cleared by instruction • Reset 		<ul style="list-style-type: none"> • Set by instruction

WTIM0 ^{Note 1}	Control of wait and interrupt request generation	
0	Interrupt request is generated at the eighth clock's falling edge. Master mode: After output of eight clocks, clock output is set to low level and wait is set. Slave mode: After input of eight clocks, the clock is set to low level and wait is set for master device.	
1	Interrupt request is generated at the ninth clock's falling edge. Master mode: After output of nine clocks, clock output is set to low level and wait is set. Slave mode: After input of nine clocks, the clock is set to low level and wait is set for master device.	
An interrupt is generated at the falling edge of the ninth clock during address transfer independently of the setting of this bit. The setting of this bit is valid when the address transfer is completed. When in master mode, a wait is inserted at the falling edge of the ninth clock during address transfers. For a slave device that has received a local address, a wait is inserted at the falling edge of the ninth clock after an acknowledge (\overline{ACK}) is issued. However, when the slave device has received an extension code, a wait is inserted at the falling edge of the eighth clock.		
Condition for clearing (WTIM0 = 0)		Condition for setting (WTIM0 = 1)
<ul style="list-style-type: none"> • Cleared by instruction • Reset 		<ul style="list-style-type: none"> • Set by instruction

ACKE0 ^{Notes 1, 2}	Acknowledgment control	
0	Disable acknowledgment.	
1	Enable acknowledgment. During the ninth clock period, the SDA0 line is set to low level. However, \overline{ACK} is invalid during address transfers and other than in expansion mode.	
Condition for clearing (ACKE0 = 0)		Condition for setting (ACKE0 = 1)
<ul style="list-style-type: none"> • Cleared by instruction • Reset 		<ul style="list-style-type: none"> • Set by instruction

Notes 1. This flag's signal is invalid when IICE0 = 0.

- ★ **2.** The set value is invalid during address transfer and if the code is not an extension code. When the device serves as a slave and the addresses match, an acknowledge is generated regardless of the set value.

Figure 17-5. Format of IIC Control Register 0 (IICC0) (3/4)

STT0 ^{Note}	Start condition trigger	
0	Do not generate a start condition.	
1	<p>When bus is released (in STOP mode): Generate a start condition (for starting as master). When the SCL0 line is high level, the SDA0 line is changed from high level to low level and then the start condition is generated. Next, after the rated amount of time has elapsed, SCL0 is changed to low level.</p> <p>When a third party is communicating:</p> <ul style="list-style-type: none"> • When communication reservation function is enabled (IICRSV = 0) Functions as the start condition reservation flag. When set to 1, automatically generates a start condition after the bus is released. • When communication reservation function is disabled (IICRSV = 1) STCF is set to 1 and information that is set (1) to STT0 is cleared. No start condition is generated. <p>In the wait state (when master device): Generates a restart condition after releasing the wait.</p>	
<p>Cautions concerning set timing</p> <ul style="list-style-type: none"> • For master reception: Cannot be set to 1 during transfer. Can be set to 1 only in the waiting period when ACKE0 has been cleared to 0 and slave has been notified of final reception. • For master transmission: A start condition cannot be generated normally during the acknowledge period. Set to 1 during the wait period that follows output of the ninth clock. • Cannot be set to 1 at the same time as SPT0. • Setting STT0 to 1 and then setting it again before it is cleared to 0 is prohibited. 		
Condition for clearing (STT0 = 0)		Condition for setting (STT0 = 1)
<ul style="list-style-type: none"> • Cleared by setting SST0 to 1 while communication reservation is prohibited. • Cleared by loss in arbitration • Cleared after start condition is generated by master device • Cleared by LREL0 = 1 (exit from communications) • When IICE0 = 0 (operation stop) • Reset 		<ul style="list-style-type: none"> • Set by instruction

Note This flag's signal is invalid when IICE0 = 0.

Remarks 1. Bit 1 (STT0) becomes 0 when it is read after data setting.

2. IICRSV: Bit 0 of IIC flag register (IICF0)

STCF: Bit 7 of IIC flag register (IICF0)

Figure 17-5. Format of IIC Control Register 0 (IICC0) (4/4)

SPT0	Stop condition trigger				
0	Stop condition is not generated.				
1	Stop condition is generated (termination of master device's transfer). After the SDA0 line goes to low level, either set the SCL0 line to high level or wait until it goes to high level. Next, after the rated amount of time has elapsed, the SDA0 line changes from low level to high level and a stop condition is generated.				
Cautions concerning set timing <ul style="list-style-type: none"> • For master reception: Cannot be set to 1 during transfer. Can be set to 1 only in the waiting period when ACKE0 has been cleared to 0 and slave has been notified of final reception. • For master transmission: A stop condition cannot be generated normally during the acknowledge period. Therefore, set it during the wait period that follows output of the ninth clock. • Cannot be set to 1 at the same time as STT0. • SPT0 can be set to 1 only when in master mode^{Note}. • When WTIM0 has been cleared to 0, if SPT0 is set to 1 during the wait period that follows output of eight clocks, note that a stop condition will be generated during the high-level period of the ninth clock. WTIM0 should be changed from 0 to 1 during the wait period following the output of eight clocks, and SPT0 should be set to 1 during the wait period that follows the output of the ninth clock. • Setting SPT0 to 1 and then setting it again before it is cleared to 0 is prohibited. 					
<table border="1"> <thead> <tr> <th>Condition for clearing (SPT0 = 0)</th> <th>Condition for setting (SPT0 = 1)</th> </tr> </thead> <tbody> <tr> <td> <ul style="list-style-type: none"> • Cleared by loss in arbitration • Automatically cleared after stop condition is detected • Cleared by LREL0 = 1 (exit from communications) • When IICE0 = 0 (operation stop) • Reset </td> <td> <ul style="list-style-type: none"> • Set by instruction </td> </tr> </tbody> </table>		Condition for clearing (SPT0 = 0)	Condition for setting (SPT0 = 1)	<ul style="list-style-type: none"> • Cleared by loss in arbitration • Automatically cleared after stop condition is detected • Cleared by LREL0 = 1 (exit from communications) • When IICE0 = 0 (operation stop) • Reset 	<ul style="list-style-type: none"> • Set by instruction
Condition for clearing (SPT0 = 0)	Condition for setting (SPT0 = 1)				
<ul style="list-style-type: none"> • Cleared by loss in arbitration • Automatically cleared after stop condition is detected • Cleared by LREL0 = 1 (exit from communications) • When IICE0 = 0 (operation stop) • Reset 	<ul style="list-style-type: none"> • Set by instruction 				

Note Set SPT0 to 1 only in master mode. However, SPT0 must be set to 1 and a stop condition generated before the first stop condition is detected following the switch to the operation enabled status. For details, see **17.5.15 Other cautions.**

Caution When bit 3 (TRC0) of IIC status register 0 (IICS0) is set to 1, WREL0 is set to 1 during the ninth clock and wait is canceled, after which TRC0 is cleared and the SDA0 line is set to high impedance.

Remark Bit 0 (SPT0) becomes 0 when it is read after data setting.

(2) IIC status register 0 (IICS0)

This register indicates the status of I²C.

IICS0 is read by a 1-bit or 8-bit memory manipulation instruction only when STT0 = 1 and during the wait period.

Reset signal generation sets IICS0 to 00H.

Caution If data is read from IICS0, a wait cycle is generated. Do not read data from IICS0 when the CPU is operating on the subsystem clock and the peripheral hardware clock is stopped. For details, see CHAPTER 31 CAUTIONS FOR WAIT.

Figure 17-6. Format of IIC Status Register 0 (IICS0) (1/3)

Address: FFAAH After reset: 00H R

Symbol	<7>	<6>	<5>	<4>	<3>	<2>	<1>	<0>
IICS0	MSTS0	ALD0	EXC0	COI0	TRC0	ACKD0	STD0	SPD0

MSTS0	Master device status	
0	Slave device status or communication standby status	
1	Master device communication status	
Condition for clearing (MSTS0 = 0)		Condition for setting (MSTS0 = 1)
<ul style="list-style-type: none"> • When a stop condition is detected • When ALD0 = 1 (arbitration loss) • Cleared by LREL0 = 1 (exit from communications) • When IICE0 changes from 1 to 0 (operation stop) • Reset 		<ul style="list-style-type: none"> • When a start condition is generated

ALD0	Detection of arbitration loss	
0	This status means either that there was no arbitration or that the arbitration result was a “win”.	
1	This status indicates the arbitration result was a “loss”. MSTS0 is cleared.	
Condition for clearing (ALD0 = 0)		Condition for setting (ALD0 = 1)
<ul style="list-style-type: none"> • Automatically cleared after IICS0 is read^{Note} • When IICE0 changes from 1 to 0 (operation stop) • Reset 		<ul style="list-style-type: none"> • When the arbitration result is a “loss”.

EXC0	Detection of extension code reception	
0	Extension code was not received.	
1	Extension code was received.	
Condition for clearing (EXC0 = 0)		Condition for setting (EXC0 = 1)
<ul style="list-style-type: none"> • When a start condition is detected • When a stop condition is detected • Cleared by LREL0 = 1 (exit from communications) • When IICE0 changes from 1 to 0 (operation stop) • Reset 		<ul style="list-style-type: none"> • When the higher four bits of the received address data is either “0000” or “1111” (set at the rising edge of the eighth clock).

Note This register is also cleared when a 1-bit memory manipulation instruction is executed for bits other than IICS0. Therefore, when using the ALD0 bit, read the data of this bit before the data of the other bits.

Remark LREL0: Bit 6 of IIC control register 0 (IICC0)
IICE0: Bit 7 of IIC control register 0 (IICC0)

Figure 17-6. Format of IIC Status Register 0 (IICS0) (2/3)

COI0	Detection of matching addresses	
0	Addresses do not match.	
1	Addresses match.	
Condition for clearing (COI0 = 0)		Condition for setting (COI0 = 1)
<ul style="list-style-type: none"> • When a start condition is detected • When a stop condition is detected • Cleared by LREL0 = 1 (exit from communications) • When IICE0 changes from 1 to 0 (operation stop) • Reset 		<ul style="list-style-type: none"> • When the received address matches the local address (slave address register 0 (SVA0)) (set at the rising edge of the eighth clock).

TRC0	Detection of transmit/receive status	
0	Receive status (other than transmit status). The SDA0 line is set for high impedance.	
1	Transmit status. The value in the SO0 latch is enabled for output to the SDA0 line (valid starting at the falling edge of the first byte's ninth clock).	
Condition for clearing (TRC0 = 0)		Condition for setting (TRC0 = 1)
<p><Both master and slave></p> <ul style="list-style-type: none"> • When a stop condition is detected • Cleared by LREL0 = 1 (exit from communications) • When IICE0 changes from 1 to 0 (operation stop) • Cleared by WREL0 = 1^{Note} (wait cancel) • When ALD0 changes from 0 to 1 (arbitration loss) • Reset <p><Master></p> <ul style="list-style-type: none"> • When "1" is output to the first byte's LSB (transfer direction specification bit) <p><Slave></p> <ul style="list-style-type: none"> • When a start condition is detected • When "0" is input to the first byte's LSB (transfer direction specification bit) <p><When not used for communication></p>		<p><Master></p> <ul style="list-style-type: none"> • When a start condition is generated • When "0" is output to the first byte's LSB (transfer direction specification bit) <p><Slave></p> <ul style="list-style-type: none"> • When "1" is input to the first byte's LSB (transfer direction specification bit)

Note If the wait status is canceled by setting bit 5 (WREL0) of IIC control register 0 (IICC0) to 1 at the ninth clock when bit 3 (TRC0) of IIC status register 0 (IICS0) is 1, TRC0 is cleared, and the SDA0 line goes into a high-impedance state.

Remark LREL0: Bit 6 of IIC control register 0 (IICC0)
IICE0: Bit 7 of IIC control register 0 (IICC0)

Figure 17-6. Format of IIC Status Register 0 (IICS0) (3/3)

ACKD0	Detection of acknowledge ($\overline{\text{ACK}}$)	
0	Acknowledge was not detected.	
1	Acknowledge was detected.	
Condition for clearing (ACKD0 = 0)		Condition for setting (ACKD0 = 1)
<ul style="list-style-type: none"> • When a stop condition is detected • At the rising edge of the next byte's first clock • Cleared by LREL0 = 1 (exit from communications) • When IICE0 changes from 1 to 0 (operation stop) • Reset 		<ul style="list-style-type: none"> • After the SDA0 line is set to low level at the rising edge of SCL0's ninth clock

STD0	Detection of start condition	
0	Start condition was not detected.	
1	Start condition was detected. This indicates that the address transfer period is in effect.	
Condition for clearing (STD0 = 0)		Condition for setting (STD0 = 1)
<ul style="list-style-type: none"> • When a stop condition is detected • At the rising edge of the next byte's first clock following address transfer • Cleared by LREL0 = 1 (exit from communications) • When IICE0 changes from 1 to 0 (operation stop) • Reset 		<ul style="list-style-type: none"> • When a start condition is detected

SPD0	Detection of stop condition	
0	Stop condition was not detected.	
1	Stop condition was detected. The master device's communication is terminated and the bus is released.	
Condition for clearing (SPD0 = 0)		Condition for setting (SPD0 = 1)
<ul style="list-style-type: none"> • At the rising edge of the address transfer byte's first clock following setting of this bit and detection of a start condition • When IICE0 changes from 1 to 0 (operation stop) • Reset 		<ul style="list-style-type: none"> • When a stop condition is detected

Remark LREL0: Bit 6 of IIC control register 0 (IICC0)

IICE0: Bit 7 of IIC control register 0 (IICC0)

(3) IIC flag register 0 (IICF0)

This register sets the operation mode of I²C and indicates the status of the I²C bus.

IICF0 is set by a 1-bit or 8-bit memory manipulation instruction. However, the STCF and IICBSY bits are read-only.

The IICRSV bit can be used to enable/disable the communication reservation function (see **17.5.14 Communication reservation**).

STCEN can be used to set the initial value of the IICBSY bit (see **17.5.15 Other cautions**).

IICRSV and STCEN can be written only when the operation of I²C is disabled (bit 7 (IICE0) of IIC control register 0 (IICC0) = 0). When operation is enabled, the IICF0 register can be read.

Reset signal generation sets IICF0 to 00H.

Figure 17-7. Format of IIC Flag Register 0 (IICF0)

Address: FFABH After reset: 00H R/W^{Note}

Symbol	<7>	<6>	5	4	3	2	<1>	<0>
IICF0	STCF	IICBSY	0	0	0	0	STCEN	IICRSV

STCF	STT0 clear flag
0	Generate start condition
1	Start condition generation unsuccessful: clear STT0 flag
Condition for clearing (STCF = 0)	
<ul style="list-style-type: none"> • Cleared by STT0 = 1 • When IICE0 = 0 (operation stop) • Reset 	
Condition for setting (STCF = 1)	
<ul style="list-style-type: none"> • Generating start condition unsuccessful and STT0 cleared to 0 when communication reservation is disabled (IICRSV = 1). 	

★

IICBSY	I ² C bus status flag
0	Bus release status (communication initial status when STCEN0 = 1)
1	Bus communication status (communication initial status when STCEN0 = 0)
Condition for clearing (IICBSY = 0)	
<ul style="list-style-type: none"> • Detection of stop condition • When IICE0 = 0 (operation stop) • Reset 	
Condition for setting (IICBSY = 1)	
<ul style="list-style-type: none"> • Detection of start condition • Setting of IICE0 when STCEN = 0 	

★

STCEN	Initial start enable trigger
0	After operation is enabled (IICE0 = 1), enable generation of a start condition upon detection of a stop condition.
1	After operation is enabled (IICE0 = 1), enable generation of a start condition without detecting a stop condition.
Condition for clearing (STCEN = 0)	
<ul style="list-style-type: none"> • Detection of stop condition • Reset 	
Condition for setting (STCEN = 1)	
<ul style="list-style-type: none"> • Set by instruction 	

IICRSV	Communication reservation function disable bit
0	Enable communication reservation
1	Disable communication reservation
Condition for clearing (IICRSV = 0)	
<ul style="list-style-type: none"> • Cleared by instruction • Reset 	
Condition for setting (IICRSV = 1)	
<ul style="list-style-type: none"> • Set by instruction 	

Note Bits 6 and 7 are read-only.

- Cautions**
1. Write to STCEN only when the operation is stopped (IICE0 = 0).
 2. As the bus release status (IICBSY = 0) is recognized regardless of the actual bus status when STCEN = 1, when generating the first start condition (STT0 = 1), it is necessary to verify that no third party communications are in progress in order to prevent such communications from being destroyed.
 3. Write to IICRSV only when the operation is stopped (IICE0 = 0).

Remark STT0: Bit 1 of IIC control register 0 (IICC0)
 IICE0: Bit 7 of IIC control register 0 (IICC0)

(4) IIC clock selection register 0 (IICCL0)

This register is used to set the transfer clock for the I²C bus.

IICCL0 is set by a 1-bit or 8-bit memory manipulation instruction. However, the CLD0 and DAD0 bits are read-only. The SMC0, CL01, and CL00 bits are set in combination with bit 0 (CLX0) of IIC function expansion register 0 (IICX0) (see 17.3 (6) I²C transfer clock setting method).

★ Set IICCL0 while bit 7 (IICE0) of IIC control register 0 (IICC0) is 0.

Reset signal generation sets IICCL0 to 00H.

Figure 17-8. Format of IIC Clock Selection Register 0 (IICCL0)

Address: FFA8H After reset: 00H R/W^{Note}

Symbol	7	6	<5>	<4>	<3>	<2>	1	0
IICCL0	0	0	CLD0	DAD0	SMC0	DFC0	CL01	CL00

CLD0	Detection of SCL0 pin level (valid only when IICE0 = 1)	
0	The SCL0 pin was detected at low level.	
1	The SCL0 pin was detected at high level.	
Condition for clearing (CLD0 = 0)		Condition for setting (CLD0 = 1)
<ul style="list-style-type: none"> When the SCL0 pin is at low level When IICE0 = 0 (operation stop) Reset 		<ul style="list-style-type: none"> When the SCL0 pin is at high level

DAD0	Detection of SDA0 pin level (valid only when IICE0 = 1)	
0	The SDA0 pin was detected at low level.	
1	The SDA0 pin was detected at high level.	
Condition for clearing (DAD0 = 0)		Condition for setting (DAD0 = 1)
<ul style="list-style-type: none"> When the SDA0 pin is at low level When IICE0 = 0 (operation stop) Reset 		<ul style="list-style-type: none"> When the SDA0 pin is at high level

SMC0	Operation mode switching
0	Operates in standard mode.
1	Operates in high-speed mode.

DFC0	Digital filter operation control
0	Digital filter off.
1	Digital filter on.
Digital filter can be used only in high-speed mode. In high-speed mode, the transfer clock does not vary regardless of DFC0 bit set (1)/clear (0). The digital filter is used for noise elimination in high-speed mode.	

Note Bits 4 and 5 are read-only.

Remark IICE0: Bit 7 of IIC control register 0 (IICC0)

(5) IIC function expansion register 0 (IICX0)

This register sets the function expansion of I²C.

IICX0 is set by a 1-bit or 8-bit memory manipulation instruction. The CLX0 bit is set in combination with bits 3, 1, and 0 (SMC0, CL01, and CL00) of IIC clock selection register 0 (IICCL0) (see **17.3 (6) I²C transfer clock setting method**).

Set IICX0 while bit 7 (IICE0) of IIC control register 0 (IICC0) is 0.

Reset signal generation sets IICX0 to 00H.

Figure 17-9. Format of IIC Function Expansion Register 0 (IICX0)

Address: FFA9H	After reset: 00H	R/W						
Symbol	7	6	5	4	3	2	1	<0>
IICX0	0	0	0	0	0	0	0	CLX0

(6) I²C transfer clock setting method

The I²C transfer clock frequency (f_{SCL}) is calculated using the following expression.

$$f_{SCL} = 1/(m \times T + t_R + t_F)$$

- ★ m = 12, 18, 24, 44, 66, 86 (see **Table 17-2 Selection Clock Setting**)
- ★ T: 1/f_w
- t_R: SCL0 rise time
- t_F: SCL0 fall time

★ For example, the I²C transfer clock frequency (f_{SCL}) when $f_w = f_{PRS}/2 = 4.19$ MHz, $m = 86$, $t_R = 200$ ns, and $t_F = 50$ ns is calculated using following expression.

★
$$f_{SCL} = 1/(88 \times 238.7 \text{ ns} + 200 \text{ ns} + 50 \text{ ns}) \cong 48.1 \text{ kHz}$$

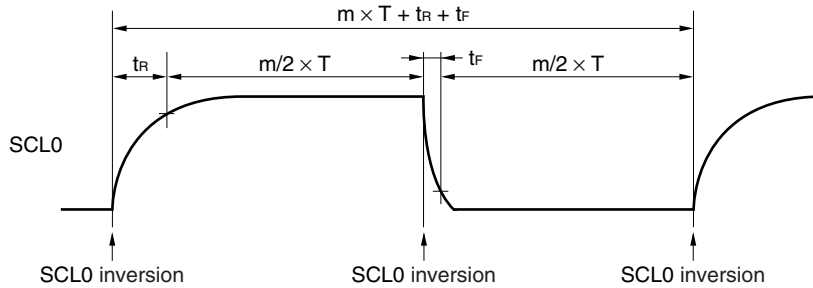

The selection clock is set using a combination of bits 3, 1, and 0 (SMC0, CL01, and CL00) of IIC clock selection register 0 (IICCL0) and bit 0 (CLX0) of IIC function expansion register 0 (IICX0).

★ **Table 17-2. Selection Clock Setting**

IICX0 Bit 0 CLX0	IICCL0			Selection Clock (f_w)	Transfer Clock (f_w/m)	Settable Selection Clock (f_w) Range	Operation Mode
	Bit 3 SMC0	Bit 1 CL01	Bit 0 CL00				
0	0	0	0	$f_{PRS}/2$	$f_w/44$	2.00 to 4.19 MHz	Normal mode (SMC0 bit = 0)
0	0	0	1	$f_{PRS}/2$	$f_w/86$	4.19 to 8.38 MHz	
0	0	1	0	$f_{PRS}/4$	$f_w/86$		
0	0	1	1	f_{EXSCL0}	$f_w/66$	6.4 MHz	
0	1	0	×	$f_{PRS}/2$	$f_w/24$	4.00 to 8.38 MHz	High-speed mode (SMC0 bit = 1)
0	1	1	0	$f_{PRS}/4$	$f_w/24$		
0	1	1	1	f_{EXSCL0}	$f_w/18$	6.4 MHz	
1	0	×	×	Setting prohibited			
1	1	0	×	$f_{PRS}/2$	$f_w/12$	4.00 to 4.19 MHz	High-speed mode (SMC0 bit = 1)
1	1	1	0	$f_{PRS}/4$	$f_w/12$		
1	1	1	1	Setting prohibited			

Caution Determine the transfer clock frequency of I²C by using CLX0, SMC0, CL01, and CL00 before enabling the operation (by setting bit 7 (IICE0) of IIC control register 0 (IICC0) to 1). To change the transfer clock frequency, clear IICE0 once to 0.

- Remarks**
1. ×: don't care
 2. f_{PRS} : Peripheral hardware clock frequency
 3. f_{EXSCL0} : External clock frequency from EXSCL0 pin

(7) Port mode register 6 (PM6)

This register sets the input/output of port 6 in 1-bit units.

When using the P60/SCL0 pin as clock I/O and the P61/SDA0 pin as serial data I/O, clear PM60 and PM61, and the output latches of P60 and P61 to 0.

Set IICE0 (bit 7 of IIC control register 0 (IICC0)) to 1 before setting the output mode because the P60/SCL0 and P61/SDA0 pins output a low level (fixed) when IICE0 is 0.

PM6 is set by a 1-bit or 8-bit memory manipulation instruction.

Reset signal generation sets PM6 to FFH.

Figure 17-10. Format of Port Mode Register 6 (PM6)

Address: FF26H After reset: FFH R/W

Symbol	7	6	5	4	3	2	1	0
PM6	1	1	1	1	PM63	PM62	PM61	PM60

PM6n	P6n pin I/O mode selection (n = 0 to 3)
0	Output mode (output buffer on)
1	Input mode (output buffer off)

17.4 I²C Bus Mode Functions

17.4.1 Pin configuration

The serial clock pin (SCL0) and serial data bus pin (SDA0) are configured as follows.

- (1) SCL0 This pin is used for serial clock input and output.
This pin is an N-ch open-drain output for both master and slave devices. Input is Schmitt input.
- (2) SDA0 This pin is used for serial data input and output.
This pin is an N-ch open-drain output for both master and slave devices. Input is Schmitt input.

Since outputs from the serial clock line and the serial data bus line are N-ch open-drain outputs, an external pull-up resistor is required.

Figure 17-11. Pin Configuration Diagram

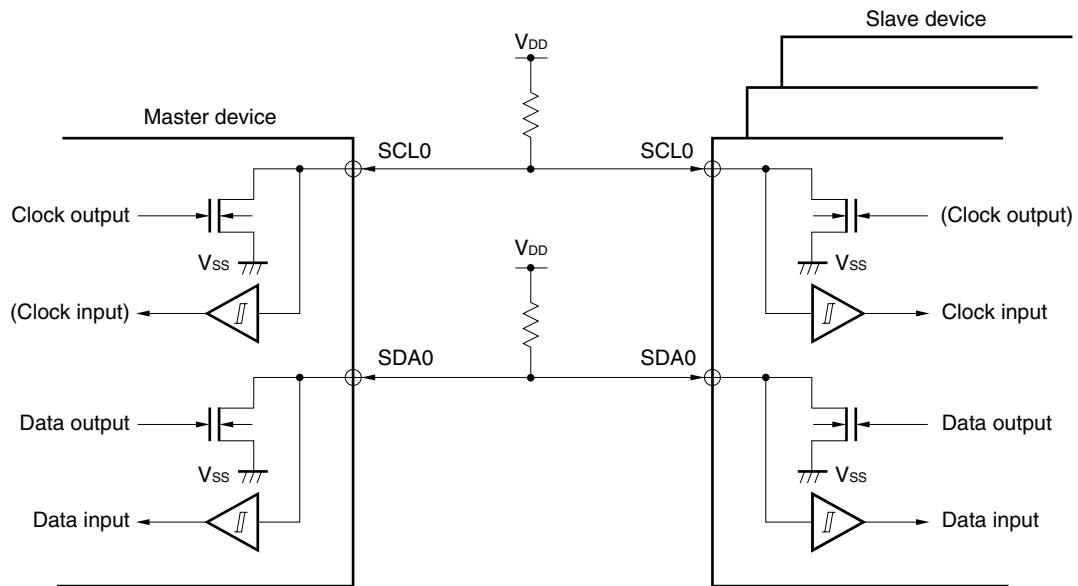

17.5 I²C Bus Definitions and Control Methods

The following section describes the I²C bus's serial data communication format and the signals used by the I²C bus. Figure 17-12 shows the transfer timing for the "start condition", "address", "data", and "stop condition" output via the I²C bus's serial data bus.

Figure 17-12. I²C Bus Serial Data Transfer Timing

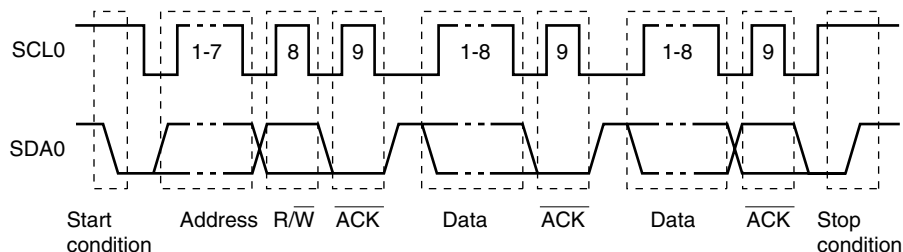

The master device generates the start condition, slave address, and stop condition.

The acknowledge ($\overline{\text{ACK}}$) can be generated by either the master or slave device (normally, it is output by the device that receives 8-bit data).

The serial clock (SCL0) is continuously output by the master device. However, in the slave device, the SCL0's low level period can be extended and a wait can be inserted.

17.5.1 Start conditions

A start condition is met when the SCL0 pin is at high level and the SDA0 pin changes from high level to low level. The start conditions for the SCL0 pin and SDA0 pin are signals that the master device generates to the slave device when starting a serial transfer. When the device is used as a slave, start conditions can be detected.

Figure 17-13. Start Conditions

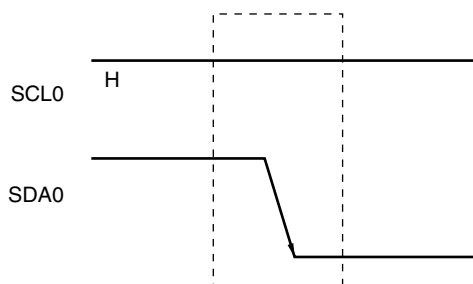

A start condition is output when bit 1 (STT0) of IIC control register 0 (IICC0) is set (to 1) after a stop condition has been detected (SPD0: Bit 0 = 1 in IIC status register 0 (IICS0)). When a start condition is detected, bit 1 (STD0) of IICS0 is set (to 1).

17.5.2 Addresses

The address is defined by the 7 bits of data that follow the start condition.

An address is a 7-bit data segment that is output in order to select one of the slave devices that are connected to the master device via the bus lines. Therefore, each slave device connected via the bus lines must have a unique address.

The slave devices include hardware that detects the start condition and checks whether or not the 7-bit address data matches the data values stored in slave address register 0 (SVA0). If the address data matches the SVA0 values, the slave device is selected and communicates with the master device until the master device generates a start condition or stop condition.

Figure 17-14. Address

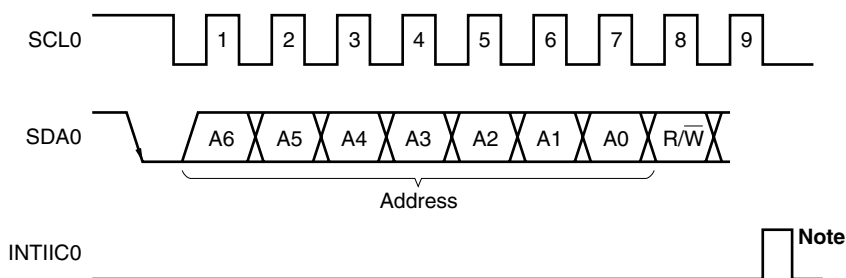

Note INTIIC0 is not issued if data other than a local address or extension code is received during slave device operation.

The slave address and the eighth bit, which specifies the transfer direction as described in **17.5.3 Transfer direction specification** below, are together written to IIC shift register 0 (IIC0) and are then output. Received addresses are written to IIC0.

The slave address is assigned to the higher 7 bits of IIC0.

17.5.3 Transfer direction specification

In addition to the 7-bit address data, the master device sends 1 bit that specifies the transfer direction.

When this transfer direction specification bit has a value of “0”, it indicates that the master device is transmitting data to a slave device. When the transfer direction specification bit has a value of “1”, it indicates that the master device is receiving data from a slave device.

Figure 17-15. Transfer Direction Specification

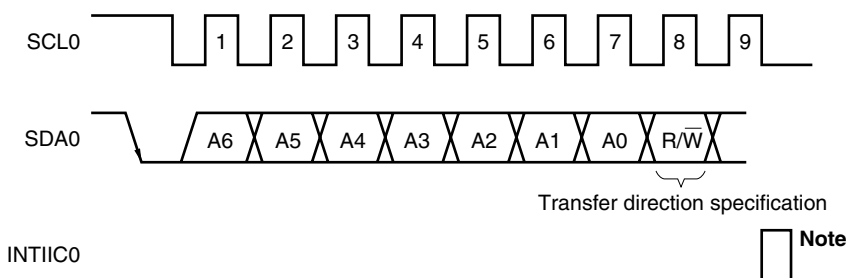

Note INTIIC0 is not issued if data other than a local address or extension code is received during slave device operation.

17.5.4 Acknowledge ($\overline{\text{ACK}}$)

$\overline{\text{ACK}}$ is used to check the status of serial data at the transmission and reception sides.

The reception side returns $\overline{\text{ACK}}$ each time it has received 8-bit data.

The transmission side usually receives $\overline{\text{ACK}}$ after transmitting 8-bit data. When $\overline{\text{ACK}}$ is returned from the reception side, it is assumed that reception has been correctly performed and processing is continued. Whether $\overline{\text{ACK}}$ has been detected can be checked by using bit 2 (ACKD0) of IIC status register 0 (IICS0).

When the master receives the last data item, it does not return $\overline{\text{ACK}}$ and instead generates a stop condition. If a slave does not return $\overline{\text{ACK}}$ after receiving data, the master outputs a stop condition or restart condition and stops transmission. If $\overline{\text{ACK}}$ is not returned, the possible causes are as follows.

- <1> Reception was not performed normally.
- <2> The final data item was received.
- ★ <3> The reception side specified by the address does not exist.

To generate $\overline{\text{ACK}}$, the reception side makes the SDA0 line low at the ninth clock (indicating normal reception).

Automatic generation of $\overline{\text{ACK}}$ is enabled by setting bit 2 (ACKE0) of IIC control register 0 (IICC0) to 1. Bit 3 (TRC0) of the IICS0 register is set by the data of the eighth bit that follows 7-bit address information. Usually, set ACEK0 to 1 for reception (TRC0 = 0).

If a slave can receive no more data during reception (TRC0 = 0) or does not require the next data item, then the slave must inform the master, by clearing ACEK0 to 0, that it will not receive any more data.

When the master does not require the next data item during reception (TRC0 = 0), it must clear ACEK0 to 0 so that $\overline{\text{ACK}}$ is not generated. In this way, the master informs a slave at the transmission side that it does not require any more data (transmission will be stopped).

Figure 17-16. $\overline{\text{ACK}}$

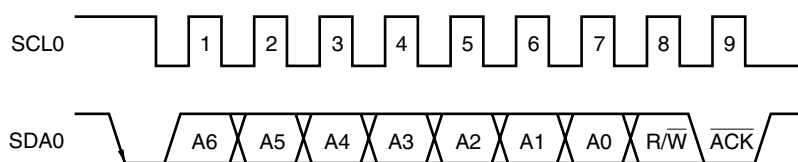

When the local address is received, $\overline{\text{ACK}}$ is automatically generated, regardless of the value of ACEK0. When an address other than that of the local address is received, $\overline{\text{ACK}}$ is not generated (NACK).

When an extension code is received, $\overline{\text{ACK}}$ is generated if ACEK0 is set to 1 in advance.

How $\overline{\text{ACK}}$ is generated when data is received differs as follows depending on the setting of the wait timing.

- When 8-clock wait state is selected (bit 3 (WTIM0) of IICC0 register = 0):
By setting ACEK0 to 1 before releasing the wait state, $\overline{\text{ACK}}$ is generated at the falling edge of the eighth clock of the SCL0 pin.
- When 9-clock wait state is selected (bit 3 (WTIM0) of IICC0 register = 1):
 $\overline{\text{ACK}}$ is generated by setting ACEK0 to 1 in advance.

17.5.5 Stop condition

When the SCL0 pin is at high level, changing the SDA0 pin from low level to high level generates a stop condition.

A stop condition is a signal that the master device generates to the slave device when serial transfer has been completed. When the device is used as a slave, stop conditions can be detected.

Figure 17-17. Stop Condition

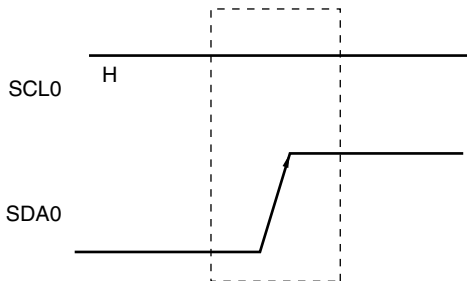

A stop condition is generated when bit 0 (SPT0) of IIC control register 0 (IICC0) is set to 1. When the stop condition is detected, bit 0 (SPD0) of IIC status register 0 (IICS0) is set to 1 and INTIIC0 is generated when bit 4 (SPIE0) of IICC0 is set to 1.

17.5.6 Wait

The wait is used to notify the communication partner that a device (master or slave) is preparing to transmit or receive data (i.e., is in a wait state).

Setting the SCL0 pin to low level notifies the communication partner of the wait state. When wait state has been canceled for both the master and slave devices, the next data transfer can begin.

Figure 17-18. Wait (1/2)

(1) When master device has a nine-clock wait and slave device has an eight-clock wait (master transmits, slave receives, and ACKE0 = 1)

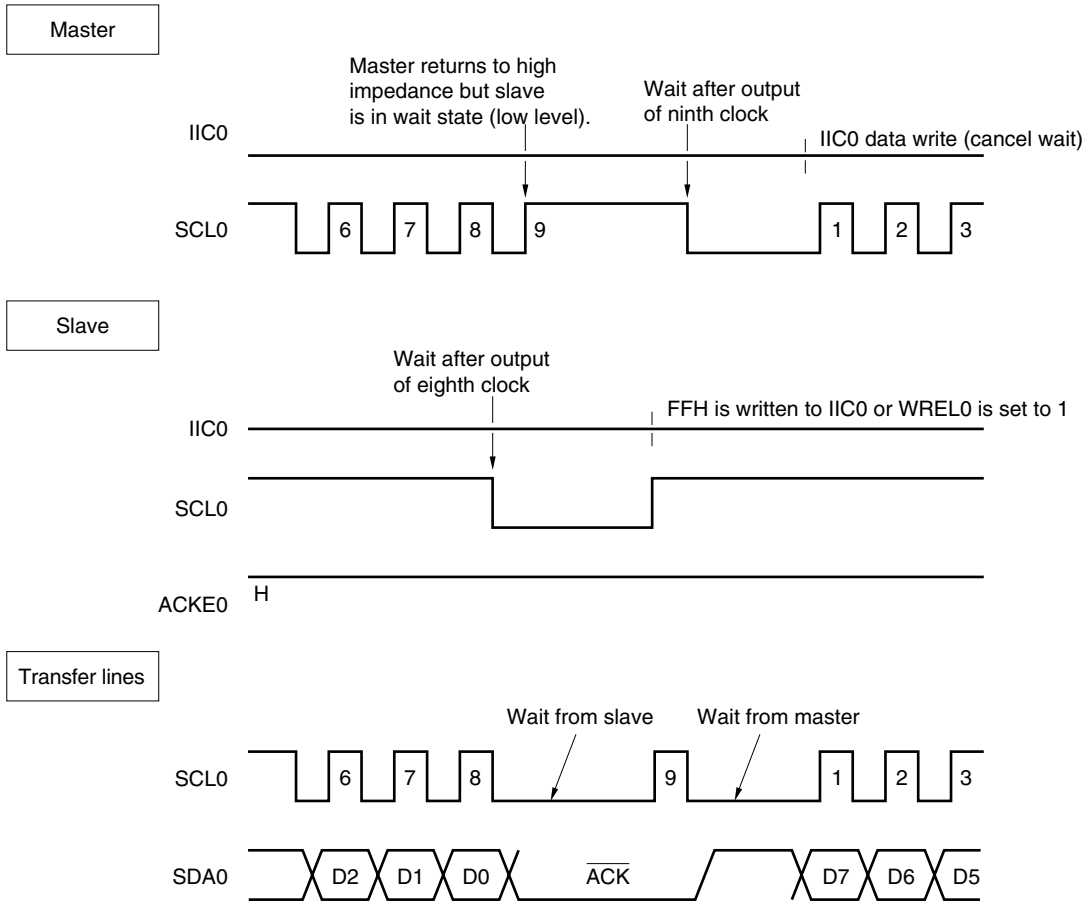
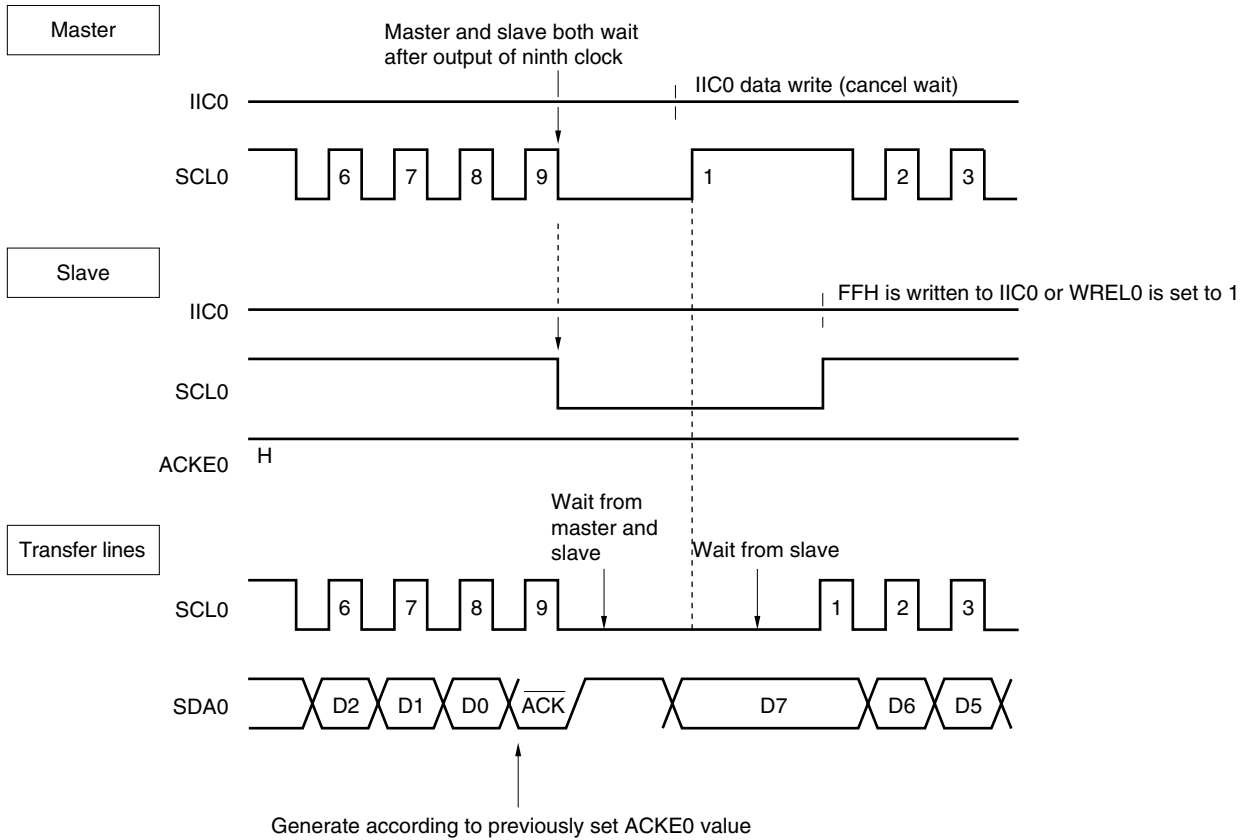

Figure 17-18. Wait (2/2)

(2) When master and slave devices both have a nine-clock wait (master transmits, slave receives, and ACKE0 = 1)



Remark ACKE0: Bit 2 of IIC control register 0 (IICC0)
WRELO: Bit 5 of IIC control register 0 (IICC0)

A wait may be automatically generated depending on the setting of bit 3 (WTIM0) of IIC control register 0 (IICC0). Normally, the receiving side cancels the wait state when bit 5 (WRELO) of IICC0 is set to 1 or when FFH is written to IIC shift register 0 (IIC0), and the transmitting side cancels the wait state when data is written to IIC0.

The master device can also cancel the wait state via either of the following methods.

- By setting bit 1 (STT0) of IICC0 to 1
- By setting bit 0 (SPT0) of IICC0 to 1

★ 17.5.7 Canceling wait

The I²C usually cancels a wait state by the following processing.

- Writing data to IIC shift register 0 (IIC0)
- Setting bit 5 (WREL0) of IIC control register 0 (IICC0) (canceling wait)
- Setting bit 1 (STT0) of IIC0 register (generating start condition)^{Note}
- Setting bit 0 (SPT0) of IIC0 register (generating stop condition)^{Note}

Note Master only

When the above wait canceling processing is executed, the I²C cancels the wait state and communication is resumed.

To cancel a wait state and transmit data (including addresses), write the data to IIC0.

To receive data after canceling a wait state, or to complete data transmission, set bit 5 (WREL0) of the IIC0 control register 0 (IICC0) to 1.

To generate a restart condition after canceling a wait state, set bit 1 (STT0) of IICC0 to 1.

To generate a stop condition after canceling a wait state, set bit 0 (SPT0) of IICC0 to 1.

Execute the canceling processing only once for one wait state.

If, for example, data is written to IIC0 after canceling a wait state by setting WREL0 to 1, an incorrect value may be output to SDA0 because the timing for changing the SDA0 line conflicts with the timing for writing IIC0.

In addition to the above, communication is stopped if IICE0 is cleared to 0 when communication has been aborted, so that the wait state can be canceled.

If the I²C bus has deadlocked due to noise, processing is saved from communication by setting bit 6 (LREL0) of IICC0, so that the wait state can be canceled.

17.5.8 Interrupt request (INTIIC0) generation timing and wait control

The setting of bit 3 (WTIM0) of IIC control register 0 (IICC0) determines the timing by which INTIIC0 is generated and the corresponding wait control, as shown in Table 17-3.

Table 17-3. INTIIC0 Generation Timing and Wait Control

WTIM0	During Slave Device Operation			During Master Device Operation		
	Address	Data Reception	Data Transmission	Address	Data Reception	Data Transmission
0	9 ^{Notes 1, 2}	8 ^{Note 2}	8 ^{Note 2}	9	8	8
1	9 ^{Notes 1, 2}	9 ^{Note 2}	9 ^{Note 2}	9	9	9

Notes 1. The slave device's INTIIC0 signal and wait period occurs at the falling edge of the ninth clock only when there is a match with the address set to slave address register 0 (SVA0).

At this point, \overline{ACK} is generated regardless of the value set to IICC0's bit 2 (ACKE0). For a slave device that has received an extension code, INTIIC0 occurs at the falling edge of the eighth clock.

However, if the address does not match after restart, INTIIC0 is generated at the falling edge of the 9th clock, but wait does not occur.

2. If the received address does not match the contents of slave address register 0 (SVA0) and extension code is not received, neither INTIIC0 nor a wait occurs.

Remark The numbers in the table indicate the number of the serial clock's clock signals. Interrupt requests and wait control are both synchronized with the falling edge of these clock signals.

(1) During address transmission/reception

- Slave device operation: Interrupt and wait timing are determined depending on the conditions described in Notes 1 and 2 above, regardless of the WTIM0 bit.
- Master device operation: Interrupt and wait timing occur at the falling edge of the ninth clock regardless of the WTIM0 bit.

(2) During data reception

- Master/slave device operation: Interrupt and wait timing are determined according to the WTIM0 bit.

(3) During data transmission

- Master/slave device operation: Interrupt and wait timing are determined according to the WTIM0 bit.

(4) Wait cancellation method

The four wait cancellation methods are as follows.

- Writing data to IIC shift register 0 (IIC0)
- Setting bit 5 (WRELO) of IIC control register 0 (IICCO) (canceling wait)
- Setting bit 1 (STT0) of IIC0 register (generating start condition)^{Note}
- Setting bit 0 (SPT0) of IIC0 register (generating stop condition)^{Note}

Note Master only.

When an 8-clock wait has been selected (WTIM0 = 0), the presence/absence of ACK generation must be determined prior to wait cancellation.

(5) Stop condition detection

INTIIC0 is generated when a stop condition is detected (only when SPIE0 = 1).

17.5.9 Address match detection method

In I²C bus mode, the master device can select a particular slave device by transmitting the corresponding slave address.

Address match can be detected automatically by hardware. An interrupt request (INTIIC0) occurs when a local address has been set to slave address register 0 (SVA0) and when the address set to SVA0 matches the slave address sent by the master device, or when an extension code has been received.

17.5.10 Error detection

In I²C bus mode, the status of the serial data bus (SDA0) during data transmission is captured by IIC shift register 0 (IIC0) of the transmitting device, so the IIC0 data prior to transmission can be compared with the transmitted IIC0 data to enable detection of transmission errors. A transmission error is judged as having occurred when the compared data values do not match.

17.5.11 Extension code

- (1) When the higher 4 bits of the receive address are either “0000” or “1111”, the extension code reception flag (EXC0) is set to 1 for extension code reception and an interrupt request (INTIIC0) is issued at the falling edge of the eighth clock. The local address stored in slave address register 0 (SVA0) is not affected.
- (2) If “11110××0” is set to SVA0 by a 10-bit address transfer and “11110××0” is transferred from the master device, the results are as follows. Note that INTIIC0 occurs at the falling edge of the eighth clock.
- Higher four bits of data match: EXC0 = 1
 - Seven bits of data match: COI0 = 1

Remark EXC0: Bit 5 of IIC status register 0 (IICS0)
COI0: Bit 4 of IIC status register 0 (IICS0)

- (3) Since the processing after the interrupt request occurs differs according to the data that follows the extension code, such processing is performed by software.
- If the extension code is received while a slave device is operating, then the slave device is participating in communication even if its address does not match.
- For example, after the extension code is received, if you do not wish to operate the target device as a slave device, set bit 6 (LREL0) of the IIC control register 0 (IICC0) to 1 to set the standby mode for the next communication operation.

Table 17-4. Extension Code Bit Definitions

Slave Address	R/W Bit	Description
0 0 0 0 0 0 0	0	General call address
0 0 0 0 0 0 0	1	Start byte
0 0 0 0 0 0 1	×	C-BUS address
0 0 0 0 0 1 0	×	Address that is reserved for different bus format
1 1 1 1 0 X X	×	10-bit slave address specification

17.5.12 Arbitration

When several master devices simultaneously generate a start condition (when STT0 is set to 1 before STD0 is set to 1), communication among the master devices is performed as the number of clocks are adjusted until the data differs. This kind of operation is called arbitration.

When one of the master devices loses in arbitration, an arbitration loss flag (ALD0) in IIC status register 0 (IICS0) is set (1) via the timing by which the arbitration loss occurred, and the SCL0 and SDA0 lines are both set to high impedance, which releases the bus.

The arbitration loss is detected based on the timing of the next interrupt request (the eighth or ninth clock, when a stop condition is detected, etc.) and the ALD0 = 1 setting that has been made by software.

For details of interrupt request timing, see **17.5.17 Timing of I²C interrupt request (INTIIC0) occurrence.**

Remark STD0: Bit 1 of IIC status register 0 (IICS0)
STT0: Bit 1 of IIC control register 0 (IICC0)

Figure 17-19. Arbitration Timing Example

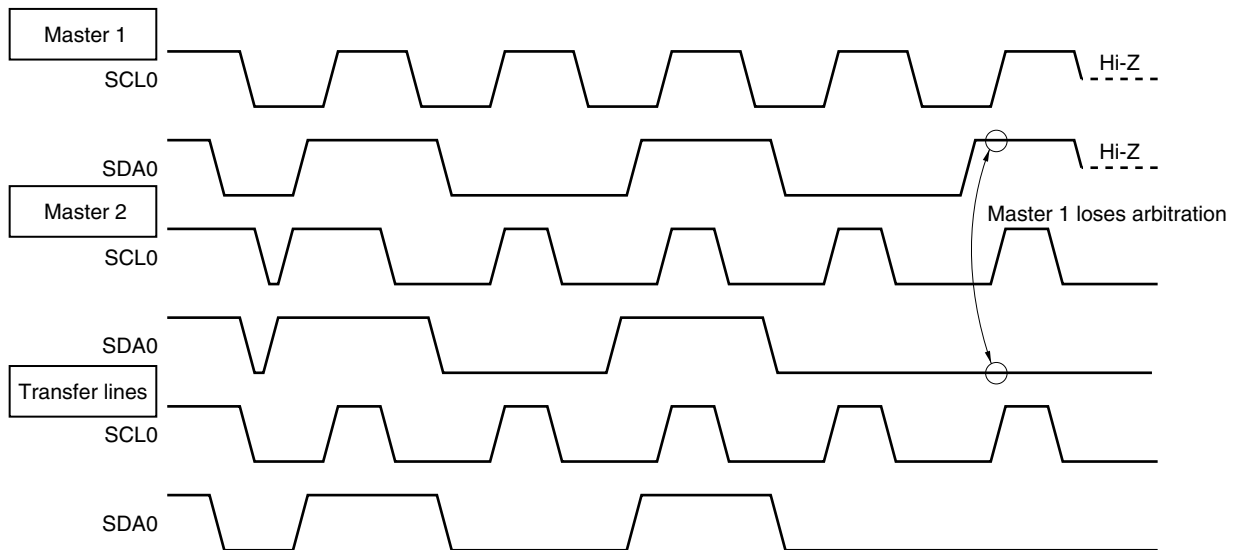

Table 17-5. Status During Arbitration and Interrupt Request Generation Timing

Status During Arbitration	Interrupt Request Generation Timing
During address transmission	At falling edge of eighth or ninth clock following byte transfer ^{Note 1}
Read/write data after address transmission	
During extension code transmission	
Read/write data after extension code transmission	
During data transmission	
During $\overline{\text{ACK}}$ transfer period after data transmission	
When restart condition is detected during data transfer	
When stop condition is detected during data transfer	When stop condition is generated (when SPIE0 = 1) ^{Note 2}
When data is at low level while attempting to generate a restart condition	At falling edge of eighth or ninth clock following byte transfer ^{Note 1}
When stop condition is detected while attempting to generate a restart condition	When stop condition is generated (when SPIE0 = 1) ^{Note 2}
When data is at low level while attempting to generate a stop condition	At falling edge of eighth or ninth clock following byte transfer ^{Note 1}
When SCL0 is at low level while attempting to generate a restart condition	

Notes 1. When WTIM0 (bit 3 of IIC control register 0 (IICC0)) = 1, an interrupt request occurs at the falling edge of the ninth clock. When WTIM0 = 0 and the extension code's slave address is received, an interrupt request occurs at the falling edge of the eighth clock.

2. When there is a chance that arbitration will occur, set SPIE0 = 1 for master device operation.

Remark SPIE0: Bit 4 of IIC control register 0 (IICC0)

17.5.13 Wakeup function

The I²C bus slave function is a function that generates an interrupt request signal (INTIIC0) when a local address and extension code have been received.

This function makes processing more efficient by preventing unnecessary INTIIC0 signal from occurring when addresses do not match.

When a start condition is detected, wakeup standby mode is set. This wakeup standby mode is in effect while addresses are transmitted due to the possibility that an arbitration loss may change the master device (which has generated a start condition) to a slave device.

However, when a stop condition is detected, bit 4 (SPIE0) of IIC control register 0 (IICC0) is set regardless of the wakeup function, and this determines whether interrupt requests are enabled or disabled.

17.5.14 Communication reservation

(1) When communication reservation function is enabled (bit 0 (IICRSV) of IIC flag register 0 (IICF0) = 0)

To start master device communications when not currently using a bus, a communication reservation can be made to enable transmission of a start condition when the bus is released. There are two modes under which the bus is not used.

- When arbitration results in neither master nor slave operation
- When an extension code is received and slave operation is disabled (\overline{ACK} is not returned and the bus was released when bit 6 (LREL0) of IIC control register 0 (IICC0) was set to 1).

If bit 1 (STT0) of IICC0 is set to 1 while the bus is not used (after a stop condition is detected), a start condition is automatically generated and wait state is set.

If an address is written to IIC shift register 0 (IIC0) after bit 4 (SPIE0) of IICC0 was set to 1, and it was detected by generation of an interrupt request signal (INTIIC0) that the bus was released (detection of the stop condition), then the device automatically starts communication as the master. Data written to IIC0 before the stop condition is detected is invalid.

When STT0 has been set to 1, the operation mode (as start condition or as communication reservation) is determined according to the bus status.

- If the bus has been releaseda start condition is generated
- If the bus has not been released (standby mode)communication reservation

Check whether the communication reservation operates or not by using MSTS0 (bit 7 of IIC status register 0 (IICS0)) after STT0 is set to 1 and the wait time elapses.

The wait periods, which should be set via software, are listed in Table 17-6.

★

Table 17-6. Wait Periods

CLX0	SMC0	CL01	CL00	Wait Period
0	0	0	0	46 clocks
0	0	0	1	86 clocks
0	0	1	0	172 clocks
0	0	1	1	34 clocks
0	1	0	0	30 clocks
0	1	0	1	30 clocks
0	1	1	0	60 clocks
0	1	1	1	12 clocks
1	1	0	0	18 clocks
1	1	0	1	18 clocks
1	1	1	0	36 clocks

Figure 17-20 shows the communication reservation timing.

★

Figure 17-20. Communication Reservation Timing

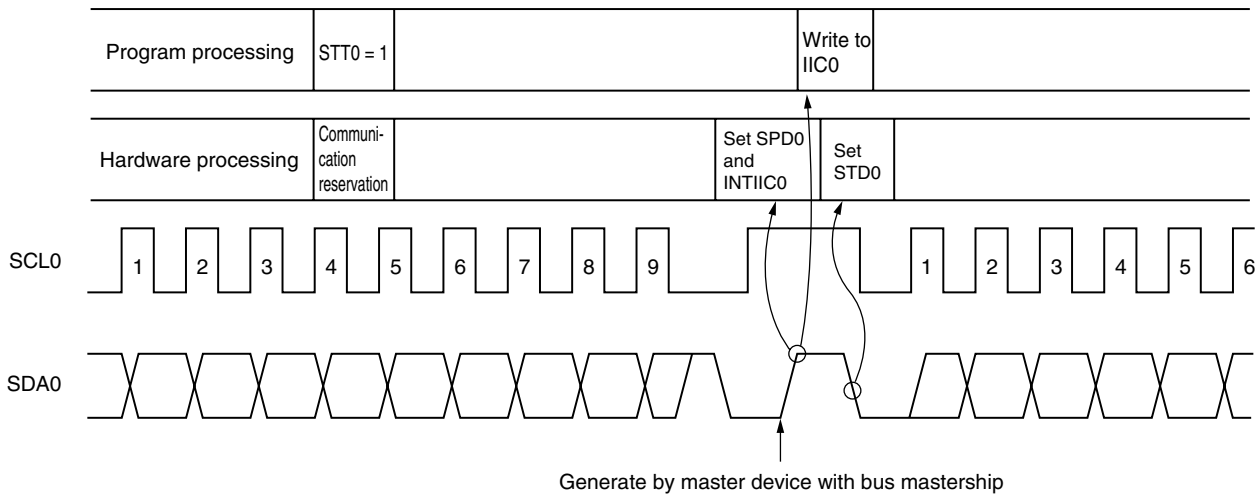

Remark IIC0: IIC shift register 0
 STT0: Bit 1 of IIC control register 0 (IICC0)
 STD0: Bit 1 of IIC status register 0 (IICS0)
 SPD0: Bit 0 of IIC status register 0 (IICS0)

Communication reservations are accepted via the following timing. After bit 1 (STD0) of IIC status register 0 (IICS0) is set to 1, a communication reservation can be made by setting bit 1 (STT0) of IIC control register 0 (IICC0) to 1 before a stop condition is detected.

Figure 17-21. Timing for Accepting Communication Reservations

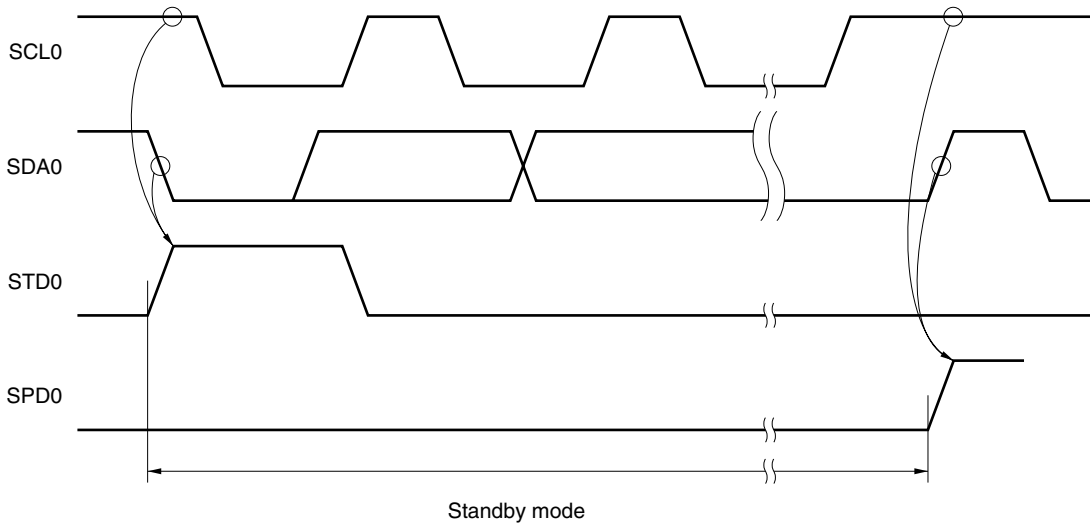
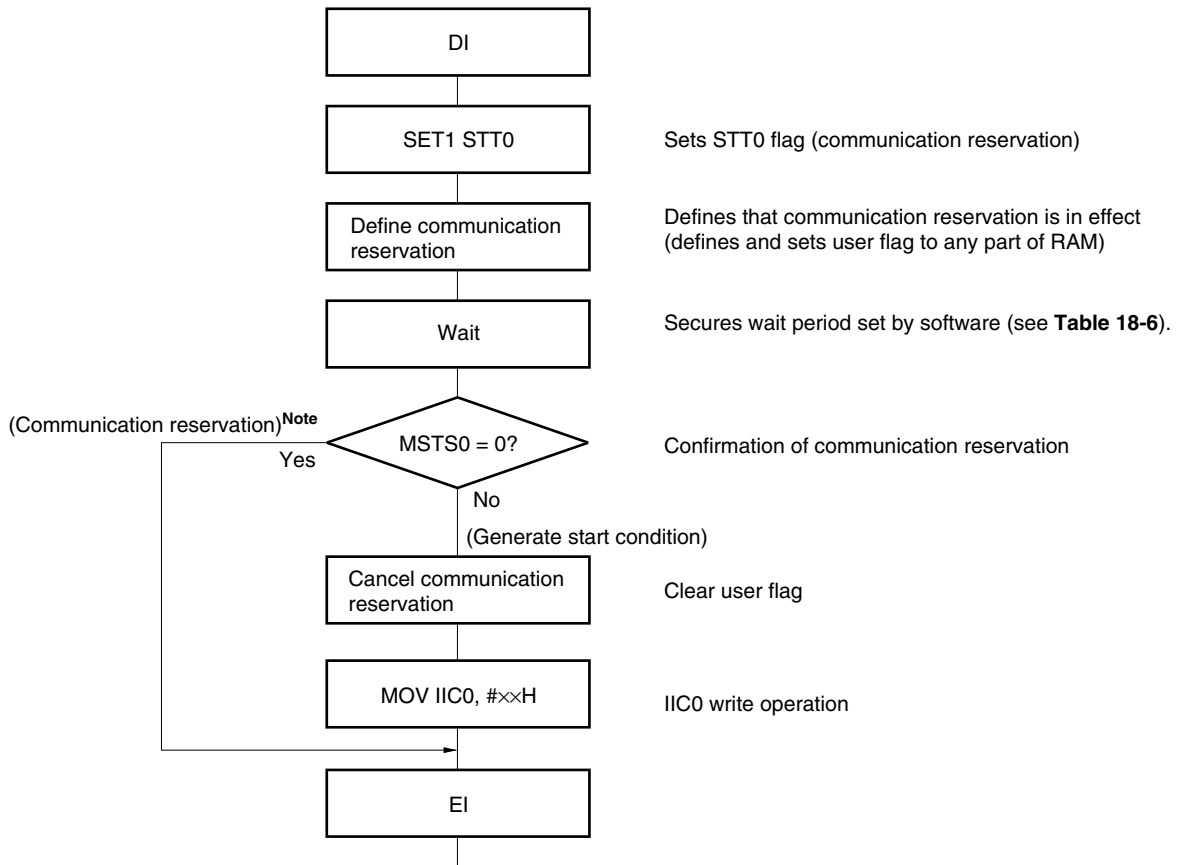

Figure 17-22 shows the communication reservation protocol.

Figure 17-22. Communication Reservation Protocol



Note The communication reservation operation executes a write to IIC shift register 0 (IIC0) when a stop condition interrupt request occurs.

Remark STT0: Bit 1 of IIC control register 0 (IICC0)
 MSTS0: Bit 7 of IIC status register 0 (IICS0)
 IIC0: IIC shift register 0

(2) When communication reservation function is disabled (bit 0 (IICRSV) of IIC flag register 0 (IICF0) = 1)

When bit 1 (STT0) of IIC control register 0 (IICC0) is set to 1 when the bus is not used in a communication during bus communication, this request is rejected and a start condition is not generated. The following two statuses are included in the status where bus is not used.

- When arbitration results in neither master nor slave operation
- When an extension code is received and slave operation is disabled (\overline{ACK} is not returned and the bus was released when bit 6 (LREL0) of IICC0 was set to 1)

To confirm whether the start condition was generated or request was rejected, check STCF (bit 7 of IICF0). The time shown in Table 17-7 is required until STCF is set to 1 after setting STT0 = 1. Therefore, secure the time by software.

★

Table 17-7. Wait Periods

CL01	CL00	Wait Period
0	0	6 clocks
0	1	6 clocks
1	0	12 clocks
1	1	3 clocks

17.5.15 Other cautions

(1) When STCEN (bit 1 of IIC flag register 0 (IICF0)) = 0

Immediately after I²C operation is enabled (IICE0 = 1), the bus communication status (IICBSY (bit 6 of IICF0) = 1) is recognized regardless of the actual bus status. When changing from a mode in which no stop condition has been detected to a master device communication mode, first generate a stop condition to release the bus, then perform master device communication.

When using multiple masters, it is not possible to perform master device communication when the bus has not been released (when a stop condition has not been detected).

Use the following sequence for generating a stop condition.

- <1> Set IIC clock selection register 0 (IICCL0).
- <2> Set bit 7 (IICE0) of IIC control register 0 (IICC0) to 1.
- <3> Set bit 0 (SPT0) of IICC0 to 1.

(2) When STCEN = 1

Immediately after I²C operation is enabled (IICE0 = 1), the bus released status (IICBSY = 0) is recognized regardless of the actual bus status. To generate the first start condition (STT0 (bit 1 of IIC control register 0 (IICC0)) = 1), it is necessary to confirm that the bus has been released, so as to not disturb other communications.

(3) If other I²C communications are already in progress

If I²C operation is enabled and the device participates in communication already in progress when the SDA0 pin is low and the SCL0 pin is high, the macro of I²C recognizes that the SDA0 pin has gone low (detects a start condition). If the value on the bus at this time can be recognized as an extension code, \overline{ACK} is returned, but this interferes with other I²C communications. To avoid this, start I²C in the following sequence.

- <1> Clear bit 4 (SPIE0) of IICC0 to 0 to disable generation of an interrupt request signal (INTIIC0) when the stop condition is detected.
- <2> Set bit 7 (IICE0) of IICC0 to 1 to enable the operation of I²C.
- <3> Wait for detection of the start condition.
- <4> Set bit 6 (LREL0) of IICC0 to 1 before \overline{ACK} is returned (4 to 80 clocks after setting IICE0 to 1), to forcibly disable detection.

- ★ (4) Determine the transfer clock frequency by using SMC0, CL01, CL00 (bits 3, 1, and 0 of IICL0), and CLX0 (bit 0 of IICX0) before enabling the operation (IICE0 = 1). To change the transfer clock frequency, clear IICE0 to 0 once.

- ★ (5) Setting STT0 and SPT0 (bits 1 and 0 of IICC0) again after they are set and before they are cleared to 0 is prohibited.

- ★ (6) When transmission is reserved, set SPIE0 (bit 4 of IICL0) to 1 so that an interrupt request is generated when the stop condition is detected. Transfer is started when communication data is written to IIC0 after the interrupt request is generated. Unless the interrupt is generated when the stop condition is detected, the device stops in the wait state because the interrupt request is not generated when communication is started. However, it is not necessary to set SPIE0 to 1 when MSTS0 (bit 7 of IICS0) is detected by software.

17.5.16 Communication operations

★ (1) Master operation (single-master system)

Figure 17-23. Master Operation Flowchart (Single-Master System)

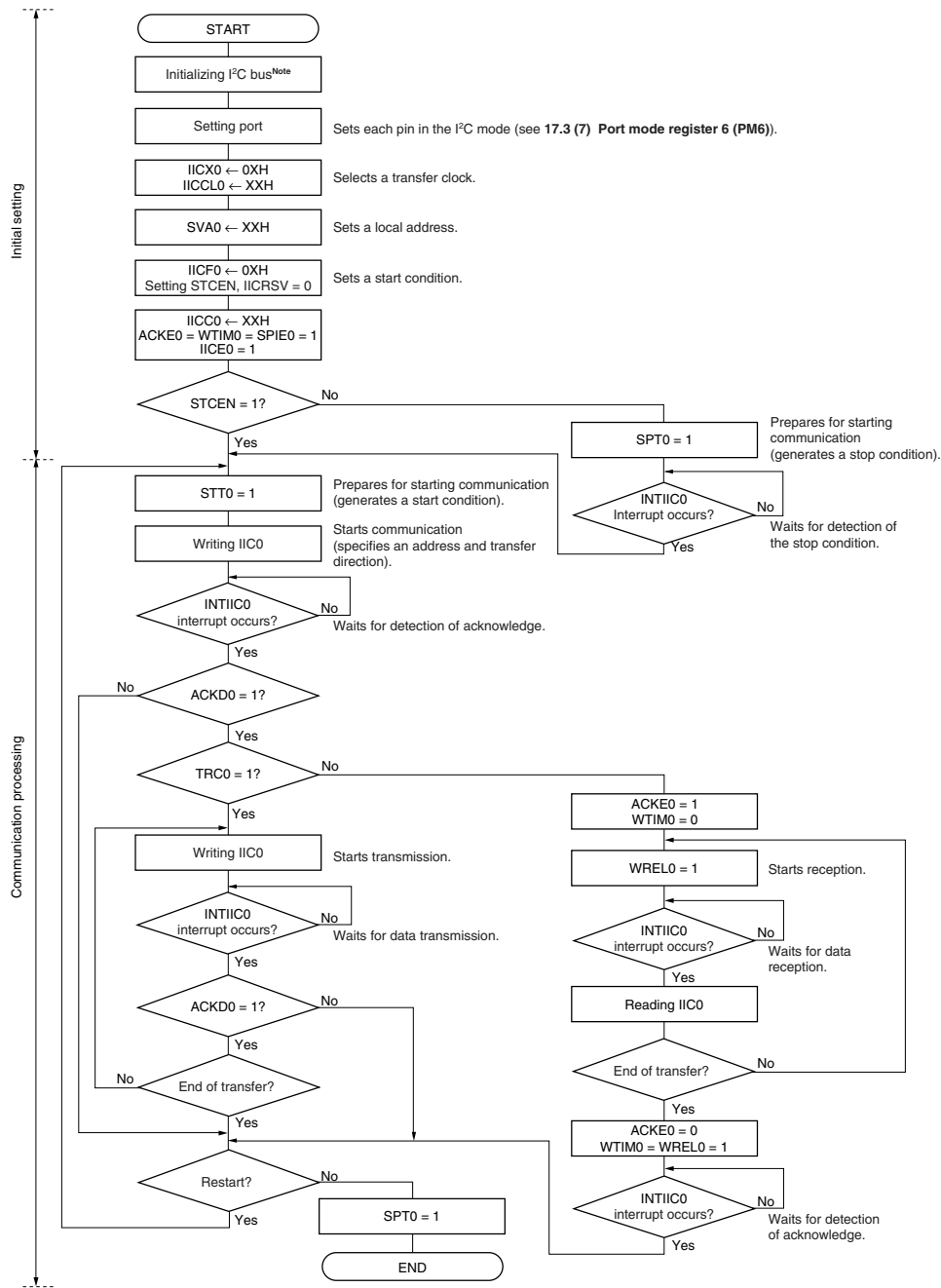

Note Release (SCL0 and SDA0 pins = high level) the I²C bus in conformance with the specifications of the product that is communicating. If EEPROM is outputting a low level to the SDA0 pin, for example, set the SCL0 pin in the output port mode, and output a clock pulse from the output port until the SDA0 pin is constantly at high level.

Remark Conform to the specifications of the product that is communicating, with respect to the transmission and reception formats.

★ (2) Master operation (multi-master system)

Figure 17-24. Master Operation Flowchart (Multi-Master System) (1/3)

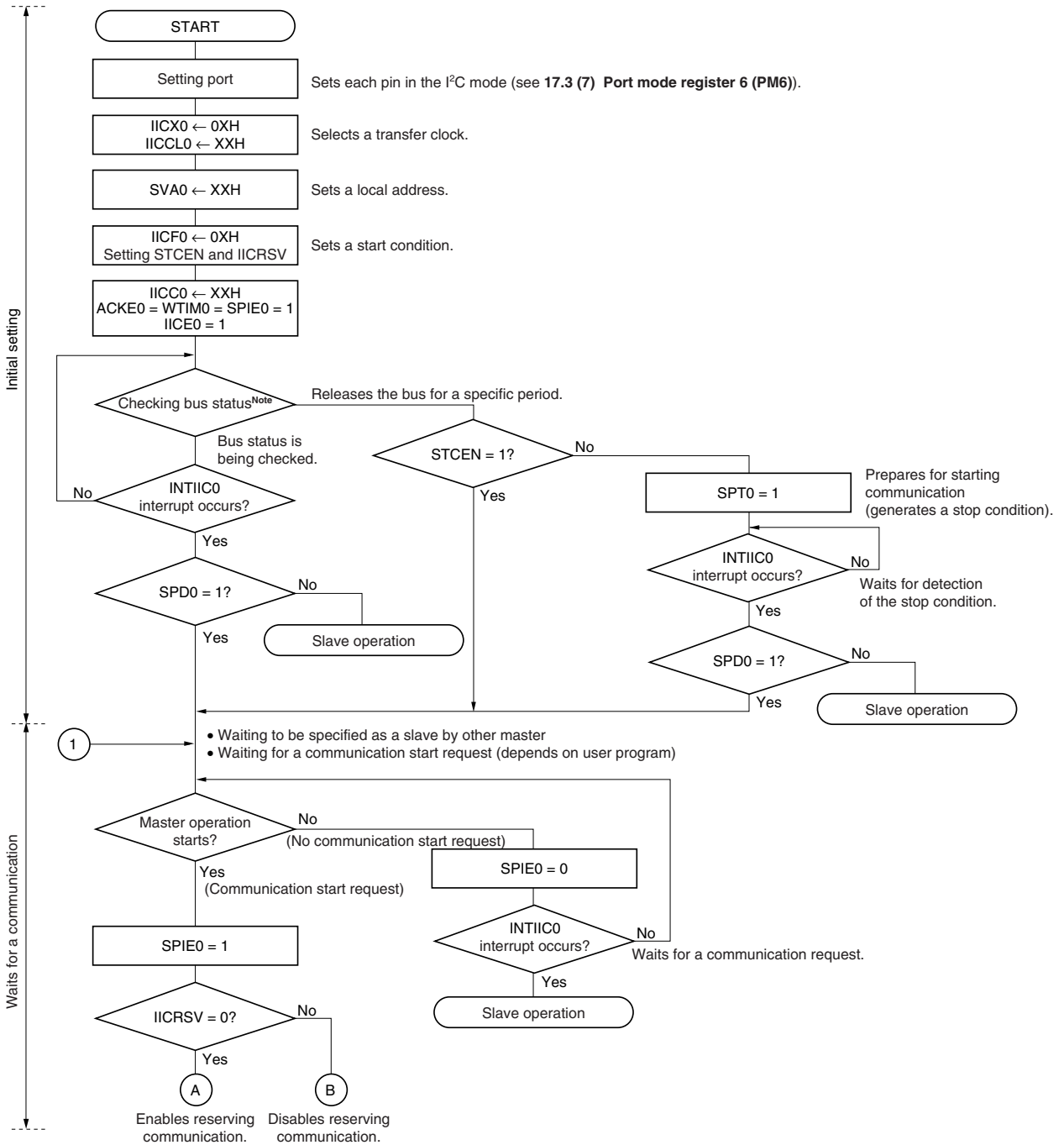

Note Confirm that the bus is released (CLD0 bit = 1, DAD0 bit = 1) for a specific period (for example, for a period of one frame). If the SDA0 pin is constantly at low level, decide whether to release the I²C bus (SCL0 and SDA0 pins = high level) in conformance with the specifications of the product that is communicating.

Figure 17-24. Master Operation Flowchart (Multi-Master System) (2/3)

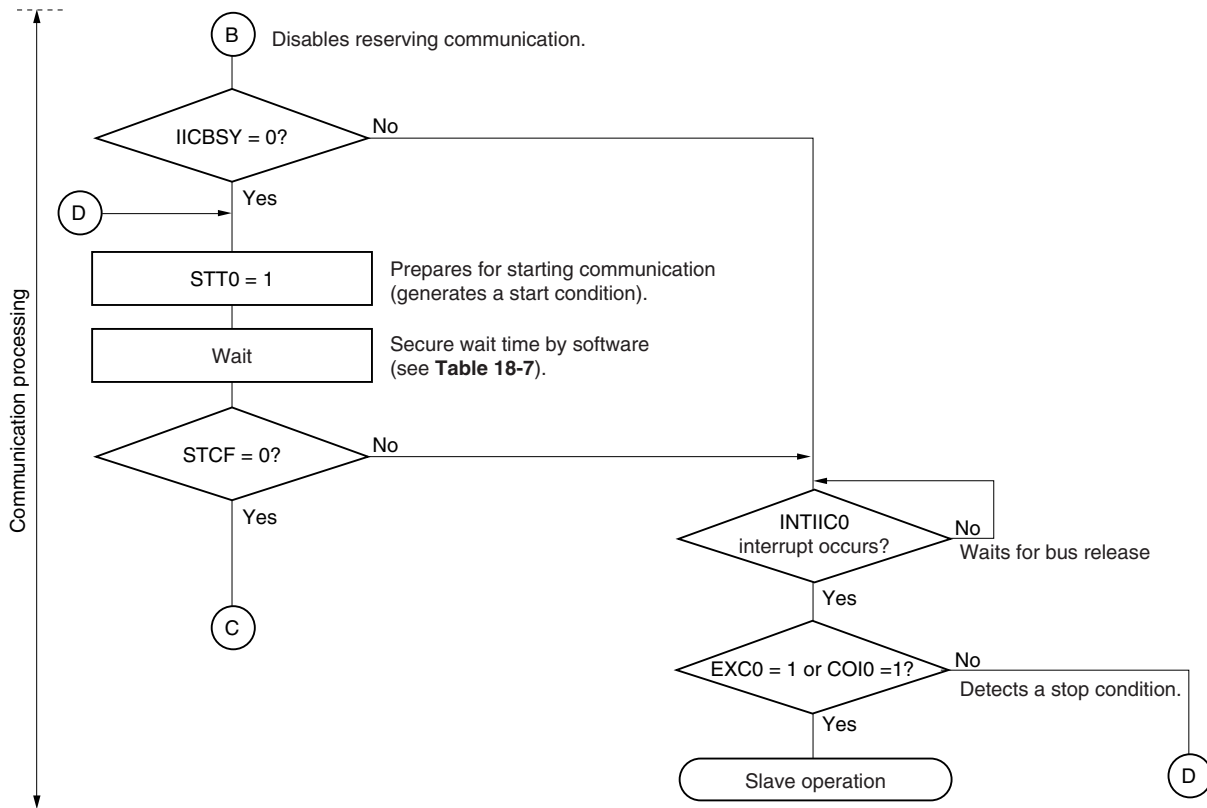
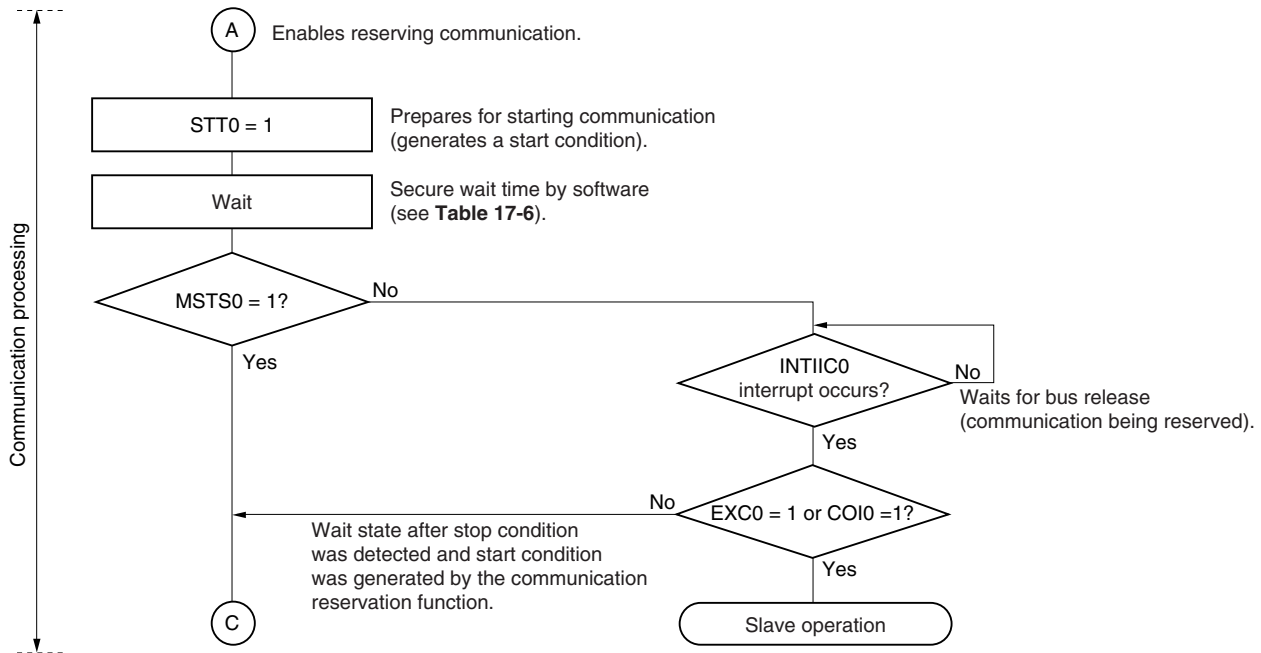
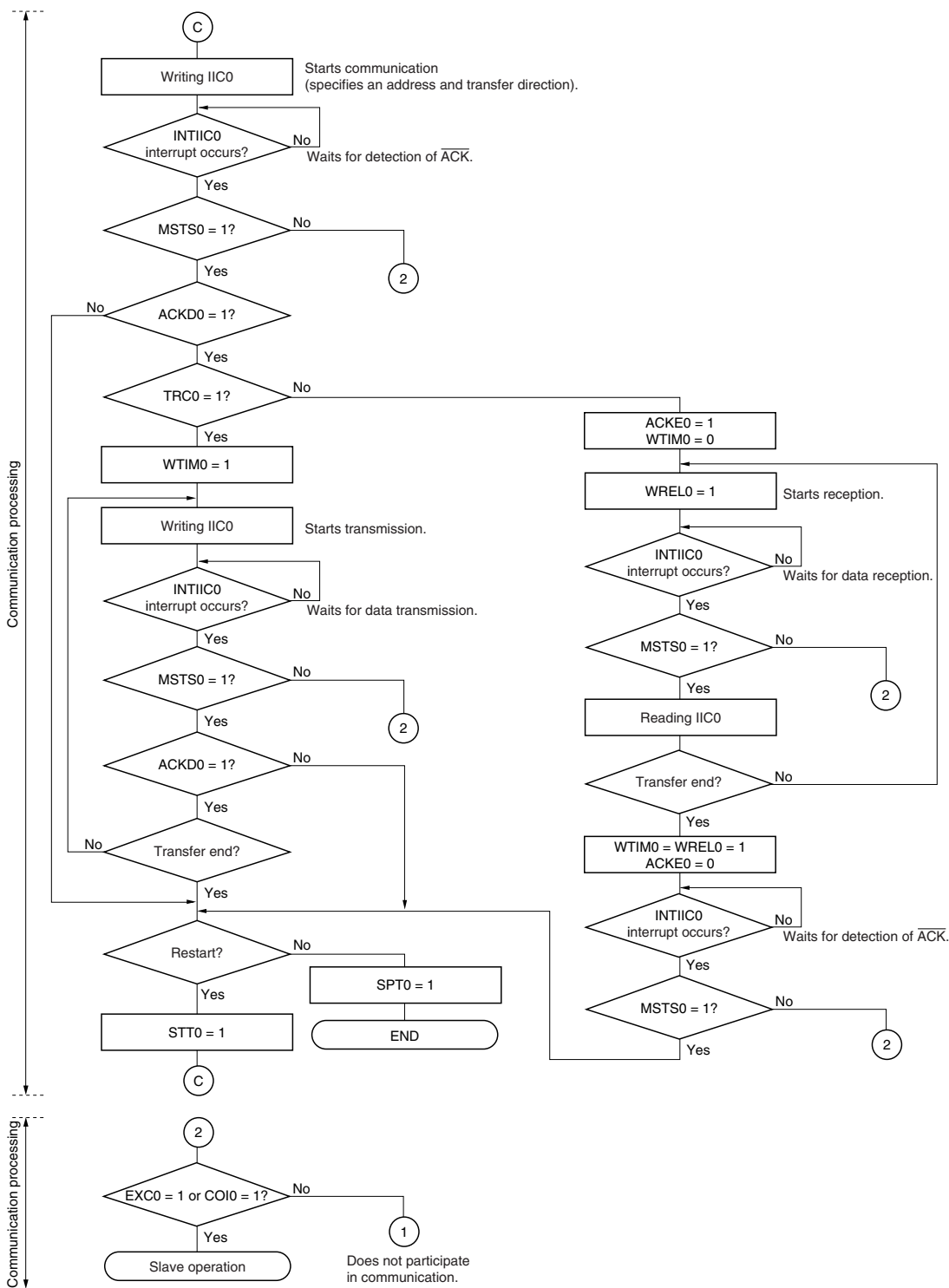

Figure 17-24. Master Operation Flowchart (Multi-Master System) (3/3)



- Remarks**
1. Conform to the specifications of the product that is communicating, with respect to the transmission and reception formats.
 2. To use the device as a master in a multi-master system, read the MSTS0 bit each time interrupt INTIIC0 has occurred to check the arbitration result.
 3. To use the device as a slave in a multi-master system, check the status by using the IICS0 and IICF0 registers each time interrupt INTIIC0 has occurred, and determine the processing to be performed next.

(3) Slave operation

The processing procedure of the slave operation is as follows.

Basically, the slave operation is event-driven. Therefore, processing by the INTIIC0 interrupt (processing that must substantially change the operation status such as detection of a stop condition during communication) is necessary.

In the following explanation, it is assumed that the extension code is not supported for data communication. It is also assumed that the INTIIC0 interrupt servicing only performs status transition processing, and that actual data communication is performed by the main processing.

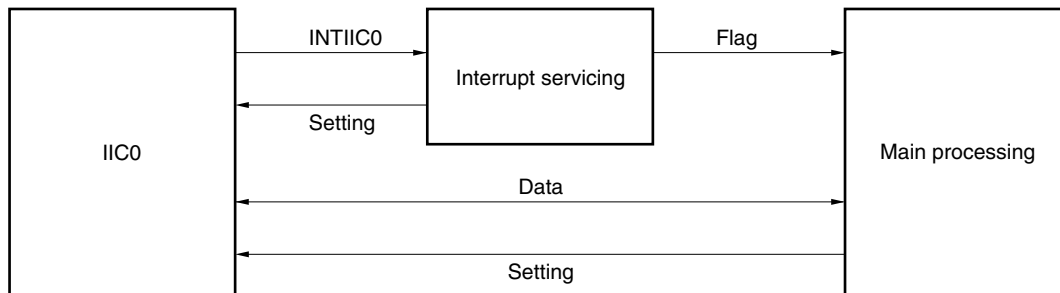

Therefore, data communication processing is performed by preparing the following three flags and passing them to the main processing instead of INTIIC0.

<1> Communication mode flag

This flag indicates the following two communication statuses.

- Clear mode: Status in which data communication is not performed
- Communication mode: Status in which data communication is performed (from valid address detection to stop condition detection, no detection of $\overline{\text{ACK}}$ from master, address mismatch)

<2> Ready flag

This flag indicates that data communication is enabled. Its function is the same as the INTIIC0 interrupt for ordinary data communication. This flag is set by interrupt servicing and cleared by the main processing. Clear this flag by interrupt servicing when communication is started. However, the ready flag is not set by interrupt servicing when the first data is transmitted. Therefore, the first data is transmitted without the flag being cleared (an address match is interpreted as a request for the next data).

<3> Communication direction flag

This flag indicates the direction of communication. Its value is the same as TRC0.

The main processing of the slave operation is explained next.

Start serial interface IIC0 and wait until communication is enabled. When communication is enabled, execute communication by using the communication mode flag and ready flag (processing of the stop condition and start condition is performed by an interrupt. Here, check the status by using the flags).

The transmission operation is repeated until the master no longer returns $\overline{\text{ACK}}$. If $\overline{\text{ACK}}$ is not returned from the master, communication is completed.

For reception, the necessary amount of data is received. When communication is completed, $\overline{\text{ACK}}$ is not returned as the next data. After that, the master generates a stop condition or restart condition. Exit from the communication status occurs in this way.

★

Figure 17-25. Slave Operation Flowchart (1)

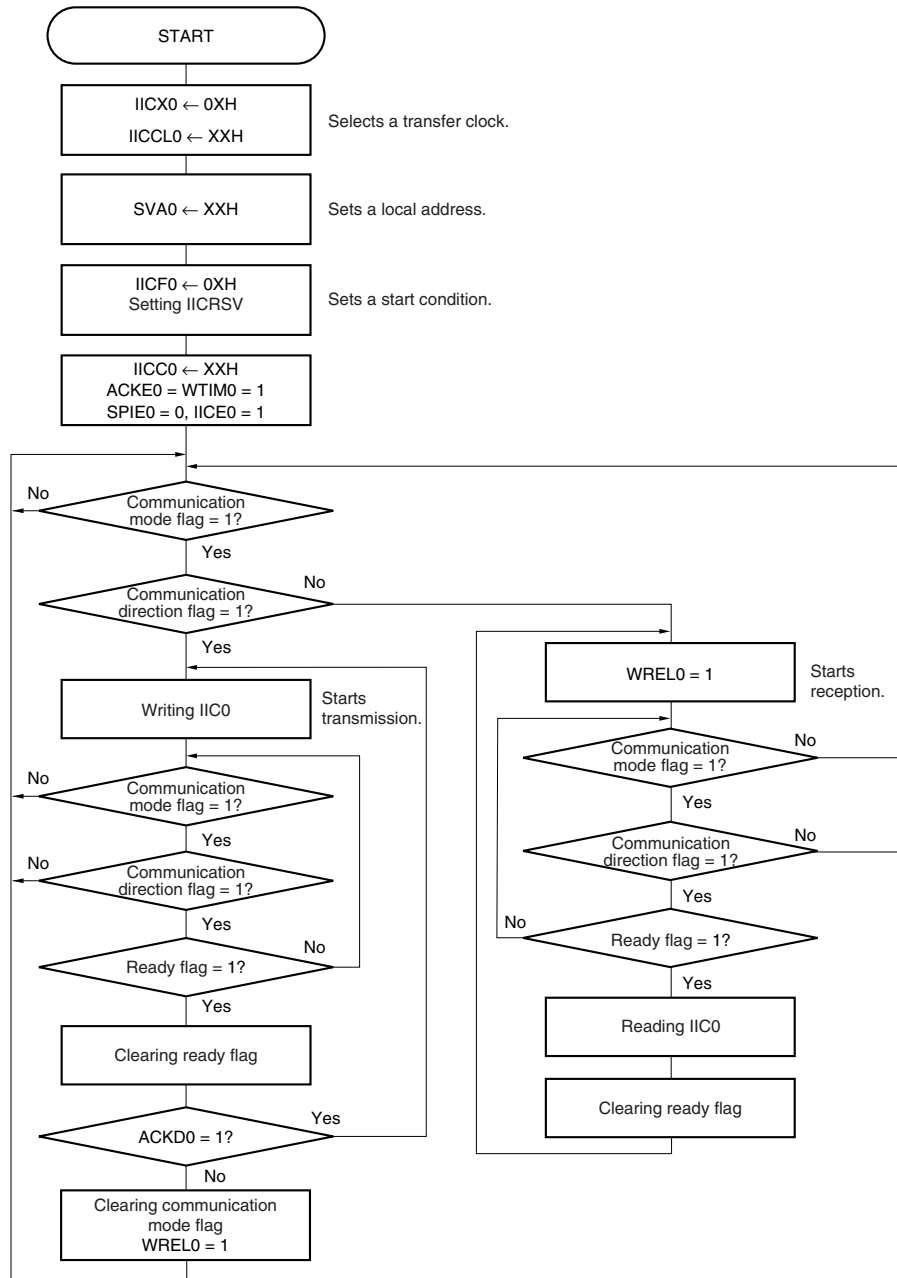

Remark Conform to the specifications of the product that is in communication, regarding the transmission and reception formats.

An example of the processing procedure of the slave with the INTIIC0 interrupt is explained below (processing is performed assuming that no extension code is used). The INTIIC0 interrupt checks the status, and the following operations are performed.

- <1> Communication is stopped if the stop condition is issued.
- <2> If the start condition is issued, the address is checked and communication is completed if the address does not match. If the address matches, the communication mode is set, wait is cancelled, and processing returns from the interrupt (the ready flag is cleared).
- <3> For data transmit/receive, only the ready flag is set. Processing returns from the interrupt with the I²C bus remaining in the wait state.

Remark <1> to <3> above correspond to <1> to <3> in **Figure 17-26 Slave Operation Flowchart (2)**.

★

Figure 17-26. Slave Operation Flowchart (2)

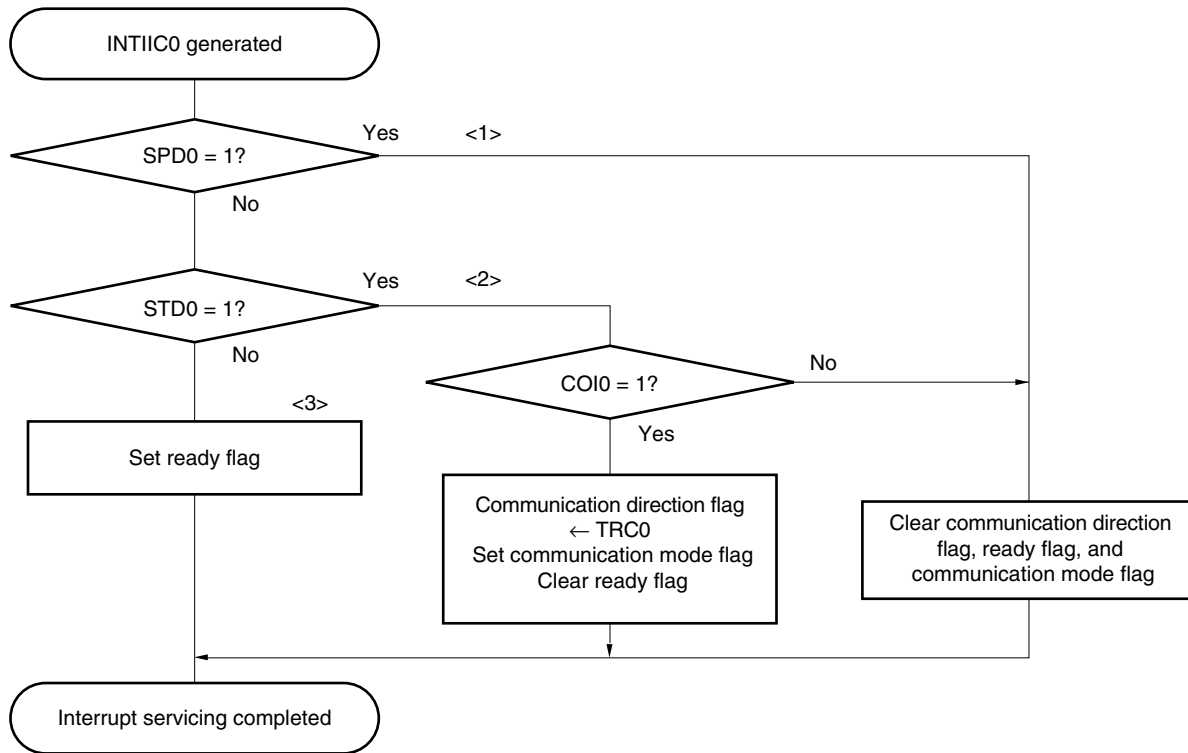

17.5.17 Timing of I²C interrupt request (INTIIC0) occurrence

The timing of transmitting or receiving data and generation of interrupt request signal INTIIC0, and the value of the IICS0 register when the INTIIC0 signal is generated are shown below.

Remark ST: Start condition
AD6 to AD0: Address

(1) Master device operation

(a) Start ~ Address ~ Data ~ Data ~ Stop (transmission/reception)

(i) When WTIM0 = 0

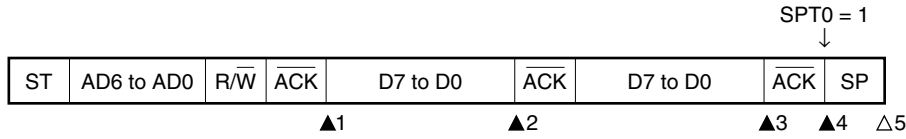

- ▲1: IICS0 = 1000x110B
- ▲2: IICS0 = 1000x000B
- ▲3: IICS0 = 1000x000B (Sets WTIM0 to 1)^{Note}
- ▲4: IICS0 = 1000x000B (Sets SPT0 to 1)^{Note}
- △5: IICS0 = 00000001B

★ **Note** To generate a stop condition, set WTIM0 to 1 and change the timing for generating the INTIIC0 interrupt request signal.

Remark ▲: Always generated
 △: Generated only when SPIE0 = 1
 x: Don't care

★ (ii) When WTIM0 = 1

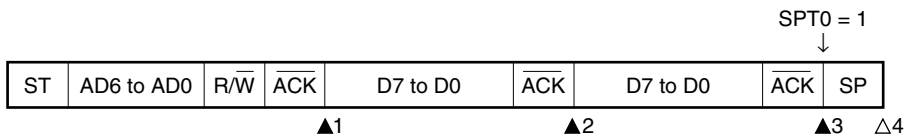

- ▲1: IICS0 = 1000x110B
- ▲2: IICS0 = 1000x100B
- ▲3: IICS0 = 1000x000B (Sets SPT0 to 1)
- △4: IICS0 = 00000001B

Remark ▲: Always generated
 △: Generated only when SPIE0 = 1
 x: Don't care

(b) Start ~ Address ~ Data ~ Start ~ Address ~ Data ~ Stop (restart)

(i) When WTIM0 = 0

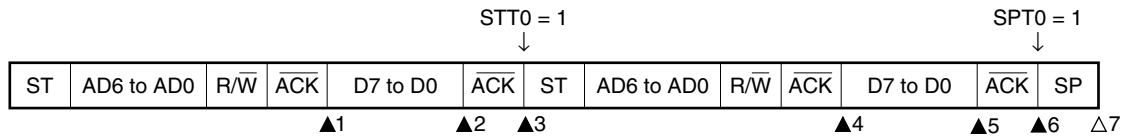

- ▲1: IICS0 = 1000x110B
- ▲2: IICS0 = 1000x000B (Sets WTIM0 to 1)^{Note 1}
- ▲3: IICS0 = 1000xx00B (Clears WTIM0 to 0^{Note 2}, sets STT0 to 1)
- ▲4: IICS0 = 1000x110B
- ▲5: IICS0 = 1000x000B (Sets WTIM0 to 1)^{Note 3}
- ▲6: IICS0 = 1000xx00B (Sets SPT0 to 1)
- Δ7: IICS0 = 00000001B

- ★ **Notes 1.** To generate a start condition, set WTIM0 to 1 and change the timing for generating the INTIIC0 interrupt request signal.
- ★ **2.** Clear WTIM0 to 0 to restore the original setting.
- ★ **3.** To generate a stop condition, set WTIM0 to 1 and change the timing for generating the INTIIC0 interrupt request signal.

Remark ▲: Always generated
 Δ: Generated only when SPIE0 = 1
 x: Don't care

(ii) When WTIM0 = 1

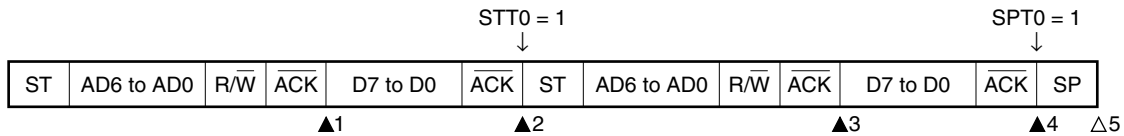

- ▲1: IICS0 = 1000x110B
- ▲2: IICS0 = 1000xx00B (Sets STT0 to 1)
- ▲3: IICS0 = 1000x110B
- ▲4: IICS0 = 1000xx00B (Sets SPT0 to 1)
- Δ5: IICS0 = 00000001B

Remark ▲: Always generated
 Δ: Generated only when SPIE0 = 1
 x: Don't care

(c) Start ~ Code ~ Data ~ Data ~ Stop (extension code transmission)

(i) When WTIM0 = 0

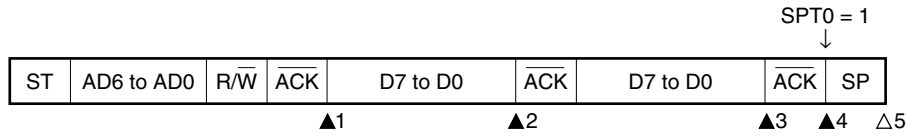

- ▲1: IICS0 = 1010x110B
- ▲2: IICS0 = 1010x000B
- ▲3: IICS0 = 1010x000B (Sets WTIM0 to 1)^{Note}
- ▲4: IICS0 = 1010xx00B (Sets SPT0 to 1)
- Δ5: IICS0 = 00000001B

★ **Note** To generate a stop condition, set WTIM0 to 1 and change the timing for generating the INTIIC0 interrupt request signal.

Remark ▲: Always generated
 Δ: Generated only when SPIE0 = 1
 x: Don't care

(ii) When WTIM0 = 1

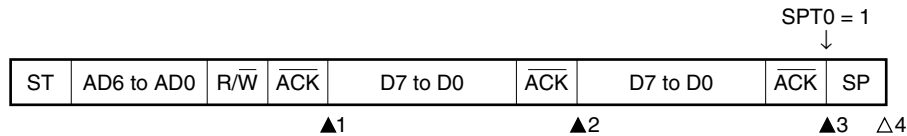

- ▲1: IICS0 = 1010x110B
- ▲2: IICS0 = 1010x100B
- ▲3: IICS0 = 1010xx00B (Sets SPT0 to 1)
- Δ4: IICS0 = 00001001B

Remark ▲: Always generated
 Δ: Generated only when SPIE0 = 1
 x: Don't care

(2) Slave device operation (slave address data reception)

(a) Start ~ Address ~ Data ~ Data ~ Stop

(i) When $WTIM0 = 0$

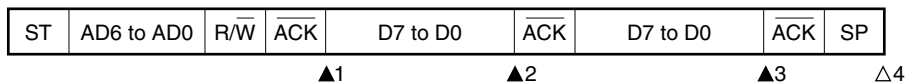

▲1: IICS0 = 0001×110B

▲2: IICS0 = 0001×000B

▲3: IICS0 = 0001×000B

△4: IICS0 = 00000001B

Remark ▲: Always generated
 △: Generated only when SPIE0 = 1
 x: Don't care

(ii) When $WTIM0 = 1$

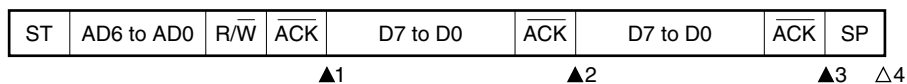

▲1: IICS0 = 0001×110B

▲2: IICS0 = 0001×100B

▲3: IICS0 = 0001××00B

△4: IICS0 = 00000001B

Remark ▲: Always generated
 △: Generated only when SPIE0 = 1
 x: Don't care

(b) Start ~ Address ~ Data ~ Start ~ Address ~ Data ~ Stop

(i) When WTIM0 = 0 (after restart, matches with SVA0)

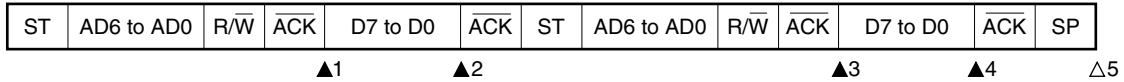

▲1: IICS0 = 0001x110B

▲2: IICS0 = 0001x000B

▲3: IICS0 = 0001x110B

▲4: IICS0 = 0001x000B

△5: IICS0 = 00000001B

Remark ▲: Always generated
 △: Generated only when SPIE0 = 1
 x: Don't care

(ii) When WTIM0 = 1 (after restart, matches with SVA0)

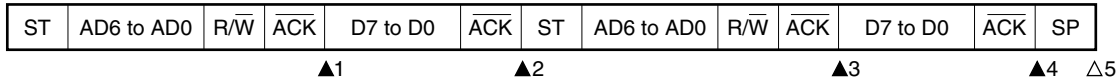

▲1: IICS0 = 0001x110B

▲2: IICS0 = 0001xx00B

▲3: IICS0 = 0001x110B

▲4: IICS0 = 0001xx00B

△5: IICS0 = 00000001B

Remark ▲: Always generated
 △: Generated only when SPIE0 = 1
 x: Don't care

(c) Start ~ Address ~ Data ~ Start ~ Code ~ Data ~ Stop

(i) When WTIM0 = 0 (after restart, does not match address (= extension code))

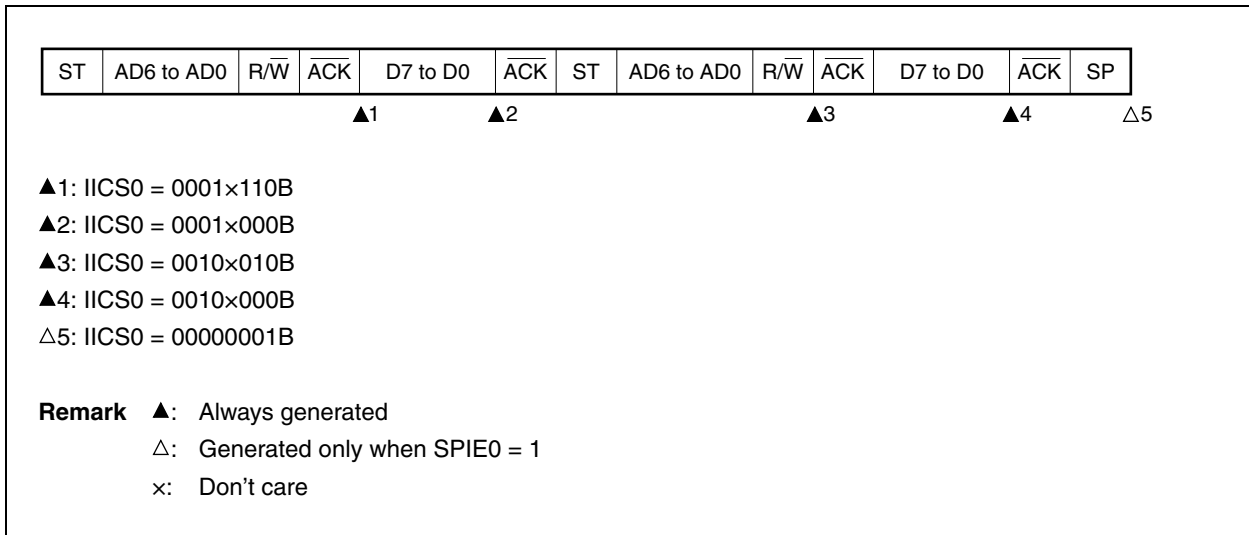

(ii) When WTIM0 = 1 (after restart, does not match address (= extension code))

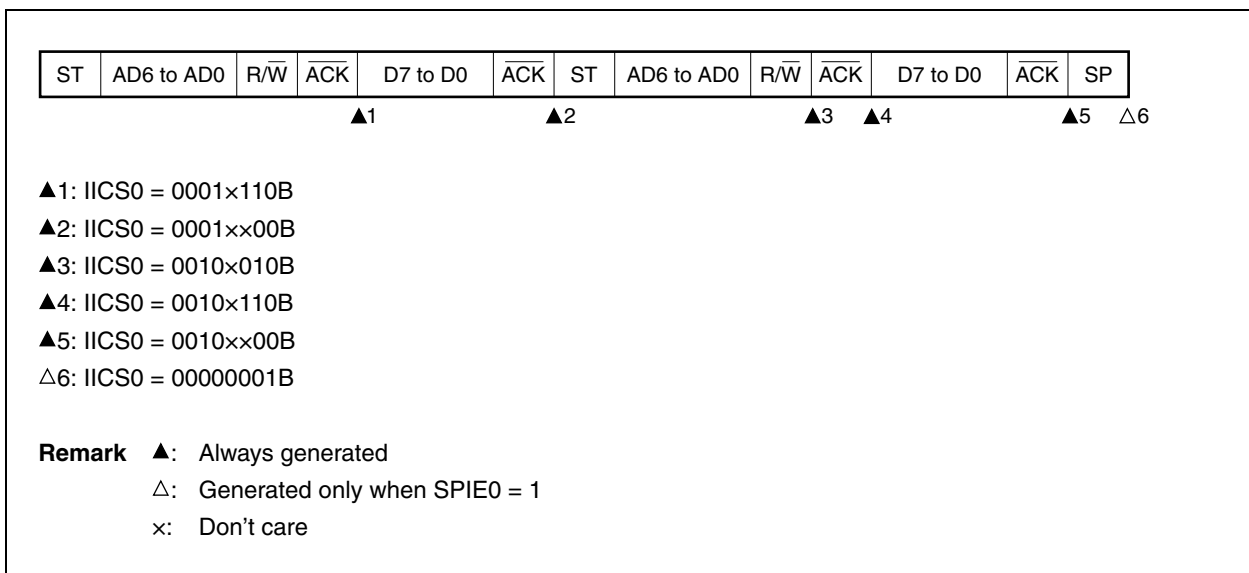

(d) Start ~ Address ~ Data ~ Start ~ Address ~ Data ~ Stop

(i) When WTIM0 = 0 (after restart, does not match address (= not extension code))

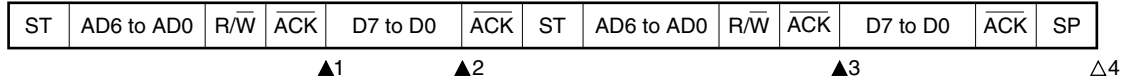

▲1: IICS0 = 0001x110B

▲2: IICS0 = 0001x000B

▲3: IICS0 = 00000110B

△4: IICS0 = 00000001B

Remark ▲: Always generated

△: Generated only when SPIE0 = 1

x: Don't care

(ii) When WTIM0 = 1 (after restart, does not match address (= not extension code))

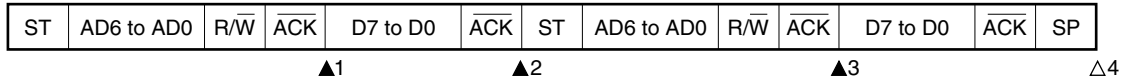

▲1: IICS0 = 0001x110B

▲2: IICS0 = 0001xx00B

▲3: IICS0 = 00000110B

△4: IICS0 = 00000001B

Remark ▲: Always generated

△: Generated only when SPIE0 = 1

x: Don't care

(3) Slave device operation (when receiving extension code)

The device is always participating in communication when it receives an extension code.

(a) Start ~ Code ~ Data ~ Data ~ Stop

(i) When WTIM0 = 0

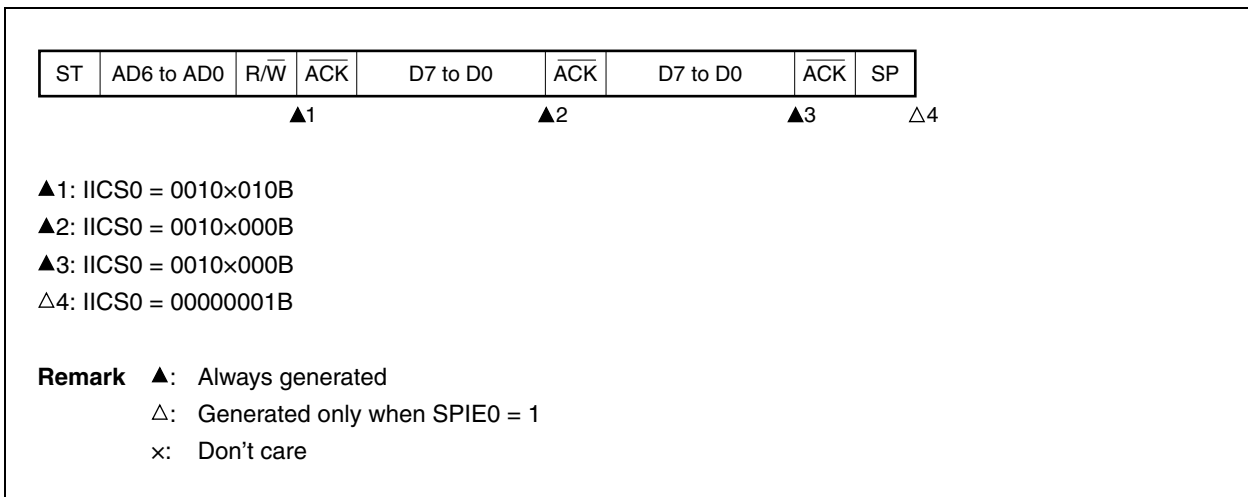

(ii) When WTIM0 = 1

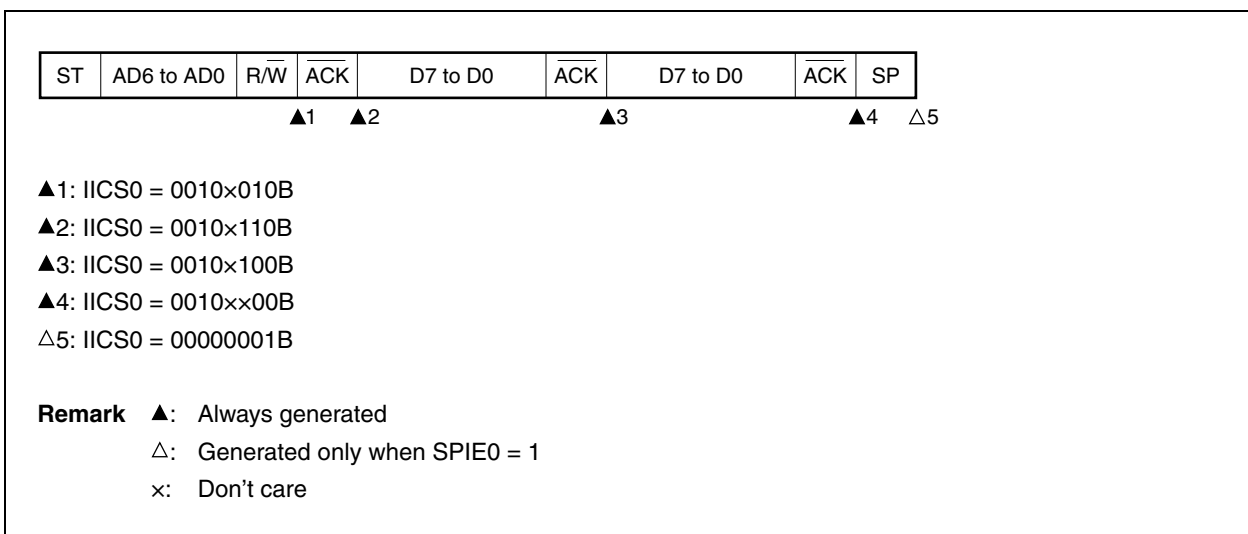

(b) Start ~ Code ~ Data ~ Start ~ Address ~ Data ~ Stop

(i) When WTIM0 = 0 (after restart, matches SVA0)

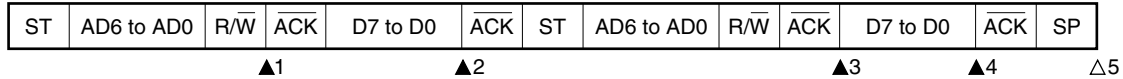

- ▲1: IICS0 = 0010x010B
- ▲2: IICS0 = 0010x000B
- ▲3: IICS0 = 0001x110B
- ▲4: IICS0 = 0001x000B
- △5: IICS0 = 00000001B

Remark ▲: Always generated
 △: Generated only when SPIE0 = 1
 x: Don't care

(ii) When WTIM0 = 1 (after restart, matches SVA0)

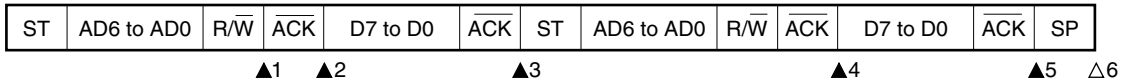

- ▲1: IICS0 = 0010x010B
- ▲2: IICS0 = 0010x110B
- ▲3: IICS0 = 0010xx00B
- ▲4: IICS0 = 0001x110B
- ▲5: IICS0 = 0001xx00B
- △6: IICS0 = 00000001B

Remark ▲: Always generated
 △: Generated only when SPIE0 = 1
 x: Don't care

(c) Start ~ Code ~ Data ~ Start ~ Code ~ Data ~ Stop

(i) When WTIM0 = 0 (after restart, extension code reception)

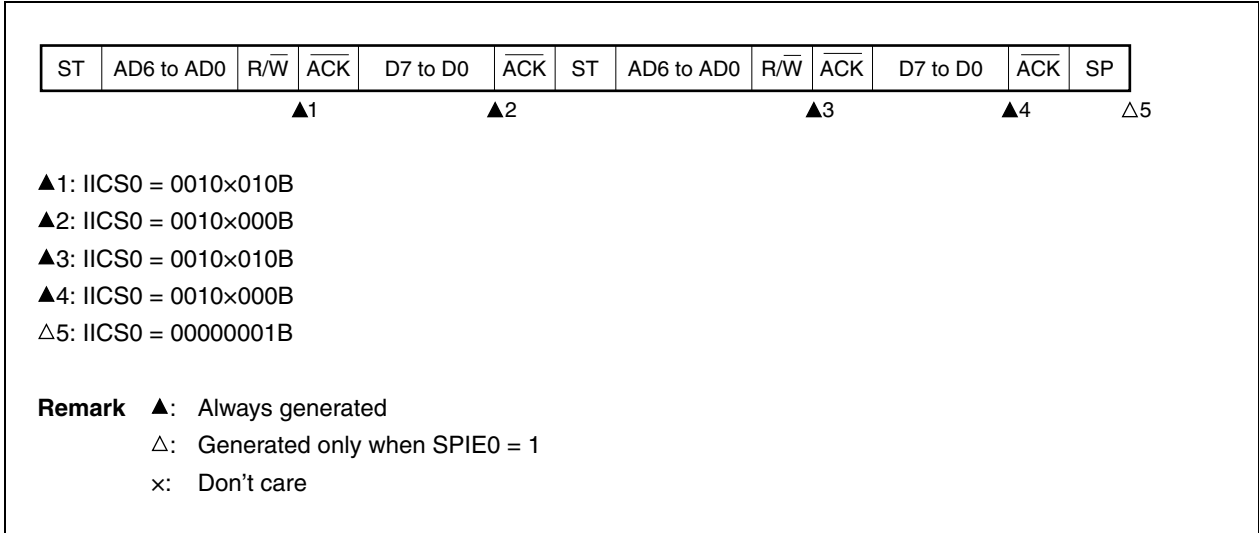

(ii) When WTIM0 = 1 (after restart, extension code reception)

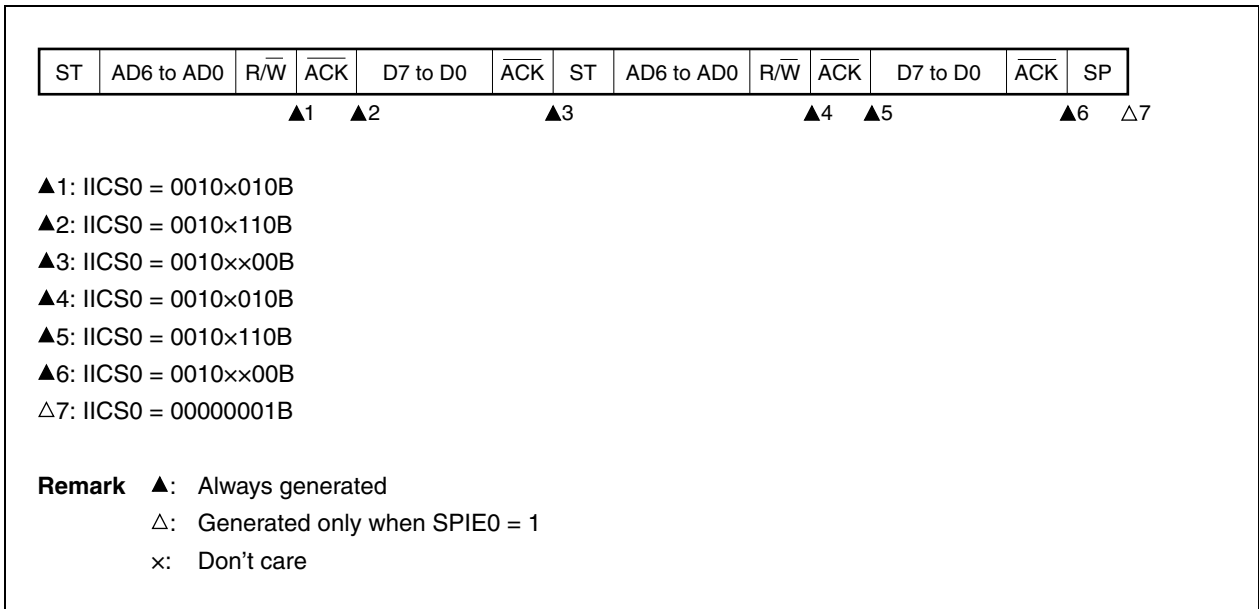

(d) Start ~ Code ~ Data ~ Start ~ Address ~ Data ~ Stop

(i) When WTIM0 = 0 (after restart, does not match address (= not extension code))

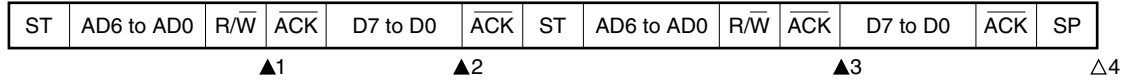

★ ▲1: IICS0 = 00100010B

★ ▲2: IICS0 = 00100000B

★ ▲3: IICS0 = 00000110B

△4: IICS0 = 00000001B

Remark ▲: Always generated

△: Generated only when SPIE0 = 1

x: Don't care

(ii) When WTIM0 = 1 (after restart, does not match address (= not extension code))

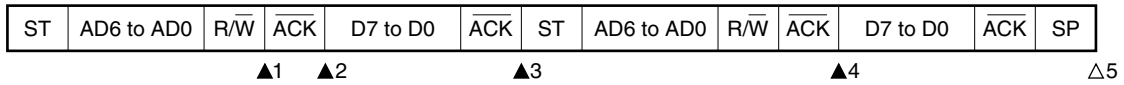

★ ▲1: IICS0 = 00100010B

★ ▲2: IICS0 = 00100110B

★ ▲3: IICS0 = 00100x00B

★ ▲4: IICS0 = 00000110B

△5: IICS0 = 00000001B

Remark ▲: Always generated

△: Generated only when SPIE0 = 1

x: Don't care

(4) Operation without communication

(a) Start ~ Code ~ Data ~ Data ~ Stop

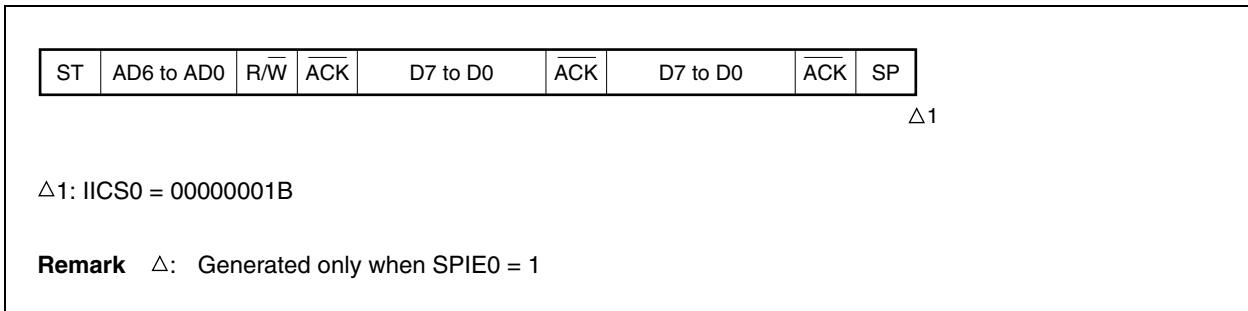

(5) Arbitration loss operation (operation as slave after arbitration loss)

★ When the device is used as a master in a multi-master system, read the MSTS0 bit each time interrupt request signal INTIIC0 has occurred to check the arbitration result.

(a) When arbitration loss occurs during transmission of slave address data

(i) When WTIM0 = 0

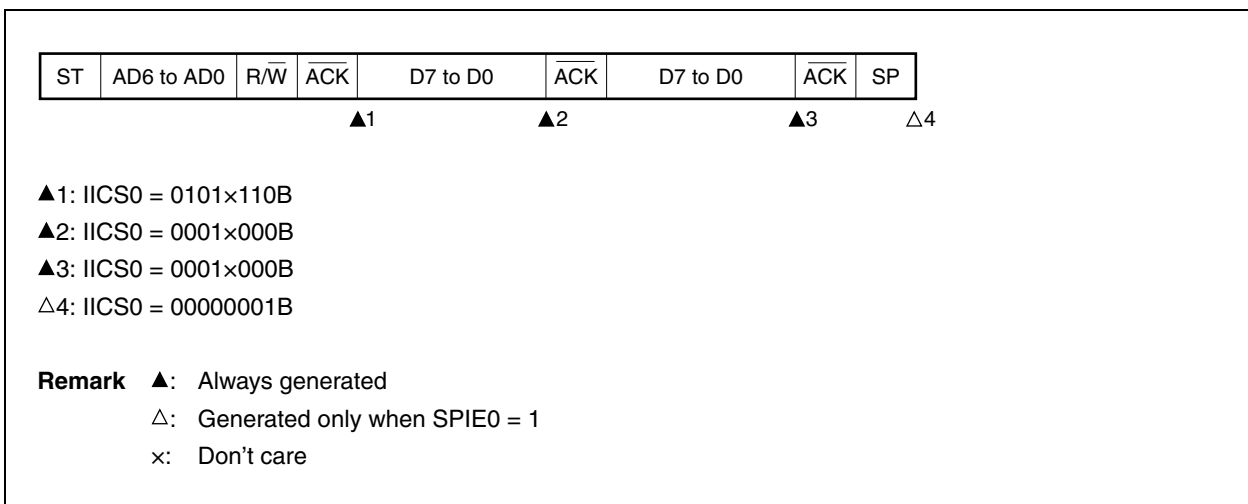

(ii) When WTIM0 = 1

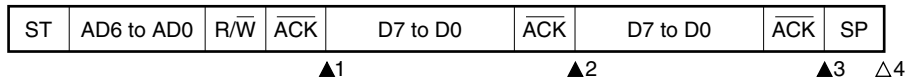

▲1: IICS0 = 0101x110B

▲2: IICS0 = 0001x100B

▲3: IICS0 = 0001x×00B

△4: IICS0 = 00000001B

Remark ▲: Always generated
 △: Generated only when SPIE0 = 1
 x: Don't care

(b) When arbitration loss occurs during transmission of extension code

(i) When WTIM0 = 0

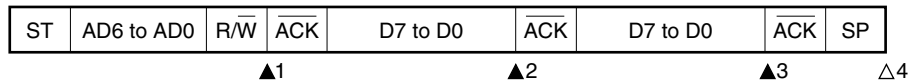

▲1: IICS0 = 0110x010B

▲2: IICS0 = 0010x000B

▲3: IICS0 = 0010x000B

△4: IICS0 = 00000001B

Remark ▲: Always generated
 △: Generated only when SPIE0 = 1
 x: Don't care

(ii) When WTIM0 = 1

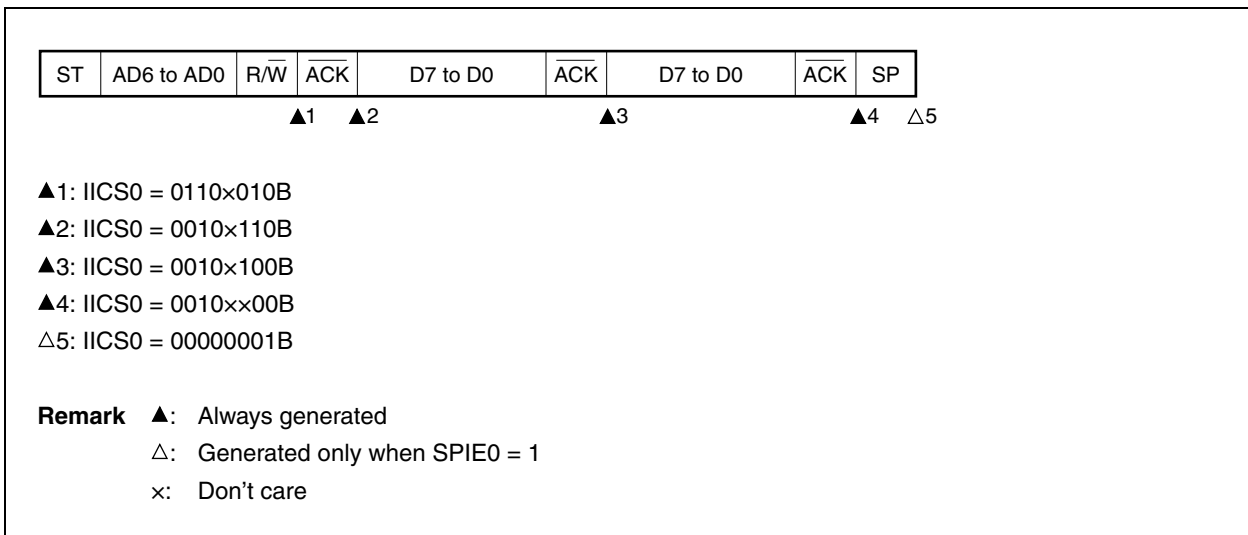

(6) Operation when arbitration loss occurs (no communication after arbitration loss)

★ When the device is used as a master in a multi-master system, read the MSTS0 bit each time interrupt request signal INTIIC0 has occurred to check the arbitration result.

(a) When arbitration loss occurs during transmission of slave address data (when WTIM0 = 1)

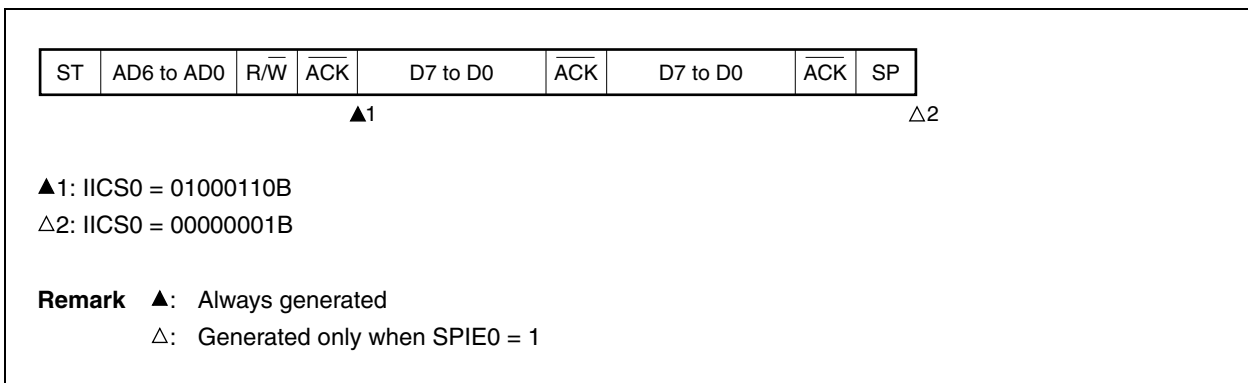

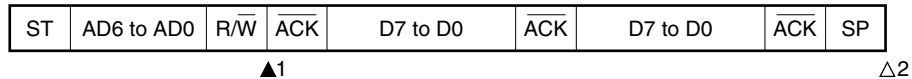
(b) When arbitration loss occurs during transmission of extension code

▲1: IIC0 = 0110x010B

Sets LREL0 = 1 by software

△2: IIC0 = 00000001B

Remark ▲: Always generated

△: Generated only when SPIE0 = 1

x: Don't care

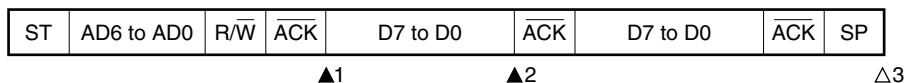
(c) When arbitration loss occurs during transmission of data**(i) When WTIM0 = 0**

▲1: IIC0 = 10001110B

▲2: IIC0 = 01000000B

△3: IIC0 = 00000001B

Remark ▲: Always generated

△: Generated only when SPIE0 = 1

(ii) When $WTIM0 = 1$

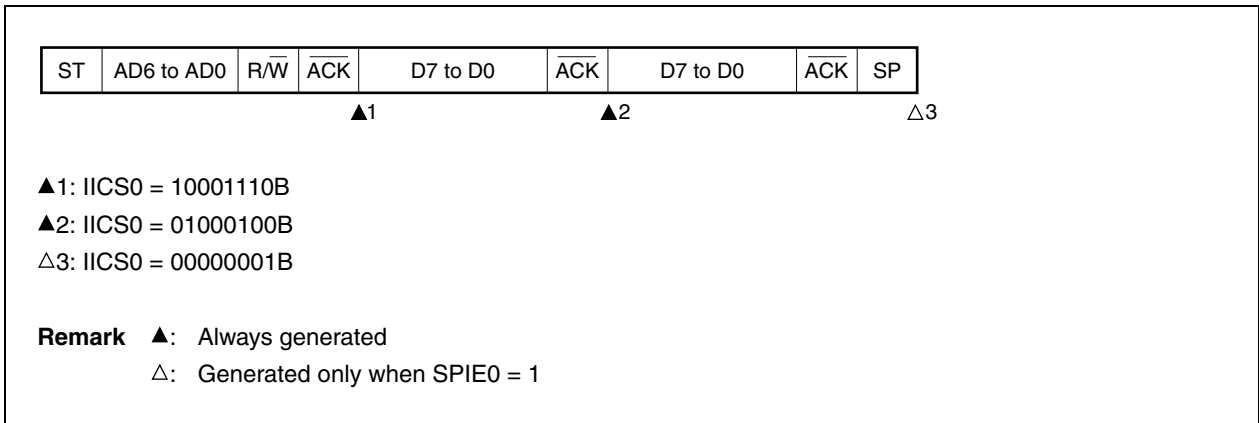

(d) When loss occurs due to restart condition during data transfer

(i) Not extension code (Example: unmatches with SVA0)

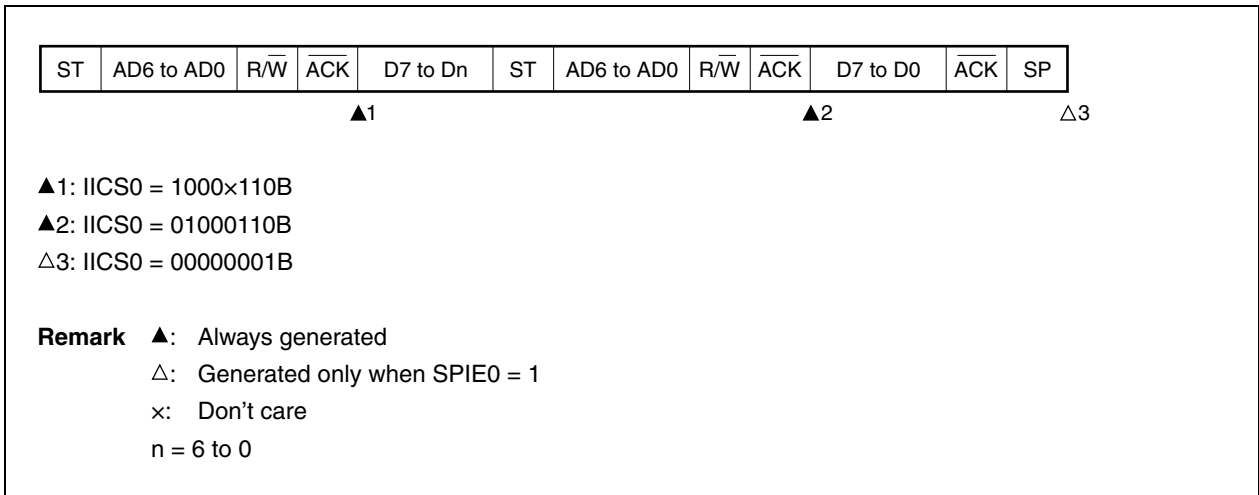

(ii) Extension code

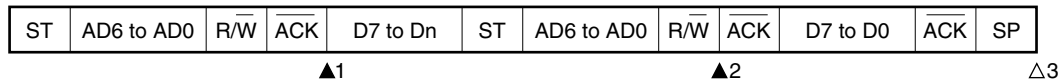

▲1: IICS0 = 1000x110B

▲2: IICS0 = 01100010B

Sets LREL0 = 1 by software

△3: IICS0 = 00000001B

Remark ▲: Always generated

△: Generated only when SPIE0 = 1

x: Don't care

n = 6 to 0

(e) When loss occurs due to stop condition during data transfer

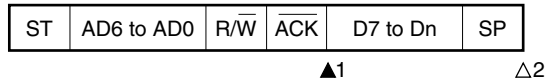

▲1: IICS0 = 10000110B

△2: IICS0 = 01000001B

Remark ▲: Always generated

△: Generated only when SPIE0 = 1

x: Don't care

n = 6 to 0

(f) When arbitration loss occurs due to low-level data when attempting to generate a restart condition

★

(i) When $WTIM0 = 0$

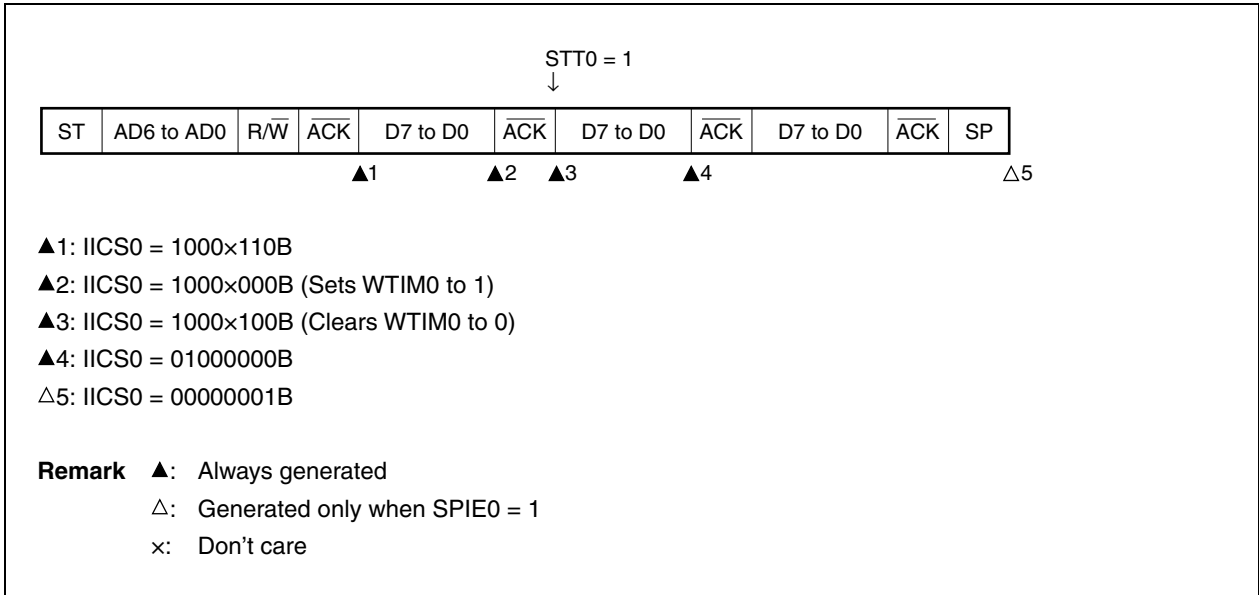

(ii) When $WTIM0 = 1$

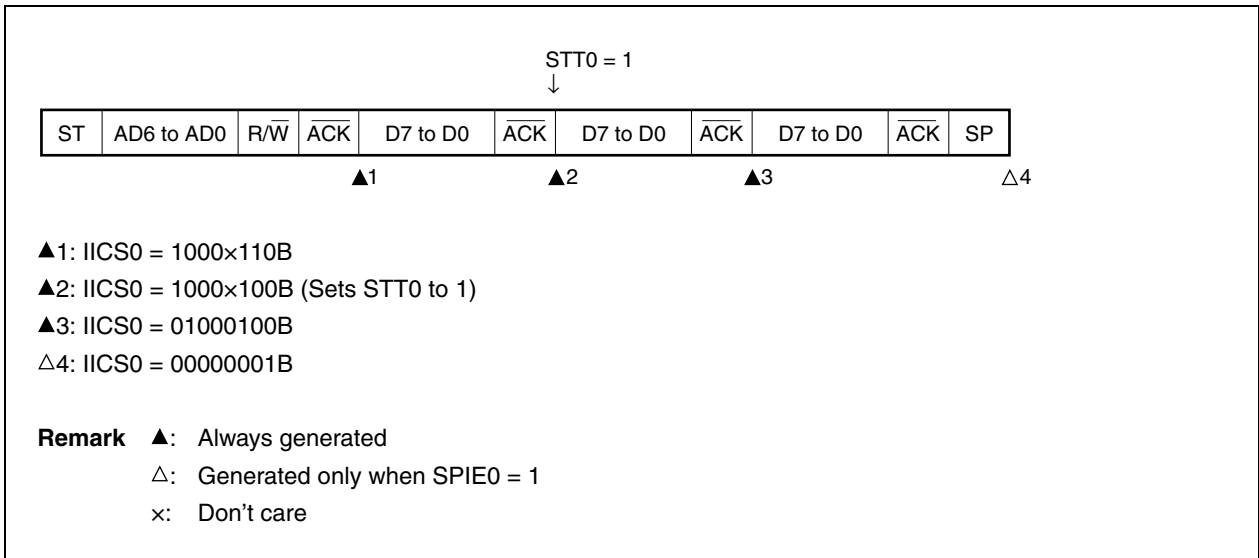

(g) When arbitration loss occurs due to a stop condition when attempting to generate a restart condition

★ (i) When $WTIM0 = 0$

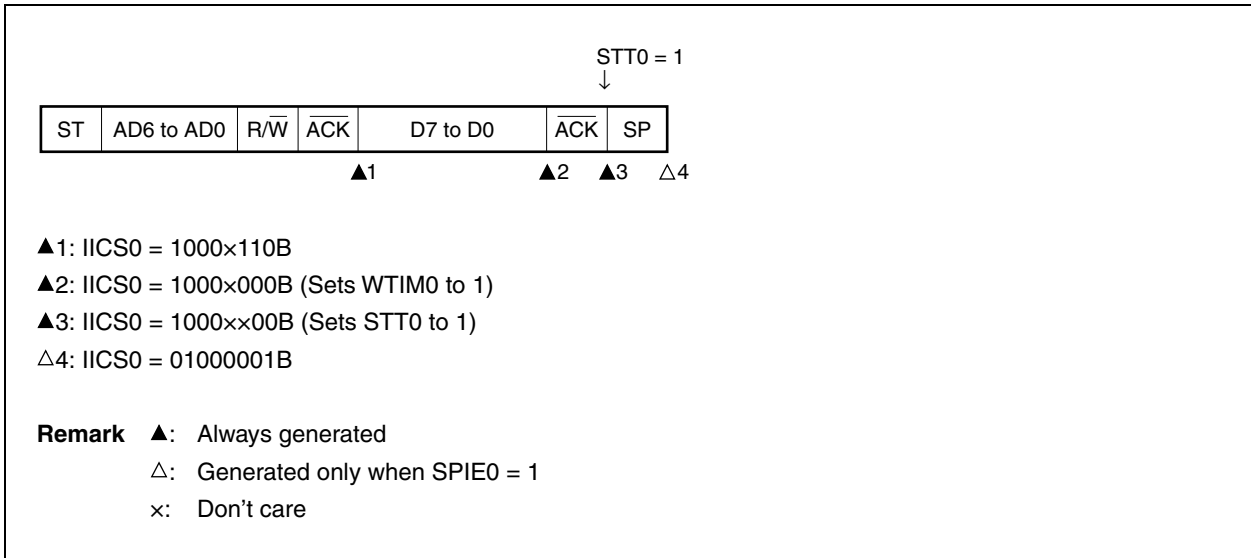

(ii) When $WTIM0 = 1$

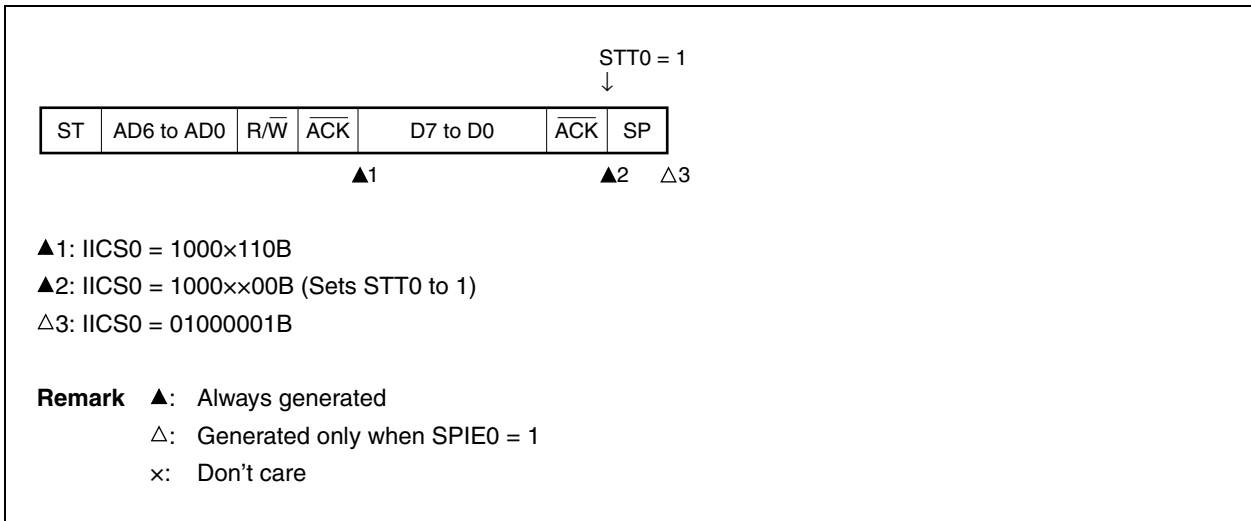

(h) When arbitration loss occurs due to low-level data when attempting to generate a stop condition

★

(i) When WTIM0 = 0

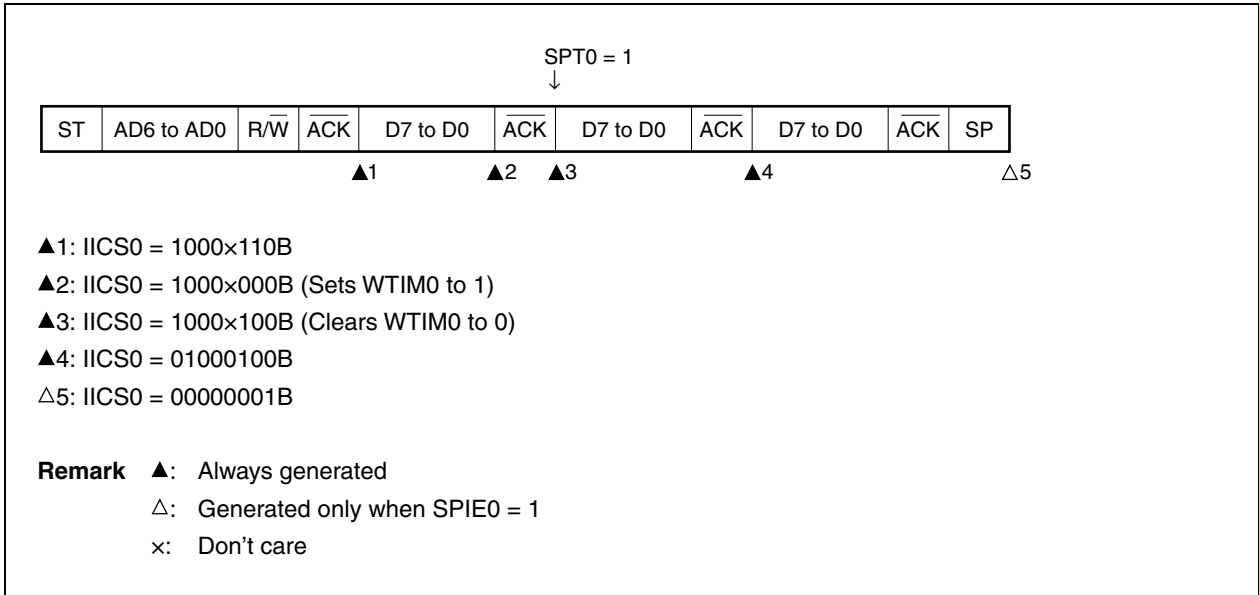

(ii) When WTIM0 = 1

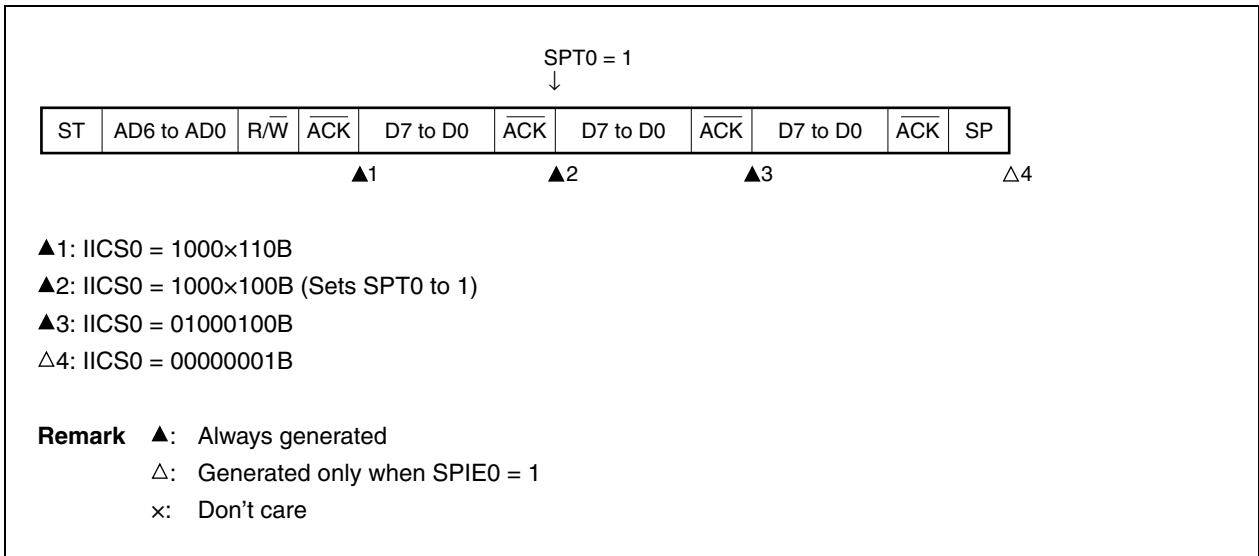

★

★

17.6 Timing Charts

When using the I²C bus mode, the master device outputs an address via the serial bus to select one of several slave devices as its communication partner.

After outputting the slave address, the master device transmits the TRC0 bit (bit 3 of IIC status register 0 (IICS0)), which specifies the data transfer direction, and then starts serial communication with the slave device.

Figures 17-27 and 17-28 show timing charts of the data communication.

IIC shift register 0 (IIC0)'s shift operation is synchronized with the falling edge of the serial clock (SCL0). The transmit data is transferred to the SO0 latch and is output (MSB first) via the SDA0 pin.

Data input via the SDA0 pin is captured into IIC0 at the rising edge of SCL0.

★

**Figure 17-27. Example of Master to Slave Communication
(When 9-Clock Wait Is Selected for Both Master and Slave) (1/3)**

(1) Start condition ~ address

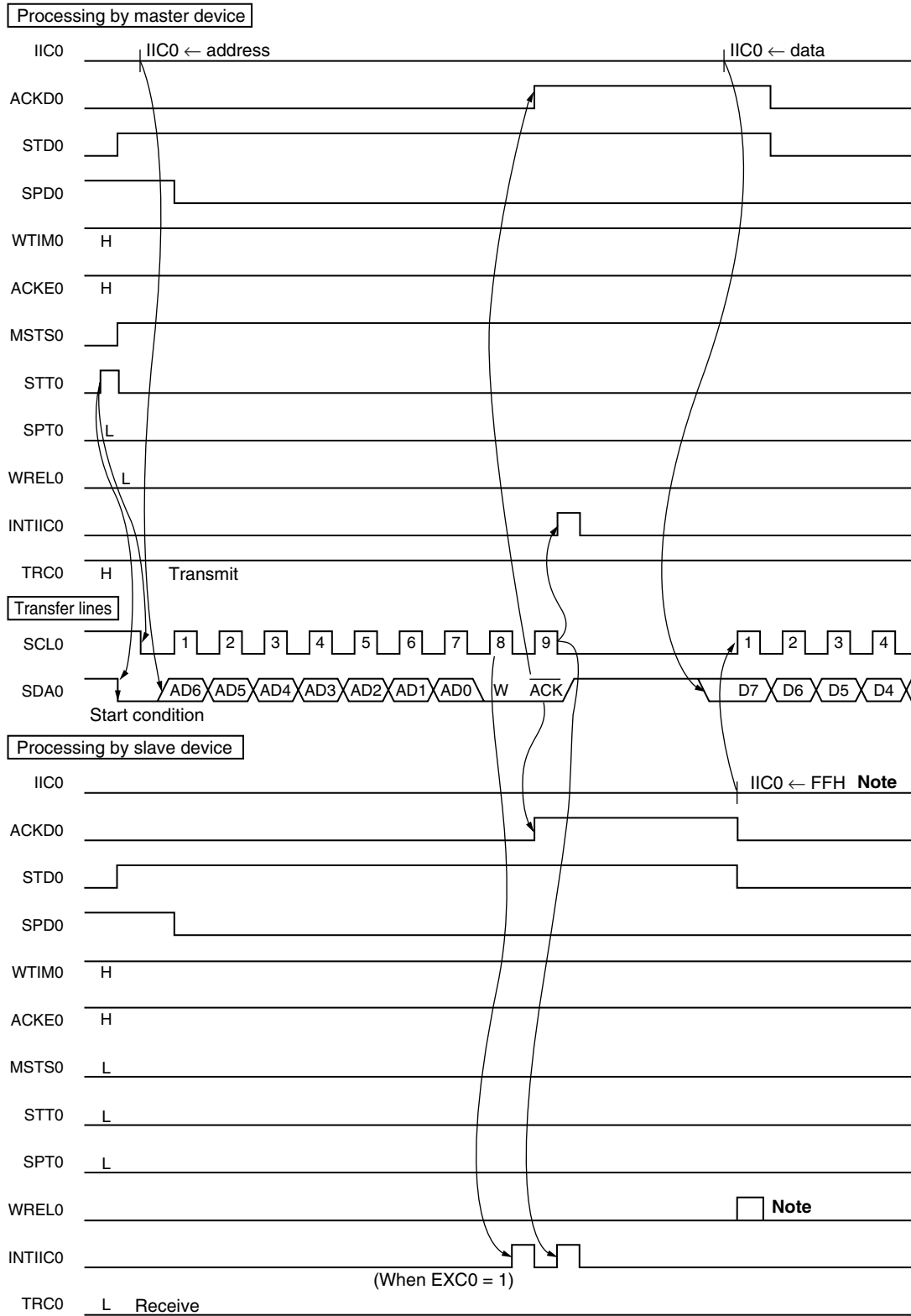

Note To cancel slave wait, write "FFH" to IIC0 or set WREL0.

★

**Figure 17-27. Example of Master to Slave Communication
(When 9-Clock Wait Is Selected for Both Master and Slave) (2/3)**

(2) Data

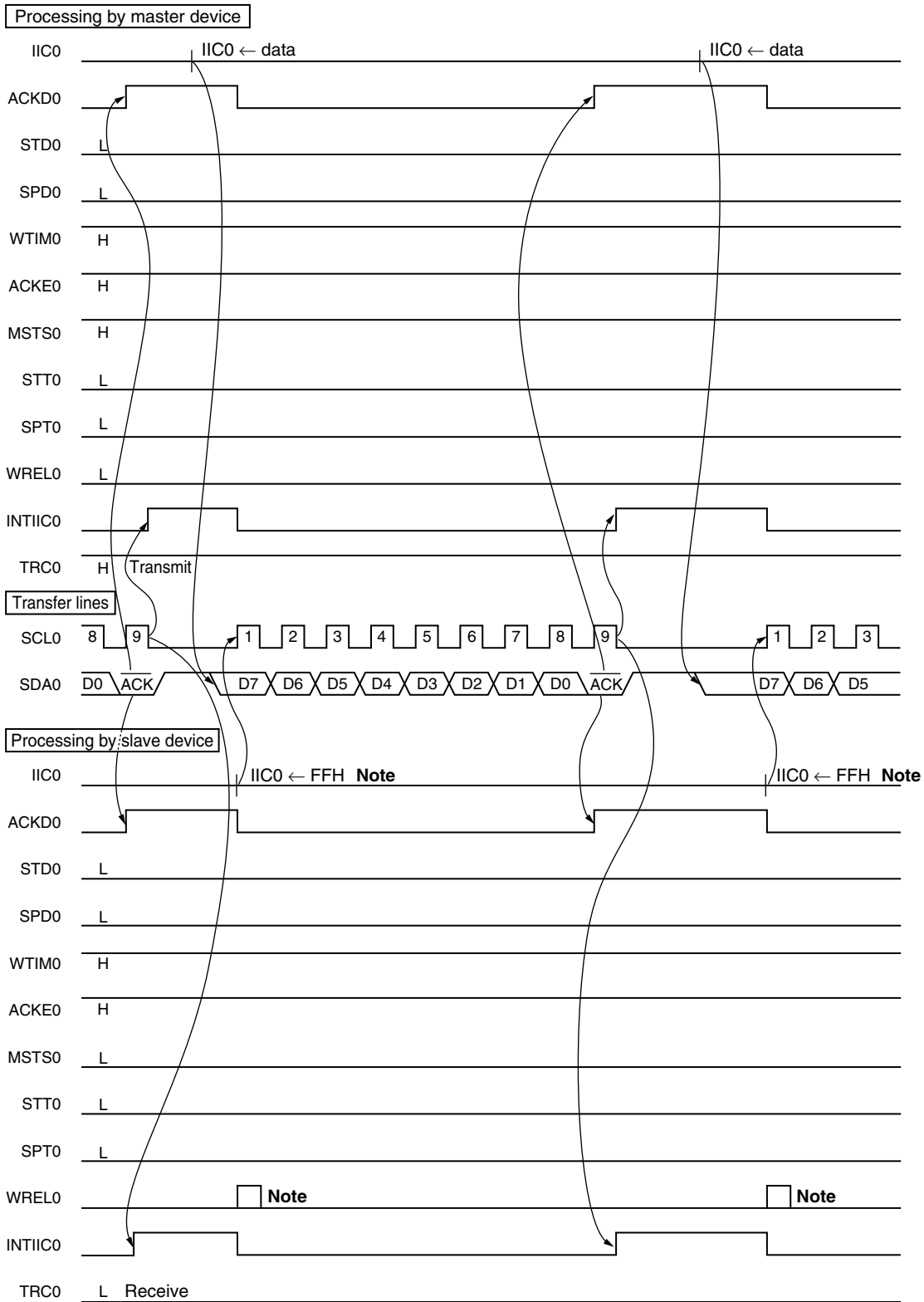

Note To cancel slave wait, write “FFH” to IIC0 or set WRELO.

★

**Figure 17-27. Example of Master to Slave Communication
(When 9-Clock Wait Is Selected for Both Master and Slave) (3/3)**

(3) Stop condition

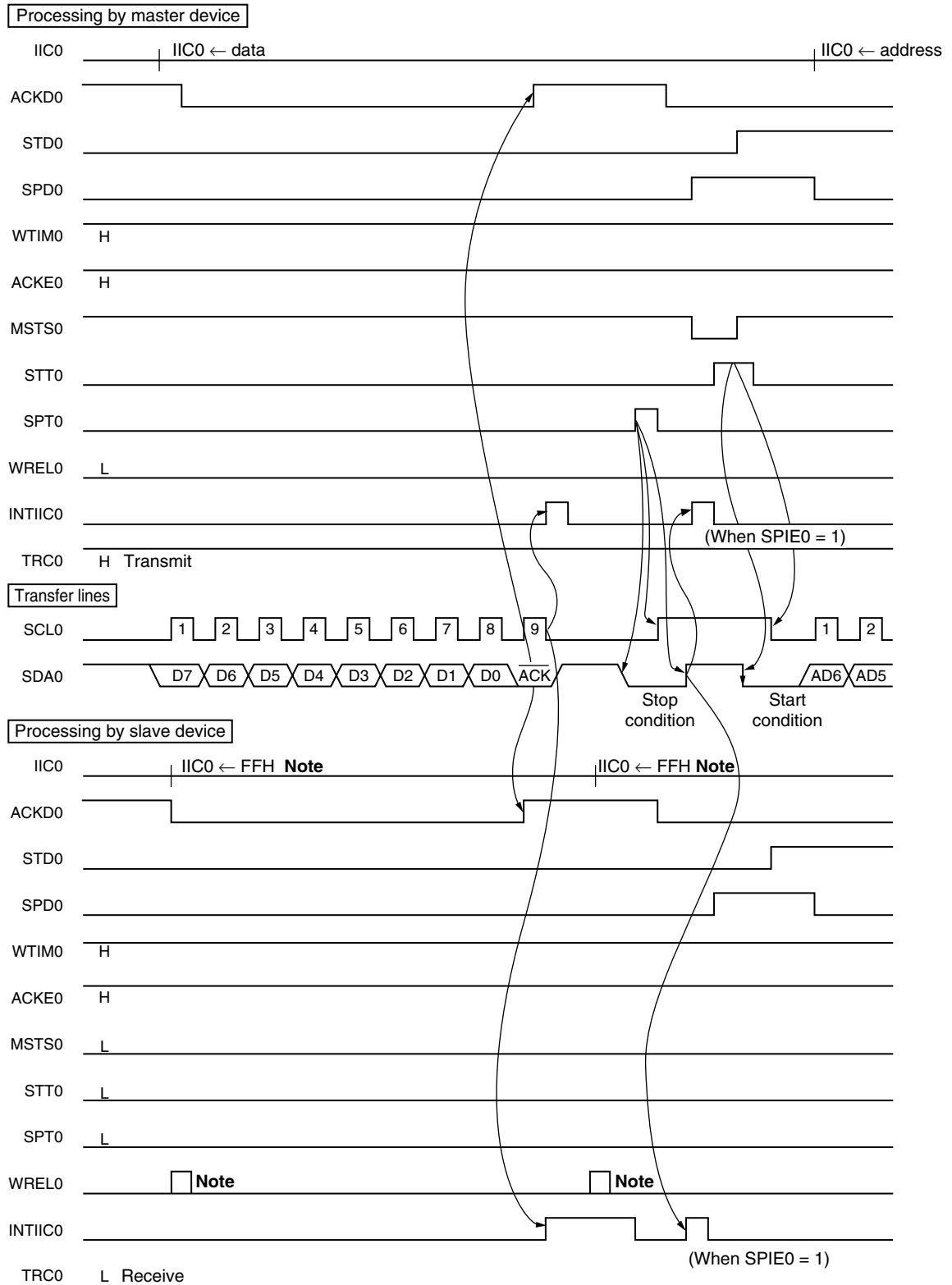

Note To cancel slave wait, write "FFH" to IIC0 or set WRELO.

★

Figure 17-28. Example of Slave to Master Communication
(When 8-Clock Wait Is Selected for Master, 9-Clock Wait Is Selected for Slave) (1/3)

(1) Start condition ~ address

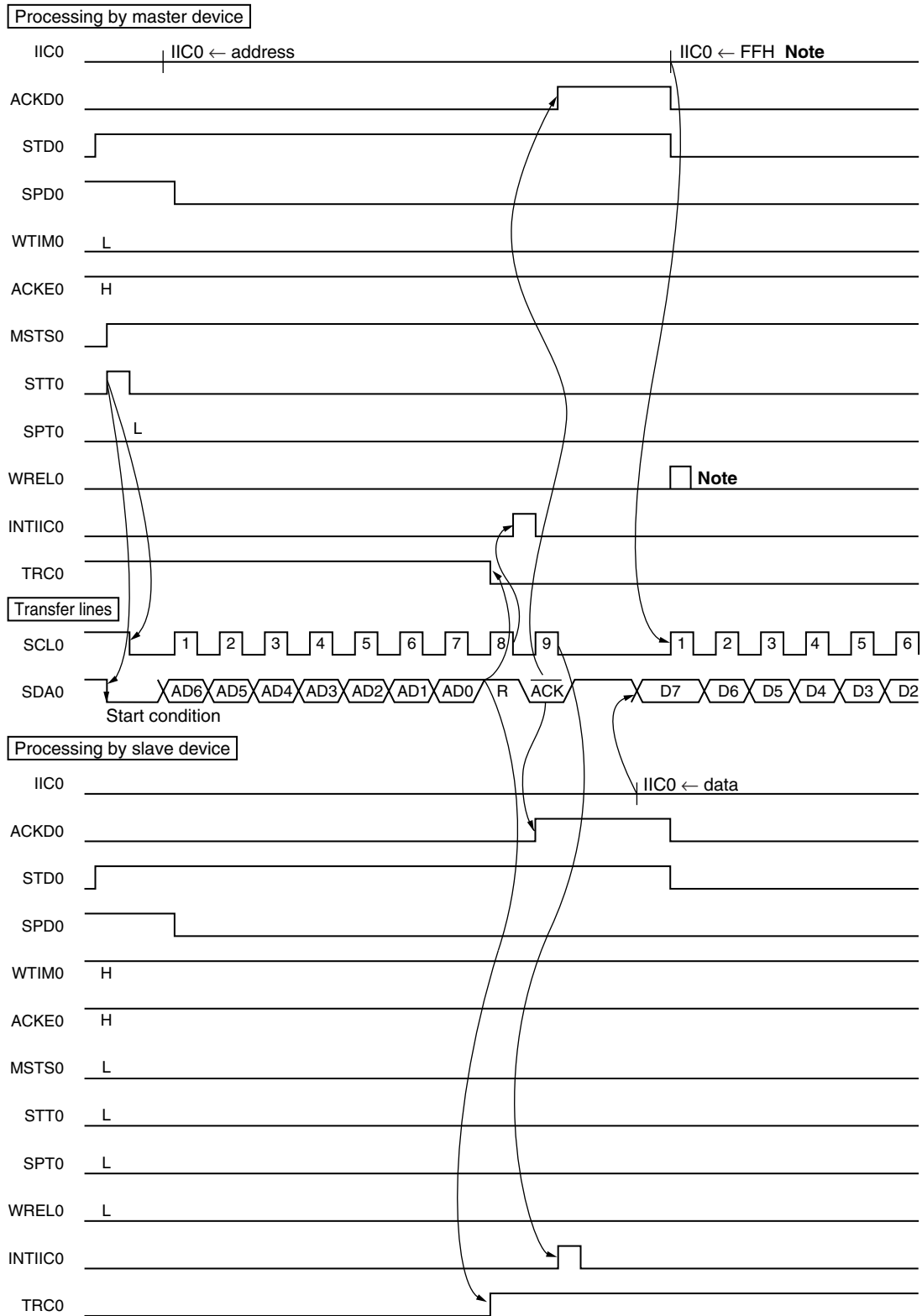

Note To cancel master wait, write "FFH" to IIC0 or set WREL0.

★

Figure 17-28. Example of Slave to Master Communication
 (When 8-Clock Wait Is Selected for Master, 9-Clock Wait Is Selected for Slave) (2/3)

(2) Data

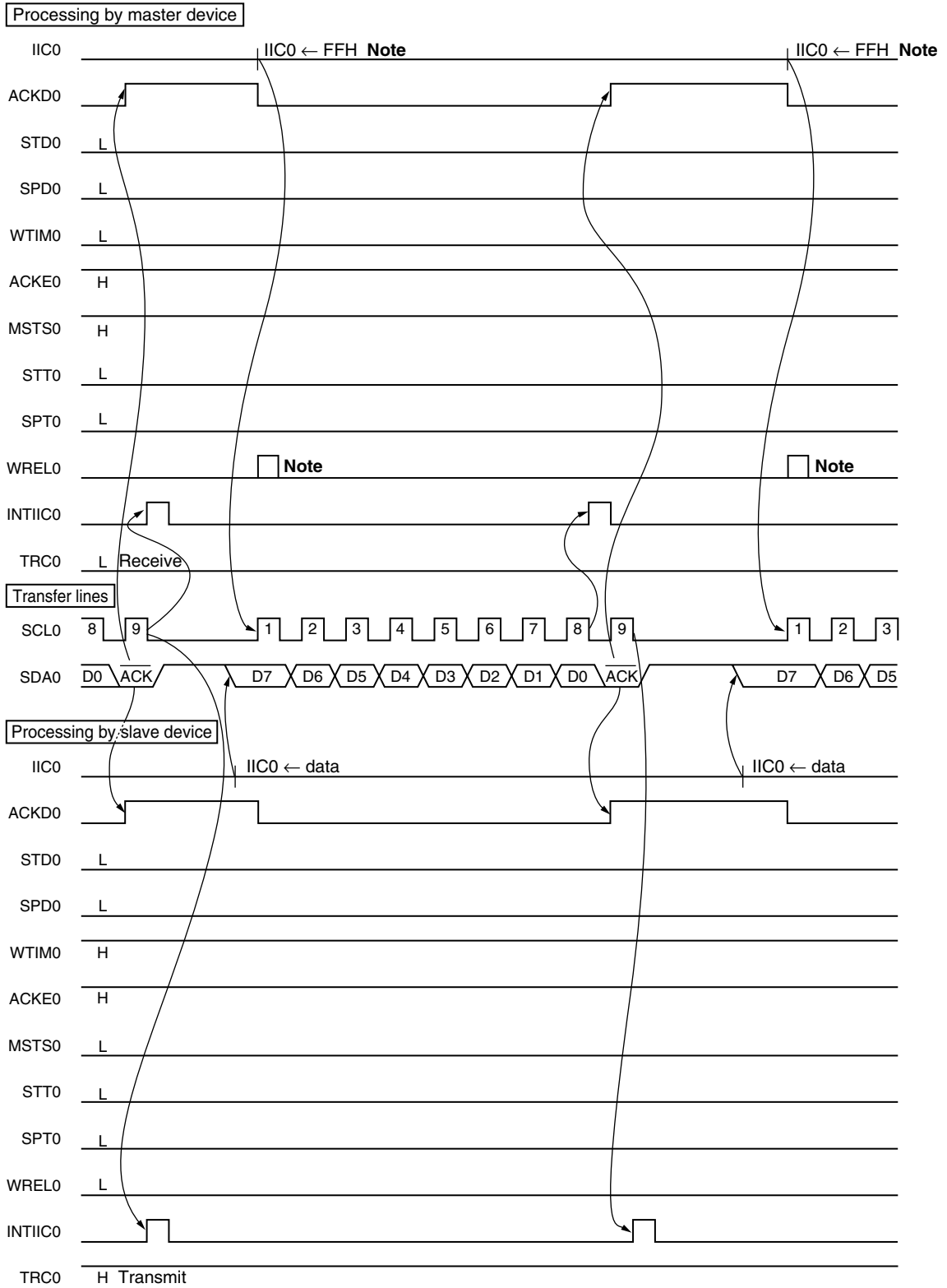

Note To cancel master wait, write "FFH" to IIC0 or set WREL0.

★

Figure 17-28. Example of Slave to Master Communication
 (When 8-Clock and 9-Clock Wait Is Selected for Master, 9-Clock Wait Is Selected for Slave) (3/3)

(3) Stop condition

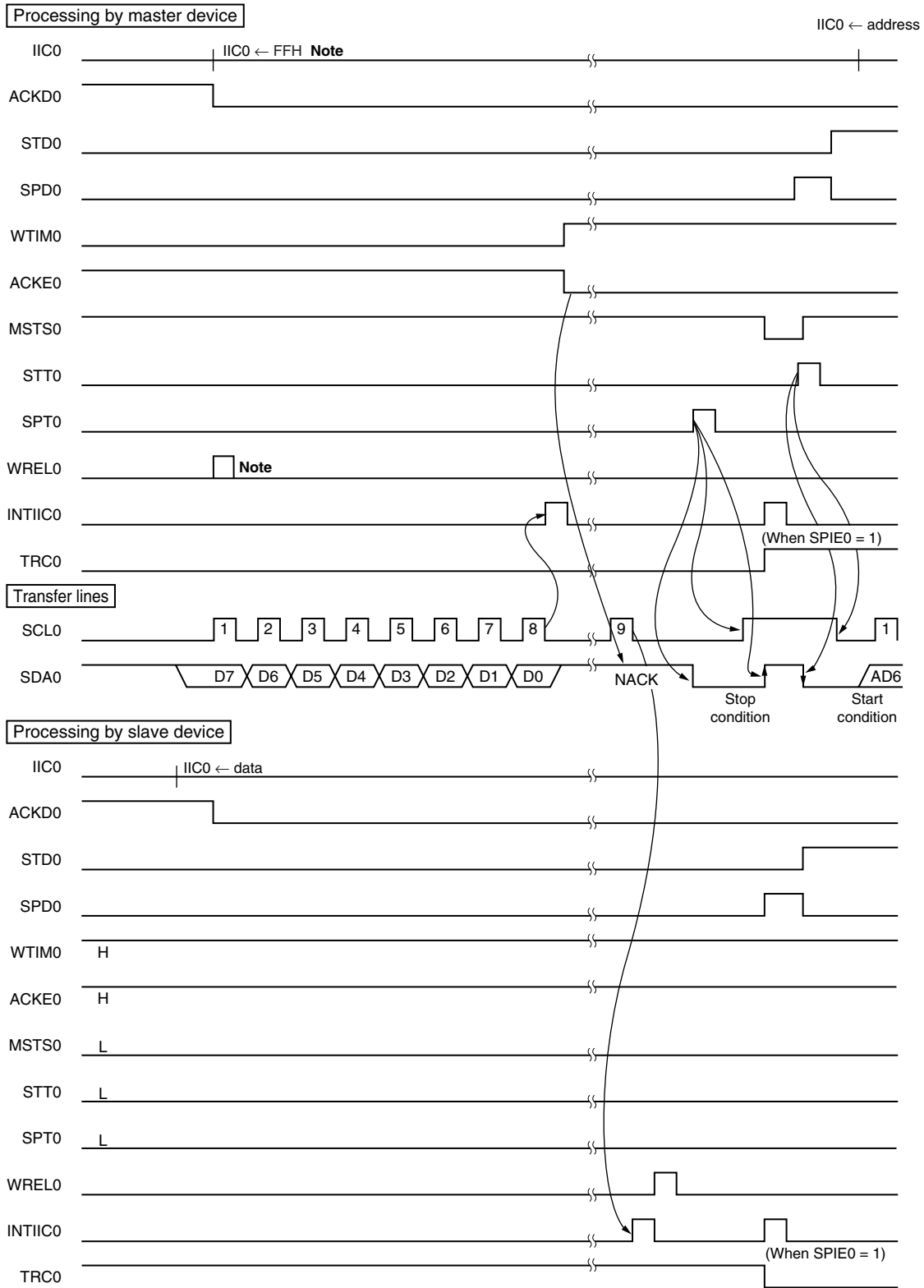

Note To cancel master wait, write “FFH” to IIC0 or set WREL0.

CHAPTER 18 MULTIPLIER/DIVIDER
(μ PD78F0534, 78F0535, 78F0536, 78F0537, AND 78F0537D ONLY)

Only for the μ PD78F0534, 78F0535, 78F0536, 78F0537, and 78F0537D, the multiplier/divider is provided.

18.1 Functions of Multiplier/Divider

The multiplier/divider has the following functions.

- 16 bits \times 16 bits = 32 bits (multiplication)
- 32 bits \div 16 bits = 32 bits, 16-bit remainder (division)

18.2 Configuration of Multiplier/Divider

The multiplier/divider includes the following hardware.

Table 18-1. Configuration of Multiplier/Divider

Item	Configuration
Registers	Remainder data register 0 (SDR0) Multiplication/division data registers A0 (MDA0H, MDA0L) Multiplication/division data registers B0 (MDB0)
Control register	Multiplication/divider control register 0 (DMUC0)

Figure 18-1 shows the block diagram of the multiplier/divider.

Figure 18-1. Block Diagram of Multiplier/Divider

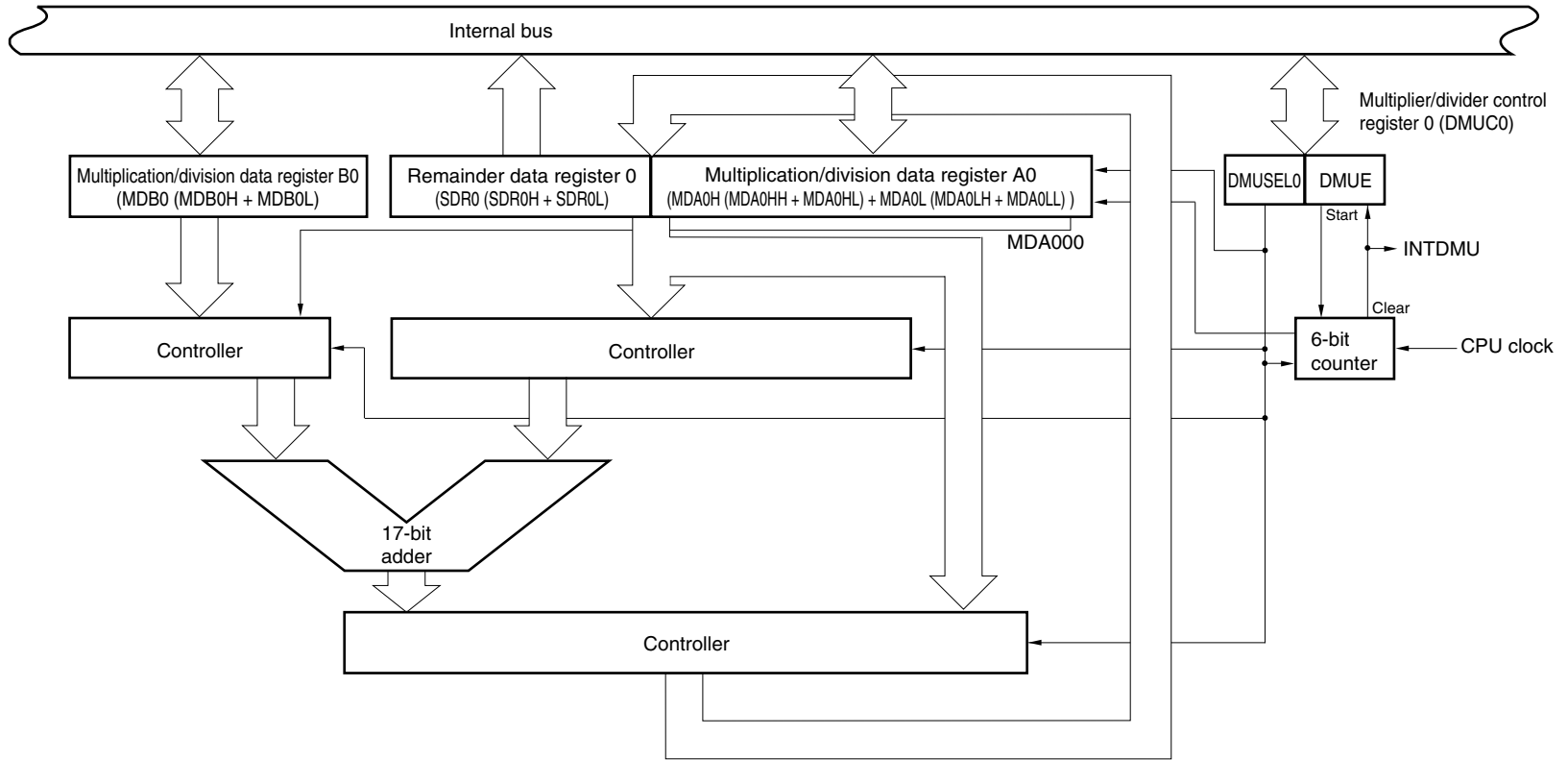

The functions of MDA0 when an operation is executed are shown in the table below.

Table 18-2. Functions of MDA0 During Operation Execution

DMUSEL0	Operation Mode	Setting	Operation Result
0	Division mode	Dividend	Division result (quotient)
1	Multiplication mode	Higher 16 bits: 0, Lower 16 bits: Multiplier A	Multiplication result (product)

The register configuration differs between when multiplication is executed and when division is executed, as follows.

- Register configuration during multiplication
 $\langle \text{Multiplier A} \rangle \quad \langle \text{Multiplier B} \rangle \quad \langle \text{Product} \rangle$
 $\text{MDA0 (bits 15 to 0)} \times \text{MDB0 (bits 15 to 0)} = \text{MDA0 (bits 31 to 0)}$
- Register configuration during division
 $\langle \text{Dividend} \rangle \quad \langle \text{Divisor} \rangle \quad \langle \text{Quotient} \rangle \quad \langle \text{Remainder} \rangle$
 $\text{MDA0 (bits 31 to 0)} \div \text{MDB0 (bits 15 to 0)} = \text{MDA0 (bits 31 to 0)} \dots \text{SDR0 (bits 15 to 0)}$

MDA0 fetches the calculation result as soon as the clock is input, when bit 7 (DMUE) of multiplier/divider control register 0 (DMUC0) is set to 1.

MDA0H and MDA0L can be set by an 8-bit or 16-bit memory manipulation instruction.

Reset signal generation clears MDA0H and MDA0L to 0000H.

(3) Multiplication/division data register B0 (MDB0)

MDB0 is a register that stores a 16-bit multiplier B in the multiplication mode and a 16-bit divisor in the division mode.

MDB0 can be set by an 8-bit or 16-bit memory manipulation instruction.

Reset signal generation sets MDB0 to 0000H.

Figure 18-4. Format of Multiplication/Division Data Register B0 (MDB0)

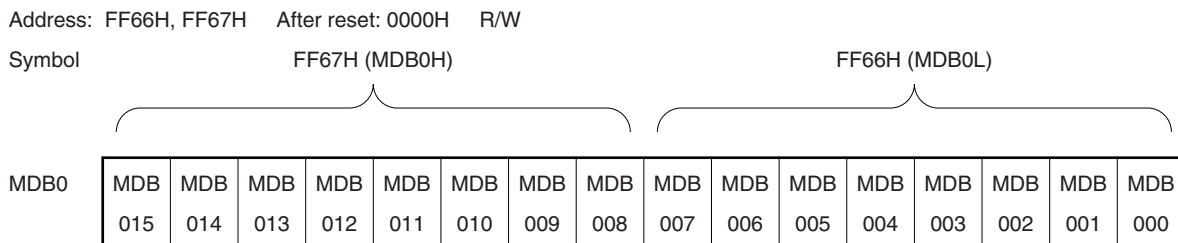

- Cautions**
1. Do not change the value of MDB0 during operation processing (while bit 7 (DMUE) of multiplier/divider control register 0 (DMUC0) is 1). Even in this case, the operation is executed, but the result is undefined.
 2. Do not clear MDB0 to 0000H in the division mode. If set, undefined operation results are stored in MDA0 and SDR0.

18.3 Register Controlling Multiplier/Divider

The multiplier/divider is controlled by multiplier/divider control register 0 (DMUC0).

(1) Multiplier/divider control register 0 (DMUC0)

DMUC0 is an 8-bit register that controls the operation of the multiplier/divider.

DMUC0 can be set by a 1-bit or 8-bit memory manipulation instruction.

Reset signal generation sets DMUC0 to 00H.

Figure 18-5. Format of Multiplier/Divider Control Register 0 (DMUC0)

Address: FF68H After reset: 00H R/W

Symbol	<7>	6	5	4	3	2	1	0
DMUC0	DMUE	0	0	0	0	0	0	DMUSEL0
DMUE ^{Note}	Operation start/stop							
0	Stops operation							
1	Starts operation							
DMUSEL0	Operation mode (multiplication/division) selection							
0	Division mode							
1	Multiplication mode							

Note When DMUE is set to 1, the operation is started. DMUE is automatically cleared to 0 after the operation is complete.

- Cautions**
1. If DMUE is cleared to 0 during operation processing (when DMUE is 1), the operation result is not guaranteed. If the operation is completed while the clearing instruction is being executed, the operation result is guaranteed, provided that the interrupt flag is set.
 2. Do not change the value of DMUSEL0 during operation processing (while DMUE is 1). If it is changed, undefined operation results are stored in multiplication/division data register A0 (MDA0) and remainder data register 0 (SDR0).
 3. If DMUE is cleared to 0 during operation processing (while DMUE is 1), the operation processing is stopped. To execute the operation again, set multiplication/division data register A0 (MDA0), multiplication/division data register B0 (MDB0), and multiplier/divider control register 0 (DMUC0), and start the operation (by setting DMUE to 1).

18.4 Operations of Multiplier/Divider

18.4.1 Multiplication operation

- Initial setting
 1. Set operation data to multiplication/division data register A0L (MDA0L) and multiplication/division data register B0 (MDB0).
 2. Set bits 0 (DMUSEL0) and 7 (DMUE) of multiplier/divider control register 0 (DMUC0) to 1. Operation will start.
- During operation
 3. The operation will be completed when 16 internal clocks have been issued after the start of the operation (intermediate data is stored in the MDA0L and MDA0H registers during operation, and therefore the read values of these registers are not guaranteed).
- End of operation
 4. The operation result data is stored in the MDA0L and MDA0H registers.
 5. DMUE is cleared to 0 (end of operation).
 6. After the operation, an interrupt request signal (INTDMU) is generated.
- Next operation
 7. To execute multiplication next, start from the initial setting in **18.4.1 Multiplication operation**.
 8. To execute division next, start from the initial setting in **18.4.2 Division operation**.

Figure 18-6. Timing Chart of Multiplication Operation (00DAH × 0093H)

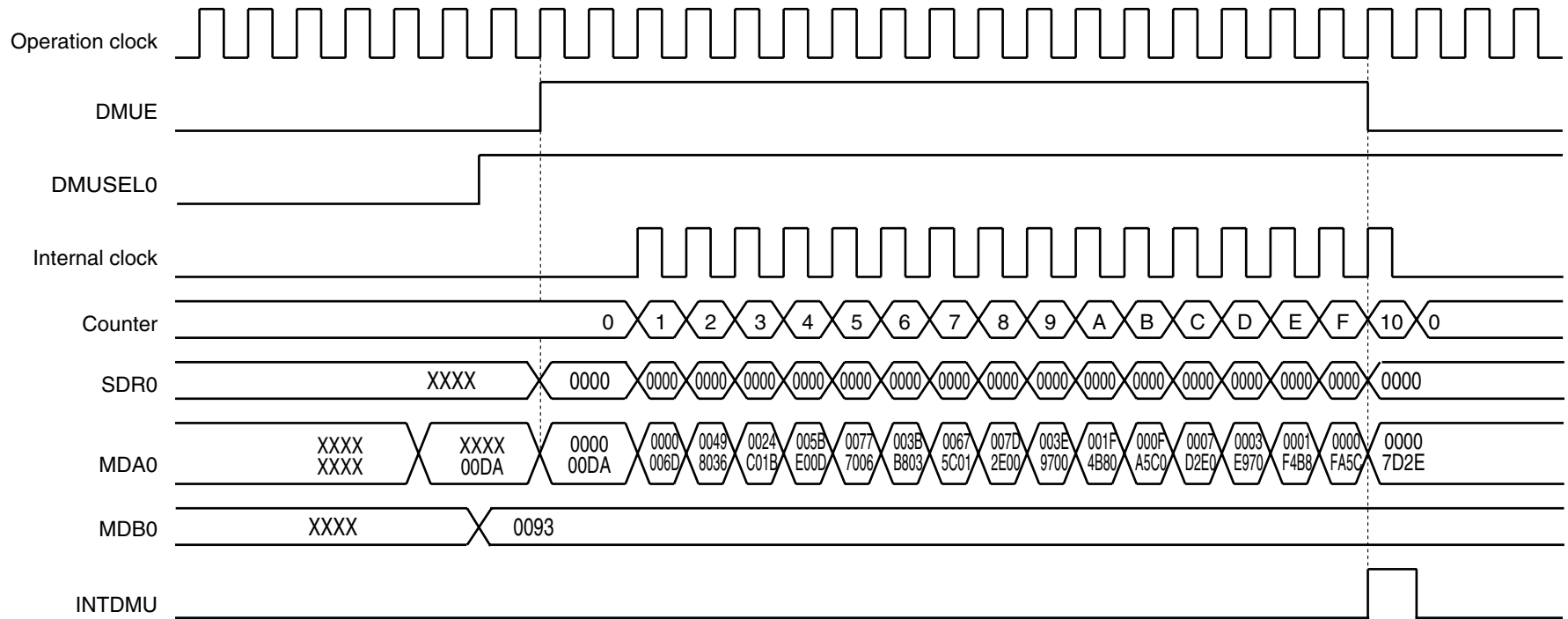

18.4.2 Division operation

- Initial setting
 1. Set operation data to multiplication/division data register A0 (MDA0L and MDA0H) and multiplication/division data register B0 (MDB0).
 2. Set bits 0 (DMUSEL0) and 7 (DMUE) of multiplier/divider control register 0 (DMUC0) to 0 and 1, respectively. Operation will start.
- During operation
 3. The operation will be completed when 32 internal clocks have been issued after the start of the operation (intermediate data is stored in the MDA0L and MDA0H registers and remainder data register 0 (SDR0) during operation, and therefore the read values of these registers are not guaranteed).
- End of operation
 4. The result data is stored in the MDA0L, MDA0H, and SDR0 registers.
 5. DMUE is cleared to 0 (end of operation).
 6. After the operation, an interrupt request signal (INTDMU) is generated.
- Next operation
 7. To execute multiplication next, start from the initial setting in **18.4.1 Multiplication operation**.
 8. To execute division next, start from the initial setting in **18.4.2 Division operation**.

Figure 18-7. Timing Chart of Division Operation (DCBA2586H + 0018H)

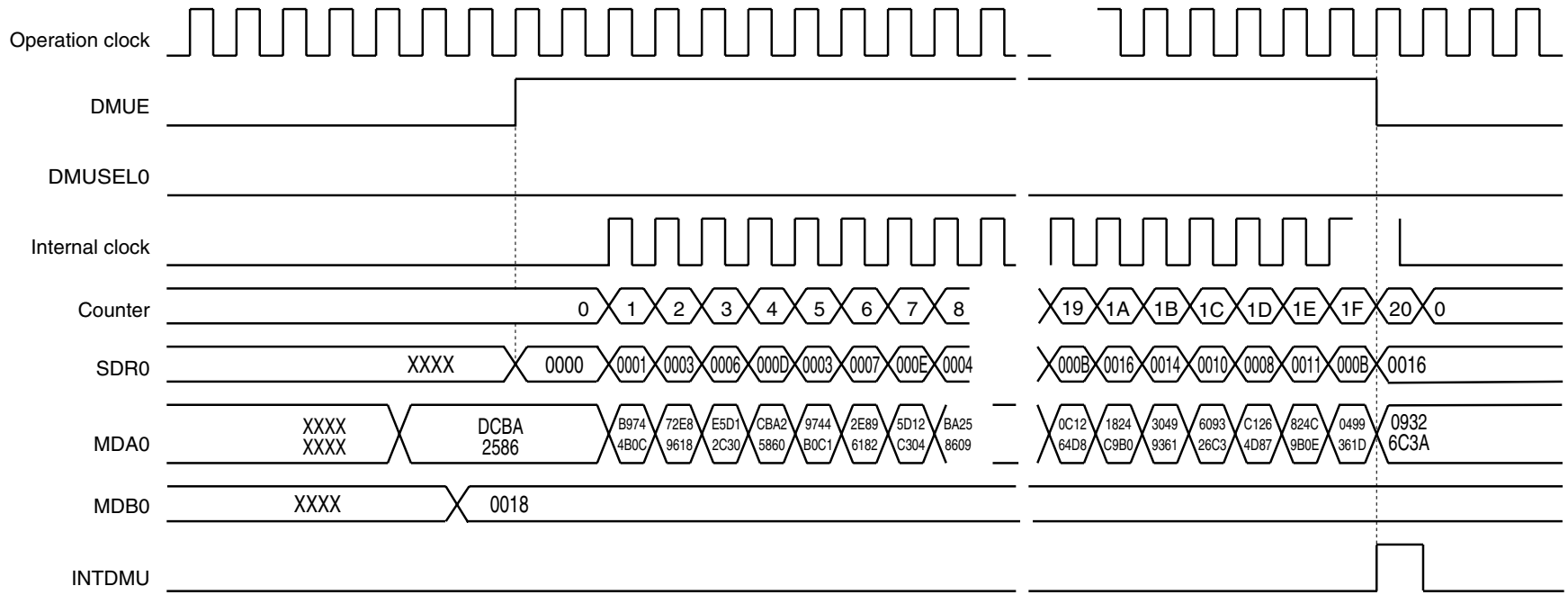

CHAPTER 19 INTERRUPT FUNCTIONS

19.1 Interrupt Function Types

The following two types of interrupt functions are used.

(1) Maskable interrupts

These interrupts undergo mask control. Maskable interrupts can be divided into a high interrupt priority group and a low interrupt priority group by setting the priority specification flag registers (PR0L, PR0H, PR1L, PR1H). Multiple interrupt servicing can be applied to low-priority interrupts when high-priority interrupts are generated. If two or more interrupt requests, each having the same priority, are simultaneously generated, then they are processed according to the priority of vectored interrupt servicing. For the priority order, see **Table 19-1**.

A standby release signal is generated and STOP and HALT modes are released.

External interrupt requests and internal interrupt requests are provided as maskable interrupts.

- μ PD78F0531, 78F0532, 78F0533
External: 9, internal: 16
- μ PD78F0534, 78F0535, 78F0536, 78F0537, 78F0537D
External: 9, internal: 19

(2) Software interrupt

This is a vectored interrupt generated by executing the BRK instruction. It is acknowledged even when interrupts are disabled. The software interrupt does not undergo interrupt priority control.

19.2 Interrupt Sources and Configuration

The μ PD78F0531, 78F0532, and 78F0533 have a total of 26 interrupt sources, and the μ PD78F0534, 78F0535, 78F0536, 78F0537, and 78F0537D have a total of 29 interrupt sources, including maskable interrupts and software interrupts. In addition, they also have up to four reset sources (see **Table 19-1**).

Table 19-1. Interrupt Source List (1/2)

Interrupt Type	Default Priority ^{Note 1}	Interrupt Source		Internal/ External	Vector Table Address	Basic Configuration Type ^{Note 2}
		Name	Trigger			
Maskable	0	INTLVI	Low-voltage detection ^{Note 3}	Internal	0004H	(A)
	1	INTP0	Pin input edge detection	External	0006H	(B)
	2	INTP1			0008H	
	3	INTP2			000AH	
	4	INTP3			000CH	
	5	INTP4			000EH	
	6	INTP5			0010H	
	7	INTSRE6	UART6 reception error generation	Internal	0012H	(A)
	8	INTSR6	End of UART6 reception		0014H	
	9	INTST6	End of UART6 transmission		0016H	
	10	INTCSI10/ INTST0	End of CSI10 communication/end of UART0 transmission		0018H	
	11	INTTMH1	Match between TMH1 and CMP01 (when compare register is specified)		001AH	
	12	INTTMH0	Match between TMH0 and CMP00 (when compare register is specified)		001CH	
	13	INTTM50	Match between TM50 and CR50 (when compare register is specified)		001EH	
	14	INTTM000	Match between TM00 and CR000 (when compare register is specified), TI010 pin valid edge detection (when capture register is specified)		0020H	
	15	INTTM010	Match between TM00 and CR010 (when compare register is specified), TI000 pin valid edge detection (when capture register is specified)		0022H	
	16	INTAD	End of A/D conversion		0024H	
	17	INTSR0	End of UART0 reception or reception error generation		0026H	
	18	INTWTI	Watch timer reference time interval signal		0028H	
	19	INTTM51	Match between TM51 and CR51 (when compare register is specified)		002AH	
	20	INTKR	Key interrupt detection	External	002CH	(C)
	21	INTWT	Watch timer overflow	Internal	002EH	(A)
	22	INTP6	Pin input edge detection	External	0030H	(B)
23	INTP7	0032H				

- Notes**
1. The default priority determines the sequence of processing vectored interrupts if two or more maskable interrupts occur simultaneously. Zero indicates the highest priority and 27 indicates the lowest priority.
 2. Basic configuration types (A) to (D) correspond to (A) to (D) in Figure 19-1.
 3. When bit 1 (LVIMD) of the low-voltage detection register (LVIM) is cleared to 0.

Table 19-1. Interrupt Source List (2/2)

Interrupt Type	Default Priority ^{Note 1}	Interrupt Source		Internal/ External	Vector Table Address	Basic Configuration Type ^{Note 2}
		Name	Trigger			
Maskable	24	INTIIC0/ INTDMU ^{Note 3}	End of IIC0 communication/end of multiply/divide operation	Internal	0034H	(A)
	25	INTCSI11 ^{Note 3}	End of CSI11 communication		0036H	
	26	INTTM001 ^{Note 3}	Match between TM01 and CR001 (when compare register is specified), TI011 pin valid edge detection (when capture register is specified)		0038H	
	27	INTTM011 ^{Note 3}	Match between TM01 and CR011 (when compare register is specified), TI001 pin valid edge detection (when capture register is specified)		003AH	
Software	–	BRK	BRK instruction execution	–	003EH	(D)
Reset	–	RESET	Reset input	–	0000H	–
		POC	Power-on clear			
		LVI	Low-voltage detection ^{Note 4}			
		WDT	WDT overflow			

- Notes**
1. The default priority is the priority applicable when two or more maskable interrupts are generated simultaneously. 0 is the highest priority, and 27 is the lowest.
 2. Basic configuration types (A) to (D) correspond to (A) to (D) in Figure 19-1.
 3. The interrupt sources INTDMU, INTCSI11, INTTM001, and INTTM011 are available only in the μ PD78F0534, 78F0535, 78F0536, 78F0537, and 78F0537D.
 4. When bit 1 (LVIMD) of the low-voltage detection register (LVIM) is set to 1.

Figure 19-1. Basic Configuration of Interrupt Function (1/2)

(A) Internal maskable interrupt

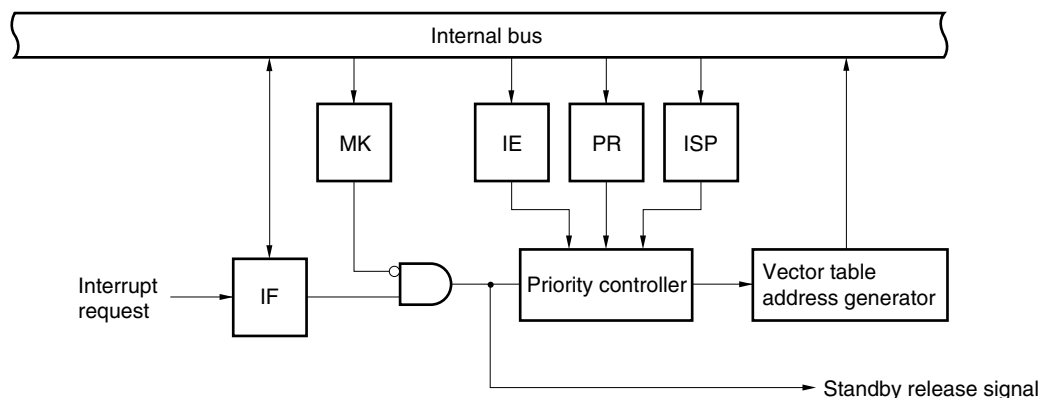

(B) External maskable interrupt (INTP0 to INTP7)

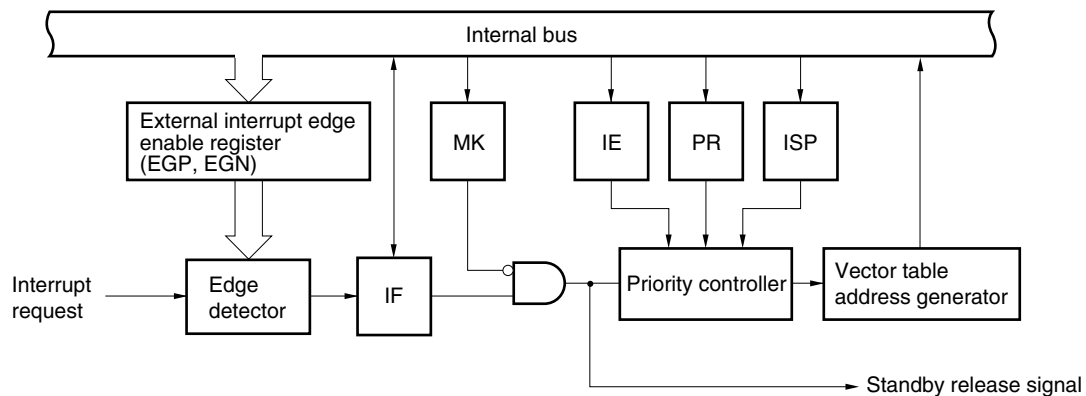

- IF: Interrupt request flag
- IE: Interrupt enable flag
- ISP: In-service priority flag
- MK: Interrupt mask flag
- PR: Priority specification flag

Figure 19-1. Basic Configuration of Interrupt Function (2/2)

(C) External maskable interrupt (INTKR)

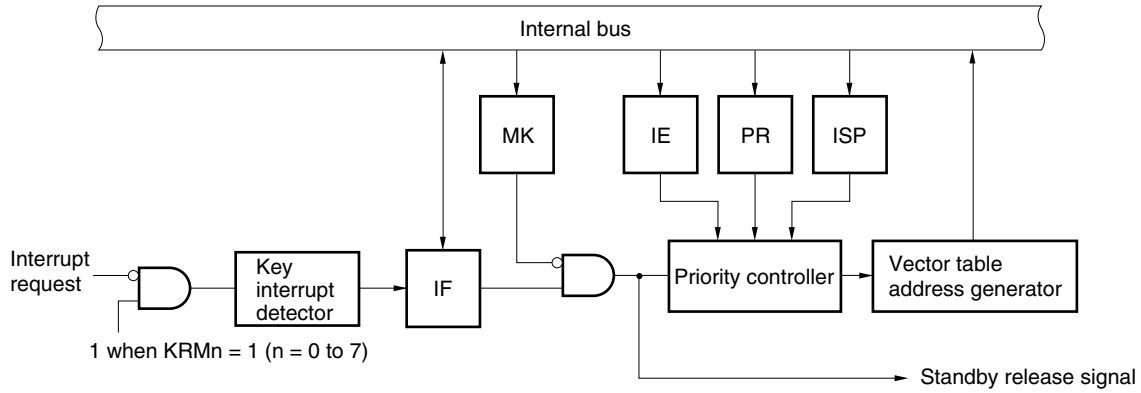

(D) Software interrupt

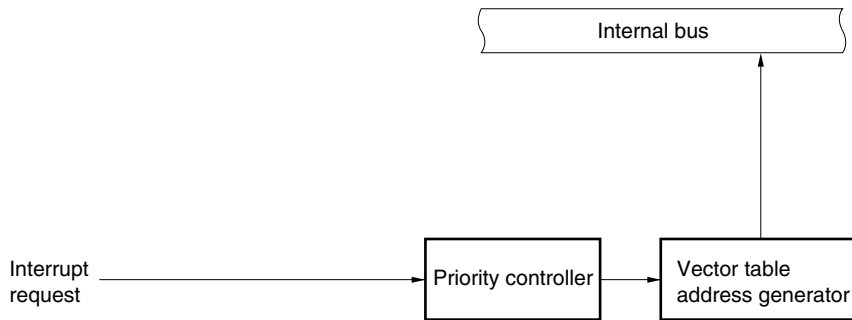

- IF: Interrupt request flag
- IE: Interrupt enable flag
- ISP: In-service priority flag
- MK: Interrupt mask flag
- PR: Priority specification flag
- KRM: Key return mode register

19.3 Registers Controlling Interrupt Functions

The following 6 types of registers are used to control the interrupt functions.

- Interrupt request flag register (IF0L, IF0H, IF1L, IF1H)
- Interrupt mask flag register (MK0L, MK0H, MK1L, MK1H)
- Priority specification flag register (PR0L, PR0H, PR1L, PR1H)
- External interrupt rising edge enable register (EGP)
- External interrupt falling edge enable register (EGN)
- Program status word (PSW)

Table 19-2 shows a list of interrupt request flags, interrupt mask flags, and priority specification flags corresponding to interrupt request sources.

Table 19-2. Flags Corresponding to Interrupt Request Sources

Interrupt Source	Interrupt Request Flag		Interrupt Mask Flag		Priority Specification Flag				
		Register		Register		Register			
INTLVI	LVIF	IF0L	LVIMK	MK0L	LVIPR	PR0L			
INTP0	PIF0		PMK0		PPR0				
INTP1	PIF1		PMK1		PPR1				
INTP2	PIF2		PMK2		PPR2				
INTP3	PIF3		PMK3		PPR3				
INTP4	PIF4		PMK4		PPR4				
INTP5	PIF5		PMK5		PPR5				
INTSRE6	SREIF6		SREMK6		SREPR6				
INTSR6	SRIF6	IF0H	SRMK6	MK0H	SRPR6	PR0H			
INTST6	STIF6		STMK6		STPR6				
INTCSI10	CSIF10		DUALIF0 <small>Note 1</small>		CSIMK10		DUALMK0 <small>Note 2</small>	CSIPR10	DUALPR0 <small>Note 2</small>
INTST0	STIF0				STMK0			STPR0	
INTTMH1	TMIFH1		TMMKH1		TMPRH1				
INTTMH0	TMIFH0		TMMKH0		TMPRH0				
INTTM50	TMIF50		TMMK50		TMPR50				
INTTM000	TMIF000		TMMK000		TMPR000				
INTTM010	TMIF010		TMMK010		TMPR010				
INTAD	ADIF		IF1L		ADMK		MK1L	ADPR	PR1L
INTSR0	SRIF0	SRMK0		SRPR0					
INTWTI	WTIF	WTIMK		WTIPR					
INTTM51	TMIF51	TMMK51		TMPR51					
INTKR	KRIF	KRMK		KRPR					
INTWT	WTIF	WTMK		WTPR					
INTP6	PIF6	PMK6		PPR6					
INTP7	PIF7	PMK7		PPR7					
INTIIC0	IICIF0	IF1H	IICMK0	MK1H	IICPR0	PR1H			
INTDMU ^{Note 3}	DMUIF ^{Note 3}		DMUMK ^{Note 3}		DMUPR ^{Note 3}				
INTCSI11 ^{Note 3}	CSIF11 ^{Note 3}		CSIMK11 ^{Note 3}		CSIPR11 ^{Note 3}				
INTTM001 ^{Note 3}	TMIF001 ^{Note 3}		TMMK001 ^{Note 3}		TMPR001 ^{Note 3}				
INTTM011 ^{Note 3}	TMIF011 ^{Note 3}		TMMK011 ^{Note 3}		TMPR011 ^{Note 3}				

- Notes**
1. If either interrupt source INTCSI10 or INTST0 is generated, these flags are set (1).
 2. Both interrupt sources INTCSI10 and INTST0 are supported.
 3. μ PD78F0534, 78F0535, 78F0536, 78F0537, and 78F0537D only.

(1) Interrupt request flag registers (IF0L, IF0H, IF1L, IF1H)

The interrupt request flags are set to 1 when the corresponding interrupt request is generated or an instruction is executed. They are cleared to 0 when an instruction is executed upon acknowledgment of an interrupt request or upon reset signal generation.

When an interrupt is acknowledged, the interrupt request flag is automatically cleared and then the interrupt routine is entered.

IF0L, IF0H, IF1L, and IF1H are set by a 1-bit or 8-bit memory manipulation instruction. When IF0L and IF0H, and IF1L and IF1H are combined to form 16-bit registers IF0 and IF1, they are set by a 16-bit memory manipulation instruction.

Reset signal generation sets these registers to 00H.

Figure 19-2. Format of Interrupt Request Flag Registers (IF0L, IF0H, IF1L, IF1H)

Address: FFE0H After reset: 00H R/W

Symbol	<7>	<6>	<5>	<4>	<3>	<2>	<1>	<0>
IF0L	SREIF6	PIF5	PIF4	PIF3	PIF2	PIF1	PIF0	LVIF

Address: FFE1H After reset: 00H R/W

Symbol	<7>	<6>	<5>	<4>	<3>	<2>	<1>	<0>
IF0H	TMIF010	TMIF000	TMIF50	TMIFH0	TMIFH1	DUALIF0 CSIIF10 STIF0	STIF6	SRIF6

Address: FFE2H After reset: 00H R/W

Symbol	<7>	<6>	<5>	<4>	<3>	<2>	<1>	<0>
IF1L	PIF7	PIF6	WTIF	KRIF	TMIF51	WTIIF	SRIF0	ADIF

Address: FFE3H After reset: 00H R/W

Symbol	7	6	5	4	<3>	<2>	<1>	<0>
IF1H	0	0	0	0	TMIF011 ^{Note}	TMIF001 ^{Note}	CSIIF11 ^{Note}	IICIF0 DMUIF ^{Note}

XXIFX	Interrupt request flag
0	No interrupt request signal is generated
1	Interrupt request is generated, interrupt request status

Note μ PD78F0534, 78F0535, 78F0536, 78F0537, and 78F0537D only.

- Cautions**
1. Be sure to clear bits 1 to 7 of IF1H to 0 for the μ PD78F0531, 78F0532, and 78F0533. Be sure to clear bits 4 to 7 of IF1H to 0 for the μ PD78F0534, 78F0535, 78F0536, 78F0537, and 78F0537D.
 2. When operating a timer, serial interface, or A/D converter after standby release, operate it once after clearing the interrupt request flag. An interrupt request flag may be set by noise.

Cautions 3. When manipulating a flag of the interrupt request flag register, use a 1-bit memory manipulation instruction (CLR1). When describing in C language, use a bit manipulation instruction such as “IF0L.0 = 0;” or “_asm(“clr1 IF0L, 0”);” because the compiled assembler must be a 1-bit memory manipulation instruction (CLR1).

If a program is described in C language using an 8-bit memory manipulation instruction such as “IF0L &= 0xfe;” and compiled, it becomes the assembler of three instructions.

```
mov a, IF0L
and a, #0FEH
mov IF0L, a
```

In this case, even if the request flag of another bit of the same interrupt request flag register (IF0L) is set to 1 at the timing between “mov a, IF0L” and “mov IF0L, a”, the flag is cleared to 0 at “mov IF0L, a”. Therefore, care must be exercised when using an 8-bit memory manipulation instruction in C language.

(2) Interrupt mask flag registers (MK0L, MK0H, MK1L, MK1H)

The interrupt mask flags are used to enable/disable the corresponding maskable interrupt servicing.

MK0L, MK0H, MK1L, and MK1H are set by a 1-bit or 8-bit memory manipulation instruction. When MK0L and MK0H, and MK1L and MK1H are combined to form 16-bit registers MK0 and MK1, they are set by a 16-bit memory manipulation instruction.

Reset signal generation sets these registers to FFH.

Figure 19-3. Format of Interrupt Mask Flag Registers (MK0L, MK0H, MK1L, MK1H)

Address: FFE4H After reset: FFH R/W

Symbol	<7>	<6>	<5>	<4>	<3>	<2>	<1>	<0>
MK0L	SREMK6	PMK5	PMK4	PMK3	PMK2	PMK1	PMK0	LVIMK

Address: FFE5H After reset: FFH R/W

Symbol	<7>	<6>	<5>	<4>	<3>	<2>	<1>	<0>
MK0H	TMMK010	TMMK000	TMMK50	TMMKH0	TMMKH1	DUALMK0 CSIMK0 STMK0	STMK6	SRMK6

Address: FFE6H After reset: FFH R/W

Symbol	<7>	<6>	<5>	<4>	<3>	<2>	<1>	<0>
MK1L	PMK7	PMK6	WTMK	KRMK	TMMK51	WTIMK	SRMK0	ADMK

Address: FFE7H After reset: FFH R/W

Symbol	7	6	5	4	<3>	<2>	<1>	<0>
MK1H	1	1	1	1	TMMK011 ^{Note}	TMMK001 ^{Note}	CSIMK11 ^{Note}	IICMK0 DMUMK ^{Note}

XXMKX	Interrupt servicing control
0	Interrupt servicing enabled
1	Interrupt servicing disabled

Note μ PD78F0534, 78F0535, 78F0536, 78F0537, and 78F0537D only.

Caution Be sure to set bits 1 to 7 of MK1H to 1 for the μ PD78F0531, 78F0532, and 78F0533. Be sure to set bits 4 to 7 of MK1H to 1 for the μ PD78F0534, 78F0535, 78F0536, 78F0537, and 78F0537D.

(3) Priority specification flag registers (PR0L, PR0H, PR1L, PR1H)

The priority specification flag registers are used to set the corresponding maskable interrupt priority order. PR0L, PR0H, PR1L, and PR1H are set by a 1-bit or 8-bit memory manipulation instruction. If PR0L and PR0H, and PR1L and PR1H are combined to form 16-bit registers PR0 and PR1, they are set by a 16-bit memory manipulation instruction.

Reset signal generation sets these registers to FFH.

Figure 19-4. Format of Priority Specification Flag Registers (PR0L, PR0H, PR1L, PR1H)

Address: FFE8H After reset: FFH R/W

Symbol	<7>	<6>	<5>	<4>	<3>	<2>	<1>	<0>
PR0L	SREPR6	PPR5	PPR4	PPR3	PPR2	PPR1	PPR0	LVIPR

Address: FFE9H After reset: FFH R/W

Symbol	<7>	<6>	<5>	<4>	<3>	<2>	<1>	<0>
PR0H	TMPR010	TMPR000	TMPR50	TMPRH0	TMPRH1	DUALPR0 CSIPR10 STPR0	STPR6	SRPR6

Address: FFEAH After reset: FFH R/W

Symbol	<7>	<6>	<5>	<4>	<3>	<2>	<1>	<0>
PR1L	PPR7	PPR6	WTPR	KRPR	TMPR51	WTIPR	SRPR0	ADPR

Address: FFE8H After reset: FFH R/W

Symbol	7	6	5	4	<3>	<2>	<1>	<0>
PR1H	1	1	1	1	TMPR011 ^{Note}	TMPR001 ^{Note}	CSIPR11 ^{Note}	IICPR0 DMUPR ^{Note}

XXPRX	Priority level selection
0	High priority level
1	Low priority level

Note μ PD78F0534, 78F0535, 78F0536, 78F0537, and 78F0537D only.

Caution Be sure to set bits 1 to 7 of PR1H to 1 for the μ PD78F0531, 78F0532, and 78F0533. Be sure to set bits 4 to 7 of PR1H to 1 for the μ PD78F0534, 78F0535, 78F0536, 78F0537, and 78F0537D.

(4) External interrupt rising edge enable register (EGP), external interrupt falling edge enable register (EGN)

These registers specify the valid edge for INTP0 to INTP7.

EGP and EGN are set by a 1-bit or 8-bit memory manipulation instruction.

Reset signal generation sets these registers to 00H.

Figure 19-5. Format of External Interrupt Rising Edge Enable Register (EGP) and External Interrupt Falling Edge Enable Register (EGN)

Address: FF48H After reset: 00H R/W

Symbol	7	6	5	4	3	2	1	0
EGP	EGP7	EGP6	EGP5	EGP4	EGP3	EGP2	EGP1	EGP0

Address: FF49H After reset: 00H R/W

Symbol	7	6	5	4	3	2	1	0
EGN	EGN7	EGN6	EGN5	EGN4	EGN3	EGN2	EGN1	EGN0

EGPn	EGNn	INTPn pin valid edge selection (n = 0 to 7)
0	0	Edge detection disabled
0	1	Falling edge
1	0	Rising edge
1	1	Both rising and falling edges

Table 19-3 shows the ports corresponding to EGPn and EGNn.

Table 19-3. Ports Corresponding to EGPn and EGNn

Detection Enable Register		Edge Detection Port	Interrupt Request Signal
EGP0	EGN0	P120	INTP0
EGP1	EGN1	P30	INTP1
EGP2	EGN2	P31	INTP2
EGP3	EGN3	P32	INTP3
EGP4	EGN4	P33	INTP4
EGP5	EGN5	P16	INTP5
EGP6	EGN6	P140	INTP6
EGP7	EGN7	P141	INTP7

Caution Select the port mode by clearing EGPn and EGNn to 0 because an edge may be detected when the external interrupt function is switched to the port function.

Remark n = 0 to 7

(5) Program status word (PSW)

The program status word is a register used to hold the instruction execution result and the current status for an interrupt request. The IE flag that sets maskable interrupt enable/disable and the ISP flag that controls multiple interrupt servicing are mapped to the PSW.

Besides 8-bit read/write, this register can carry out operations using bit manipulation instructions and dedicated instructions (EI and DI). When a vectored interrupt request is acknowledged, if the BRK instruction is executed, the contents of the PSW are automatically saved into a stack and the IE flag is reset to 0. If a maskable interrupt request is acknowledged, the contents of the priority specification flag of the acknowledged interrupt are transferred to the ISP flag. The PSW contents are also saved into the stack with the PUSH PSW instruction. They are restored from the stack with the RETI, RETB, and POP PSW instructions. Reset signal generation sets PSW to 02H.

Figure 19-6. Format of Program Status Word

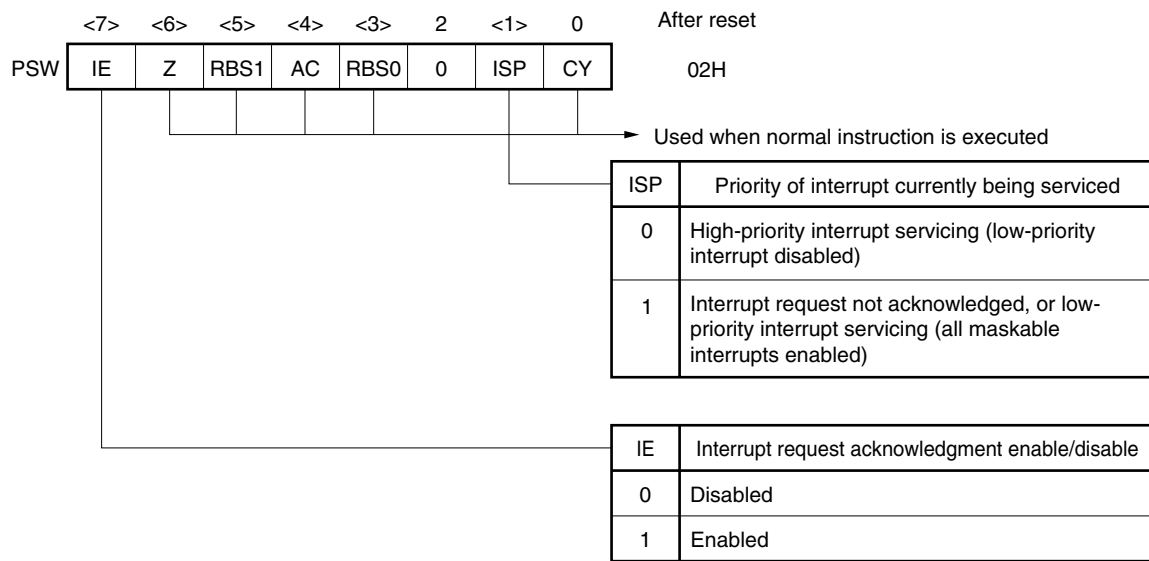

19.4 Interrupt Servicing Operations

19.4.1 Maskable interrupt acknowledgement

A maskable interrupt becomes acknowledgeable when the interrupt request flag is set to 1 and the mask (MK) flag corresponding to that interrupt request is cleared to 0. A vectored interrupt request is acknowledged if interrupts are in the interrupt enabled state (when the IE flag is set to 1). However, a low-priority interrupt request is not acknowledged during servicing of a higher priority interrupt request (when the ISP flag is reset to 0).

The times from generation of a maskable interrupt request until vectored interrupt servicing is performed are listed in Table 19-4 below.

For the interrupt request acknowledgement timing, see **Figures 19-8** and **19-9**.

Table 19-4. Time from Generation of Maskable Interrupt Until Servicing

	Minimum Time	Maximum Time ^{Note}
When $\times\times PR = 0$	7 clocks	32 clocks
When $\times\times PR = 1$	8 clocks	33 clocks

Note If an interrupt request is generated just before a divide instruction, the wait time becomes longer.

Remark 1 clock: $1/f_{CPU}$ (f_{CPU} : CPU clock)

If two or more maskable interrupt requests are generated simultaneously, the request with a higher priority level specified in the priority specification flag is acknowledged first. If two or more interrupts requests have the same priority level, the request with the highest default priority is acknowledged first.

An interrupt request that is held pending is acknowledged when it becomes acknowledgeable.

Figure 19-7 shows the interrupt request acknowledgement algorithm.

If a maskable interrupt request is acknowledged, the contents are saved into the stacks in the order of PSW, then PC, the IE flag is reset (0), and the contents of the priority specification flag corresponding to the acknowledged interrupt are transferred to the ISP flag. The vector table data determined for each interrupt request is the loaded into the PC and branched.

Restoring from an interrupt is possible by using the RETI instruction.

Figure 19-7. Interrupt Request Acknowledgement Processing Algorithm

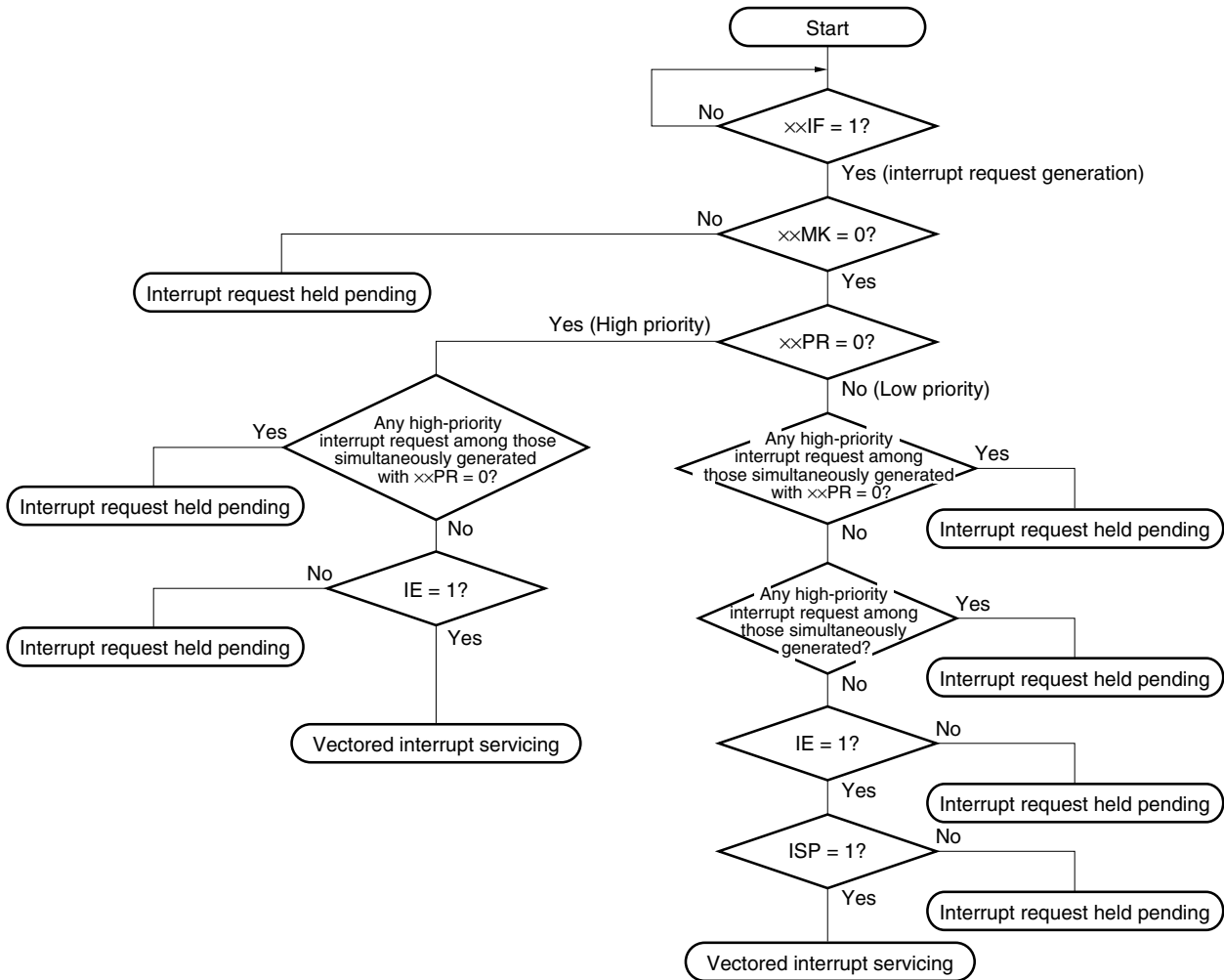

xxIF: Interrupt request flag

xxMK: Interrupt mask flag

xxPR: Priority specification flag

IE: Flag that controls acknowledgement of maskable interrupt request (1 = Enable, 0 = Disable)

ISP: Flag that indicates the priority level of the interrupt currently being serviced (0 = high-priority interrupt servicing, 1 = No interrupt request acknowledged, or low-priority interrupt servicing)

Figure 19-8. Interrupt Request Acknowledgement Timing (Minimum Time)

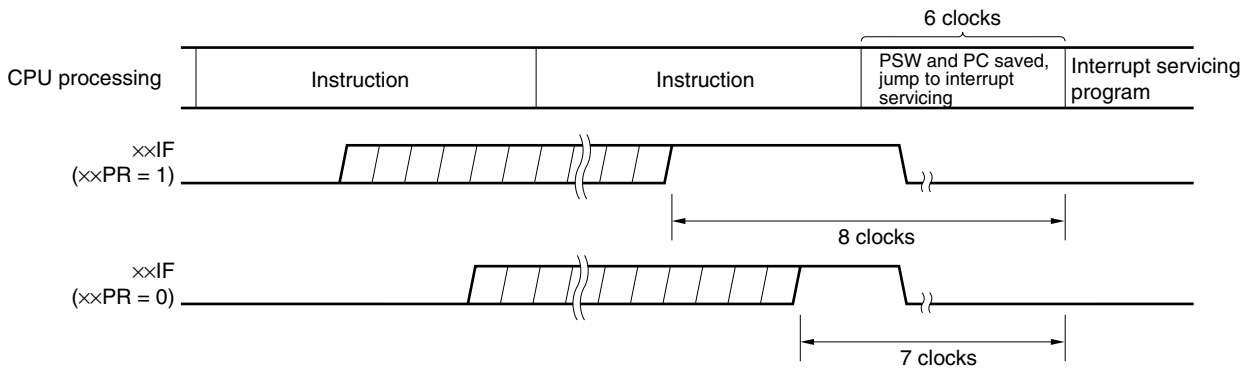

Remark 1 clock: $1/f_{CPU}$ (f_{CPU} : CPU clock)

Figure 19-9. Interrupt Request Acknowledgement Timing (Maximum Time)

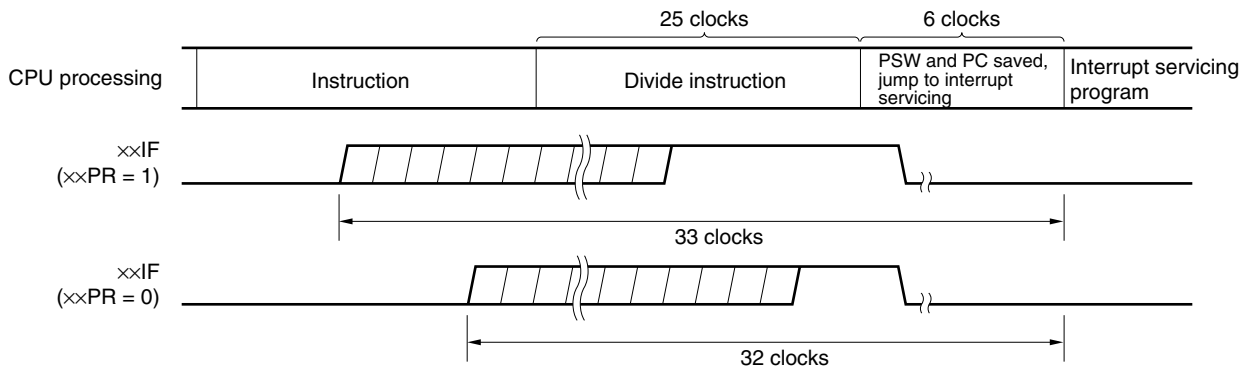

Remark 1 clock: $1/f_{CPU}$ (f_{CPU} : CPU clock)

19.4.2 Software interrupt request acknowledgement

A software interrupt acknowledge is acknowledged by BRK instruction execution. Software interrupts cannot be disabled.

If a software interrupt request is acknowledged, the contents are saved into the stacks in the order of the program status word (PSW), then program counter (PC), the IE flag is reset (0), and the contents of the vector table (003EH, 003FH) are loaded into the PC and branched.

Restoring from a software interrupt is possible by using the RETB instruction.

Caution Do not use the RETI instruction for restoring from the software interrupt.

19.4.3 Multiple interrupt servicing

Multiple interrupt servicing occurs when another interrupt request is acknowledged during execution of an interrupt.

Multiple interrupt servicing does not occur unless the interrupt request acknowledgement enabled state is selected (IE = 1). When an interrupt request is acknowledged, interrupt request acknowledgement becomes disabled (IE = 0). Therefore, to enable multiple interrupt servicing, it is necessary to set (1) the IE flag with the EI instruction during interrupt servicing to enable interrupt acknowledgement.

Moreover, even if interrupts are enabled, multiple interrupt servicing may not be enabled, this being subject to interrupt priority control. Two types of priority control are available: default priority control and programmable priority control. Programmable priority control is used for multiple interrupt servicing.

In the interrupt enabled state, if an interrupt request with a priority equal to or higher than that of the interrupt currently being serviced is generated, it is acknowledged for multiple interrupt servicing. If an interrupt with a priority lower than that of the interrupt currently being serviced is generated during interrupt servicing, it is not acknowledged for multiple interrupt servicing. Interrupt requests that are not enabled because interrupts are in the interrupt disabled state or because they have a lower priority are held pending. When servicing of the current interrupt ends, the pending interrupt request is acknowledged following execution of at least one main processing instruction execution.

Table 19-5 shows relationship between interrupt requests enabled for multiple interrupt servicing and Figure 19-10 shows multiple interrupt servicing examples.

Table 19-5. Relationship Between Interrupt Requests Enabled for Multiple Interrupt Servicing During Interrupt Servicing

Multiple Interrupt Request Interrupt Being Serviced		Maskable Interrupt Request				Software Interrupt Request
		PR = 0		PR = 1		
		IE = 1	IE = 0	IE = 1	IE = 0	
Maskable interrupt	ISP = 0	○	×	×	×	○
	ISP = 1	○	×	○	×	○
Software interrupt		○	×	○	×	○

- Remarks**
- : Multiple interrupt servicing enabled
 - ×: Multiple interrupt servicing disabled
 - ISP and IE are flags contained in the PSW.
 - ISP = 0: An interrupt with higher priority is being serviced.
 - ISP = 1: No interrupt request has been acknowledged, or an interrupt with a lower priority is being serviced.
 - IE = 0: Interrupt request acknowledgement is disabled.
 - IE = 1: Interrupt request acknowledgement is enabled.
 - PR is a flag contained in PR0L, PR0H, PR1L, and PR1H.
 - PR = 0: Higher priority level
 - PR = 1: Lower priority level

Figure 19-10. Examples of Multiple Interrupt Servicing (1/2)

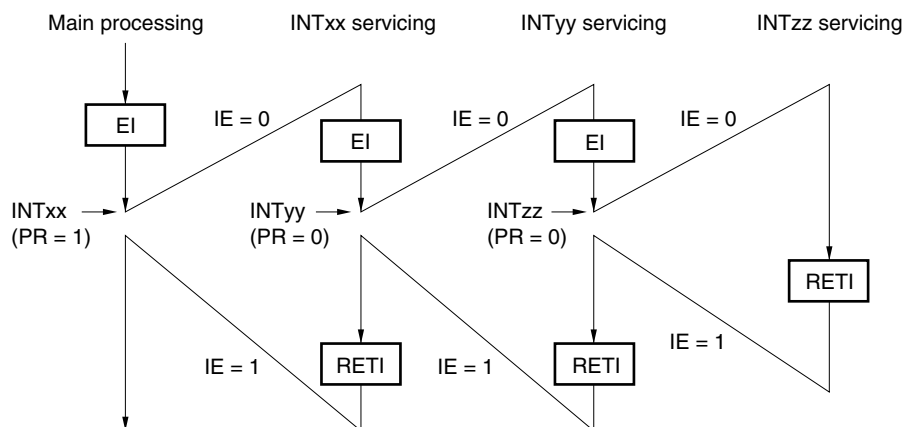
Example 1. Multiple interrupt servicing occurs twice

During servicing of interrupt INTxx, two interrupt requests, INTyy and INTzz, are acknowledged, and multiple interrupt servicing takes place. Before each interrupt request is acknowledged, the EI instruction must always be issued to enable interrupt request acknowledgment.

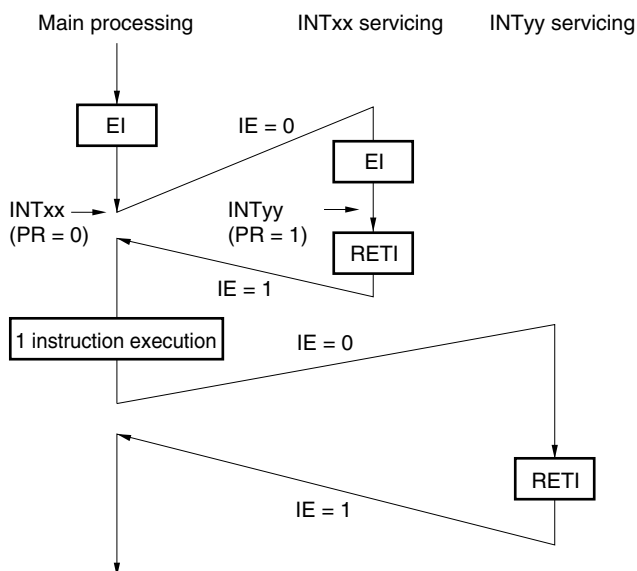
Example 2. Multiple interrupt servicing does not occur due to priority control

Interrupt request INTyy issued during servicing of interrupt INTxx is not acknowledged because its priority is lower than that of INTxx, and multiple interrupt servicing does not take place. The INTyy interrupt request is held pending, and is acknowledged following execution of one main processing instruction.

PR = 0: Higher priority level

PR = 1: Lower priority level

IE = 0: Interrupt request acknowledgment disabled

Figure 19-10. Examples of Multiple Interrupt Servicing (2/2)

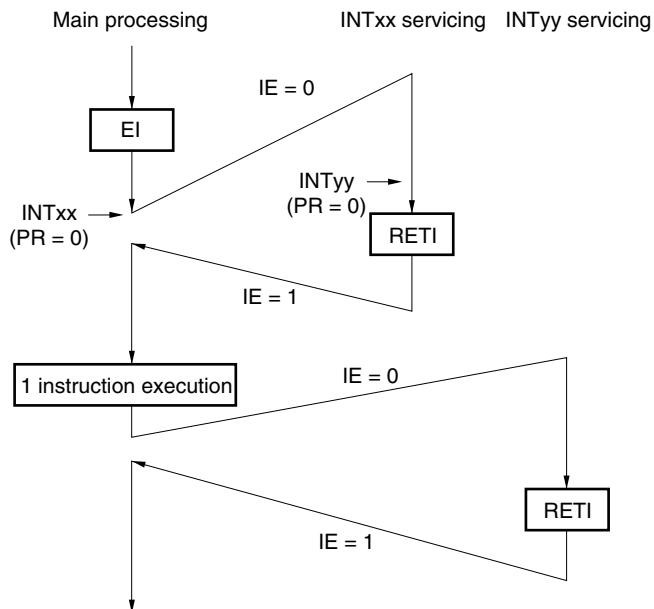
Example 3. Multiple interrupt servicing does not occur because interrupts are not enabled

Interrupts are not enabled during servicing of interrupt INTxx (EI instruction is not issued), therefore, interrupt request INTyy is not acknowledged and multiple interrupt servicing does not take place. The INTyy interrupt request is held pending, and is acknowledged following execution of one main processing instruction.

PR = 0: Higher priority level

IE = 0: Interrupt request acknowledgement disabled

19.4.4 Interrupt request hold

There are instructions where, even if an interrupt request is issued for them while another instruction is being executed, request acknowledgement is held pending until the end of execution of the next instruction. These instructions (interrupt request hold instructions) are listed below.

- MOV PSW, #byte
- MOV A, PSW
- MOV PSW, A
- MOV1 PSW. bit, CY
- MOV1 CY, PSW. bit
- AND1 CY, PSW. bit
- OR1 CY, PSW. bit
- XOR1 CY, PSW. bit
- SET1 PSW. bit
- CLR1 PSW. bit
- RETB
- RETI
- PUSH PSW
- POP PSW
- BT PSW. bit, \$addr16
- BF PSW. bit, \$addr16
- BTCLR PSW. bit, \$addr16
- EI
- DI
- Manipulation instructions for the IF0L, IF0H, IF1L, IF1H, MK0L, MK0H, MK1L, MK1H, PR0L, PR0H, PR1L, and PR1H registers.

Caution The BRK instruction is not one of the above-listed interrupt request hold instructions. However, the software interrupt activated by executing the BRK instruction causes the IE flag to be cleared. Therefore, even if a maskable interrupt request is generated during execution of the BRK instruction, the interrupt request is not acknowledged.

Figure 19-11 shows the timing at which interrupt requests are held pending.

Figure 19-11. Interrupt Request Hold

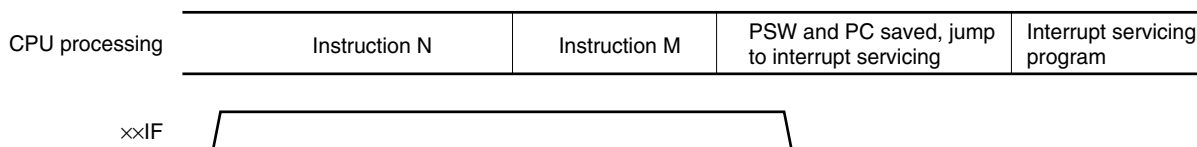

- Remarks**
1. Instruction N: Interrupt request hold instruction
 2. Instruction M: Instruction other than interrupt request hold instruction
 3. The $\times\times$ PR (priority level) values do not affect the operation of $\times\times$ IF (interrupt request).

CHAPTER 20 KEY INTERRUPT FUNCTION

20.1 Functions of Key Interrupt

A key interrupt (INTKR) can be generated by setting the key return mode register (KRM) and inputting a falling edge to the key interrupt input pins (KR0 to KR7).

Table 20-1. Assignment of Key Interrupt Detection Pins

Flag	Description
KRM0	Controls KR0 signal in 1-bit units.
KRM1	Controls KR1 signal in 1-bit units.
KRM2	Controls KR2 signal in 1-bit units.
KRM3	Controls KR3 signal in 1-bit units.
KRM4	Controls KR4 signal in 1-bit units.
KRM5	Controls KR5 signal in 1-bit units.
KRM6	Controls KR6 signal in 1-bit units.
KRM7	Controls KR7 signal in 1-bit units.

20.2 Configuration of Key Interrupt

The key interrupt includes the following hardware.

Table 20-2. Configuration of Key Interrupt

Item	Configuration
Control register	Key return mode register (KRM)

Figure 20-1. Block Diagram of Key Interrupt

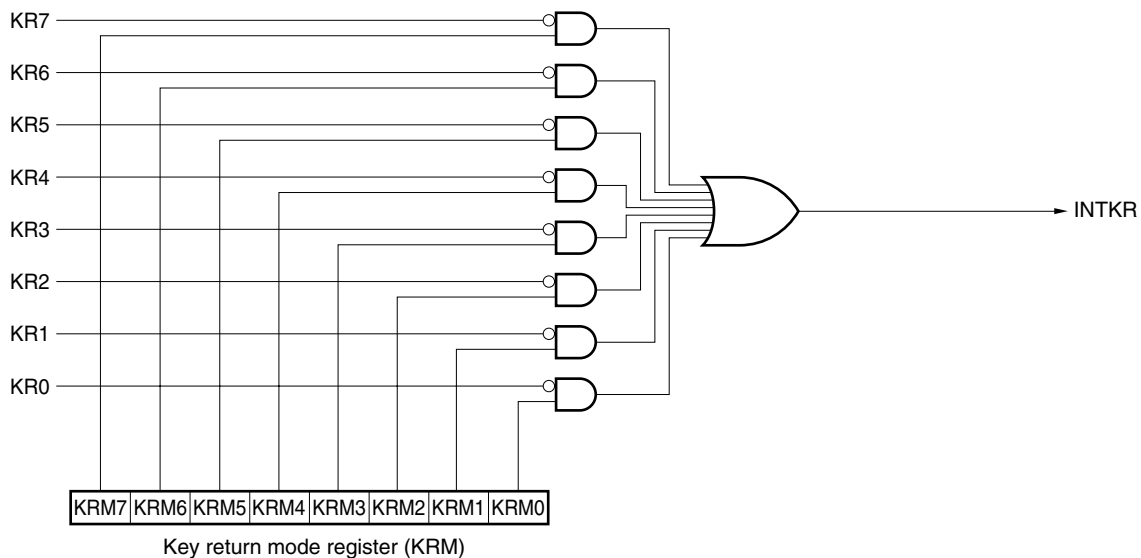

20.3 Register Controlling Key Interrupt

(1) Key return mode register (KRM)

This register controls the KRM0 to KRM7 bits using the KR0 to KR7 signals, respectively.

KRM is set by a 1-bit or 8-bit memory manipulation instruction.

Reset signal generation sets KRM to 00H.

Figure 20-2. Format of Key Return Mode Register (KRM)

Address: FF6EH After reset: 00H R/W

Symbol	7	6	5	4	3	2	1	0
KRM	KRM7	KRM6	KRM5	KRM4	KRM3	KRM2	KRM1	KRM0

KRMn	Key interrupt mode control
0	Does not detect key interrupt signal
1	Detects key interrupt signal

- Cautions**
1. If any of the KRM0 to KRM7 bits used is set to 1, set bits 0 to 7 (PU70 to PU77) of the corresponding pull-up resistor register 7 (PU7) to 1.
 2. If KRM is changed, the interrupt request flag may be set. Therefore, disable interrupts and then change the KRM register. Clear the interrupt request flag and enable interrupts.
 3. The bits not used in the key interrupt mode can be used as normal ports.

CHAPTER 21 STANDBY FUNCTION

21.1 Standby Function and Configuration

21.1.1 Standby function

The standby function is designed to reduce the operating current of the system. The following two modes are available.

(1) HALT mode

HALT instruction execution sets the HALT mode. In the HALT mode, the CPU operation clock is stopped. If the high-speed system clock oscillator, internal high-speed oscillator, internal low-speed oscillator, or subsystem clock oscillator is operating before the HALT mode is set, oscillation of each clock continues. In this mode, the operating current is not decreased as much as in the STOP mode, but the HALT mode is effective for restarting operation immediately upon interrupt request generation and carrying out intermittent operations frequently.

(2) STOP mode

STOP instruction execution sets the STOP mode. In the STOP mode, the high-speed system clock oscillator and internal high-speed oscillator stop, stopping the whole system, thereby considerably reducing the CPU operating current.

Because this mode can be cleared by an interrupt request, it enables intermittent operations to be carried out. However, because a wait time is required to secure the oscillation stabilization time after the STOP mode is released when the X1 clock is selected, select the HALT mode if it is necessary to start processing immediately upon interrupt request generation.

In either of these two modes, all the contents of registers, flags and data memory just before the standby mode is set are held. The I/O port output latches and output buffer statuses are also held.

Cautions 1. The STOP mode can be used only when the CPU is operating on the main system clock. The subsystem clock oscillation cannot be stopped. The HALT mode can be used when the CPU is operating on either the main system clock or the subsystem clock.

2. When shifting to the STOP mode, be sure to stop the peripheral hardware operation operating with main system clock before executing STOP instruction.

★ 3. The following sequence is recommended for operating current reduction of the A/D converter when the standby function is used: First clear bit 7 (ADCS) and bit 0 (ADCE) of the A/D converter mode register (ADM) to 0 to stop the A/D conversion operation, and then execute the STOP instruction.

21.1.2 Registers controlling standby function

The standby function is controlled by the following two registers.

- Oscillation stabilization time counter status register (OSTC)
- Oscillation stabilization time select register (OSTS)

Remark For the registers that start, stop, or select the clock, see **CHAPTER 6 CLOCK GENERATOR**.

(1) Oscillation stabilization time counter status register (OSTC)

This is the register that indicates the count status of the X1 clock oscillation stabilization time counter. When X1 clock oscillation starts with the internal high-speed oscillation clock or subsystem clock used as the CPU clock, the X1 clock oscillation stabilization time can be checked.

OSTC can be read by a 1-bit or 8-bit memory manipulation instruction.

When reset is released (reset by $\overline{\text{RESET}}$ input, POC, LVI, and WDT), the STOP instruction and MSTOP (bit 7 of MOC register) = 1 clear OSTC to 00H.

Figure 21-1. Format of Oscillation Stabilization Time Counter Status Register (OSTC)

Address: FFA3H After reset: 00H R

Symbol	7	6	5	4	3	2	1	0
OSTC	0	0	0	MOST11	MOST13	MOST14	MOST15	MOST16

MOST11	MOST13	MOST14	MOST15	MOST16	Oscillation stabilization time status	
					$f_x = 10 \text{ MHz}$	$f_x = 20 \text{ MHz}$
1	0	0	0	0	$2^{11}/f_x \text{ min.}$	204.8 μs min. / 102.4 μs min.
1	1	0	0	0	$2^{13}/f_x \text{ min.}$	819.2 μs min. / 409.6 μs min.
1	1	1	0	0	$2^{14}/f_x \text{ min.}$	1.64 ms min. / 819.2 μs min.
1	1	1	1	0	$2^{15}/f_x \text{ min.}$	3.27 ms min. / 1.64 ms min.
1	1	1	1	1	$2^{16}/f_x \text{ min.}$	6.55 ms min. / 3.27 ms min.

- Cautions**
- After the above time has elapsed, the bits are set to 1 in order from MOST11 and remain 1.
 - The oscillation stabilization time counter counts up to the oscillation stabilization time set by OSTC. If the STOP mode is entered and then released while the internal high-speed oscillation clock is being used as the CPU clock, set the oscillation stabilization time as follows.
 - Desired OSTC oscillation stabilization time \leq Oscillation stabilization time set by OSTC

Note, therefore, that only the status up to the oscillation stabilization time set by OSTC is set to OSTC after STOP mode is released.
 - The X1 clock oscillation stabilization wait time does not include the time until clock oscillation starts (“a” below).

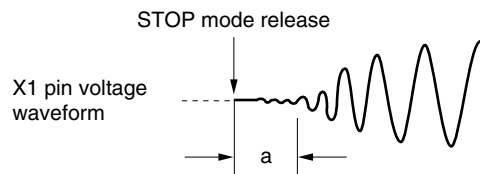

Remark f_x : X1 clock oscillation frequency

(2) Oscillation stabilization time select register (OSTS)

This register is used to select the X1 clock oscillation stabilization wait time when the STOP mode is released. When the X1 clock is selected as the CPU clock, the operation waits for the time set using OSTS after the STOP mode is released.

- ★ When the internal high-speed oscillation clock is selected as the CPU clock, confirm with OSTC that the desired oscillation stabilization time has elapsed after the STOP mode is released. The oscillation stabilization time can be checked up to the time set using OSTC. OSTS can be set by an 8-bit memory manipulation instruction. Reset signal generation sets OSTS to 05H.

Figure 21-2. Format of Oscillation Stabilization Time Select Register (OSTS)

Address: FFA4H After reset: 05H R/W

Symbol	7	6	5	4	3	2	1	0
OSTS	0	0	0	0	0	OSTS2	OSTS1	OSTS0

OSTS2	OSTS1	OSTS0	Oscillation stabilization time selection		
				fx = 10 MHz	fx = 20 MHz
0	0	1	$2^{11}/f_x$	204.8 μ s	102.4 μ s
0	1	0	$2^{13}/f_x$	819.2 μ s	409.6 μ s
0	1	1	$2^{14}/f_x$	1.64 ms	819.2 μ s
1	0	0	$2^{15}/f_x$	3.27 ms	1.64 ms
1	0	1	$2^{16}/f_x$	6.55 ms	3.27 ms
Other than above			Setting prohibited		

- Cautions**
1. To set the STOP mode when the X1 clock is used as the CPU clock, set OSTS before executing the STOP instruction.
 2. Do not change the value of the OSTS register during the X1 clock oscillation stabilization time.
 3. The oscillation stabilization time counter counts up to the oscillation stabilization time set by OSTS. If the STOP mode is entered and then released while the internal high-speed oscillation clock is being used as the CPU clock, set the oscillation stabilization time as follows.
 - Desired OSTC oscillation stabilization time \leq Oscillation stabilization time set by OSTS

Note, therefore, that only the status up to the oscillation stabilization time set by OSTS is set to OSTC after STOP mode is released.
 4. The X1 clock oscillation stabilization wait time does not include the time until clock oscillation starts (“a” below).

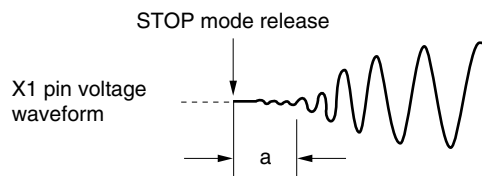

Remark fx: X1 clock oscillation frequency

21.2 Standby Function Operation

21.2.1 HALT mode

(1) HALT mode

The HALT mode is set by executing the HALT instruction. HALT mode can be set regardless of whether the CPU clock before the setting was the high-speed system clock, internal high-speed oscillation clock, or subsystem clock.

The operating statuses in the HALT mode are shown below.

Table 21-1. Operating Statuses in HALT Mode (1/2)

HALT Mode Setting		When HALT Instruction Is Executed While CPU Is Operating on Main System Clock					
		When CPU Is Operating on Internal High-Speed Oscillation Clock (f_{RH})	When CPU Is Operating on X1 Clock (f_x)	When CPU Is Operating on External Main System Clock (f_{EXCLK})			
Item							
System clock		Clock supply to the CPU is stopped					
Main system clock	f_{RH}	Operation continues (cannot be stopped)	Status before HALT mode was set is retained				
	f_x	Status before HALT mode was set is retained	Operation continues (cannot be stopped)	Status before HALT mode was set is retained			
	f_{EXCLK}	Operates or stops by external clock input		Operation continues (cannot be stopped)			
Subsystem clock	f_{XT}	Status before HALT mode was set is retained					
	f_{EXCLKS}	Operates or stops by external clock input					
f_{RL}		Status before HALT mode was set is retained					
CPU		Operation stopped					
Flash memory		Operation stopped					
RAM		Status before HALT mode was set is retained					
Port (latch)		Status before HALT mode was set is retained					
16-bit timer/event counter	00	Operable					
	01 ^{Note}						
8-bit timer/event counter	50						
	51						
8-bit timer	H0						
	H1						
Watch timer		Operable					
Watchdog timer					Operable. Clock supply to watchdog timer stops when "internal low-speed oscillator can be stopped by software" is set by option byte.		
★ Clock output					Operable		
★ Buzzer output							
A/D converter							
Serial interface	UART0						
	UART6						
	CSI10						
	CSI11 ^{Note}						
	IIC0						
Multiplier/divider ^{Note}							
Power-on-clear function							
Low-voltage detection function							
External interrupt							

Note μ PD78F0534, 78F0535, 78F0536, 78F0537, and 78F0537D only.

Remark f_{RH} : Internal high-speed oscillation clock
 f_x : X1 clock
 f_{EXCLK} : External main system clock
 f_{XT} : XT1 clock
 f_{EXCLKS} : External subsystem clock
 f_{RL} : Internal low-speed oscillation clock

Table 21-1. Operating Statuses in HALT Mode (2/2)

HALT Mode Setting		When HALT Instruction Is Executed While CPU Is Operating on Subsystem Clock			
		When CPU Is Operating on XT1 Clock (f _{XT})	When CPU Is Operating on External Subsystem Clock (f _{EXCLKS})		
System clock		Clock supply to the CPU is stopped			
Main system clock	f _{RH}	Status before HALT mode was set is retained			
	f _X				
	f _{EXCLK}	Operates or stops by external clock input			
Subsystem clock	f _{XT}	Operation continues (cannot be stopped)	Status before HALT mode was set is retained		
	f _{EXCLKS}	Operates or stops by external clock input	Operation continues (cannot be stopped)		
f _{RL}		Status before HALT mode was set is retained			
CPU		Operation stopped			
Flash memory		Operation stopped			
RAM		Status before HALT mode was set is retained			
Port (latch)		Status before HALT mode was set is retained			
16-bit timer/event counter	00 ^{Note1}	Operable			
	01 ^{Note1, 2}				
8-bit timer/event counter	50 ^{Note1}				
	51 ^{Note1}				
8-bit timer	H0				
	H1				
Watch timer					
Watchdog timer				Operable. Clock supply to watchdog timer stops when “internal low-speed oscillator can be stopped by software” is set by option byte.	
Clock output		Operable			
Buzzer output		Operable. However, operation disabled when peripheral hardware clock (f _{PRS}) is stopped.			
A/D converter					
Serial interface	UART0	Operable			
	UART6				
	CSI10 ^{Note1}				
	CSI11 ^{Note1, 2}				
	IIC0 ^{Note1}				
Multiplier/divider ^{Note2}					
Power-on-clear function					
Low-voltage detection function					
External interrupt					

★
★

- ★ **Notes 1.** When the CPU is operating on the subsystem clock and the internal high-speed oscillation clock has been stopped, do not start operation of these functions on the external clock input from peripheral hardware pins.
2. μ PD78F0534, 78F0535, 78F0536, 78F0537, and 78F0537D only.

Remark f_{RH}: Internal high-speed oscillation clock
 f_X: X1 clock
 f_{EXCLK}: External main system clock
 f_{XT}: XT1 clock
 f_{EXCLKS}: External subsystem clock
 f_{RL}: Internal low-speed oscillation clock

(2) HALT mode release

The HALT mode can be released by the following two sources.

(a) Release by unmasked interrupt request

When an unmasked interrupt request is generated, the HALT mode is released. If interrupt acknowledgement is enabled, vectored interrupt servicing is carried out. If interrupt acknowledgement is disabled, the next address instruction is executed.

Figure 21-3. HALT Mode Release by Interrupt Request Generation

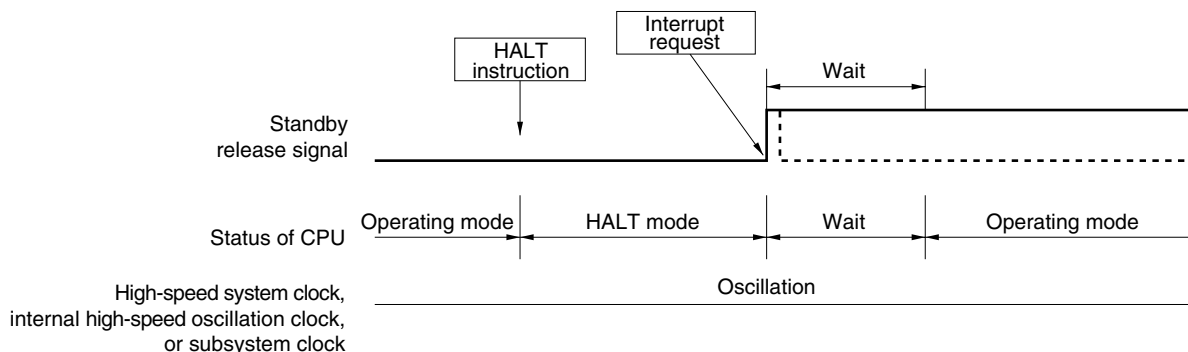

Remarks 1. The broken lines indicate the case when the interrupt request which has released the standby mode is acknowledged.

2. The wait time is as follows:

- When vectored interrupt servicing is carried out: 8 or 9 clocks
- When vectored interrupt servicing is not carried out: 2 or 3 clocks

(b) Release by reset signal generation

When the reset signal is generated, HALT mode is released, and then, as in the case with a normal reset operation, the program is executed after branching to the reset vector address.

★

Figure 21-4. HALT Mode Release by Reset

(1) When high-speed system clock is used as CPU clock

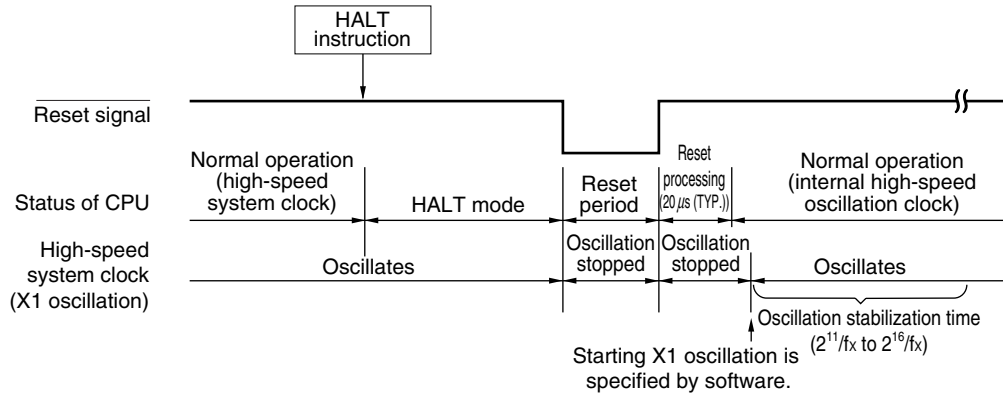

(2) When internal high-speed oscillation clock is used as CPU clock

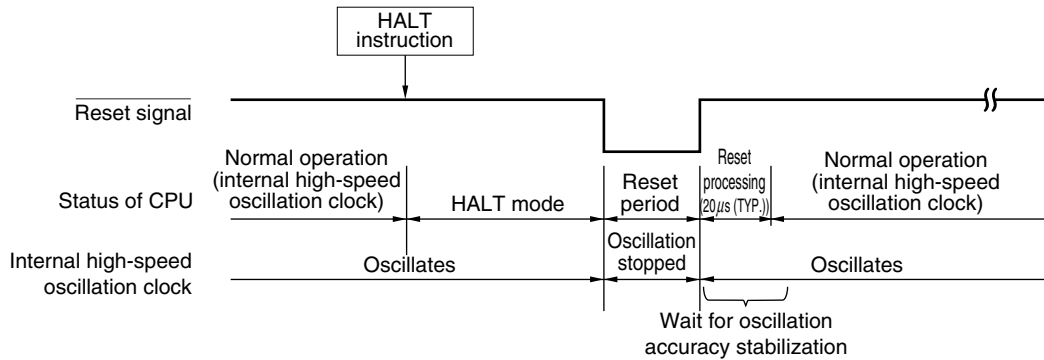

(3) When subsystem clock is used as CPU clock

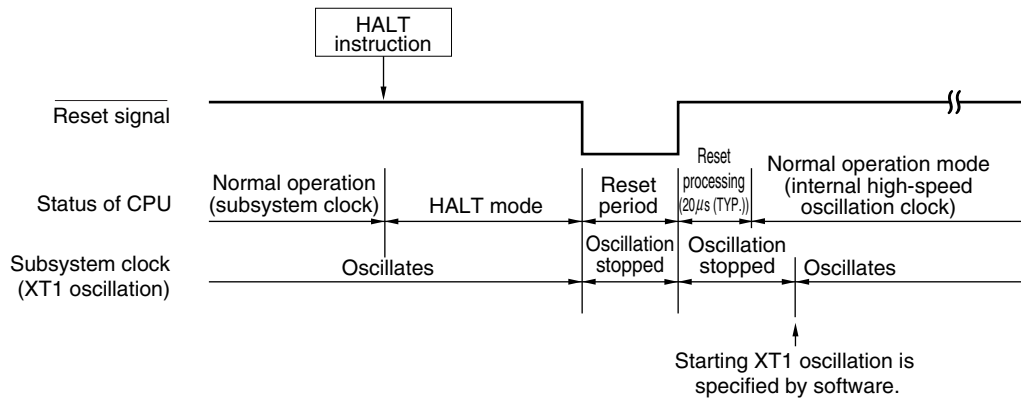

Remark f_x : X1 clock oscillation frequency

Table 21-2. Operation in Response to Interrupt Request in HALT Mode

Release Source	MK _{xx}	PR _{xx}	IE	ISP	Operation
Maskable interrupt request	0	0	0	×	Next address instruction execution
	0	0	1	×	Interrupt servicing execution
	0	1	0	1	Next address instruction execution
	0	1	×	0	
	0	1	1	1	Interrupt servicing execution
	1	×	×	×	HALT mode held
Reset	–	–	×	×	Reset processing

×: don't care

21.2.2 STOP mode

(1) STOP mode setting and operating statuses

The STOP mode is set by executing the STOP instruction, and it can be set only when the CPU clock before the setting was the main system clock.

Caution Because the interrupt request signal is used to clear the standby mode, if there is an interrupt source with the interrupt request flag set and the interrupt mask flag reset, the standby mode is immediately cleared if set. Thus, the STOP mode is reset to the HALT mode immediately after execution of the STOP instruction and the system returns to the operating mode as soon as the wait time set using the oscillation stabilization time select register (OSTS) has elapsed.

The operating statuses in the STOP mode are shown below.

Table 21-3. Operating Statuses in STOP Mode

STOP Mode Setting		When STOP Instruction Is Executed While CPU Is Operating on Main System Clock		
		When CPU Is Operating on Internal High-Speed Oscillation Clock (f _{RH})	When CPU Is Operating on X1 Clock (fx)	When CPU Is Operating on External Main System Clock (f _{EXCLK})
Item				
System clock		Clock supply to the CPU is stopped		
Main system clock	f _{RH}	Stopped		
	fx			
	f _{EXCLK}	Input invalid		
Subsystem clock	f _{XT}	Status before STOP mode was set is retained		
	f _{EXCLKS}	Operates or stops by external clock input		
f _{RL}		Status before STOP mode was set is retained		
CPU		Operation stopped		
Flash memory		Operation stopped		
RAM		Status before STOP mode was set is retained		
Port (latch)		Status before STOP mode was set is retained		
16-bit timer/event counter	00	Operation stopped		
	01 ^{Note}			
8-bit timer/event counter	50	Operable only when TI50 is selected as the count clock		
	51	Operable only when TI51 is selected as the count clock		
8-bit timer	H0	Operable only when TM50 output is selected as the count clock during 8-bit timer/event counter 50 operation		
	H1	Operable only when f _{RL} , f _{RL} /2 ⁷ , f _{RL} /2 ⁹ is selected as the count clock		
Watch timer		Operable only when subsystem clock is selected as the count clock		
Watchdog timer		Operable. Clock supply to watchdog timer stops when “internal low-speed oscillator can be stopped by software” is set by option byte.		
★ Clock output		Operable only when subsystem clock is selected as the count clock		
★ Buzzer output		Operation stopped		
A/D converter				
Serial interface	UART0	Operable only when TM50 output is selected as the serial clock during 8-bit timer/event counter 50 operation		
	UART6			
	CSI10	Operable only when external clock is selected as the serial clock		
	CSI11 ^{Note}			
	IIC0			
Multiplier/divider ^{Note2}		Operation stopped		
Power-on-clear function		Operable		
Low-voltage detection function				
External interrupt				

Note μ PD78F0534, 78F0535, 78F0536, 78F0537, and 78F0537D only.

Remark f_{RH}: Internal high-speed oscillation clock
fx: X1 clock
f_{EXCLK}: External main system clock
f_{XT}: XT1 clock
f_{EXCLKS}: External subsystem clock
f_{RL}: Internal low-speed oscillation clock

- Cautions**
1. To use the peripheral hardware that stops operation in the STOP mode, and the peripheral hardware for which the clock that stops oscillating in the STOP mode after the STOP mode is released, restart the peripheral hardware.
 2. Even if “internal low-speed oscillator can be stopped by software” is selected by the option byte, the internal low-speed oscillation clock continues in the STOP mode in the status before the STOP mode is set. To stop the internal low-speed oscillator’s oscillation in the STOP mode, stop it by software and then execute the STOP instruction.
 3. To shorten oscillation stabilization time after the STOP mode is released when the CPU operates with the high-speed system clock (X1 oscillation), temporarily switch the CPU clock to the internal high-speed oscillation clock before the next execution of the STOP instruction. Before changing the CPU clock from the internal high-speed oscillation clock to the high-speed system clock after the STOP mode is released, check the oscillation stabilization time with the oscillation stabilization time counter status register (OSTC).
 4. If the STOP instruction is executed with AMPH set to 1 when the internal high-speed oscillation clock or external main system clock is used as the CPU clock, the internal high-speed oscillation clock or external main system clock is supplied to the CPU 5 μs (MIN.) after the STOP mode has been released.

(2) STOP mode release

★

Figure 21-5. Operation Timing When STOP Mode Is Released

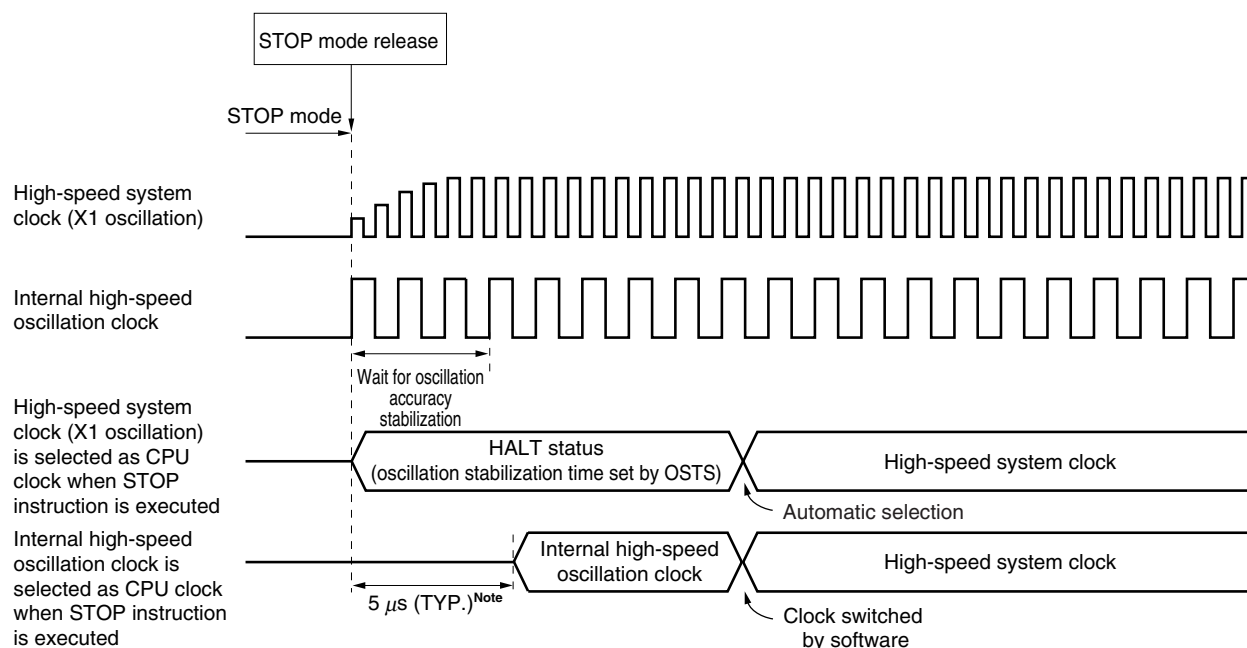

Note When AMPH = 1

The STOP mode can be released by the following two sources.

(a) Release by unmasked interrupt request

When an unmasked interrupt request is generated, the STOP mode is released. After the oscillation stabilization time has elapsed, if interrupt acknowledgment is enabled, vectored interrupt servicing is carried out. If interrupt acknowledgment is disabled, the next address instruction is executed.

Figure 21-6. STOP Mode Release by Interrupt Request Generation

(1) When high-speed system clock is used as CPU clock

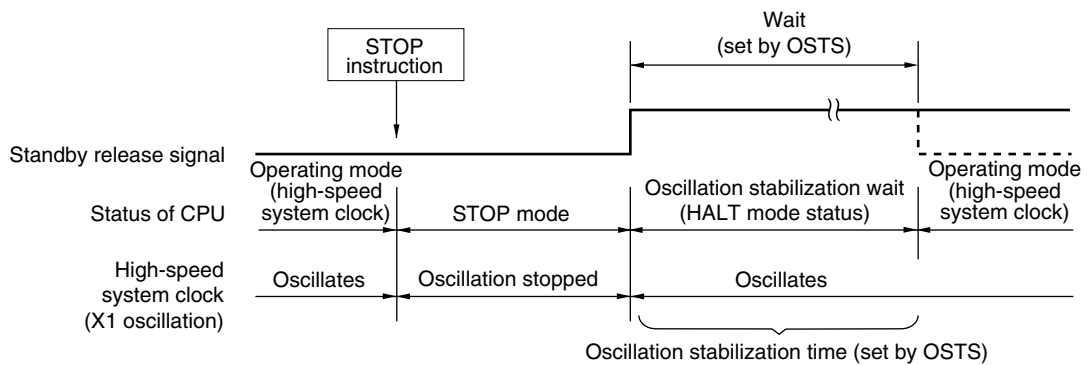

(2) When internal high-speed oscillation clock is used as CPU clock

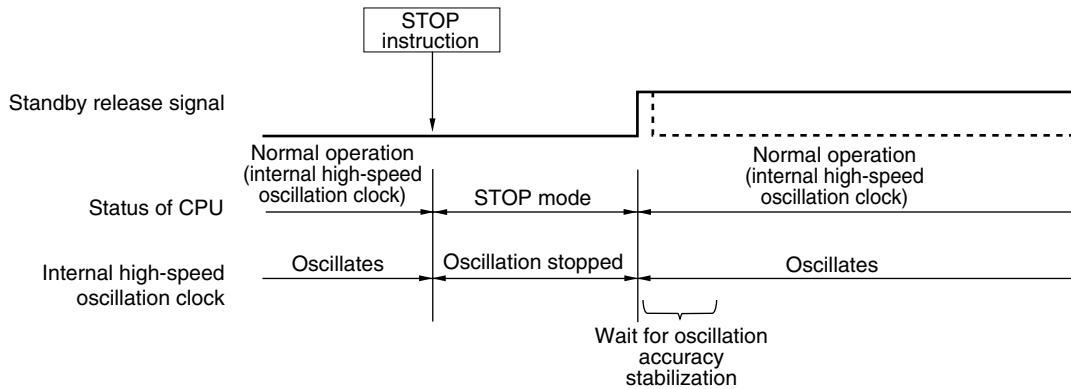

Remark The broken lines indicate the case when the interrupt request that has released the standby mode is acknowledged.

(b) Release by reset signal generation

When the reset signal is generated, STOP mode is released, and then, as in the case with a normal reset operation, the program is executed after branching to the reset vector address.

★

Figure 21-7. STOP Mode Release by Reset

(1) When high-speed system clock is used as CPU clock

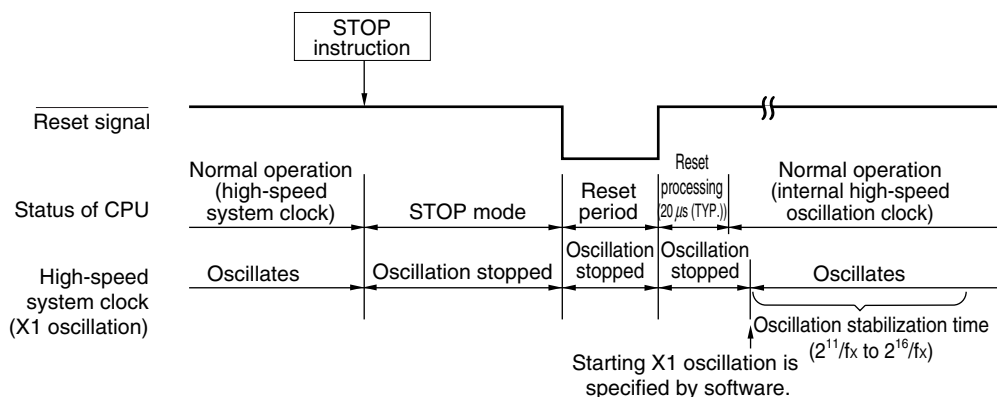

(2) When internal high-speed oscillation clock is used as CPU clock

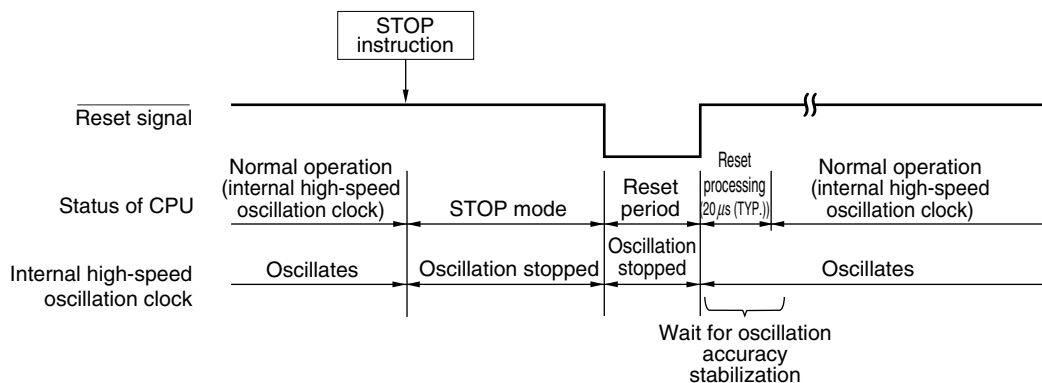

Remark fx: X1 clock oscillation frequency

Table 21-4. Operation in Response to Interrupt Request in STOP Mode

Release Source	MKxx	PRxx	IE	ISP	Operation
Maskable interrupt request	0	0	0	×	Next address instruction execution
	0	0	1	×	Interrupt servicing execution
	0	1	0	1	Next address instruction execution
	0	1	×	0	
	0	1	1	1	Interrupt servicing execution
	1	×	×	×	STOP mode held
Reset	–	–	×	×	Reset processing

×: don't care

CHAPTER 22 RESET FUNCTION

The following four operations are available to generate a reset signal.

- (1) External reset input via $\overline{\text{RESET}}$ pin
- (2) Internal reset by watchdog timer program loop detection
- (3) Internal reset by comparison of supply voltage and detection voltage of power-on-clear (POC) circuit
- (4) Internal reset by comparison of supply voltage and detection voltage of low-power-supply detector (LVI)

External and internal resets have no functional differences. In both cases, program execution starts at the address at 0000H and 0001H when the reset signal is generated.

A reset is applied when a low level is input to the $\overline{\text{RESET}}$ pin, the watchdog timer overflows, or by POC and LVI circuit voltage detection, and each item of hardware is set to the status shown in Tables 22-1 and 22-2. Each pin is high impedance during reset signal generation or during the oscillation stabilization time just after a reset release, except for P130, which is low-level output.

When a low level is input to the $\overline{\text{RESET}}$ pin, the device is reset. It is released from the reset status when a high level is input to the $\overline{\text{RESET}}$ pin and program execution is started with the internal high-speed oscillation clock after reset processing. A reset by the watchdog timer is automatically released, and program execution starts using the internal high-speed oscillation clock (see **Figures 22-2 to 22-4**) after reset processing. Reset by POC and LVI circuit power supply detection is automatically released when $V_{DD} \geq V_{POC}$ or $V_{DD} \geq V_{LVI}$ after the reset, and program execution starts using the internal high-speed oscillation clock (see **CHAPTER 23 POWER-ON-CLEAR CIRCUIT** and **CHAPTER 24 LOW-VOLTAGE DETECTOR**) after reset processing.

- Cautions**
1. For an external reset, input a low level for 10 μs or more to the $\overline{\text{RESET}}$ pin.
 2. During reset input, the X1 clock, XT1 clock, internal high-speed oscillation clock, and internal low-speed oscillation clock stop oscillating. External main system clock input and external subsystem clock input become invalid.
 3. When the STOP mode is released by a reset, the STOP mode contents are held during reset input. However, the port pins become high-impedance, except for P130, which is set to low-level output.

★

Figure 22-2. Timing of Reset by RESET Input

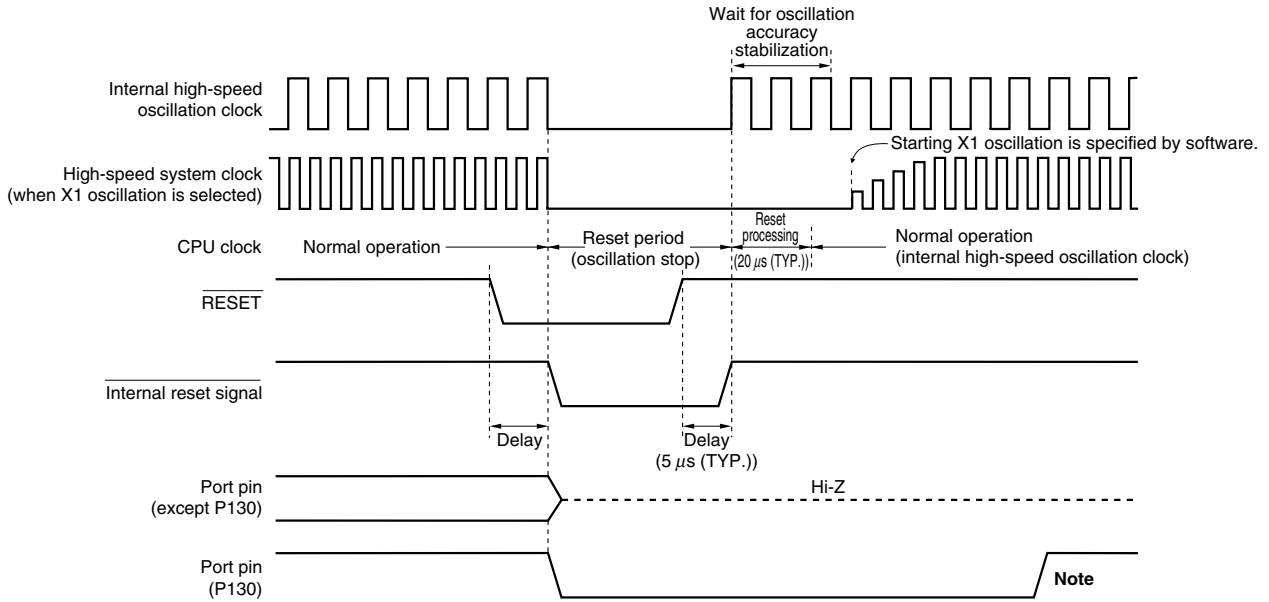

Note Set P130 to high-level output by software.

Remark When reset is effected, P130 outputs a low level. If P130 is set to output a high level before reset is effected, the output signal of P130 can be dummy-output as the CPU reset signal.

★

Figure 22-3. Timing of Reset Due to Watchdog Timer Overflow

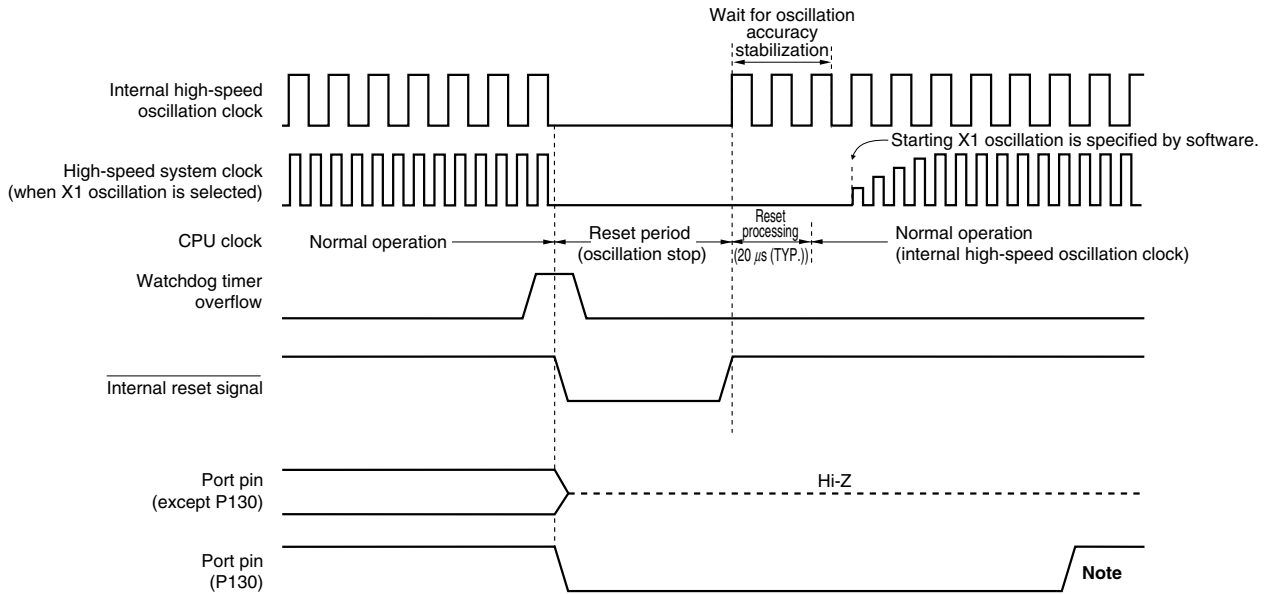

Note Set P130 to high-level output by software.

Caution A watchdog timer internal reset resets the watchdog timer.

Remark When reset is effected, P130 outputs a low level. If P130 is set to output a high level before reset is effected, the output signal of P130 can be dummy-output as the CPU reset signal.

★

Figure 22-4. Timing of Reset in STOP Mode by RESET Input

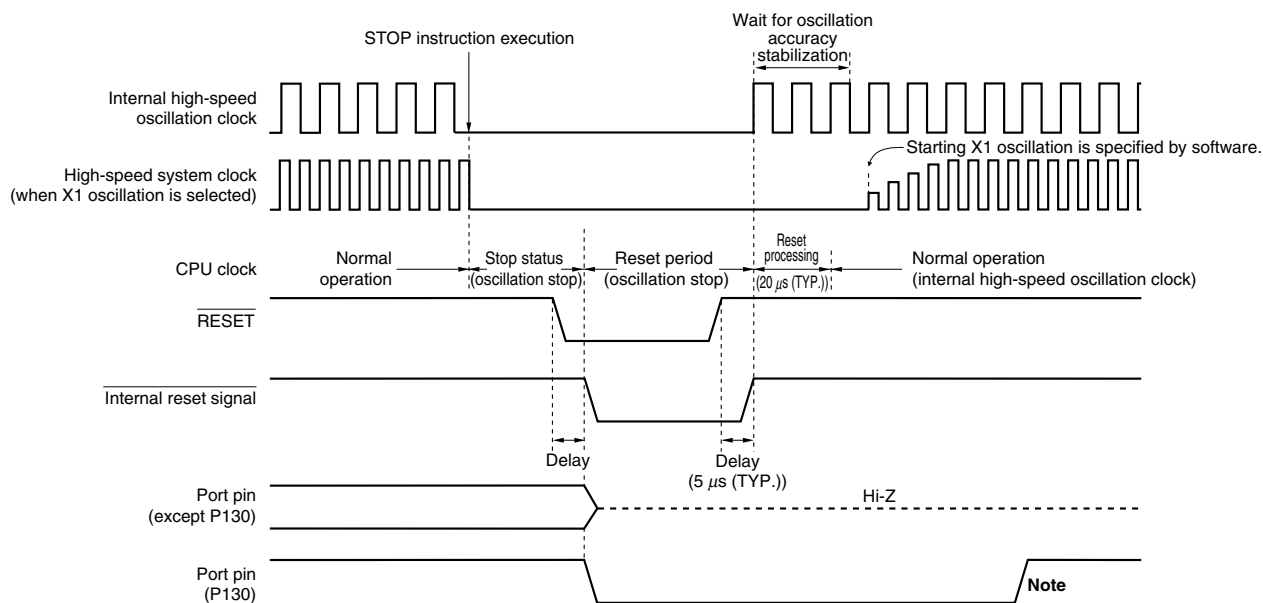

Note Set P130 to high-level output by software.

- Remarks**
1. When reset is effected, P130 outputs a low level. If P130 is set to output a high level before reset is effected, the output signal of P130 can be dummy-output as the CPU reset signal.
 2. For the reset timing of the power-on-clear circuit and low-voltage detector, see **CHAPTER 23 POWER-ON-CLEAR CIRCUIT** and **CHAPTER 24 LOW-VOLTAGE DETECTOR**.

Table 22-1. Operation Statuses During Reset Period

Item	During Reset Period	
System clock	Clock supply to the CPU is stopped.	
Main system clock	f _{RH}	Operation stopped
	f _x	Operation stopped (pin is I/O port mode)
	f _{EXCLK}	Clock input invalid (pin is I/O port mode)
Subsystem clock	f _{XT}	Operation stopped (pin is I/O port mode)
	f _{EXCLKS}	Clock input invalid (pin is I/O port mode)
f _{RL}	Operation stopped	
CPU	Operation stopped	
Flash memory		
RAM		
Port (latch)		
16-bit timer/event counter	00	Operation stopped
	01 ^{Note}	
8-bit timer/event counter	50	Operation stopped
	51	
8-bit timer	H0	Operation stopped
	H1	
Watch timer	Operation stopped	
Watchdog timer	Operation stopped	
Clock output	Operation stopped	
Buzzer output	Operation stopped	
A/D converter	Operation stopped	
Serial interface	UART0	Operation stopped
	UART6	
	CSI10	
	CSI11 ^{Note}	
	IIC0	
Multiplier/divider ^{Note}	Operation stopped	
Power-on-clear function	Operable	
Low-voltage detection function	Operation stopped	
External interrupt	Operation stopped	

★
★

Note μ PD78F0534, 78F0535, 78F0536, 78F0537, and 78F0537D only.

Remark f_{RH}: Internal high-speed oscillation clock
 f_x: X1 oscillation clock
 f_{EXCLK}: External main system clock
 f_{XT}: XT1 oscillation clock
 f_{EXCLKS}: External subsystem clock
 f_{RL}: Internal low-speed oscillation clock

Table 22-2. Hardware Statuses After Reset Acknowledgment (1/3)

Hardware		After Reset Acknowledgment ^{Note 1}
Program counter (PC)		The contents of the reset vector table (0000H, 0001H) are set.
Stack pointer (SP)		Undefined
Program status word (PSW)		02H
RAM	Data memory	Undefined ^{Note 2}
	General-purpose registers	Undefined ^{Note 2}
Port registers (P0 to P7, P12 to P14) (output latches)		00H
Port mode registers (PM0 to PM7, PM12, PM14)		FFH
Pull-up resistor option registers (PU0, PU1, PU3 to PU5, PU7, PU12, PU14)		00H
Internal expansion RAM size switching register (IXS)		0CH ^{Note 3}
Internal memory size switching register (IMS)		CFH ^{Note 3}
Memory bank select register (BANK)		00H
Clock operation mode select register (OSCCTL)		00H
Processor clock control register (PCC)		01H
Internal oscillation mode register (RCM)		80H
Main OSC control register (MOC)		80H
Main clock mode register (MCM)		00H
Oscillation stabilization time counter status register (OSTC)		00H
Oscillation stabilization time select register (OSTS)		05H
16-bit timer/event counters 00, 0 ^{Note 4}	Timer counters 00, 01 (TM00, TM01)	0000H
	Capture/compare registers 000, 010, 001, 011 (CR000, CR010, CR001, CR011)	0000H
	Mode control registers 00, 01 (TMC00, TMC01)	00H
	Prescaler mode registers 00, 01 (PRM00, PRM01)	00H
	Capture/compare control registers 00, 01 (CRC00, CRC01)	00H
	Timer output control registers 00, 01 (TOC00, TOC01)	00H

Notes 1. During reset signal generation or oscillation stabilization time wait, only the PC contents among the hardware statuses become undefined. All other hardware statuses remain unchanged.

Table 22-2. Hardware Statuses After Reset Acknowledgment (2/3)

Hardware		Status After Reset Acknowledgment ^{Note 1}
8-bit timer/event counters 50, 51	Timer counters 50, 51 (TM50, TM51)	00H
	Compare registers 50, 51 (CR50, CR51)	00H
	Timer clock selection registers 50, 51 (TCL50, TCL51)	00H
	Mode control registers 50, 51 (TMC50, TMC51)	00H
8-bit timers H0, H1	Compare registers 00, 10, 01, 11 (CMP00, CMP10, CMP01, CMP11)	00H
	Mode registers (TMHMD0, TMHMD1)	00H
	Carrier control register 1 (TMCYC1) ^{Note 2}	00H
Watch timer	Operation mode register (WTM)	00H
Clock output/buzzer output controller	Clock output selection register (CKS)	00H
Watchdog timer	Enable register (WDTE)	1AH/9AH ^{Note 3}
A/D converter	10-bit A/D conversion result register (ADCR)	0000H
	8-bit A/D conversion result register (ADCRH)	00H
	Mode register (ADM)	00H
	Analog input channel specification register (ADS)	00H
	A/D port configuration register (ADPC)	00H
Serial interface UART0	Receive buffer register 0 (RXB0)	FFH
	Transmit shift register 0 (TXS0)	FFH
	Asynchronous serial interface operation mode register 0 (ASIM0)	01H
	Asynchronous serial interface reception error status register 0 (ASIS0)	00H
	Baud rate generator control register 0 (BRGC0)	1FH
Serial interface UART6	Receive buffer register 6 (RXB6)	FFH
	Transmit buffer register 6 (TXB6)	FFH
	Asynchronous serial interface operation mode register 6 (ASIM6)	01H
	Asynchronous serial interface reception error status register 6 (ASIS6)	00H
	Asynchronous serial interface transmission status register 6 (ASIF6)	00H
	Clock selection register 6 (CKSR6)	00H
	Baud rate generator control register 6 (BRGC6)	FFH
	Asynchronous serial interface control register 6 (ASICL6)	16H
Input switch control register (ISC)	00H	
Serial interfaces CSI10, CSI1 ^{Note 4}	Transmit buffer registers 10, 11 (SOTB10, SOTB11)	00H
	Serial I/O shift registers 10, 11 (SIO10, SIO11)	00H
	Serial operation mode registers 10, 11 (CSIM10, CSIM11)	00H
	Serial clock selection registers 10, 11 (CSIC10, CSIC11)	00H

Notes 1. During reset signal generation or oscillation stabilization time wait, only the PC contents among the hardware statuses become undefined. All other hardware statuses remain unchanged after reset.

2. 8-bit timer H1 only.

3. The reset value of WDTE is determined by the option byte setting.

4. Serial interface CSI11 is available only in the μ PD78F0534, 78F0535, 78F0536, 78F0537, and 78F0537D.

Table 22-2. Hardware Statuses After Reset Acknowledgment (3/3)

Hardware		Status After Reset Acknowledgment ^{Note 1}
Serial interface IIC0	Shift register 0 (IIC0)	00H
	Control register 0 (IICC0)	00H
	Slave address register 0 (SVA0)	00H
	Clock selection register 0 (IICCL0)	00H
	Function expansion register 0 (IICX0)	00H
	Status register 0 (IICS0)	00H
	Flag register 0 (IICF0)	00H
Multiplier/divider ^{Note 2}	Remainder data register 0 (SDR0)	0000H
	Multiplication/division data register A0 (MDA0H, MDA0L)	0000H
	Multiplication/division data register B0 (MDB0)	0000H
	Multiplier/divider control register 0 (DMUC0)	00H
Key interrupt	Key return mode register (KRM)	00H
Reset function	Reset control flag register (RESF)	00H ^{Note 3}
Low-voltage detector	Low-voltage detection register (LVIM)	00H ^{Note 3}
	Low-voltage detection level selection register (LVIS)	00H ^{Note 3}
Interrupt	Request flag registers 0L, 0H, 1L, 1H (IF0L, IF0H, IF1L, IF1H)	00H
	Mask flag registers 0L, 0H, 1L, 1H (MK0L, MK0H, MK1L, MK1H)	FFH
	Priority specification flag registers 0L, 0H, 1L, 1H (PR0L, PR0H, PR1L, PR1H)	FFH
	External interrupt rising edge enable register (EGP)	00H
	External interrupt falling edge enable register (EGN)	00H

- Notes**
1. During reset signal generation or oscillation stabilization time wait, only the PC contents among the hardware statuses become undefined. All other hardware statuses remain unchanged after reset.
 2. Multiplier/divider is available only in the μ PD78F0534, 78F0535, 78F0536, 78F0537, and 78F0537D.
 3. These values vary depending on the reset source.

Reset Source		RESET Input	Reset by POC	Reset by WDT	Reset by LVI
Register	RESF	Cleared (0)	Cleared (0)	Set (1)	Held
	WDTRF bit			Held	Set (1)
	LVIRF bit				
	LVIM	Cleared (00H)	Cleared (00H)	Cleared (00H)	Held
	LVIS				

★

22.1 Register for Confirming Reset Source

Many internal reset generation sources exist in the 78K0/KE2. The reset control flag register (RESF) is used to store which source has generated the reset request.

RESF can be read by an 8-bit memory manipulation instruction.

$\overline{\text{RESET}}$ input, reset by power-on-clear (POC) circuit, and reading RESF set RESF to 00H.

Figure 22-5. Format of Reset Control Flag Register (RESF)

Address: FFACH After reset: 00H^{Note} R

Symbol	7	6	5	4	3	2	1	0
RESF	0	0	0	WDTRF	0	0	0	LVIRF

WDTRF	Internal reset request by watchdog timer (WDT)
0	Internal reset request is not generated, or RESF is cleared.
1	Internal reset request is generated.

LVIRF	Internal reset request by low-voltage detector (LVI)
0	Internal reset request is not generated, or RESF is cleared.
1	Internal reset request is generated.

Note The value after reset varies depending on the reset source.

Caution Do not read data by a 1-bit memory manipulation instruction.

The status of RESF when a reset request is generated is shown in Table 22-3.

Table 22-3. RESF Status When Reset Request Is Generated

Reset Source	$\overline{\text{RESET}}$ Input	Reset by POC	Reset by WDT	Reset by LVI
Flag				
WDTRF	Cleared (0)	Cleared (0)	Set (1)	Held
LVIRF			Held	Set (1)

CHAPTER 23 POWER-ON-CLEAR CIRCUIT

23.1 Functions of Power-on-Clear Circuit

The power-on-clear circuit (POC) has the following functions.

- Generates internal reset signal at power on.
In the 1.59 V POC mode (option byte: POCMODE = 0), the reset signal is released when the supply voltage (V_{DD}) exceeds $1.59\text{ V} \pm 0.15\text{ V}$.
- ★ In the 2.7 V/1.59 V POC mode (option byte: POCMODE = 1), the reset signal is released when the supply voltage (V_{DD}) exceeds $2.7\text{ V} \pm 0.2\text{ V}$.
- Compares supply voltage (V_{DD}) and detection voltage ($V_{POC} = 1.59\text{ V} \pm 0.15\text{ V}$), generates internal reset signal when $V_{DD} < V_{POC}$, and releases reset when $V_{DD} \geq V_{POC}$.

Caution If an internal reset signal is generated in the POC circuit, the reset control flag register (RESF) is cleared to 00H.

Remark This product incorporates multiple hardware functions that generate an internal reset signal. A flag that indicates the reset source is located in the reset control flag register (RESF) for when an internal reset signal is generated by the watchdog timer (WDT) or low-voltage-detector (LVI). RESF is not cleared to 00H and the flag is set to 1 when an internal reset signal is generated by WDT or LVI. For details of RESF, see **CHAPTER 22 RESET FUNCTION**.

23.2 Configuration of Power-on-Clear Circuit

The block diagram of the power-on-clear circuit is shown in Figure 23-1.

Figure 23-1. Block Diagram of Power-on-Clear Circuit

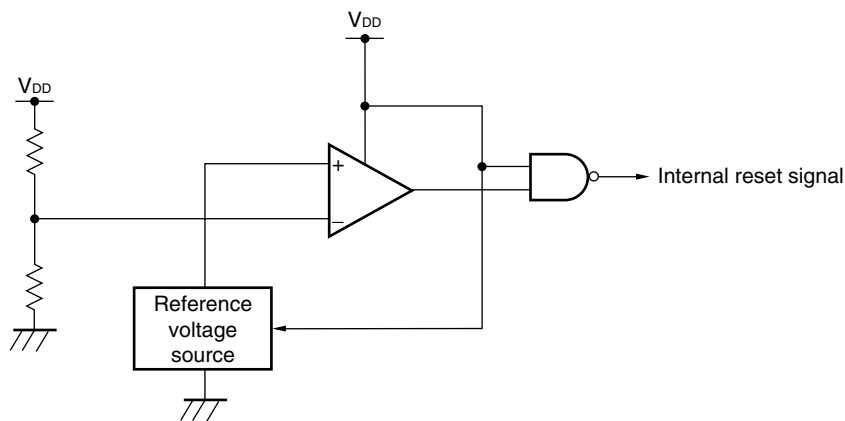

★ 23.3 Operation of Power-on-Clear Circuit

(1) In 1.59 V POC mode (option byte: POCMODE = 0)

- An internal reset signal is generated on power application. When the supply voltage (V_{DD}) exceeds the detection voltage ($V_{POC} = 1.59\text{ V} \pm 0.15\text{ V}$), the reset status is released.
- The supply voltage (V_{DD}) and detection voltage ($V_{POC} = 1.59\text{ V} \pm 0.15\text{ V}$) are compared. When $V_{DD} < V_{POC}$, the internal reset signal is generated. It is released when $V_{DD} \geq V_{POC}$.

(2) In 2.7 V/1.59 V POC mode (option byte: POCMODE = 1)

- An internal reset signal is generated on power application. When the supply voltage (V_{DD}) exceeds the detection voltage ($V_{DDPOC} = 2.7\text{ V} \pm 0.2\text{ V}$), the reset status is released.
- The supply voltage (V_{DD}) and detection voltage ($V_{POC} = 1.59\text{ V} \pm 0.15\text{ V}$) are compared. When $V_{DD} < V_{POC}$, the internal reset signal is generated. It is released when $V_{DD} \geq V_{POC}$.

The timing of generation of the internal reset signal by the power-on-clear circuit and low-voltage detector is shown below.

Figure 23-2. Timing of Generation of Internal Reset Signal by Power-on-Clear Circuit and Low-Voltage Detector (1/2)

(1) In 1.59 V POC mode (option byte: POCMODE = 0)

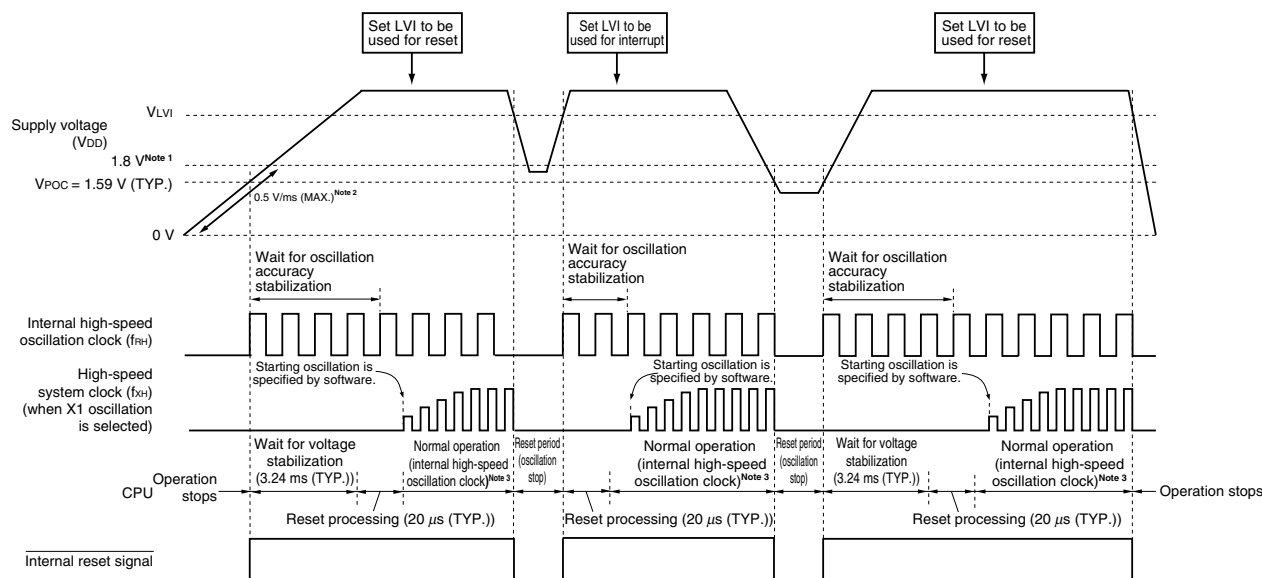

- Notes**
1. The operation guaranteed range is $1.8 \text{ V} \leq V_{DD} \leq 5.5 \text{ V}$. To make the state at lower than 1.8 V reset state when the supply voltage falls, use the reset function of the low-voltage detector, or input the low level to the $\overline{\text{RESET}}$ pin.
 2. If the voltage rises to 1.8 V at a rate slower than 0.5 V/ms (MAX.) on power application, input a low level to the $\overline{\text{RESET}}$ pin after power application and before the voltage reaches 1.8 V, or set the 2.7 V/1.59 V POC mode by using an option byte (POCMODE = 1).
 3. The internal high-speed oscillation clock and a high-speed system clock or subsystem clock can be selected as the CPU clock. To use the X1 clock, use the OSTC register to confirm the lapse of the oscillation stabilization time. To use the XT1 clock, use the timer function for confirmation of the lapse of the stabilization time.

Caution Set the low-voltage detector by software after the reset status is released (see CHAPTER 24 LOW-VOLTAGE DETECTOR).

Remark V_{LVI} : LVI detection voltage
 V_{POC} : POC detection voltage

Figure 23-2. Timing of Generation of Internal Reset Signal by Power-on-Clear Circuit and Low-Voltage Detector (2/2)

(2) In 2.7 V/1.59 V POC mode (option byte: POCMODE = 1)

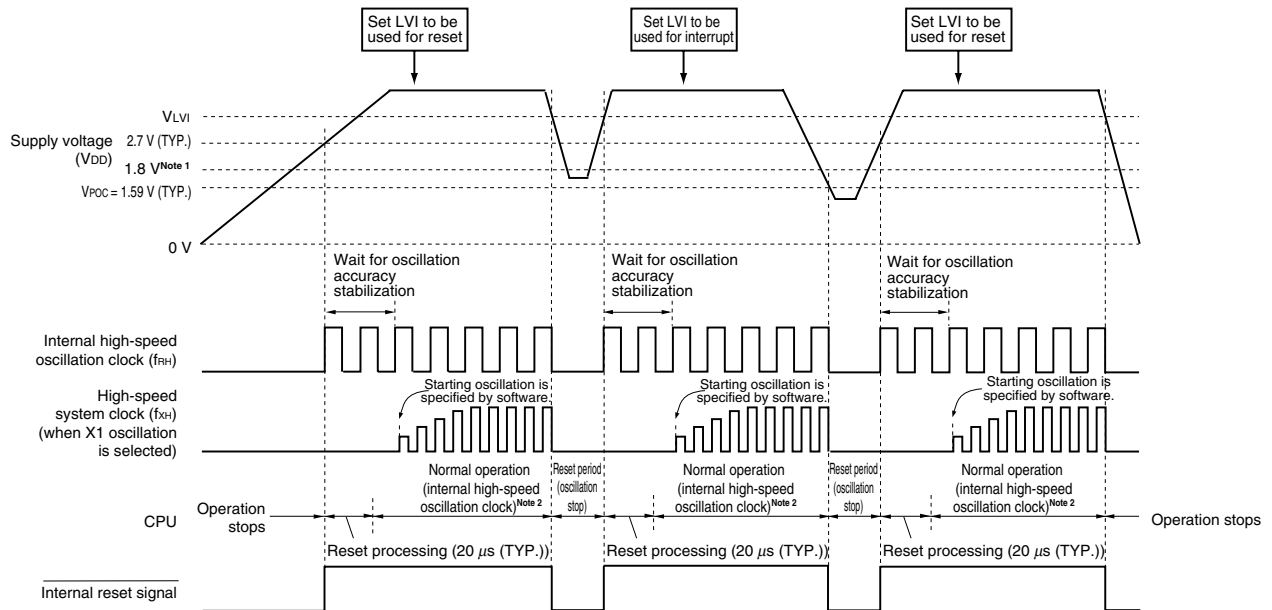

- Notes**
1. The operation guaranteed range is $1.8 \text{ V} \leq V_{DD} \leq 5.5 \text{ V}$. To make the state at lower than 1.8 V reset state when the supply voltage falls, use the reset function of the low-voltage detector, or input the low level to the $\overline{\text{RESET}}$ pin.
 2. The internal high-speed oscillation clock and a high-speed system clock or subsystem clock can be selected as the CPU clock. To use the X1 clock, use the OSTC register to confirm the lapse of the oscillation stabilization time. To use the XT1 clock, use the timer function for confirmation of the lapse of the stabilization time.

Caution Set the low-voltage detector by software after the reset status is released (see CHAPTER 24 LOW-VOLTAGE DETECTOR).

Remark V_{LVI}: LVI detection voltage
V_{POC}: POC detection voltage

23.4 Cautions for Power-on-Clear Circuit

In a system where the supply voltage (V_{DD}) fluctuates for a certain period in the vicinity of the POC detection voltage (V_{POC}), the system may be repeatedly reset and released from the reset status. In this case, the time from release of reset to the start of the operation of the microcontroller can be arbitrarily set by taking the following action.

<Action>

After releasing the reset signal, wait for the supply voltage fluctuation period of each system by means of a software counter that uses a timer, and then initialize the ports.

★ **Figure 23-3. Example of Software Processing After Reset Release (1/2)**

- If supply voltage fluctuation is 50 ms or less in vicinity of POC detection voltage

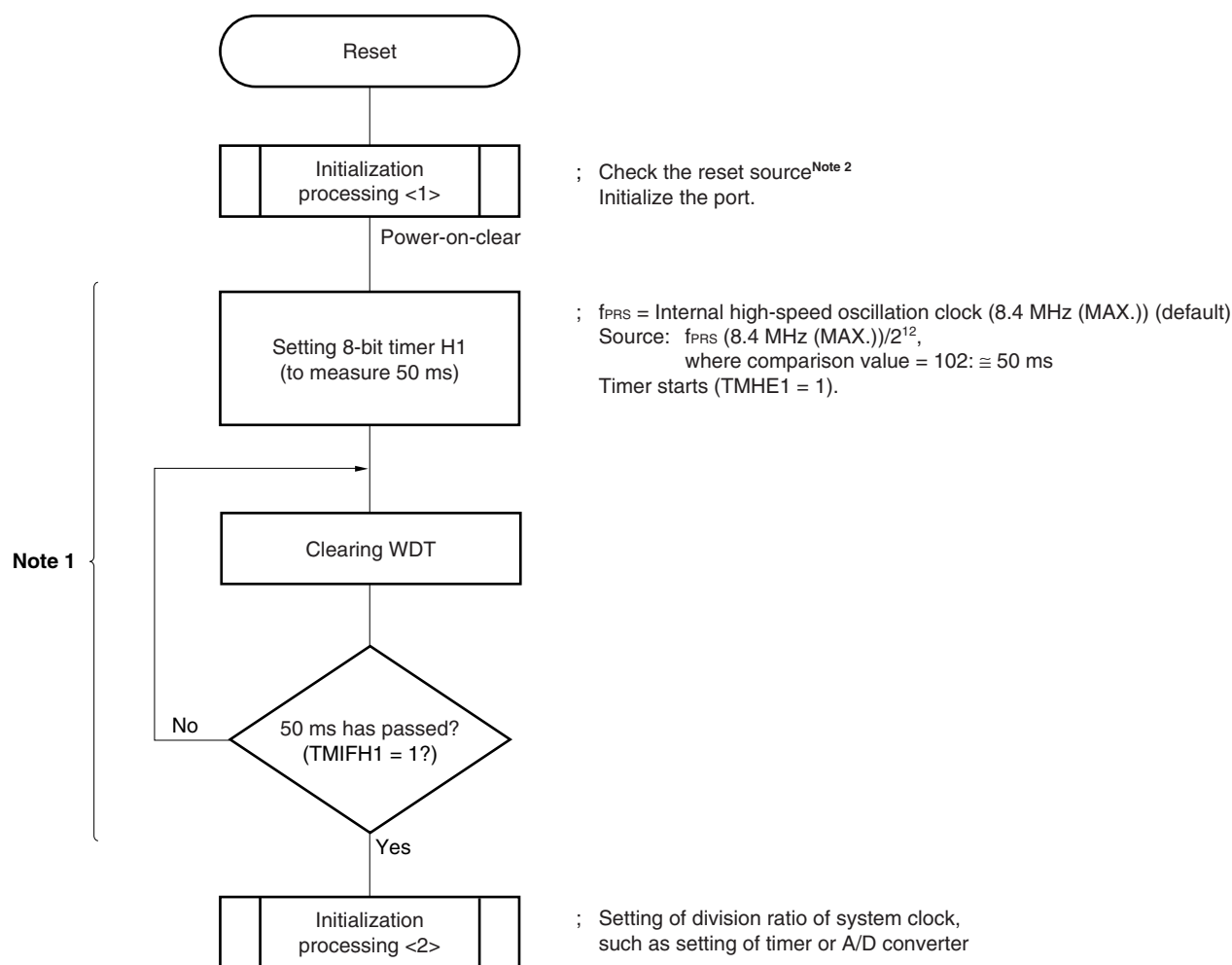

- Notes**
1. If reset is generated again during this period, initialization processing <2> is not started.
 2. A flowchart is shown on the next page.

Figure 23-3. Example of Software Processing After Reset Release (2/2)

- Checking reset source

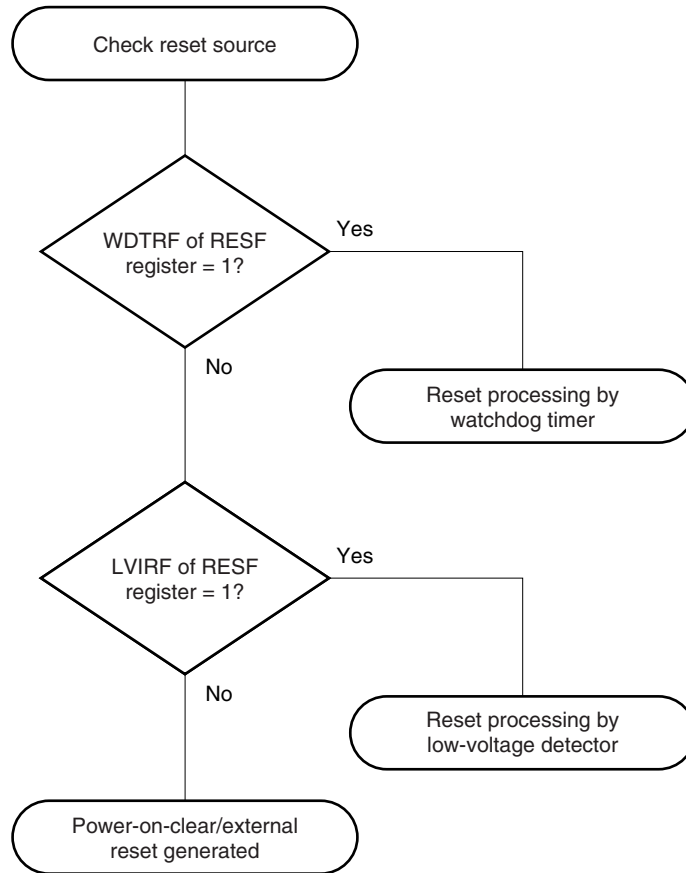

24.3 Registers Controlling Low-Voltage Detector

The low-voltage detector is controlled by the following registers.

- Low-voltage detection register (LVIM)
- Low-voltage detection level selection register (LVIS)
- Port mode register 12 (PM12)

(1) Low-voltage detection register (LVIM)

This register sets low-voltage detection and the operation mode.

This register can be set by a 1-bit or 8-bit memory manipulation instruction.

Reset signal generation sets LVIM to 00H.

Figure 24-2. Format of Low-Voltage Detection Register (LVIM)

Address: FFBEH After reset: 00H R/W^{Note 1}

Symbol	<7>	6	5	4	3	<2>	<1>	<0>
LVIM	LVION	0	0	0	0	LVISEL	LVIMD	LVIF

LVION ^{Notes 2, 3}	Enables low-voltage detection operation
0	Disables operation
1	Enables operation

LVISEL ^{Note 2}	Voltage detection selection
0	Detects level of supply voltage (V_{DD})
1	Detects level of input voltage from external input pin (EXLVI)

LVIMD ^{Note 2}	Low-voltage detection operation mode selection
0	<ul style="list-style-type: none"> • LVISEL = 0: Generates interrupt signal when supply voltage (V_{DD}) < detection voltage (V_{LVI}) • LVISEL = 1: Generates interrupt signal when input voltage from external input pin (EXLVI) < detection voltage (V_{EXLVI})
1	<ul style="list-style-type: none"> • LVISEL = 0: Generates internal reset signal when supply voltage (V_{DD}) < detection voltage (V_{LVI}) • LVISEL = 1: Generates internal reset signal when input voltage from external input pin (EXLVI) < detection voltage (V_{EXLVI})

LVIF ^{Note 4}	Low-voltage detection flag
0	<ul style="list-style-type: none"> • LVISEL = 0: Supply voltage (V_{DD}) \geq detection voltage (V_{LVI}), or when operation is disabled • LVISEL = 1: Input voltage from external input pin (EXLVI) \geq detection voltage (V_{EXLVI}), or when operation is disabled
1	<ul style="list-style-type: none"> • LVISEL = 0: Supply voltage (V_{DD}) < detection voltage (V_{LVI}) • LVISEL = 1: Input voltage from external input pin (EXLVI) < detection voltage (V_{EXLVI})

- Notes**
1. Bit 0 is read-only.
 2. LVION, LVIMD, and LVISEL are cleared to 0 in the case of a reset other than an LVI reset. These are not cleared to 0 in the case of an LVI reset.
 3. When LVION is set to 1, operation of the comparator in the LVI circuit is started. Use software to wait for an operation stabilization time (10 μ s (MAX.)) when LVION is set to 1 until the voltage is confirmed at LVIF.
 4. The value of LVIF is output as the interrupt request signal INTLVI when LVION = 1 and LVIMD = 0.

- Cautions**
1. To stop LVI, follow either of the procedures below.
 - When using 8-bit memory manipulation instruction: Write 00H to LVIM.
 - When using 1-bit memory manipulation instruction: Clear LVION to 0.
 2. Input voltage from external input pin (EXLVI) must be $EXLVI < V_{DD}$.

(2) Low-voltage detection level selection register (LVIS)

This register selects the low-voltage detection level.

This register can be set by a 1-bit or 8-bit memory manipulation instruction.

Reset signal generation input sets LVIS to 00H.

★

Figure 24-3. Format of Low-Voltage Detection Level Selection Register (LVIS)

Address: FFBFH After reset: 00H R/W

Symbol	7	6	5	4	3	2	1	0
LVIS	0	0	0	0	LVIS3	LVIS2	LVIS1	LVIS0

LVIS3	LVIS2	LVIS1	LVIS0	Detection level
0	0	0	0	V _{LV10} (4.24 V ±0.1 V)
0	0	0	1	V _{LV11} (4.09 V ±0.1 V)
0	0	1	0	V _{LV12} (3.93 V ±0.1 V)
0	0	1	1	V _{LV13} (3.78 V ±0.1 V)
0	1	0	0	V _{LV14} (3.62 V ±0.1 V)
0	1	0	1	V _{LV15} (3.47 V ±0.1 V)
0	1	1	0	V _{LV16} (3.32 V ±0.1 V)
0	1	1	1	V _{LV17} (3.16 V ±0.1 V)
1	0	0	0	V _{LV18} (3.01 V ±0.1 V)
1	0	0	1	V _{LV19} (2.85 V ±0.1 V)
1	0	1	0	V _{LV110} (2.70 V ±0.1 V)
1	0	1	1	V _{LV111} (2.55 V ±0.1 V)
1	1	0	0	V _{LV112} (2.39 V ±0.1 V)
1	1	0	1	V _{LV113} (2.24 V ±0.1 V)
1	1	1	0	V _{LV114} (2.08 V ±0.1 V)
1	1	1	1	V _{LV115} (1.93 V ±0.1 V)

- Cautions**
1. Be sure to clear bits 4 to 7 to 0.
 2. Do not change the value of LVIS during LVI operation.
 3. When an input voltage from the external input pin (EXLVI) is detected, the detection voltage (V_{EXLVI} = 1.21 V (TYP.)) is fixed. Therefore, setting of LVIS is not necessary.

(3) Port mode register 12 (PM12)

When using the P120/EXLVI/INTP0 pin for external low-voltage detection potential input, set PM120 to 1. At this time, the output latch of P120 may be 0 or 1.

PM12 can be set by a 1-bit or 8-bit memory manipulation instruction.

Reset signal generation sets PM12 to FFH.

Figure 24-4. Format of Port Mode Register 12 (PM12)

Address: FF2CH	After reset: FFH	R/W						
Symbol	7	6	5	4	3	2	1	0
PM12	1	1	1	PM124	PM123	PM122	PM121	PM120

PM12n	P12n pin I/O mode selection (n = 0 to 4)
0	Output mode (output buffer on)
1	Input mode (output buffer off)

24.4 Operation of Low-Voltage Detector

The low-voltage detector can be used in the following two modes.

(1) Used as reset

- If LVISEL = 0, compares the supply voltage (V_{DD}) and detection voltage (V_{LVI}), generates an internal reset signal when $V_{DD} < V_{LVI}$, and releases internal reset when $V_{DD} \geq V_{LVI}$.
- If LVISEL = 1, compares the input voltage from external input pin (EXLVI) and detection voltage ($V_{EXLVI} = 1.21 V(TYP.)$), generates an internal reset signal when $EXLVI < V_{EXLVI}$, and releases internal reset when $EXLVI \geq V_{EXLVI}$.

(2) Used as interrupt

- If LVISEL = 0, compares the supply voltage (V_{DD}) and detection voltage (V_{LVI}), and generates an interrupt signal (INTLVI) when $V_{DD} < V_{LVI}$.
- If LVISEL = 1, compares the input voltage from external input pin (EXLVI) and detection voltage ($V_{EXLVI} = 1.21 V(TYP.)$), and generates an interrupt signal (INTLVI) when $EXLVI < V_{EXLVI}$.

Remark LVISEL: Bit 2 of low-voltage detection register (LVIM)

24.4.1 When used as reset

(1) When detecting level of supply voltage (V_{DD})

- When starting operation
 - <1> Mask the LVI interrupt ($LVIMK = 1$).
 - <2> Clear bit 2 ($LVISEL$) of the low-voltage detection register ($LVIM$) to 0 (detects level of supply voltage (V_{DD})) (default value).
 - <3> Set the detection voltage using bits 3 to 0 ($LVIS3$ to $LVIS0$) of the low-voltage detection level selection register ($LVIS$).
 - <4> Set bit 7 ($LVION$) of $LVIM$ to 1 (enables LVI operation).
 - <5> Use software to wait for an operation stabilization time (10 μs (MAX.)).
 - <6> Wait until it is checked that (supply voltage (V_{DD}) \geq detection voltage (V_{LVI})) by bit 0 ($LVIF$) of $LVIM$.
 - <7> Set bit 1 ($LVIMD$) of $LVIM$ to 1 (generates internal reset signal when supply voltage (V_{DD}) < detection voltage (V_{LVI})).

Figure 24-5 shows the timing of the internal reset signal generated by the low-voltage detector. The numbers in this timing chart correspond to <1> to <7> above.

Cautions 1. <1> must always be executed. When $LVIMK = 0$, an interrupt may occur immediately after the processing in <4>.

2. If supply voltage (V_{DD}) \geq detection voltage (V_{LVI}) when $LVIMD$ is set to 1, an internal reset signal is not generated.

- When stopping operation

Either of the following procedures must be executed.

 - When using 8-bit memory manipulation instruction:

Write 00H to $LVIM$.
 - When using 1-bit memory manipulation instruction:

Clear $LVIMD$ to 0 and then $LVION$ to 0.

Figure 24-5. Timing of Low-Voltage Detector Internal Reset Signal Generation (Detects Level of Supply Voltage (V_{DD})) (1/2)

(1) In 1.59 V POC mode (option byte: POCMODE = 0)

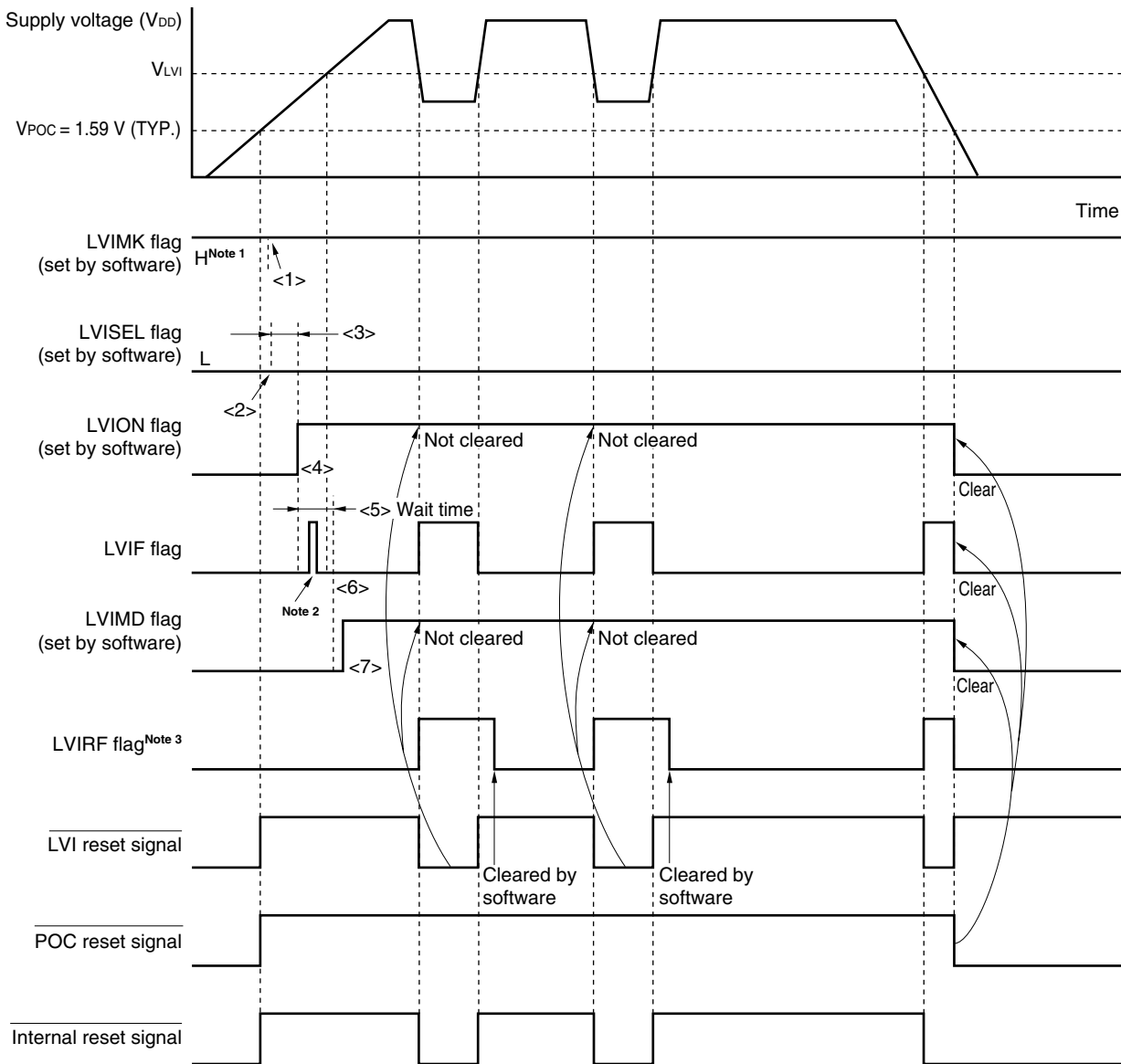

- Notes**
1. The LVIMK flag is set to "1" by reset signal generation.
 2. The LVIF flag may be set (1).
 3. LVIRF is bit 0 of the reset control flag register (RESF). For details of RESF, see **CHAPTER 22 RESET FUNCTION**.

Remark <1> to <7> in Figure 24-5 above correspond to <1> to <7> in the description of "When starting operation" in 24.4.1 (1) **When detecting level of supply voltage (V_{DD})**.

Figure 24-5. Timing of Low-Voltage Detector Internal Reset Signal Generation (Detects Level of Supply Voltage (V_{DD})) (2/2)

★ (2) In 2.7 V/1.59 V POC mode (option byte: POCMODE = 1)

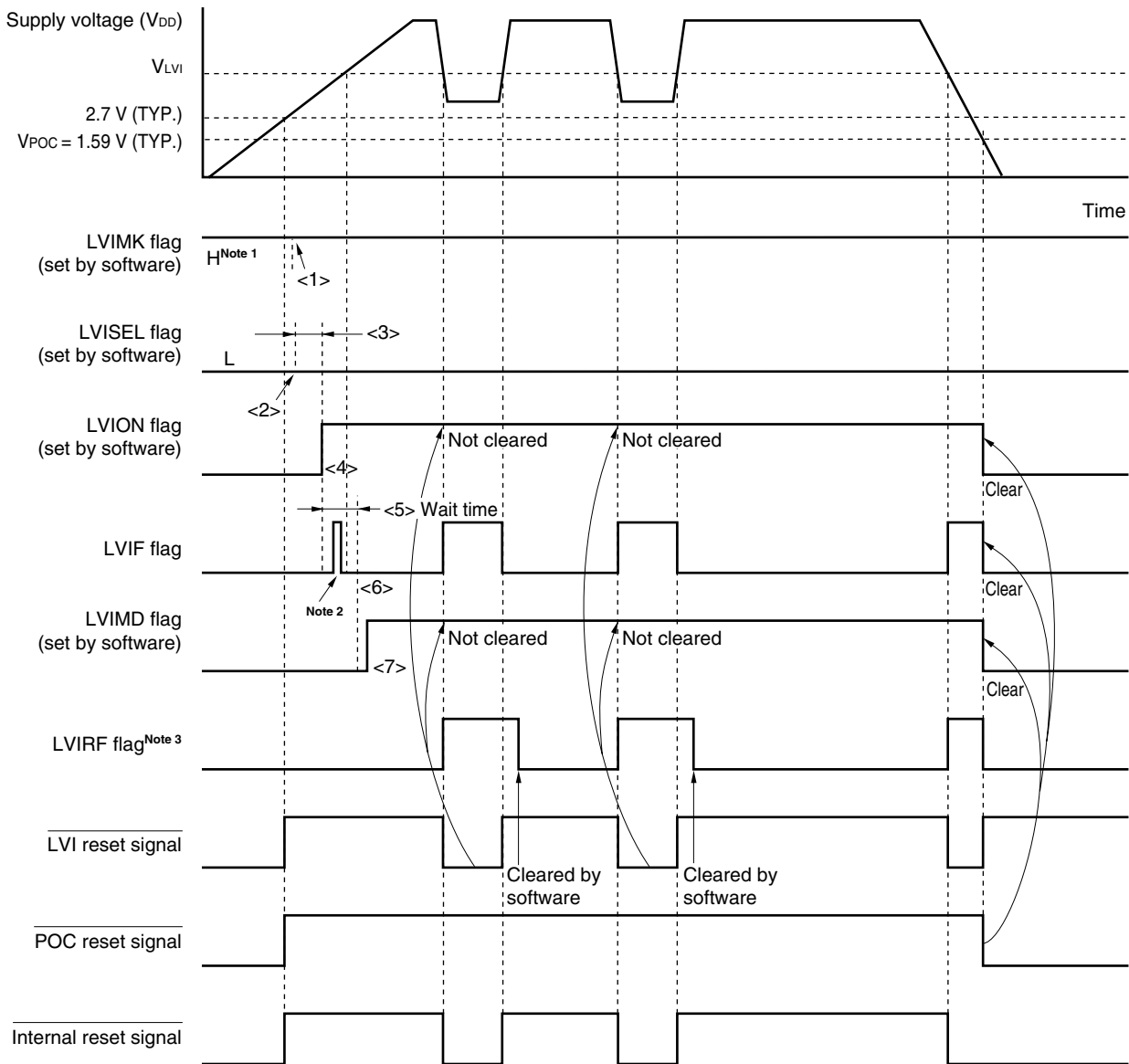

- Notes**
1. The LVIMK flag is set to "1" by reset signal generation.
 2. The LVIF flag may be set (1).
 3. LVIRF is bit 0 of the reset control flag register (RESF). For details of RESF, see **CHAPTER 22 RESET FUNCTION**.

Remark <1> to <7> in Figure 24-5 above correspond to <1> to <7> in the description of "When starting operation" in 24.4.1 (1) **When detecting level of supply voltage (V_{DD})**.

(2) When detecting level of input voltage from external input pin (EXLVI)

- When starting operation
 - <1> Mask the LVI interrupt (LVIMK = 1).
 - <2> Set bit 2 (LVISEL) of the low-voltage detection register (LVIM) to 1 (detects level of input voltage from external input pin (EXLVI)).
 - <3> Set bit 7 (LVION) of LVIM to 1 (enables LVI operation).
 - <4> Use software to wait for an operation stabilization time (10 μ s (MAX.)^{Note}).
 - <5> Wait until it is checked that (input voltage from external input pin (EXLVI) \geq detection voltage ($V_{EXLVI} = 1.21$ V (TYP.))) by bit 0 (LVIF) of LVIM.
 - <6> Set bit 1 (LVIMD) of LVIM to 1 (generates internal reset signal when input voltage from external input pin (EXLVI) < detection voltage ($V_{EXLVI} = 1.21$ V (TYP.))).

Figure 24-6 shows the timing of the internal reset signal generated by the low-voltage detector. The numbers in this timing chart correspond to <1> to <6> above.

Cautions 1. <1> must always be executed. When LVIMK = 0, an interrupt may occur immediately after the processing in <3>.

Figure 24-6. Timing of Low-Voltage Detector Internal Reset Signal Generation (Detects Level of Input Voltage from External Input Pin (EXLVI))

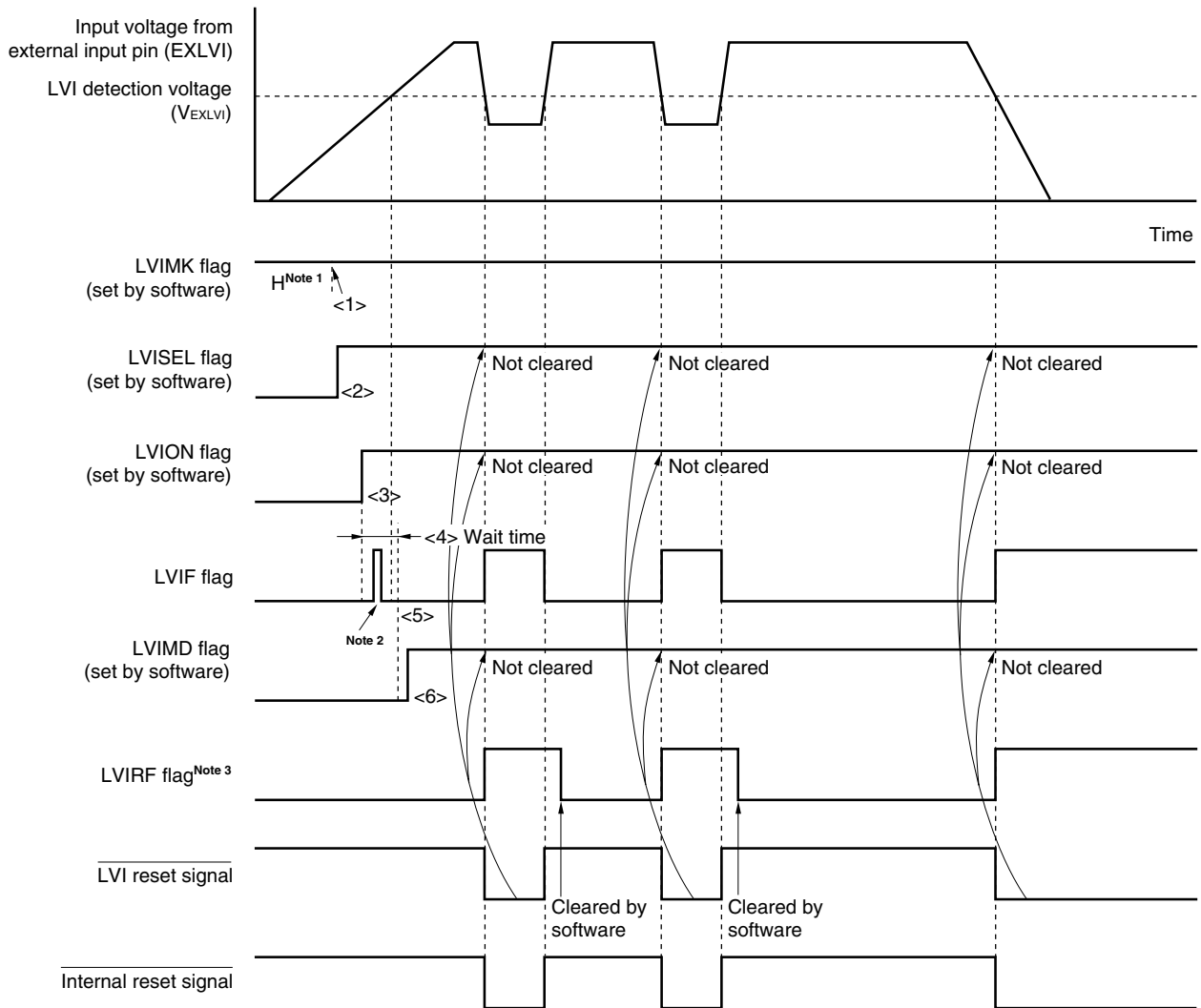

- Notes**
1. The LVIMK flag is set to “1” by reset signal generation.
 2. The LVIF flag may be set (1).
 3. LVIRF is bit 0 of the reset control flag register (RESF). For details of RESF, see **CHAPTER 22 RESET FUNCTION**.

Remark <1> to <6> in Figure 24-6 above correspond to <1> to <6> in the description of “When starting operation” in 24.4.1 (2) When detecting level of input voltage from external input pin (EXLVI).

24.4.2 When used as interrupt

(1) When detecting level of supply voltage (V_{DD})

- When starting operation
 - <1> Mask the LVI interrupt ($LVIMK = 1$).
 - <2> Clear bit 2 (LVISEL) of the low-voltage detection register (LVIM) to 0 (detects level of supply voltage (V_{DD})) (default value).
 - <3> Set the detection voltage using bits 3 to 0 (LVIS3 to LVIS0) of the low-voltage detection level selection register (LVIS).
 - <4> Set bit 7 (LVION) of LVIM to 1 (enables LVI operation).
 - <5> Use software to wait for an operation stabilization time (10 μ s (MAX.)).
 - <6> Confirm that “supply voltage (V_{DD}) \geq detection voltage (V_{LVI})” at bit 0 (LVIF) of LVIM.
 - <7> Clear the interrupt request flag of LVI (LVIIIF) to 0.
 - <8> Release the interrupt mask flag of LVI (LVIMK).
 - <9> Clear bit 1 (LVIMD) of LVIM to 0 (generates interrupt signal when supply voltage (V_{DD}) < detection voltage (V_{LVI})) (default value).
 - <10> Execute the EI instruction (when vector interrupts are used).

Figure 24-7 shows the timing of the interrupt signal generated by the low-voltage detector. The numbers in this timing chart correspond to <1> to <9> above.

- When stopping operation
 - Either of the following procedures must be executed.
 - When using 8-bit memory manipulation instruction:
Write 00H to LVIM.
 - When using 1-bit memory manipulation instruction:
Clear LVION to 0.

Figure 24-7. Timing of Low-Voltage Detector Interrupt Signal Generation (Detects Level of Supply Voltage (V_{DD})) (1/2)

★ (1) In 1.59 V POC mode (option byte: POCMODE = 0)

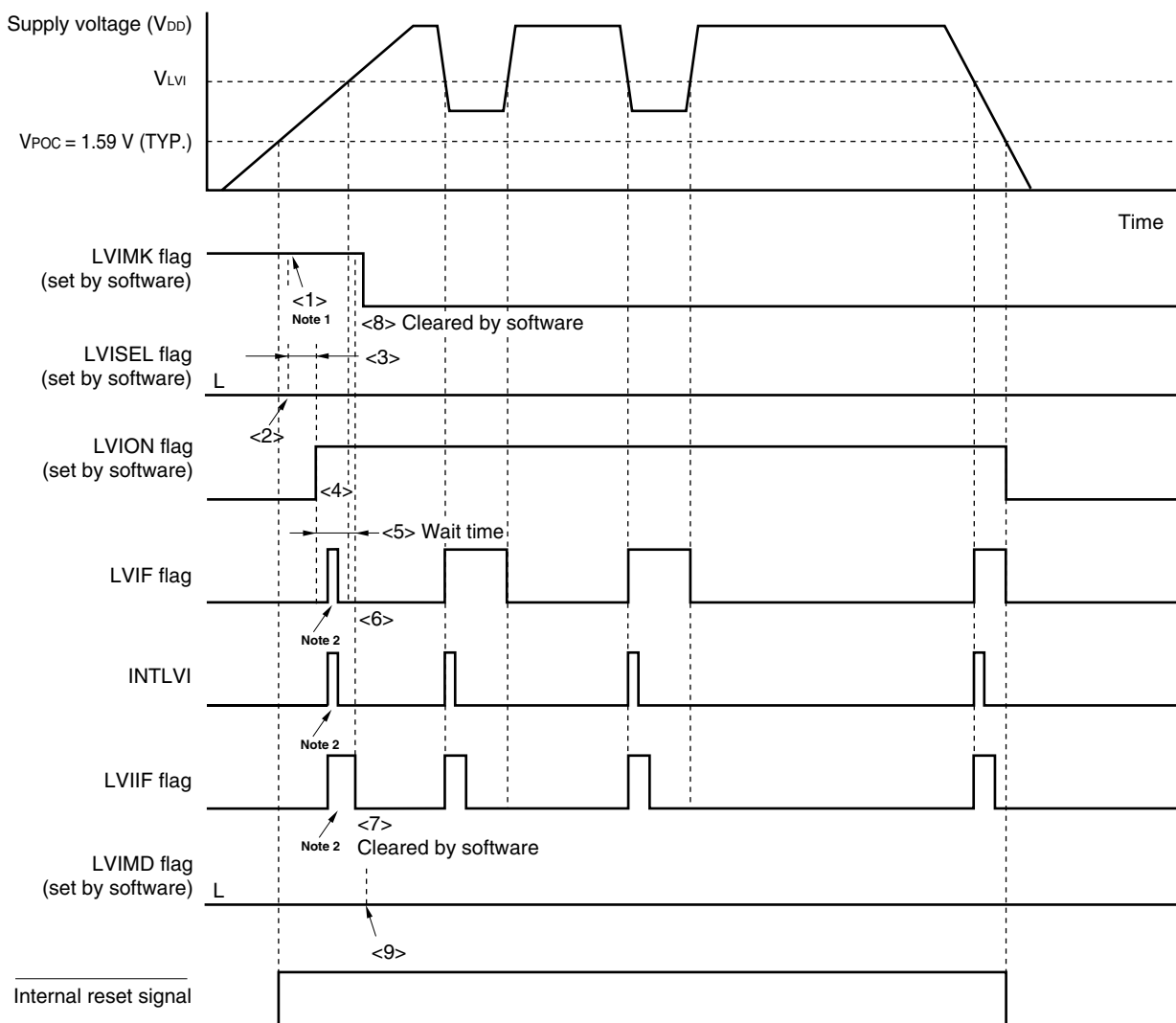

- Notes**
1. The LVIMK flag is set to "1" by reset signal generation.
 2. The interrupt request signal (INTLVI) is generated and the LVIF and LVIIF flags may be set (1).

Remark <1> to <9> in Figure 24-7 above correspond to <1> to <9> in the description of "When starting operation" in 24.4.2 (1) When detecting level of supply voltage (V_{DD}).

Figure 24-7. Timing of Low-Voltage Detector Interrupt Signal Generation
(Detects Level of Supply Voltage (V_{DD})) (2/2)

★ (2) In 2.7 V/1.59 V POC mode (option byte: POCMODE = 1)

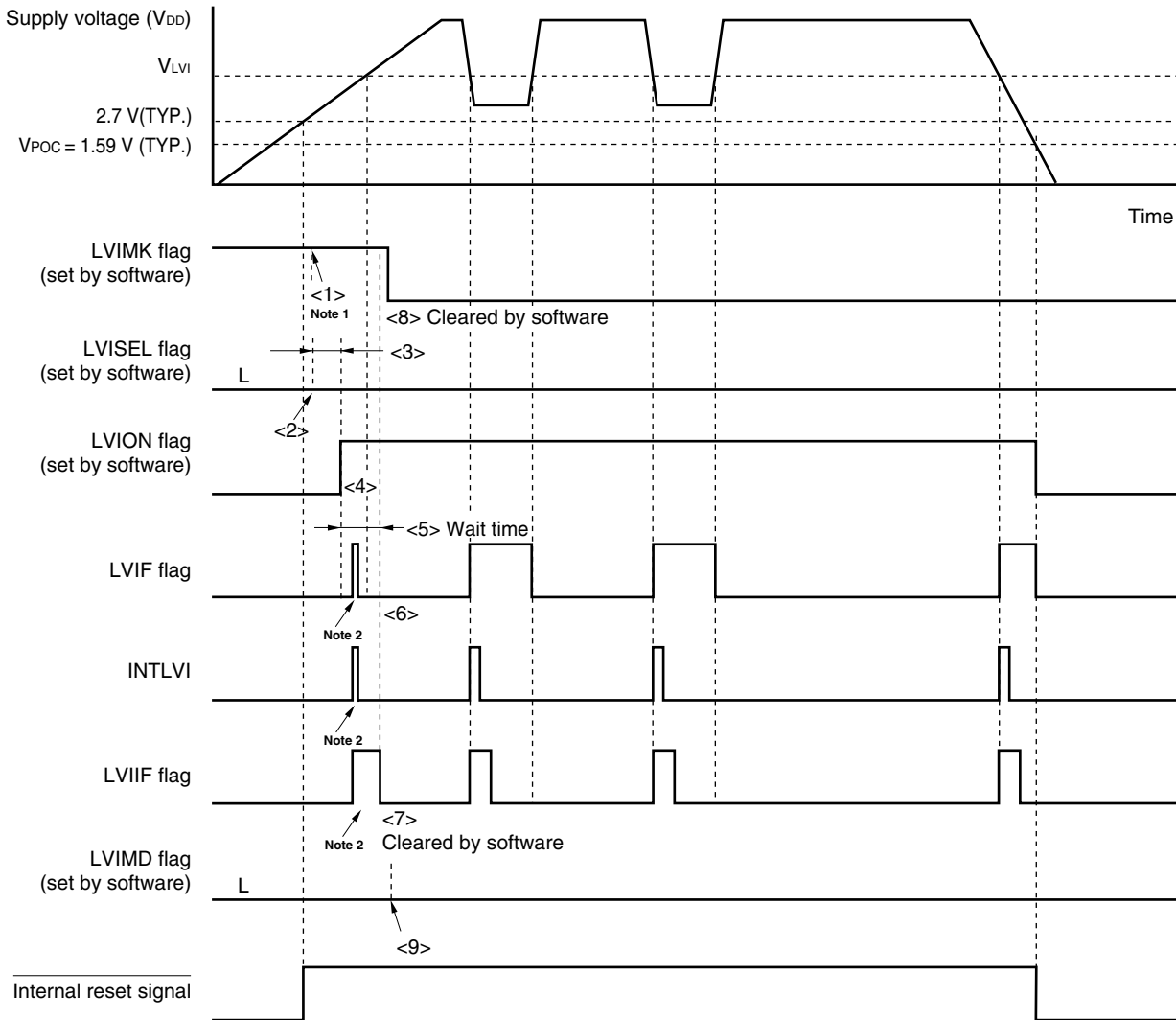

- Notes**
1. The LVIMK flag is set to "1" by reset signal generation.
 2. The interrupt request signal (INTLVI) is generated and the LVIF and LVIIF flags may be set (1).

Remark <1> to <9> in Figure 24-7 above correspond to <1> to <9> in the description of "When starting operation" in 24.4.2 (1) When detecting level of supply voltage (V_{DD}).

(2) When detecting level of input voltage from external input pin (EXLVI)

- When starting operation
 - <1> Mask the LVI interrupt (LVIMK = 1).
 - <2> Set bit 2 (LVISEL) of the low-voltage detection register (LVIM) to 1 (detects level of input voltage from external input pin (EXLVI)).
 - <3> Set bit 7 (LVION) of LVIM to 1 (enables LVI operation).
 - <4> Use software to wait for an operation stabilization time (10 μ s (MAX.)).
 - <5> Confirm that “input voltage from external input pin (EXLVI) \geq detection voltage ($V_{EXLVI} = 1.21$ V (TYP.))” at bit 0 (LVIF) of LVIM.
 - <6> Clear the interrupt request flag of LVI (LVIIF) to 0.
 - <7> Release the interrupt mask flag of LVI (LVIMK).
 - <8> Clear bit 1 (LVIMD) of LVIM to 0 (generates interrupt signal when supply voltage (V_{DD}) < detection voltage (V_{LVI})) (default value).
 - <9> Execute the EI instruction (when vector interrupts are used).

Figure 24-8 shows the timing of the interrupt signal generated by the low-voltage detector. The numbers in this timing chart correspond to <1> to <8> above.

Caution Input voltage from external input pin (EXLVI) must be $EXLVI < V_{DD}$.

- When stopping operation
 - Either of the following procedures must be executed.
 - When using 8-bit memory manipulation instruction:
Write 00H to LVIM.
 - When using 1-bit memory manipulation instruction:
Clear LVION to 0.

★ **Figure 24-8. Timing of Low-Voltage Detector Interrupt Signal Generation (Detects Level of Input Voltage from External Input Pin (EXLVI))**

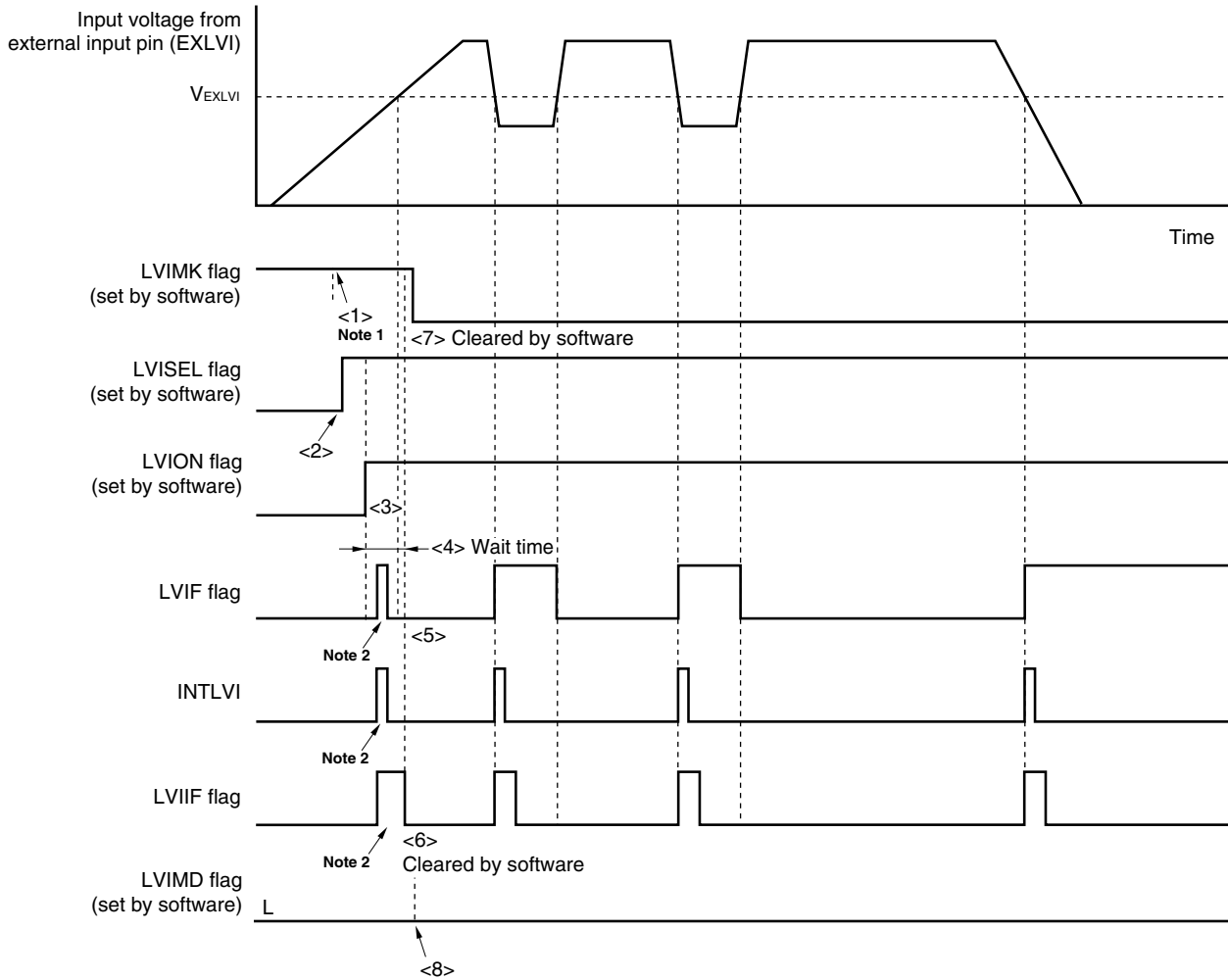

- Notes**
1. The LVIMK flag is set to “1” by reset signal generation.
 2. The interrupt request signal (INTLVI) is generated and the LVIF and LVIIF flags may be set (1).

Remark <1> to <8> in Figure 24-8 above correspond to <1> to <8> in the description of “When starting operation” in 24.4.2 (1) **When detecting level of supply voltage (V_{DD})**.

24.5 Cautions for Low-Voltage Detector

In a system where the supply voltage (V_{DD}) fluctuates for a certain period in the vicinity of the LVI detection voltage (V_{LVI}), the operation is as follows depending on how the low-voltage detector is used.

(1) When used as reset

The system may be repeatedly reset and released from the reset status.

In this case, the time from release of reset to the start of the operation of the microcontroller can be arbitrarily set by taking action (1) below.

(2) When used as interrupt

Interrupt requests may be frequently generated. Take (b) of action (2) below.

In this system, take the following actions.

<Action>

(1) When used as reset

After releasing the reset signal, wait for the supply voltage fluctuation period of each system by means of a software counter that uses a timer, and then initialize the ports (see **Figure 24-9**).

(2) When used as interrupt

- (a) Check that “supply voltage (V_{DD}) \geq detection voltage (V_{LVI})” in the servicing routine of the LVI interrupt by using bit 0 (LVIF) of the low-voltage detection register (LVIM). Clear bit 0 (LVIIF) of interrupt request flag register 0L (IF0L) to 0.
- (b) In a system where the supply voltage fluctuation period is long in the vicinity of the LVI detection voltage, wait for the supply voltage fluctuation period, check that “supply voltage (V_{DD}) \geq detection voltage (V_{LVI})” using the LVIF flag, and clear the LVIIF flag to 0.

Remark If bit 2 (LVISEL) of the low voltage detection register (LVIM) is set to “1”, the meanings of the above words change as follows.

- Supply voltage (V_{DD}) → Input voltage from external input pin (EXLVI)
- Detection voltage (V_{LVI}) → Detection voltage ($V_{EXLVI} = 1.21 V^{\text{Note}}$)

★ **Figure 24-9. Example of Software Processing After Reset Release (1/2)**

- If supply voltage fluctuation is 50 ms or less in vicinity of LVI detection voltage

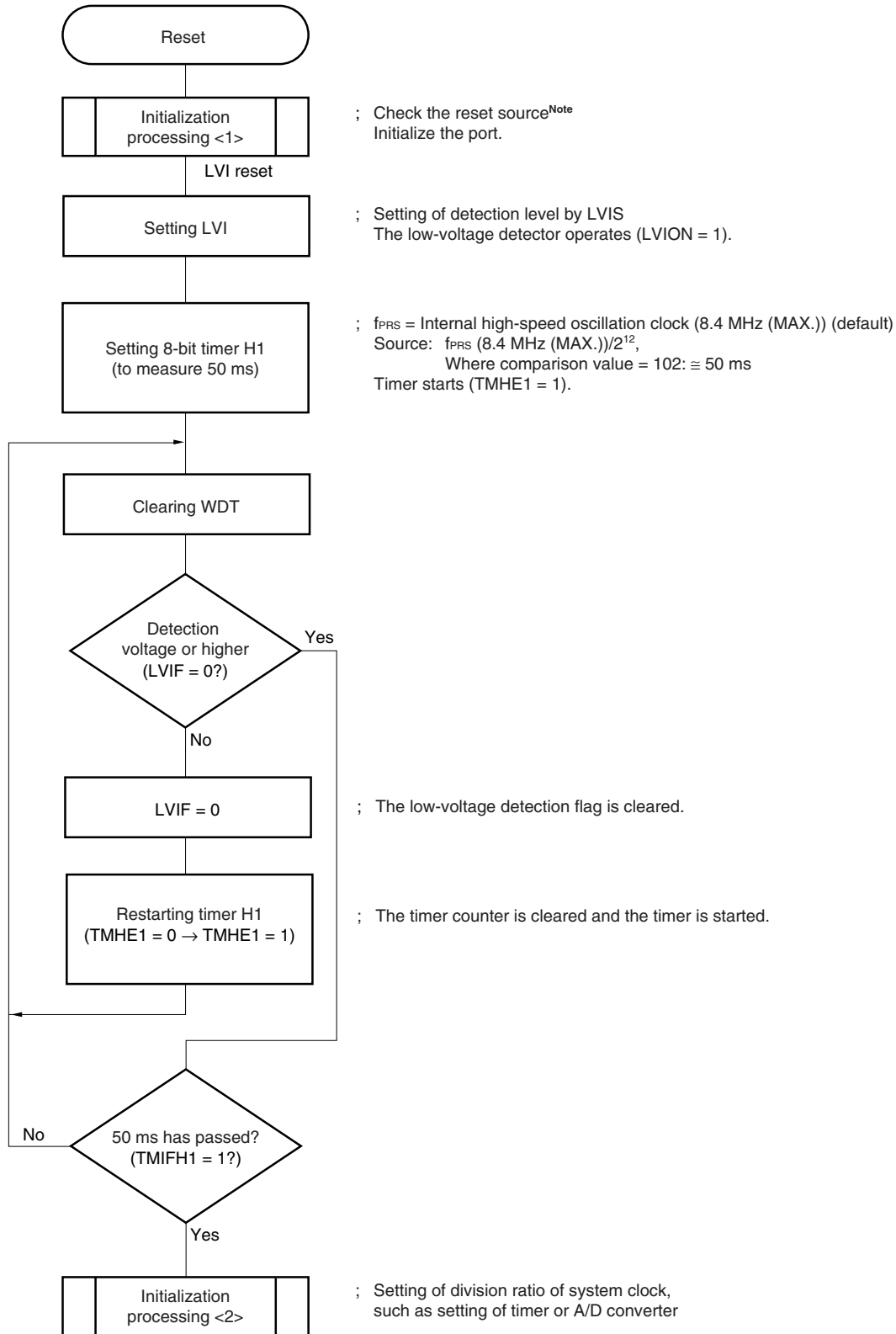

Note A flowchart is shown on the next page.

Figure 24-9. Example of Software Processing After Reset Release (2/2)

- Checking reset source

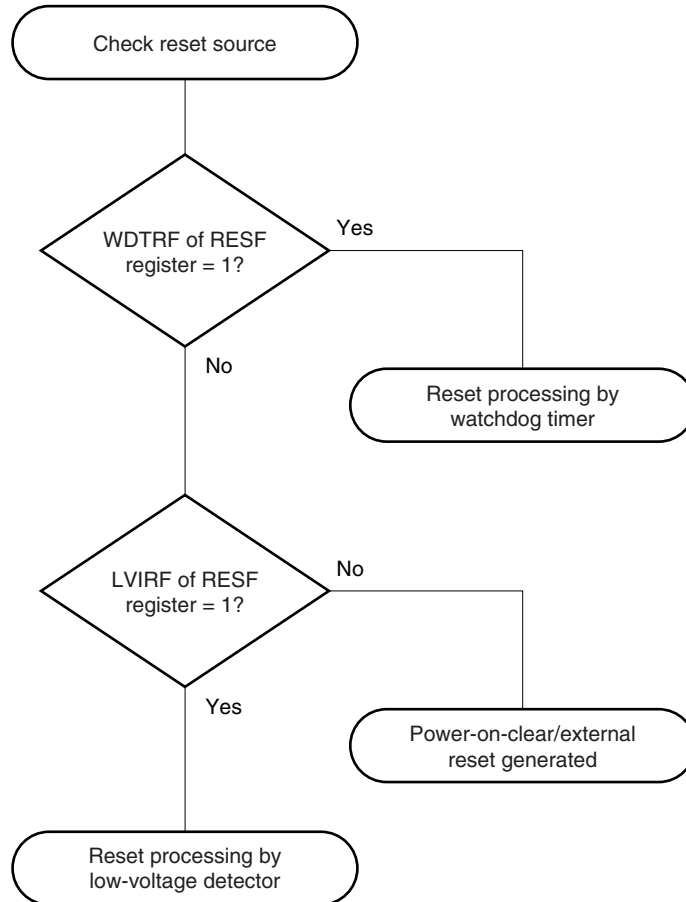

CHAPTER 25 OPTION BYTE

25.1 Functions of Option Bytes

- ★ The flash memory at 0080H to 0084H of the 78K0/KE2 is an option byte area. When power is turned on or when the device is restarted from the reset status, the device automatically references the option bytes and sets specified functions. When using the product, be sure to set the following functions by using the option bytes.

When the boot swap operation is used during self-programming, 0080H to 0084H are switched to 1080H to 1084H. Therefore, set values that are the same as those of 0080H to 0084H to 1080H to 1084H in advance.

(1) 0080H/1080H

- Internal low-speed oscillator operation
 - Can be stopped by software
 - Cannot be stopped
- Watchdog timer interval time setting
- Watchdog timer counter operation
 - Enabled counter operation
 - Disabled counter operation
- Watchdog timer window open period setting

★ (2) 0081H/1081H

- Selecting POC mode
 - During 2.7 V/1.59 V POC mode operation (POCMODE = 1)
The device is in the reset state upon power application and until the supply voltage reaches 2.7 V (TYP.). It is released from the reset state when the voltage exceeds 2.7 V (TYP.). After that, POC is not detected at 2.7 V but is detected at 1.59 V (TYP.).
If the supply voltage rises to 1.8 V after power application at a pace slower than 0.5 V/ms (MAX.), use of the 2.7 V/1.59 V POC mode is recommended.
 - During 1.59 V POC mode operation (POCMODE = 0)
The device is in the reset state upon power application and until the supply voltage reaches 1.59 V (TYP.). It is released from the reset state when the voltage exceeds 1.59 V (TYP.). After that, POC is detected at 1.59 V (TYP.), in the same manner as on power application.

★ (3) 0084H/1084H

- On-chip debug operation control
 - Disabling on-chip debug operation
 - Enabling on-chip debug operation and erasing data of the flash memory in case authentication of the on-chip debug security ID fails
 - Enabling on-chip debug operation and not erasing data of the flash memory even in case authentication of the on-chip debug security ID fails

Cautions 1. Be sure to set 00H (disabling on-chip debug operation) to 0084H for products not equipped with the on-chip debug function (μ PD78F0531, 78F0532, 78F0533, 78F0534, 78F0535, 78F0536, and 78F0537). Also set 00H to 1084H because 0084H and 1084H are switched at boot swapping.

2. To use the on-chip debug function with a product equipped with the on-chip debug function (μ PD78F0537D), set 02H or 03H to 0084H. Set a value that is the same as that of 0084H to 1084H because 0084H and 1084H are switched at boot swapping.

- ★ **Caution** Be sure to set 00H to 0082H and 0083H (0082H/1082H and 0083H/1083H when the boot swap function is used).

25.2 Format of Option Byte

The format of the option byte is shown below.

Figure 25-1. Format of Option Byte (1/2)

Address: 0080H/1080H^{Note}

7	6	5	4	3	2	1	0
0	WINDOW1	WINDOW0	WDTON	WDCS2	WDCS1	WDCS0	LSROSC
WINDOW1		WINDOW0	Watchdog timer window open period				
0		0	25%				
0		1	50%				
1		0	75%				
1		1	100%				
WDTON		Operation control of watchdog timer counter/illegal access detection					
0		Counter operation disabled (counting stopped after reset), illegal access detection operation disabled					
1		Counter operation enabled (counting started after reset), illegal access detection operation enabled					
WDCS2		WDCS1	WDCS0	Watchdog timer overflow time			
0		0	0	$2^{10}/f_{RL}$ (3.88 ms)			
0		0	1	$2^{11}/f_{RL}$ (7.76 ms)			
0		1	0	$2^{12}/f_{RL}$ (15.52 ms)			
0		1	1	$2^{13}/f_{RL}$ (31.03 ms)			
1		0	0	$2^{14}/f_{RL}$ (62.06 ms)			
1		0	1	$2^{15}/f_{RL}$ (124.12 ms)			
1		1	0	$2^{16}/f_{RL}$ (248.24 ms)			
1		1	1	$2^{17}/f_{RL}$ (496.48 ms)			
LSROSC		Internal low-speed oscillator operation					
0		Can be stopped by software (stopped when 1 is written to bit 0 (LSRSTOP) of RCM register)					
1		Cannot be stopped (not stopped even if 1 is written to LSRSTOP bit)					

★ **Note** Set a value that is the same as that of 0080H to 1080H because 0080H and 1080H are switched during the boot swap operation.

- Cautions**
1. The combination of $WDCS2 = WDCS1 = WDCS0 = 0$ and $WINDOW1 = WINDOW0 = 0$ is prohibited.
 2. The watchdog timer does not stop during self-programming of the flash memory and EEPROM emulation. During processing, the interrupt acknowledge time is delayed. Set the overflow time and window size taking this delay into consideration.
 3. If $LSROSC = 0$ (oscillation can be stopped by software), the count clock is not supplied to the watchdog timer in the HALT and STOP modes, regardless of the setting of bit 0 (LSRSTOP) of the internal oscillation mode register (RCM).
When 8-bit timer H1 operates with the internal low-speed oscillation clock, the count clock is supplied to 8-bit timer H1 even in the HALT/STOP mode.
 4. Be sure to clear bit 7 to 0.

- Remarks**
1. f_{RL} : Internal low-speed oscillation clock frequency
 2. (): $f_{RL} = 264$ kHz (MAX.)

Figure 25-1. Format of Option Byte (2/2)

★ Address: 0081H/1081H^{Notes 1, 2}

7	6	5	4	3	2	1	0
0	0	0	0	0	0	0	POCMODE

POCMODE	POC mode selection
0	1.59 V POC mode (default)
1	2.7 V/1.59 V POC mode

- Notes**
1. POCMODE can only be written by using a dedicated flash programmer. It cannot be set during self-programming or boot swap operation during self-programming (at this time, 1.59 V POC mode (default) is set). However, because the value of 1081H is copied to 0081H during the boot swap operation, it is recommended to set a value that is the same as that of 0081H to 1081H when the boot swap function is used.
 2. To change the setting for the POC mode, set the value to 0081H again after batch erasure (chip erasure) of the flash memory. The setting cannot be changed after the memory of the specified block is erased.

Caution Be sure to clear bits 7 to 1 to 0.

★ Address: 0082H/1082H, 0083H/1083H^{Note}

7	6	5	4	3	2	1	0
0	0	0	0	0	0	0	0

Note Be sure to set 00H to 0082H and 0083H, as these addresses are reserved areas. Also set 00H to 1082 and 1083H because 0082H and 0083H are switched with 1082H and 1083H when the boot swap operation is used.

★ Address: 0084H/1084H^{Notes 1, 2}

7	6	5	4	3	2	1	0
0	0	0	0	0	0	OCDEN1	OCDEN0

OCDEN1	OCDEN0	On-chip debug operation control
0	0	Operation disabled
0	1	Setting prohibited
1	0	Operation enabled. Does not erase data of the flash memory in case authentication of the on-chip debug security ID fails.
1	1	Operation enabled. Erases data of the flash memory in case authentication of the on-chip debug security ID fails.

- Notes**
1. Be sure to set 00H (on-chip debug operation disabled) to 0084H for products not equipped with the on-chip debug function (μ PD78F0531, 78F0532, 78F0533, 78F0534, 78F0535, 78F0536, and 78F0537). Also set 00H to 1084H because 0084H and 1084H are switched at boot swapping.
 2. To use the on-chip debug function with a product equipped with the on-chip debug function (μ PD78F0537D), set 02H or 03H to 0084H. Set a value that is the same as that of 0084H to 1084H because 0084H and 1084H are switched at boot swapping.

Remark For the on-chip debug security ID, see **CHAPTER 27 ON-CHIP DEBUG FUNCTION (μ PD78F0537D ONLY)**.

★ Here is an example of description of the software for setting the option bytes.

OPT	CSEG	AT 0080H	
OPTION:	DB	30H	; Enables watchdog timer operation (illegal access detection operation), ; Window open period of watchdog timer: 50%, ; Overflow time of watchdog timer: $2^{10}/f_{RL}$, ; Internal low-speed oscillator can be stopped by software.
	DB	00H	; 1.59 V POC mode
	DB	00H	; Reserved area
	DB	00H	; Reserved area
	DB	00H	; On-chip debug operation disabled

Remark Referencing of the option byte is performed during reset processing. For the reset processing timing, see **CHAPTER 22 RESET FUNCTION**.

CHAPTER 26 FLASH MEMORY

The 78K0/KE2 incorporates the flash memory to which a program can be written, erased, and overwritten while mounted on the board.

26.1 Internal Memory Size Switching Register

The internal memory capacity can be selected using the internal memory size switching register (IMS). IMS is set by an 8-bit memory manipulation instruction. Reset signal generation sets IMS to CFH.

Caution Be sure to set each product to the values shown in Table 26-1 after a reset release.

Figure 26-1. Format of Internal Memory Size Switching Register (IMS)

Address: FFF0H After reset: CFH R/W

Symbol	7	6	5	4	3	2	1	0
IMS	RAM2	RAM1	RAM0	0	ROM3	ROM2	ROM1	ROM0

RAM2	RAM1	RAM0	Internal high-speed RAM capacity selection	
0	0	0	768 bytes	
1	1	0	1024 bytes	
Other than above			Setting prohibited	

ROM3	ROM2	ROM1	ROM0	Internal ROM capacity selection
0	1	0	0	16 KB
0	1	1	0	24 KB
1	0	0	0	32 KB
1	1	0	0	48 KB
1	1	1	1	60 KB
Other than above				Setting prohibited

★ **Caution** To set the memory size, set IMS and then IXS. Set the memory size so that the internal ROM and internal expansion RAM areas do not overlap.

Table 26-1. Internal Memory Size Switching Register Settings

Flash Memory Versions (78K0/KE2)	IMS Setting
μ PD78F0531	04H
μ PD78F0532	C6H
μ PD78F0533	C8H
μ PD78F0534	CCH
μ PD78F0535	CFH
μ PD78F0536	CCH ^{Note}
μ PD78F0537, 78F0537D	CCH ^{Note}

Note The μ PD78F0536, μ PD78F0537, and 78F0537D have internal ROMs of 96 KB and 128 KB, respectively. However, the set values for the IMS of these devices is the same as those for the 48 KB product because memory banks are used. For how to set the memory banks, see **Figure 4-2 Format of Memory Bank Select Register (BANK)**.

26.2 Internal Expansion RAM Size Switching Register

The internal expansion RAM capacity can be selected using the internal expansion RAM size switching register (IXS).

IXS is set by an 8-bit memory manipulation instruction.

Reset signal generation sets IXS to 0CH.

Caution Be sure to set each product to the values shown in Table 26-2 after a reset release.

Figure 26-2. Format of Internal Expansion RAM Size Switching Register (IXS)

Address: FFF4H After reset: 0CH R/W

Symbol	7	6	5	4	3	2	1	0
IXS	0	0	0	IXRAM4	IXRAM3	IXRAM2	IXRAM1	IXRAM0

IXRAM4	IXRAM3	IXRAM2	IXRAM1	IXRAM0	Internal expansion RAM capacity selection
0	1	1	0	0	0 byte
0	1	0	1	0	1024 bytes
0	1	0	0	0	2048 bytes
0	0	1	0	0	4096 bytes
0	0	0	0	0	6144 bytes
Other than above					Setting prohibited

★ **Caution** To set memory size, set IMS and then IXS. Set memory size so that the internal ROM area and internal expansion RAM area do not overlap.

Table 26-2. Internal Expansion RAM Size Switching Register Settings

Flash Memory Versions (78K0/KE2)	IXS Setting
μPD78F0531	0CH
μPD78F0532	
μPD78F0533	
μPD78F0534	0AH
μPD78F0535	08H
μPD78F0536	04H
μPD78F0537, 78F0537D	00H

26.3 Writing with Flash Programmer

Data can be written to the flash memory on-board or off-board, by using a dedicated flash programmer.

(1) On-board programming

The contents of the flash memory can be rewritten after the 78K0/KE2 has been mounted on the target system. The connectors that connect the dedicated flash programmer must be mounted on the target system.

(2) Off-board programming

Data can be written to the flash memory with a dedicated program adapter (FA series) before the 78K0/KE2 is mounted on the target system.

Remark The FA series is a product of Naito Densai Machida Mfg. Co., Ltd.

Table 26-3. Wiring Between 78K0/KE2 and Dedicated Flash Programmer

Pin Configuration of Dedicated Flash Programmer			With CSI10		With UART6	
Signal Name	I/O	Pin Function	Pin Name	Pin No.	Pin Name	Pin No.
SI/RxD	Input	Receive signal	SO10/P12	44	TxD6/P13	43
SO/TxD	Output	Transmit signal	SI10/RxD0/P11	45	RxD6/P14	42
SCK	Output	Transfer clock	$\overline{\text{SCK10/TxD0/P10}}$	46	–	–
CLK	Output	Clock to 78K0/KE2	<small>Note 1</small>	–	EXCLK/X2/P122 ^{Note 2}	10
/RESET	Output	Reset signal	$\overline{\text{RESET}}$	6	$\overline{\text{RESET}}$	6
FLMD0	Output	Mode signal	FLMD0	9	FLMD0	9
V _{DD}	I/O	V _{DD} voltage generation/ power monitoring	V _{DD}	15	V _{DD}	15
			EV _{DD}	16	EV _{DD}	16
			AV _{REF}	47	AV _{REF}	47
GND	–	Ground	V _{SS}	13	V _{SS}	13
			EV _{SS}	14	EV _{SS}	14
			AV _{SS}	48	AV _{SS}	48

Notes 1. Only the internal high-speed oscillation clock (f_{RH}) can be used when CSI10 is used.

2. Only the X1 clock (f_x) or external main system clock (f_{EXCLK}) can be used when UART6 is used. When using the clock out of the flash programmer, connect CLK and EXCLK of the programmer.

Examples of the recommended connection when using the adapter for flash memory writing are shown below.

★ **Figure 26-3. Example of Wiring Adapter for Flash Memory Writing in 3-Wire Serial I/O (CSI10) Mode**

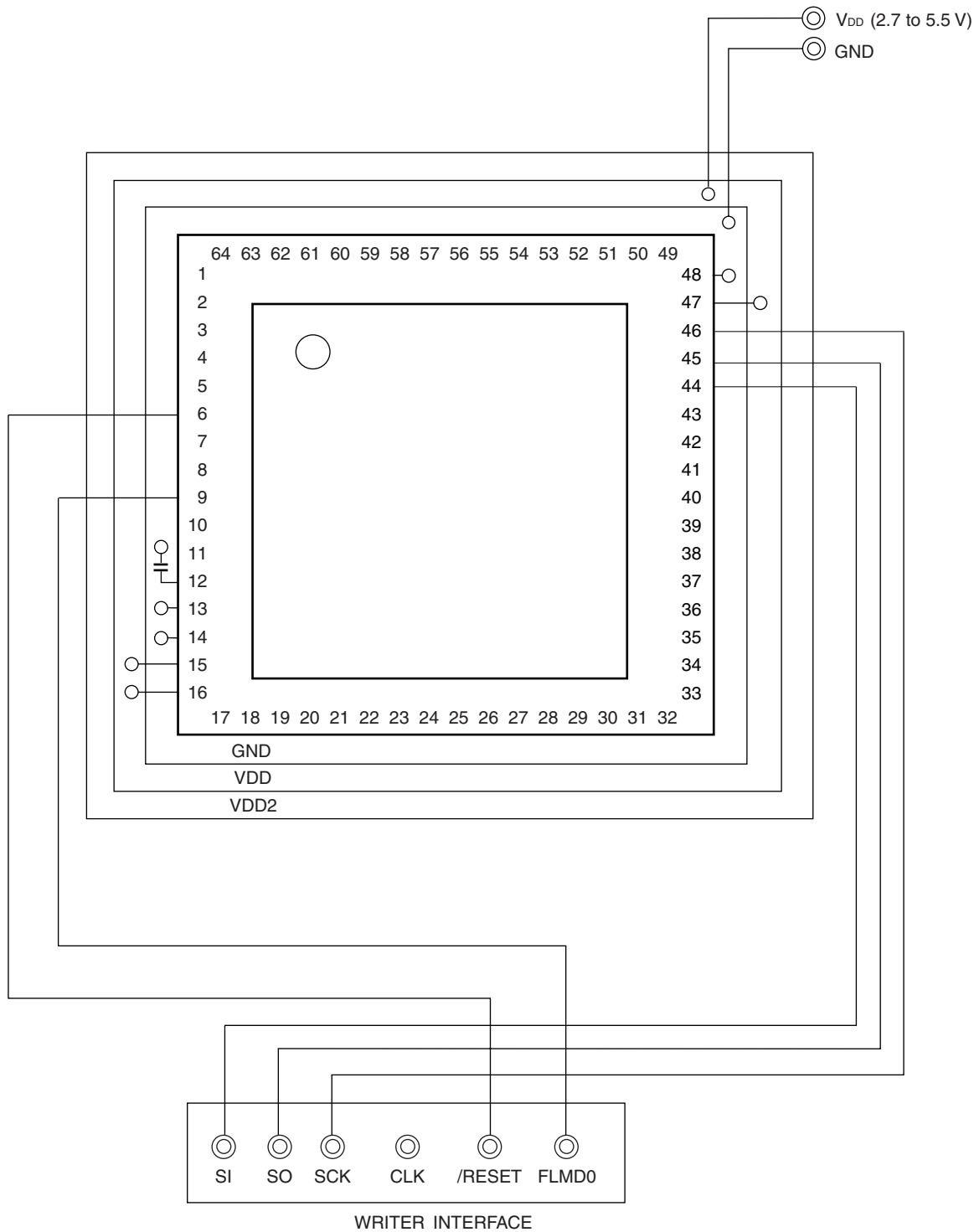

★

Figure 26-4. Example of Wiring Adapter for Flash Memory Writing in UART (UART6) Mode

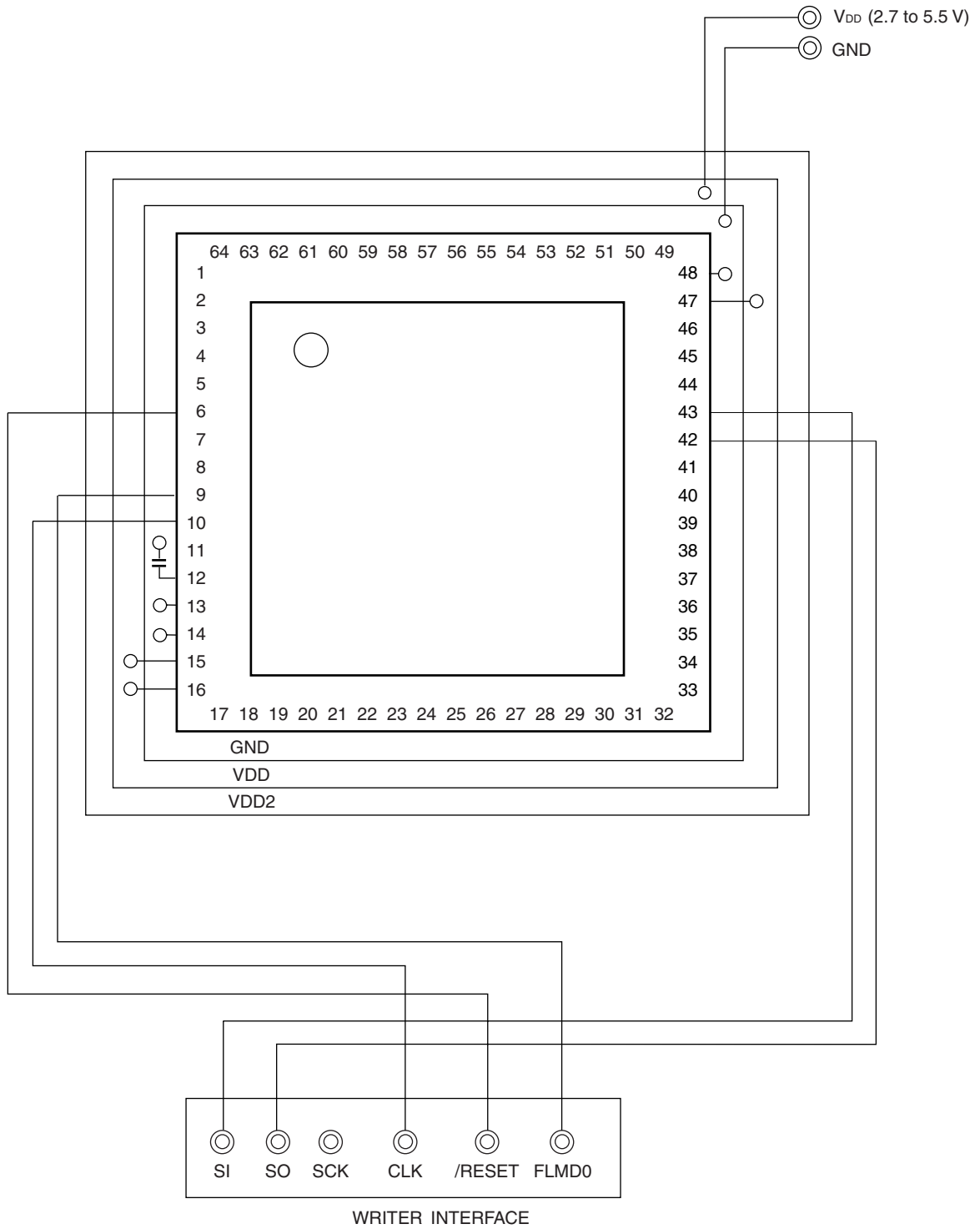

26.4 Programming Environment

The environment required for writing a program to the flash memory of the 78K0/KE2 is illustrated below.

Figure 26-5. Environment for Writing Program to Flash Memory

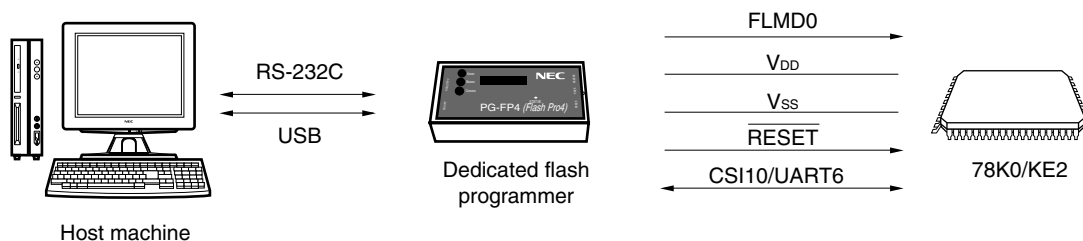

A host machine that controls the dedicated flash programmer is necessary.

To interface between the dedicated flash programmer and the 78K0/KE2, CSI10 or UART6 is used for manipulation such as writing and erasing. To write the flash memory off-board, a dedicated program adapter (FA series) is necessary.

26.5 Communication Mode

Communication between the dedicated flash programmer and the 78K0/KE2 is established by serial communication via CSI10 or UART6 of the 78K0/KE2.

(1) CSI10

- ★ Transfer rate: 2.4 kHz to 2.5 MHz

Figure 26-6. Communication with Dedicated Flash Programmer (CSI10)

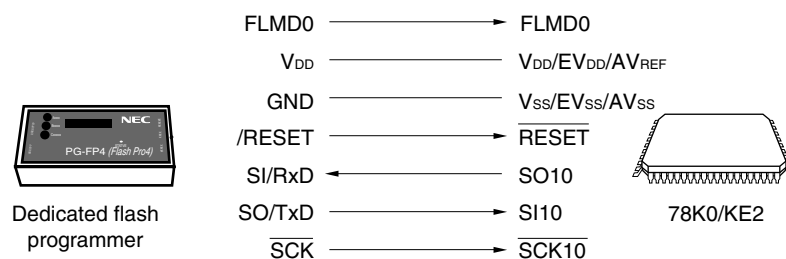

(2) UART6

★

Transfer rate: 115200 bps

Figure 26-7. Communication with Dedicated Flash Programmer (UART6)

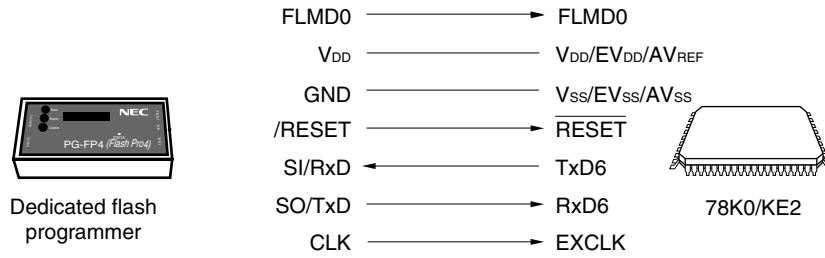

If FlashPro4 is used as the dedicated flash programmer, FlashPro4 generates the following signal for the 78K0/KE2. For details, refer to the FlashPro4 manual.

Table 26-4. Pin Connection

FlashPro4			78K0/KE2	Connection	
Signal Name	I/O	Pin Function	Pin Name	CSI10	UART6
FLMD0	Output	Mode signal	FLMD0	◎	◎
V _{DD}	I/O	V _{DD} voltage generation/power monitoring	V _{DD} , EV _{DD} , AV _{REF}	◎	◎
GND	—	Ground	V _{SS} , EV _{SS} , AV _{SS}	◎	◎
CLK	Output	Clock output to 78K0/KE2	EXCLK	× ^{Note 1}	○ ^{Note 2}
/RESET	Output	Reset signal	RESET	◎	◎
SI/RxD	Input	Receive signal	SO10/TxD6	◎	◎
SO/TxD	Output	Transmit signal	SI10/RxD6	◎	◎
SCK	Output	Transfer clock	SCK10	◎	×

Notes 1. Only the internal high-speed oscillation clock (f_{RH}) can be used when CSI10 is used.

2. Only the X1 clock (f_x) or external main system clock (f_{EXCLK}) can be used when UART6 is used. When using the clock out of the flash programmer, connect CLK and EXCLK of the programmer.

Remark ◎: Be sure to connect the pin.

○: The pin does not have to be connected if the signal is generated on the target board.

×: The pin does not have to be connected.

26.6 Handling of Pins on Board

To write the flash memory on-board, connectors that connect the dedicated flash programmer must be provided on the target system. First provide a function that selects the normal operation mode or flash memory programming mode on the board.

When the flash memory programming mode is set, all the pins not used for programming the flash memory are in the same status as immediately after reset. Therefore, if the external device does not recognize the state immediately after reset, the pins must be handled as described below.

26.6.1 FLMD0 pin

In the normal operation mode, 0 V is input to the FLMD0 pin. In the flash memory programming mode, the V_{DD} write voltage is supplied to the FLMD0 pin. An FLMD0 pin connection example is shown below.

Figure 26-8. FLMD0 Pin Connection Example

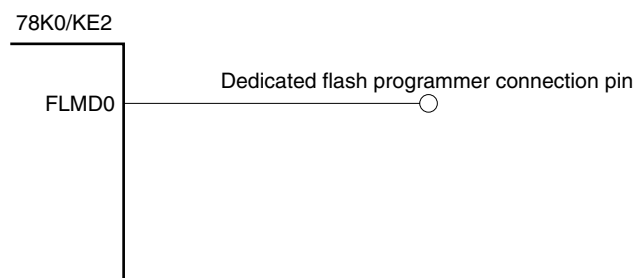

26.6.2 Serial interface pins

The pins used by each serial interface are listed below.

Table 26-5. Pins Used by Each Serial Interface

Serial Interface	Pins Used
CSI10	SO10, SI10, $\overline{SCK10}$
UART6	TxD6, RxD6

To connect the dedicated flash programmer to the pins of a serial interface that is connected to another device on the board, care must be exercised so that signals do not collide or that the other device does not malfunction.

(1) Signal collision

If the dedicated flash programmer (output) is connected to a pin (input) of a serial interface connected to another device (output), signal collision takes place. To avoid this collision, either isolate the connection with the other device, or make the other device go into an output high-impedance state.

Figure 26-9. Signal Collision (Input Pin of Serial Interface)

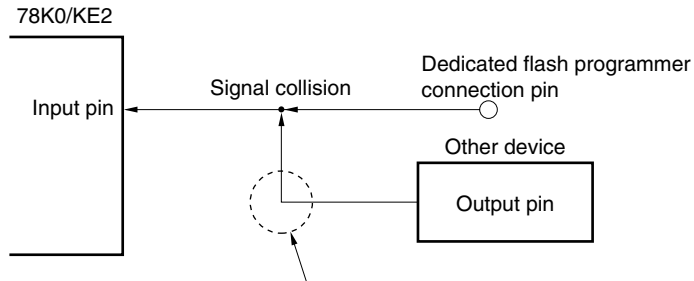

In the flash memory programming mode, the signal output by the device collides with the signal sent from the dedicated flash programmer. Therefore, isolate the signal of the other device.

(2) Malfunction of other device

If the dedicated flash programmer (output or input) is connected to a pin (input or output) of a serial interface connected to another device (input), a signal may be output to the other device, causing the device to malfunction. To avoid this malfunction, isolate the connection with the other device.

Figure 26-10. Malfunction of Other Device

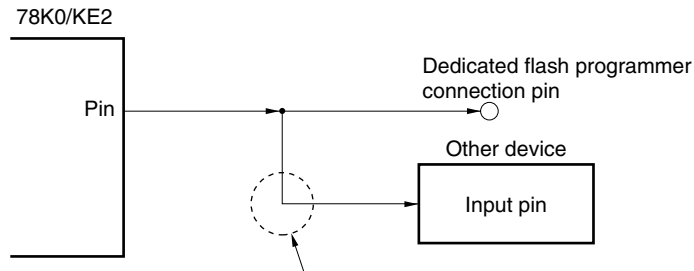

If the signal output by the 78K0/KE2 in the flash memory programming mode affects the other device, isolate the signal of the other device.

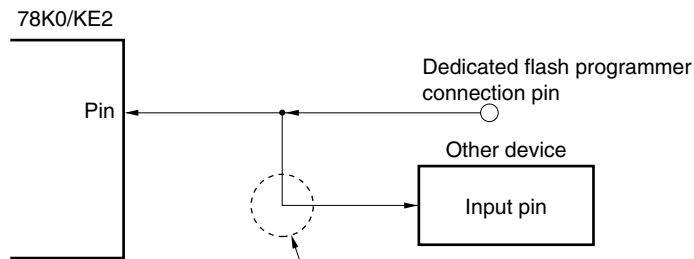

If the signal output by the dedicated flash programmer in the flash memory programming mode affects the other device, isolate the signal of the other device.

26.6.3 $\overline{\text{RESET}}$ pin

If the reset signal of the dedicated flash programmer is connected to the $\overline{\text{RESET}}$ pin that is connected to the reset signal generator on the board, signal collision takes place. To prevent this collision, isolate the connection with the reset signal generator.

If the reset signal is input from the user system while the flash memory programming mode is set, the flash memory will not be correctly programmed. Do not input any signal other than the reset signal of the dedicated flash programmer.

Figure 26-11. Signal Collision ($\overline{\text{RESET}}$ Pin)

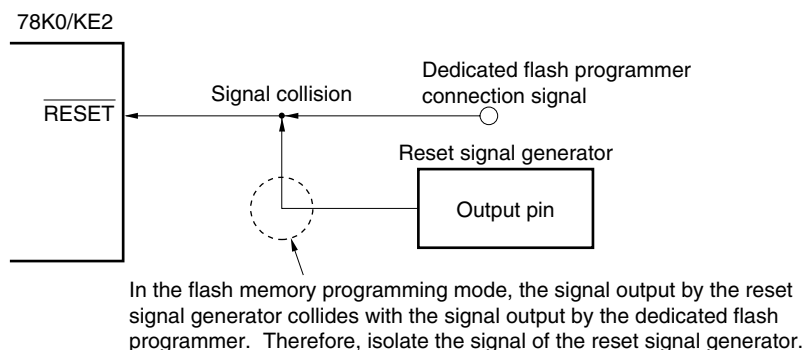

26.6.4 Port pins

When the flash memory programming mode is set, all the pins not used for flash memory programming enter the same status as that immediately after reset. If external devices connected to the ports do not recognize the port status immediately after reset, the port pin must be connected to V_{DD} or V_{SS} via a resistor.

26.6.5 REGC pin

Connect the REGC pin to GND via a capacitor (0.47 μF : target) in the same manner as during normal operation.

26.6.6 Other signal pins

Connect X1 and X2 in the same status as in the normal operation mode when using the on-board clock.

To input the operating clock from the programmer, however, connect the clock out of the programmer to EXCLK.

- Cautions**
1. Only the internal high-speed oscillation clock (f_{RH}) can be used when CSI10 is used.
 2. Only the X1 clock (f_x) or external main system clock (f_{EXCLK}) can be used when UART6 is used.

26.6.7 Power supply

To use the supply voltage output of the flash programmer, connect the V_{DD} pin to V_{DD} of the flash programmer, and the V_{SS} pin to GND of the flash programmer.

However, be sure to connect the V_{DD} and V_{SS} pins to V_{DD} and GND of the flash programmer to use the power monitor function with the flash programmer.

To use the on-board supply voltage, connect in compliance with the normal operation mode.

Supply the same other power supplies (EV_{DD} , EV_{SS} , AV_{REF} , and AV_{SS}) as those in the normal operation mode.

26.7 Programming Method

26.7.1 Controlling flash memory

The following figure illustrates the procedure to manipulate the flash memory.

Figure 26-12. Flash Memory Manipulation Procedure

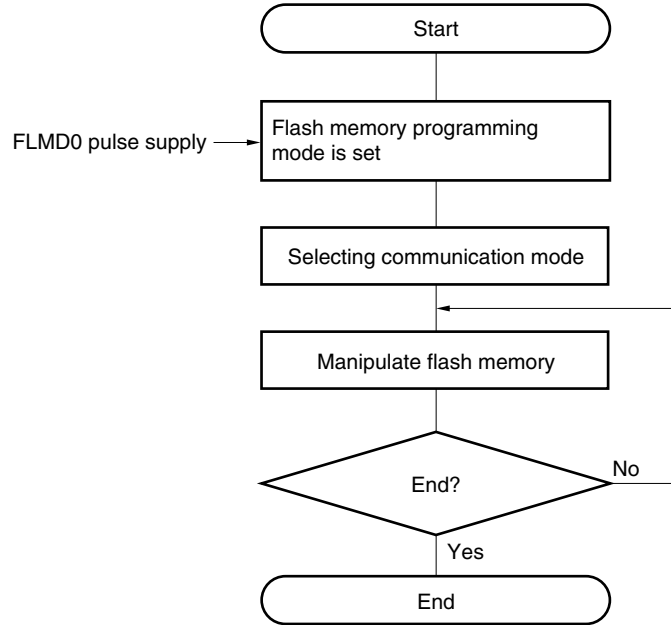

26.7.2 Flash memory programming mode

To rewrite the contents of the flash memory by using the dedicated flash programmer, set the 78K0/KE2 in the flash memory programming mode. To set the mode, set the FLMDO pin to V_{DD} and clear the reset signal.

Change the mode by using a jumper when writing the flash memory on-board.

Figure 26-13. Flash Memory Programming Mode

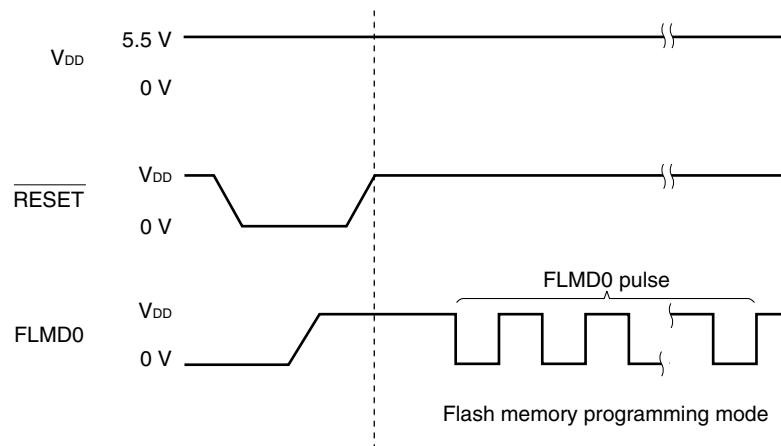

Table 26-6. Relationship Between FLMDO Pin and Operation Mode After Reset Release

FLMDO	Operation Mode
0	Normal operation mode
V_{DD}	Flash memory programming mode

26.7.3 Selecting communication mode

In the 78K0/KE2, a communication mode is selected by inputting pulses (up to 11 pulses) to the FLMD0 pin after the dedicated flash memory programming mode is entered. These FLMD0 pulses are generated by the flash programmer.

The following table shows the relationship between the number of pulses and communication modes.

★

Table 26-7. Communication Modes

Communication Mode	Standard Setting ^{Note 1}					Pins Used	Peripheral Clock	Number of FLMD0 Pulses
	Port	Speed	On Target	Frequency	Multiply Rate			
UART (UART6)	UART-ch0	115200 bps ^{Note 3}	Optional	1 to 20 MHz ^{Note 2}	1.0	TxD6, RxD6	f _X	0
							f _{EXCLK}	3
3-wire serial I/O (CSI10)	SIO-ch0	2.4 kHz to 2.5 MHz				SO10, SI10, SCK10	f _{RH}	8

- Notes**
1. Selection items for Standard settings on FlashPro4.
 2. The possible setting range differs depending on the voltage. For details, refer to the chapter of electrical specifications.
 3. Because factors other than the baud rate error, such as the signal waveform slew, also affect UART communication, thoroughly evaluate the slew as well as the baud rate error.

Caution When UART6 is selected, the receive clock is calculated based on the reset command sent from the dedicated flash programmer after the FLMD0 pulse has been received.

Remark

f_X: X1 clock
 f_{EXCLK}: External main system clock
 f_{RH}: Internal high-speed oscillation clock

26.7.4 Communication commands

The 78K0/KE2 communicates with the dedicated flash programmer by using commands. The signals sent from the flash programmer to the 78K0/KE2 are called commands, and the signals sent from the 78K0/KE2 to the dedicated flash programmer are called response.

Figure 26-14. Communication Commands

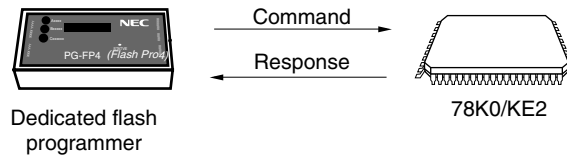

The flash memory control commands of the 78K0/KE2 are listed in the table below. All these commands are issued from the programmer and the 78K0/KE2 perform processing corresponding to the respective commands.

Table 26-8. Flash Memory Control Commands

Classification	Command Name	Function
Verify	Batch verify command	Compares the contents of the entire memory with the input data.
Erase	Batch erase command	Erases the contents of the entire memory.
Blank check	Batch blank check command	Checks the erasure status of the entire memory.
Data write	High-speed write command	Writes data by specifying the write address and number of bytes to be written, and executes a verify check.
	Successive write command	Writes data from the address following that of the high-speed write command executed immediately before, and executes a verify check.
System setting, control	Status read command	Obtains the operation status
	Oscillation frequency setting command	Sets the oscillation frequency
	Erase time setting command	Sets the erase time for batch erase
	Write time setting command	Sets the write time for writing data
	Baud rate setting command	Sets the baud rate when UART is used
	Silicon signature command	Reads the silicon signature information
	Reset command	Escapes from each status

The 78K0/KE2 return a response for the command issued by the dedicated flash programmer. The response names sent from the 78K0/KE2 are listed below.

Table 26-9. Response Names

Response Name	Function
ACK	Acknowledges command/data.
NAK	Acknowledges illegal command/data.

★ 26.8 Security Settings

The operations shown below can be performed using the security setting command. The security setting is valid when the programming mode is set next.

- Disabling batch erase (chip erase)
Execution of the block erase and batch erase (chip erase) commands for entire blocks in the flash memory is prohibited by this setting. Once execution of the batch erase (chip erase) command is prohibited, all of the prohibition settings can no longer be cancelled.

Caution After the security setting for the batch erase is set, erasure cannot be performed for the device. In addition, even if a write command is executed, data different from that which has already been written to the flash memory cannot be written, because the erase command is disabled.

- Disabling block erase
Execution of the block erase command for a specific block in the flash memory is prohibited by this setting. This prohibition setting can be cancelled using the batch erase (chip erase) command.
- Disabling write
Execution of the write and block erase commands for entire blocks in the flash memory is prohibited by this setting. This prohibition setting can be cancelled using the batch erase (chip erase) command.
- Disabling rewriting boot cluster 0
Execution of the batch erase (chip erase) command, block erase command, and write command on boot cluster 0 (0000H to 0FFFH) in the flash memory is prohibited by this setting.

Caution If a security setting that rewrites boot cluster 0 has been applied, boot cluster 0 of that device will not be rewritten.

The batch erase (chip erase), block erase, write commands, and rewriting boot cluster 0 are enabled by the default setting when the flash memory is shipped. The above security settings are only possible for on-board/off-board programming. Each security setting can be used in combination.

Table 26-10 shows the relationship between the erase and write commands when the 78K0/KE2 security function is enabled.

Table 26-10. Relationship Between Commands When Security Function Is Enabled

Security Setting \ Command	Batch Erase (Chip Erase) Command	Block Erase Command	Write Command
Disabling batch erase (chip erase)	Invalid	Invalid	Valid ^{Note}
Disabling block erase	Valid		Valid
Disabling write			Invalid
Disabling rewriting boot cluster 0	Invalid		

Note Since the erase command is disabled, data different from that which has already been written to the flash memory cannot be written.

Table 26-11 shows the relationship between the security setting and the operation in each programming mode.

Table 26-11. Relationship Between Security Setting and Operation In Each Programming Mode

Programming Mode Security Setting	On-Board/Off-Board Programming		Self Programming	
	Security Setting	Security Operation	Security Setting	Security Operation
Disabling batch erase (chip erase)	Enabled	Valid ^{Note 1}	Disabled	Invalid ^{Note 2}
Disabling block erase				
Disabling write				
Disabling rewriting boot cluster 0			Enabled	Valid

- Notes**
1. Execution of each command is prohibited by the security setting.
 2. Execution of self programming command is possible regardless of the security setting.

26.9 Flash Memory Programming by Self-Programming

The 78K0/KE2 supports a self-programming function that can be used to rewrite the flash memory via a user program. Because this function allows a user application to rewrite the flash memory by using the 78K0/KE2 self-programming library, it can be used to upgrade the program in the field.

If an interrupt occurs during self-programming, self-programming can be temporarily stopped and interrupt servicing can be executed. To execute interrupt servicing, restore the normal operation mode after self-programming has been stopped, and execute the EI instruction. After the self-programming mode is later restored, self-programming can be resumed.

Remark For details of the self-programming function and the 78K0/KE2 self-programming library, refer to a separate document to be published (document name: 78K0/Kx2 Application Note, release schedule: Pending).

- Cautions**
1. The self-programming function cannot be used when the CPU operates with the subsystem clock.
 2. Input a high level to the FLMD0 pin during self-programming.
 3. Be sure to execute the DI instruction before starting self-programming. The self-programming function checks the interrupt request flags (IF0L, IF0H, IF1L, and IF1H). If an interrupt request is generated, self-programming is stopped.
 4. Self-programming is also stopped by an interrupt request that is not masked even in the DI status. To prevent this, mask the interrupt by using the interrupt mask flag registers (MK0L, MK0H, MK1L, and MK1H).
 5. Self-programming is executed with the internal high-speed oscillation clock. If the CPU operates with the X1 clock or external main system clock, the oscillation stabilization wait time of the internal high-speed oscillation clock elapses during self-programming.
 6. Allocate the entry program for self-programming in the common area of 0000H to 7FFFH.

Figure 26-15. Operation Mode and Memory Map for Self-Programming (μ PD78F0537)

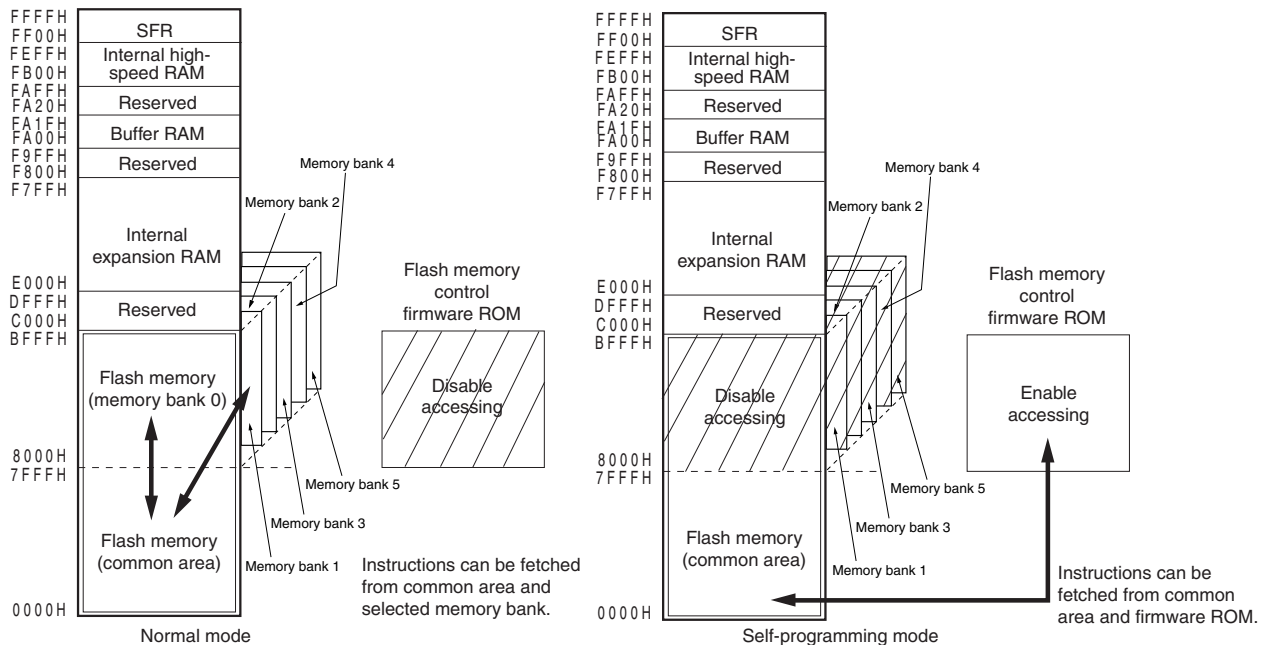

The procedure of self-programming is illustrated below.

Figure 26-16. Self-Programming Procedure

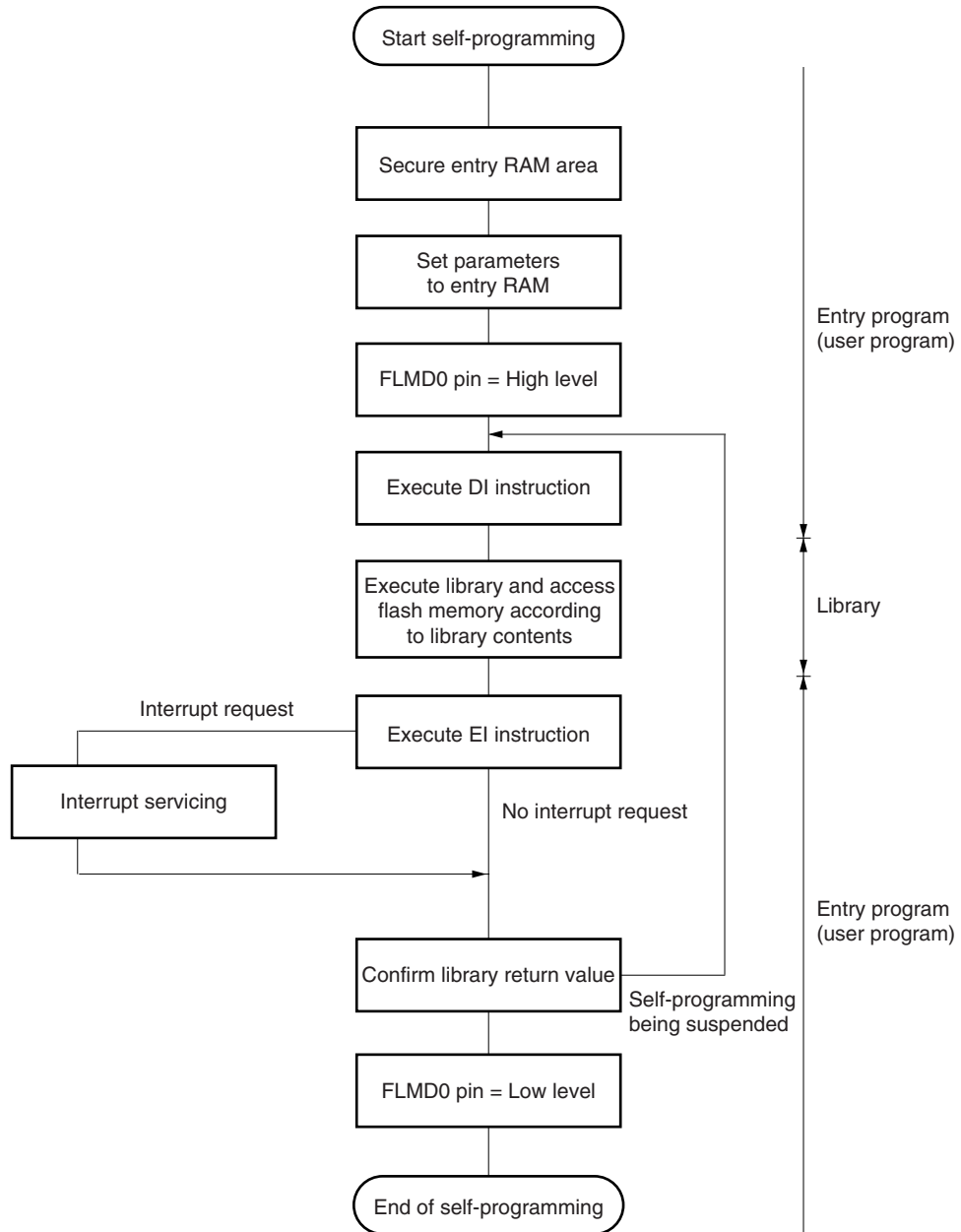

★ 26.9.1 Boot swap function

If rewriting the boot area has failed during self-programming due to a power failure or some other cause, the data in the boot area may be lost and the program may not be restarted by resetting.

The boot swap function is used to avoid this problem.

Before erasing boot cluster 0^{Note}, which is a boot program area, by self-programming, write a new boot program to boot cluster 1 in advance. When the program has been correctly written to boot cluster 1, swap this boot cluster 1 and boot cluster 0 by using the set information function of the firmware of the 78K0/KE2, so that boot cluster 1 is used as a boot area. After that, erase or write the original boot program area, boot cluster 0.

As a result, even if a power failure occurs while the boot programming area is being rewritten, the program is executed correctly because it is booted from boot cluster 1 to be swapped when the program is reset and started next.

If the program has been correctly written to boot cluster 0, restore the original boot area by using the set information function of the firmware of the 78K0/KE2.

Note A boot cluster is a 4 KB area and boot clusters 0 and 1 are swapped by the boot swap function.

Boot cluster 0 (0000H to 0FFFH): Original boot program area

Boot cluster 1 (1000H to 1FFFH): Area subject to boot swap function

Figure 26-17. Boot Swap Function

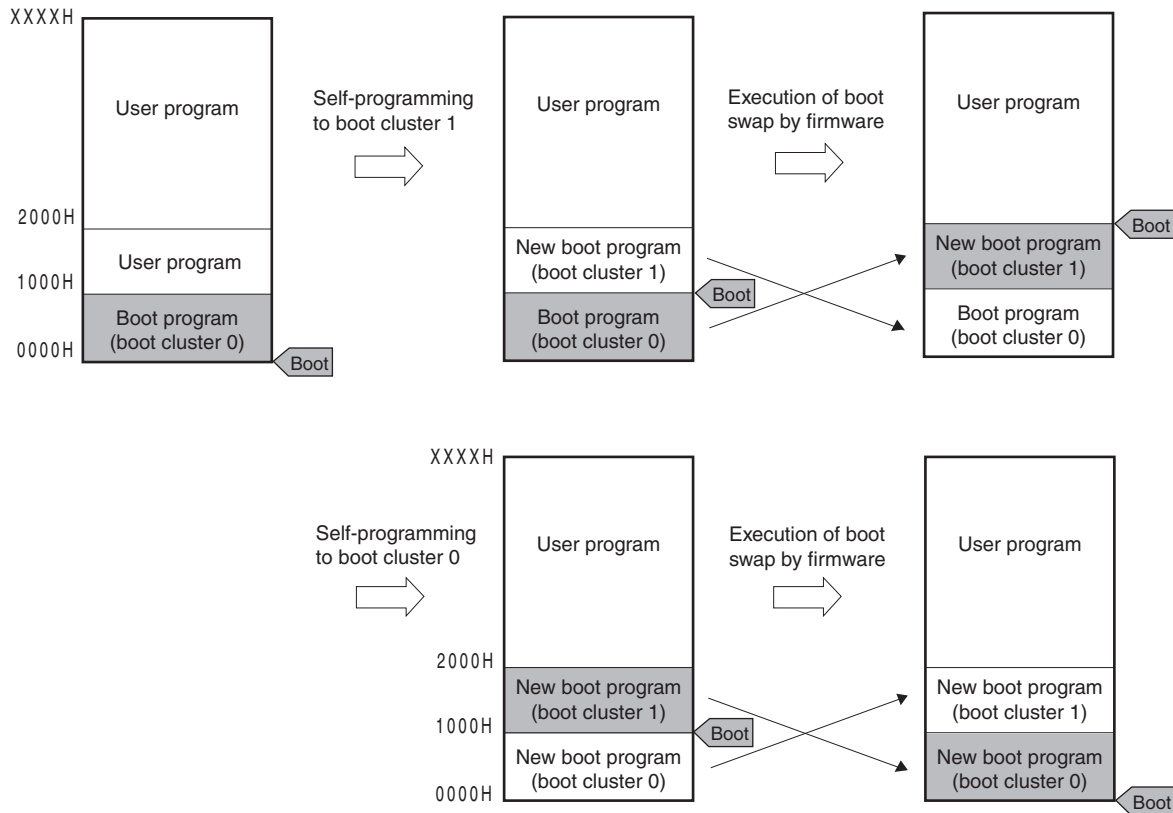

★

Figure 26-18. Example of Executing Boot Swapping

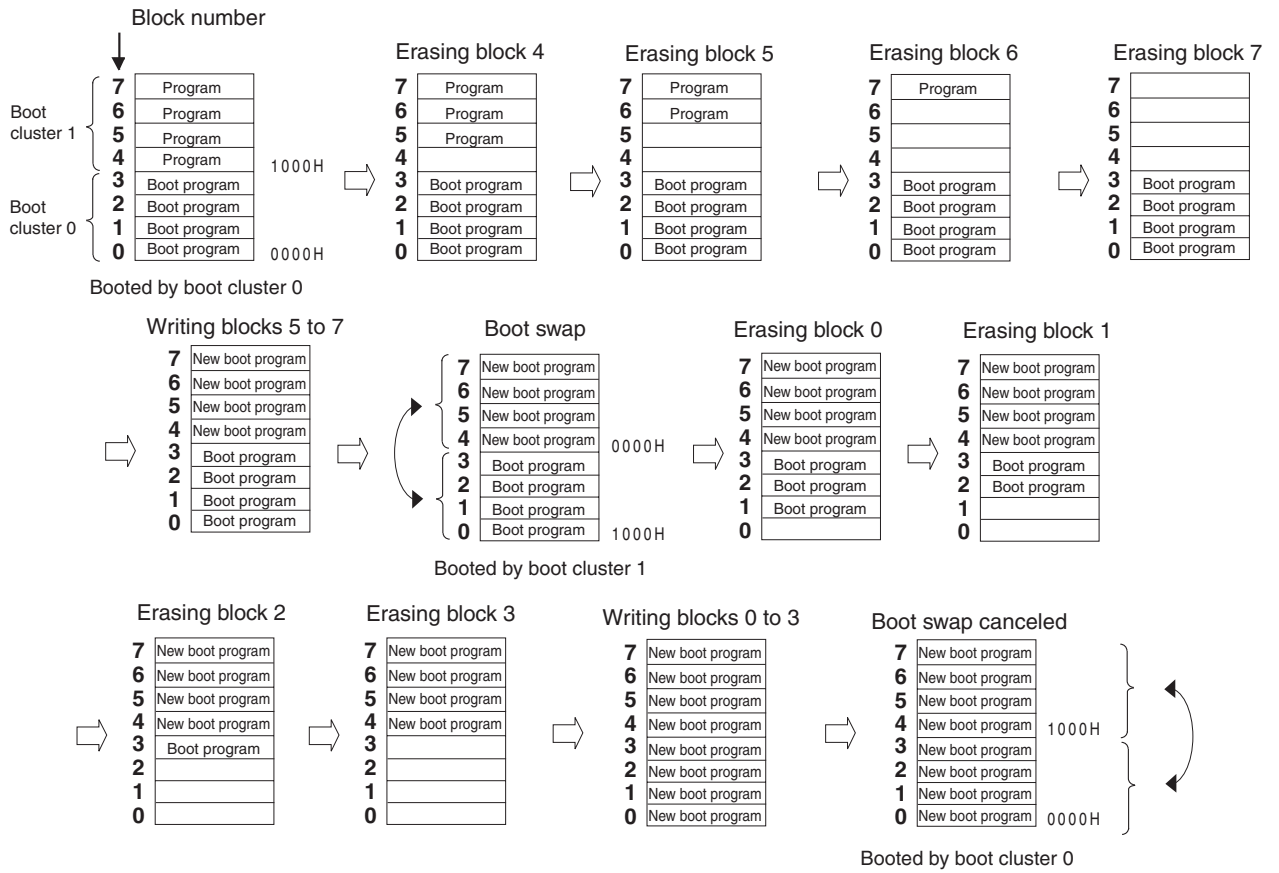

CHAPTER 27 ON-CHIP DEBUG FUNCTION (μ PD78F0537D ONLY)

The μ PD78F0537D uses the V_{DD} , FLMD0, $\overline{\text{RESET}}$, OCD0A/X1 (or OCD1A/P31), OCD0B/X2 (or OCD1B/P32), and V_{SS} pins to communicate with the host machine via an on-chip debug emulator (QB-78K0MINI). Whether OCD0A/X1 and OCD1A/P31, or OCD0B/X2 and OCD1B/P32 are used can be selected.

Caution The μ PD78F0537D has an on-chip debug function. Do not use this product for mass production because its reliability cannot be guaranteed after the on-chip debug function has been used, given the issue of the number of times the flash memory can be rewritten. NEC Electronics does not accept complaints concerning this product.

**Figure 27-1. Connection Example of QB-78K0MINI and μ PD78F0537D
(When OCD0A/X1 and OCD0B/X2 Are Used)**

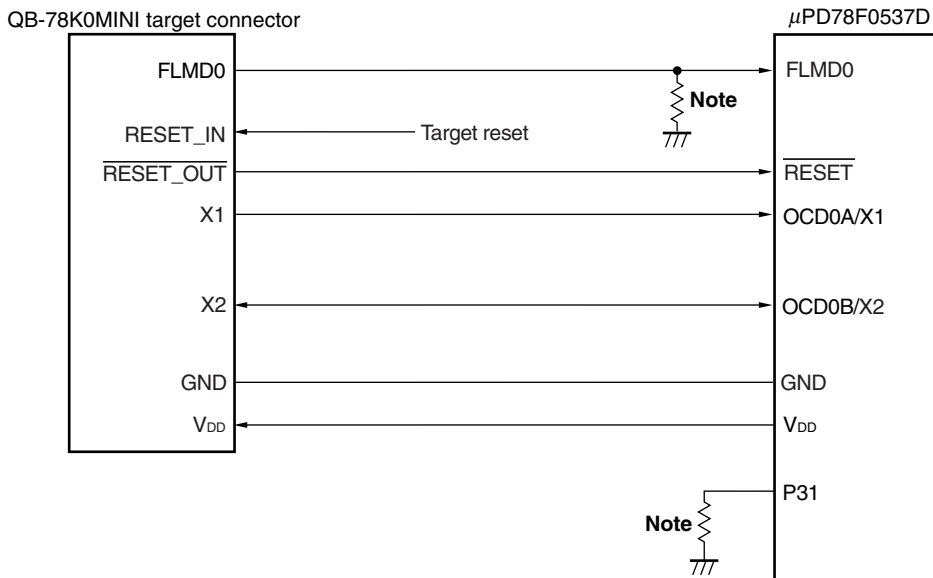

Note Make pull-down resistor 470 Ω or more.

- Cautions**
1. Input the clock from the OCD0A/X1 pin during on-chip debugging.
 2. Control the OCD0A/X1 and OCD0B/X2 pins by externally pulling down the OCD1A/P31 pin or by using an external circuit using the P130 pin (that outputs a low level when the device is reset).

Figure 27-2. Connection Example of QB-78K0MINI and μPD78F0537D (When OCD1A and OCD1B Are Used)

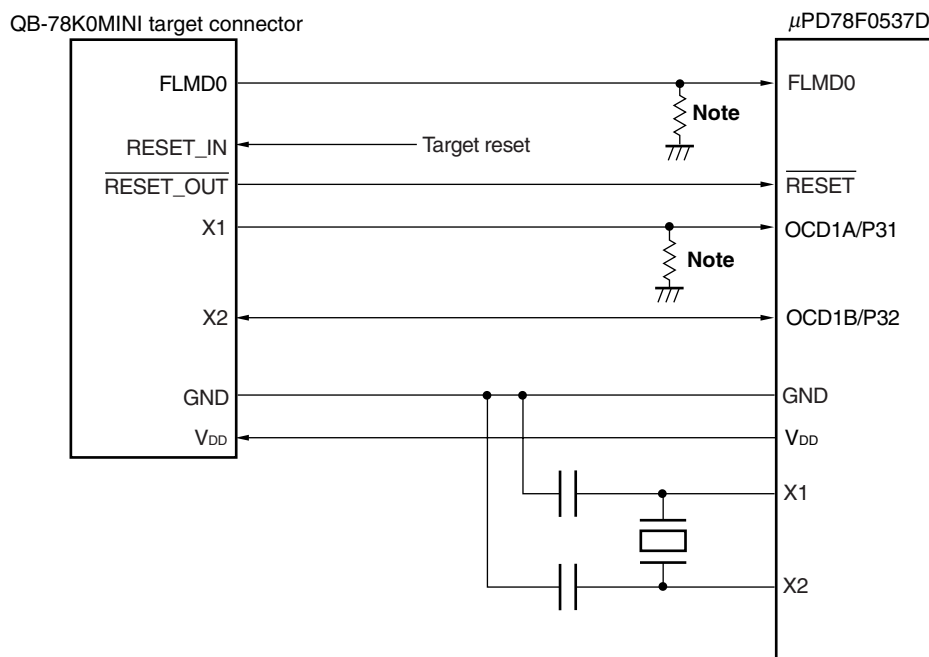

Note Make pull-down resistor 470 Ω or more.

27.1 On-Chip Debug Security ID

The μPD78F0537D has an on-chip debug operation control flag in the flash memory at 0084H (see **CHAPTER 25 OPTION BYTE**) and an on-chip debug security ID setting area at 0085H to 008EH.

When the boot swap function is used, also set a value that is the same as that of 1084H and 1085H to 108EH in advance, because 0084H, 0085H to 008EH and 1084H, and 1085H to 108EH are switched.

For details on the on-chip debug security ID, refer to the QB-78K0MINI User's Manual (U17029E).

Table 27-1. On-Chip Debug Security ID

Address	On-Chip Debug Security ID
0085H to 008EH	Any ID code of 10 bytes
1085H to 108EH	

CHAPTER 28 INSTRUCTION SET

This chapter lists each instruction set of the 78K0/KE2 in table form. For details of each operation and operation code, refer to the separate document **78K/0 Series Instructions User's Manual (U12326E)**.

28.1 Conventions Used in Operation List

28.1.1 Operand identifiers and specification methods

Operands are written in the "Operand" column of each instruction in accordance with the specification method of the instruction operand identifier (refer to the assembler specifications for details). When there are two or more methods, select one of them. Uppercase letters and the symbols #, !, \$ and [] are keywords and must be written as they are. Each symbol has the following meaning.

- #: Immediate data specification
- !: Absolute address specification
- \$: Relative address specification
- []: Indirect address specification

In the case of immediate data, describe an appropriate numeric value or a label. When using a label, be sure to write the #, !, \$, and [] symbols.

For operand register identifiers r and rp, either function names (X, A, C, etc.) or absolute names (names in parentheses in the table below, R0, R1, R2, etc.) can be used for specification.

Table 28-1. Operand Identifiers and Specification Methods

Identifier	Specification Method
r	X (R0), A (R1), C (R2), B (R3), E (R4), D (R5), L (R6), H (R7)
rp	AX (RP0), BC (RP1), DE (RP2), HL (RP3)
sfr	Special function register symbol ^{Note}
sfrp	Special function register symbol (16-bit manipulatable register even addresses only) ^{Note}
saddr	FE20H to FF1FH Immediate data or labels
saddrp	FE20H to FF1FH Immediate data or labels (even address only)
addr16	0000H to FFFFH Immediate data or labels (Only even addresses for 16-bit data transfer instructions)
addr11	0800H to 0FFFH Immediate data or labels
addr5	0040H to 007FH Immediate data or labels (even address only)
word	16-bit immediate data or label
byte	8-bit immediate data or label
bit	3-bit immediate data or label
RBn	RB0 to RB3

Note Addresses from FFD0H to FFDFH cannot be accessed with these operands.

Remark For special function register symbols, see **Table 3-6 Special Function Register List**.

28.1.2 Description of operation column

A:	A register; 8-bit accumulator
X:	X register
B:	B register
C:	C register
D:	D register
E:	E register
H:	H register
L:	L register
AX:	AX register pair; 16-bit accumulator
BC:	BC register pair
DE:	DE register pair
HL:	HL register pair
PC:	Program counter
SP:	Stack pointer
PSW:	Program status word
CY:	Carry flag
AC:	Auxiliary carry flag
Z:	Zero flag
RBS:	Register bank select flag
IE:	Interrupt request enable flag
():	Memory contents indicated by address or register contents in parentheses
X _H , X _L :	Higher 8 bits and lower 8 bits of 16-bit register
∧:	Logical product (AND)
∨:	Logical sum (OR)
⊕:	Exclusive logical sum (exclusive OR)
⎯:	Inverted data
addr16:	16-bit immediate data or label
jdsp8:	Signed 8-bit data (displacement value)

28.1.3 Description of flag operation column

(Blank):	Not affected
0:	Cleared to 0
1:	Set to 1
×	Set/cleared according to the result
R:	Previously saved value is restored

28.2 Operation List

Instruction Group	Mnemonic	Operands	Bytes	Clocks		Operation	Flag			
				Note 1	Note 2		Z	AC	CY	
8-bit data transfer	MOV	r, #byte	2	4	–	r ← byte				
		saddr, #byte	3	6	7	(saddr) ← byte				
		sfr, #byte	3	–	7	sfr ← byte				
		A, r	Note 3	1	2	–	A ← r			
		r, A	Note 3	1	2	–	r ← A			
		A, saddr		2	4	5	A ← (saddr)			
		saddr, A		2	4	5	(saddr) ← A			
		A, sfr		2	–	5	A ← sfr			
		sfr, A		2	–	5	sfr ← A			
		A, !addr16		3	8	9	A ← (addr16)			
		!addr16, A		3	8	9	(addr16) ← A			
		PSW, #byte		3	–	7	PSW ← byte	×	×	×
		A, PSW		2	–	5	A ← PSW			
		PSW, A		2	–	5	PSW ← A	×	×	×
		A, [DE]		1	4	5	A ← (DE)			
		[DE], A		1	4	5	(DE) ← A			
		A, [HL]		1	4	5	A ← (HL)			
		[HL], A		1	4	5	(HL) ← A			
		A, [HL + byte]		2	8	9	A ← (HL + byte)			
		[HL + byte], A		2	8	9	(HL + byte) ← A			
	A, [HL + B]		1	6	7	A ← (HL + B)				
	[HL + B], A		1	6	7	(HL + B) ← A				
	A, [HL + C]		1	6	7	A ← (HL + C)				
	[HL + C], A		1	6	7	(HL + C) ← A				
	XCH	A, r	Note 3	1	2	–	A ↔ r			
		A, saddr		2	4	6	A ↔ (saddr)			
		A, sfr		2	–	6	A ↔ (sfr)			
		A, !addr16		3	8	10	A ↔ (addr16)			
		A, [DE]		1	4	6	A ↔ (DE)			
		A, [HL]		1	4	6	A ↔ (HL)			
		A, [HL + byte]		2	8	10	A ↔ (HL + byte)			
		A, [HL + B]		2	8	10	A ↔ (HL + B)			
A, [HL + C]		2	8	10	A ↔ (HL + C)					

- Notes**
1. When the internal high-speed RAM area is accessed or for an instruction with no data access
 2. When an area except the internal high-speed RAM area is accessed
 3. Except “r = A”

- Remarks**
1. One instruction clock cycle is one cycle of the CPU clock (f_{CPU}) selected by the processor clock control register (PCC).
 2. This clock cycle applies to the internal ROM program.

Instruction Group	Mnemonic	Operands	Bytes	Clocks		Operation	Flag		
				Note 1	Note 2		Z	AC	CY
16-bit data transfer	MOVW	rp, #word	3	6	–	rp ← word			
		saddrp, #word	4	8	10	(saddrp) ← word			
		sfrp, #word	4	–	10	sfrp ← word			
		AX, saddrp	2	6	8	AX ← (saddrp)			
		saddrp, AX	2	6	8	(saddrp) ← AX			
		AX, sfrp	2	–	8	AX ← sfrp			
		sfrp, AX	2	–	8	sfrp ← AX			
		AX, rp <small>Note 3</small>	1	4	–	AX ← rp			
		rp, AX <small>Note 3</small>	1	4	–	rp ← AX			
		AX, !addr16	3	10	12	AX ← (addr16)			
!addr16, AX	3	10	12	(addr16) ← AX					
	XCHW	AX, rp <small>Note 3</small>	1	4	–	AX ↔ rp			
8-bit operation	ADD	A, #byte	2	4	–	A, CY ← A + byte	x	x	x
		saddr, #byte	3	6	8	(saddr), CY ← (saddr) + byte	x	x	x
		A, r <small>Note 4</small>	2	4	–	A, CY ← A + r	x	x	x
		r, A	2	4	–	r, CY ← r + A	x	x	x
		A, saddr	2	4	5	A, CY ← A + (saddr)	x	x	x
		A, !addr16	3	8	9	A, CY ← A + (addr16)	x	x	x
		A, [HL]	1	4	5	A, CY ← A + (HL)	x	x	x
		A, [HL + byte]	2	8	9	A, CY ← A + (HL + byte)	x	x	x
		A, [HL + B]	2	8	9	A, CY ← A + (HL + B)	x	x	x
	A, [HL + C]	2	8	9	A, CY ← A + (HL + C)	x	x	x	
	ADDC	A, #byte	2	4	–	A, CY ← A + byte + CY	x	x	x
		saddr, #byte	3	6	8	(saddr), CY ← (saddr) + byte + CY	x	x	x
		A, r <small>Note 4</small>	2	4	–	A, CY ← A + r + CY	x	x	x
		r, A	2	4	–	r, CY ← r + A + CY	x	x	x
		A, saddr	2	4	5	A, CY ← A + (saddr) + CY	x	x	x
		A, !addr16	3	8	9	A, CY ← A + (addr16) + C	x	x	x
		A, [HL]	1	4	5	A, CY ← A + (HL) + CY	x	x	x
		A, [HL + byte]	2	8	9	A, CY ← A + (HL + byte) + CY	x	x	x
A, [HL + B]		2	8	9	A, CY ← A + (HL + B) + CY	x	x	x	
A, [HL + C]	2	8	9	A, CY ← A + (HL + C) + CY	x	x	x		

- Notes**
1. When the internal high-speed RAM area is accessed or for an instruction with no data access
 2. When an area except the internal high-speed RAM area is accessed
 3. Only when rp = BC, DE or HL
 4. Except “r = A”

- Remarks**
1. One instruction clock cycle is one cycle of the CPU clock (f_{CPU}) selected by the processor clock control register (PCC).
 2. This clock cycle applies to the internal ROM program.

Instruction Group	Mnemonic	Operands	Bytes	Clocks		Operation	Flag		
				Note 1	Note 2		Z	AC	CY
8-bit operation	SUB	A, #byte	2	4	–	A, CY ← A – byte	x	x	x
		saddr, #byte	3	6	8	(saddr), CY ← (saddr) – byte	x	x	x
		A, r <small>Note 3</small>	2	4	–	A, CY ← A – r	x	x	x
		r, A	2	4	–	r, CY ← r – A	x	x	x
		A, saddr	2	4	5	A, CY ← A – (saddr)	x	x	x
		A, !addr16	3	8	9	A, CY ← A – (addr16)	x	x	x
		A, [HL]	1	4	5	A, CY ← A – (HL)	x	x	x
		A, [HL + byte]	2	8	9	A, CY ← A – (HL + byte)	x	x	x
		A, [HL + B]	2	8	9	A, CY ← A – (HL + B)	x	x	x
		A, [HL + C]	2	8	9	A, CY ← A – (HL + C)	x	x	x
	SUBC	A, #byte	2	4	–	A, CY ← A – byte – CY	x	x	x
		saddr, #byte	3	6	8	(saddr), CY ← (saddr) – byte – CY	x	x	x
		A, r <small>Note 3</small>	2	4	–	A, CY ← A – r – CY	x	x	x
		r, A	2	4	–	r, CY ← r – A – CY	x	x	x
		A, saddr	2	4	5	A, CY ← A – (saddr) – CY	x	x	x
		A, !addr16	3	8	9	A, CY ← A – (addr16) – CY	x	x	x
		A, [HL]	1	4	5	A, CY ← A – (HL) – CY	x	x	x
		A, [HL + byte]	2	8	9	A, CY ← A – (HL + byte) – CY	x	x	x
		A, [HL + B]	2	8	9	A, CY ← A – (HL + B) – CY	x	x	x
		A, [HL + C]	2	8	9	A, CY ← A – (HL + C) – CY	x	x	x
	AND	A, #byte	2	4	–	A ← A ∧ byte	x		
		saddr, #byte	3	6	8	(saddr) ← (saddr) ∧ byte	x		
		A, r <small>Note 3</small>	2	4	–	A ← A ∧ r	x		
		r, A	2	4	–	r ← r ∧ A	x		
		A, saddr	2	4	5	A ← A ∧ (saddr)	x		
		A, !addr16	3	8	9	A ← A ∧ (addr16)	x		
		A, [HL]	1	4	5	A ← A ∧ (HL)	x		
		A, [HL + byte]	2	8	9	A ← A ∧ (HL + byte)	x		
		A, [HL + B]	2	8	9	A ← A ∧ (HL + B)	x		
		A, [HL + C]	2	8	9	A ← A ∧ (HL + C)	x		

- Notes**
1. When the internal high-speed RAM area is accessed or for an instruction with no data access
 2. When an area except the internal high-speed RAM area is accessed
 3. Except “r = A”

- Remarks**
1. One instruction clock cycle is one cycle of the CPU clock (f_{CPU}) selected by the processor clock control register (PCC).
 2. This clock cycle applies to the internal ROM program.

Instruction Group	Mnemonic	Operands	Bytes	Clocks		Operation	Flag		
				Note 1	Note 2		Z	AC	CY
8-bit operation	OR	A, #byte	2	4	–	$A \leftarrow A \vee \text{byte}$	x		
		saddr, #byte	3	6	8	$(\text{saddr}) \leftarrow (\text{saddr}) \vee \text{byte}$	x		
		A, r <small>Note 3</small>	2	4	–	$A \leftarrow A \vee r$	x		
		r, A	2	4	–	$r \leftarrow r \vee A$	x		
		A, saddr	2	4	5	$A \leftarrow A \vee (\text{saddr})$	x		
		A, !addr16	3	8	9	$A \leftarrow A \vee (\text{addr16})$	x		
		A, [HL]	1	4	5	$A \leftarrow A \vee (\text{HL})$	x		
		A, [HL + byte]	2	8	9	$A \leftarrow A \vee (\text{HL} + \text{byte})$	x		
		A, [HL + B]	2	8	9	$A \leftarrow A \vee (\text{HL} + B)$	x		
	A, [HL + C]	2	8	9	$A \leftarrow A \vee (\text{HL} + C)$	x			
	XOR	A, #byte	2	4	–	$A \leftarrow A \nabla \text{byte}$	x		
		saddr, #byte	3	6	8	$(\text{saddr}) \leftarrow (\text{saddr}) \nabla \text{byte}$	x		
		A, r <small>Note 3</small>	2	4	–	$A \leftarrow A \nabla r$	x		
		r, A	2	4	–	$r \leftarrow r \nabla A$	x		
		A, saddr	2	4	5	$A \leftarrow A \nabla (\text{saddr})$	x		
		A, !addr16	3	8	9	$A \leftarrow A \nabla (\text{addr16})$	x		
		A, [HL]	1	4	5	$A \leftarrow A \nabla (\text{HL})$	x		
		A, [HL + byte]	2	8	9	$A \leftarrow A \nabla (\text{HL} + \text{byte})$	x		
		A, [HL + B]	2	8	9	$A \leftarrow A \nabla (\text{HL} + B)$	x		
	A, [HL + C]	2	8	9	$A \leftarrow A \nabla (\text{HL} + C)$	x			
	CMP	A, #byte	2	4	–	$A - \text{byte}$	x	x	x
		saddr, #byte	3	6	8	$(\text{saddr}) - \text{byte}$	x	x	x
		A, r <small>Note 3</small>	2	4	–	$A - r$	x	x	x
		r, A	2	4	–	$r - A$	x	x	x
		A, saddr	2	4	5	$A - (\text{saddr})$	x	x	x
		A, !addr16	3	8	9	$A - (\text{addr16})$	x	x	x
		A, [HL]	1	4	5	$A - (\text{HL})$	x	x	x
		A, [HL + byte]	2	8	9	$A - (\text{HL} + \text{byte})$	x	x	x
		A, [HL + B]	2	8	9	$A - (\text{HL} + B)$	x	x	x
	A, [HL + C]	2	8	9	$A - (\text{HL} + C)$	x	x	x	

- Notes**
1. When the internal high-speed RAM area is accessed or for an instruction with no data access
 2. When an area except the internal high-speed RAM area is accessed
 3. Except “r = A”

- Remarks**
1. One instruction clock cycle is one cycle of the CPU clock (f_{CPU}) selected by the processor clock control register (PCC).
 2. This clock cycle applies to the internal ROM program.

Instruction Group	Mnemonic	Operands	Bytes	Clocks		Operation	Flag		
				Note 1	Note 2		Z	AC	CY
16-bit operation	ADDW	AX, #word	3	6	–	AX, CY ← AX + word	×	×	×
	SUBW	AX, #word	3	6	–	AX, CY ← AX – word	×	×	×
	CMPW	AX, #word	3	6	–	AX – word	×	×	×
Multiply/divide	MULU	X	2	16	–	AX ← A × X			
	DIVUW	C	2	25	–	AX (Quotient), C (Remainder) ← AX ÷ C			
Increment/decrement	INC	r	1	2	–	r ← r + 1	×	×	
		saddr	2	4	6	(saddr) ← (saddr) + 1	×	×	
	DEC	r	1	2	–	r ← r – 1	×	×	
		saddr	2	4	6	(saddr) ← (saddr) – 1	×	×	
	INCW	rp	1	4	–	rp ← rp + 1			
	DECW	rp	1	4	–	rp ← rp – 1			
Rotate	ROR	A, 1	1	2	–	(CY, A7 ← A0, A _{m-1} ← A _m) × 1 time			×
	ROL	A, 1	1	2	–	(CY, A0 ← A7, A _{m+1} ← A _m) × 1 time			×
	RORC	A, 1	1	2	–	(CY ← A0, A7 ← CY, A _{m-1} ← A _m) × 1 time			×
	ROLC	A, 1	1	2	–	(CY ← A7, A0 ← CY, A _{m+1} ← A _m) × 1 time			×
	ROR4	[HL]	2	10	12	A ₃₋₀ ← (HL) ₃₋₀ , (HL) ₇₋₄ ← A ₃₋₀ , (HL) ₃₋₀ ← (HL) ₇₋₄			
	ROL4	[HL]	2	10	12	A ₃₋₀ ← (HL) ₇₋₄ , (HL) ₃₋₀ ← A ₃₋₀ , (HL) ₇₋₄ ← (HL) ₃₋₀			
BCD adjustment	ADJBA		2	4	–	Decimal Adjust Accumulator after Addition	×	×	×
	ADJBS		2	4	–	Decimal Adjust Accumulator after Subtract	×	×	×
Bit manipulate	MOV1	CY, saddr.bit	3	6	7	CY ← (saddr.bit)			×
		CY, sfr.bit	3	–	7	CY ← sfr.bit			×
		CY, A.bit	2	4	–	CY ← A.bit			×
		CY, PSW.bit	3	–	7	CY ← PSW.bit			×
		CY, [HL].bit	2	6	7	CY ← (HL).bit			×
		saddr.bit, CY	3	6	8	(saddr.bit) ← CY			
		sfr.bit, CY	3	–	8	sfr.bit ← CY			
		A.bit, CY	2	4	–	A.bit ← CY			
		PSW.bit, CY	3	–	8	PSW.bit ← CY			×
[HL].bit, CY	2	6	8	(HL).bit ← CY					

- Notes**
1. When the internal high-speed RAM area is accessed or for an instruction with no data access
 2. When an area except the internal high-speed RAM area is accessed

- Remarks**
1. One instruction clock cycle is one cycle of the CPU clock (f_{CPU}) selected by the processor clock control register (PCC).
 2. This clock cycle applies to the internal ROM program.

Instruction Group	Mnemonic	Operands	Bytes	Clocks		Operation	Flag			
				Note 1	Note 2		Z	AC	CY	
Bit manipulate	AND1	CY, saddr.bit	3	6	7	$CY \leftarrow CY \wedge (\text{saddr.bit})$			x	
		CY, sfr.bit	3	–	7	$CY \leftarrow CY \wedge \text{sfr.bit}$			x	
		CY, A.bit	2	4	–	$CY \leftarrow CY \wedge A.\text{bit}$			x	
		CY, PSW.bit	3	–	7	$CY \leftarrow CY \wedge \text{PSW.bit}$			x	
		CY, [HL].bit	2	6	7	$CY \leftarrow CY \wedge (\text{HL}).\text{bit}$			x	
	OR1	CY, saddr.bit	3	6	7	$CY \leftarrow CY \vee (\text{saddr.bit})$			x	
		CY, sfr.bit	3	–	7	$CY \leftarrow CY \vee \text{sfr.bit}$			x	
		CY, A.bit	2	4	–	$CY \leftarrow CY \vee A.\text{bit}$			x	
		CY, PSW.bit	3	–	7	$CY \leftarrow CY \vee \text{PSW.bit}$			x	
		CY, [HL].bit	2	6	7	$CY \leftarrow CY \vee (\text{HL}).\text{bit}$			x	
	XOR1	CY, saddr.bit	3	6	7	$CY \leftarrow CY \oplus (\text{saddr.bit})$			x	
		CY, sfr.bit	3	–	7	$CY \leftarrow CY \oplus \text{sfr.bit}$			x	
		CY, A.bit	2	4	–	$CY \leftarrow CY \oplus A.\text{bit}$			x	
		CY, PSW. bit	3	–	7	$CY \leftarrow CY \oplus \text{PSW.bit}$			x	
		CY, [HL].bit	2	6	7	$CY \leftarrow CY \oplus (\text{HL}).\text{bit}$			x	
	SET1	saddr.bit	2	4	6	$(\text{saddr.bit}) \leftarrow 1$				
		sfr.bit	3	–	8	$\text{sfr.bit} \leftarrow 1$				
		A.bit	2	4	–	$A.\text{bit} \leftarrow 1$				
		PSW.bit	2	–	6	$\text{PSW.bit} \leftarrow 1$		x	x	x
		[HL].bit	2	6	8	$(\text{HL}).\text{bit} \leftarrow 1$				
	CLR1	saddr.bit	2	4	6	$(\text{saddr.bit}) \leftarrow 0$				
		sfr.bit	3	–	8	$\text{sfr.bit} \leftarrow 0$				
		A.bit	2	4	–	$A.\text{bit} \leftarrow 0$				
		PSW.bit	2	–	6	$\text{PSW.bit} \leftarrow 0$		x	x	x
		[HL].bit	2	6	8	$(\text{HL}).\text{bit} \leftarrow 0$				
	SET1	CY	1	2	–	$CY \leftarrow 1$			1	
	CLR1	CY	1	2	–	$CY \leftarrow 0$			0	
	NOT1	CY	1	2	–	$CY \leftarrow \overline{CY}$			x	

- Notes**
1. When the internal high-speed RAM area is accessed or for an instruction with no data access
 2. When an area except the internal high-speed RAM area is accessed

- Remarks**
1. One instruction clock cycle is one cycle of the CPU clock (f_{CPU}) selected by the processor clock control register (PCC).
 2. This clock cycle applies to the internal ROM program.

Instruction Group	Mnemonic	Operands	Bytes	Clocks		Operation	Flag		
				Note 1	Note 2		Z	AC	CY
Call/return	CALL	!addr16	3	7	–	$(SP - 1) \leftarrow (PC + 3)_H, (SP - 2) \leftarrow (PC + 3)_L,$ $PC \leftarrow \text{addr16}, SP \leftarrow SP - 2$			
	CALLF	!addr11	2	5	–	$(SP - 1) \leftarrow (PC + 2)_H, (SP - 2) \leftarrow (PC + 2)_L,$ $PC_{15-11} \leftarrow 00001, PC_{10-0} \leftarrow \text{addr11},$ $SP \leftarrow SP - 2$			
	CALLT	[addr5]	1	6	–	$(SP - 1) \leftarrow (PC + 1)_H, (SP - 2) \leftarrow (PC + 1)_L,$ $PC_H \leftarrow (00000000, \text{addr5} + 1),$ $PC_L \leftarrow (00000000, \text{addr5}),$ $SP \leftarrow SP - 2$			
	BRK		1	6	–	$(SP - 1) \leftarrow PSW, (SP - 2) \leftarrow (PC + 1)_H,$ $(SP - 3) \leftarrow (PC + 1)_L, PC_H \leftarrow (003FH),$ $PC_L \leftarrow (003EH), SP \leftarrow SP - 3, IE \leftarrow 0$			
	RET		1	6	–	$PC_H \leftarrow (SP + 1), PC_L \leftarrow (SP),$ $SP \leftarrow SP + 2$			
	RETI		1	6	–	$PC_H \leftarrow (SP + 1), PC_L \leftarrow (SP),$ $PSW \leftarrow (SP + 2), SP \leftarrow SP + 3$	R	R	R
	RETB		1	6	–	$PC_H \leftarrow (SP + 1), PC_L \leftarrow (SP),$ $PSW \leftarrow (SP + 2), SP \leftarrow SP + 3$	R	R	R
Stack manipulate	PUSH	PSW	1	2	–	$(SP - 1) \leftarrow PSW, SP \leftarrow SP - 1$			
		rp	1	4	–	$(SP - 1) \leftarrow rp_H, (SP - 2) \leftarrow rp_L,$ $SP \leftarrow SP - 2$			
	POP	PSW	1	2	–	$PSW \leftarrow (SP), SP \leftarrow SP + 1$	R	R	R
		rp	1	4	–	$rp_H \leftarrow (SP + 1), rp_L \leftarrow (SP),$ $SP \leftarrow SP + 2$			
	MOVW	SP, #word	4	–	10	$SP \leftarrow \text{word}$			
		SP, AX	2	–	8	$SP \leftarrow AX$			
AX, SP		2	–	8	$AX \leftarrow SP$				
Unconditional branch	BR	!addr16	3	6	–	$PC \leftarrow \text{addr16}$			
		\$addr16	2	6	–	$PC \leftarrow PC + 2 + \text{jdisp8}$			
		AX	2	8	–	$PCH \leftarrow A, PCL \leftarrow X$			
Conditional branch	BC	\$addr16	2	6	–	$PC \leftarrow PC + 2 + \text{jdisp8}$ if $CY = 1$			
	BNC	\$addr16	2	6	–	$PC \leftarrow PC + 2 + \text{jdisp8}$ if $CY = 0$			
	BZ	\$addr16	2	6	–	$PC \leftarrow PC + 2 + \text{jdisp8}$ if $Z = 1$			
	BNZ	\$addr16	2	6	–	$PC \leftarrow PC + 2 + \text{jdisp8}$ if $Z = 0$			

- Notes**
1. When the internal high-speed RAM area is accessed or for an instruction with no data access
 2. When an area except the internal high-speed RAM area is accessed

- Remarks**
1. One instruction clock cycle is one cycle of the CPU clock (f_{CPU}) selected by the processor clock control register (PCC).
 2. This clock cycle applies to the internal ROM program.

Instruction Group	Mnemonic	Operands	Bytes	Clocks		Operation	Flag		
				Note 1	Note 2		Z	AC	CY
Conditional branch	BT	saddr.bit, \$addr16	3	8	9	PC ← PC + 3 + jdisp8 if (saddr.bit) = 1			
		sfr.bit, \$addr16	4	–	11	PC ← PC + 4 + jdisp8 if sfr.bit = 1			
		A.bit, \$addr16	3	8	–	PC ← PC + 3 + jdisp8 if A.bit = 1			
		PSW.bit, \$addr16	3	–	9	PC ← PC + 3 + jdisp8 if PSW.bit = 1			
		[HL].bit, \$addr16	3	10	11	PC ← PC + 3 + jdisp8 if (HL).bit = 1			
	BF	saddr.bit, \$addr16	4	10	11	PC ← PC + 4 + jdisp8 if (saddr.bit) = 0			
		sfr.bit, \$addr16	4	–	11	PC ← PC + 4 + jdisp8 if sfr.bit = 0			
		A.bit, \$addr16	3	8	–	PC ← PC + 3 + jdisp8 if A.bit = 0			
		PSW.bit, \$addr16	4	–	11	PC ← PC + 4 + jdisp8 if PSW.bit = 0			
		[HL].bit, \$addr16	3	10	11	PC ← PC + 3 + jdisp8 if (HL).bit = 0			
	BTCLR	saddr.bit, \$addr16	4	10	12	PC ← PC + 4 + jdisp8 if (saddr.bit) = 1 then reset (saddr.bit)			
		sfr.bit, \$addr16	4	–	12	PC ← PC + 4 + jdisp8 if sfr.bit = 1 then reset sfr.bit			
		A.bit, \$addr16	3	8	–	PC ← PC + 3 + jdisp8 if A.bit = 1 then reset A.bit			
		PSW.bit, \$addr16	4	–	12	PC ← PC + 4 + jdisp8 if PSW.bit = 1 then reset PSW.bit	×	×	×
		[HL].bit, \$addr16	3	10	12	PC ← PC + 3 + jdisp8 if (HL).bit = 1 then reset (HL).bit			
	DBNZ	B, \$addr16	2	6	–	B ← B – 1, then PC ← PC + 2 + jdisp8 if B ≠ 0			
		C, \$addr16	2	6	–	C ← C – 1, then PC ← PC + 2 + jdisp8 if C ≠ 0			
		saddr, \$addr16	3	8	10	(saddr) ← (saddr) – 1, then PC ← PC + 3 + jdisp8 if (saddr) ≠ 0			
CPU control	SEL	R _{Bn}	2	4	–	RBS1, 0 ← n			
	NOP		1	2	–	No Operation			
	EI		2	–	6	IE ← 1 (Enable Interrupt)			
	DI		2	–	6	IE ← 0 (Disable Interrupt)			
	HALT		2	6	–	Set HALT Mode			
	STOP		2	6	–	Set STOP Mode			

- Notes**
1. When the internal high-speed RAM area is accessed or for an instruction with no data access
 2. When an area except the internal high-speed RAM area is accessed

- Remarks**
1. One instruction clock cycle is one cycle of the CPU clock (f_{CPU}) selected by the processor clock control register (PCC).
 2. This clock cycle applies to the internal ROM program.

28.3 Instructions Listed by Addressing Type

(1) 8-bit instructions

MOV, XCH, ADD, ADDC, SUB, SUBC, AND, OR, XOR, CMP, MULU, DIVUW, INC, DEC, ROR, ROL, RORC, ROLC, ROR4, ROL4, PUSH, POP, DBNZ

Second Operand First Operand	#byte	A	r ^{Note}	sfr	saddr	laddr16	PSW	[DE]	[HL]	[HL + byte] [HL + B] [HL + C]	\$addr16	1	None
A	ADD ADDC SUB SUBC AND OR XOR CMP		MOV XCH ADD ADDC SUB SUBC AND OR XOR CMP	MOV XCH	MOV XCH ADD ADDC SUB SUBC AND OR XOR CMP	MOV XCH ADD ADDC SUB SUBC AND OR XOR CMP	MOV	MOV XCH	MOV XCH ADD ADDC SUB SUBC AND OR XOR CMP	MOV XCH ADD ADDC SUB SUBC AND OR XOR CMP		ROR ROL RORC ROLC	
r	MOV	MOV ADD ADDC SUB SUBC AND OR XOR CMP											INC DEC
B, C											DBNZ		
sfr	MOV	MOV											
saddr	MOV ADD ADDC SUB SUBC AND OR XOR CMP	MOV									DBNZ		INC DEC
laddr16		MOV											
PSW	MOV	MOV											PUSH POP
[DE]		MOV											
[HL]		MOV											ROR4 ROL4
[HL + byte] [HL + B] [HL + C]		MOV											
X													MULU
C													DIVUW

Note Except "r = A"

(2) 16-bit instructions

MOVW, XCHW, ADDW, SUBW, CMPW, PUSH, POP, INCW, DECW

Second Operand First Operand	#word	AX	rp ^{Note}	sfrp	saddrp	laddr16	SP	None
AX	ADDW SUBW CMPW		MOVW XCHW	MOVW	MOVW	MOVW	MOVW	
rp	MOVW	MOVW ^{Note}						INCW DECW PUSH POP
sfrp	MOVW	MOVW						
saddrp	MOVW	MOVW						
laddr16		MOVW						
SP	MOVW	MOVW						

Note Only when rp = BC, DE, HL

(3) Bit manipulation instructions

MOV1, AND1, OR1, XOR1, SET1, CLR1, NOT1, BT, BF, BTCLR

Second Operand First Operand	A.bit	sfr.bit	saddr.bit	PSW.bit	[HL].bit	CY	\$addr16	None
A.bit						MOV1	BT BF BTCLR	SET1 CLR1
sfr.bit						MOV1	BT BF BTCLR	SET1 CLR1
saddr.bit						MOV1	BT BF BTCLR	SET1 CLR1
PSW.bit						MOV1	BT BF BTCLR	SET1 CLR1
[HL].bit						MOV1	BT BF BTCLR	SET1 CLR1
CY	MOV1 AND1 OR1 XOR1	MOV1 AND1 OR1 XOR1	MOV1 AND1 OR1 XOR1	MOV1 AND1 OR1 XOR1	MOV1 AND1 OR1 XOR1			SET1 CLR1 NOT1

(4) Call instructions/branch instructions

CALL, CALLF, CALLT, BR, BC, BNC, BZ, BNZ, BT, BF, BTCLR, DBNZ

Second Operand First Operand	AX	!addr16	!addr11	[addr5]	\$addr16
Basic instruction	BR	CALL BR	CALLF	CALLT	BR BC BNC BZ BNZ
Compound instruction					BT BF BTCLR DBNZ

(5) Other instructions

ADJBA, ADJBS, BRK, RET, RETI, RETB, SEL, NOP, EI, DI, HALT, STOP

CHAPTER 29 ELECTRICAL SPECIFICATIONS (TARGET)

- Cautions**
1. These specifications show target values of (T) (S), and (R) products, which may change after device evaluation.
 2. The μ PD78F0537D has an on-chip debug function. Do not use this product for mass production because its reliability cannot be guaranteed after the on-chip debug function has been used, given the issue of the number of times the flash memory can be rewritten. NEC Electronics does not accept complaints concerning this product.

Absolute Maximum Ratings ($T_A = 25^\circ\text{C}$) (1/2)

Parameter	Symbol	Conditions	Ratings	Unit	
Supply voltage	V_{DD}		-0.5 to +6.5	V	
	EV_{DD}		-0.5 to +6.5	V	
	V_{SS}		-0.5 to +0.3	V	
	EV_{SS}		-0.5 to +0.3	V	
	AV_{REF}		-0.5 to $V_{DD} + 0.3^{\text{Note}}$	V	
	AV_{SS}		-0.5 to +0.3	V	
Input voltage	V_{I1}	P00 to P06, P10 to P17, P20 to P27, P30 to P33, P40 to P43, P50 to P53, P70 to P77, P120 to P124, P140, P141, X1, X2, XT1, XT2, RESET	-0.3 to $V_{DD} + 0.3^{\text{Note}}$	V	
	V_{I2}	P60 to P63 (N-ch open drain)	-0.3 to +6.5	V	
Output voltage	V_O		-0.3 to $V_{DD} + 0.3^{\text{Note}}$	V	
Analog input voltage	V_{AN}	ANI0 to ANI7	-0.3 to $AV_{REF} + 0.3^{\text{Note}}$ and -0.3 to $V_{DD} + 0.3^{\text{Note}}$	V	
Output current, high	I_{OH}	Per pin	-10	mA	
		Total of all pins -80 mA	P00 to P04, P40 to P43, P120, P130, P140, P141	-25	mA
			P05, P06, P10 to P17, P30 to P33, P50 to P53, P70 to P77	-55	mA

Note Must be 6.5 V or lower.

Caution Product quality may suffer if the absolute maximum rating is exceeded even momentarily for any parameter. That is, the absolute maximum ratings are rated values at which the product is on the verge of suffering physical damage, and therefore the product must be used under conditions that ensure that the absolute maximum ratings are not exceeded.

Remark Unless specified otherwise, the characteristics of alternate-function pins are the same as those of port pins.

Absolute Maximum Ratings (T_A = 25°C) (2/2)

Parameter	Symbol	Conditions	Ratings	Unit	
Output current, low	I _{OL}	Per pin	30	mA	
		Total of all pins 200 mA	P00 to P04, P40 to P43, P120, P130, P140, P141	60	mA
			P05, P06, P10 to P17, P30 to P33, P50 to P53, P60 to P63, P70 to P77	140	mA
Operating ambient temperature	T _A	In normal operation mode	-40 to +85	°C	
		In flash memory programming mode			
Storage temperature	T _{stg}		-40 to +150	°C	

Caution Product quality may suffer if the absolute maximum rating is exceeded even momentarily for any parameter. That is, the absolute maximum ratings are rated values at which the product is on the verge of suffering physical damage, and therefore the product must be used under conditions that ensure that the absolute maximum ratings are not exceeded.

Remark Unless specified otherwise, the characteristics of alternate-function pins are the same as those of port pins.

X1 Oscillator Characteristics

($T_A = -40$ to $+85^\circ\text{C}$, $1.8\text{ V} \leq V_{DD} = EV_{DD} \leq 5.5\text{ V}$, $V_{SS} = EV_{SS} = AV_{SS} = 0\text{ V}$)

Internal Oscillator Characteristics

($T_A = -40$ to $+85^\circ\text{C}$, $1.8\text{ V} \leq V_{DD} = EV_{DD} \leq 5.5\text{ V}$, $V_{SS} = EV_{SS} = AV_{SS} = 0\text{ V}$)

Resonator	Parameter	Conditions	MIN.	TYP.	MAX.	Unit
8 MHz internal oscillator	Internal high-speed oscillation clock frequency (f_{RH}) ^{Note 1}	$2.7\text{ V} \leq V_{DD} \leq 5.5\text{ V}$	7.6 ^{Note 2}	8.0 ^{Note 2}	8.4 ^{Note 2}	MHz
		$1.8\text{ V} \leq V_{DD} < 2.7\text{ V}$	7.6 ^{Note 2}	8.0 ^{Note 2}	10.4 ^{Note 2}	MHz
240 kHz internal oscillator	Internal low-speed oscillation clock frequency (f_{RL})	$2.7\text{ V} \leq V_{DD} \leq 5.5\text{ V}$	216	240	264	kHz
		$1.8\text{ V} \leq V_{DD} < 2.7\text{ V}$	120	240	264	kHz

- Notes**
1. Indicates only oscillator characteristics. Refer to **AC Characteristics** for instruction execution time.
 2. This is the frequency when RSTS (bit 7 of the internal oscillation mode register (RCM)) = 1. It is 5.6 MHz (TYP.) when RSTS = 0.

XT1 Oscillator Characteristics

($T_A = -40$ to $+85^\circ\text{C}$, $1.8\text{ V} \leq V_{DD} = EV_{DD} \leq 5.5\text{ V}$, $V_{SS} = EV_{SS} = AV_{SS} = 0\text{ V}$)

Resonator	Recommended Circuit	Parameter	Conditions	MIN.	TYP.	MAX.	Unit
Crystal resonator		XT1 clock oscillation frequency (f_{XT1}) ^{Note}		32	32.768	35	kHz

Note Indicates only oscillator characteristics. Refer to **AC Characteristics** for instruction execution time.

Cautions

1. When using the XT1 oscillator, wire as follows in the area enclosed by the broken lines in the above figure to avoid an adverse effect from wiring capacitance.

- Keep the wiring length as short as possible.
- Do not cross the wiring with the other signal lines.
- Do not route the wiring near a signal line through which a high fluctuating current flows.
- Always make the ground point of the oscillator capacitor the same potential as Vss.
- Do not ground the capacitor to a ground pattern through which a high current flows.
- Do not fetch signals from the oscillator.

2. The XT1 oscillator is designed as a low-amplitude circuit for reducing power consumption, and is more prone to malfunction due to noise than the X1 oscillator. Particular care is therefore required with the wiring method when the XT1 clock is used.

Remark For the resonator selection and oscillator constant, customers are requested to either evaluate the oscillation themselves or apply to the resonator manufacturer for evaluation.

DC Characteristics (1/4)

($T_A = -40$ to $+85^\circ\text{C}$, $1.8\text{ V} \leq V_{DD} = EV_{DD} \leq 5.5\text{ V}$, $AV_{REF} \leq V_{DD}$, $V_{SS} = EV_{SS} = AV_{SS} = 0\text{ V}$)

Parameter	Symbol	Conditions	MIN.	TYP.	MAX.	Unit	
Output current, high ^{Note 1}	IOH1	Per pin for P00 to P06, P10 to P17, P30 to P33, P40 to P43, P50 to P53, P70 to P77, P120, P130, P140, P141	$4.0\text{ V} \leq V_{DD} \leq 5.5\text{ V}$			-3.0	mA
			$2.7\text{ V} \leq V_{DD} < 4.0\text{ V}$			-2.5	mA
			$1.8\text{ V} \leq V_{DD} < 2.7\text{ V}$			-1.0	mA
		Total of P00 to P04, P40 to P43, P120, P130, P140, P141 ^{Note 3}	$4.0\text{ V} \leq V_{DD} \leq 5.5\text{ V}$			-20.0	mA
			$2.7\text{ V} \leq V_{DD} < 4.0\text{ V}$			-10.0	mA
			$1.8\text{ V} \leq V_{DD} < 2.7\text{ V}$			-5.0	mA
		Total of P05, P06, P10 to P17, P30 to P33, P50 to P53, P70 to P77 ^{Note 3}	$4.0\text{ V} \leq V_{DD} \leq 5.5\text{ V}$			-30.0	mA
			$2.7\text{ V} \leq V_{DD} < 4.0\text{ V}$			-19.0	mA
			$1.8\text{ V} \leq V_{DD} < 2.7\text{ V}$			-10.0	mA
		Total ^{Note 3} of all pins	$4.0\text{ V} \leq V_{DD} \leq 5.5\text{ V}$			-50.0	mA
			$2.7\text{ V} \leq V_{DD} < 4.0\text{ V}$			-29.0	mA
			$1.8\text{ V} \leq V_{DD} < 2.7\text{ V}$			-15.0	mA
	IOH2	Per pin for P20 to P27	$AV_{REF} = V_{DD}$			-0.1	mA
		Per pin for P121 to P124				-0.1	mA
Output current, low ^{Note 2}	IOL1	Per pin for P00 to P06, P10 to P17, P30 to P33, P40 to P43, P50 to P53, P70 to P77, P120, P130, P140, P141	$4.0\text{ V} \leq V_{DD} \leq 5.5\text{ V}$			8.5	mA
			$2.7\text{ V} \leq V_{DD} < 4.0\text{ V}$			5.0	mA
			$1.8\text{ V} \leq V_{DD} < 2.7\text{ V}$			2.0	mA
		Per pin for P60 to P63	$4.0\text{ V} \leq V_{DD} \leq 5.5\text{ V}$			15.0	mA
			$2.7\text{ V} \leq V_{DD} < 4.0\text{ V}$			5.0	mA
			$1.8\text{ V} \leq V_{DD} < 2.7\text{ V}$			2.0	mA
		Total of P00 to P04, P40 to P43, P120, P130, P140, P141 ^{Note 3}	$4.0\text{ V} \leq V_{DD} \leq 5.5\text{ V}$			20.0	mA
			$2.7\text{ V} \leq V_{DD} < 4.0\text{ V}$			15.0	mA
			$1.8\text{ V} \leq V_{DD} < 2.7\text{ V}$			9.0	mA
		Total of P05, P06, P10 to P17, P30 to P33, P50 to P53, P60 to P63, P70 to P77 ^{Note 3}	$4.0\text{ V} \leq V_{DD} \leq 5.5\text{ V}$			45.0	mA
			$2.7\text{ V} \leq V_{DD} < 4.0\text{ V}$			35.0	mA
			$1.8\text{ V} \leq V_{DD} < 2.7\text{ V}$			20.0	mA
	Total of all pins ^{Note 3}	$4.0\text{ V} \leq V_{DD} \leq 5.5\text{ V}$			65.0	mA	
		$2.7\text{ V} \leq V_{DD} < 4.0\text{ V}$			50.0	mA	
		$1.8\text{ V} \leq V_{DD} < 2.7\text{ V}$			29.0	mA	
	IOL2	Per pin for P20 to P27	$AV_{REF} = V_{DD}$			0.4	mA
		Per pin for P121 to P124				0.4	mA

Notes 1. Value of current at which the device operation is guaranteed even if the current flows from V_{DD} to an output pin.

2. Value of current at which the device operation is guaranteed even if the current flows from an output pin to GND.

3. Specification under conditions where the duty factor is 70% (time for which current is output is $0.7 \times t$ and time for which current is not output is $0.3 \times t$, where t is a specific time). The total output current of the pins at a duty factor of other than 70% can be calculated by the following expression.

- Where the duty factor of I_{OH} is $n\%$: Total output current of pins = $(I_{OH} \times 0.7)/(n \times 0.01)$

<Example> Where the duty factor is 50%, $I_{OH} = 20.0\text{ mA}$

$$\text{Total output current of pins} = (20.0 \times 0.7)/(50 \times 0.01) = 28.0\text{ mA}$$

However, the current that is allowed to flow into one pin does not vary depending on the duty factor. A current higher than the absolute maximum rating must not flow into one pin.

Remark Unless specified otherwise, the characteristics of alternate-function pins are the same as those of port pins.

DC Characteristics (2/4)

($T_A = -40$ to $+85^\circ\text{C}$, $1.8\text{ V} \leq V_{DD} = EV_{DD} \leq 5.5\text{ V}$, $AV_{REF} \leq V_{DD}$, $V_{SS} = EV_{SS} = AV_{SS} = 0\text{ V}$)

Parameter	Symbol	Conditions	MIN.	TYP.	MAX.	Unit
Input voltage, high ($\mu\text{PD78F0534}$, 78F0535 , 78F0536 , 78F0537 , 78F0537D)	V_{IH1}	P02, P12, P13, P15, P40 to P43, P50 to P53, P63, P121 to P124	$0.7V_{DD}$		V_{DD}	V
	V_{IH2}	P00, P01, P03 to P06, P10, P11, P14, P16, P17, P30 to P33, P60 to P62, P70 to P77, P120, P140, P141, RESET	$0.8V_{DD}$		V_{DD}	V
	V_{IH3}	P20 to P27 $AV_{REF} = V_{DD}$	$0.7AV_{REF}$		AV_{REF}	V
	V_{IH1}	P02 to P06, P12, P13, P15, P40 to P43, P50 to P53, P63, P121 to P124	$0.7V_{DD}$		V_{DD}	V
	V_{IH2}	P00, P01, P10, P11, P14, P16, P17, P30 to P33,				

DC Characteristics (3/4)

(TA = -40 to +85°C, 1.8 V ≤ VDD = EVDD ≤ 5.5 V, AVREF ≤ VDD, VSS = EVSS = AVSS = 0 V)

Parameter	Symbol	Conditions	MIN.	TYP.	MAX.	Unit	
Output voltage, low	VOL1	P00 to P06, P10 to P17, P30 to P33, P40 to P43, P50 to P53, P70 to P77, P120, P130, P140, P141	4.0 V ≤ VDD ≤ 5.5 V, IOL1 = 8.5 mA			0.7	V
			2.7 V ≤ VDD < 4.0 V, IOL1 = 5.0 mA			0.7	V
			1.8 V ≤ VDD < 2.7 V, IOL1 = 2.0 mA			0.5	V
			1.8 V ≤ VDD < 2.7 V, IOL1 = 0.5 mA			0.4	
	VOL2	P20 to P27 P121 to P124	AVREF = VDD, IOL2 = 0.4 mA			0.4	V
			IOL2 = 0.4 mA			0.4	V
	VOL3	P60 to P63	4.0 V ≤ VDD ≤ 5.5 V, IOL3 = 15.0 mA			2.0	V
			4.0 V ≤ VDD ≤ 5.5 V, IOL3 = 5.0 mA			0.4	V
			2.7 V ≤ VDD < 4.0 V, IOL1 = 3.0 mA			0.4	V
			1.8 V ≤ VDD < 2.7 V, IOL1 = 2.0 mA			0.4	V
Input leakage current, high	ILIH1	P00 to P06, P10 to P17, P30 to P33, P40 to P43, P50 to P53, P60 to P63, P70 to P77, P120, P130, P140, P141	VI = VDD			1	μA
			VI = AVREF = VDD			1	μA
	ILIH3	P121 to 124 X1, X2, XT1, XT2	VI = VDD	I/O port mode		1	μA
			VI = VDD	OSC mode		20	μA
Input leakage current, low	ILIL1	P00 to P06, P10 to P17, P30 to P33, P40 to P43, P50 to P53, P60 to P63, P70 to P77, P120, P130, P140, P141	VI = VSS			-1	μA
			VI = VSS, AVREF = VDD			-1	μA
	ILIL3	P121 to 124 X1, X2, XT1, XT2	VI = VSS	I/O port mode		-1	μA
			VI = VSS	OSC mode		-20	μA
Pull-up resistor	RU	VI = VDD		10	20	100	kΩ
FLMD0 supply voltage	VIL	In normal operation mode		0		0.2VDD	V
	VIH	In self-programming mode		0.8VDD		VDD	V

Remark Unless specified otherwise, the characteristics of alternate-function pins are the same as those of port pins.

DC Characteristics (4/4)

 (T_A = -40 to +85°C, 1.8 V ≤ V_{DD} = EV_{DD} ≤ 5.5 V, AV_{REF} ≤ V_{DD}, V_{SS} = EV_{SS} = AV_{SS} = 0 V)

Parameter	Symbol	Conditions	MIN.	TYP.	MAX.	Unit	
Supply current	I _{DD1} ^{Note 1}	Operating mode	f _{XH} = 20 MHz ^{Note 2} , V _{DD} = 5.0 V		4.7	5.8	mA
			f _{XH} = 10 MHz ^{Notes 2, 3} , V _{DD} = 5.0 V		2.5	3.5	mA
			f _{XH} = 10 MHz ^{Notes 2, 3} , V _{DD} = 3.0 V		2.1	3.1	mA
			f _{XH} = 5 MHz ^{Notes 2, 3} , V _{DD} = 3.0 V		1.5	2.2	mA
			f _{XH} = 5 MHz ^{Notes 2, 3} , V _{DD} = 2.0 V		1.2	1.8	mA
			f _{RH} = 8 MHz, V _{DD} = 5.0 V		1.9	2.7	mA
			f _{SUB} = 32.768 kHz ^{Notes 2, 4} , V _{DD} = 5.0 V		17	30	μA
	I _{DD2} ^{Note 5}	HALT mode	f _{XH} = 20 MHz ^{Note 2} , V _{DD} = 5.0 V		2.2	2.6	mA
			f _{XH} = 10 MHz ^{Notes 2, 3} , V _{DD} = 5.0 V		1.0	1.2	mA
			f _{XH} = 5 MHz ^{Notes 2, 3} , V _{DD} = 3.0 V		0.55	0.65	mA
			f _{RH} = 8 MHz, V _{DD} = 5.0 V		0.6	0.65	mA
			f _{SUB} = 32.768 kHz ^{Notes 2, 4} , V _{DD} = 5.0 V		3.5	20	μA
I _{DD3} ^{Note 5}	STOP mode	V _{DD} = 5.0 V		1	20	μA	
A/D converter operating current	I _{ADC} ^{Note 6}	During conversion at maximum speed 2.3 V ≤ AV _{REF} ≤ V _{DD}		0.86	1.9	mA	
Watchdog timer operating current	I _{WD1} ^{Note 7}	During 240 kHz internal low-speed oscillation clock operation		5	10	μA	
LVI operating current	I _{LVI} ^{Note 8}			9	35	μA	

- Notes**
- Total current flowing into the internal power supply (V_{DD}), including the peripheral operation current (however, the current flowing into the pull-up resistors of the port, and A/D converter is not included).
 - Square-wave input
 - When AMPH (bit 0 of clock operation mode select register (OSCCTL)) = 0.
 - When main system clock is stopped
 - Total current flowing into the internal power supply (V_{DD}), including the peripheral operating current (however, the current flowing into the pull-up resistor of the port, A/D converter, watchdog timer, and LVI circuit is not included)
 - Current flowing only to the A/D converter. The current value of the 78K0/KE2 is the sum of I_{DD1} or I_{DD2} and I_{ADC} when the A/D converter operates in an operation mode or the HALT mode.
 - Current flowing only to the watchdog timer. The current value of the 78K0/KE2 is the sum of I_{DD2} or I_{DD3} and I_{WD1} when the watchdog timer operates in the HALT or STOP mode.
 - Current flowing only to the LVI circuit. The current value of the 78K0/KE2 is the sum of I_{DD2} or I_{DD3} and I_{LVI} when the LVI circuit operates in the HALT or STOP mode.

- Remarks**
- f_{XH}: High-speed system clock frequency (X1 clock oscillation frequency or external main system clock frequency)
 - f_{RH}: Internal high-speed oscillation clock frequency
 - f_{SUB}: Subsystem clock frequency (XT1 clock oscillation frequency or external subsystem clock frequency)

AC Characteristics

(1) Basic operation

 $(T_A = -40 \text{ to } +85^\circ\text{C}, 1.8 \text{ V} \leq V_{DD} = EV_{DD} \leq 5.5 \text{ V}, AV_{REF} \leq V_{DD}, V_{SS} = EV_{SS} = AV_{SS} = 0 \text{ V})$

Parameter	Symbol	Conditions	MIN.	TYP.	MAX.	Unit	
Instruction cycle (minimum instruction execution time)	T_{CY}	Main system clock (f_{XP}) operation	$4.0 \text{ V} \leq V_{DD} \leq 5.5 \text{ V}$	0.1		32	μs
			$2.7 \text{ V} \leq V_{DD} < 4.0 \text{ V}$	0.2		32	μs
			$1.8 \text{ V} \leq V_{DD} < 2.7 \text{ V}$	0.4 ^{Note 1}		32	μs
		Subsystem clock (f_{SUB}) operation		114	122	125	μs
External main system clock frequency	f_{EXCLK}	$4.0 \text{ V} \leq V_{DD} \leq 5.5 \text{ V}$	1.0		20.0	MHz	
		$2.7 \text{ V} \leq V_{DD} < 4.0 \text{ V}$	1.0		10.0	MHz	
		$1.8 \text{ V} \leq V_{DD} < 2.7 \text{ V}$	1.0		5.0	MHz	
External main system clock input high-level width, low-level width	t_{EXCLKH} , t_{EXCLKL}		$(1/f_{EXCLK} \times 1/2) - 1$			ns	
External subsystem clock frequency	f_{EXCLKS}		32	32.768	35	kHz	
External subsystem clock input high-level width, low-level width	$t_{EXCLKSH}$, $t_{EXCLKSL}$		$(1/f_{EXCLKS} \times 1/2) - 5$			ns	
TI000, TI010, TI001 ^{Note 2} , TI011 ^{Note 2} input high-level width, low-level width	t_{TIH0} , t_{TIL0}	$4.0 \text{ V} \leq V_{DD} \leq 5.5 \text{ V}$	$2/f_{sam} + 0.1$ ^{Note 3}			μs	
		$2.7 \text{ V} \leq V_{DD} < 4.0 \text{ V}$	$2/f_{sam} + 0.2$ ^{Note 3}			μs	
TI50, TI51 input frequency	f_{TI5}	$4.0 \text{ V} \leq V_{DD} \leq 5.5 \text{ V}$			10	MHz	
		$2.7 \text{ V} \leq V_{DD} < 4.0 \text{ V}$			10	MHz	
		$1.8 \text{ V} \leq V_{DD} < 2.7 \text{ V}$			5	MHz	
TI50, TI51 input high-level width, low-level width	t_{TIH5} , t_{TIL5}	$4.0 \text{ V} \leq V_{DD} \leq 5.5 \text{ V}$	50			ns	
		$2.7 \text{ V} \leq V_{DD} < 4.0 \text{ V}$	50			ns	
		$1.8 \text{ V} \leq V_{DD} < 2.7 \text{ V}$	100			ns	
Interrupt input high-level width, low-level width	t_{INTH} , t_{INTL}		1			μs	
Key interrupt input low-level width	t_{KR}		250			ns	
RESET low-level width	t_{RSL}		10			μs	

- Notes**
- 0.38 μs when operating with the 8 MHz internal oscillator.
 - $\mu\text{PD78F0534}$, 78F0535, 78F0536, 78F0537, and 78F0537D only.
 - Selection of $f_{sam} = f_{PRS}$, $f_{PRS}/4$, $f_{PRS}/256$, or f_{PRS} , $f_{PRS}/16$, $f_{PRS}/64$ is possible using bits 0 and 1 (PRM000, PRM001 or PRM010, PRM011) of prescaler mode registers 00 and 01 (PRM00, PRM01). Note that when selecting the TI000 or TI001 valid edge as the count clock, $f_{sam} = f_{PRS}$.

T_{CY} vs. V_{DD} (Main System Clock Operation)

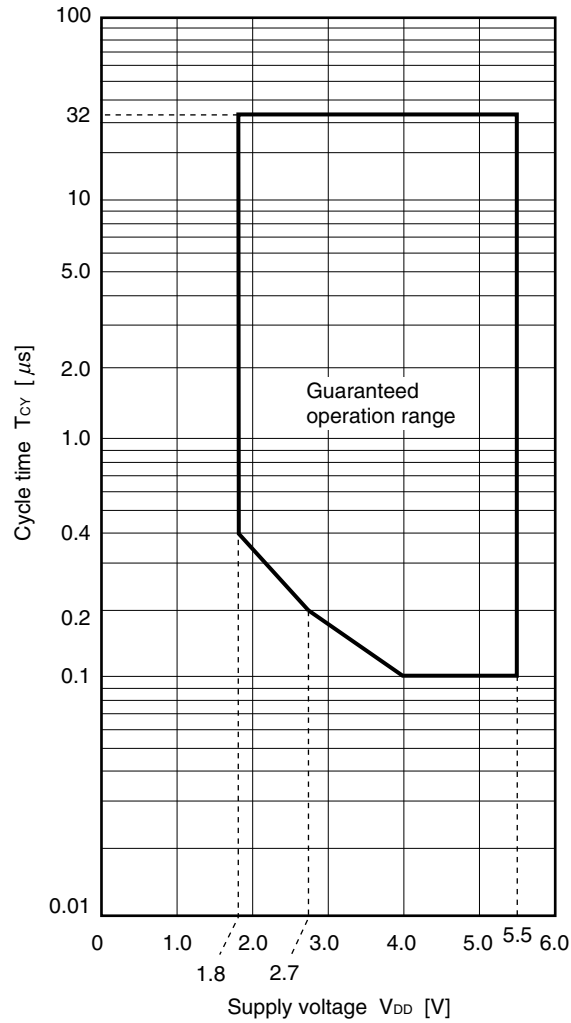

AC Timing Test Points (Excluding External Main System Clock and External Subsystem Clock)

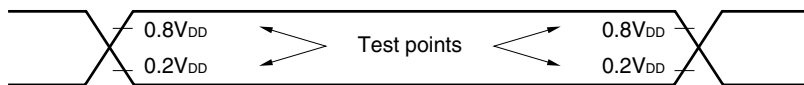

External Main System Clock Timing, External Subsystem Clock Timing

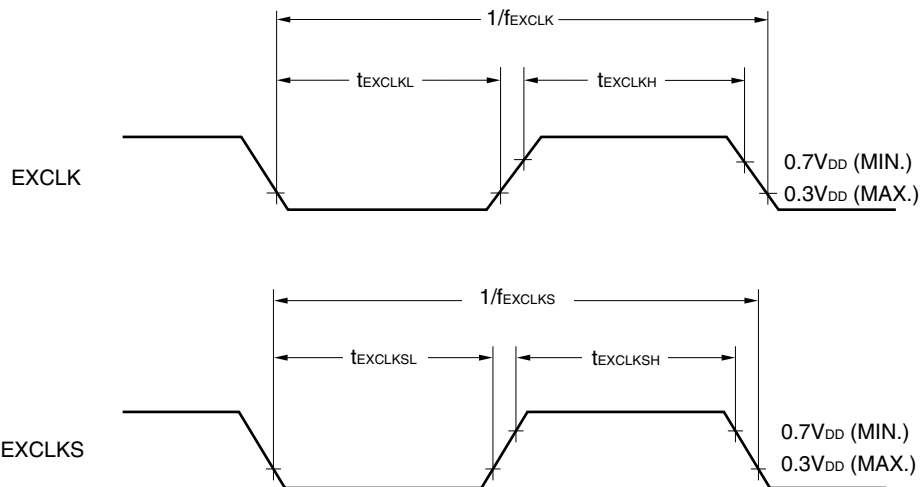

TI Timing

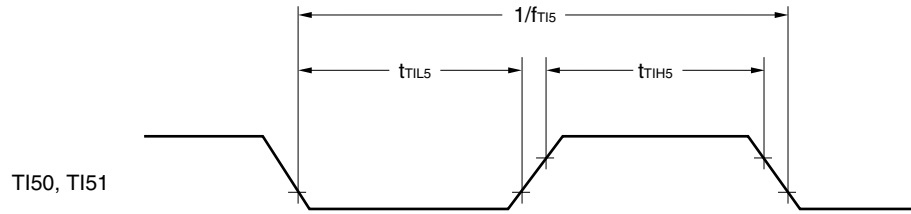

Interrupt Request Input Timing

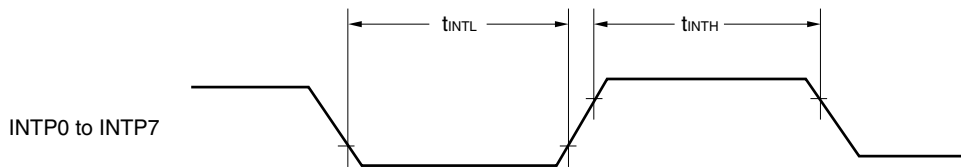

Key Interrupt Input Timing

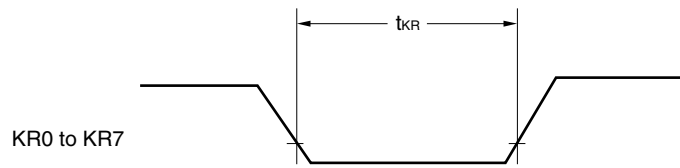

RESET Input Timing

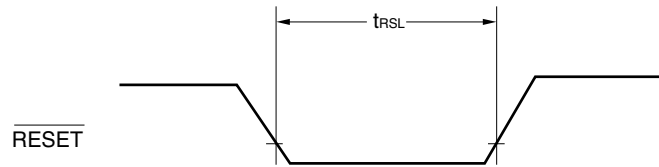

Note μ PD78F0534, 78F0535, 78F0536, 78F0537, and 78F0537D only.

(2) Serial interface
 $(T_A = -40 \text{ to } +85^\circ\text{C}, 1.8 \text{ V} \leq V_{DD} = EV_{DD} \leq 5.5 \text{ V}, AV_{REF} \leq V_{DD}, V_{SS} = EV_{SS} = AV_{SS} = 0 \text{ V})$
(a) UART6 (dedicated baud rate generator output)

Parameter	Symbol	Conditions	MIN.	TYP.	MAX.	Unit
Transfer rate					312.5	kbps

(b) UART0 (dedicated baud rate generator output)

Parameter	Symbol	Conditions	MIN.	TYP.	MAX.	Unit
Transfer rate					312.5	kbps

(c) IIC0

Parameter	Symbol	Standard Mode		High-Speed Mode		Unit
		MIN.	MAX.	MIN.	MAX.	
SCL0 clock frequency	f _{SCL}	0	100	0	400	kHz
Setup time of start/restart condition ^{Note 1}	t _{SU:STA}	4.8	–	0.7	–	μs
Hold time	t _{HD:STA}	4.1	–	0.7	–	μs
Hold time when SCL0 = “L”	t _{LOW}	5.0	–	1.25	–	μs
Hold time when SCL0 = “H”	t _{HIGH}	5.0	–	1.25	–	μs
Data setup time (reception)	t _{SU:DAT}	0	–	0	–	μs
Data hold time (transmission) ^{Note 2}	t _{HD:DAT}	0.47	4.0	0.23	1.00	μs

Notes 1. The first clock pulse is generated after this period when the start/restart condition is detected.

2. The maximum value (MAX.) of t_{HD:DAT} is during normal transfer and a wait state is inserted in the $\overline{\text{ACK}}$ (acknowledge) timing.

(d) CSI1n (master mode, $\overline{\text{SCK1n}}$... internal clock output)

Parameter	Symbol	Conditions	MIN.	TYP.	MAX.	Unit
$\overline{\text{SCK1n}}$ cycle time	t _{KCY1}	4.0 V ≤ V _{DD} ≤ 5.5 V	100			ns
		2.7 V ≤ V _{DD} < 4.0 V	200			ns
		1.8 V ≤ V _{DD} < 2.7 V	400			ns
$\overline{\text{SCK1n}}$ high-/low-level width	t _{KH1} , t _{KL1}		t _{KCY1} /2 – 10 ^{Note 1}			ns
SI1n setup time (to $\overline{\text{SCK1n}}\uparrow$)	t _{SIK1}		30			ns
SI1n hold time (from $\overline{\text{SCK1n}}\uparrow$)	t _{KSH1}		30			ns
Delay time from $\overline{\text{SCK1n}}\downarrow$ to SO1n output	t _{KSO1}	C = 50 pF ^{Note 2}			40	ns

Notes 1. This value is when high-speed system clock (f_{XH}) is used.

2. C is the load capacitance of the $\overline{\text{SCK1n}}$ and SO1n output lines.

Remark n = 0: μPD78F0531, 78F0532, 78F0533

n = 0, 1: μPD78F0534, 78F0535, 78F0536, 78F0537, 78F0537D

(e) CSI1n (slave mode, $\overline{\text{SCK1n}}$... external clock input)

Parameter	Symbol	Conditions	MIN.	TYP.	MAX.	Unit
$\overline{\text{SCK1n}}$ cycle time	t_{KCY2}		400			ns
$\overline{\text{SCK1n}}$ high-/low-level width	$t_{\text{KH2}},$ t_{KL2}		$t_{\text{KCY2}}/2$			ns
SI1n setup time (to $\overline{\text{SCK1n}}\uparrow$)	t_{SIK2}		80			ns
SI1n hold time (from $\overline{\text{SCK1n}}\uparrow$)	t_{SIL2}		50			ns
Delay time from $\overline{\text{SCK1n}}\downarrow$ to SO1n output	t_{KSO2}	$C = 50 \text{ pF}^{\text{Note}}$			120	ns

Note C is the load capacitance of the SO1n output line.

Remark n = 0: $\mu\text{PD78F0531}, 78\text{F0532}, 78\text{F0533}$

n = 0, 1: $\mu\text{PD78F0534}, 78\text{F0535}, 78\text{F0536}, 78\text{F0537}, 78\text{F0537D}$

Serial Transfer Timing

IIC0:

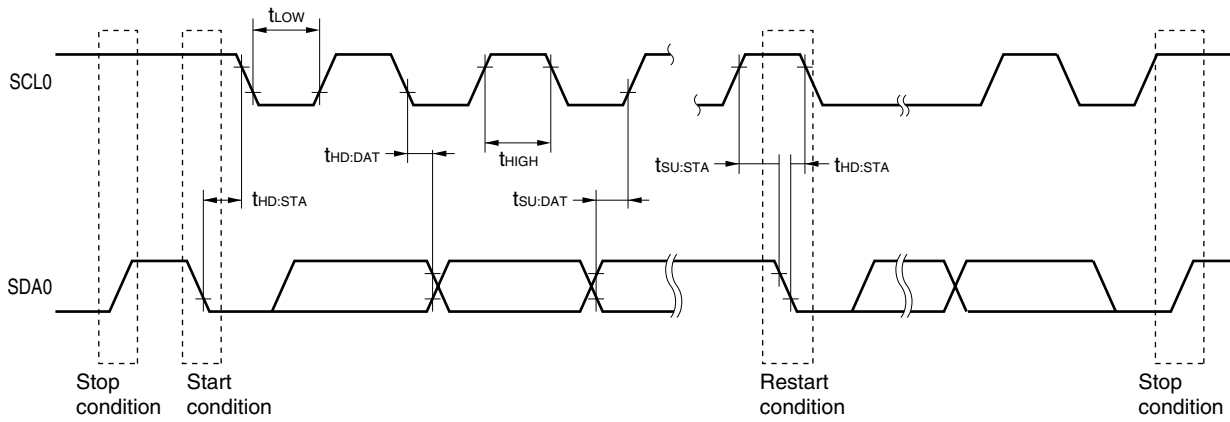

CSI1n:

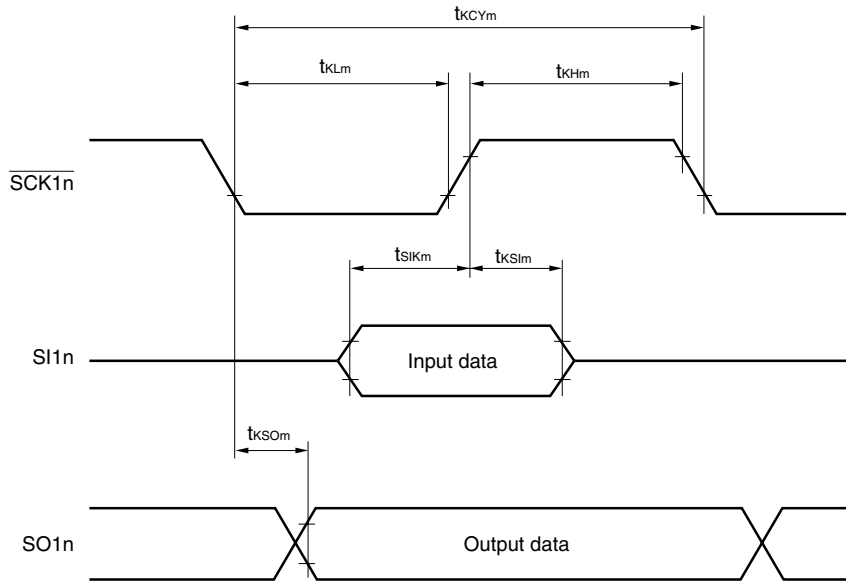

Remark m = 1, 2

n = 0: μ PD78F0531, 78F0532, 78F0533

n = 0, 1: μ PD78F0534, 78F0535, 78F0536, 78F0537, 78F0537D

A/D Converter Characteristics

 ($T_A = -40$ to $+85^\circ\text{C}$, $1.8\text{ V} \leq V_{DD} = EV_{DD} \leq 5.5\text{ V}$, $2.3\text{ V} \leq AV_{REF} \leq V_{DD}$, $V_{SS} = EV_{SS} = AV_{SS} = 0\text{ V}$)

Parameter	Symbol	Conditions	MIN.	TYP.	MAX.	Unit
Resolution	R_{ES}				10	bit
Overall error ^{Notes 1, 2}	A_{INL}	$4.0\text{ V} \leq AV_{REF} \leq 5.5\text{ V}$			± 0.4	%FSR
		$2.7\text{ V} \leq AV_{REF} < 4.0\text{ V}$			± 0.6	%FSR
		$2.3\text{ V} \leq AV_{REF} < 2.7\text{ V}$			± 1.2	%FSR
Conversion time	t_{CONV}	$4.0\text{ V} \leq AV_{REF} \leq 5.5\text{ V}$	6.1		36.7	μs
		$2.7\text{ V} \leq AV_{REF} < 4.0\text{ V}$	12.2		36.7	μs
		$2.3\text{ V} \leq AV_{REF} < 2.7\text{ V}$	27		66.6	μs
Zero-scale error ^{Notes 1, 2}	E_{ZS}	$4.0\text{ V} \leq AV_{REF} \leq 5.5\text{ V}$			± 0.4	%FSR
		$2.7\text{ V} \leq AV_{REF} < 4.0\text{ V}$			± 0.6	%FSR
		$2.3\text{ V} \leq AV_{REF} < 2.7\text{ V}$			± 0.6	%FSR
Full-scale error ^{Notes 1, 2}	E_{FS}	$4.0\text{ V} \leq AV_{REF} \leq 5.5\text{ V}$			± 0.4	%FSR
		$2.7\text{ V} \leq AV_{REF} < 4.0\text{ V}$			± 0.6	%FSR
		$2.3\text{ V} \leq AV_{REF} < 2.7\text{ V}$			± 0.6	%FSR
Integral non-linearity error ^{Note 1}	I_{LE}	$4.0\text{ V} \leq AV_{REF} \leq 5.5\text{ V}$			± 2.5	LSB
		$2.7\text{ V} \leq AV_{REF} < 4.0\text{ V}$			± 4.5	LSB
		$2.3\text{ V} \leq AV_{REF} < 2.7\text{ V}$			± 6.5	LSB
Differential non-linearity error ^{Note 1}	D_{LE}	$4.0\text{ V} \leq AV_{REF} \leq 5.5\text{ V}$			± 1.5	LSB
		$2.7\text{ V} \leq AV_{REF} < 4.0\text{ V}$			± 2.0	LSB
		$2.3\text{ V} \leq AV_{REF} < 2.7\text{ V}$			± 2.0	%FSR
Analog input voltage	V_{AIN}		AV_{SS}		AV_{REF}	V

Notes 1. Excludes quantization error ($\pm 1/2$ LSB).

2. This value is indicated as a ratio (%FSR) to the full-scale value.

1.59 V POC Circuit Characteristics ($T_A = -40$ to $+85^\circ\text{C}$, $V_{SS} = EV_{SS} = 0\text{ V}$)

Parameter	Symbol	Conditions	MIN.	TYP.	MAX.	Unit
Detection voltage	V_{POC}		1.44	1.59	1.74	V
Power voltage rise inclination	t_{PTH}	$V_{DD}: 0\text{ V} \rightarrow$ change inclination of V_{POC}			0.5	V/ms
Minimum pulse width	t_{PW}		200			μs

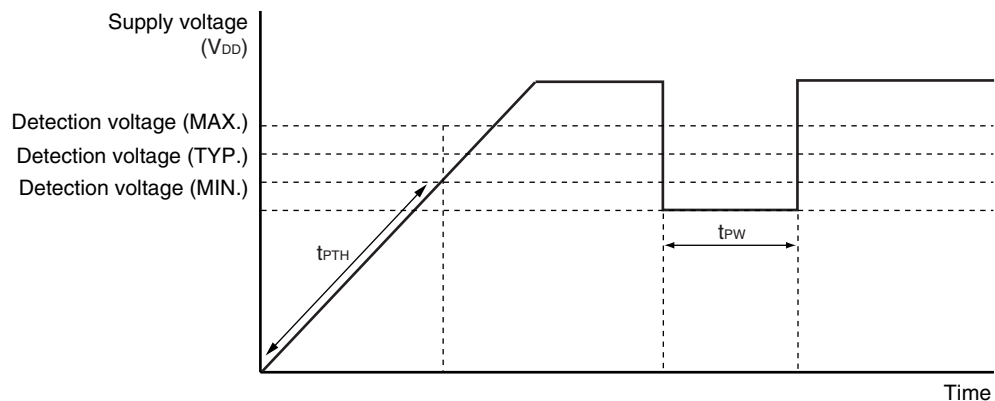
POC Circuit Timing

Supply Voltage Rise Time ($T_A = -40$ to $+85^\circ\text{C}$, $V_{SS} = EV_{SS} = 0$ V)

Parameter	Symbol	Conditions	MIN.	TYP.	MAX.	Unit
Maximum time to rise to 1.8 V (V_{DD} (MIN.)) ($V_{DD}: 0$ V \rightarrow 1.8 V)	t_{PUP1}	POCMODE (option byte) = 0, when $\overline{\text{RESET}}$ input is not used			3.6	ms
Maximum time to rise to 1.8 V (V_{DD} (MIN.)) (releasing $\overline{\text{RESET}}$ input \rightarrow $V_{DD}: 1.8$ V)	t_{PUP2}	POCMODE (option byte) = 0, when $\overline{\text{RESET}}$ input is used			1.9	ms

Supply Voltage Rise Time Timing

- When $\overline{\text{RESET}}$ pin input is not used

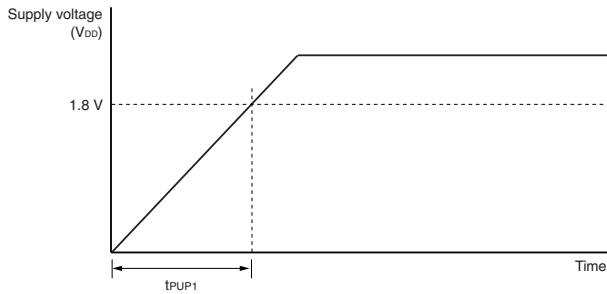

- When $\overline{\text{RESET}}$ pin input is used

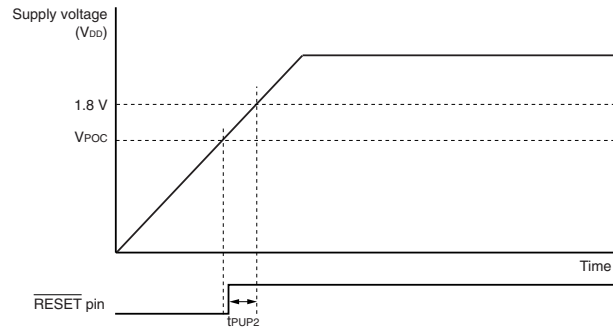

2.7 V POC Circuit Characteristics ($T_A = -40$ to $+85^\circ\text{C}$, $V_{SS} = EV_{SS} = 0$ V)

Parameter	Symbol	Conditions	MIN.	TYP.	MAX.	Unit
Detection voltage on application of supply voltage	V_{DDPOC}	POCMODE (option byte) = 1	2.50	2.70	2.90	V

LVI Circuit Characteristics (T_A = -40 to +85°C, V_{POC} ≤ V_{DD} = EV_{DD} ≤ 5.5 V, AV_{REF} ≤ V_{DD}, V_{SS} = EV_{SS} = 0 V)

Parameter	Symbol	Conditions	MIN.	TYP.	MAX.	Unit	
Detection voltage	Supply voltage level	V _{LV10}		4.14	4.24	4.34	V
		V _{LV11}		3.99	4.09	4.19	V
		V _{LV12}		3.83	3.93	4.03	V
		V _{LV13}		3.68	3.78	3.88	V
		V _{LV14}		3.52	3.62	3.72	V
		V _{LV15}		3.37	3.47	3.57	V
		V _{LV16}		3.22	3.32	3.42	V
		V _{LV17}		3.06	3.16	3.26	V
		V _{LV18}		2.91	3.01	3.11	V
		V _{LV19}		2.75	2.85	2.95	V
		V _{LV110}		2.60	2.70	2.80	V
		V _{LV111}		2.45	2.55	2.65	V
		V _{LV112}		2.29	2.39	2.49	V
		V _{LV113}		2.14	2.24	2.34	V
		V _{LV114}		1.98	2.08	2.18	V
		V _{LV115}		1.83	1.93	2.03	V
External input pin ^{Note 1}	EXLVI	EXLVI < V _{DD} , 1.8 V ≤ V _{DD} ≤ 5.5 V		1.21		V	
Minimum pulse width	t _{LW}		200			μs	
Operation stabilization wait time ^{Note 2}	t _{LWAIT}				10	μs	

Notes 1. The EXLVI/P120/INTP0 pin is used.

2. Time required from setting bit 7 (LVION) of the low-voltage detection register (LVIM) to 1 to operation stabilization

Remark V_{LV(n-1)} > V_{LVn}; n = 1 to 15

LVI Circuit Timing

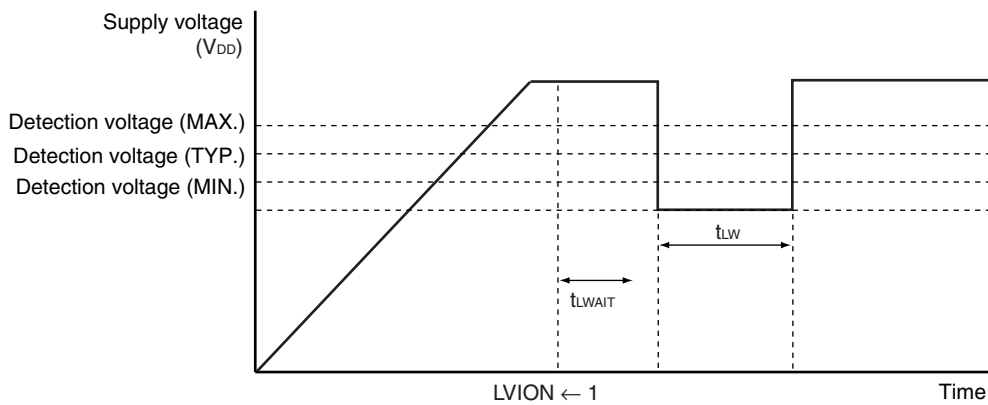

Data Memory STOP Mode Low Supply Voltage Data Retention Characteristics (T_A = -40 to +85°C)

Parameter	Symbol	Conditions	MIN.	TYP.	MAX.	Unit
Data retention supply voltage	V _{DDDR}		1.44 ^{Note}		5.5	V

Note The value depends on the POC detection voltage. When the voltage drops, the data is retained until a POC reset is effected, but data is not retained when a POC reset is effected.

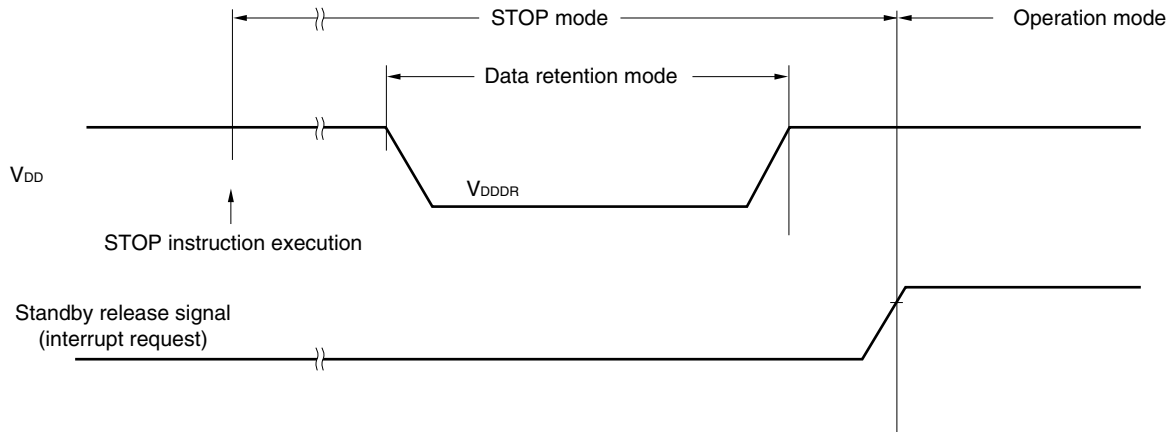

Flash Memory Programming Characteristics

(TA = -40 to +85°C, 2.7 V ≤ VDD = EVDD ≤ 5.5 V, AVREF ≤ VDD, VSS = EVSS = AVSS = 0 V)

(1) Basic characteristics

Parameter	Symbol	Conditions	MIN.	TYP.	MAX.	Unit
VDD supply current	IDD	fXP = 10 MHz (TYP.), 20 MHz (MAX.)		4.5	11.0	mA
Erase time ^{Note 1}	All block	T _{eraca}		20	200	ms
	Block unit	T _{erasa}		20	200	ms
Write time	T _{wrwa}			TBD	TBD	μs
Number of rewrites per chip	C _{erwr}	Retention: 10 years 1 erase + 1 write after erase = 1 rewrite ^{Note 2}	100			Times

Notes 1. The prewrite time before erasure and the erase verify time (writeback time) are not included.

- 2.** When a product is first written after shipment, “erase → write” and “write only” are both taken as one rewrite.

Remark f_{XP}: Main system clock oscillation frequency

(2) Serial write operation characteristics

Parameter	Symbol	Conditions	MIN.	TYP.	MAX.	Unit
Time from $\overline{\text{RESET}}\uparrow$ to FLMD0 count start	T _{RFCF}		4.1		17.1	ms
Count execution time	T _{COUNT}		10.8		13.2	ms
FLMD0 counter high-/low-level width	T _{CH} /T _{CL}		T _C × 0.45			μs
FLMD0 counter rise/fall time	T _R /T _F		12.5			μs

Remark These values may change after evaluation.

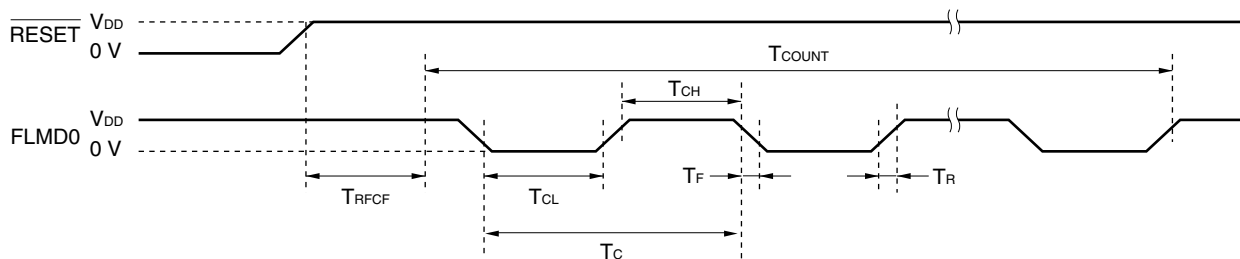
Serial Write Operation

CHAPTER 30 PACKAGE DRAWINGS

64-PIN PLASTIC LQFP(FINE PITCH)(10x10)

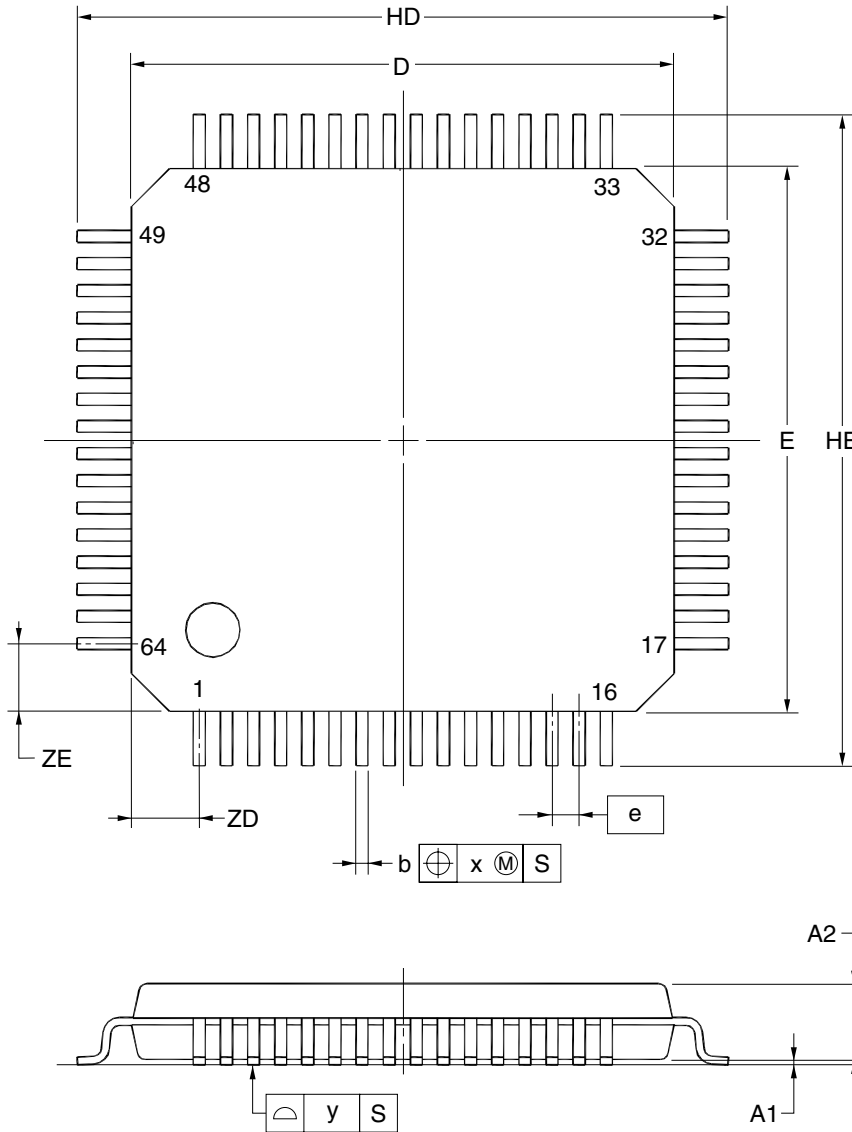

(UNIT:mm)

ITEM	DIMENSIONS
D	10.00±0.20
E	10.00±0.20
HD	12.00±0.20
HE	12.00±0.20
A	1.60 MAX.
A1	0.10±0.05
A2	1.40±0.05
A3	0.25
b	0.22±0.05
c	0.145 ^{+0.055} _{-0.045}
L	0.50
Lp	0.60±0.15
L1	1.00±0.20
θ	3°+5° -3°
e	0.50
x	0.08
y	0.08
ZD	1.25
ZE	1.25

P64GB-50-UEU-1

NOTE
Each lead centerline is located within 0.08 mm of its true position at maximum material condition.

64-PIN PLASTIC LQFP(14x14)

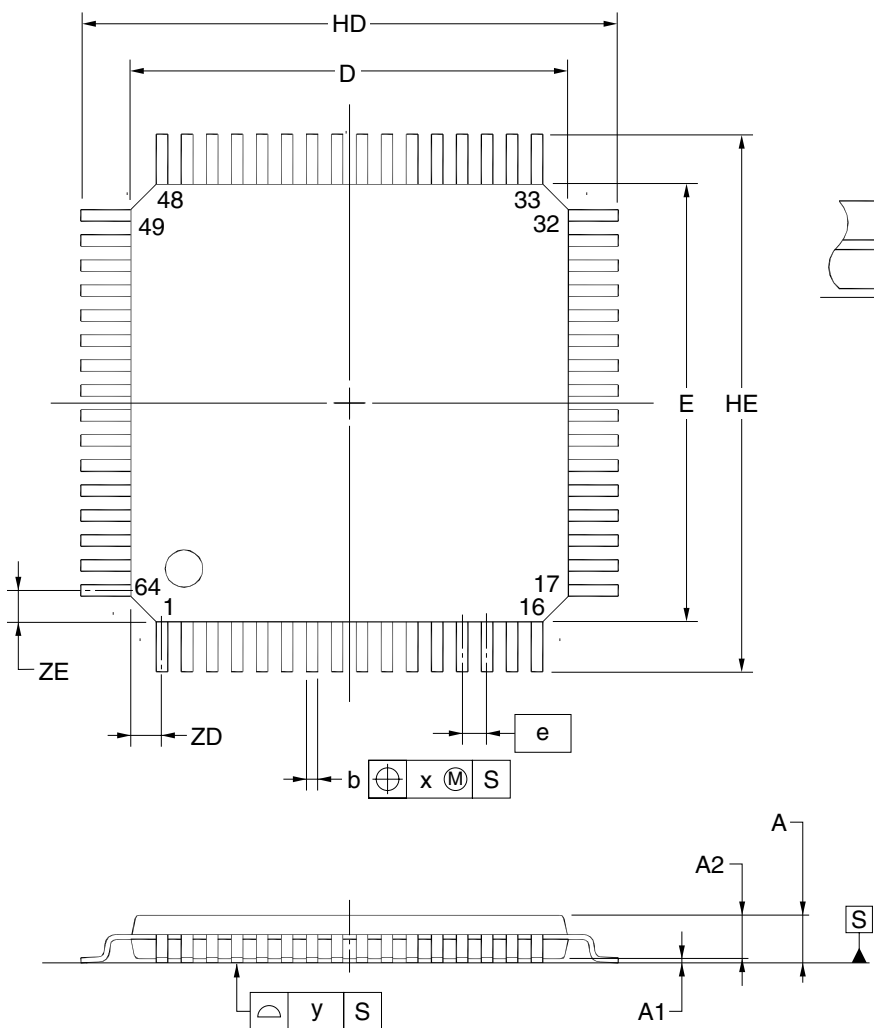

(UNIT:mm)

ITEM	DIMENSIONS
D	14.00±0.20
E	14.00±0.20
HD	17.20±0.20
HE	17.20±0.20
A	1.70 MAX.
A1	0.125±0.075
A2	1.40±0.05
A3	0.25
b	0.37 ^{+0.08} _{-0.07}
c	0.17 ^{+0.03} _{-0.06}
L	0.80
Lp	0.886±0.15
L1	1.60±0.20
θ	3° ^{+5°} _{-3°}
e	0.80
x	0.20
y	0.10
ZD	1.00
ZE	1.00

P64GC-80-UBS

NOTE

Each lead centerline is located within 0.20 mm of its true position at maximum material condition.

64-PIN PLASTIC LQFP(12x12)

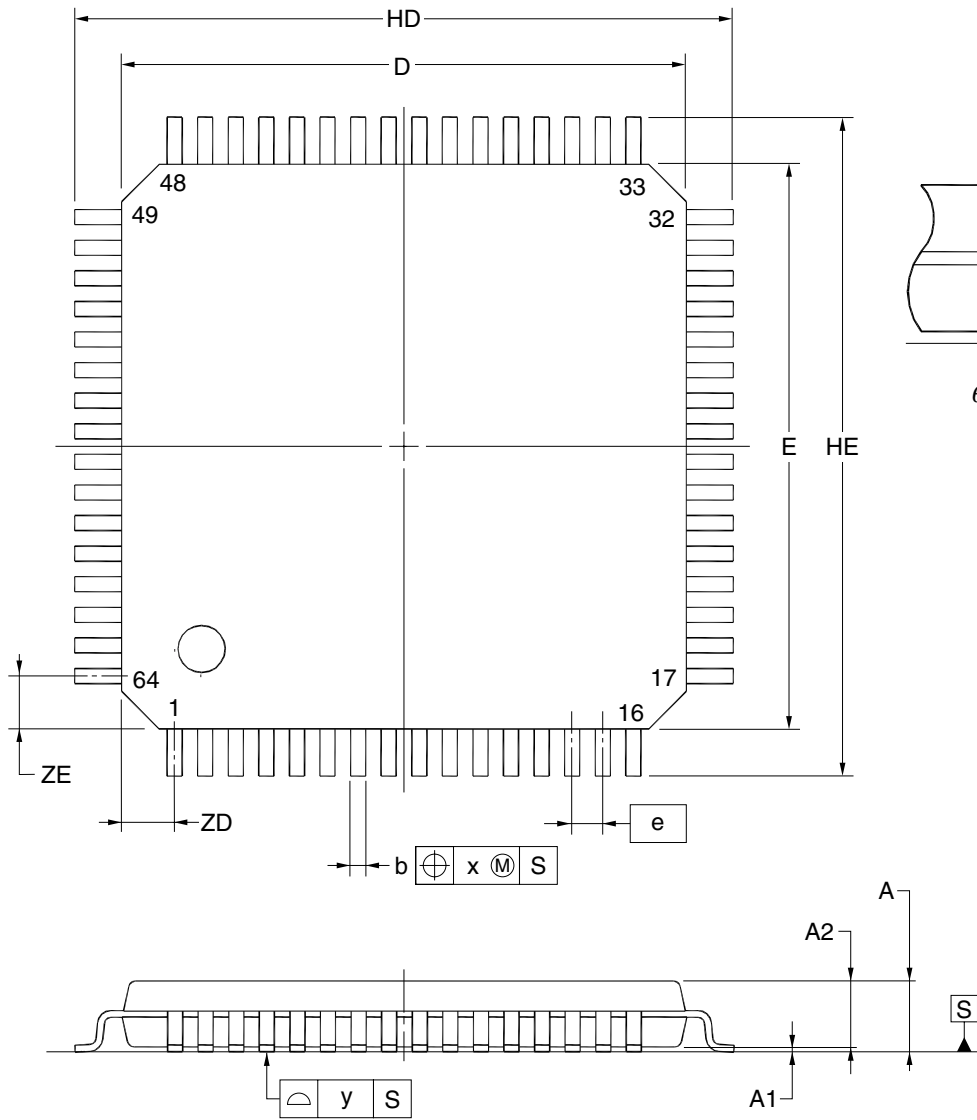

NOTE
Each lead centerline is located within 0.13 mm of its true position at maximum material condition.

(UNIT:mm)

ITEM	DIMENSIONS
D	12.00±0.20
E	12.00±0.20
HD	14.00±0.20
HE	14.00±0.20
A	1.60 MAX.
A1	0.10±0.05
A2	1.40±0.05
A3	0.25
b	0.32 ^{+0.08} _{-0.07}
c	0.145 ^{+0.055} _{-0.045}
L	0.50
Lp	0.60±0.15
L1	1.00±0.20
θ	3° ^{+5°} _{-3°}
e	0.65
x	0.13
y	0.10
ZD	1.125
ZE	1.125

P64GK-65-UET-1

64-PIN PLASTIC TQFP(FINE PITCH)(7x7)

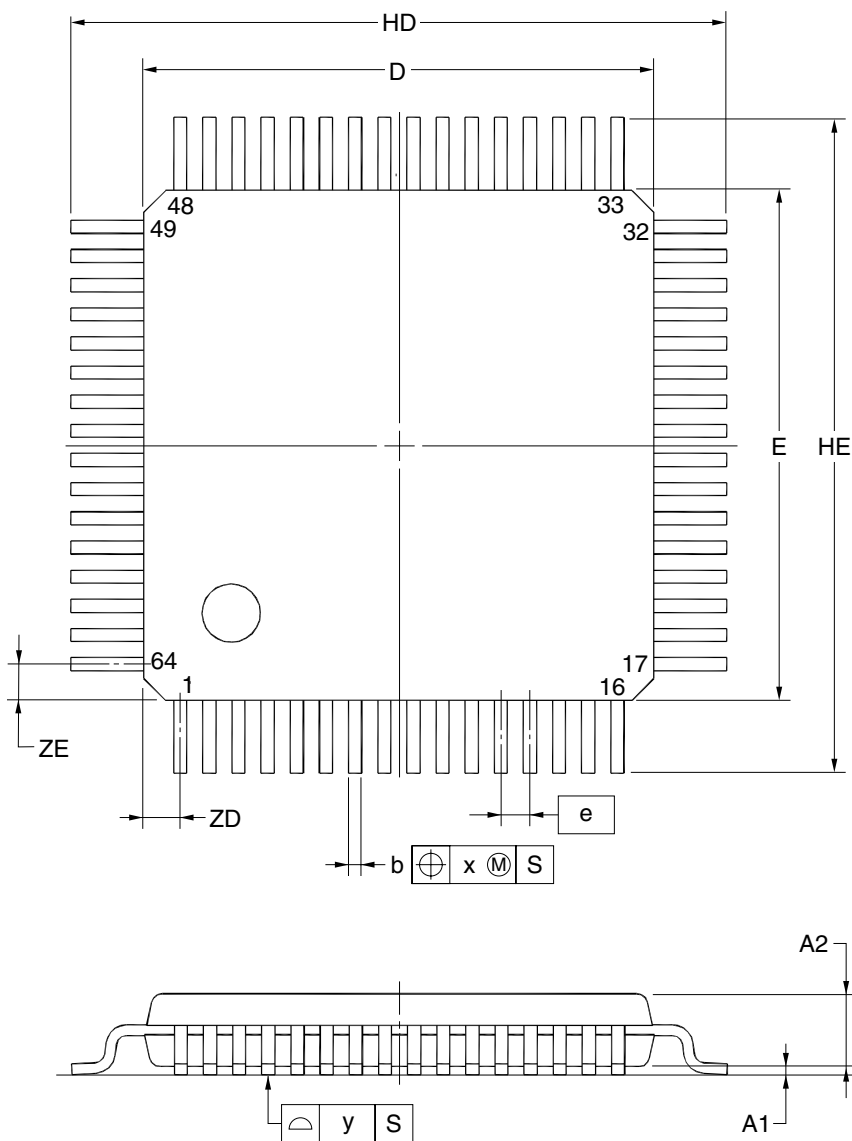

detail of lead end

(UNIT:mm)

ITEM	DIMENSIONS
D	7.00±0.20
E	7.00±0.20
HD	9.00±0.20
HE	9.00±0.20
A	1.20 MAX.
A1	0.10±0.05
A2	1.00±0.05
A3	0.25
b	0.18±0.05
c	0.145 ^{+0.055} _{-0.045}
L	0.50
Lp	0.60±0.15
L1	1.00±0.20
θ	3° ^{+5°} _{-3°}
e	0.40
x	0.07
y	0.08
ZD	0.50
ZE	0.50

NOTE

Each lead centerline is located within 0.07 mm of its true position at maximum material condition.

P64GA-40-9EV-1

64-PIN PLASTIC FLGA(5x5)

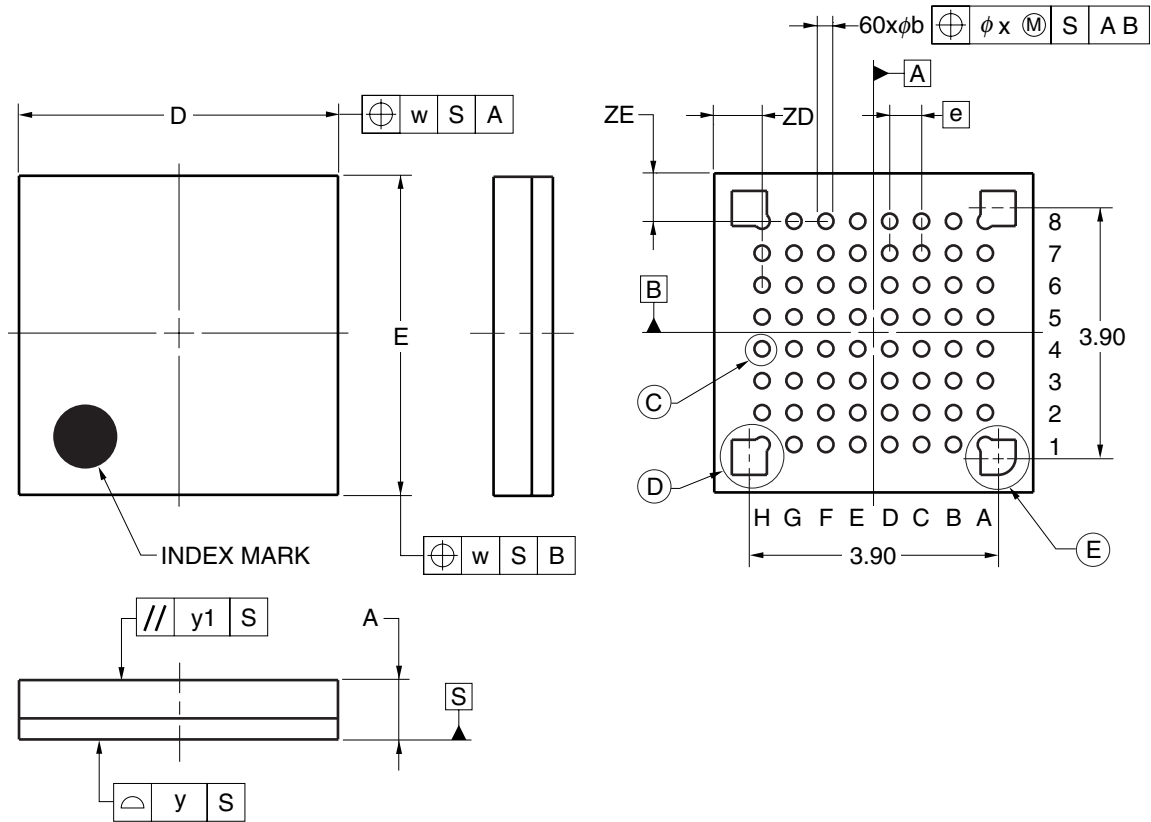

DETAIL OF (C) PART

DETAIL OF (D) PART

DETAIL OF (E) PART

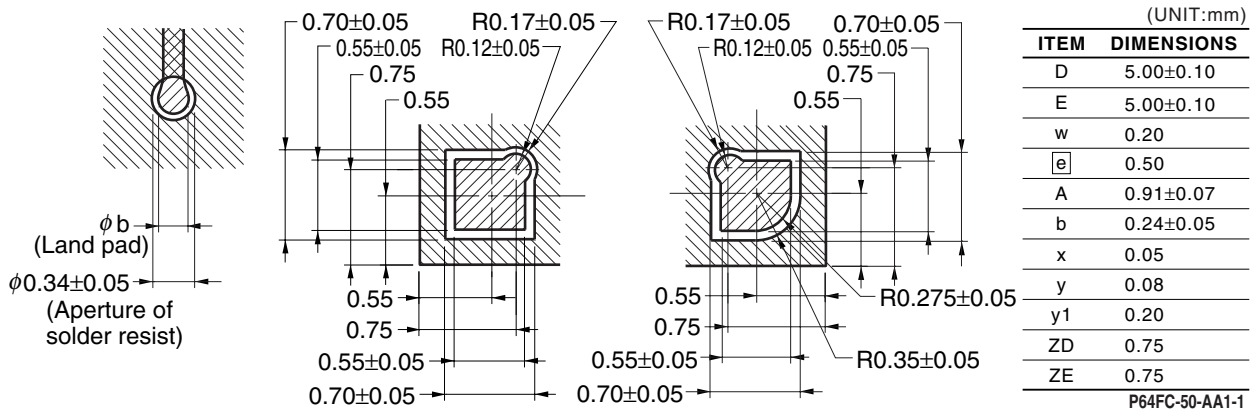

(UNIT:mm)

ITEM	DIMENSIONS
D	5.00±0.10
E	5.00±0.10
w	0.20
e	0.50
A	0.91±0.07
b	0.24±0.05
x	0.05
y	0.08
y1	0.20
ZD	0.75
ZE	0.75

P64FC-50-AA1-1

CHAPTER 31 CAUTIONS FOR WAIT

31.1 Cautions for Wait

This product has two internal system buses.

One is a CPU bus and the other is a peripheral bus that interfaces with the low-speed peripheral hardware.

Because the clock of the CPU bus and the clock of the peripheral bus are asynchronous, unexpected illegal data may be passed if an access to the CPU conflicts with an access to the peripheral hardware.

When accessing the peripheral hardware that may cause a conflict, therefore, the CPU repeatedly executes processing, until the correct data is passed.

As a result, the CPU does not start the next instruction processing but waits. If this happens, the number of execution clocks of an instruction increases by the number of wait clocks (for the number of wait clocks, see **Tables 31-1**). This must be noted when real-time processing is performed.

31.2 Peripheral Hardware That Generates Wait

Table 31-1 lists the registers that issue a wait request when accessed by the CPU, and the number of CPU wait clocks.

Table 31-1. Registers That Generate Wait and Number of CPU Wait Clocks

Peripheral Hardware	Register	Access	Number of Wait Clocks
Serial interface UART0	ASIS0	Read	1 clock (fixed)
Serial interface UART6	ASIS6	Read	1 clock (fixed)
Serial interface IIC0	IICS0	Read	1 clock (fixed)
A/D converter	ADM	Write	1 to 5 clocks (when $f_{AD} = f_{PRS}/2$ is selected)
	ADS	Write	1 to 7 clocks (when $f_{AD} = f_{PRS}/3$ is selected)
	ADPC	Write	1 to 9 clocks (when $f_{AD} = f_{PRS}/4$ is selected)
	ADCR	Read	2 to 13 clocks (when $f_{AD} = f_{PRS}/6$ is selected)
			2 to 17 clocks (when $f_{AD} = f_{PRS}/8$ is selected)
			2 to 25 clocks (when $f_{AD} = f_{PRS}/12$ is selected)
<p>The above number of clocks is when the same source clock is selected for f_{CPU} and f_{PRS}. The number of wait clocks can be calculated by the following expression and under the following conditions.</p> <p><Calculating number of wait clocks></p> <ul style="list-style-type: none"> Number of wait clocks = $\{(1/f_{AD}) \times 2 / (1/f_{CPU})\} + 1$ <ul style="list-style-type: none"> * Fraction is truncated if the number of wait clocks ≤ 0.5 and rounded up if the number of wait clocks > 0.5. <p>f_{AD}: A/D conversion clock frequency ($f_{PRS}/2$ to $f_{PRS}/12$)</p> <p>f_{CPU}: CPU clock frequency</p> <p>f_{PRS}: Peripheral hardware clock frequency</p> <p>f_{XP}: Main system clock frequency</p> <p><Conditions for maximum/minimum number of wait clocks></p> <ul style="list-style-type: none"> Maximum number of times: Maximum speed of CPU (f_{XP}), lowest speed of A/D conversion clock ($f_{PRS}/12$) Minimum number of times: Minimum speed of CPU ($f_{SUB}/2$), highest speed of A/D conversion clock ($f_{PRS}/2$) 			

Caution When the CPU is operating on the subsystem clock and the peripheral hardware clock is stopped, do not access the registers listed above using an access method in which a wait request is issued.

Remark The clock is the CPU clock (f_{CPU}).

APPENDIX A DEVELOPMENT TOOLS

The following development tools are available for the development of systems that employ the 78K0/KE2. Figure A-1 shows the development tool configuration.

- **Support for PC98-NX series**

Unless otherwise specified, products supported by IBM PC/AT™ compatibles are compatible with PC98-NX series computers. When using PC98-NX series computers, refer to the explanation for IBM PC/AT compatibles.

- **Windows™**

Unless otherwise specified, "Windows" means the following OSs.

- Windows 98
- Windows NT™
- Windows 2000
- Windows XP

Figure A-1. Development Tool Configuration (1/2)

(1) When using the in-circuit emulator QB-78K0KX2

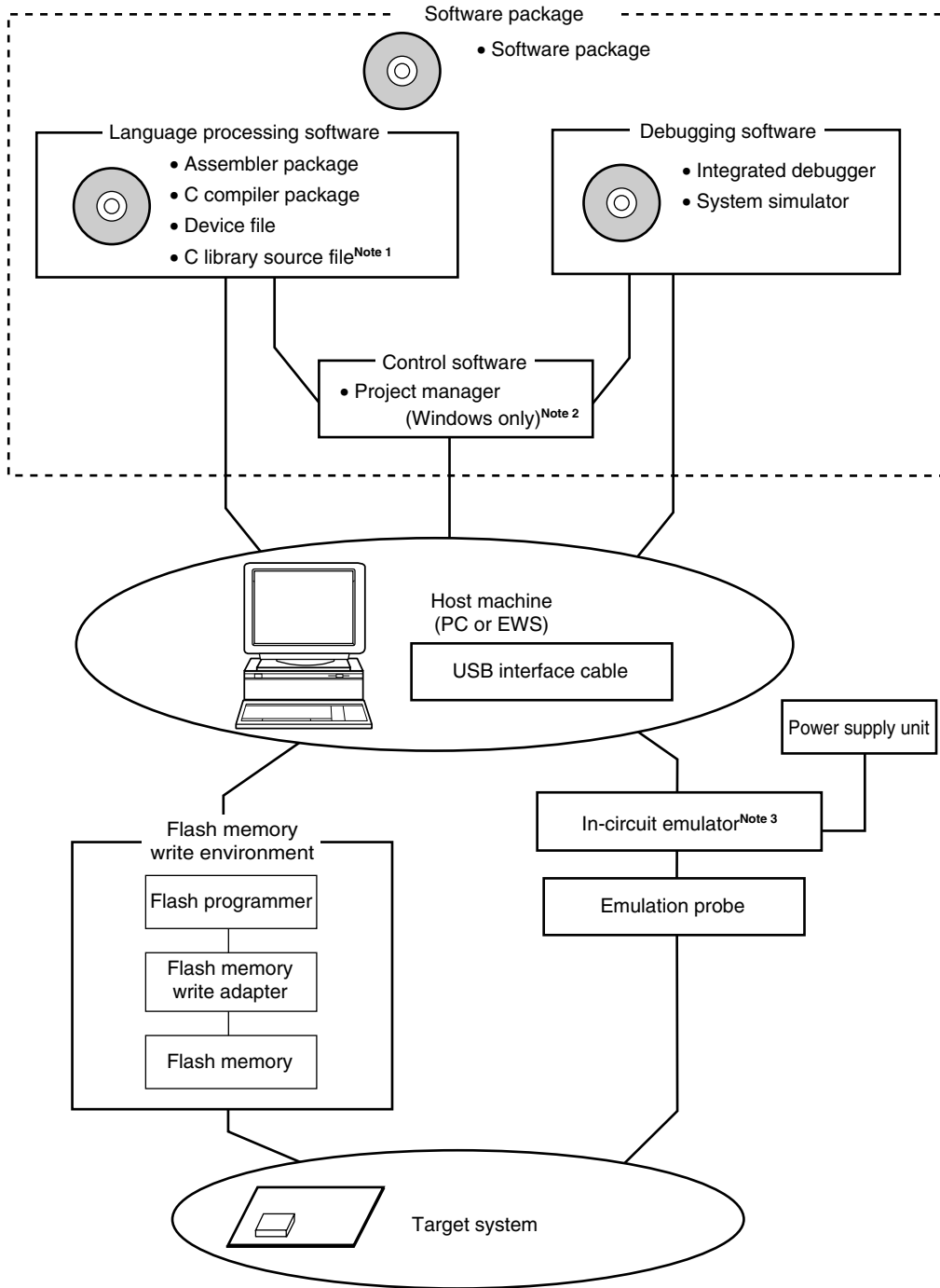

- Notes**
1. The C library source file is not included in the software package.
 2. The project manager PM+ is included in the assembler package. The PM+ is only used for Windows.
 3. In-circuit emulator QB-78K0KX2 is supplied with integrated debugger ID78K0-QB, simple flash memory programmer PG-FPL3, power supply unit, and USB interface cable. Any other products are sold separately.

Figure A-1. Development Tool Configuration (2/2)

★ (2) When using the on-chip debug emulator QB-78K0MINI

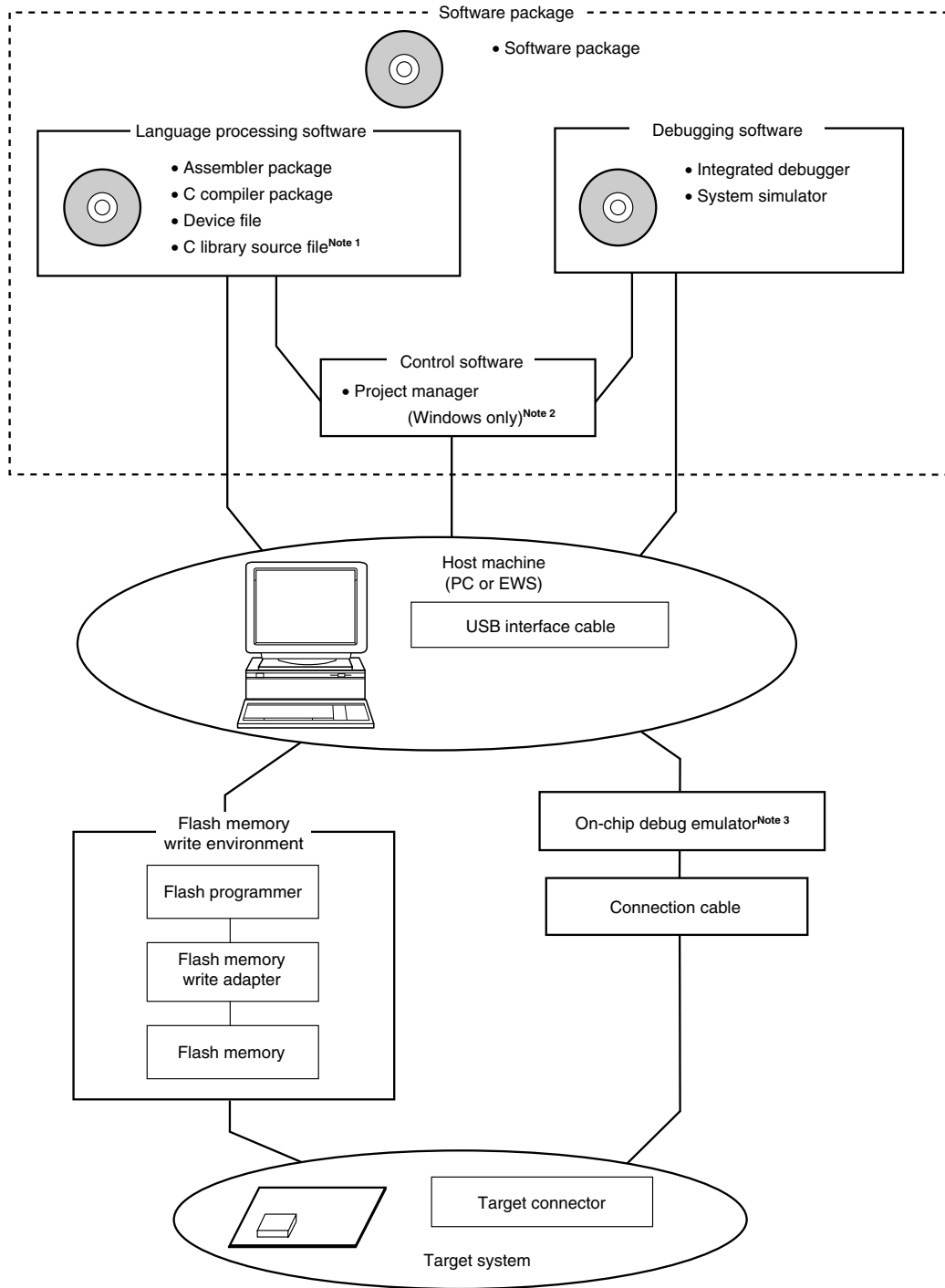

- Notes**
1. The C library source file is not included in the software package.
 2. The project manager PM+ is included in the assembler package. The PM+ is only used for Windows.
 3. The on-chip debug emulator QB-78K0MINI is supplied with integrated debugger ID78K0-QB, USB interface cable, and connection cable. Any other products are sold separately.

A.1 Software Package

SP78K0 78K/0 Series software package	Development tools (software) common to the 78K/0 Series are combined in this package. Part number: μ SxxxxSP78K0
-----------------------------------------	-------------------------------------------------------------------------------------------------------------------------

Remark xxxx in the part number differs depending on the host machine and OS used.

μ SxxxxSP78K0

xxxx	Host Machine	OS	Supply Medium
AB17	PC-9800 series,	Windows (Japanese version)	CD-ROM
BB17	IBM PC/AT compatibles	Windows (English version)	

A.2 Language Processing Software

RA78K0 Assembler package	<p>This assembler converts programs written in mnemonics into object codes executable with a microcontroller.</p> <p>This assembler is also provided with functions capable of automatically creating symbol tables and branch instruction optimization.</p> <p>This assembler should be used in combination with a device file (DF780547) (sold separately).</p> <p><Precaution when using RA78K0 in PC environment></p> <p>This assembler package is a DOS-based application. It can also be used in Windows, however, by using the Project Manager (included in assembler package) on Windows.</p> <p>Part number: μSxxxxRA78K0</p>
CC78K0 C compiler package	<p>This compiler converts programs written in C language into object codes executable with a microcontroller.</p> <p>This compiler should be used in combination with an assembler package and device file (both sold separately).</p> <p><Precaution when using CC78K0 in PC environment></p> <p>This C compiler package is a DOS-based application. It can also be used in Windows, however, by using the Project Manager (included in assembler package) on Windows.</p> <p>Part number: μSxxxxCC78K0</p>
DF780547 ^{Note 1} Device file	<p>This file contains information peculiar to the device.</p> <p>This device file should be used in combination with a tool (RA78K0, CC78K0, SM+ for 78K0/KX2, and ID78K0-QB) (all sold separately).</p> <p>The corresponding OS and host machine differ depending on the tool to be used.</p> <p>Part number: μSxxxxDF780547</p>
CC78K0-L ^{Note 2} C library source file	<p>This is a source file of the functions that configure the object library included in the C compiler package.</p> <p>This file is required to match the object library included in the C compiler package to the user's specifications.</p> <p>Part number: μSxxxxCC78K0-L</p>

- Notes**
1. The DF780547 can be used in common with the RA78K0, CC78K0, SM+ for 78K0/KX2, and ID78K0-QB.
 2. The CC78K0-L is not included in the software package (SP78K0).

Remark xxxx in the part number differs depending on the host machine and OS used.

μSxxxxRA78K0
 μSxxxxCC78K0
 μSxxxxCC78K0-L

xxxx	Host Machine	OS	Supply Medium
AB17	PC-9800 series, IBM PC/AT compatibles	Windows (Japanese version)	CD-ROM
BB17		Windows (English version)	
3P17	HP9000 series 700™	HP-UX™ (Rel. 10.10)	
3K17	SPARCstation™	SunOS™ (Rel. 4.1.4) Solaris™ (Rel. 2.5.1)	

μSxxxxDF780547

xxxx	Host Machine	OS	Supply Medium
AB13	PC-9800 series, IBM PC/AT compatibles	Windows (Japanese version)	3.5-inch 2HD FD
BB13		Windows (English version)	

A.3 Control Software

PM+ Project manager	<p>This is control software designed to enable efficient user program development in the Windows environment. All operations used in development of a user program, such as starting the editor, building, and starting the debugger, can be performed from the project manager.</p> <p><Caution> The project manager is included in the assembler package (RA78K0). It can only be used in Windows.</p>
------------------------	-----------------------------------------------------------------------------------------------------------------------------------------------------------------------------------------------------------------------------------------------------------------------------------------------------------------------------------------------------------------------------------------------------------------------------------------------------------------

A.4 Flash Memory Writing Tools

FlashPro4 (part number: FL-PR4, PG-FP4) Flash memory programmer	Flash memory programmer dedicated to microcontrollers with on-chip flash memory.
FlashPro4 (part number: PG-FPL3) Simple flash memory programmer	Simple flash memory programmer dedicated to microcontrollers with on-chip flash memory.
FA-64GB-8EU-A FA-64GC-8BS-A FA-78F0537GK-UET-MX FA-78F0537GA-9EV-MX FA-78F0537FC-AA1-MX Flash memory writing adapter	<p>Flash memory writing adapter used connected to the FlashPro4.</p> <ul style="list-style-type: none"> • FA-64GB-8EU-A: For 64-pin plastic LQFP (GB-UEU type) • FA-64GC-8BS-A: For 64-pin plastic LQFP (GC-UBS type) • FA-78F0537GK-UET-MX: For 64-pin plastic LQFP (GK-UET type) • FA-78F0537GA-9EV-MX: For 64-pin plastic TQFP (GA-9EV type) • FA-78F0537FC-AA1-MX: For 64-pin plastic FLGA (FC-AA1 type)

Remark FL-PR4, FA-64GA-8EU-A, FA-64GC-8BS-A, FA-78F0537GK-UET-MX, FA-78F0537GA-9EV-MX, and FA-78F0537FC-AA1-MX are products of Naito Densai Machida Mfg. Co., Ltd.
 TEL: +81-45-475-4191 Naito Densai Machida Mfg. Co., Ltd.

A.5 Debugging Tools (Hardware)

A.5.1 When using in-circuit emulator QB-78K0KX2

QB-78K0KX2 ^{Note 1} In-circuit emulator	This in-circuit emulator serves to debug hardware and software when developing application systems using the 78K0/Kx2. It supports to the integrated debugger (ID78K0-QB). This emulator should be used in combination with a power supply unit and emulation probe, and the USB is used to connect this emulator to the host machine.
QB-144-CA-01 Check pin adapter	This check pin adapter is used in waveform monitoring using the oscilloscope, etc.
QB-80-EP-01T Emulation probe	This emulation probe is flexible type and used to connect the in-circuit emulator and target system.
QB-64GB-EA-04T, QB-64GC-EA-03T, QB-64GK-EA-04T, QB-64GA-EA-01T, QB-64FC-EA-01T Exchange adapter	This exchange adapter is used to perform pin conversion from the in-circuit emulator to target connector. <ul style="list-style-type: none"> • QB-64GB-EA-04T: 64-pin plastic LQFP (GB-UEU type) • QB-64GC-EA-03T: 64-pin plastic LQFP (GC-UBS type) • QB-64GK-EA-04T: 64-pin plastic LQFP (GK-UET type) • QB-64GA-EA-01T: 64-pin plastic TQFP (GA-9EV type) • QB-64FC-EA-01T: 64-pin plastic FLGA (FC-AA1 type)
QB-64GB-YS-01T, QB-64GC-YS-01T, QB-64GK-YS-01T, QB-64GA-YS-01T Space adapter	This space adapter is used to adjust the height between the target system and in-circuit emulator. <ul style="list-style-type: none"> • QB-64GB-YS-01T: 64-pin plastic LQFP (GB-UEU type) • QB-64GC-YS-01T: 64-pin plastic LQFP (GC-UBS type) • QB-64GK-YS-01T: 64-pin plastic LQFP (GK-UET type) • QB-64GA-YS-01T: 64-pin plastic TQFP (GA-9EV type)
QB-64GB-YQ-01T, QB-64GC-YQ-01T, QB-64GK-YQ-01T, QB-64GA-YQ-01T YQ connector	This YQ connector is used to connect the target connector and exchange adapter. <ul style="list-style-type: none"> • QB-64GB-YQ-01T: 64-pin plastic LQFP (GB-UEU type) • QB-64GC-YQ-01T: 64-pin plastic LQFP (GC-UBS type) • QB-64GK-YQ-01T: 64-pin plastic LQFP (GK-UET type) • QB-64GA-YQ-01T: 64-pin plastic TQFP (GA-9EV type)
QB-64GB-HQ-01T, QB-64GC-HQ-01T, QB-64GK-HQ-01T, QB-64GA-HQ-01T Mount adapter	This mount adapter is used to mount the target device with socket. <ul style="list-style-type: none"> • QB-64GB-HQ-01T: 64-pin plastic LQFP (GB-UEU type) • QB-64GC-HQ-01T: 64-pin plastic LQFP (GC-UBS type) • QB-64GK-HQ-01T: 64-pin plastic LQFP (GK-UET type) • QB-64GA-HQ-01T: 64-pin plastic TQFP (GA-9EV type)
QB-64GB-NQ-01T, QB-64GC-NQ-01T, QB-64GK-NQ-01T, QB-64GA-NQ-01T, QB-64FC-NQ-01T Target connector	This target connector is used to mount on the target system. <ul style="list-style-type: none"> • QB-64GB-NQ-01T: 64-pin plastic LQFP (GB-UEU type) • QB-64GC-NQ-01T: 64-pin plastic LQFP (GC-UBS type) • QB-64GK-NQ-01T: 64-pin plastic LQFP (GK-UET type) • QB-64GA-NQ-01T: 64-pin plastic TQFP (GA-9EV type) • QB-64FC-NQ-01T: 64-pin plastic LQFP (FC-AA1 type)

Note The QB-78K0KX2 is supplied with a power supply unit and USB interface cable. As control software, the integrated debugger ID78K0-QB and simple flash memory programmer PG-FPL3 are supplied.

Remark The packed contents differ depending on the part number, as follows.

Packed Contents Part Number	In-Circuit Emulator	Emulation Probe	Exchange Adapter	YQ Connector	Target Connector
QB-78K0KX2-ZZZ	QB-78K0KX2	None			
QB-78K0KX2-T64GB		QB-80-EP-01T	QB-64GB-EA-04T	QB-64GB-YQ-01T	QB-64GB-NQ-01T
QB-78K0KX2-T64GC			QB-64GC-EA-03T	QB-64GC-YQ-01T	QB-64GC-NQ-01T
QB-78K0KX2-T64GK			QB-64GK-EA-04T	QB-64GK-YQ-01T	QB-64GK-NQ-01T
QB-78K0KX2-T64GA			QB-64GA-EA-01T	QB-64GA-YQ-01T	QB-64GA-NQ-01T
QB-78K0KX2-T64FC			QB-64FC-EA-01T	None	QB-64FC-NQ-01T

★ **A.5.2 When using on-chip debug emulator QB-78K0MINI**

QB-78K0MINI ^{Note} On-chip debug emulator	This on-chip debug emulator serves to debug hardware and software when developing application systems using the 78K0/Kx2. It supports the integrated debugger (ID78K0-QB). This emulator should be used in combination with a connection cable and a USB interface cable that is used to connect the host machine.
Target connector specifications	10-pin general-purpose connector (2.54 mm pitch)

Note The QB-78K0MINI is supplied with a USB interface cable and a connection cable. As control software, the integrated debugger ID78K0-QB is supplied.

A.6 Debugging Tools (Software)

SM+ for 78K0/KX2 System simulator	<p>The SM+ for 78K0/KX2 is Windows-based software. It is used to perform debugging at the C source level or assembler level while simulating the operation of the target system on a host machine. Use of the SM+ for 78K0/KX2 allows the execution of application logical testing and performance testing on an independent basis from hardware development, thereby providing higher development efficiency and software quality. The SM+ for 78K0/KX2 should be used in combination with the device file (DF780547) (sold separately).</p> <p>Part number: SM780547-B</p>
ID78K0-QB Integrated debugger	<p>This debugger supports the in-circuit emulators for the 78K/0 Series. The ID78K0-QB is Windows-based software. It has improved C-compatible debugging functions and can display the results of tracing with the source program using an integrating window function that associates the source program, disassemble display, and memory display with the trace result. It should be used in combination with the device file (sold separately).</p> <p>Part number: μSxxxxID78K0-QB</p>

Remark xxxx in the part number differs depending on the host machine and OS used.

μ SxxxxSM780547-B

μ SxxxxID78K0-QB

xxxx	Host Machine	OS	Supply Medium
AB17	PC-9800 series, IBM PC/AT compatibles	Windows (Japanese version)	CD-ROM
BB17		Windows (English version)	

★

APPENDIX B NOTES ON TARGET SYSTEM DESIGN

This chapter shows areas on the target system where component mounting is prohibited and areas where there are component mounting height restrictions when the QB-78K0KX2 is used.

Figure B-1. For 64-Pin GB Package

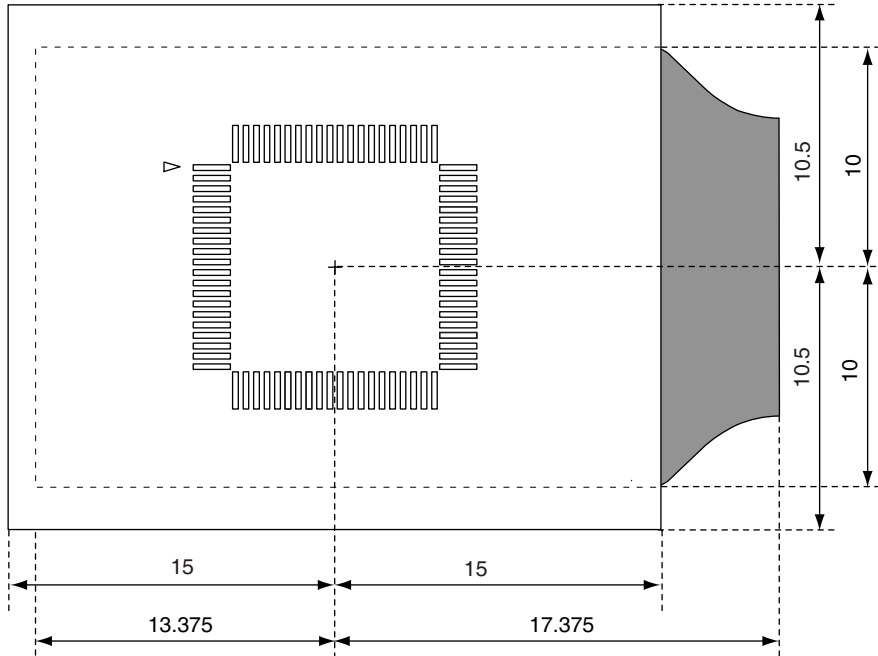

- : Exchange adapter area: Components up to 17.45 mm in height can be mounted^{Note}
- : Emulation probe tip area: Components up to 24.45 mm in height can be mounted^{Note}

Note Height can be adjusted by using space adapters (each adds 2.4 mm)

Figure B-2. For 64-Pin GC Package

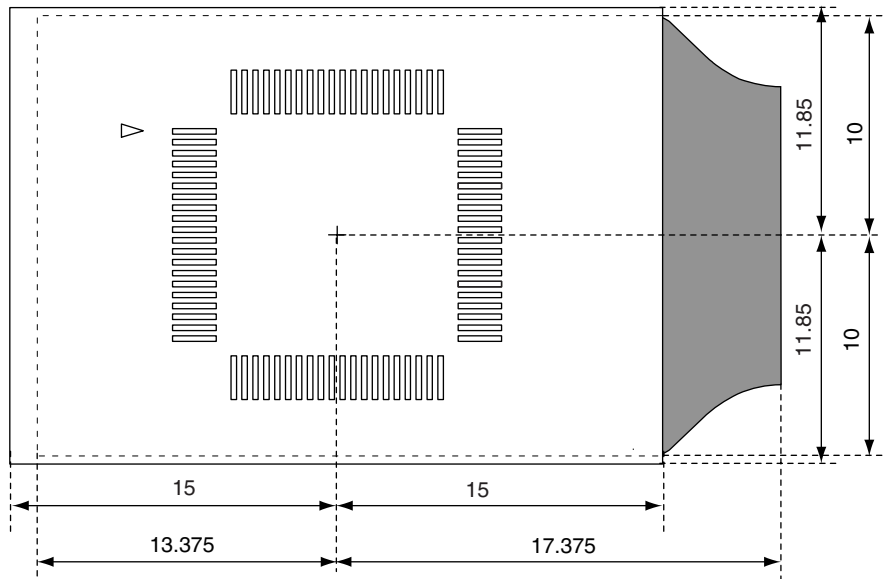

- : Exchange adapter area: Components up to 17.45 mm in height can be mounted^{Note}
- : Emulation probe tip area: Components up to 24.45 mm in height can be mounted^{Note}

Note Height can be adjusted by using space adapters (each adds 2.4 mm)

Figure B-3. For 64-Pin GK Package

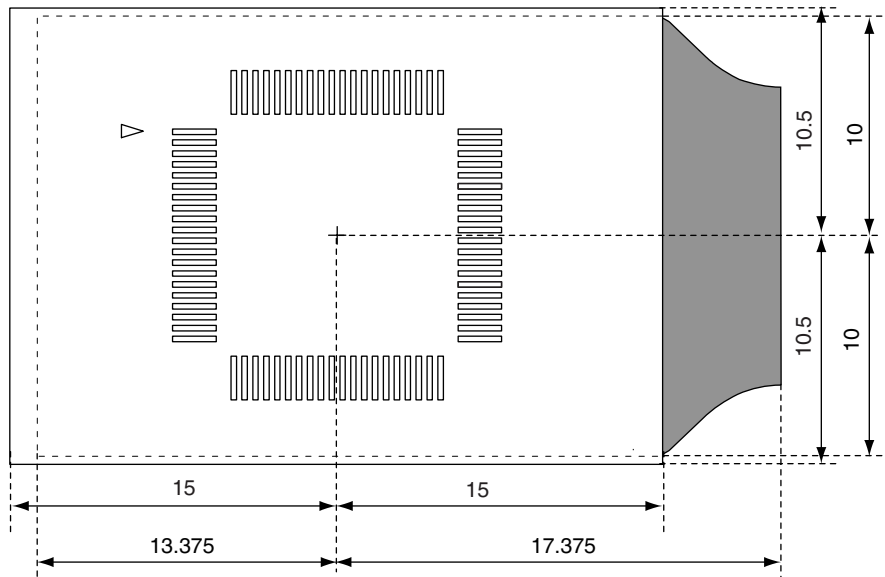

- : Exchange adapter area: Components up to 17.45 mm in height can be mounted^{Note}
- : Emulation probe tip area: Components up to 24.45 mm in height can be mounted^{Note}

Note Height can be adjusted by using space adapters (each adds 2.4 mm)

APPENDIX C REGISTER INDEX

C.1 Register Index (In Alphabetical Order with Respect to Register Names)

[A]

A/D converter mode register (ADM)	307
A/D port configuration register (ADPC)	313
Analog input channel specification register (ADS)	312
Asynchronous serial interface control register 6 (ASICL6)	360
Asynchronous serial interface operation mode register 0 (ASIM0)	330
Asynchronous serial interface operation mode register 6 (ASIM6)	354
Asynchronous serial interface reception error status register 0 (ASIS0)	332
Asynchronous serial interface reception error status register 6 (ASIS6)	356
Asynchronous serial interface transmission status register 6 (ASIF6)	357

[B]

Baud rate generator control register 0 (BRGC0)	333
Baud rate generator control register 6 (BRGC6)	359

[C]

Capture/compare control register 00 (CRC00)	179
Capture/compare control register 01 (CRC01)	179
Clock operation mode select register (OSCCTL)	137
Clock output selection register (CKS)	301
Clock selection register 6 (CKSR6)	358

[E]

8-bit A/D conversion result register (ADCRH)	311
8-bit timer compare register 50 (CR50)	247
8-bit timer compare register 51 (CR51)	247
8-bit timer counter 50 (TM50)	247
8-bit timer counter 51 (TM51)	247
8-bit timer H carrier control register 1 (TMCYC1)	270
8-bit timer H compare register 00 (CMP00)	265
8-bit timer H compare register 01 (CMP01)	265
8-bit timer H compare register 10 (CMP10)	265
8-bit timer H compare register 11 (CMP11)	265
8-bit timer H mode register 0 (TMHMD0)	266
8-bit timer H mode register 1 (TMHMD1)	266
8-bit timer mode control register 50 (TMC50)	250
8-bit timer mode control register 51 (TMC51)	250
External interrupt falling edge enable register (EGN)	497
External interrupt rising edge enable register (EGP)	497

[I]

IIC clock selection register 0 (IICCL0)	421
IIC control register 0 (IICC0)	412

IIC flag register 0 (IICF0)	419
IIC function expansion register 0 (IICX0)	422
IIC shift register 0 (IIC0)	409
IIC status register 0 (IICS0)	417
Input switch control register (ISC)	362
Internal expansion RAM size switching register (IXS)	560
Internal memory size switching register (IMS)	558
Internal oscillation mode register (RCM)	141
Interrupt mask flag register 0H (MK0H)	495
Interrupt mask flag register 0L (MK0L)	495
Interrupt mask flag register 1H (MK1H)	495
Interrupt mask flag register 1L (MK1L)	495
Interrupt request flag register 0H (IF0H)	493
Interrupt request flag register 0L (IF0L)	493
Interrupt request flag register 1H (IF1H)	493
Interrupt request flag register 1L (IF1L)	493
[K]	
Key return mode register (KRM)	507
[L]	
Low-voltage detection level selection register (LVIS)	538
Low-voltage detection register (LVIM)	539
[M]	
Main clock mode register (MCM)	143
Main OSC control register (MOC)	142
Memory bank select register (BANK)	90
Multiplication/division data register A0 (MDA0H, MDA0L)	479
Multiplication/division data register B0 (MDB0)	481
Multiplier/divider control register 0 (DMUC0)	481
[O]	
Oscillation stabilization time counter status register (OSTC)	144, 509
Oscillation stabilization time select register (OSTS)	145, 510
[P]	
Port mode register 0 (PM0)	125, 187, 392
Port mode register 1 (PM1)	125, 252, 270, 334, 362, 392
Port mode register 2 (PM2)	125, 314
Port mode register 3 (PM3)	125, 252
Port mode register 4 (PM4)	125
Port mode register 5 (PM5)	125
Port mode register 6 (PM6)	125, 424
Port mode register 7 (PM7)	125
Port mode register 12 (PM12)	125, 540
Port mode register 14 (PM14)	125, 303
Port register 0 (P0)	127

Port register 1 (P1)	127
Port register 2 (P2)	127
Port register 3 (P3)	127
Port register 4 (P4)	127
Port register 5 (P5)	127
Port register 6 (P6)	127
Port register 7 (P7)	127
Port register 12 (P12)	127
Port register 13 (P13)	127
Port register 14 (P14)	127
Prescaler mode register 00 (PRM00)	184
Prescaler mode register 01 (PRM01)	184
Priority specification flag register 0H (PR0H)	496
Priority specification flag register 0L (PR0L)	496
Priority specification flag register 1H (PR1H)	496
Priority specification flag register 1L (PR1L)	496
Processor clock control register (PCC)	139
Pull-up resistor option register 0 (PU0)	128
Pull-up resistor option register 1 (PU1)	128
Pull-up resistor option register 3 (PU3)	128
Pull-up resistor option register 4 (PU4)	128
Pull-up resistor option register 5 (PU5)	128
Pull-up resistor option register 6 (PU6)	128
Pull-up resistor option register 7 (PU7)	128
Pull-up resistor option register 12 (PU12)	128
Pull-up resistor option register 14 (PU14)	128
[R]	
Receive buffer register 0 (RXB0)	329
Receive buffer register 6 (RXB6)	353
Remainder data register 0 (SDR0)	479
Reset control flag register (RESF)	529
[S]	
Serial clock selection register 10 (CSIC10)	390
Serial clock selection register 11 (CSIC11)	390
Serial I/O shift register 10 (SIO10)	387
Serial I/O shift register 11 (SIO11)	387
Serial operation mode register 10 (CSIM10)	388
Serial operation mode register 11 (CSIM11)	388
16-bit timer capture/compare register 000 (CR000)	173
16-bit timer capture/compare register 001 (CR001)	173
16-bit timer capture/compare register 010 (CR010)	173
16-bit timer capture/compare register 011 (CR011)	173
16-bit timer counter 00 (TM00)	172
16-bit timer counter 01 (TM00)	172

16-bit timer mode control register 00 (TMC00)	176
16-bit timer mode control register 01 (TMC01)	176
16-bit timer output control register 00 (TOC00).....	181
16-bit timer output control register 01 (TOC01).....	181
Slave address register 0 (SVA0).....	409
[T]	
Timer clock selection register 50 (TCL50)	248
Timer clock selection register 51 (TCL51)	248
10-bit A/D conversion result register (ADCR).....	310
Transmit buffer register 10 (SOTB10).....	386
Transmit buffer register 11 (SOTB11).....	386
Transmit buffer register 6 (TXB6).....	353
Transmit shift register 0 (TXS0)	329
[W]	
Watch timer operation mode register (WTM)	289
Watchdog timer enable register (WDTE)	295

C.2 Register Index (In Alphabetical Order with Respect to Register Symbol)**[A]**

ADCR:	10-bit A/D conversion result register.....	310
ADCRH:	8-bit A/D conversion result register.....	311
ADM:	A/D converter mode register.....	307
ADPC:	A/D port configuration register.....	313
ADS:	Analog input channel specification register	312
ASICL6:	Asynchronous serial interface control register 6.....	360
ASIF6:	Asynchronous serial interface transmission status register 6.....	357
ASIM0:	Asynchronous serial interface operation mode register 0.....	330
ASIM6:	Asynchronous serial interface operation mode register 6.....	354
ASIS0:	Asynchronous serial interface reception error status register 0.....	332
ASIS6:	Asynchronous serial interface reception error status register 6.....	356

[B]

BANK:	Memory bank select register	90
BRGC0:	Baud rate generator control register 0.....	333
BRGC6:	Baud rate generator control register 6.....	359

[C]

CKS:	Clock output selection register	301
CKSR6:	Clock selection register 6	358
CMP00:	8-bit timer H compare register 00	265
CMP01:	8-bit timer H compare register 01	265
CMP10:	8-bit timer H compare register 10	265
CMP11:	8-bit timer H compare register 11	265
CR000:	16-bit timer capture/compare register 000.....	173
CR001:	16-bit timer capture/compare register 000.....	173
CR010:	16-bit timer capture/compare register 010.....	173
CR011:	16-bit timer capture/compare register 011.....	173
CR50:	8-bit timer compare register 50.....	247
CR51:	8-bit timer compare register 51.....	247
CRC00:	Capture/compare control register 00	179
CRC01:	Capture/compare control register 01	179
CSIC10:	Serial clock selection register 10.....	390
CSIC11:	Serial clock selection register 11	390
CSIM10:	Serial operation mode register 10.....	388
CSIM11:	Serial operation mode register 11.....	388

[D]

DMUC0:	Multiplier/divider control register 0.....	481
--------	--------------------------------------------	-----

[E]

EGN:	External interrupt falling edge enable register	497
EGP:	External interrupt rising edge enable register	497

[I]

IF0H:	Interrupt request flag register 0H.....	493
IF0L:	Interrupt request flag register 0L.....	493
IF1H:	Interrupt request flag register 1H.....	493
IF1L:	Interrupt request flag register 1L.....	493
IIC0:	IIC shift register 0.....	409
IICC0:	IIC control register 0.....	412
IICCL0:	IIC clock selection register 0.....	421
IICF0:	IIC flag register 0.....	419
IICS0:	IIC status register 0.....	417
IICX0:	IIC function expansion register 0.....	422
IMS:	Internal memory size switching register.....	558
ISC:	Input switch control register.....	362
IXS:	Internal expansion RAM size switching register.....	560

[K]

KRM:	Key return mode register.....	507
------	-------------------------------	-----

[L]

LVIM:	Low-voltage detection register.....	538
LVIS:	Low-voltage detection level selection register.....	539

[M]

MCM:	Main clock mode register.....	143
MDA0H:	Multiplication/division data register A0.....	479
MDA0L:	Multiplication/division data register A0.....	479
MDB0:	Multiplication/division data register B0.....	480
MK0H:	Interrupt mask flag register 0H.....	495
MK0L:	Interrupt mask flag register 0L.....	495
MK1H:	Interrupt mask flag register 1H.....	495
MK1L:	Interrupt mask flag register 1L.....	495
MOC:	Main OSC control register.....	142

[O]

OSCCTL:	Clock operation mode select register.....	137
OSTC:	Oscillation stabilization time counter status register.....	144, 509
OSTS:	Oscillation stabilization time select register.....	145, 510

[P]

P0:	Port register 0.....	127
P1:	Port register 1.....	127
P2:	Port register 2.....	127
P3:	Port register 3.....	127
P4:	Port register 4.....	127
P5:	Port register 5.....	127
P6:	Port register 6.....	127
P7:	Port register 7.....	127
P12:	Port register 12.....	127

P13:	Port register 13.....	127
P14:	Port register 14.....	127
PCC:	Processor clock control register.....	139
PM0:	Port mode register 0.....	125, 187, 392
PM1:	Port mode register 1.....	125, 252, 270, 334, 362, 392
PM2:	Port mode register 2.....	125, 314
PM3:	Port mode register 3.....	125, 252
PM4:	Port mode register 4.....	125
PM5:	Port mode register 5.....	125
PM6:	Port mode register 6.....	125, 424
PM7:	Port mode register 7.....	125
PM12:	Port mode register 12.....	125, 540
PM14:	Port mode register 14.....	125, 303
PR0H:	Priority specification flag register 0H.....	496
PR0L:	Priority specification flag register 0L.....	496
PR1H:	Priority specification flag register 1H.....	496
PR1L:	Priority specification flag register 1L.....	496
PRM00:	Prescaler mode register 00.....	184
PRM01:	Prescaler mode register 01.....	184
PU0:	Pull-up resistor option register 0.....	128
PU1:	Pull-up resistor option register 1.....	128
PU3:	Pull-up resistor option register 3.....	128
PU4:	Pull-up resistor option register 4.....	128
PU5:	Pull-up resistor option register 5.....	128
PU7:	Pull-up resistor option register 7.....	128
PU12:	Pull-up resistor option register 12.....	128
PU14:	Pull-up resistor option register 14.....	128
[R]		
RCM:	Internal oscillation mode register.....	141
RESF:	Reset control flag register.....	529
RXB0:	Receive buffer register 0.....	329
RXB6:	Receive buffer register 6.....	353
[S]		
SDR0:	Remainder data register 0.....	479
SIO10:	Serial I/O shift register 10.....	387
SIO11:	Serial I/O shift register 11.....	387
SOTB10:	Transmit buffer register 10.....	386
SOTB11:	Transmit buffer register 11.....	386
SVA0:	Slave address register 0.....	409
[T]		
TCL50:	Timer clock selection register 50.....	248
TCL51:	Timer clock selection register 51.....	248
TM00:	16-bit timer counter 00.....	172
TM01:	16-bit timer counter 01.....	172

TM50:	8-bit timer counter 50	247
TM51:	8-bit timer counter 51	247
TMC00:	16-bit timer mode control register 00.....	176
TMC01:	16-bit timer mode control register 01.....	176
TMC50:	8-bit timer mode control register 50.....	250
TMC51:	8-bit timer mode control register 51.....	250
TMCYC1:	8-bit timer H carrier control register 1	270
TMHMD0:	8-bit timer H mode register 0	266
TMHMD1:	8-bit timer H mode register 1	266
TOC00:	16-bit timer output control register 00.....	181
TOC01:	16-bit timer output control register 01.....	181
TXB6:	Transmit buffer register 6	353
TXS0:	Transmit shift register 0.....	329
[W]		
WDTE:	Watchdog timer enable register	295
WTM:	Watch timer operation mode register	289

APPENDIX D REVISION HISTORY

D.1 Major Revisions in This Edition

(1/7)

Page	Description
CHAPTER 1 OUTLINE	
pp. 17, 18	Addition of Note on a product with on-chip debug function to and modification of operating ambient temperature in 1.1 Features
p. 18	Addition of special grade products supporting automotive equipment to 1.2 Applications
p. 19	Modification of 1.3 Ordering Information
p. 23, 24	Addition of 64-pin plastic TQFP (7x7), 64-pin plastic FLGA (5x5), Note to and modification of Caution 1 in 1.4 Pin Configuration (Top View)
pp. 27, 28	Modification of the following items on the function list in 1.5 78K0/Kx2 Series Lineup <ul style="list-style-type: none"> • Supply voltage range of internal low-speed oscillation clock • Detection voltage of POC • Operating ambient temperature
p. 29	Addition of pin to “On-chip debug” in 1.6 Block Diagram
pp. 30, 31	Modification of the following items in 1.7 Outline of Functions <ul style="list-style-type: none"> • Oscillation frequency range of high-speed system clock • Supply voltage range of internal low-speed oscillation clock • Operating ambient temperature • Package
p. 31	Modification of outline of timer in 1.7 Outline of Functions
CHAPTER 2 PIN FUNCTIONS	
p. 32	Modification of Table 2-1 Pin I/O Buffer Power Supplies
pp. 32 to 35	Addition of Note to 2.1 Pin Function List
p. 41	Modification of descriptions in 2.2.12 AV_{REF}
p. 41	Addition of Caution to 2.2.15 REGC
p. 42	Modification of descriptions in 2.2.16 V_{DD} and EV_{DD} , and 2.2.17 V_{SS} and EV_{SS}
p. 44	Modification of recommended connection of unused pins of P121/X1, P122/X2/EXCLK, P123/XT1, and P124/XT2/EXCLKS in Table 2-2 Pin I/O Circuit Types
CHAPTER 3 CPU ARCHITECTURE	
p. 47	Addition of Caution 2 to 3.1 Memory Space
p. 47	Modification of Table 3-1 Set Values of Internal Memory Size Switching Register (IMS) and Internal Expansion RAM Size Switching Register (IXS)
pp. 48 to 55	Modification of Figure 3-1 Memory Map (μPD78F0531) to Figure 3-8 Memory Map (μPD78F0537D)
p. 57	Modification of description in (3) Option byte area and (5) On-chip debug security ID setting area (μPD78F0537D only) in 3.1.1
p. 58	Modification of description in 3.1.2 Memory bank (μPD78F0536, 78F0537, and 78F0537D only)
pp. 65, 66	Addition of Note to Figure 3-14 Correspondence Between Data Memory and Addressing (μPD78F0536) and Figure 3-15 Correspondence Between Data Memory and Addressing (μPD78F0537, 78F0537D)
p. 77	Addition to description in 3.3 Instruction Address Addressing
p. 78	Addition to description in 3.3.2 Immediate addressing
p. 79	Addition to description in 3.3.3 Table indirect addressing
p. 82	Addition to description in 3.4.3 Direct addressing
p. 83	Modification of [Description example] in 3.4.4 Short direct addressing

Page	Description
p. 85	Addition to description in 3.4.6 Register indirect addressing
p. 86	Addition to description in 3.4.7 Based addressing
p. 87	Addition to description in 3.4.8 Based indexed addressing
CHAPTER 4 MEMORY BANK SELECT FUNCTION (μPD78F0536, 78F0537, AND 78F0537D ONLY)	
p. 89	Addition of chapter
CHAPTER 5 PORT FUNCTIONS	
p. 99	Modification of Table 5-1 Pin I/O Buffer Power Supplies
p. 102	Addition of Caution to 5.2.1 Port 0
p. 102	Modification of Figure 5-2 Block Diagram of P00
p. 103	Modification of Figure 5-3 Block Diagram of P01
p. 104	Modification of Figure 5-4 Block Diagram of P02
p. 105	Modification of Figure 5-5 Block Diagram of P03, P05
p. 106	Modification of Figure 5-6 Block Diagram of P04
p. 107	Modification of Figure 5-7 Block Diagram of P06
p. 108	Addition of Caution to 5.2.2 Port 1
p. 113	Addition of description to 5.2.3 Port 2 and addition of Table 5-4 Setting Functions of P20/ANI0 to P27/ANI7 Pins
p. 121	Addition of Remark to and modification of Caution in 5.2.9 Port 12
p. 121	Modification of Figure 5-22 Block Diagram of P120
p. 122	Modification of Figure 5-23 Block Diagram of P121 to P124
p. 123	Addition of a figure to Remark in 5.2.10 Port 13
p. 129	Addition of (4) A/D port configuration register (ADPC) to 5.3 Registers Controlling Port Function
pp. 132, 133	Addition of Remark 2 and Notes 1 and 2 to Table 5-5 Settings of Port Mode Register and Output Latch When Using Alternate Function (2/2)
CHAPTER 6 CLOCK GENERATOR	
p. 134	Modification of oscillation frequency range X1 oscillator and external main system clock in 6.1 (1) Main system clock
p. 135	Addition to description in 6.1 (3) Internal low-speed oscillation clock
p. 136	Modification of Figure 6-1 Block Diagram of Clock Generator
p. 139	Modification of Figure 6-3 Format of Processor Clock Control Register (PCC)
p. 140	Addition of 6.3 (3) Setting of operation mode for subsystem clock pin
p. 145	Modification of description in 6.3 (8) Oscillation stabilization time select register (OSTS)
p. 146	Modification of oscillation frequency range in 6.4.1 X1 oscillator
p. 149	Modification of description in 6.4.3 When subsystem clock is not used
p. 151	Addition of Figure 6-12 Clock Generator Operation When Power Supply Voltage Is Turned On (When 1.59 V POC Mode Is Set (Option Byte: POCMODE = 0))
p. 152	Addition of Figure 6-13 Clock Generator Operation When Power Supply Voltage Is Turned On (When 2.7 V/1.59 V POC Mode Is Set (Option Byte: POCMODE = 1))
p. 153	Modification of 6.6.1 Controlling high-speed system clock
p. 156	Modification of 6.6.2 Example of controlling internal high-speed oscillation clock
p. 158	Modification of 6.6.3 Example of controlling subsystem clock
p. 160	Modification of description in Table 6-4 Clocks Supplied to CPU and Peripheral Hardware, and Register Setting

Page	Description
p. 161	Addition of Remark to Figure 6-14 CPU Clock Status Transition Diagram (When 1.59 V POC Mode Is Set (Option Byte: POCMODE = 0))
pp. 162 to 165	Modification of the following items in Table 6-5 CPU Clock Transition and SFR Register Setting Examples (3) CPU operating with subsystem clock (D) after reset release (A) (4) CPU clock changing from internal high-speed oscillation clock (B) to high-speed system clock (C) (5) CPU clock changing from internal high-speed oscillation clock (B) to subsystem clock (D) (7) CPU clock changing from high-speed system clock (C) to subsystem clock (D) (9) CPU clock changing from subsystem clock (D) to high-speed system clock (C)
p. 166	Modification of Table 6-6 Changing CPU Clock
p. 167	Addition of 6.6.8 Time required for switchover of CPU clock and main system clock
p. 168	Addition of 6.6.9 Conditions before clock oscillation is stopped
p. 169	Addition of 6.6.10 Peripheral Hardware and Source Clocks
CHAPTER 7 16-BIT TIMER/EVENT COUNTERS 00 AND 01	
p. 170	Revision of chapter
CHAPTER 8 8-BIT TIMER/EVENT COUNTERS 50 AND 51	
p. 247	Modification of description in 8.2 (2) 8-bit timer compare register 5n (CR5n)
CHAPTER 9 8-BIT TIMERS H0 AND H1	
p. 264	Modification of Figure 9-2 Block Diagram of 8-Bit Timer H1
p. 265	Modification of description in (1) 8-bit timer H compare register 0n (CMP0n) and (2) 8-bit timer H compare register 1n (CMP1n) in 9.2
p. 269	Modification of Figure 9-6 Format of 8-Bit Timer H Mode Register 1 (TMHMD1)
p. 279	Modification of Figure 9-12 (e) Operation by changing CMP1n (CMP1n = 02H → 03H, CMP0n = A5H)
p. 280	Modification of description in 9.4.3 Carrier generator operation (8-bit timer H1 only)
p. 281	Addition of <3> to Figure 9-13 Transfer Timing
p. 282	Addition of <8> to Setting in 9.4.3
pp. 284, 285	Modification of (a) Operation when CMP01 = N, CMP11 = N and (b) Operation when CMP01 = N, CMP11 = M in Figure 9-15
p. 286	Modification of description in Figure 9-15 (c) Operation when CMP11 is changed
CHAPTER 11 WATCHDOG TIMER	
p. 293	Modification of description in 11.1 Functions of Watchdog Timer
pp. 296, 297	Addition to description in and addition of Caution 4 to 11.4.1 Controlling operation of watchdog timer
CHAPTER 12 CLOCK OUTPUT/BUZZER OUTPUT CONTROLLER	
p. 302	Addition of Note 1 and Cautions 1 and 2 to Figure 12-2 Format of Clock Output Selection Register (CKS)
CHAPTER 13 A/D CONVERTER	
pp. 305, 306	Modification of the following items in 13.2 Configuration of A/D Converter (2) Sample & hold circuit (3) Series resistor string (5) Successive approximation register (SAR) (9) AV_{REF} pin
p. 309	Addition to Caution 1 in and addition of Caution 4 to Table 13-2 A/D Conversion Time Selection
p. 312	Modification of Cautions 2 and 3 in Figure 13-8 Format of Analog Input Channel Specification Register (ADS)
p. 313	Modification of description in 13.3 (5) A/D port configuration register (ADPC)
p. 313	Modification of Cautions 1 and 2 in Figure 13-9 Format of A/D Port Configuration Register (ADPC)

Page	Description
p. 314	Modification of Table 13-3 Setting Functions of ANI0/P20 to ANI7/P27 Pins
p. 315	Modification of 13.4.1 Basic operations of A/D converter
p. 316	Modification of description in Figure 13-11 Basic Operation of A/D Converter
p. 317	Modification of expression in 13.4.2 Input voltage and conversion results
pp. 318, 319	Modification of description in 13.4.3 A/D converter operation mode
pp. 322, 323, 325	Modification of the description of the following items in 13.6 Cautions for A/D Converter (1) Operating current in STOP mode (4) Noise countermeasures (6) Input impedance of ANI0 to ANI7 pins (11) Internal equivalent circuit
CHAPTER 14 SERIAL INTERFACE UART0	
p. 326	Addition of maximum transfer rate and Caution 4 to 14.1 (2) Asynchronous serial interface (UART) mode
p. 329	Addition of Caution 1 to 14.2 (3) Transmit shift register 0 (TXS0)
p. 331	Addition of Caution 5 to Figure 14-2 Format of Asynchronous Serial Interface Operation Mode Register 0 (ASIM0)
p. 332	Modification of description in 14.3 (2) Asynchronous serial interface reception error status register 0 (ASIS0)
p. 340	Modification of Caution 1 in Figure 14-9 Reception Completion Interrupt Request Timing
p. 343	Addition of Table 14-4 Set Value of TPS01 and TPS00
CHAPTER 15 SERIAL INTERFACE UART6	
p. 347	Addition of maximum transfer rate and Cautions 4 and 5 to 15.1 (2) Asynchronous serial interface (UART) mode
p. 348	Modification of Figure 15-1 LIN Transmission Operation
p. 349	Modification of Figure 15-2 LIN Reception Operation
p. 353	Addition of Caution 3 to 15.2 (3) Transmit buffer register 6 (TXB6)
p. 355	Addition of Cautions 4 and 5 to Figure 15-5 Format of Asynchronous Serial Interface Operation Mode Register 6 (ASIM6)
p. 356	Modification of description in 15.3 (2) Asynchronous serial interface reception error status register 6 (ASIS6)
p. 361	Addition of Caution 6 to Figure 15-10 Format of Asynchronous Serial Interface Control Register 6 (ASICL6)
p. 362	Modification of description in 15.3 (7) Input switch control register (ISC)
p. 373	Modification of Caution 1 in 15.4.2 (2) (e) Normal reception
CHAPTER 16 SERIAL INTERFACE CSI10, CSI11	
p. 385	Modification of Figure 16-1 Block Diagram of Serial Interface CSI10
p. 386	Modification of Figure 16-2 Block Diagram of Serial Interface CSI11
p. 386	Modification of Caution 2 in 16.2 (1) Transmit buffer register 1n (SOTB1n)
p. 387	Modification of Caution 2 in 16.2 (2) Serial I/O shift register 1n (SIO1n)
p. 388	Modification of Note 2 in Figure 16-3 Format of Serial Operation Mode Register 10 (CSIM10)
p. 389	Modification of Note 2 in Figure 16-4 Format of Serial Operation Mode Register 11 (CSIM11)
p. 390	Modification of Caution 2 in Figure 16-5 Format of Serial Clock Selection Register 10 (CSIC10)
p. 391	Modification of Caution 2 in Figure 16-6 Format of Serial Clock Selection Register 11 (CSIC11)
p. 393	Modification of Note 1 of CSIM10 and CSIM11 in 16.4.1 (1) Register used

Page	Description
pp. 401, 402	Addition of (b) Type 3: CKP1n = 1, DAP1n = 0 and (d) Type 4: CKP1n = 1, DAP1n = 1 to Figure 16-11 Output Operation of First Bit
pp. 403, 404	Addition of (b) Type 3: CKP1n = 1, DAP1n = 0 and (d) Type 4: CKP1n = 1, DAP1n = 1 in Figure 16-12 Output Value of SO1n Pin (Last Bit)
CHAPTER 17 SERIAL INTERFACE IIC0	
p. 407	Modification of Figure 17-1 Block Diagram of Serial Interface IIC0
p. 409	Addition of Caution 2 to 17.2 (1) IIC shift register 0 (IIC0) and addition to description in (2) Slave address register 0 (SVA0)
p. 410	Addition of 17.2 (13) Stop condition generator
p. 413	Addition of description to IICE0 and addition of Caution to Figure 17-5 Format of IIC Control Register 0 (IICC0) (1/4)
p. 414	Addition of Note 2 to Figure 17-5 Format of IIC Control Register 0 (IICC0) (2/4)
p. 415	Addition of description to STT0 in Figure 17-5 Format of IIC Control Register 0 (IICC0) (3/4)
p. 420	Addition of clearing condition to STCF and IICBSY in Figure 17-7 Format of IIC Flag Register 0 (IICF0)
p. 421	Modification of description in 17.3 (4) IIC clock selection register 0 (IICCL0)
pp. 422, 423	Modification of description in 17.3 (6) I²C transfer clock setting method
p. 423	Modification of Table 17-2 Selection Clock Setting
p. 428	Addition of cause that \overline{ACK} is not returned to 17.5.4 Acknowledge (\overline{ACK})
p. 432	Addition of 17.5.7 Canceling wait
p. 437	Modification of Table 17-6 Wait Periods and Figure 17-20 Communication Reservation Timing
p. 440	Modification of Table 17-7 Wait Periods
pp. 440, 441	Addition of (4) to (6) to 17.5.15 Other cautions
pp. 442, 443	Modification of 17.5.16 (1) Master operation (single-master system) and (2) Master operation (multi-master system)
pp. 447, 448	Modification of Figure 17-25 Slave Operation Flowchart (1) and Figure 17-26 Slave Operation Flowchart (2)
p. 450	Addition of Note to (a) (i) When WTIM0 = 0 to and modification of (ii) When WTIM0 = 1 in 17.5.17 (1) Master device operation
p. 451	Addition of Notes 1 to 3 to (b) (i) When WTIM0 = 0 in 17.5.17 (1) Master device operation
p. 452	Addition of Note to (c) (i) When WTIM0 = 0 in 17.5.17 (1) Master device operation
pp. 456, 460, 466, 469	Modification of the value of the following items of IICS0 register in 17.5.17 (2) (d) (i) When WTIM0 = 0 (after restart, does not match with address (= not extension code)) (2) (d) (ii) When WTIM0 = 1 (after restart, does not match with address (= not extension code)) (3) (d) (i) When WTIM0 = 0 (after restart, does not match with address (= not extension code)) (3) (d) (ii) When WTIM0 = 1 (after restart, does not match with address (= not extension code)) (6) (d) (ii) Extension code (6) (e) When loss occurs due to stop condition during data transfer (6) (h) (ii) When WTIM0 = 1
pp. 461, 463	Addition of description to 17.5.17 (5) Arbitration loss operation (operation as slave after arbitration loss) and (6) Operation when arbitration loss occurs (no communication after arbitration loss)

Page	Description
pp. 467 to 469	Addition of description when (i) When WTIM0 = 0 to the following items in 17.5.17 (6) Operation when arbitration loss occurs (no communication after arbitration loss) (f) When arbitration loss occurs due to low-level data when attempting to generate a restart condition (g) When arbitration loss occurs due to a stop condition when attempting to generate a restart condition (h) When arbitration loss occurs due to low-level data when attempting to generate a stop condition
pp. 471 to 476	Modification of Figure 17-27 Example of Master to Slave Communication (When 9-Clock Wait Is Selected for Both Master and Slave) and Figure 17-28 Example of Slave to Master Communication (When 8-Clock Wait Is Selected for Master, 9-Clock Wait Is Selected for Slave)
CHAPTER 18 MULTIPLIER/DIVIDER (μPD78F0534, 78F0535, 78F0536, 78F0537, AND 78F0537D ONLY)	
p. 485	Modification of Figure 18-7. Timing Chart of Division Operation (DCBA2586H + 0018H)
CHAPTER 21 STANDBY FUNCTION	
p. 508	Modification of Caution 3 in 21.1.1 Standby function
p. 510	Modification of description in 21.1.2 (2) Oscillation stabilization time select register (OSTS)
pp. 512, 513	Addition of clock output and buzzer output to items in and addition of Note to Table 21-1 Operating Statuses in HALT Mode
p. 515	Modification of Figure 21-4 HALT Mode Release by Reset
p. 517	Addition of clock output and buzzer output to items in and addition of Note to Table 21-3 Operating Statuses in STOP Mode
p. 518	Modification of Figure 21-5 Operation Timing When STOP Mode Is Released
p. 520	Modification of Figure 21-7 STOP Mode Release by Reset
CHAPTER 22 RESET FUNCTION	
p. 523	Modification of Figure 22-2 Timing of Reset by $\overline{\text{RESET}}$ Input
p. 523	Modification of Figure 22-3 Timing of Reset Due to Watchdog Timer Overflow
p. 524	Modification of Figure 22-4 Timing of Reset in STOP Mode by $\overline{\text{RESET}}$ Input
p. 525	Addition of clock output and buzzer output to items in Table 22-1 Operation Statuses During Reset Period
p. 528	Modification of table in Note of Table 22-2 Hardware Statuses After Reset Acknowledgment (3/3)
CHAPTER 23 POWER-ON-CLEAR CIRCUIT	
p. 530	Addition of description of 2.7 V/1.59 V POC mode to 23.1 Functions of Power-on-Clear Circuit
p. 531	Modification of 23.3 Operation of Power-on-Clear Circuit
p. 534	Modification of Figure 23-3 Example of Software Processing After Reset Release (1/2)
CHAPTER 24 LOW-VOLTAGE DETECTOR	
p. 536	Modification of Figure 24-1 Block Diagram of Low-Voltage Detector
p. 539	Modification of Figure 24-3 Format of Low-Voltage Detection Level Selection Register (LVIS)
p. 543	Addition of (2) In 2.7 V/1.59 V POC mode (option byte: POCMODE = 1) to Figure 24-5 Timing of Low-Voltage Detector Internal Reset Signal Generation (Detects Level of Supply Voltage (V_{DD}))
pp. 547, 548	Modification of (1) In 1.59 V POC mode (option byte: POCMODE = 0) in and addition of (2) In 2.7 V/1.59 V POC mode (option byte: POCMODE = 1) to Figure 24-7 Timing of Low-Voltage Detector Interrupt Signal Generation (Detects Level of Supply Voltage (V_{DD}))
p. 550	Modification of Figure 24-8 Timing of Low-Voltage Detector Interrupt Signal Generation (Detects Level of Input Voltage from External Input Pin (EXLVI))
p. 552	Modification of Figure 24-9 Example of Software Processing After Reset Release (1/2)

Page	Description
CHAPTER 25 OPTION BYTE	
p. 554	Modification of description in 25.1 Functions of Option Bytes
pp. 555, 556	Modification of Note in and addition of setting of area 0081H/1081H to 0084H/1084H to Figure 25-1 Format of Option Byte
p. 557	Modification of description example of software for setting the option bytes
CHAPTER 26 FLASH MEMORY	
p. 558	Addition of Caution to Figure 26-1 Format of Internal Memory Size Switching Register (IMS)
p. 560	Addition of Caution to Figure 26-2 Format of Internal Expansion RAM Size Switching Register (IXS)
p. 562	Modification of value of V_{DD} in Figure 26-3 Example of Wiring Adapter for Flash Memory Writing in 3-Wire Serial I/O (CSI10) Mode
p. 563	Modification of value of V_{DD} in Figure 26-4 Example of Wiring Adapter for Flash Memory Writing in UART (UART6) Mode
pp. 564, 565	Modification of transfer rate in (1) CSI10 and (2) UART6 in 26.5
p. 570	Modification of transfer rate in Speed column of Table 26-7 Communication Modes
p. 572	Addition of 26.8 Security Settings
p. 576	Modification of 26.9.1 Boot swap function
p. 577	Modification of Figure 26-18 Boot Swap Function
CHAPTER 27 ON-CHIP DEBUG FUNCTION (μPD78F0537D ONLY)	
p. 578	Revision of chapter
CHAPTER 29 ELECTRICAL SPECIFICATIONS (TARGET)	
p. 593	Revision of chapter
CHAPTER 30 PACKAGE DRAWINGS	
pp. 612 to 616	Addition of package drawing
CHAPTER 31 CAUTIONS FOR WAIT	
p. 618	Modification of <Conditions for maximum/minimum number of wait clocks> of A/D converter in Table 31-1 Registers That Generate Wait and Number of CPU Wait Clocks
APPENDIX A DEVELOPMENT TOOLS	
p. 621	Addition of (2) When using the on-chip debug emulator QB-78K0MINI to Figure A-1 Development Tool Configuration
p. 625	Addition of A.5.2 When using on-chip debug emulator QB-78K0MINI
APPENDIX B NOTES ON TARGET SYSTEM DESIGN	
p. 626	Addition of chapter
APPENDIX D REVISION HISTORY	
p. 636	Addition of chapter

★ **D.2 Revision History up to Previous Edition**

Revisions up to the previous edition are shown below. The “Applied to:” column indicates the chapter in each edition to which the revision was applied.

(1/2)

Edition	Description	Applied to
2nd edition	Addition of only μ PD78F0537D as on-chip debug function model	Throughout
	Addition of Caution 3 to 1.4 Pin Configuration (Top View)	CHAPTER 1 OUTLINE
	Addition of description of EXSCL0 to (2) Non-port pins in 2.1 Pin Function List	CHAPTER 2 PIN FUNCTIONS
	Addition of Caution to (2) Control mode in 2.2.3 P20 to P27 (port 2)	
	Addition of description to (c) EXSCL0 of (2) Control mode in 2.2.7 P60 to P63 (port 6)	
	Addition of Note 2 to Table 2-2 Pin I/O Circuit Types	
	Addition of Cautions 1, 2, and 3 to 3.1.2 Bank area (μPD78F0536, 78F0537, and 78F0537D only)	CHAPTER 3 CPU ARCHITECTURE
	Deletion of descriptions of the FLPMD, PFCMD, and PFS registers	
	Addition of Remark to 4.2.7 Port 6	CHAPTER 4 PORT FUNCTIONS
	Modification of output latch setting of P60 and P61 in Table 4-4 Settings of Port Mode Register and Output Latch When Using Alternate Function	
	Addition of Cautions 2 and 3 to Figure 5-6 Format of Clock Operation Mode Select Register (OSCCTL)	CHAPTER 5 CLOCK GENERATOR
	6.4.6 One-shot pulse output operation	CHAPTER 6 16-BIT TIMER/EVENT COUNTERS 00 AND 01
	<ul style="list-style-type: none"> Modification of Caution 1 in (1) One-shot pulse output with software trigger Modification of Caution in (2) One-shot pulse output with external trigger 	
	Modification of (a) One-shot pulse output by software and (b) One-shot pulse output with external trigger of (5) Re-triggering one-shot pulse in 6.5 Cautions for 16-Bit Timer/Event Counters 00 and 01	CHAPTER 14 SERIAL INTERFACE UART6
	Modification of Caution in (6) Asynchronous serial interface control register 6 (ASICL6) of 14.3 Registers Controlling Serial Interface UART6	
	Modification of Cautions 1, 2, and 4 in Figure 14-10 Format of Asynchronous Serial Interface Control Register 6 (ASICL6)	
	Modification of description in (7) Port mode register 6 (PM6) of 16.3 Registers to Control Serial Interface IIC0	CHAPTER 16 SERIAL INTERFACE IIC0
	Addition of “WRELO = WTIM0 = 1” to “ACKE0 = 0” in Figure 16-23 Master Operation Flowchart (1) and Figure 16-24 Master Operation Flowchart (2)	
	Modification of 20.2.1 HALT mode	CHAPTER 20 STANDBY FUNCTION
	Addition of Caution 4 to Table 20-3 Operating Statuses in STOP Mode	
Addition of Note to Figure 22-2 Timing of Internal Reset Signal Generation in Power-on-Clear Circuit	CHAPTER 22 POWER-ON-CLEAR CIRCUIT	
Change of value of operation stabilization time in CHAPTER 23 LOW-VOLTAGE DETECTOR to 10 μ s (TYP.) and addition of Note “This value may change after evaluation.”	CHAPTER 23 LOW-VOLTAGE DETECTOR	
Modification of transfer rate in 25.6 (2) UART6	CHAPTER 25 FLASH MEMORY	
Modification of transfer rate and deletion of Notes 2 in Speed column of UART in Table 25-7. Communication Modes		
Modification of description in 25.9 Flash Memory Programming by Self-Writing		

(2/2)

Edition	Description	Applied to
2nd edition	Total revision of CHAPTER 26 ON-CHIP DEBUG FUNCTION (μPD78F0537D ONLY)	CHAPTER 26 ON-CHIP DEBUG FUNCTION (μ PD78F0537D ONLY)
	Total revision of CHAPTER 28 ELECTRICAL SPECIFICATIONS (TARGET)	CHAPTER 28 ELECTRICAL SPECIFICATIONS (TARGET)
	Total revision of APPENDIX A DEVELOPMENT TOOLS	APPENDIX A DEVELOPMENT TOOLS