



POWER-MOS FET

FIELD EFFECT POWER TRANSISTOR

IRF720,721
D84CQ2,Q1

3 AMPERES
400, 350 VOLTS
RDS(ON) = 1.8 Ω

This series of N-Channel Enhancement-mode Power MOSFETs utilizes GE's advanced Power DMOS technology to achieve low on-resistance with excellent device ruggedness and reliability.

This design has been optimized to give superior performance in most switching applications including: switching power supplies, inverters, converters and solenoid/relay drivers. Also, the extended safe operating area with good linear transfer characteristics makes it well suited for many linear applications such as audio amplifiers and servo motors.

Features

- Polysilicon gate — Improved stability and reliability
- No secondary breakdown — Excellent ruggedness
- Ultra-fast switching — Independent of temperature
- Voltage controlled — High transconductance
- Low input capacitance — Reduced drive requirement
- Excellent thermal stability — Ease of paralleling

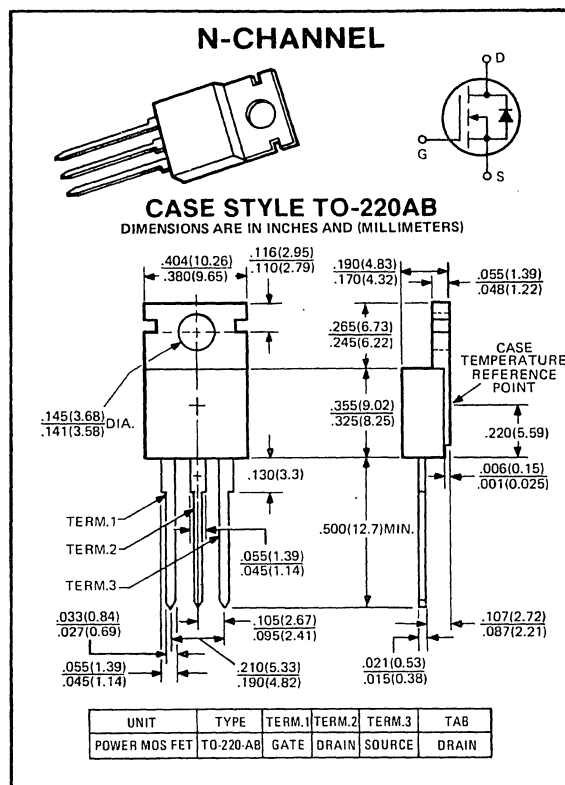

maximum ratings ($T_C = 25^\circ\text{C}$) (unless otherwise specified)

RATING	SYMBOL	IRF720/D84CQ2	IRF721/D84CQ1	UNITS
Drain-Source Voltage	V_{DSS}	400	350	Volts
Drain-Gate Voltage, $R_{GS} = 1M\Omega$	V_{DGR}	400	350	Volts
Continuous Drain Current @ $T_C = 25^\circ\text{C}$ @ $T_C = 100^\circ\text{C}$	I_D	3 2	3 2	A A
Pulsed Drain Current ⁽¹⁾	I_{DM}	12	12	A
Gate-Source Voltage	V_{GS}	± 20	± 20	Volts
Total Power Dissipation @ $T_C = 25^\circ\text{C}$ Derate Above 25°C	P_D	40 0.32	40 0.32	Watts W/ $^\circ\text{C}$
Operating and Storage Junction Temperature Range	T_J, T_{STG}	-55 to 150	-55 to 150	$^\circ\text{C}$

thermal characteristics

Thermal Resistance, Junction to Case	$R_{\theta JC}$	3.12	3.12	$^\circ\text{C}/\text{W}$
Thermal Resistance, Junction to Ambient	$R_{\theta JA}$	80	80	$^\circ\text{C}/\text{W}$
Maximum Lead Temperature for Soldering Purposes: $\frac{1}{8}$ " from Case for 5 Seconds	T_L	260	260	$^\circ\text{C}$

(1) Repetitive Rating: Pulse width limited by max. junction temperature.

electrical characteristics ($T_C = 25^\circ\text{C}$) (unless otherwise specified)

CHARACTERISTIC	SYMBOL	MIN	TYP	MAX	UNIT
----------------	--------	-----	-----	-----	------

off characteristics

Drain-Source Breakdown Voltage ($V_{GS} = 0V, I_D = 250\ \mu A$)	IRF720/D84CQ2 IRF721/D84CQ1	BV_{DSS}	400 350	— —	— —	Volts
Zero Gate Voltage Drain Current ($V_{DS} = \text{Max Rating}, V_{GS} = 0V, T_C = 25^\circ\text{C}$) ($V_{DS} = \text{Max Rating}, \times 0.8, V_{GS} = 0V, T_C = 125^\circ\text{C}$)		I_{DSS}	— —	— —	250 1000	μA
Gate-Source Leakage Current ($V_{GS} = \pm 20V$)		I_{GSS}	—	—	± 500	nA

on characteristics*

Gate Threshold Voltage ($V_{DS} = V_{GS}, I_D = 250\ \mu A$)	$T_C = 25^\circ\text{C}$	$V_{GS(TH)}$	2.0	—	4.0	Volts
On-State Drain Current ($V_{GS} = 10V, V_{DS} = 10V$)		$I_{D(ON)}$	3.0	—	—	A
Static Drain-Source On-State Resistance ($V_{GS} = 10V, I_D = 1.5A$)		$R_{DS(ON)}$	—	1.4	1.8	Ohms
Forward Transconductance ($V_{DS} = 10V, I_D = 1.5A$)		g_{fs}	0.9	1.6	—	mhos

dynamic characteristics

Input Capacitance	$V_{GS} = 10V$	C_{iss}	—	385	600	pF
Output Capacitance	$V_{DS} = 25V$	C_{oss}	—	70	200	pF
Reverse Transfer Capacitance	$f = 1\ \text{MHz}$	C_{rss}	—	12	40	pF

switching characteristics*

Turn-on Delay Time	$V_{DS} = 175V$ $I_D = 1.5A, V_{GS} = 15V$ $R_{GEN} = 50\ \Omega, R_{GS} = 12.5\ \Omega$ ($R_{GS}\ \text{(EQUIV.)} = 10\ \Omega$)	$t_{d(on)}$	—	15	—	ns
Rise Time		t_r	—	10	—	ns
Turn-off Delay Time		$t_{d(off)}$	—	25	—	ns
Fall Time		t_f	—	15	—	ns

source-drain diode ratings and characteristics*

Continuous Source Current	I_S	—	—	3	A
Pulsed Source Current	I_{SM}	—	—	12	A
Diode Forward Voltage ($T_C = 25^\circ\text{C}, V_{GS} = 0V, I_S = 3A$)	V_{SD}	—	1.0	1.6	Volts
Reverse Recovery Time ($I_S = 3A, di_S/dt = 100A/\mu\text{sec}, T_C = 125^\circ\text{C}$)	t_{rr} Q_{RR}	—	280 2.0	—	ns μC

*Pulse Test: Pulse width $\leq 300\ \mu s$, duty cycle $\leq 2\%$

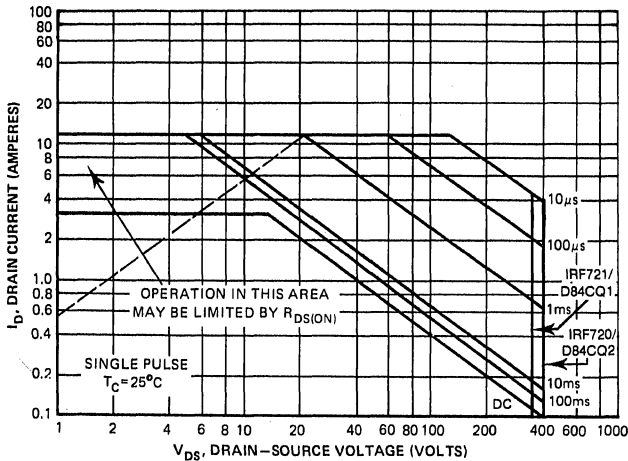

MAXIMUM SAFE OPERATING AREA

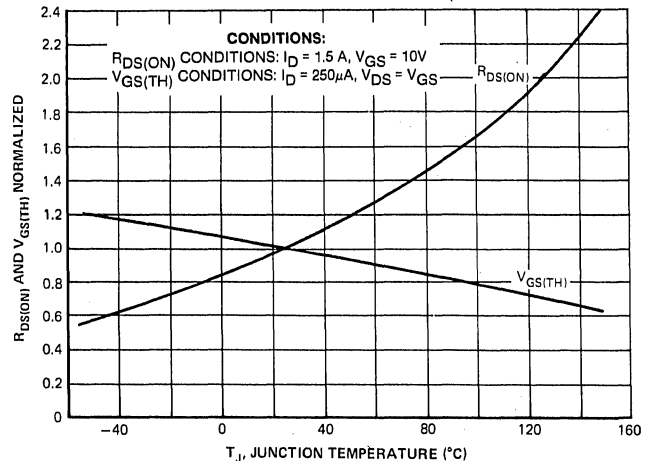

TYPICAL NORMALIZED $R_{DS(ON)}$ AND $V_{GS(TH)}$ VS. TEMP.