

isc Silicon NPN Power Transistor

2SD857

DESCRIPTION

- Collector-Emitter Breakdown Voltage-  
:  $V_{(BR)CEO} = 60V(\text{Min})$
- Good Linearity of  $h_{FE}$
- Wide Area of Safe Operation
- Complement to Type 2SB762

APPLICATIONS

- Designed for power amplifier applications.

ABSOLUTE MAXIMUM RATINGS( $T_a=25^{\circ}C$ )

SYMBOL	PARAMETER	VALUE	UNIT
$V_{CBO}$	Collector-Base Voltage	60	V
$V_{CEO}$	Collector-Emitter Voltage	60	V
$V_{EBO}$	Emitter-Base Voltage	5	V
$I_C$	Collector Current-Continuous	4	A
$I_{CM}$	Collector Current-Peak	8	A
$P_C$	Collector Power Dissipation @ $T_C=25^{\circ}C$	40	W
$T_J$	Junction Temperature	150	$^{\circ}C$
$T_{stg}$	Storage Temperature Range	-55~150	$^{\circ}C$

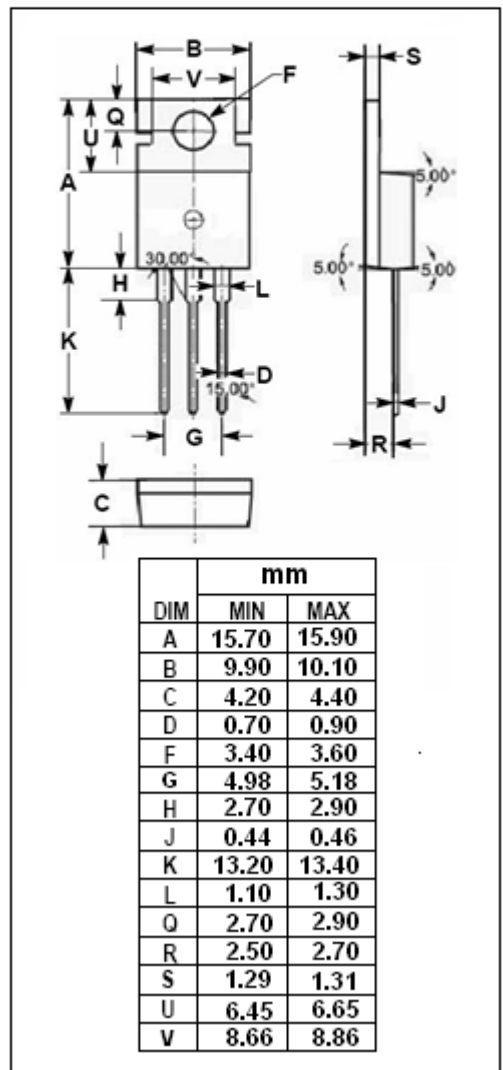
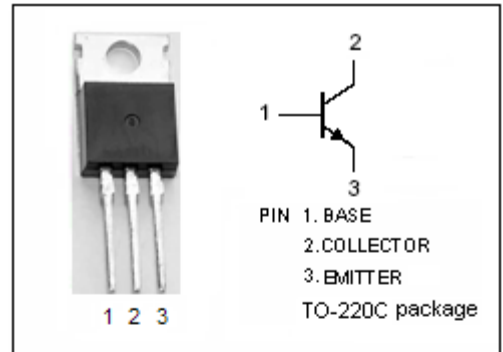

**isc Silicon NPN Power Transistor****2SD857****ELECTRICAL CHARACTERISTICS** $T_C=25^{\circ}\text{C}$  unless otherwise specified

SYMBOL	PARAMETER	CONDITIONS	MIN	TYP.	MAX	UNIT
$V_{(BR)CEO}$	Collector-Emitter Breakdown Voltage	$I_C=30\text{mA}; I_B=0$	60			V
$V_{CE(sat)}$	Collector-Emitter Saturation Voltage	$I_C=4\text{A}; I_B=0.4\text{A}$			1.5	V
$V_{BE(on)}$	Base-Emitter On Voltage	$I_C=3\text{A}; V_{CE}=4\text{V}$			2.0	V
$I_{CEO}$	Collector Cutoff Current	$V_{CE}=30\text{V}; I_B=0$			700	$\mu\text{A}$
$I_{CES}$	Collector Cutoff Current	$V_{CE}=60\text{V}; V_{BE}=0$			400	$\mu\text{A}$
$I_{EBO}$	Emitter Cutoff Current	$V_{EB}=5\text{V}; I_C=0$			1	mA
$h_{FE-1}$	DC Current Gain	$I_C=1\text{A}; V_{CE}=4\text{V}$	40		250	
$h_{FE-2}$	DC Current Gain	$I_C=3\text{A}; V_{CE}=4\text{V}$	15			

## Switching Times

$t_{on}$	Turn-On Time	$I_C=4\text{A}; I_{B1}=-I_{B2}=0.4\text{A}$		0.2		$\mu\text{s}$
$t_{off}$	Turn-Off Time			1.4		$\mu\text{s}$

◆  $h_{FE-1}$  Classifications

R	Q	P
40-90	70-150	120-250