



2SD862

Silicon Epitaxial Planar Transistor

GENERAL DESCRIPTION

Silicon NPN high frequency, Low $V_{ce(sat)}$ middle power transistors in a plastic envelope, primarily for use in audio and general purpose



TO-126

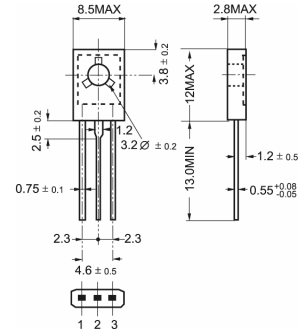

QUICK REFERENCE DATA

SYMBOL	PARAMETER	CONDITIONS	TYP	MAX	UNIT
V_{CESM}	Collector-emitter voltage peak value	$V_{BE} = 0V$	-	20	V
V_{CEO}	Collector-emitter voltage (open base)		-	20	V
I_C	Collector current (DC)		-	2	A
I_{CM}	Collector current peak value		-		A
P_{tot}	Total power dissipation	$T_{mb} \leq 25^\circ C$	-	10	W
V_{CEsat}	Collector-emitter saturation voltage	$I_C = 1.5A; I_B = 0.15A$	-	0.5	V
V_F	Diode forward voltage	$I_F = 1.5A$	1.5	2.0	V
t_f	Fall time			-	μS

LIMITING VALUES

SYMBOL	PARAMETER	CONDITIONS	MIN	MAX	UNIT
V_{CESM}	Collector-emitter voltage peak value	$V_{BE} = 0V$	-	20	V
V_{CEO}	Collector-emitter voltage (open base)		-	20	V
V_{EBO}	Emitter-base voltage (open collector)			6	V
I_C	Collector current (DC)		-	2	A
I_B	Base current (DC)		-	0.5	A
P_{tot}	Total power dissipation	$T_{mb} \leq 25^\circ C$	-	10	W
T_{sta}	Storage temperature		-55	150	$^\circ C$
T_j	Junction temperature		-	150	$^\circ C$

ELECTRICAL CHARACTERISTICS

SYMBOL	PARAMETER	CONDITIONS	TYP	MAX	UNIT
I_{CBO}	Collector-base cut-off current	$V_{CB} = 20V$	-	0.1	mA
I_{EBO}	Emitter-base cut-off current	$V_{EB} = 5V$	-	0.2	mA
$V_{(BR)CEO}$	Collector-emitter breakdown voltage	$I_C = 1mA$	20		V
V_{CEsat}	Collector-emitter saturation voltages	$I_C = 1.5A; I_B = 0.15A$	-	0.5	V
h_{FE}	DC current gain	$I_C = 100mA; V_{CE} = 2V$	60	400	
f_T	Transition frequency at $f = 5MHz$	$I_C = 0.5A; V_{CE} = 12V$	80	-	MHz
C_c	Collector capacitance at $f = 1MHz$	$V_{CB} = 10V$	75	-	pF
t_{on}	On times				μs
t_s	Turn-off storage time				μs
t_f	Fall time				μs